

Copyright is owned by the Author of the thesis. Permission is given for a copy to be downloaded by an individual for the purpose of research and private study only. The thesis may not be reproduced elsewhere without the permission of the Author.

MODALITY EFFECTS AND THE RELATIONAL DIMENSION
IN THE ABSTRACTION OF MEMORY SCHEMA

A thesis presented in partial fulfilment of the
requirements for the Degree of Master of Arts
in Psychology at Massey University.

Margaret Shannon Roache

1976

ACKNOWLEDGEMENTS

I would like to thank my supervisor, Mr. Kerry Chamberlain for the encouragement, advice and generous allocation of his time given throughout this research. I would also like to thank Dr. Elisabeth Wells for her assistance with the statistical power analysis, and Professor George Shouksmith for the freedom he extended in the choice of topic.

To the children and teachers of Standard 3 and 4 classes at Roslyn School, Palmerston North, whose co-operation made this research possible, special thanks are due.

TABLE OF CONTENTS

	<u>Page</u>
ACKNOWLEDGEMENTS	ii.
ABSTRACT	vii.
INTRODUCTION	1.
LITERATURE REVIEW	4.
The Bransford and Frank's Approach: The Original Experiments and Related Studies.	4.
Replications and Critiques: The Role of Instructions.	6.
The Integration of Extra-Linguistic Inferences.	12.
The Organization of Stimulus Information.	15.
The Relational Aspects of Sentence Comprehension and Memory.	18.
Schema Formation: Abstraction from Visual and Pictorial Materials.	23.
THE PRESENT STUDY	32.
METHOD	35.
RESULTS	40.
DISCUSSION	47.
REFERENCES	57.
APPENDICES	64.

LIST OF TABLES

	<u>Page</u>
TABLE 1	
Means and Standard Deviations for Age and IQ Score for Four Groups of Subjects Assigned to Each Form of the Test.	38.
TABLE 2	
Percentage of Total Recognition Responses Given to Each of Four Types of Recognition Item.	40.
TABLE 3	
Percentage of Total Recognition Responses Given to Each of Four Types of Recognition Item for Specific Combinations of Modality and Relational Term.	41.
TABLE 4	
Proportional Analysis of Conditional Probabilities for Confidence Judgments.	45.
TABLE 5	
Cumulated Proportions of Confidence Judgments Cut Off at Five Confidence Levels.	45.

LIST OF FIGURES

	<u>Page</u>
FIGURE 1	
The Interaction Between Modality and Relational Term for A and B Recognition Items.	43.
FIGURE 2	
Representation of the Interaction Modality X Relational Term X Recognition Test for A and B Recognition Items.	43.

APPENDICES

	<u>Page</u>
APPENDIX A	64.
Materials	.
APPENDIX B	77.
Power Analysis for Estimation of Sample Size.	.
APPENDIX C	78.
Frequencies for Recognition Responses Given to Each of the Four Types of Recognition Item.	
APPENDIX D	79.
Summary of the Analysis of Variance for 'YES' Responses for Four Recognition Items (A B C D) on All Forms of the Recognition Test.	
Summary of the Analysis of Variance for 'YES' Responses for two Recognition Items (A B) on All Forms of the Recognition Test.	
APPENDIX E	80.
Frequencies for Confidence Judgments Given at Six Confidence Levels for Four Types of Recognition Item.	
Cumulated Frequencies of Confidence Judgments Cut Off at Five Confidence Levels.	
APPENDIX F	81.
Recognition Frequencies for Individual Subjects in Each of the Four Forms of the Recognition Test.	

ABSTRACT

This study investigated the nature of memory representations constructed from explicit and implied information about two different types of relationships between the objects or actors described in a set of ordered propositions. The propositions described a situation which referred to either an action sequence or to a set of spatial relationships and were presented to subjects in two forms, verbal and pictorial. Ten year old children were given a recognition memory task based on the paradigm used by Bransford, Barclay and Franks (1972). The results showed that subjects had difficulty in distinguishing old recognition items from new situation preserving propositions based on inferences derived from the acquisition sequence, but readily rejected those new propositions that were not consistent with the relationships described in the original premises. This was the case when the original premises were presented in either verbal or pictorial form, and when the relational term used referred to either action sequences or to spatial relationships. An analysis of the results for specific combinations of modality and relational term showed some variation in the general pattern of responses. The construction and integration of inferences into memory representation was facilitated when action sequences were presented in the verbal modality, and when spatial relationships were portrayed in the pictorial modality. Action verbs were found to be particularly sensitive to modality effects.

The concept of 'abstraction' is discussed in the light of the results. It is suggested that this concept is not a unitary one, and that research concerned with the abstraction of memory schema refers to two different types of abstractive process. The distinction between paradigmatic and syntagmatic relationships, originally outlined in Sussure's (1916) study of linguistics, is proposed as a useful way to characterise these processes.

INTRODUCTION

"We act on meanings, not on uninterpreted perceptions."

Chase and Clark (1972, p.226).

A model of remembering and perceiving requires a consideration of the functional and integrative aspects of these processes in order to have utility and relevance at the level of 'psychological reality'. From the late 1960's there has been a considerable shift in emphasis in both memory research and linguistic analysis in this direction. For example a growing concern is evidenced in the research literature with a more detailed analysis of the constructive processes involved in the formation of cognitive representations from verbal and non-verbal stimuli (Wells, 1973).

A central concept emerging from recent studies in these areas is that of schema. The notion of schema is not a new idea in psychology -the first formal statement of the idea was made by Head in 1926 and restated in a modified form by Bartlett (1932) in his influential book Remembering. Bartlett's definition of abstract schema as 'what is learned' was considered as theoretically interesting but difficult to operationalise, and somewhat too 'mentalistic' for the behaviourist orientation of experimental psychology at that time. Recently, however, there have been attempts, in several different areas of psychology, to operationalise the concept so that it could be tested experimentally. For example studies on perception and memory for visual patterns (Evans, 1967a; Posner and Keele, 1968, 1969, 1970), on the recognition and recall of linguistic information (Barclay, 1973; Bransford and Franks, 1971, Bransford, Barclay and Franks, 1972), and experimental work on motor skills (Schmidt, 1974) have all been based on the concept of schema, or the abstraction and representation of patterns or sets of relationships from different types of stimulus information. This interest in abstractive, organizational and constructive processes suggests that future research will bring the fields of language, memory, concept formation and perception into a closer relationship with one another.

This was proposed by Neisser (1967) who utilized the concept of schema in his thesis that perception is not only an active, but also a selective process in which some sort of organization is present even in the simplest of perceptual tasks. The central theme of his book is that 'seeing', 'hearing' and 'remembering' are all constructive acts which make more or less use of stimulus information. The emphasis is not on the properties of the stimulus situation alone, but on the interaction of this with the internal environment of the perceiver. As Vernon (1955) pointed out it is essential in any analysis of our perceptual reactions, to take into account the organized classifications of knowledge about the physical and social environment which inform and influence these reactions. This view is supported by Pylyshyn (1973) who claims that to refer to a cognitive representation from sensory stimulation is to imply that sensory events are highly abstracted and interpreted into a finite set of concepts and relations in order to be represented; what we know about some event or object is therefore equivalent to a finite set of descriptive propositions. Attaneave (1974) presents a similar view and also suggests that future research into memory processes will need to be concerned with a closer analysis of the relational aspects of cognitive representations; research studies will need to take account of the fact that objects in the world are not simply associated, but that they are associated by particular relations. These have quite as much fine structure as objects or classes of objects and it is therefore necessary that these relations be differentiated one from another.

A closer analysis of the relational aspects of the abstractive process in schema theory may well resolve some of the difficulties of this theory as it stands at present. Firstly the concept of schema as originally proposed by Bartlett is perhaps too global to be of very great use in experimental psychology; secondly the concept of abstraction as it applies to the theory is in need of more precise definition and clarification of its referents. Current experimental work based on schema theory reflects both of these difficulties.

The aim of the present study is to examine more closely the relational aspect of the abstractive and constructive cognitive processes which have been suggested by research relating the concept of schema to language and memory processes (Barclay, 1973; Bransford and Franks, 1971; Bransford et al., 1972), and to perception and memory for visual patterns (Evans, 1967b; Posner and Keele, 1968, 1969, 1970).

LITERATURE REVIEW

The Bransford and Franks Approach: The Original Experiments and Related Studies

The contextual approach to meaning illustrated by the Bransford and Franks studies emphasizes the active construction and integration of semantic relationships by the subject. This approach has been labelled "assimilation theory" (Barclay, 1973) and reflects both Piaget's idea of mapping new experience onto existing structures in order to understand the meaning and Bartlett's (1932) account of schema formation which emphasizes the constructive nature of perception and memory.

A classic experiment by Sachs (1967) can be seen as an influential antecedent of this approach. Sachs presented subjects with a recognition set of sentences, some of which preserved the form and others the meaning of sentences embedded in a previously presented prose passage. The results of this experiment indicated that memory for the syntactic features of particular sentences decayed rapidly, whereas the semantic content or 'gist' of a sentence was remembered very much better and for a longer period of time.

In a series of experiments Bransford and Franks (1971), Franks and Bransford (1972), Bransford Barclay and Franks (1972), have demonstrated that adult subjects, when given a list of sentences, integrate meaning relationships into wholistic situational descriptions and forget syntactic information such as which relationships occurred in separate sentences. On the basis of these experimental studies the authors contend that the information available in memory is a function of the linguistic input and of general extra-linguistic information or the subject's knowledge of the world. Sentences are not viewed from this approach as information to be remembered but as information that subjects can use to construct conceptual descriptions of situations. Support for this view has come from several studies, among them Anderson and Ortony (1975), Barclay (1973), Flores D'Arcais (1974), Kintsch and Monk (1972), Singer and Rosenberg (1973).

In their 1971 experiments Bransford and Franks used as materials groups of sentences in an acquisition - recognition paradigm. Four complex sentences were constructed each of which represented the relations among four simple declarative sentences. Each complex sentence was then broken down into its four component simple sentences which were recombined in a number of ways.

The set for each of the four complex sentences consisted of (a) the complex sentence (FOUR); (b) the four simple sentences of this complex sentence (ONES); (c) sentences constructed by combining two simple sentences from the complex sentence (TWOS); (d) sentences constructed by combining three simple sentences from the complex sentence (THREES). No FOURS were included in the acquisition lists. Acquisition sentences from each set consisted of two ONES, two TWOS, and two THREES. These sentences were chosen so that they exhausted the information contained in the complex sentence from which they were derived. A five minute break was given after the acquisition phase and then the recognition list was presented. Subjects were asked to decide, for each sentence, whether they had heard it during acquisition or not and to give a confidence rating to their judgment.

Recognition sentences included sentences actually heard during acquisition (OLD sentences); sentences not actually heard before but consistent with the general ideas expressed in acquisition sentences (NEW sentences); and sentences not actually heard before and not consistent with the general ideas expressed in acquisition sentences (NONCASE sentences).

In general it was found that subjects could not discriminate novel sentences (NEWS) from those heard in acquisition (OLDS) although there was a slight recognition advantage of OLDS over NEWS at the level of ONES. Although subjects were very confident in their recognition responses to novel sentences (NEWS) they were equally confident that they had not heard NONCASE sentences before. Results from this experiment showed that the confidence ratings ordered recognition sentences as follows: FOURS > THREES > TWOS > ONES. This ordering effect has also been referred to as a linear

effect. These results were interpreted by Bransford and Franks as an indication that subjects became less confident of having heard particular sentences as a function of the degree to which a sentence failed to exhaust all the semantic relations characteristic of a complex main idea or situational description. The authors further suggest that their results are reliable evidence that subjects acquired something more general and abstract than simply a list of sentences experienced during acquisition; and that their experimental technique provides a means to investigate the phenomenon of abstraction in considerable detail.

Franks and Bransford (1972) replicated their 1971 study using sentences based on abstract rather than concrete ideas. This replication was indicated by the implications of a research study by Begg and Paivio (1969) which had suggested that concrete sentences may be stored in memory differently from abstract sentences. However results very similar to those of their 1971 experiment were obtained by Franks and Bransford. Subjects in general did not discriminate novel sentences from those heard in acquisition; the highest confidence ratings were given to complex sentences despite the fact that subjects had not previously heard these sentences, nor had they heard any sentences as long as these in acquisition.

These results suggest that there is some similarity in the process of constructing memory representations of both concrete and abstract ideas communicated by sentences. The phenomena demonstrated in these experiments seem clear and are replicable (e.g. Singer and Rosenberg, 1973). The interpretations of abstractive and memory processes made by Bransford and Franks on the basis of these results have not, however, been without critics.

Replications and Critiques. The Role of Instructions

Katz (1973) has argued that the linear effect illustrated in these experiments is an artifact of the procedure used and not anything central to the study of semantics. He considers that

although subjects do attend to semantic meaning and context they also attend to linguistic context and structure; and that task demands are critical in determining which aspects are central in recognition experiments. Despite fairly widespread belief to the contrary Bransford and Franks have never denied this point. They have explicitly stated (1971, p.349) that the boundary conditions for the phenomenon of linguistic abstraction require further investigation and explication and that the effect of instructions on this phenomenon is in particular need of additional research.

Katz used two groups of subjects to replicate Bransford and Franks' (1971) study. The purpose of his experiment was to determine whether the Bransford and Franks results could be obtained when non-semantic criteria are disregarded and recognition is based solely on meaning. The experimental conditions for each group differed only in terms of the type of instructions given. Subjects under one condition were asked to evaluate sentences only according to whether they had actually been heard before (Actual Instructions). Under the other condition subjects were asked to rate sentences using the criterion of whether they meant exactly the same thing as did those heard in acquisition (Meaning Instructions). Two special classes of test sentences were added to the recognition list, 'passives' and 'non-cases'. These were included to check whether the instructions were properly understood. 'Passives' were constructed by using the passive grammatical form of complex sentences heard in acquisition and were very similar or identical in meaning to their active counterparts. 'Non-case' sentences were sentences very similar in form to, but incompatible with the meaning of the complete ideas presented in the acquisition sentences.

Results for this experiment showed that subjects gave high recognition responses to complex sentences (FOURS) under both conditions. In the Actual Instructions condition the linear effect obtained was very similar to that shown by Bransford and Franks. However under the Meaning Instructions condition a large number of recognition responses were given to component idea

sentences thereby markedly attenuating the linear effect. There were no differences between the two groups for 'non-case' sentences. Subjects under both conditions were very sure that they had not heard 'non-case' sentences before. This seems to suggest that extreme changes of meaning are readily detected by subjects even when this aspect of the sentences is not the principal focus of their attention. A main effect for instructions was, however, obtained for 'passive' sentences. In the Actual Instructions condition 'passives' were given the lowest rating of all, indicating that subjects did attend to structure as well as to meaning. Under the Meaning Instructions condition 'passives' were given the highest recognition response indicating that structural differences played little or no role in recognition.

Katz interprets the findings of this experiment as evidence that,

(1) The linear effect is an artifact of the procedure used and not anything central to the study of semantics.

(2) Reliable and fundamentally different processes operate under the two different conditions.

The first point can be conceded as a valid one on the basis of the results of this experiment and the following argument presented by Katz. The explanation of the linear effect offered by Bransford and Franks (1971), namely that recognition is a function of the number of basic ideas in the integrated idea exhausted by the semantic representation of the input, is unrealistic. If true it would mean that individuals are literally unable to recognize small components (basic ideas) in isolation from the whole. The results from the Meaning Instruction condition indicate otherwise.

Katz has effectively shown that the linear effect is sensitive to task demands. However the linear effect is only one aspect of the theoretical assumptions made by Bransford and Franks and it is not by any means the central issue. The basic concern has been rather to demonstrate the occurrence and the nature of abstractive and integrative processes in deriving conceptual knowledge from linguistic information.

The validity of the second point made by Katz above might therefore be questioned on the following basis. Katz has shown that subjects gave high recognition responses to complex sentences that they had never seen before under both sets of recognition instructions. This integrative process cannot, therefore, be considered as an artifact of the experimental procedure only. His results do not seem to provide adequate support for the assumption that 'reliable and fundamentally different processes operate under the two different conditions'.

Overall the value of Katz' experiment has been to underscore a point also emphasized by Jenkins (1974). Recognition phenomena do change when the quality of the event experienced by subjects is changed. The validity of this point does not, however, diminish the evidence in support of the presence of integrating processes in recognition memory. Research to date, (e.g. Barclay, 1973; Flores D'Arcais, 1974; Singer and Rosenberg, 1973) seems to suggest that the integration of linguistic information is, to some extent, dependent on the availability of a global event that makes it possible for subjects to discriminate true descriptive sentences from false ones even though they may not usually be able to discriminate on the basis of the syntactic form or specific content of historic sentences. However from the fact that subjects do not usually discriminate sentences on the basis of specific syntactic information, unless there has been a massive syntactic change as there is with passives, it does not follow that they cannot remember these aspects when specifically asked to do so.

White (1974) has shown that subjects do remember specific syntactic information when exposed to appropriate experimental conditions. White replicated the procedure used by Bransford and Franks (1971) using as materials sentences composed of both abstract and concrete ideas. The abstraction of ideas under an incidental learning condition was compared with an intentional condition where subjects were expected to remember the particular exemplar sentences for the purpose of later recognition testing. For the incidental

learning condition results closely resembled those obtained by Bransford and Franks (1971, 1972) in that the same linear effect FOURS > THREES > TWOS > ONES was obtained. Data from the intentional learning condition, however, indicated that OLD THREES were recognized significantly more often than the novel FOURS. White concludes from this that with a greater emphasis on the retention of specific sentences there is a lesser tendency to abstract the general idea which integrates the sentences. This is a valid point which is given additional support from the results obtained in a study by Barclay (1973).

However the major theoretical thrust of White's paper is his criticism of the interpretation made by Bransford and Franks of the phenomenon illustrated under the incidental learning condition; that is that subjects could not, in general, discriminate novel sentences from those heard in acquisition. In particular the high recognition responses given to FOURS was taken as evidence that the semantic ideas represented by these complex sentences were abstracted from the simpler sentences presented in acquisition.

White argues that a failure to discriminate is confused by these authors with the process of abstraction whereas the method used does not allow reasonable inferences to be made about the occurrence of abstraction. He suggests that when there is abstraction there is little discrimination and therefore seems to view abstraction as a process which can take place independently from the process of discrimination. This contention has some validity if the concept of abstraction is taken as a unitary one with sole reference to the representation of information at a high level of generality or in terms of abstract rather than concrete concepts. However the concept of abstraction is a complex one which is surrounded by a great deal of ambiguity in its reference to memory research. The issue has been further confused by the somewhat cavalier use of the term by Bransford and Franks themselves as in the following example.

"Subjects acquired something more general or abstract than simply a list of sentences" (1971, p.348).

Posner (1973) has observed that the term 'abstraction' is often loosely used but can be taken to refer to either,

- (1) The classification of information input at a higher level of generality as in the formation and use of abstract concepts (Piaget, 1954; Vygotsky, 1962).
- or
- (2) Selection of part of the information input which is either generalised or combined with other selected aspects to create a new integration (Bartlett, 1932; Gibson, 1969; Neisser, 1967).

This use of the term 'abstraction' is consistent with the theoretical assumption that perception and cognition are active processes of selection, organization and construction.

This second definition of abstraction is referred to by White in his paper and can be taken as related to his argument. White has shown that a greater emphasis on the retention of specific sentences lessens the tendency to abstract the general idea that integrates the sentences. Under these conditions sentences are likely to be regarded as separate entities and discrimination or perception of differences as a process can therefore stand alone. Within the context of Posner's second definition of abstraction, however, it seems reasonable to suggest that the processes of abstraction and integration cannot stand alone but necessarily entail the assumption that a prior process of discrimination has taken place. White's contention that when there is abstraction there is little discrimination does not seem applicable within this context for the following reasons. The phenomenon illustrated by Bransford and Franks (1971, 1972) where subjects integrated separately experienced ideas into wholistic descriptions, suggests that these ideas had been previously discriminated from their original syntactic context in order to be so integrated. If conceptual representations are constructed on the basis of the discrimination of a selected aspect of the input (such as ideas) it does seem likely that

subjects will fail to discriminate on the basis of other aspects of recognition sentences (such as syntactic form) which have not been integrated into their conceptual representations. Failure to discriminate at this level, however, does not seem to be a reliable indicator that discrimination and abstraction have not taken place in constructing the semantic description of the situation that the subject does recognize or recall.

The Integration of Extra-Linguistic Inferences

The criticisms made by Katz and White refer only to the claims made by Bransford and Franks on the basis of their earlier experiments (Bransford and Franks 1971, Franks and Bransford 1972). However in these particular experiments the authors did not specifically investigate the construction of wholistic descriptions allowing extra-linguistic inferences. Reid (1974) has pointed out that despite fairly general acceptance of the fact that memory for meaning or the 'gist' of a sentence (Fillenbaum, 1966) is better than verbatim memory, the fact remains that little progress has been made in determining the reason one remembers certain 'gist' and is unable to remember other. This point can also be made in reference to extra-linguistic inferences made in comprehension. Although Sachs in 1967 had suggested that we need to find out more about just what kinds of information people tend to add in comprehending language very little research attention had been given to this question prior to the Bransford, Barclay and Franks (1972) experiments.

The basic assumption underlying the constructive approach to language processing is that the comprehension-memory system is a selective one which uses information from the input sentences combined with stored knowledge about the world and contextual constraints such as task demands to generate a conceptual representation of the situation that is meaningful to the subject. Extra-linguistic inferences contribute to these representations to a variable degree. The occurrence of inferred relational and conceptual information in subject's recall of

discourse has been noted by Dawes (1966) and Frederiksen (1975). Bransford et al. (1972), in a series of experiments examined the hypothesis that certain types of information may facilitate the construction of semantic descriptions that contain more information than is explicitly stated in the acquisition sentences.

Experiment III is selected from this series as a prototype of the approach used. Two groups of subjects were given the acquisition task of listening to a number of descriptive passages like the following.

"There is a tree with a box beside it and a chair is on top of the box. The box is to the right of the tree. The tree is green and extremely tall." (1972, p.201).

Following acquisition subjects were presented with one of two recognition sets and asked to indicate which sentences from each block they had actually heard before. The first recognition set, (Set A) contained sentences that were in the acquisition passages (OLDS) and sentences that were not (NEWS). Some of the NEWS were consistent with the overall situational description presented in acquisition, (e.g. the chair is to the right of the tree) and some of them were not (e.g. The chair is to the left of the tree). The recognition set for this example was.

Set A

- | | | |
|----|--|-----|
| A. | The box is to the right of the tree. | OLD |
| B. | The chair is to the right of the tree. | NEW |
| C. | The box is to the left of the tree. | NEW |
| D. | The chair is to the left of the tree. | NEW |

Bransford et al. reasoned that according to the constructive approach subjects would be likely to remember something about the particular style, but given that they should forget this, they should not be reduced to total guessing. Instead they should pick sentences consistent with the overall situational description even if such sentences were not heard in acquisition. They predicted that for Recognition Set A subjects would be very likely to pick sentences based on situation-preserving inferences such as sentence B above.

A second recognition list was constructed based on the fact that there are a number of linguistically different ways to describe the same basic situation. Recognition Set B was identical to Set A except that the subject and object nouns were reversed as well as the relational terms. Although there were no sentences that were actually OLD for this set, sentences such as A below were referred to as OLD since they preserved the semantic relations between objects referred to in the acquisition passage.

- | | | |
|----|--|-----|
| A. | The tree is to the left of the box. | OLD |
| B. | The tree is to the left of the chair. | NEW |
| C. | The tree is to the right of the box. | NEW |
| D. | The tree is to the right of the chair. | NEW |

For this recognition set the authors hypothesised that if recognition is primarily a function of syntactic information subjects should be very confused by these items. If, however, recognition can be based on an abstracted semantic description of the situation then subjects should show a strong tendency to make 'situation-preserving' errors and judge sentences A and B as OLDS more often than sentences C and D.

The results from this experiment supported the predictions generated from the constructive approach. For both groups situation-preserving responses accounted for 70% of the total recognition responses made. For Recognition Set A the greatest number of recognition responses were given to OLD sentences indicating some tendency to remember the linguistic form in which the information was originally presented. However there was also a significant tendency to pick situation-preserving NEW sentences based on inferences derived from the overall description heard in acquisition (such as sentence B) in preference to situation-distorting sentences (such as sentences C and D).

For Recognition Set B in which no sentences were actually identical to those previously heard, there was no significant differences between recognition responses for OLD sentences, and NEW sentences based on situation-preserving inferences (Sentences A and B in Recognition Set B) despite the fact that the OLD sentences preserved the conjunction of the

the content nouns heard in acquisition sentences while NEW inferences did not. However there was a significant tendency to pick situation preserving NEW sentences in preference to situation distorting NEW sentences (such as sentences C and D). Bransford et al. have suggested that these data provide especially strong evidence for the constructive approach to sentence memory. If subjects were simply storing information as to which objects were related to others in the acquisition sentences they should have been very confused by Recognition Set B and should therefore have picked many situation-distorting sentences. However the 70% recognition response given to situation-preserving sentences does not support this expectation.

Bransford et al. in their evaluation of this series of experiments, have emphasized that the role of context in the comprehension and recall of linguistic information refers to more than the information input from the external environment. The internal environment, or the subject's knowledge of the world is also an essential component of these processes. Linguistic theories which restrict the characterisation of comprehension-memory processes to an analysis of syntax and semantics as do those of Katz and Fodor (1963) and Clark and Clark (1968) do not therefore seem adequate as explanatory models of these processes. The constructive approach can be seen as an attempt to overcome these limitations.

The Organization of Stimulus Information

Research to date (Barclay, 1973; Green, 1975; Rosenberg and Jarvella, 1970) has suggested that a prerequisite for the generation and **integration** of inferences is the condition that the stimulus information is organized to outline some overall description of an object or a situation. The inference process fills in or assimilates extra-linguistic information to the general outline of the situation that the subject has in mind.

Some evidence for this contention is provided by a study made by Rosenberg and Jarvella (1970). Noise was introduced as a variable in an incidental learning experiment utilizing two types of sentences, semantically well integrated sentences (sentences which conveyed a

coherent and meaningful description) and semantically poorly integrated sentences. When a portion of the acquisition sentences was masked by noise to a degree that the masked portion was unintelligible, subjects showed an increased tendency to generate and integrate extra-linguistic inferences over acquisition conditions where sentences were not masked in this way. This effect was limited, however, to sentences presented in acquisition in a semantically well integrated form. Subjects were not able to generate and integrate inferences for those sentences which were semantically poorly integrated.

Barclay (1973) ran a series of experiments designed primarily to investigate the role of logical operations (e.g. transitive operations involving spatial terms such as left-right and comparative terms such as taller-shorter) in the construction of memory representations. In each of these experiments a structured array of objects was described in acquisition in piecemeal fashion by a list of semantically related sentences. The list of sentences embodied both expressed and implied information. This implied information had to be inferred in order to correctly construct a representation of the overall array. The most general finding from these experiments was that in both recognition and recall tasks, subjects not only remembered previously presented sentences but also implied but unstated inferences; they drew a sharp line only between true and false sentences, thinking that they were distinguishing old sentences from new ones.

In one of the five experiments in this series, however, two different sets of instructions were given to two groups of subjects. Those subjects who were informed that the acquisition sentences described an overall array did not discriminate old sentences from new ones, but were able to correctly recognize the array in 82% of cases. Those subjects who were not informed of the existence of an overall array, but who were asked only to memorize the sentences, tended to treat the acquisition sentences as discrete linguistic entities and thus were better able to distinguish new sentences from old ones. However this group of subjects was able to recognize the overall array in only 10% of cases.

This finding provides further substance to the points raised by Katz (1973) and White (1974) which were discussed in an earlier section. Task demands are a critical variable in determining what kinds of memory representations subjects do construct. However the tendency to treat a sentence mainly or only as a linguistic object seems usually to be confined to situations where subjects are specifically instructed to do this.

In summarizing his 1973 paper Barclay outlines the basic assumptions of the constructive approach (or assimilation theory) which is common to the research studies outlined in this and previous sections. He states,

"The fundamental component of assimilation theory is the comprehension device which relates sentential information to one's knowledge system, in part through logical operations. In this respect sentence comprehension is simply one manifestation of the general process referred to as knowledge acquisition. (1973, p.253)."

This view, although intuitively satisfying and supported to some degree by the experimental work outlined, is in essence general and diffuse and leaves open a number of important issues. Two of these issues are noted here.

Clark (1973) has pointed out the fallacy (Language - as - Fixed - Effect - Fallacy) of trying to draw scientific conclusions from studies of verbal behaviour if the effects demonstrated are restricted to the specific language materials used in the experiment. The previously outlined studies by Bransford et al. (1972) and Barclay (1973) examined the role of extra-linguistic inferences in sentence memory only in terms of inferences made on the basis of logical operations and spatial relationships. In the light of Clark's statement it seems necessary, therefore, to ask the following question. To what extent does the relational nature of the stimulus information presented constrain the range and types of inferences generated by subjects?

A further question related to these studies arises from Barclay's outline of assimilation theory quoted earlier, and is based on the claim

that within the context of assimilation theory sentence memory is simply one manifestation of a more general process of knowledge acquisition. If the process of inference generation and integration is a general process then can it be shown to operate if stimulus information is presented in other forms, for example in pictorial rather than in verbal form?

Experimental studies and theoretical views relating to each of these questions will be reviewed in the following sections.

The Relational Aspects of Sentence Comprehension and Memory

Data from the preceding experimental studies suggests that peoples' internal memory representations of sentences often contain elements which could not be derived solely from the constituent words. Anderson and Ortony (1975) have pointed out that there are only two possible sources of this information: context and existing knowledge. In order to evaluate the relationships that hold among the features from which meaning is extracted it seems necessary to work within some kind of conceptual framework. Craik and Lockhart (1972) have proposed a model which seems to have utility for this purpose. This model suggests that the extraction of meaning is related to varying depths of processing and reflects the influence of theorists from the fields of perception (Neisser, 1967) and linguistics (Lamb, 1966). The central contention of all of these models is that the perception of stimuli involves a number of levels or stages. Physical or sensory features are analysed in the preliminary stages, but later stages involve the interpretation and organization of input in terms of a conceptual representation which is based on prior learning and experience. The application of the model proposed by Craik and Lockhart to memory research indicates a shift away from a strongly linguistic orientation to an emphasis on perceptual events and their relation to the language structure. Some support for this view is given by Craik (1973). He reports several experiments in which depth of processing was varied by requiring subjects to perform different tasks on single word acquisition

items; for example either judging whether the word was in capital letters or whether it fitted into the context of a given sentence. The more semantic tasks were presumed to involve a deeper processing level, and it was found that these tasks took subjects a longer time than did tasks related to the physical features of the acquisition words. Memory over a time delay was also found to be better for those items on which the deeper processing task had been performed. A number of recent experimental studies of memory processes have also been based on this theoretical approach, among them Clark, Carpenter and Just (1973) and Anderson and Ortony (1975).

A further contribution to the clarification of the relational aspects of sentence comprehension and memory has been given by Reid (1974) who has proposed that a sentence is represented at the conceptual level in terms of the structure of the various relational roles connected with key words in the sentence. Constraints on the use of language at the psychological level reflect two different kinds of relationships - paradigmatic and syntagmatic relations. These terms have had a long history in the study of linguistics (Sassure, 1916/1959) and have been reintroduced into the study of language behaviour mainly through the influence of Jakobson's clinical work in aphasia (Jakobson and Halle, 1971). Similarity or paradigmatic relations refer to the shared conceptual features that characterise a given paradigmatic set; these relations are important in experimental tasks that require subjects to detect the presence or absence of features in stimuli and also in classification tasks. Contiguity or syntagmatic relations, on the other hand, are not based on similarity or difference of features but refer to the relationships that hold between the features of a represented situation or event. These relations are important in tasks that require a subject to remember some event or situation in terms of the relationships that hold between objects or actors participating in it.

Statements involving syntagmatic relations can be further distinguished as falling into two broad categories; statements describing the spatial relationships between objects and those which describe one object acting upon another. According to Huttenlocher (Huttenlocher, Eisenberg and Strauss, 1968) these two types of relational statements differ in the

following way. Statements describing spatial relationships merely indicate the order of items along some dimension (such as left-right). The two complementary ways of describing this order are both simple statements, neither has a passive form. A lack of correspondence between the form of a relational statement and the extra-linguistic situation it describes can be corrected by transforming the relational statement to co-ordinate it with the subject's conceptual representation of the situation. This transformation of the relational term is not possible with statements describing one object acting on another without distorting the meaning of the event described in the statement.

In experiments using five and nine year old children as subjects Huttenlocher and Strauss (1968), Huttenlocher et al. (1968) investigated the following hypotheses.

A. One's understanding of a statement depends upon the relation between that statement and the extralinguistic situation it describes. Therefore comprehension is easiest when there is a correspondence between the perceived actor and the logical subject of the experimenter's statement.

B. The nature of the intellectual operations involved in co-ordinating the perceived actor with the logical subject will be different for relational statements than for statements describing one object acting on another.

The first of these experiments investigated Hypothesis A in terms of spatial relations. The subject's task was to place a mobile block (MB) above or below a fixed block (FB) in a ladder-like structure with five shelves in order to make a pile. Two types of problems were used; (1) when the subject of the experimenter's statement was the mobile block and the object the fixed block. 'The MB is above/below the FB.' and (2) when the subject of the experimenter's statement was the fixed block and the object the mobile block. 'The FB is above/below the MB'. The results of this experiment showed that for all ages more

errors were made when the mobile block was the object rather than the subject of the experimenter's statement.

The second experiment in this series (Huttenlocher et al., 1968) was analogous to the block task except that it involved statements that described one object acting on another. In this case materials used were toy trucks which were required to push/pull one another. The results showed that the phenomenon observed earlier with relational statements also holds when subject and object are linked by ordinary motion verbs like 'push' and 'pull'. That is, it is easier to place an object described as grammatical subject than vice-versa. This was true for both active and passive sentences.

A comparison of subjective accounts of the intellectual operations engaged in during these tasks suggested that these may differ according to the relational terms used. With spatial terms subjects transformed the experimenter's statement, where necessary, to make the mobile object its subject. With action statements, however, subjects co-ordinated the statement with the extralinguistic situation, when necessary, by imagining that the fixed object was in fact the mobile object.

The major findings of Huttenlocher's experiments have been confirmed in a study by Olsen and Filby (1972) using adult subjects. When a perceptual event is coded in terms of the actor, active sentences are more easily verified than passive ones. The reverse is true when the event is coded in terms of the receiver of the action. Similar results were obtained in an earlier study by Tannenbaum and Williams (1968).

Carey (1964) and Wason (1965) have each suggested that a possible mechanism by which a particular statement may be harder or easier to understand is its plausibility within a given context. Wason found that the main factor influencing whether a negative statement is more difficult to verify than a positive one is whether it is plausible within the context in which it is uttered.

The theoretical views and experimental studies reviewed in this section have each been concerned with some dimension of the relational aspect of language comprehension and memory but do not, either

individually or in combination, constitute an explanatory model of the underlying processes involved. At best they offer descriptive data which suggests in outline some of the components which need to be taken into account in constituting such a model and indicate some directions in which further research could prove productive. Craik and Lockhart (1972) and Huttenlocher et al. (1968) have each emphasised the importance of perceptual events and their relation to the language structure and to the comprehension process in general. However as Trabasso (1973) points out we cannot, on the basis of these or similar studies (e.g. Clark, Carpenter and Just, 1972), assimilate all concepts to percepts despite the fact that some primitive concepts seem to be derived from particular perceptual configurations (Michotte, 1963; Miller, 1972). Michotte's classic series of experiments demonstrated that definite combinations of objects in space and time were conducive to causal interpretations of events, while Miller has provided a comprehensive analysis of verbs of motion showing how the meanings of a large body of lexical items could be expressed in terms of a small set of concepts and conceptual relationships.

These studies provide some basis for a more differentiated conceptual approach to this area. The work of Huttenlocher et al. (1968) in addition suggests, but by no means confirms, that different types of intellectual processes may be brought into play in reconciling linguistic descriptions with the extra-linguistic situations they portray depending on the type of relational concept employed in a particular study; descriptions of spatial relations between objects seem to be processed differently from statements describing one object acting on another.

A further useful distinction is indicated by Jakobson's distinction between paradigmatic and syntagmatic relations. The clinical study of different types of aphasia (Jakobson and Halle, 1971; Luria, 1973) provides some evidence for a psychological reality to this distinction in addition to the semantic one. As Reid (1974) has stated, these two types of conceptual relationships can be shown to be related to the demands of different memory tasks. However with some exceptions

(e.g. Bransford et al. 1972; Miller, 1972) there has been little direct investigation of syntagmatic relations in psychological studies to date.

The importance of context in rendering the described or perceived situation meaningful to the subject has been a pervasive theme in the work reviewed in this and previous sections. Wason's (1966) concept of 'plausibility', the studies on inference generation (Bransford et al., 1972; Barclay, 1973) and Craik's (1973) experiments on depth of processing are examples which illustrate varying aspects of the role of context in memory and comprehension processes. Task demands for recognition or recall of intrinsically meaningless material place a predominant emphasis on the external environmental context; those which facilitate the generation of extralinguistic inferences emphasise the internal environment or the subjects conviction of what is required to construct a meaningful internal representation of the situation or event.

In the light of Barclay's comment, noted earlier, that the constructive approach to sentence meaning is but one manifestation of a more general process of knowledge acquisition, the following section will be concerned with a brief review of studies concerned with the process of abstracting conceptual schema from visual and pictorial information. The relational and contextual aspects of this process will be of particular concern.

Schema Formation: Abstraction from Visual and Pictorial Material

Posner (1969) on the basis of findings from a number of experiments using visual patterns as stimulus materials (Evans, 1967b; Posner and Konik, 1966; Posner, Goldsmith, and Wilton, 1967; Posner and Keele, 1968, 1969). has concluded that retention of previously perceived events is not as vivid or complete as the original perception. The two main explanations he proposes for this conclusion are, (a) that selective attention leads to the storage of some aspects of a scene

rather than others, and (b) that stimuli as originally processed may lose specificity as more general classifications are achieved. These principles are in general outline consistent with those found to operate in similar research using prose passages or groups of sentences (Barclay, 1973; Sachs, 1967).

Most studies of schema formation have used some form of random visual patterns. The basic pattern is called the prototype. A number of transformations of the prototype are constructed varying in degree of distortion from the original pattern. The prototype thus represents the central tendency or communalities among the derived patterns and constitutes the 'schema'. A number of studies have shown that in classification tasks subjects are able to separate patterns derived from one central tendency or prototype from those derived from another without prior instruction and without receiving knowledge of results (Evans, 1967b).

Posner (1969) has suggested, however, that the ability of human subjects to learn to identify patterns that are instances of different central tendencies is not in itself sufficient evidence that this type of classification involves the abstraction of a schema. A series of experiments was designed to investigate this question (Posner and Keele, 1968, 1969). Materials used in these studies were patterns of nine dots printed on separate cards. Subjects learned to associate four different distortions from each of a number of prototypes with one another by a paired-associate technique. Subjects were then presented with a list of patterns and asked to classify them in terms of which patterns belonged together. The list consisted of (1) the prototypes which they had not seen before; (2) old distortions which they had just finished learning and (3) control patterns which were within the learned category. Some of the control patterns were designed to have the same degree of distance from the four learned patterns as did the prototype but were not themselves the prototype. The results of this experiment showed that the prototypes were correctly classified significantly more often than any of the control patterns. Posner interprets these results

as an indication that the process of classifying patterns does not rely solely upon the distance relationship from a particular stored exemplar, but rather on the distance of the new pattern from those aspects of the stored pattern that represents qualities common to all the exemplars. This view is consistent with that of Garner (1966) who proposed that one's knowledge is a function of the perception of properties of sets of stimuli rather than of the properties of individual stimuli.

To observe what happens to the process of schema formation over time Posner and Keele (1969) replicated their 1968 experiment with the addition of a control group who experienced one week's delay between learning the original patterns and being exposed to the classification task. Results from this experiment indicated that after one week's delay the schema or prototype was recognized at least as well as the particular patterns the subjects had learned. The time delay increased the number of classification errors made for the memorised patterns in comparison with the number of errors made for these patterns under the no delay conditions. The number of errors made in classifying the schema or prototype patterns did, however, show a definite decrease after one week's delay from the error level recorded under the no delay condition. Posner contends that it is reasonable to interpret these results as evidence that the abstraction of information concerning the central tendency takes place during learning rather than being later mediated through individual stored patterns.

Franks and Bransford (1971) extended the work on schema abstraction from visual patterns as developed by Posner and Keele (1968, 1969) on the basis of their view that the nature of the stimulus materials used in these experiments (configurations of dots) limited the possibility of a structural specification of the nature and genesis of the schema derived. Franks and Bransford constructed a series of structured spatial configurations of well-defined forms (triangles, squares and other geometric shapes), constituting a number of prototypes and from these generated a set of transformations constrained by a set of discrete deterministic rules. In a series of four experiments utilizing an acquisition-recognition paradigm subjects were exposed to items which were instances of patterns that varied in transformational distance from the prototype. In a subsequent recognition test subjects were

given a set of items consisting of (a) the prototypes which they had not previously seen and (b) transformations from the prototype which varied in transformational distance from it. Results from these experiments showed that in all instances the prototype received the highest recognition rating despite the fact that it had not been previously seen by subjects. For all other items subject's recognition ratings were found to be inversely related to the prototype. Franks and Bransford consider that their results support a schema plus transformations model of memory representation for patterned visual materials. According to this view the schema reflects the interrelationships among the acquisition configurations and the communalities abstracted from these. These conclusions are in substantial agreement with those expressed by Posner in summing up his earlier experiments on schema formation (Posner and Keele, 1969).

Evans (1967a) has defined schema theory as referring to a population of objects all of which can be efficiently described by the same schema rules. A schema rule is abstracted as a set of commonly occurring characteristics in a collection of otherwise different instances. The prototype experiments outlined above are in conformity with this definition. However Evans considers that, "Schema theory, as described above,

"is clearly inadequate to deal with ordinary human perception. The environment does not, in general, provide a collection of stimuli belonging to the same schema family. Instead instances of various schema families are normally mixed together (1967a, p.87)."

Evans proposes that the mixed schema condition requires that schema theory be extended beyond an investigation of how people remember patterns to the area of concept formation and concept utilization. It is at this point that schema theory extension can be seen to merge into the constructive approach to meaning that has been the central focus of this review.

Work on the abstraction of schema from visual patterns has been almost solely concerned with the relation of similarity or the

paradigmatic pole of the paradigmatic-syntagmatic distinction in the construction of conceptual representations. To date there has been virtually no experimental work in this area to parallel the investigations of the syntagmatic pole of this distinction as there has been in studies utilizing verbal materials.

One reason for this could be based on a finding by Shepard (1967) that surface recognition memory for pictures is strong and of long duration. Shepard investigated recognition memory for groups of approximately 600 stimuli consisting of either words, sentences or pictures. Correct recognition responses for these groups of approximately 600 stimuli consisting of either words, sentences or pictures. Correct recognition responses for these groups of stimuli were respectively 90%, 88% and 98% under no delay conditions. Even after one week's delay recognition memory for pictures remained as high as 90%. From this it could be concluded that subjects would be very unlikely, in studies using pictorial materials, to confuse implicit information or meaningful inferences with explicit information as has been shown to occur in studies using linguistic materials (Barclay, 1973; Bransford *et al.*, 1972).

However the point is often overlooked that Shepard obtained a very high recognition response also for words and sentences (90% and 88% respectively) although responses for these stimuli did not reach the level obtained for pictures. A possible explanation for the strong surface or verbatim memory illustrated by these results could be that in Shepard's study the three types of stimuli were presented as a series of discrete entities. As noted previously the generation of inferences, which constitutes one source of confusion in recognition tasks, seems to depend on the prior organization of stimulus information in a way that outlines some overall description of an object or a situation (e.g. Rosenberg and Jarvella, 1970).

* A recent study by Baggett (1975) used an acquisition recognition paradigm to investigate the nature of memory representations for two types of picture stories; surface information arising from pictures which occurred in the stories and conceptual information inferrable when integrating the pictures into a connected story but not originally explicitly presented in the stories. Materials used in this experiment

were stories consisting of four pictures which outlines a simple but coherent series of events. The target picture in each story sequence consisted of two versions, one explicitly portraying an event in the sequence while the other required that inferences be generated about the occurrence of this event from the context and sequence of other pictures in the story. Subjects in the acquisition phase of the experiment saw versions of the story sequence which contained either the explicit or the implicit target picture. The recognition task was to identify whether the explicit target picture was an event in the original story sequence. Baggett proposed two hypotheses. The first of these was that with no delay between acquisition and recognition reaction times for recognition would be faster in those cases where the explicit target picture was included in the original story sequence the subject viewed. In those cases where the event portrayed by the target picture had to be inferred as occurring in the sequence, reaction times for recognition were expected to be slower. The second hypothesis was that with a 72 hour delay between acquisition and recognition the differences in reaction time between the two groups of subjects in recognizing the target picture should markedly decrease. However it was not expected that the difference would entirely disappear in the light of Shepard's (1967) finding that surface memory for pictures is vivid and of long duration.

Results from this experiment confirmed both of the hypotheses. A very much slower reaction time for recognition of the target picture was recorded for subjects who had originally seen the story sequence containing the implicit target picture than for those who viewed the story sequence containing the explicit picture. However after a 72 hour delay the differences in recognition reaction time between the two groups of subjects were found to differ only very slightly.

Baggett interprets these results as an indication that the surface memory trace which aided faster access to recognition of explicitly descriptive pictures under the no delay condition was no longer available after 72 hours; the essential representation

remaining in memory at this point is likely to be a conceptual and probably not a pictorial one.

In an extension to this experiment Baggett investigated the role of instructions on surface memory for pictures. When explicit instructions were given to subjects to memorize only the precise individual pictures seen it was found that even after 72 hours subjects made no false recognition responses at all and reaction times were short. It seems that surface memory for pictures is strong and of long duration under the following conditions; (a) if task demands require this and (b) if pictures are regarded as discrete visual entities rather than as surface cues to an underlying meaningful description of a situation.

Baggett included one further experiment in this study. This was designed to test the hypothesis that reaction time differences would disappear if subjects, after viewing either the explicit or the implicit versions of stories, were asked to respond either 'yes' or 'no' to written questions describing the target event in the story sequence. The rationale given by Baggett for this hypothesis was that subjects who were actually shown the explicit version of the story would have to infer the answers to the verbal questions in much the same way as would subjects who originally saw only the implicit version; this would be so because a direct surface match would not be possible because two modalities, verbal and pictorial were involved. The results of this experiment confirmed the hypothesis. Reaction time differences between the explicit and implicit conditions which operated in the first experiment in this series were virtually eliminated. In fact a very slight reaction time advantage was recorded for those subjects who had earlier viewed the implicit version of the story.

Baggett interprets these results as an indication that subjects, regardless of whether they had viewed the explicit or the implicit story version, were responding from the same basic conceptual representation of the situation. She suggests that this finding gives some empirical support to Pylyshyn's (1973) contention that conceptual memory for pictures is basically propositional or descriptive in nature.

Pylshyn's concept of propositional knowledge is derived from the seminal work of Frege (1879/1960) and is based on the notion that the proposition is a description, an assertion or a meaning which can be conveyed by a number of different symbolic forms but is itself not logically dependent on any particular one of them. Experimental work by Carpenter and Just (1975) and Clark and Chase (1972) has also given support to Pylshyn's theoretical position. In summing up their 1975 series of experiments Carpenter and Just stated that their findings give support to the view that (a) sentences are internally represented as an ordered set of constituents in an abstract propositional format; (b) other information sources (such as pictures) are also represented in similar format.

The experiments reviewed in this section give some support to the view that the processes involved in constructing conceptual representations from visual and pictorial material are, in general, very similar to the processes found to operate when the stimulus information is presented in linguistic form. The constraints which affect the types of memory representations formed are also similar. For example, task demands to some extent determine whether the predominant emphasis will be on the retention of surface form in contrast to a more conceptual representation. However the work of Baggett (1975) and Posner and Keele (1968, 1969) has indicated that this distinction becomes less clear-cut over time. As was illustrated in verbal studies (e.g. Barclay, 1973; Rosenberg and Jarvella, 1970) the subject's awareness of the presence of an overall event in tasks involving pictorial stimuli seems to facilitate the generation of inferences which can be one source of recognition errors. Contrasting the results obtained by Baggett (1975) with those of Shepard (1967) gives tentative support to this view. However both of these studies also suggest that a difference, but one of degree rather than of kind, seems to obtain between memory for pictorial material and that for verbal material; that is, a subject's surface memory for actually viewed pictures, although sensitive to experimental conditions and task demands, tends to remain accurate and extant for a longer time

duration than does verbatim memory for verbal material (Keenan, Kintsch and McKoon, 1974).

This factor could be expected to influence, to an as yet undetermined degree, some differences in responses in memory research involving the abstraction of meaning from visual or pictorial materials in contrast to the responses given when the stimulus materials are linguistic in form.

THE PRESENT STUDY

Bransford, Barclay and Franks (1972) used as materials verbal descriptions of spatial relations between objects to investigate the hypothesis that certain types of stimulus information may facilitate the construction of cognitive representations containing more information than was originally explicitly stated. The present study although not an exact replication is based closely on Experiment III in the Bransford *et al.* (1972) series. The following experiment also utilized verbal materials, but in order to attenuate the Language - as - Fixed - Effect problem (Clark, 1973), extended the types of relational terms used to include both spatial relations and action verbs. There are certain fundamental differences between these two language populations. Spatial relations between objects do not of necessity involve a temporal dimension whereas relationships between objects based on action sequences do. In the former instance inferences can be derived from logical operations; in the latter empirical probability is the basis for the derivation of inferences. This point will be elaborated further on the section on Method.

A further direction in which the present study differs from and extends that of Bransford *et al.* is that the stimulus information is also presented in pictorial form. The original work on the abstraction of schema from visual materials (Posner and Keele, 1968, 1969) was concerned only with paradigmatic relations. Evans' (1967a) suggestion that schema theory be extended to include the mixed schema condition (syntagmatic relations) was the principal basis for this modification and extension. (The work of Baggett (1975) who investigated syntagmatic relations using pictorial material became available only after the experimental work for this study had been completed).

A general background aim of this experiment was an attempt to clarify the referents of the concept of 'abstraction' as it has been used in experimental work based on schema theory. For this reason ten year old children were used as subjects. One definition of the concept of 'abstraction' given by Posner (1973) is that it refers to the classification of information input at a higher level of generality. However the process of forming abstract concepts or formal operational thinking is not, according to Piaget (1954) and Vygotsky (1962), generally reached before the age of twelve or thirteen. If this is the process involved in the abstraction of schema from verbal and pictorial materials it seems very unlikely that it could be utilized by children at younger ages. There is, however, a substantial body of research (Bloom, 1970; Deese, 1969; Halliday, 1968; Kuczajii, 1975; MacNamara, 1972) which gives substance to the assumption advanced by Nelson (1974) that quite young children translate the dynamic relations between objects into conceptual core meanings to which identification features such as language are attached. This view is in accord with Posner's alternative definition of the concept of 'abstraction' which refers to the process whereby a part of the information input is combined with other selected aspects to create a new integration. Support could be given to the view that abstraction of schema from verbal and pictorial information involves a process consonant with this definition of the concept if it could be shown that ten year old children, who have not attained the level of formal operational or abstract thought, do in fact abstract such schema. The generation of extra-stimulus inferences and the confusion of these inferences with explicitly stated information in a recognition task could provide some evidence that schema formation has taken place.

Against this general background aim the following specific hypothesis will be investigated.

According to the constructive approach it is expected that children who have not reached the stage of formal operational thinking will form a schema of an overall

situation or event described by stimulus information. Therefore they are expected to confuse situation preserving inferences with explicitly stated information in a recognition memory task. This process is expected to operate when, (a) the stimulus information is presented in either verbal or pictorial form and (b) when the relational terms used differ at the conceptual level, as do spatial terms and action verbs.

As a corollary to this it is suggested that surface memory for pictorial material is more accurate than it is for verbal material (Baggett, 1975).

A second and subsidiary hypothesis is also to be investigated. There have been some suggestions in the research literature (Neisser, 1972; Werner and Kaplan, 1973) that the pictorial modality is better adapted to conveying spatial information, whereas the verbal modality is more suited to conveying information about action sequences.

It is therefore hypothesised that the confusion of inferences with explicitly stated information is more marked when spatial relations in contrast to action verbs are presented in pictorial form; and when action sequences in contrast to spatial relations are presented in verbal form.

METHOD

Design - A 2 X 2 between-subjects factorial design was used with two types of modality (verbal and pictorial) and two types of relational term (action verbs and spatial terms) resulting in four forms of the test.

Materials - Four story sets were constructed for each of the two types of relational term. Each story set consisted of an acquisition sequence of three sentences which described an overall situation or event. There was also a recognition sequence for each story set. The recognition sequences consisted of a block of four sentences. One of these was the old sentence actually heard during acquisition (OLD. True Premise); one was a situation-preserving inference derived from the OLD sentence (NEW. Permissible Inference); the third was a situation - distorting sentence (NEW. False Premise) and the fourth consisted of an inference derived from the situation - distorting false premise. (NEW. Non-permissible inference). Pictorial versions of the acquisition and recognition sequences of each story set were also constructed. Both sentences and picture sequences were designed to conform to a basic paradigm in order to ensure conformity across story sets at the conceptual level. The basic paradigm for story sets using spatial terms was derived from the following simplified version of the example used by Bransford, Barclay and Franks (1972).

ACQUISITION.

- (1) The box is to the right of the tree.
- (2) The chair is on top of the box.
- (3) The tree is green and tall.

RECOGNITION.

- A. The box is to the right of the tree. (OLD. True Premise)
- B. The chair is to the right of the tree. (NEW. Permissible Inference)
- C. The box is to the left of the tree. (NEW. False Premise)
- D. The chair is to the left of the tree. (NEW. Non-permissible Inference)

Within the constraints of the paradigm (See Appendix A) derived

from this example, story sets using the following spatial terms were constructed: right - left, above - below, in - front - of - behind, higher - lower (See Appendix A).

The basic paradigm for story sets using action verbs as the relational term was designed to conform as closely as possible to that used for story sets based on spatial terms; there was, however, some difference between them. This was necessitated by a basic difference that operates between the two types of relational term at the conceptual level. Spatial relationships between objects can be described adequately as a static layout using the present tense only. Permissible inferences derived from this type of description are based on logical operations. For example, from the two propositions 'A is to the left of B' and 'B is to the left of C' the proposition 'A is to the left of C' is deriveable. Permissible Inferences constructed from the acquisition sentences in the story sets for spatial terms were all of this type.

In contrast action sequences imply movement which always involves a temporal dimension. Inferences derived from descriptions which relate objects to one another through action verbs can never be based on logical necessity. There is always the possibility that any one of a range of possible actions could have taken place. For example, from the propositions 'John hit the ball' and 'Something broke the window' it is possible, and reasonable in certain contexts, to derive the proposition 'The ball broke the window'. This inference, however, is based on empirical probability and not on logical necessity. The empirical probability of the implied action constructed from the general context of the acquisition sentences was therefore used as the basis for recognition sentences defined as Permissible Inferences in the test forms for action verbs.

Within the constraints of the basic paradigm for action verbs (See Appendix A) story sets using the following combinations of stated and implied action verbs were constructed: carried - dropped, stood - jumped, held - threw, aimed - fired. (Appendix A).

The acquisition sequences for test forms using verbal materials were tape recorded to ensure consistency of presentation. Each recognition sentence was printed on a separate card. Pictures corresponding to the sentences were constructed by tracing each object from master drawings to ensure identity of objects across pictures. All pictures were then photocopied and set on 16 X 12 $\frac{1}{2}$ cm. plastic covered mounts for ease of handling. (For examples see Appendix A).

Sampling and Subjects - A preliminary power analysis (cf. Cohen, 1969) was used to estimate the minimum sample size necessary to establish whether any effect operating would have a reasonable chance of being detected by the experimental technique. Results of the power analysis (Appendix B) indicated that 4 groups of 10 subjects would have the following power: There would be an excellent chance of detecting a large main effect for the recognition test and a good chance for a medium effect. There was also a very good chance of detecting a large main effect for both modalities and relational terms. For the interactions (modalities X recognition test, relational terms X recognition test) there was an excellent chance of detecting a large effect but for other interactions the chance of detecting even a large effect was only moderate.

On the basis of this analysis it was decided to proceed with an overall sample of 40 subjects; 20 boys and 20 girls ranging in age from 9 years 9 months to 10 years 11 months were selected from standard 3 and 4 classes at a city contributing school. Age and sex of subjects and I.Q. scores were obtained from school records (I.Q. scores - Otis Intermediate Form A administered May 1975). Children for whom no I.Q. scores were available and those diagnosed as having serious reading disability were deleted from the list. The remainder were assigned randomly to 4 groups with a provision for equal sex distribution within each group (See Table 1).

TABLE 1

Means and Standard Deviations for Age and I.Q. Score for Four Groups of Subjects Assigned to Each Form of the Test.

Test Form	Group			
	1	2	3	4
	Pictorial Spatial	Verbal Spatial	Pictorial Action	Verbal Action
Mean Age	10yrs 3mths	10yrs 5mths	10yrs 4mths	10yrs 3mths
S.D. Age	4.4 mths	6.3 mths	5.4 mths	7.1 mths
Mean I.Q.	105	104	104	103
S.D. I.Q.	10.7	11.4	9.8	10.8

Procedure - Testing was carried out over a three week period during October - November 1975. Each subject was tested individually in a small interview room. A practice acquisition set was given to each subject initially to familiarise him with the procedure. The subject was then asked the following question. "Could you tell me something about what you have just heard (seen)?" This question was an open-ended one in order to minimise the possibility of disclosing the aim of the experiment. The experimental procedure included an acquisition phase and a recognition phase. Five story sets were presented for acquisition. One of these was included to minimise recency effects and was not tested on recognition. Verbal acquisition sentences were presented on tape with a 7 second pause between story sets. Acquisition pictures were exposed sequentially for 5 seconds each with a 7 second pause between story sets. Two orders of presentation of acquisition items were used. For each group subjects 1 - 5 received the acquisition sequence story sets 1, 2, 3, 4. For subjects 6 - 10 this order was reversed. All subjects were given the recency control set last.

Confidence ratings were used in testing for recognition. The three confidence levels were, 'CERTAIN', 'FAIRLY CERTAIN', 'UNCERTAIN'. A short practice on the use of confidence ratings was given to each subject between the acquisition and recognition phases as it was expected that primary school children would be unfamiliar with this procedure. For each of two recognition items (one originally presented in the practice set and one new item) subjects were initially required to answer either 'YES' or 'NO' in response to the question, "Have you heard (seen) this exact sentence (picture) before?" and then to indicate by pointing to the rating card placed beside them, which of the three levels of confidence they placed in their judgment.

The recognition phase of the experiment followed the practice for confidence ratings. Recognition items were presented in story blocks. Every subject within each group was given a different recognition order for story sets, and a different order of recognition items within story sets. Recognition items were ordered by use of a Latin Square technique and combined with a random ordering of story sets so that there were 10 different recognition sequences which were used in each of the 4 test forms. Lags between acquisition and recognition for story sets were equalised as closely as numbers allowed, the range being 3 - 5 lags for each story. Sentences were presented orally and simultaneously a card on which the sentence was printed was given to the subject. Recognition pictures were presented sequentially. For both sentences and pictures subjects were asked to indicate whether they had heard/seen that exact sentence/picture before and to give a confidence rating to their judgment. (For verbatim instructions see Appendix A).

RESULTS

In order to describe performance on the recognition test YES responses only were analysed. Raw frequencies were summed across subjects and across story sets for each form of the test and converted to percentages.

In the subsequent discussion A responses (OLD. True Premise) and B responses (NEW. Permissible Inference) will be referred to as situation preserving responses; C responses (NEW. False Premise) and D responses (NEW. Non permissible Inference) as situation distorting responses.

TABLE 2

Percentage of Total Recognition Responses Given to Each of the Four Types of Recognition Item.

Item Type	Recognition Responses			
	A. (T.P.) %	B (P.I.) %	C (F.P.) %	D (N.I.) %
Bransford et al. (1972)	42	29	16	13
All Test Forms	48.09	37.28	8.71	5.92
Pictorial Material	52.18	35.15	6.52	5.97
Verbal Material	44.29	38.93	10.74	6.04
Spatial Terms	46.93	36.73	10.88	5.44
Action Verbs	49.28	37.86	6.43	6.43

The percentage of YES responses given to each of the recognition items and summed across all forms of the test are given in Table 2. (For raw frequencies see Appendix C). The results obtained by Bransford et al. (1972) are included for comparison. In this experiment situation preserving responses accounted for 85% of the total recognition responses given in comparison with 71% obtained by Bransford et al. The highest recognition score (48%) was given to A responses (OLDS) indicating that subjects had a strong tendency to remember something of the surface form in which items were originally

presented. Situation preserving NEW items were chosen more often (B responses, 37%) than situation distorting NEW items combined (C and D responses, 15%). Table 2 also shows an analysis of results for each type of modality (pictorial and verbal) and for each type of relational term (spatial and action). Situation preserving responses ranged from 82% to 87% of the total recognition responses given. The highest recognition score for OLD items (A responses) was given to those presented in the pictorial modality (52%) compared with 44% given to those presented in the verbal modality. This result is in accordance with the prediction made that surface memory for pictorial material would be more accurate than for verbal material. For spatial terms and action verbs the recognition scores given for OLD items were virtually identical.

TABLE 3

Percentage of Total Recognition Responses Given to Each of the Four Types of Recognition Item for Specific Combinations of Modality and Relational Term.

Item Type	Recognition Responses			
	A (T.P.) %	B (P.I.) %	C (F.P.) %	D (N.I.) %
Pictorial Spatial	48.65	39.19	8.11	4.05
Pictorial Action	56.25	31.25	4.69	7.81
Verbal Spatial	45.20	34.25	13.70	6.85
Verbal Action	43.42	43.42	7.90	5.26

Table 3 shows the distribution of recognition responses for specific combinations of modality and relational term. In the pictorial forms of the test confusion of NEW situation preserving inferences (B responses) with OLD items (A responses) was more marked for spatial terms (A, 48%; B, 39%) than it was for action verbs (A, 56%; B, 31%). For the verbal forms of the test confusion of NEW situation preserving inferences

(B responses) with OLD items (A responses) was greater for action verbs (A, 43%; B, 43%) than it was for spatial terms (A, 45%; B, 34%). This pattern of responses is in accordance with the predictions made in the subsidiary hypothesis. The assumption that the pictorial modality is better adapted to conveying spatial information, whereas the verbal modality is more suited to conveying information about action sequences is given some support by this result.

An analysis of variance (for summary see Appendix D) showed a significant main effect for the recognition test, $F(3,108) = 198.33$, $p < .001$. Main effects for modality and for relational term were non-significant. There was also a significant interaction between modality and relational term and recognition test, $F(3,108) = 4.70$, $p < .01$. No other interactions reached significance.

As it seemed clear from Tables 2 and 3 that subjects experienced little difficulty in separating situation preserving recognition items from situation distorting ones, a further analysis of variance was carried out on situation preserving items only. (For summary see Appendix D). This analysis was carried out to establish whether recognition memory for OLD items (recognition of A) was significantly stronger than it was for situation preserving NEW items (recognition of B). A significant main effect for the recognition test was obtained, $F(1,36) = 30.77$, $p < .01$ indicating that memory for the surface form in which items were originally presented was significantly stronger than was memory for situation preserving inferences. A significant interaction was again obtained between modality and relational term and recognition test, $F(1,36) = 9.25$, $p < .01$. The interactions between modality and recognition test, $F(1,36) = 7.20$, $p < .05$ and between modality and relational term, $F(1,36) = 5.79$, $p < .05$ were also significant in this analysis.

The interaction between modality and relational term (Figure 1) shows that these variables are not completely independent from one another. When items were presented in the verbal modality a higher recognition score was given to action verbs than to spatial terms. For items presented in the pictorial modality action verbs were given a lower recognition score than were spatial terms. The difference

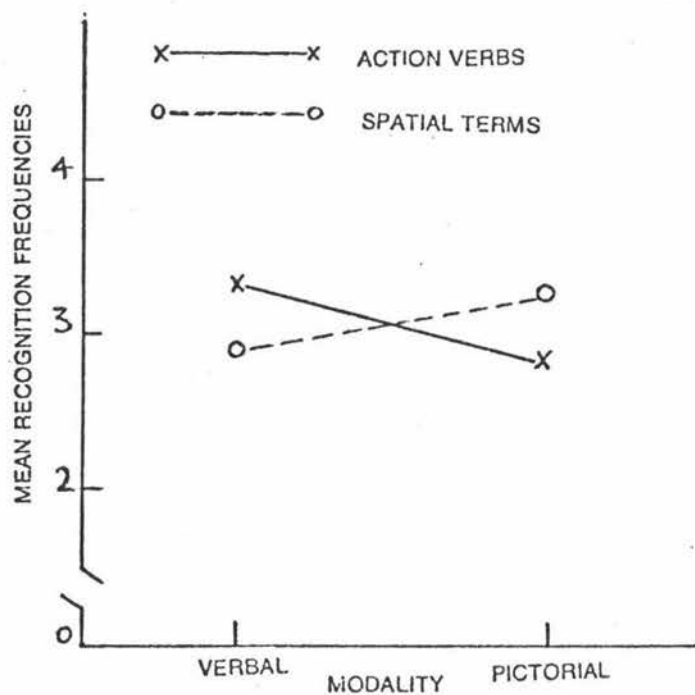

Figure 1. The Interaction Between Modality and Relational Term for A and B Recognition Items.

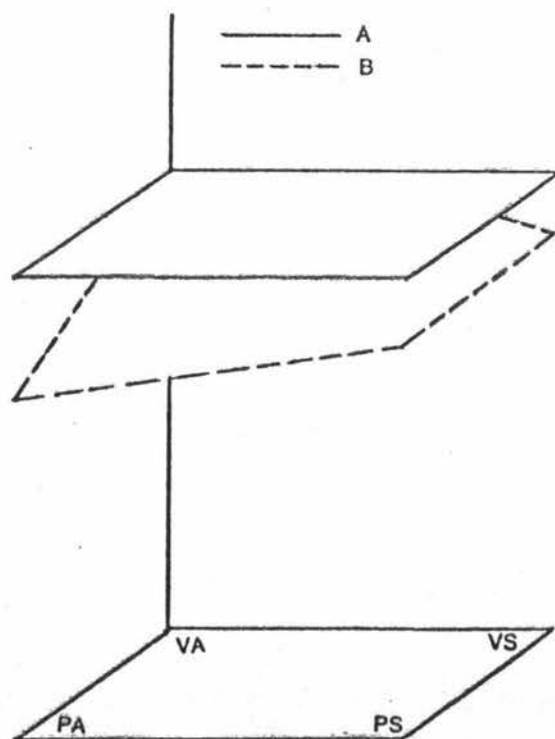

Figure 2. Representation of the Interaction Modality X Relational Term X Recognition Test for A and B Recognition Items. (VA = Verbal Action, VS = Verbal Spatial, PA = Pictorial Action, PS = Pictorial Spatial).

between the mean frequencies of recognition responses given to action verbs and spatial terms in each of the two modalities can be wholly attributed to differences in the responses given to situation preserving NEW items (B items). In both the pictorial and the verbal modalities recognition responses given to OLD items were identical for both spatial terms and action verbs (See Appendix C). If the generation and integration of situation preserving inferences can be taken as some evidence that a schema of the overall situation has been formed, then this result gives support to the view that the verbal modality facilitates the formation of schema about action sequences more readily than it does the formation of schema about spatial relationships; conversely, the pictorial modality facilitates schema formation about spatial relationships more readily than it does schema formation about action sequences.

The interaction between modality, relational term and recognition test is illustrated in Figure 2. NEW situation preserving responses (B responses) were confused with OLD items (A responses) most frequently when action verbs were presented in the verbal modality and least frequently when action verbs were presented in the pictorial modality. For spatial terms the degree of confusion was very similar for both modalities.

Confidence ratings were analysed separately from yes no responses. As there was some doubt as to whether subjects had mastered the technique of using confidence ratings during the practice sessions a proportional analysis of conditional probabilities was carried out on their ratings. The proportion of items rated at each level of confidence was considered as a function of whether they were OLD items. The results of this analysis are shown in Table 4. (For raw frequencies see Appendix E).

TABLE 4

Proportional Analysis of Conditional Probabilities for Confidence Judgments

Item Type			Confidence Judgments					
			---	--	-	+	++	+++
A	TP	OLD	.04	.08	.12	.17	.27	.57
B	PI	NEW	.13	.16	.28	.33	.57	.31
C	FP	NEW	.41	.37	.30	.25	.06	.08
D	NI	NEW	.42	.39	.30	.25	.10	.04

Note - Results would approximate those found in more conventional Old-New recognition tasks if A and B responses and C and D responses are combined.

Although responses were summed across subjects this analysis gives some indication that subjects were in general using confidence judgments sensibly and sensitively. Situation preserving inferences (B responses) although actually NEW items were generally treated as OLD items in terms of the proportion of 'yes' responses given at each confidence level. However the reversal of the expected proportions of judgments given at the two highest confidence levels ($++ = .57$; $+++ = .31$) indicates that subjects had some reservation about making certainty judgments at the very highest level of confidence for these responses.

TABLE 5

Cumulated Proportions of Confidence Judgments Cut Off at Five Confidence Levels.

Item Type			Confidence Judgments				
			---/--	--/-	-/+	+/**	**/**
A	TP	OLD	.93	.88	.86	.85	.73
B	PI	NEW	.81	.72	.66	.64	.40
C	FP	NEW	.44	.21	.15	.13	.11
D	NI	NEW	.40	.16	.10	.08	.04

Confidence judgments were also used to provide a more extended evaluation of the results than was possible by analysis of 'YES' responses only. The cumulated proportions of confidence judgments given to each type of recognition item were calculated at each of the five cut off points. The proportions were obtained by cumulating the raw frequencies (Appendix E) from right to left as is conventional (cf. Murdock, 1974, pp.27-28) and converting these, at each cut off point, to a proportion of the total number of times each item was tested. The pattern of results $A > B > C > D$ obtained at the YES/NO cut off point was also found at all other cut off points. Furthermore B was found to be closer to A than to either C or D at every cut off point except at the ++/+++ level. It is clear that the conclusions reached on the basis of the analysis of 'YES' responses only are not dependent upon the selection of that particular cut off point but hold across the range of confidence levels, the only divergence being some hesitancy to use the +++ confidence level for B type items.

DISCUSSION

The predictions made in the main hypothesis are supported by the results of this experiment which suggest that the process of constructing and integrating inferential information into memory representations is not confined to sentence memory only (Bransford et al., 1972; Sachs, 1967), but is part of a more general process of knowledge acquisition (Barclay, 1973). That is, the inference process was found to operate when information was originally presented in either verbal or pictorial form and independently from the type of relationships portrayed in the original explicit description of a situation or event. On all forms of the recognition test subjects tended, in general, to treat NEW inference based recognition items which preserved the meaning of the relationships portrayed in the original description as OLD items, but to reject those NEW items which violated these relationships. These results give support to the growing body of experimental evidence (e.g. Baggett, 1975; Bransford et al., 1972; Moser, 1976) which shows that when related premises are presented as a single meaningful unit subjects are able to retrieve inferential information almost as easily as they are able to retrieve explicitly memorised material.

The high recognition score given to situation preserving inferences does seem to provide evidence that subjects integrated the original premises into an overall schema of the total situation or event portrayed. However the question of whether the pattern of responses given to NEW items could be due to response bias or to random error needs to be considered. Only one proposition at a time was presented to the subjects in the recognition sequence. As the experimental design allowed that every subject within each group was given a different order of recognition items for each story set a response bias based on order of presentation was not possible. A random error pattern based on a .5 probability level would be expected to result in a similar number of recognition responses for each NEW recognition item. This was not the case. When results for all forms of the recognition test were combined, situation preserving NEW items were chosen almost three times as often as situation distorting NEW items combined.

Moser (1976) has suggested that an inference measure provides the best indicator of whether or not integration of related premises has taken place. The inference process is concerned not only with discrete or combined units of information explicitly presented to subjects (Bransford and Franks, 1971), but with a unified holistic description of the total event in context (Jenkins, 1974). In constructing inferences subjects need to integrate into their memory representations of the overall event extra-stimulus information based on prior knowledge and experience to the extent that this information renders the schema of the overall event, rather than the explicit premises, more meaningful.

In this experiment, memory for the surface form in which items were originally presented was found to be significantly stronger than was inferential memory. This surface memory strength did not, however, eliminate the integration of inferences into memory schema as may have been expected from the results of research on the role of instructions in this type of experiment. (Barclay, 1973; Katz, 1973; White, 1974). For example, Barclay (1973) found that subjects who were asked to construct a representation of an overall array were poorer at recognizing the exact sentences presented in acquisition than were those subjects who were required to memorise the acquisition sentences as discrete entities. On the basis of this research Moser (1976) has suggested that those subjects who do make inferences may also tend to make the greatest number of recognition errors for OLD items. The data from this experiment do not support this view. An inspection of the results for individual subjects (Appendix F) shows that in all but three cases those subjects who gave a large number of recognition responses to inference based situation preserving NEW items, also gave an equal or a higher number of recognition responses to OLD items. This finding is consistent with an interpretation of the results which suggests that, in general, subjects integrated the original premises into a schema of the overall event portrayed. Selected elements of the original premises could be expected to provide essential components of such an overall schema; therefore the high number of recognition responses given to both OLD items and inference based NEW situation preserving items by the same subjects seems to provide support for the view that schema formation did take place.

The analysis of confidence ratings did indicate that subjects were more cautious in placing the highest level of confidence in their recognition responses to situation preserving NEW items than they were for responses that were actually OLD; inferences that clearly violated the meaning relationships outlined in the original premises, however, were readily rejected by them. The construction of inferences is based on probability rather than certainty. Even in the case of spatial relationships which involve inferences based on logical necessity it is possible that more than one set of logically consistent inferences can be derived from the same set of interrelated premises. This probability element might well account for the decrease in certainty judgments given recognition responses to situation preserving inferences at the very highest confidence level. That is, subjects who integrated these inferences into their own schema of the overall situation were prepared to place a reasonable degree of confidence in their recognition responses to them. They did not have for these items, however, the surface memory cues in addition to the schema to confirm their judgments at the highest confidence level, as was the case for OLD items.

The analysis of results for each type of modality shows that essentially the same pattern of responses was given when the original propositions were presented to subjects in the pictorial modality as was given when the verbal modality was used for presentation of the propositions. When related pictures are presented as a meaningful sequence the pictures do not seem to be treated as isolated or static events but rather as integrated aspects of a memory representation of the overall situation or event portrayed. In this experiment the semantic integration phenomena, which have been found to operate in experiments using verbal materials (Barclay, 1973; Bransford and Franks, 1971; Bransford *et al.*, 1972) did generalise to the pictorial modality also. Brown (1976) who approached this question by using a different experimental technique has also found evidence to support the view that the semantic integration phenomena operate in the pictorial modality.

A comparison of the results obtained for the pictorial and the verbal modalities shows, however, that although the general pattern of results was similar for each modality the recognition score for OLD items was considerably higher for those presented in the pictorial modality than it was for OLD items presented in the verbal modality. This finding is in accordance with the prediction made in the main hypothesis that surface memory for pictures would be more accurate than it would be for verbal material (Baggett, 1975; Shepard, 1967). This greater strength of surface memory for pictures did not influence, to any marked degree, the proportion of recognition responses given to NEW situation preserving inferences in the pictorial modality. That is, when the results for the two types of relational term were combined for each modality the proportion of recognition responses given to situation preserving inferences in the pictorial and the verbal modalities was very similar. However when the results for each of the two modalities were analysed separately for spatial terms and for action verbs there were very marked differences in the number of recognition responses given to situation preserving inferences in the different combinations of modality and relational term. Although the inference process did, in general, operate when the original propositions were presented in either verbal or pictorial form this interaction effect indicated that there was a degree of variation in this process within each modality depending upon the type of relational term used.

The inclusion of two types of relational term in this experiment was suggested by Clark's (1973) paper on Language - as - Fixed - Effect - Fallacy. Although the major thrust of this paper is concerned with the inadequacies of statistical procedures which treat sample items, in research involving linguistic materials, as a fixed rather than a random effect and with statistical methods to overcome this problem, Clark did not advocate that attempts to broaden the empirical basis of this type of research should consequently be abandoned. Rather he suggested that investigators should be as explicit as possible about the constraints they were trying to conform to and increasingly refine the procedures for specifying the language populations they were using. Nevertheless when the results for

spatial terms were combined for the two modalities and compared with the results for action verbs combined for the two modalities there was very little difference between them in the proportion of responses given to each of the four recognition items. As the main effect for relational term did not reach significance in either the four item or the two item analysis this result could be interpreted as an indication that the process of generating and integrating inferences into memory schema is not affected by the type of relational term used in the original premises. This is a reasonably accurate reflection of the pattern of responses given to spatial terms in each of the two modalities, pictorial and verbal. For action verbs, however, the number of recognition responses given to situation preserving inferences were very similar to the number given to spatial terms when combined across modalities, but very different when evaluated separately for each modality. Action verbs, as a relational term, seem to be more sensitive to the effects of different modalities than do spatial terms.

This was illustrated by the interaction effect between modality and relational term which reached significance in the analysis of situation preserving items only. This result provides one of the most interesting findings of this experiment and gives some confirmation to the predictions made in the subsidiary hypothesis. This hypothesis was included mainly as an exploratory one as only minor theoretical attention (Neisser, 1972; Paivio, 1970) and little empirical research (Werner and Kaplan, 1973) has been concerned with the distinction contained in it. This hypothesis predicted that the confusion of situation preserving inferences with explicitly stated information would be more marked when spatial relationships in contrast to action sequences were portrayed in the verbal modality, and when action sequences in contrast to spatial relationships were portrayed in the verbal modality. The results of this analysis showed that a higher mean recognition score for OLD and NEW situation preserving items was given to action verbs presented to subjects in the verbal modality than was given to spatial terms presented in this modality. For items presented in the pictorial modality action verbs were given

a lower mean recognition score for OLD and NEW situation preserving items than were spatial terms. This result merits cautious interpretation because the interaction reached significance only on the re-analysis of the results of the original experiment. Nevertheless this finding does seem to imply that further research in this little explored area is indicated and for this reason it warrants discussion. The difference between the mean frequencies of situation preserving recognition responses given to action verbs and spatial terms in each of the two modalities is wholly attributable to differences in response given to NEW situation preserving items. In each of the two modalities recognition responses given to OLD items were identical for action verbs and for spatial terms. If an inference measure is taken to be a good indication of whether integration of related premises has taken place (Moser, 1976) then on the basis of this result it seems that the verbal modality facilitates the formation of an integrated schema derived from action sequences more readily than it does a schema about spatial relationships; conversely, the pictorial modality seems to facilitate schema formation about spatial relationships more readily than it does schema formation about action sequences.

Although there has been little empirical research on this question this result was to some extent predictable on theoretical grounds. That is, action sequences involve a temporal dimension which includes the relationship between concepts of the past, the present and the future. The verbal modality is structured to convey information about temporal sequences with some refinement through changes in the tense of verbs, the use of temporal comparatives such as 'before' and 'after' and the use of different syntactic forms. The pictorial modality is not well adapted for this. Werner and Kaplan (1973) have stated that, in the pictorial modality "To allude to temporal locus one must ... depict an occurrent actual event on state of affairs; one must refer to the past and the future under the guise of the present (p.434)."⁴¹ However a temporal dimension can be inferred by the viewer when a set of related pictures is presented in an ordered sequence, or on the basis of the probability with which one depicted action is likely to have preceded another. Findings from related

research (e.g. Baggett, 1975; Brown, 1976; Moser, 1976) suggest that, given the appropriate experimental conditions, subjects do derive inferences from information about action sequences presented in the pictorial modality and integrate them into memory schema. The present study is, however, the only one available in which recognition responses for inferences derived from pictorial material can be directly compared with those derived from verbal material. The results suggest that when action sequences are used as the relational term in an ordered set of propositions they are particularly sensitive to modality effects. That is, the generation and integration of inferences into a memory representation of an overall event seems to be facilitated when the verbal modality is used to present this type of relational term and attenuated when the pictorial modality is used.

A similar indication is given by the effect of the triple interaction between modality, relational term and recognition test which reached significance on both statistical analyses. That is, when action sequences were presented in the verbal modality there was a very marked tendency for subjects to integrate inferential information into their memory representations of the situation. The number of recognition responses given to NEW situation preserving inferences was, in fact, equal to the number of recognition responses given to OLD items. When action sequences were presented in the pictorial modality, however, the tendency to integrate inferential information into memory representations was very much reduced. The largest discrepancy between recognition responses given to NEW situation preserving inferences and those given to OLD items was obtained when action sequences were presented in the pictorial modality.

This interpretation of the results obtained for specific combinations of modality and relational term is tentative only. Additional research specifically designed to test the subsidiary hypothesis is clearly necessary in order to confirm it satisfactorily.

Although the problem of defining the referents of the concept of 'abstraction' as it has been applied to schema theory was a background aim of this experiment and not directly investigated it may be given some clarification in terms of the results. Ten year old children, who would not be expected, according to Piaget (1954) and

Vygotsky (1962) to have attained the level of formal operational thought, did construct and integrate a memory schema of the overall situation that was portrayed in the original set of premises in this experiment. The capacity for abstract thought, however, does not seem to be, on either theoretical or empirical grounds (Reid, 1974), a necessary prerequisite for the abstraction of schema from environmental stimuli. The traditional psychological theory of concept development also makes use of the concept of 'abstraction' but in such a way that it refers not only to the formation of abstract concepts but also to the formation of concrete concepts. In the traditional theory the term 'abstraction' is used to refer to the abstraction of features or attributes that are common to a number of particular stimuli. Bolton (1972) describes this process.

"Not only must we notice similarities to form a general idea but we must also set aside particular differences which are not relevant to the concept in question. The former corresponds to what we call generalisation, the latter to discrimination p.100."

Neither the Piagetian nor the traditional view of the concept of 'abstraction' seems to adequately characterise the pattern of responses given by subjects in this experiment. That is, it does not seem possible to attribute the high number of recognition responses given to situation preserving inferences to either the process of discriminating features or attributes of the original stimuli, or to the generalisation of discriminated attributes of these stimuli to other instances. In all forms of the recognition test, but in particular in those that used action verbs as the relational term, the situation preserving inferences in contrast to other NEW items such as those based on false premises did not consist of features identical to those presented in the original premises. Rather, they consisted of entirely new information based on implied logically necessary or empirically probable relationships between these features.

The abstraction of common features from a described or perceived situation serves to group individual features of the objects or actors participating in it into categories definable on the inherent features of these participants (Strawson, 1959). Relationships between the participants in an overall situation or event are not, however, inherent qualities or features of the objects or actors themselves but can articulate and integrate very diverse participants into an overall memory representation of the situation. The former description corresponds to the traditional theory of concept development; the latter, which has received recent attention in research on concept acquisition (Nelson, 1974) corresponds to the theory, advanced by Cassirer (1923/1973), that a concept can best be characterised by its logical (functional) relationships rather than in terms of common features.

These two views parallel the paradigmatic-syntagmatic distinction advanced by Jakobson (Jakobson and Halle, 1956). Research on the abstraction of schema based on the common properties of sets of stimuli as was illustrated by Evans (1967a, 1967b) and Posner and Keele (1968, 1969) characterises the paradigmatic pole of this distinction; experimental studies in which inferential information was abstracted from the original premises by subjects and integrated into an overall schema of the situation (Baggett, 1975; Bransford *et al*, 1972; Moser, 1976), characterise the syntagmatic pole of this distinction.

It is clear that neither the traditional theory nor the view advanced by Cassirer are individually sufficient to conceptualise the processes operative in the abstraction of schema from stimulus materials; Bartlett's (1932) notion of an abstract 'schema' is a concept superordinate to both theoretical positions. As Pylyshyn (1973) has pointed out, to refer to a cognitive representation from sensory stimuli is to imply that sensory events are abstracted and interpreted into a set of concepts and relationships in order to be so represented. The research reviewed in this study indicates that 'what is abstracted' seems to depend, in the experimental situation, on very specific aspects of the input material such as the type of information conveyed, the organization of stimulus materials and the instructions given to subjects. The ability to manipulate these

variables and to relate them to different types of memory schema can provide important information about the nature of the memory system itself (Moser, 1976). The paradigmatic - syntagmatic distinction seems to be one useful way to clarify the referents of the concept of an abstract 'schema' as it has been applied in memory research, and to conceptualise the different types of memory schema derived from stimulus situations.

The present study has been concerned with the syntagmatic pole of this distinction. The experimental design used has allowed for a number of related questions to be investigated within the framework of a single experiment. This approach has had both advantages and disadvantages. The advantages concern the direct comparisons that have been possible due to the use of two modalities (pictorial and verbal) to present the same sets of basic propositions; in addition the two types of relational term investigated (action verbs and spatial terms) have allowed for further distinctions to be introduced into the analysis of results. Overall the findings suggest that the process of constructing and integrating inferential information into memory representations is not confined to sentence memory only, but operates also when stimulus information is presented in the pictorial modality. This interpretation is adequately supported by the results. The findings of this research also indicated that the variables of modality and relational term are not completely independent of one another but that the effects of one are partially dependent upon the level of another. The approach taken did not, however, allow for this result to be satisfactorily confirmed within the framework of the experimental design. An extension of the present study addressed to this question seems to be indicated.

REFERENCES

- Anderson, R.C., and Ortony, A. On putting apples into bottles: A problem in polysemy. Cognitive Psychology, 1975, 7, 167-180.
- Attaneave, F. How do you know? American Psychologist, 1974, 29, 7, 493-499.
- Baggett, P. Memory for explicit and implicit information in picture stories. Journal of Verbal Learning and Verbal Behaviour, 1975, 14, 538-548.
- Barclay, J.R. The role of comprehension in remembering sentences. Cognitive Psychology, 1973, 4, 229-254.
- Bartlett, F.C. Remembering: A study in experimental and social psychology. London: Cambridge University Press, 1932.
- Begg, I., and Paivio, A. Concreteness and imagery in sentence meaning. Journal of Verbal Learning and Verbal Behaviour, 1969, 8, 821-827.
- Bloom, L. Language development: Form and function in emerging grammars. Cambridge Ma.: M.I.T. Press, 1970.
- Bolton, N. The psychology of thinking. London: Methuen, 1972.
- Bransford, J.D., Barclay, J.R., and Franks, J.J. Sentence memory: A constructive versus interpretive approach. Cognitive Psychology, 1972, 3, 193-209.
- Bransford, J.D., and Franks, J.J. The abstraction of linguistic ideas. Cognitive Psychology, 1971, 2, 331-350.
- Brown, A.L. Semantic integration in childrens' reconstruction of narrative sequences. Cognitive Psychology, 1976, 8, 247-262.

- Carey, S. The syntactic and referential aspects of linguistic encoding. Unpublished honours thesis, Harvard University, 1964.
- Carpenter, P., and Just, M.A. Sentence comprehension: A psycholinguistic processing model of verification. Psychological Review, 1975, 82, 45-73.
- Cassirer, E. Structure and function of Einstein's theory of relativity. (Trans. W.C. Swaby and M.C. Swaby). New York: Dover Publications, 1973. (Original publication Chicago: Open Court Publications, 1923.)
- Chase, W.G., and Clark, H.H. Mental operations in the comparison of sentences and pictures. In Gregg, L.W. (Ed.) Cognition in learning and memory. New York: John Wiley and Sons Inc., 1972.
- Clark, H.H. The language-as Fixed-Effect Fallacy: A critique of language statistics in psychology. Journal of Verbal Learning and Verbal Behaviour, 1973, 12, 335-359.
- Clark, H.H., Carpenter, P., and Just, M.A. Visual processes in linguistic comprehension. In Chase, W.G. (Ed.) Visual information processing. Symposium on Cognition, 8th, Carnegie-Mellon University, 1972. New York: Academic Press, 1973.
- Clark, H.H., and Chase, W.G. On the process of comparing sentences against pictures. Cognitive Psychology, 1972, 3, 472-517.
- Clark, H.H., and Clark, E.V. Semantic distinctions and memory for complete sentences. Quarterly Journal of Experimental Psychology, 1969, 82, 545-553.
- Cohen, J. Statistical power analysis for the behavioural sciences. New York: Academic Press, 1969.
- Craik, F.I. A 'levels of analysis' view of memory. In Pliner, P., Knames, L., and Alloway, T.M. (eds.) Communication and affect: Language and thought. New York: Academic Press, 1973.

- Craik, F.I., and Lockhart, R.S. Levels of processing: A framework for memory research. Journal of Verbal Learning and Verbal Behaviour, 1972, 11, 671-684.
- Dawes, R.M. Memory and distortion of meaningful written material. British Journal of Psychology, 1966, 57, 77-86.
- Deese, J. Behaviour and fact. American Psychologist, 1969, 24, 515-522.
- Evans, S.H. A brief statement of schema theory. Psychonomic Science, 1967, 8, 87-88(a).
- Evans, S.H. Redundancy as a variable in pattern perception. Psychological Bulletin, 1967, 67, 104-113(b).
- Fillenbaum, S. Memory for gist: Some relevant variables. Language and Speech, 1966, 9, 217-227.
- Flores D'Arcais, G.B. Is there a memory for sentences? Acta Psychologica, 1974, 38, 33-58.
- Franks, J.J., and Bransford, J.D. Abstraction of visual patterns. Journal of Experimental Psychology, 1971, 90, 65-74.
- Franks, J.J., and Bransford, J.D. The acquisition of abstract ideas. Journal of Verbal Learning and Verbal Behaviour, 1972, 11, 311-315.
- Frederiksen, C.H. Effects of context induced processing operations on semantic information acquired from discourse. Cognitive Psychology, 1975, 7, 139-166.
- Frege, G. (1879). Geach, P., and Black, M. (eds.) Translations from the philosophical writings of Gottlob Frege. Oxford: Blackwell, 1960.
- Garner, W.R. To perceive is to know. American Psychologist, 1966, 21, 11-19.
- Gibson, E.J. Principles of perceptual learning and development. New York: Appleton-Century-Crofts, 1969.
- Green, D.W. The effects of task on the representation of sentences. Journal of Verbal Learning and Verbal Behaviour, 1975, 14, 275-283.

- Halliday, M.A.K. Notes on transitivity and theme. Journal of Linguistics, 1968, 4, 179-215.
- Head, H. Aphasia and kindred disorders of speech. Cambridge, England: Cambridge University Press, 1926.
- Huttenlocher, J., Eisenberg, K., and Strauss, S. Comprehension: Relation between perceived actor and logical subject. Journal of Verbal Learning and Verbal Behaviour, 1968, 7, 527-530.
- Huttenlocher, J., and Strauss, S. Comprehension and a statement's relation to the situation it describes. Journal of Verbal Learning and Verbal Behaviour, 1968, 7, 300-304.
- Jakobson, R., and Halle, M. Fundamentals of language. The Hague. Paris: Mouton, 1971.
- Jenkins, J.J. Remember that old theory of memory? Well, forget it! American Psychologist, 1974, 29, 11, 785-795.
- Katz, J.J. and Fodor, J. The structure of a semantic theory. In Fodor, J., and Katz, J.J. (eds.) The structure of language: Readings in the philosophy of language. Englewood Cliffs, New Jersey: Prentice-Hall, 1964.
- Katz, S. Role of instructions in abstraction of linguistic ideas. Journal of Experimental Psychology, 1973, 98, 79-84.
- Keenan, J., McKoon, L., and Kintsch, W. In Keenan, J. Memory for surface form. Unpublished manuscript, University of Colorado, 1975.
- Kintsch, W., and Monk, D. Storage of complex information in memory: Some implications of the speed with which inferences can be made. Journal of Experimental Psychology, 1972, 94, 25-32.
- Kuczajii, S.A. On the acquisition of a semantic system. Journal of Verbal Learning and Verbal Behaviour, 1975, 14, 340-458.
- Lamb, S.M. Outline of a stratification grammar. Washington D.C.: George Washington University Press, 1966.

- Luria, A.R. Two basic kinds of aphasic disorders. Lingua, 1973, 115, 57-66.
- MacNamara, J. Cognitive basis of language learning in infants. Psychological Review, 1972, 79, 1-13.
- Michotte, A. The perception of causality. London: Methuen and Co. Ltd., 1963.
- Miller, G.A. English verbs of motion: A case study in semantics and lexical memory. In Melton, A.W., and Martin, E. (eds) Coding Processes in human memory. Washington D.C.: Winston, 1972.
- Moser, S.D. Inferential reasoning in episodic memory. Journal of Verbal Learning and Verbal Behaviour, 1976, 15, 193-212.
- Murdock, B.B. Human memory: Theory and data. New York: John Wiley and Sons, 1974.
- Neisser, U. Cognitive Psychology. New York: Appleton-Century-Crofts, 1967.
- Neisser, U. Changing concepts of imagery. In Sheehan, P.W. (ed.) The function and nature of imagery. New York: Academic Press, 1972.
- Nelson, K. Concept, word and sentence: Interrelations in acquisition and development. Psychological Review, 1974, 81, 267-285.
- Olson, D.R., and Filby, N. On the comprehension of active and passive sentences. Cognitive Psychology, 1972, 3, 261-281.
- Paivio, A. On the functional significance of imagery. Psychological Bulletin, 1970, 73, 385-392.
- Piaget, J. The construction of reality in the child. (Translated M. Cook). New York: Basic Books, 1954.
- Posner, M.I. Abstraction and the process of recognition. In Bower, G.H., and Spence, J.T. (eds) The psychology of learning and motivation. New York: Academic Press, 1969.
- Posner, M.I. Cognition: An introduction. Glenview, Illinois: Scott, Foresman and Co. 1973.

- Posner, M.I., Goldsmith, R., and Welton, K.E. Perceived distance and the classification of distorted patterns. Journal of Experimental Psychology, 1967, 73, 28-38.
- Posner, M.I., and Keele, S.W. On the genesis of abstract ideas. Journal of Experimental Psychology, 1968, 77, 353-363.
- Posner, M.I., and Keele, S.W. Retention of abstract ideas. Unpublished experiments, University of Oregon, 1969.
- Posner, M.I. and Keele, S.W. Retention of abstract ideas. Journal of Experimental Psychology, 1970, 83, 304-308.
- Posner, M.I., and Konick, A.F. Short term retention of visual and kinesthetic information. Organization Behaviour and Human Performance, 1966, 1, 71-86.
- Pylyshyn, Z.W. What the mind's eye tells the mind's brain: A critique of mental imagery. Psychological Bulletin, 1973, 80, 1-24.
- Reid, L.S. Toward a grammar of the image. Psychological Bulletin, 1974, 81, 6, 319-334.
- Rosenberg, S., and Jarvella, R.J. Semantic integration and sentence perception. Journal of Verbal Learning and Verbal Behaviour, 1970, 9, 548-553.
- Sachs, J.S. Recognition memory for syntactic and semantic aspects of connected discourse. Perception and Psychophysics, 1967, 2, 437-442.
- Sassure, F. de, Course in general linguistics. 1916 (3rd ed.) New York: Philosophical Library, 1959.
- Schmidt, R.A. A schema theory of discrete motor skill learning. Psychological Review, 1975, 4, 225-260.
- Shepard, R.N. Recognition memory for words, sentences and pictures. Journal of Verbal Learning and Verbal Behaviour, 1967, 6, 156-163.

- Singer, M., and Rosenberg, S.T. The role of grammatical relations in the abstraction of linguistic ideas. Journal of Verbal Learning and Verbal Behaviour, 1973, 12, 273-284.
- Strawson, P.F. Individuals: An essay in descriptive metaphysics. London: Methuen, 1959.
- Tannenbaum, P.H., and Williams, F. Generation of active and passive sentences as a function of subject or object focus. Journal of Verbal Learning and Verbal Behaviour, 1968, 7, 246-250.
- Trabasso, T. Language and cognition. In Chase, W.G. (ed.) Visual information processing. Symposium on Cognition, 8th, Carnegie-Mellon University, 1972. New York: Academic Press, 1973.
- Vernon, M.D. The functions of schemata in perceiving. Psychological Review, 1955, 62, 180-191.
- Vygotsky, L.S. Thought and speech. New York: Wiley, 1962.
- Wason, P.C. The context of plausible denial. Journal of Verbal Learning and Verbal Behaviour, 1965, 2, 7-11.
- Wells, J.E. Some current trends in memory. The New Zealand Psychologist, 1973, 2, 52-56.
- Werner, H. and Kaplan, B. Symbol formation. New York: John Wiley and Sons Inc., 1963.
- White, K.G. Abstracting ideas from sentences. The New Zealand Psychologist, 1974, 2, 74-84.

APPENDIX A

MATERIALS

<u>Contents</u>	<u>Page</u>
<u>SPATIAL TERMS</u>	
Paradigm	65.
Story Sets	66.
<u>ACTION VERBS</u>	
Paradigm	68.
Story Sets	69.
<u>INSTRUCTIONS</u>	
Verbal Material	71.
<u>PICTORIAL MATERIALS</u>	
Spatial Terms	72.
Action Verbs	74.
<u>INSTRUCTIONS</u>	
Pictorial Materials	76.

SPATIAL TERMSParadigmAcquisition

- 1 A is (Relation x) to B.
- 2 C is related to A in a way that (logically) implies that C is (Relation x) to B.
- 3 Descriptive Filler.

Recognition

A	A - (Relation x) - B.	OLD	TP.
B	C - (Relation x) - B.	NEW	PI.
C	A - (Relation y) - B.	NEW	FP.
D	C - (Relation y) - B.	NEW	NI.

Abbreviations

- TP. - True Premise
 PI. - Permissible Inference
 FP. - False Premise
 NI. - Non-permissible Inference

Note - Relation x = Relationship stated in True Premise. e.g. 'above'.
 Relation y = The opposite of relation x. e.g. 'below'.

SPATIAL TERMSStory SetsStory Set 1

In front of - Behind

Acquisition

1. There is a girl standing in front of the pram.
2. A lamp post is beside the girl.
3. The girl's dress is pink.

Recognition

- A. There is a girl standing in front of the pram.
- B. There is a lamp post standing in front of the pram.
- C. There is a girl standing behind the pram.
- D. There is a lamp post standing behind the pram.

Story Set 2

Right - Left.

Acquisition

1. The box is to the right of the tree.
2. A chair is on top of the box.
3. The tree is green and tall.

Recognition

- A. The box is to the right of the tree.
- B. The chair is to the right of the tree.
- C. The box is to the left of the tree.
- D. The chair is to the left of the tree.

SPATIAL TERMSStory Sets (Cont.)Story Set 3

Above - Below.

Acquisition

1. On the shelves the apples are stored above the oranges.
2. There are some jugs beside the apples.
3. The jugs are blue.

Recognition

- A. On the shelves the apples are stored above the oranges.
- B. On the shelves the jugs are stored above the oranges.
- C. On the shelves the apples are stored below the oranges.
- D. On the shelves the jugs are stored below the oranges.

Story Set 4

Higher - Lower.

Acquisition

1. The kite is flying higher than the flag.
2. There is a balloon beside the kite.
3. The balloon is large and yellow.

Recognition

- A. The kite is flying higher than the flag.
- B. The balloon is flying higher than the flag.
- C. The kite is flying lower than the flag.
- D. The balloon is flying lower than the flag.

ACTION VERBSParadigmAcquisition

1. A does Action x.
2. B does Action y.
3. The conclusion implies that (probably)
A does Action z also.

Recognition

A	A does Action x.	OLD	TP.
B	A does Action z.	NEW	PI.
C	B does Action x.	NEW	FP.
D	B does Action z.	NEW	NI.

Abbreviations

- TP. - True Premise
 PI. - Permissible Inference
 FP. - False Premise
 NI. - Non-permissible Inference

ACTION VERBSStory SetsStory Set 1Acquisition

1. The dog carried a small basket.
2. A cat chased the dog.
3. The cat found the small basket.

Inference - The dog (probably) dropped the basket.

Recognition

- A. The dog carried a small basket.
- B. The dog dropped a small basket.
- C. The cat carried a small basket.
- D. The cat dropped a small basket.

Story Set 2Acquisition

1. The kitten stood on the box.
2. A girl put some milk on the floor.
3. The kitten drank the milk.

Inference - The kitten (probably) jumped off the box.

Recognition

- A. The kitten stood on the box.
- B. The kitten jumped off the box.
- C. The girl stood on the box.
- D. The girl jumped off the box.

ACTION VERBSStory Sets (Cont.)Story Set 3Acquisition

1. John held a large ball.
2. Sally took off her hat.
3. Sally caught the large ball in her hat.

Inference - John (probably) threw the large ball.

Recognition

- A. John held a large ball.
- B. John threw a large ball.
- C. Sally thre a large ball.
- D. Sally threw a large ball.

Story Set 4Acquisition

1. The man aimed the gun.
2. A boy held up the target.
3. The bullet hit the target.

Inference - The man (probably) fired the gun.

Recognition

- A. The man aimed the gun.
- B. The man fired the gun.
- C. The boy aimed the gun.
- D. The boy fired the gun.

INSTRUCTIONSVerbal Materials

"I am going to ask you to listen to some sets of sentences on the tape recorder. Each set of sentences tells you about a different story (scene). I would like you to listen very carefully to these stories because I am going to ask you some questions about them later. We will have a short practice before we start with the real experiment."

Practice Set (on tape). Question "Could you tell me something about what you have just heard?"

Acquisition Sequences (on tape). Subjects 1 - 5 stories 1, 2, 3, 4, Recency. Subjects 6 - 10 stories 4, 3, 2, 1, Recency.

Practice for Recognition and Confidence Ratings. "In the next part of the experiment I am going to ask you to listen to some more sentences. This time I will also give you a card that has printed on it the sentence I am saying. For each sentence I am going to ask 'Have you heard this exact sentence before?' If you have, answer 'Yes'. If you have not, answer 'No'. Then I will ask you how certain you are about whether you have or have not heard the exact sentence before. Point to the rating on this card that you want to choose. We will have a short practice on this before we go on to the next part."

Recognition Instructions. "I am now going to read you some more sentences. Some of the sentences in each set might be the same as the ones you have heard before. For these you answer 'yes'. Some of them might be different. For these you answer 'no'. There could be more than one sentence you have heard before in some of the sets."

PICTORIAL MATERIALS
SPATIAL TERMS Story Set 3
ACQUISITION

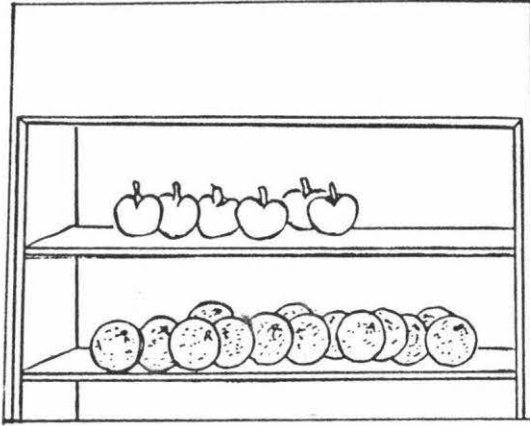

1

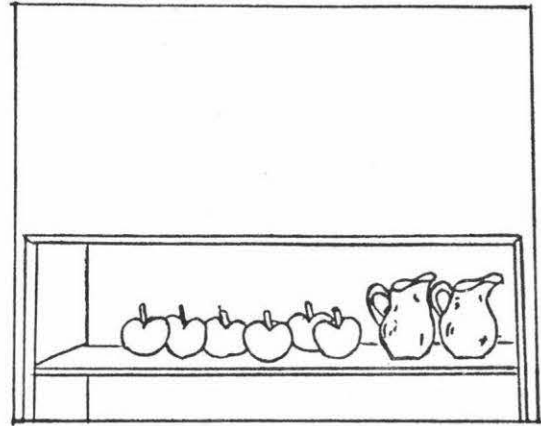

2

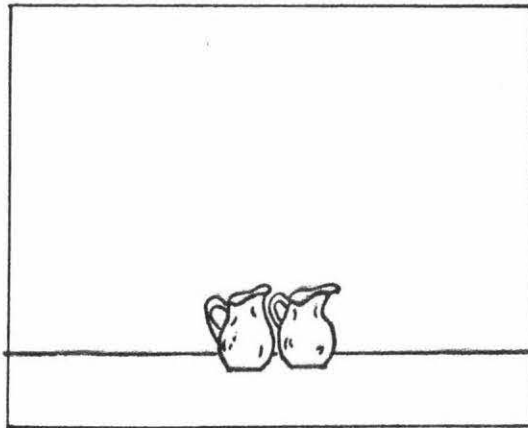

3

Note - In the original Acquisition Item 3 is coloured.

PICTORIAL MATERIALS
 SPATIAL TERMS Story Set 3
 RECOGNITION

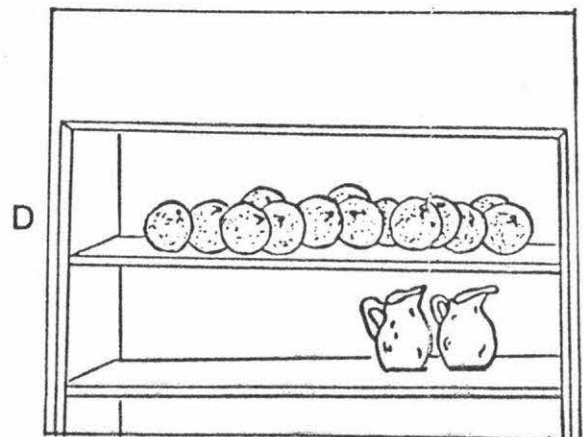
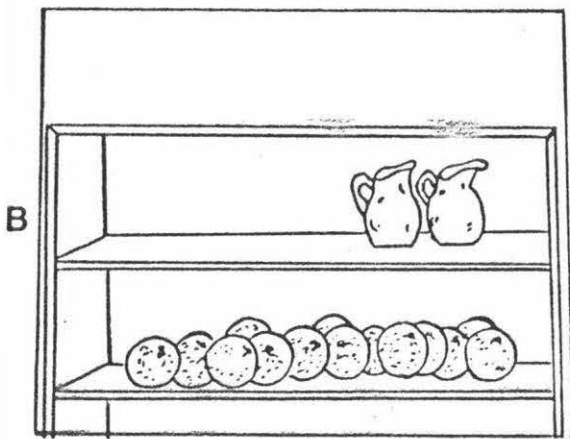
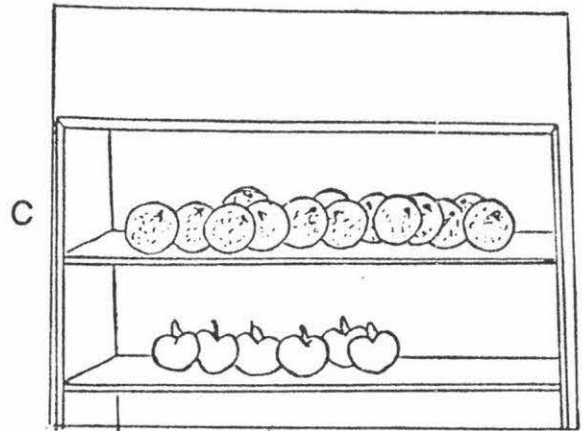
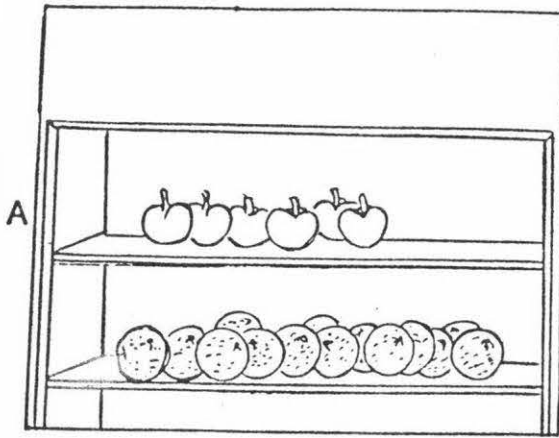

KEY

- A = True Premise
- B = Permissible Inference
- C = False Premise
- D = Non-Permissible Inference

PICTORIAL MATERIALS
ACTION VERBS Story Set 2
ACQUISITION

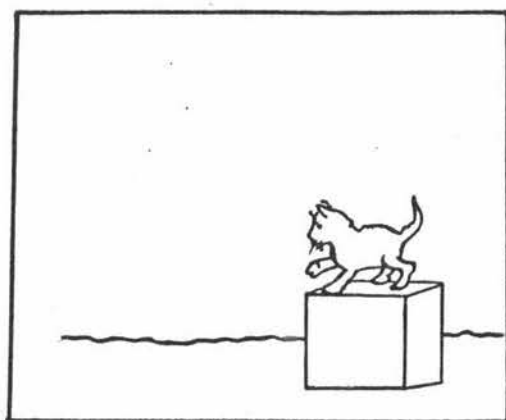

1

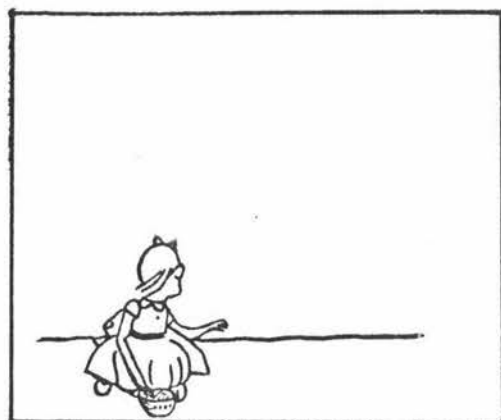

2

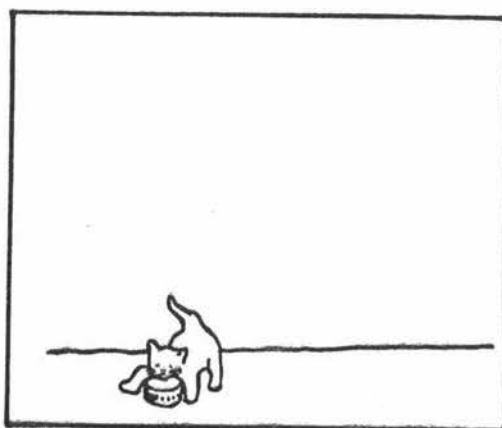

3

PICTORIAL MATERIALS
ACTION VERBS

Story Set 2

RECOGNITION

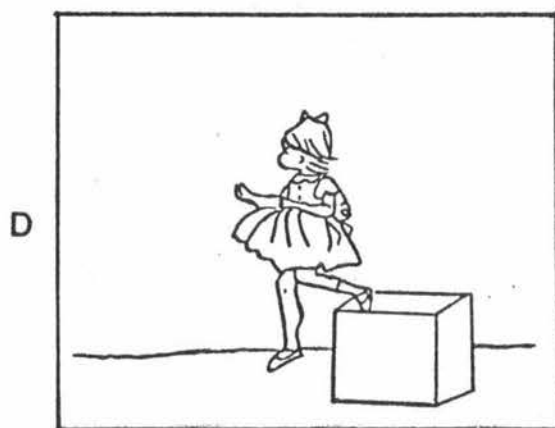
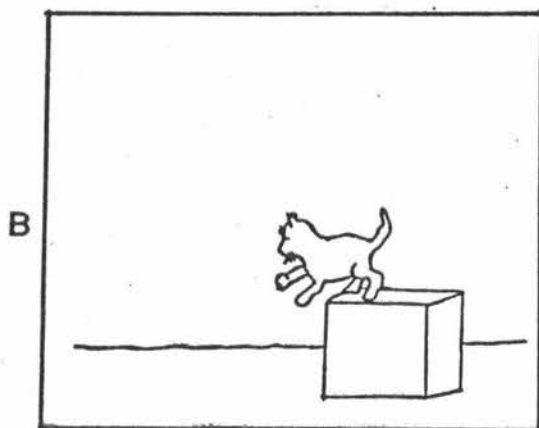
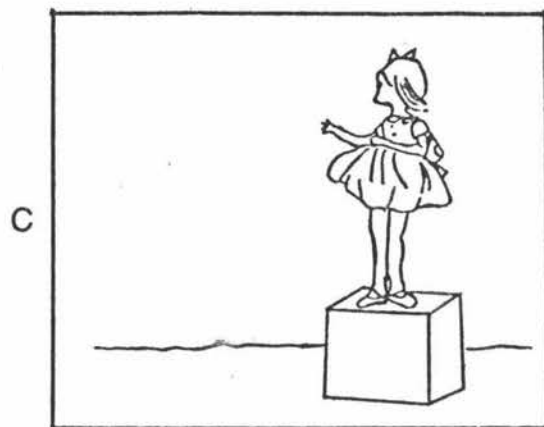
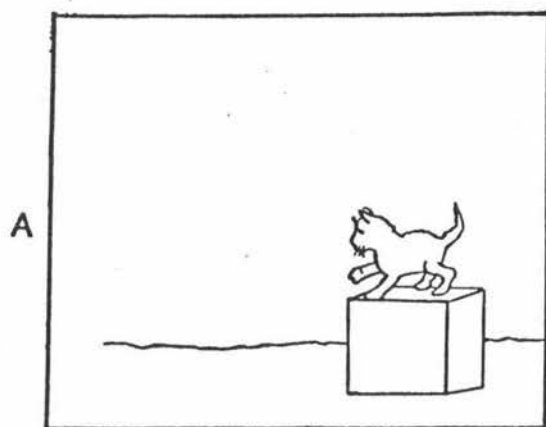

KEY

- A = True Premise
- B = Permissible Inference
- C = False Premise
- D = Non-Permissible Inference

INSTRUCTIONSPictorial Materials

"I am going to show you some sets of pictures. Each set of pictures tells you about a different story (scene). I would like you to look very carefully at these pictures because I am going to ask you some questions about them later. We will have a short practice before we start with the real experiment."

Practice Set. Question "Could you tell me something about what you saw?"

Acquisition Sequences. Subjects 1 - 5 stories 1, 2, 3, 4, Recency. Subjects 6 - 10 stories 4, 3, 2, 1, Recency.

Practice for Recognition and Confidence Ratings. "In the next part of the experiment I am going to show you some more pictures. For each picture I am going to ask 'Have you seen this exact picture before?' If you have answer 'Yes'. If you have not, answer 'no'. Then I will ask you how certain you are about whether you have seen or have not seen the exact picture before. Point to the rating on this card that you want to choose. We will have a short practice on this before we go on to the next part."

Recognition Instructions. "I am now going to show you some more pictures. Some of the pictures in each set might be the same as the ones you have seen before. For these you answer 'yes'. Some of them might be different. For these you answer 'no'. There could be more than one picture that you have seen before in some of the sets."

APPENDIX B

Power Analysis for Estimation of Sample Size (cf. Cohen, 1969).
Significance Criterion = .05

	Effect Size (f)	Power
<u>MAIN EFFECT FOR RECOGNITION TEST</u>	.10	.17
	.25	.81
	.50	.995
<u>MAIN EFFECTS</u>	.10	.09
Modality	.25	.34
Relational Term	.50	.88
<u>INTERACTIONS</u>	.10	.10
Modality X Recognition Test	.25	.47
Relational Term X Recognition Test	.50	.99
<u>INTERACTION</u>	.10	.07
Modality X Relational Term	.25	.18
	.50	.57
<u>INTERACTION</u>	.10	.07
Modality X Relational Term	.25	.21
X Recognition Test	.50	.72

Note - Cohen suggests that the following definitions of small, medium and large effects are arbitrary, but reasonable. Small effect, $f = .10$; Medium effect, $f = .25$; Large effect, $f = .50$.

APPENDIX C

Frequencies for Recognition Responses Given to Each of the Four
Types of Recognition Item

Item Type	Recognition Responses				Total
	A TP	B PI	C FP	D NI	
Pictorial Spatial	36	29	6	3	74
Pictorial Action	36	20	3	5	64
Verbal Spatial	33	25	10	5	73
Verbal Action	33	33	6	4	76
Totals	138	107	25	17	287

APPENDIX D

Summary of the Analysis of Variance for 'YES' Responses for Four Recognition Items(A B C D) on All Forms of the Recognition Test.

Source	df	MS	F	P
Modality	1	0.7562	1.527	
Relational Term	1	0.3062		
Modality X Relational Term	1	1.0562	2.133	
Recognition Test	3	90.1229	198.334	.001
Modality X Recognition Test	3	1.1395	2.507	
Relational Term X Recognition Test	3	0.3229		
Modality X Relational Term X Recognition Test	3	2.1395	4.708	.01

Summary of the Analysis of Variance for 'YES' Responses for Two Recognition Items (A B) on All Forms of the Recognition Test.

Source	df	MS	F	P
Modality	1	0.1125		
Relational Term	1	0.0125		
Modality X Relational Term	1	3.6125	5.79	.05
Recognition Test	1	12.0125	30.77	.01
Modality X Recognition Test	1	2.8125	7.20	.05
Relational Term X Recognition Test	1	0.0125		
Modality X Relational Term X Recognition Test	1	3.6125	9.25	.01

APPENDIX E

Frequencies for Confidence Judgments Given at Six Confidence Levels
for Four Types of Recognition Item

Item Type	Confidence Judgments					
	---	--	-	+	++	+++
A. TP OLD	10	8	4	2	18	118
B. PI NEW	29	15	9	4	39	64
C. FP NEW	89	36	10	3	4	18
D. NI NEW	95	38	10	3	7	7
Totals	223	97	33	12	68	207

Cumulated Frequencies of Confidence Judgments Cut Off at Five
Confidence Levels

Item Type	Confidence Judgments				
	---/--	--/-	-/+	+/**	**/**
A. TP OLD	150	142	138	136	118
B. PI NEW	131	116	107	103	64
C. FP NEW	71	35	25	22	18
D. NI NEW	65	27	17	14	7
Totals	417	320	287	275	207

APPENDIX F

Recognition Frequencies for Individual Subjects in Each of the Four
Forms of the Recognition Test

Test Form	Subject	Recognition Item			
		A	B	C	D
Verbal Action	1	4	4	0	0
	2	4	4	0	0
	3	3	3	1	1
	4	1	2	1	0
	5	4	4	1	1
	6	3	2	0	1
	7	3	4	1	0
	8	3	2	1	1
	9	4	4	0	0
	10	4	4	1	0
Verbal Spatial	1	4	2	0	0
	2	3	2	2	0
	3	3	3	2	0
	4	4	2	0	0
	5	3	3	1	1
	6	3	3	1	1
	7	4	1	0	2
	8	3	3	1	0
	9	3	2	1	0
	10	3	4	2	1

Recognition Frequencies for Individual Subjects in Each of the Four
Forms of the Recognition Test (Cont.)

Test Form	Subject	Recognition Item			
		A	B	C	D
Pictorial Action	1	4	2	1	0
	2	4	1	0	0
	3	4	2	0	0
	4	3	1	0	1
	5	3	2	0	0
	6	3	2	0	2
	7	4	3	1	1
	8	4	2	1	0
	9	4	3	0	1
	10	3	2	0	0
Pictorial Spatial	1	4	3	0	1
	2	3	3	0	0
	3	3	4	2	1
	4	4	3	0	0
	5	4	3	0	0
	6	4	3	0	0
	7	3	3	0	0
	8	4	2	1	0
	9	3	2	2	0
	10	4	3	1	1
