

Copyright is owned by the Author of the thesis. Permission is given for a copy to be downloaded by an individual for the purpose of research and private study only. The thesis may not be reproduced elsewhere without the permission of the Author.

**COMMUNITY OWNED AND OPERATED
RENEWABLE ENERGY SCHEMES IN
RURAL NEW ZEALAND**

A thesis presented in partial fulfilment of the requirements for
the degree of Master of Applied Science in Natural Resource
Management at Massey University, Palmerston North, New Zealand.

Glenn Irving

2000

Errata

The following references are missing from the reference list:

Frost, W. and Aspliden, C. (1994). Characteristics of the Wind. (in "Wind Turbine Technology", ed Spera, D.A.) *ASME Press*

Gipe, P. (1993). Wind Power for Home and Business : Renewable Energy for the 1990's and Beyond. *Post Mills, VT: Chelsea Green Publishing Co.*

Riordan, C. (1995). Solar Resource Characteristics. (in "Solar Cells and Their Applications", ed Partain LD), *John Wiley & Sons Inc, New York*

Shaw, et.al. (1996). Final Year Research Project, *Massey University*

Woods, A. et. al. (1997) Development and Demonstration of a Protocol for Community Owned and Operated Green Grid Remote Area Power Systems.

ABSTRACT

Due to the introduction of the Electricity Act (1992) and its later amendments, the future security of electricity supply to rural New Zealand is under question. Lines companies are legally obliged to maintain supply to existing customers until April 1st 2013, but can disconnect unprofitable customers after this date.

One option for rural customers is to establish their own community owned and operated renewable energy schemes. This study is the first step in identifying the engineering design, ownership, and environmental issues relating to this type of scheme.

Two case study sites – one in the North Island and one in the South Island – differed in their remoteness, population density and primary income sources.

Solar radiation and wind was measured at both sites. Power consumption data was also obtained from meters installed at the sites by Industrial Research Limited.

A review of legal ownership structures suitable for community owned electricity generation schemes was made and recommendations given from a New Zealand lawyer. Environmental issues associated with the development of electricity generating plants were identified, along with the implications of the Resource Management Act for renewable energy schemes.

A computer model was designed to assist a community in understanding the supply options available. It is based on present day costs of system components, and is designed to give maximum flexibility of design to the model user depending on resource availability.

For each site a number of options were identified and the costs of these options quantified. Comparisons were made between the options to identify the best for the site.

Acknowledgements

Although this thesis has been written by me, it has been contributed to by many. In order to unravel the complexities of a community owned renewable energy scheme I have had to work with people from many different sectors of society. There are far too many to name, so generalised acknowledgements will have to suffice.

First thanks goes to my wife, Lynn, for her unwavering support, and giving me the freedom to carry out a research project that involved so much travel.

To the team at Powerflow Ltd., for welcoming me into their company and providing me with some very valuable work experience. Thanks also for covering the costs of travel and equipment and for all the advice.

To my supervisors, Assoc. Prof. Ralph Sims and Dr. John Holland, for all their advice, time and expertise.

To Technology New Zealand, for the GRIF Scholarship that enabled me to work with Powerflow Ltd. on this project.

To the communities of Kumeroa, D'Urville Island, and Akitio for their hospitality and willingness to provide me with the information I required.

To God, who gave me the opportunity to work on a thesis that was enjoyable, challenging, rewarding and will hopefully be of use to many remote rural communities throughout New Zealand in the future.

“Coming together is a beginning
Keeping together is progress
Thinking together is unity
Working together is success”

Anonymous

Table of Contents

	Page
1 INTRODUCTION	1
<hr/>	
1.1 ELECTRICITY IN NEW ZEALAND TODAY	1
1.2 FACTORS INFLUENCING THIS STUDY	1
1.3 THE PRESENT ROLE OF RENEWABLE ENERGY SOURCES IN NEW ZEALAND	3
1.4 OBJECTIVES	4
1.5 SCOPE	5
1.6 REPORT STRUCTURE	6
2 DISTRIBUTED POWER SUPPLY SYSTEMS - LITERATURE REVIEW	8
<hr/>	
2.1 THE HISTORY OF RURAL ELECTRICITY RETICULATION IN NEW ZEALAND	8
2.1.1 THE PRESENT SITUATION	10
2.2 COMMUNITY OWNED RENEWABLE ENERGY SCHEMES	11
2.2.1 OVERSEAS EXPERIENCE	12
2.2.2 COMMUNITY STRENGTHENING	13
2.2.3 URBAN DRIFT	13
2.2.4 PROJECT OWNERSHIP AND LEADERSHIP	14
2.2.5 CONSULTATION	15
2.3 RELEVANT LAW	18
2.3.1 ELECTRICITY ACT 1992	18
2.3.2 ELECTRICITY INDUSTRY REFORM ACT 1998	18
2.3.3 RESOURCES MANAGEMENT ACT (RMA) 1991	19
2.4 RENEWABLE ENERGY - THE DESIGN PROCESS	21
2.4.1 DESIGN PROCESS OVERVIEW	21
2.4.2 LOADING PATTERNS	23
2.4.3 SOLAR ENERGY	25
2.4.4 WIND ENERGY	28
2.4.5 MICRO-HYDRO ENERGY	34
2.4.6 POWER MANAGEMENT - STORAGE, REGULATION AND INVERTING	38

3	CASE STUDY SITE DESCRIPTION	41
<hr/>		
	CASE STUDY COMMUNITY 1 – TOTARA VALLEY	41
3.1.1	REASONS FOR INCLUSION IN THE STUDY	41
3.1.2	LOCATION	41
3.1.3	PROPERTIES	42
	CASE STUDY COMMUNITY 2 – D'URVILLE ISLAND	43
3.2.1	REASONS FOR INCLUSION IN THE STUDY	43
3.2.2	LOCATION	44
3.2.3	TOPOGRAPHY AND GEOLOGY	45
3.2.4	POPULATION	45
3.2.5	EXISTING COMMUNITY STRUCTURE	45
3.3	CASE STUDY COMMUNITY 3 – AKITIO	46
3.3.1	REASONS FOR INCLUSION IN THE STUDY	46
3.3.2	TOPOGRAPHY	46
3.3.3	POPULATION	47
3.3.4	PROPERTIES	47
3.3.5	INCOME SOURCES	47
4	HOUSEHOLD QUESTIONNAIRE	48
<hr/>		
4.1	QUESTIONNAIRE SAMPLE	48
4.1.1	TOTARA VALLEY	48
4.1.2	D'URVILLE ISLAND	48
4.1.3	AKITIO	48
4.2	METHOD OF ADMINISTRATION	49
4.3	QUESTIONNAIRE DESIGN	49
4.4	PILOT QUESTIONNAIRE	50
4.5	FINAL QUESTIONNAIRE	51
4.5.1	TOTARA VALLEY	51
4.5.2	AKITIO	51
4.5.3	D'URVILLE ISLAND	51
4.5.4	SURVEY RESPONSE RATE	52
4.6	RESULTS AND DISCUSSION	53
4.6.1	TOTARA VALLEY	53
4.6.2	D'URVILLE ISLAND	59
4.6.3	AKITIO	65

4.6.4	SUMMARY	71
5	LEGAL OWNERSHIP	72
<hr/>		
5.1	LEGAL STRUCTURES SUITABLE FOR COMMUNITY ENERGY SCHEMES	72
5.2	OPTIONS FOR NEW ZEALAND COMMUNITIES	72
5.3	INCORPORATED SOCIETIES	73
5.3.1	THE EFFECTS AND BENEFITS OF INCORPORATION	74
5.3.2	REGISTRATION REQUIREMENTS	75
5.4	SPECIAL PARTNERSHIP	75
5.4.1	CHARACTERISTICS OF A SPECIAL PARTNERSHIP	75
5.4.2	ESTABLISHING A SPECIAL PARTNERSHIP	76
5.4.3	MAINTAINING A SPECIAL PARTNERSHIP	76
5.5	PRIVATE COMPANY	77
5.5.1	DEFINITION OF A PRIVATE COMPANY	77
5.5.2	ADVANTAGES AND DISADVANTAGES OF A PRIVATE COMPANY	77
5.5.3	FORMATION OF A COMPANY	78
5.5.4	CHARGES	79
5.6	SUMMARY AND RECOMMENDATIONS	79
6	THE RESOURCE MANAGEMENT ACT (1991)	81
<hr/>		
6.1	RESOURCE CONSENTS	81
6.1.1	TYPES OF RESOURCE CONSENT	81
6.1.2	APPLYING FOR A RESOURCE CONSENT	81
6.1.3	INFORMATION REQUIRED FOR RESOURCE CONSENT APPLICATION	82
6.2	TOTARA VALLEY	83
6.2.1	DESIGNATION	83
6.2.2	TARARUA DISTRICT PLAN	84
6.2.3	HORIZONS.MW LAND AND WATER PLAN	85
6.2.4	CONSENTS REQUIRED	88
6.3	D'URVILLE ISLAND	89
6.3.1	DESIGNATION	89
6.3.2	POLICIES AND OBJECTIVES	89
6.3.3	RULES	93
6.3.4	CONSENTS REQUIRED	94

7	ENERGY RESOURCE AND ELECTRICITY DEMAND	95
<hr/>		
7.1	TOTARA VALLEY	95
7.1.1	ENERGY RESOURCES	95
7.1.2	ELECTRICITY DEMAND	104
7.1.3	ENERGY EFFICIENCY OPTIONS	108
7.2	D'URVILLE ISLAND	111
7.2.1	ENERGY RESOURCES	111
7.2.2	ELECTRICITY DEMAND	118
8	RENEWABLE COMMUNITIES – COMPUTER MODEL	121
<hr/>		
8.1	ELECTRICITY DEMAND	121
8.1.1	TARIFFS	121
8.1.2	ELECTRICITY CONSUMPTION	122
8.2	HYDRO RESOURCE AND TECHNOLOGY	123
8.2.1	CALCULATIONS PERFORMED	123
8.2.2	TURBINE SUPPLIERS AND COST	124
8.2.3	RESOURCE CONSENTS	124
8.3	WIND RESOURCE AND TECHNOLOGY	125
8.3.1	REQUIRED INPUTS	125
8.3.2	WIND TURBINE DATABASE	127
8.3.3	WIND TURBINE SELECTION	127
8.4	SOLAR RESOURCE AND TECHNOLOGY	128
8.4.1	REQUIRED INPUTS	128
8.4.2	SOLAR PANEL DATABASE	130
8.4.3	PANEL SIZING	130
8.5	STORAGE, TRANSMISSION AND SITE WORKS	130
8.5.1	INPUTS REQUIRED	131
8.6	ANALYSIS	133
8.6.1	ANALYSIS OPTIONS	133
8.6.2	SYSTEM OPTIMISATION	133
8.6.3	ANALYSIS REPORT	134
9	RESULTS AND RECOMMENDATIONS	135
<hr/>		
9.1	TOTARA VALLEY	135

9.1.1	MODEL INPUTS	136
9.1.2	RESULTS AND RECOMMENDATIONS	136
9.2	D'URVILLE ISLAND	139
9.2.1	SCENARIOS CONSIDERED	139
9.2.2	MODEL INPUTS	141
9.2.3	RESULTS AND RECOMMENDATIONS	141
10 CONCLUSIONS AND SUMMARY		145
<hr/>		
10.1	RECOMMENDATIONS FOR FURTHER RESEARCH	147

List of Tables

	Page
Table 1.1: New Zealand's electrical energy sources in 1998	3
Table 2.1: A load analysis for a remote dwelling with six residents	25
Table 2.2: Correction factors for the float method of determining stream flow rate	35
Table 4.1: Summary of questionnaire response rates	52
Table 4.2: Energy resources on D'Urville Island, as identified by property owners	59
Table 5.1: Charges for registering as a company in New Zealand	79
Table 5.2: Required community size and registration costs for the recommended legal structures	79
Table 6.1: Type of consent available under the RMA	81
Table 7.1: Flow measurements at the Totara Stream culvert	97
Table 7.2: Maximum half hourly average load and total daily electricity consumption during shearing days at Farms 1 and 2	109
Table 7.3: Peak loads calculated for analysis scenarios	110
Table 7.4: Head, flow and pipe length measurements for six D'Urville Island streams identified as being suitable for micro-hydro development	112
Table 7.5: R ² values obtained using different types of trendlines	117
Table 8.1: Head limits used to determine micro hydro turbine type	124
Table 8.2: Surface Roughness Coefficients used in the model	126

Table 8.3: Ground reflectivity values used in the model	129
Table 9.1: Scenarios considered for the Totara Valley community analysis	135
Table 9.2: Cost of grid connection and renewable energy for Totara Valley scenarios	136
Table 9.3: Ratio of scenario cost allocated to each farm	137
Table 9.4: Scenarios considered for the D'Urville Island community	140
Table 9.5: Results of D'Urville Island analyses	141
Table 9.6: Annualised costs of options for each community member willing to be part of a renewable energy generating scheme on D'Urville Island	142
Table 9.7: The percentage of the total system cost allocated to each member	143

List of Figures

	Page
Figure 1.1: Energy consumed by sectors of New Zealand society	1
Figure 1.2: New Zealand's total primary energy production in 1998	3
Figure 2.1: Consumers assisted by RERC subsidies	9
Figure 2.2: The process of establishing a community owned renewable energy scheme	17
Figure 2.3: The process of applying for a resource consent	20
Figure 2.4: Flow chart showing the various parts of a renewable energy system and the flow of electricity through the system	21
Figure 2.5: Daily loading patterns for a house (a) in mid winter and (b) in mid spring	23
Figure 2.6: The photovoltaic effect in a silicon cell	27
Figure 2.7: The effects of wind turbulence over various land forms	29
Figure 2.8: The relationship between wind speed and the specific power output of a turbine	31
Figure 2.9: The power curve of a Windflow 500kW wind turbine	32
Figure 2.10: Types of wind turbine	32
Figure 2.11: The float method of measuring flow	35
Figure 2.12: Turbine selection chart for flows less than 200l/s	37
Figure 2.13: Turbine selection chart for flows up to 10,000l/s	37

Figure 2.14: Inverter wave forms	40
Figure 3.1: Topographic map of the Totara Valley	42
Figure 3.2: Map of D'Urville Island showing location of permanent residents	44
Figure 3.3: Topographic map of Akitio	47
Figure 4.1: Level of objection to sharing electricity with other community members	54
Figure 4.2: Energy sources used to meet heating and cooling loads	55
Figure 4.3: Level of satisfaction with present supply	56
Figure 4.4: View of how the community works together	56
Figure 4.5: Trust of other community members	57
Figure 4.6: Involvement in the community through meetings and community newsletters	57
Figure 4.7: Level of support for a community owned renewable energy scheme	57
Figure 4.8: Uptake of energy efficient practices	58
Figure 4.9: Income sources for D'Urville Island	59
Figure 4.10: Level of objection to supplying other community members with electricity generated on respondents' properties	60
Figure 4.11: Level of objection to being supplied with electricity generated on other properties	60
Figure 4.12: Willingness of respondents to generate electricity on their own properties	61
Figure 4.13: Energy sources used to meet heating and cooling loads	62
Figure 4.14: Grid connected customers' satisfaction with their present power supply	62
Figure 4.15: View of how the community works together	63
Figure 4.16: Trust of other community members	63
Figure 4.17: Involvement in the community through meetings and community newsletters	64
Figure 4.18: Level of support for a community owned and operated renewable energy scheme	64
Figure 4.19: Uptake of energy efficient practices	65
Figure 4.20: Income sources of Akitio respondents	65

Figure 4.21: Level of objection to supplying other community members with electricity generated on respondents' properties	66
Figure 4.22: Energy sources used to meet heating and cooling loads	67
Figure 4.23: Grid connected customers' satisfaction with their present power supply	68
Figure 4.24: View of how the community works together	68
Figure 4.25: Trust of other community members	69
Figure 4.26: Involvement in the community through meetings and community newsletters	69
Figure 4.27: Level of support for a community owned renewable energy scheme	69
Figure 4.28: Uptake of energy efficient practices	70
Figure 7.1: Location of energy resources and buildings	95
Figure 7.2: The culvert used to measure flow in the Totara Stream	96
Figure 7.3: Culvert dimensions	97
Figure 7.4: The second stream identified within the Totara Valley catchment	98
Figure 7.5: The wind monitoring equipment	99
Figure 7.6: Average monthly wind speeds for Totara Valley in 1999	100
Figure 7.7: Windspeed distribution and calculated and optimised Weibull curves for the period 26/02/1999 to 26/02/2000	101
Figure 7.8: Percentage of the monitoring period that the wind blew from each direction	102
Figure 7.9: The solarimeter used to monitor global solar radiation	102
Figure 7.10: Global solar radiation in 1999	103
Figure 7.11: Monthly electricity consumption profile based on Scanpower data	105
Figure 7.12: The author downloading data from Siemens meters	105
Figure 7.13: Electricity consumption profiles for Totara Valley properties	106
Figure 7.14: Electricity consumption during a day of shearing at Farm 1 (20/01/2000)	108
Figure 7.15: Electricity consumption during a day of shearing at Farm 2 (5/12/1999)	109

Figure 7.16: (a) Wind monitoring equipment installed at the D'Urville Island site	(b) the view to the saddle where the anemometer was sited	112
Figure 7.17: Monthly average wind speed for the D'Urville Island site		113
Figure 7.18: Wind speed distribution and calculated and optimised Weibull curves for the period 10/11/1999 to 01/03/2000		114
Figure 7.19: Percentage of the monitoring period that the wind blew from each direction		114
Figure 7.20: Average daily global solar radiation (10/11/1999 to 01/03/2000)		115
Figure 7.21: Scatter plot of D'Urville Island and Nelson Airport hourly average wind speed data (10/11/1999 to 31/12/1999)		116
Figure 7.22: Scatter plot of D'Urville Island and Nelson global solar radiation data (11/11/1999 to 29/02/2000)		117
Figure 7.23: Average daily global solar radiation levels for D'Urville Island, correlated from historical Nelson Airport data ($R^2 = 0.68$)		118
Figure 7.24: Location of properties where load meters were installed.		119
Figure 7.25: Annual electricity consumption of 11 D'Urville Island landowners willing to be part of a community scheme		120
Figure 8.1: Energy and network tariff input page		122
Figure 8.2: Hydro analysis input page		123
Figure 8.3: Wind analysis input page		125
Figure 8.4: Solar analysis input page		128
Figure 8.5: Storage and transmission and site works input pages		131
Figure 8.6: Example of a summary report prepared by the computer model		134
Figure 9.1: Cost of scenarios to each farm (including water heating))		138
Figure 9.2: The location of community members interested in being part of a renewable energy electricity generating scheme		139

1 Introduction

1.1 Electricity in New Zealand Today

New Zealand is a country which depends upon electricity. In 1998 31400 GWh of electricity was used to supply industry, agriculture, commercial businesses, and residential properties. Figure 1.1 shows the distribution of consumed electricity amongst these energy users.

Figure 1.1: Energy consumed by sectors of New Zealand society

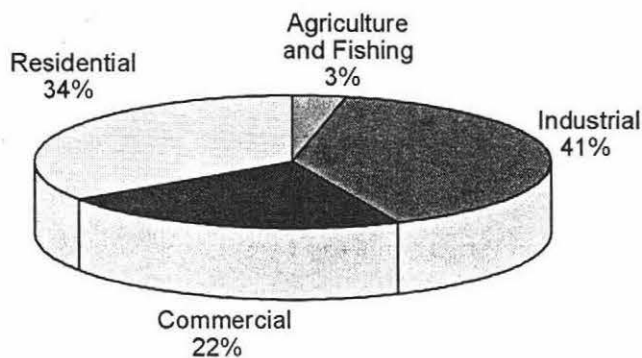

(Source: Ministry of Commerce, 2000)

The supply of electricity to rural New Zealand in the past has enabled our country to be built on the successes of rural producers. The success of our agriculture industry has generally reflected the success of the country as a whole, and until the last few years the rural sector has been well provided for, receiving the level of electricity services it deserves. This may no longer be the case, and it is this loss of service quality that has provided the impetus for this research to be carried out.

1.2 Factors Influencing This Study

There are two major factors which have brought about the need for this study. The first is the threat which rural electricity consumers face of either eventually having to pay the large true cost of supplying electricity to their homes, or losing their existing grid

connections as lines companies shut down uneconomic lines after 2013. The rural community has already had to fight to maintain some its crucial services, such as Post Offices, schools, and service stations.

At the 1998 conference of the Sustainable Energy Forum (SEF 1998), it was acknowledged that the issue of electricity supply to rural customers is not going to disappear, and that rural dwellers need to be proactive in seeking a solution to the problem before they are charged the full price of supplying their power. The conference concluded that a study looking at the possibility of setting up community owned and operated renewable energy schemes would be an investigation of benefit to many rural communities throughout New Zealand.

The second factor is the need to protect the local and global environment and to move towards a more sustainable lifestyle. At present New Zealand is still reliant on non-renewable sources for 25% of its electricity needs, which compares favourably with other similarly developed countries such as Australia and the United States. However, the non – renewable sources being utilised are producing greenhouse gases, which are associated with the problem of global warming. Although New Zealand is a relatively small country which contributes a very small proportion of greenhouse gases to the global atmosphere, it should be moving away from fossil fuels towards the renewable resources of water, sunshine, wind and biomass.

A possible solution to these problems is the development of small scale, community owned power generation schemes in rural areas throughout the country. Ideally these would be based on the local renewable energy resources available to the community. The cost of electricity generated from renewable energy systems is decreasing as the market for equipment grows and greater conversion efficiencies are achieved. This is, therefore, an appropriate time to start looking at the ways in which these resources can be utilised to a far greater extent.

This thesis outlines the theoretical issues pertaining to the setting up of a community owned and operated renewable energy scheme and seeks to provide an analysis framework which can be useful in the future when more communities will be threatened with price rises or the loss of their electricity distribution lines.

1.3 The Present Role of Renewable Energy Sources in New Zealand

New Zealand has a long association with renewable energy. Electricity is generated from hydro, gas, geothermal, and coal sources. Table 1.1 below gives a summary of the energy produced from each of these sources, and the percentage of total production that they contribute.

Table 1.1: New Zealand's electrical energy sources in 1998

Total Electricity Generated (GWh) = 36300		
Electrical Energy Source	GWh Produced	% of Total Production
Hydro	23595	65
Gas	8349	23
Geothermal	2178	6
Coal	1815	5
Other	363	1

(Source: Ministry of Commerce, 2000)

Although these statistics give the impression that a sustainable energy future is approaching, a look at our overall energy consumption reveals the opposite. Figure 1.2 shows the sources of our overall energy production, and the percentage of total produced energy that each source provides.

Figure 1.2: New Zealand's total primary energy production in 1998

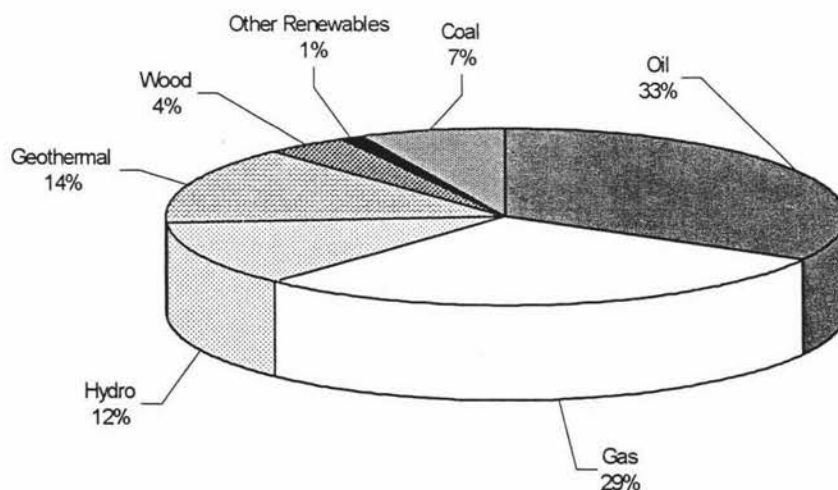

(Source: Ministry of Commerce, 2000)

The renewable energy sources of wood, hydro, geothermal and other renewables have a combined contribution of 31%. New Zealand is therefore still reliant on non-renewable sources for the majority of its energy requirements.

Apart from the larger scale hydro and geothermal plants in operation today, renewable energy sources are poorly utilised in this country. It has only been in the past few years that the possibility of using wind farms for large scale generation has been seriously investigated. These investigations have resulted in the construction of the 3.5MW Hau Nui wind farm in the Wairarapa and the 32MW Tararua Wind Farm on the ranges overlooking Palmerston North. Plans for other wind farms on both sides of the Manawatu Gorge are also being evaluated.

New Zealanders are slowly becoming more aware of the need to be 'green' in the way they live, so renewable energy has become an attractive option. One growth area for renewable energy is in the rural sector, with people living in the more remote parts of the country opting to generate their own electricity, rather than connect to the national grid.

A survey of renewable energy equipment suppliers by Massey University students (Shaw *et. al.*, 1996) was carried out for the Energy Efficiency and Conservation Authority (EECA). It concluded that 37% of the companies surveyed were receiving over 30 new clients a year, with some of these fielding over 1000 enquiries a year. The report concluded that the Remote Area Power Systems market in New Zealand is increasing and should continue to increase following changes to the electricity supply market.

1.4 Objectives

The overall goal of this study was to develop an analysis framework and computer model that will be able to identify the renewable energy option best suited to a given rural community looking at setting up an independent, community owned and operated generating scheme.

The specific objectives used to reach this goal were to:

- review the literature relating to
 - small scale hydro-electric, wind and solar electricity generation and the design processes involved in developing an optimum generating scheme;
 - the past and present structure of the New Zealand electricity market and the impacts that changes have had on rural communities;
 - New Zealand law which relates to this project;
 - past experience with community owned schemes overseas;
- identify three case study sites which differ in size, demographics, main form of income generation (e.g. sheep and beef farming, fishing, forestry etc.) and proximity to the national grid;
- obtain the support of these communities and work with them to measure their present electricity requirements, usage patterns and lifestyle choices;
- establish a number of independent electricity generation scenarios for each community, and provide details of equipment required, environmental impacts, the implications of the Resource Management Act, and the economics;
- develop an analysis framework that draws on all the information and experience gathered from working with the case study communities. This will be used for future community based schemes by Powerflow Ltd, the sponsor company for this study;
- make recommendations for further research and identify any existing technology gaps which would restrict the success of community owned power generation schemes.

1.5 Scope

There were limitations to the scope of this project. This study was intended to be theoretical and lead on to the practical work of constructing the schemes. The scope covers the selection of case study sites, the monitoring of their resources and energy use, and the design and recommendation of a power generation scheme for each site. It does not cover the obtaining resource consents, installing the generating equipment and taking the scheme to the point where the community is ready to take ownership and control of it. This would be the role of a renewable energy developer.

A limitation to the study was the range of generation options considered for each case study community. These have been limited to micro-hydro, wind and solar generation, primarily because these are the most common and therefore the cheapest forms of electricity generation. Experience has proven these generation technologies, and there are many instances around New Zealand today where these technologies are being put to good and reliable use. Biomass and energy cropping have not been included in this study as the scale of plants tends to be 10MW or greater, which is beyond the requirements of small rural communities.

The inclusion of diesel generators as a back up power source was also not investigated as it was not considered necessary by Powerflow Ltd

Renewable energy systems can be grid connected, so that any surplus power can be sold back to the retailer and electricity can be purchased when generation at the site is insufficient. In this case the grid effectively acts as a battery. This study is limited to the examination of independent off-grid systems only, although similar principles apply to renewable energy system design for either case.

1.6 Report Structure

The structure of the report is given below, together with a summary of the methodology used.

Chapter 2

A review of the literature relating to the project. It summarises the history of electricity in New Zealand, the technology required for renewable energy development, and overseas experience relating to the social and legal aspects of community owned schemes.

Chapter 3

A description of the case study sites including location, topography and geology, the local population density, and the properties included in the study.

Chapter 4

Details of the process used to develop a user survey are given, along with a summary of the survey results.

Chapter 5

An investigation into the most suitable forms of legal ownership for rural communities in New Zealand was conducted. An overview of the different structures is given, and recommendations are made.

Chapter 6

The implications of the Resource Management Act as it relates to the development of renewable energy at the case study sites are provided. This chapter looks at the district and regional plans and summarises the rules which would hinder the development of renewable energy resources for electricity generation in rural power schemes.

Chapter 7

A description of the available renewable energy resource and electrical load from monitoring that has taken place at the case study sites is presented. The correlation of recorded weather data with historical data is also detailed.

Chapter 8

An overview of the computer model, detailing the inputs required and the logical process it follows. Calculations used within the model are given in Appendix A.

Chapter 9

Results of analyses carried out using the model are presented, based on the case study data presented in earlier chapters. A summary of the options for communities is given and recommendations are made.

Chapter 10

Conclusions of the study are presented, together with identification of future research requirements.

2 Distributed Power Supply Systems - Literature Review

This chapter reviews existing literature and gives an overview of recent research relating to the development of community owned and operated renewable energy schemes. The review has been broken down into:

- the history of the New Zealand electricity supply industry and its relationship with the rural sector;
- the ownership and management structures most suitable for developing and operating remote renewable energy schemes;
- a review of recent New Zealand law pertaining to the study;
- an introduction to the theory of designing a renewable energy system, including an overview of the technology available, the resources required and the critical factors in system design. A review of potential environmental impacts is also given.

2.1 The History of Rural Electricity Reticulation in New Zealand

Most New Zealanders consider a reliable and secure electricity supply essential. Until now this supply has been provided to 99% of the population, with the Rural Electrical Reticulation Council (RERC) enabling many remote rural communities to be connected to the national grid.

Electricity was first offered for public sale in New Zealand in 1888 from a hydro scheme in the gold mining town of Reefton, but it was met with a feeling of curiosity rather than celebration (Paris, 1996). Gradually electricity became more common, and its use extended beyond powering the original gold stamping batteries to providing energy for lighting, household appliances and electric trams.

The first legal act relating to electricity came in 1884 with the Electric Lines Act, but the government kept its distance from electricity related issues until 1914 when it opened the Lake Coleridge hydro power station. From this beginning the reticulation of electricity around New Zealand grew, and in 1918 the Power Boards Act was introduced. As a result of this act, the percentage of the population supplied with electricity grew from 50% in 1920 to 93% in 1938 (Paris, 1996). The provision of

electricity to the rural population was seen as particularly important at this stage as it was considered that:

“...farming is the mainstay of the country, and it is our duty to do everything to forward that industry, because if that industry prospers all other industries must profit by its prosperity. If the farmer is doing well the city men are doing the same.” (Cairncross, 1895, quoted in Paris, 1996)

The next major change came with the Electricity Act 1945. This act saw the Public Works Department take responsibility for the building of hydro dams, while the new State Hydro-electric Department was given the task of co-ordinating the ongoing supply of electricity to the country. The major change which came with this act was the introduction of the RERC, which was set up to help fund future rural reticulation projects. The RERC was funded by the State and individual supply authorities and its purpose was to provide subsidies to rural consumers to enable them to connect their properties to the national grid.

Rural reticulation continued under the control of the RERC, with most of their work being carried out in the period from 1950 to 1965 (Figure 2.1). By the early 1960's the work of the RERC was becoming less clear cut, with far fewer obvious cases for subsidies. The council was receiving an ever-decreasing amount of funding from supply authorities, making its goals more difficult to achieve.

Figure 2.1: Consumers assisted by RERC subsidies

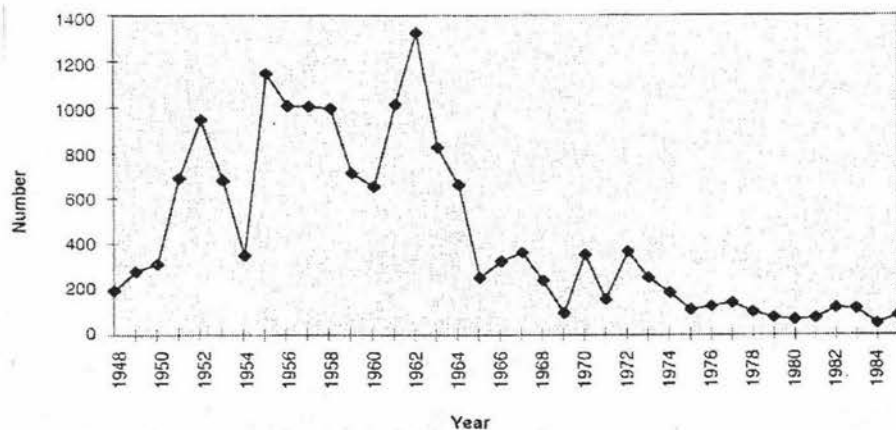

(Source: Paris, 1996)

During the 1980's, the government made significant changes to the electricity market, resulting ultimately in the deregulation of the electricity distribution business. A

working party set up by the government to look at the implications of deregulation concluded that while the energy component of charges would remain unchanged, the cost of distribution could increase by two or three times for some rural consumers (Paris, 1996). The RERC also identified 200,000 rural dwellers who would be affected by these changes. The Electricity Act 1992 ensured the adequate maintenance of lines for all connected electricity consumers for another 20 years, and the Minister of Energy was given the right to control domestic power prices for five years.

From 1993 onwards the RERC was downgraded to simply monitor and advise the Ministry of Energy on issues relating to rural customers, and was eventually dissolved in 1997 leaving the rural consumers in the hands of the power lines companies.

2.1.1 The Present Situation

There have been a number of significant changes in the electricity market over the last six years. The major change was the formation of 'Energy Companies', which were made responsible for the generation and retailing of electricity under the Energy Companies Act 1992. These new energy companies were either publicly listed or managed by consumer elected trusts, with both being required to operate as "successful businesses" under the act (Gunn, 1996). In a study of the operating objectives of these companies, Gunn concluded that profit maximisation would be the main priority. Until 1998 energy companies had two distinct functions: energy retailing and lines business. The energy retailing section was responsible for the purchasing of wholesale electricity and selling it to their consumers, while the lines business was responsible for operating and maintaining the local distribution network (Gunn, 1996). In 1998, under the Electricity Industry Reform Act, the two sections of energy companies were forced to split into separate businesses in an effort to encourage competition.

The long term effects of these changes are not yet known, but power companies are predicting that a rise in electricity prices for rural consumers is inevitable (Bloemink, 1998). The Energy Foundation (1996) concluded that "overall prices will rise, possibly significantly, due to the declining use of natural gas, environmental restrictions and the fact that future electricity generation will be provided by private investors fully exposed to the risks of the power sector and requiring a compensating financial return". The low population densities of New Zealand's rural communities also make them the most

uneconomic customers that the new lines companies will supply, so price rises are also expected from both sectors of the electricity industry.

The New Zealand government is now beginning to realise that the issue of electricity supply to rural areas must be addressed, with the Minister of Energy stating that the government aims to “promote the development of technologically reliable remote area power systems which will be particularly important to remote rural areas” (SEF, 2000). A report prepared by the Parliamentary Commissioner for the Environment also stated that “the use of renewable energy acts as one of the more obvious contributors to sustainability by:

- reducing local environmental pollution and greenhouse gas emissions;
- providing alternative and often local sources of energy supply which increases energy security;
- reducing dependence on non-renewable fossil fuels;
- enabling distributed and independent power supplies to be developed in rural communities; and
- potentially reducing the cost of energy supply.” (Parliamentary Commissioner for the Environment, 2000)

In the long term there is a very real threat that remote customers will have their connections cut by the power lines companies themselves, under Section 62 of the Electricity Act 1992.

2.2 Community Owned Renewable Energy Schemes

One option for rural communities wanting to overcome the predicted electricity price rises is to establish a community owned and operated renewable energy scheme. As there are no such schemes in New Zealand at present, the literature reviewed in this section is based on overseas experience. Community based schemes have been established in both developed and developing nations (e.g. UK, Sweden, Denmark, Australia, Nepal, India) but the social, economic and political environments in which these schemes operate are very different to New Zealand.

2.2.1 Overseas Experience

The uptake of renewable energy in Europe is considerably greater than in New Zealand due to Europe's dependence on non-renewable energy sources. In Denmark the production of energy from coal, oil, gas and uranium was the focus for energy planners, and it was not until 1978 that the option of using the renewable sources of wind and sun were seriously considered.

Since 1978 significant progress has been made in the uptake of renewable energy sources in Europe and around the world. Denmark now has 900 megawatts of wind power capacity and is the world leader in cooperatively owned wind turbines (Tranaes, 1997).

2.2.1.1 Overseas Example – Harlock Hill

One example of a community owned renewable energy system is the Harlock Hill scheme, located near Ulverston in South Cumbria, UK.

This scheme is based around a relationship between The Wind Company, who were responsible for the installation and maintenance of the turbines, and a cooperative of approximately 1200 people called the Baywind Energy Cooperative, who provide finance for the turbines.

The Wind Company was set up in 1994 by a Swedish company, Vindkompaniet, to introduce the concept of cooperatively owned turbines to the UK. The Wind Company initially purchased five Wind World 500kW turbines and completed the installation at the beginning of 1997. This ensured that the turbines were correctly constructed and maintained by professionals. The electricity generated by the turbines was sold to the national grid through the local electricity company, NORWEB (Baywind News, 1996).

Baywind was then able to purchase the turbines from The Wind Company as the necessary finances were raised through its £3,100,000 share issue (Boxer, 1995). The benefits of owning shares in Baywind were estimated to be a return on investment of 7% over 15 years. Baywind members had the option of receiving their annual dividend as a cash payment or having it deducted from their electricity accounts with NORWEB.

The benefits of the cooperative structure used at Harlock Hill are:

- a democratic structure which means each member has one vote, regardless of the number of shares they own;
- local ownership which is essential for long term project sustainability;
- cooperative members gain knowledge in the wind industry and associated technology;
- local financial benefit through the return of dividends to cooperative members, and the employment of local residents during the construction of the turbines;
- positive environmental action which all members can be a part of.

2.2.2 Community Strengthening

The ownership of renewable energy systems by rural communities is expected to have a number of benefits for the community involved:

- communities being able to provide for their own energy requirements;
- the ability to plan surplus power allocation to community enterprises such as tourism, small scale local industry, or selling power back to the national grid;
- responsible energy utilisation and increased respect for the environment;
- development of local skills to maintain the electricity supply (Woods, 1997);
- an increase in cooperation, coordination and communication between members of the community (MAF, 1992);
- a feeling of community self satisfaction;
- financial returns for the community members (Mitchell, 1995).

2.2.3 Urban Drift

Urban drift is an area of particular concern in New Zealand today. The present loss of services to rural areas has begun to have an effect on the farming communities with regard to roading, health and education. Margaret Millard, the national finance chair of the Women's Division of Federated Farmers, commented:

"In the end we are residual recipients of the money coming from our industry and of government policies. But New Zealand is still dependent on agriculture, and the infrastructure which allows that industry to operate. It seems that today this point is forgotten." (SEF, 1998)

The present situation with electricity supply to rural areas is inhibiting rural settlement, and may eventually lead to urban drift and further rural depopulation, with all its associated social, environmental and economic problems (Woods, 1997).

2.2.4 Project Ownership and Leadership

One of the features of this study is the aspect of community ownership. It is argued that if schemes involve some form of local control and economic benefits for the local community, the impacts of the scheme may be judged more favourably by the community (Elliot, 1997). The experience of community ownership in Denmark has led to a far more rapid acceptance and development of renewable energy projects than elsewhere in Europe (Mitchell, 1995). There are a number of options available for project ownership and leadership, as outlined below.

2.2.4.1 Ownership

The ownership of a community based renewable energy scheme needs to be discussed and agreed upon at the earliest stages of a project, so that all local residents are aware of their ownership position and responsibilities. The ownership structure must be fair, and benefit all residents. This will reduce any opposition to a project from the outset.

The ownership structure chosen will depend on the financial situation in the country in which the renewable energy development is taking place. A major factor is the presence or absence of tax incentives for renewable energy projects. These incentives have a large impact on the ownership of overseas projects, but no such incentives exist in New Zealand.

Mitchell (1995) proposed six legal structures which can be used in this type of project:

1. Private company limited by shares - a company which is not listed on any stock exchange. Shares cannot be sold to the public.
2. Public company limited by shares - shares may be listed on a stock exchange, but this is unlikely for a community project. Shares are sold to the public.
3. Private companies limited by guarantee and having no share capital - this structure is often used for non-profit organisations where profits are never distributed but are reinvested in the company.

4. Industrial and provident society - this is a corporate body with limited liability which may be registered as either a cooperative society or a society for the benefit of the community. These are often used for organisations with a social as well as an economic purpose.
5. Charities
6. Limited Partnership - this is a partnership deed created between less than 20 people. The members are jointly and severally liable for the debts of the partnership.

Mitchell (1995) concluded that for a community owned electricity generating scheme most communities would opt for either a public limited company or an industrial and provident society. Schoenrich (1997) concluded that limited liability companies or limited liability partnerships are the best option for privately owned wind projects in the United States.

2.2.4.2 Leadership

The leadership of a community owned renewable energy scheme may have a significant impact on its success. The structure needs to be established early, so that all members of the community know where the direction for the project is coming from. Mitchell (1995) detailed common options used for community ownership:

1. Small group - formed within the community to take control of the project and manage its construction and operation. Some outside experts may need to be brought in, but the overall control of the project remains with the community.
2. Developer - led by a developer from the start to finish, aiming to establish a renewable energy project and sell power to the community.
3. Existing organisation - controlled by an existing organisation, such as a development trust or registered charity.

2.2.5 Consultation

The success of a project which works with a community of any kind is dependent on good consultation practices (Elliot, 1997). The importance of respecting the cultural and social norms of local residents and ensuring the project has broad community acceptance is well documented (Elliot, 1997; FAO 1990; MAF, 1992; Woods, 1997). Consultation must take place throughout the duration of the project. Within the context of a community based project, good consultation can:

- clarify and review over time the objectives of all groups affected;
- ensure that relevant information is collected and available, and that key issues are identified as early as possible;
- alert the primary community, and all other parties, about social effects so that strategies can be adopted to mitigate them if required;
- encourage information exchange between all parties associated with the project (MAF, 1992).

Mitchell (1995) described the process of community involvement as having four important steps:

1. the formation of a core team;
2. raising the awareness of the community;
3. securing commitment from the community;
4. creating a legal structure through which the project will operate.

Figure 2.2 shows the full process of setting up a community owned and operated renewable energy scheme in the UK and indicates where these important aspects of community involvement fit into the overall picture. Woods (1997) proposed a similar process for the establishment of a community owned and operated scheme in New Zealand. His process also emphasised the need to educate the community about the technology they would be utilising, as this would be vital for the long term success of a scheme.

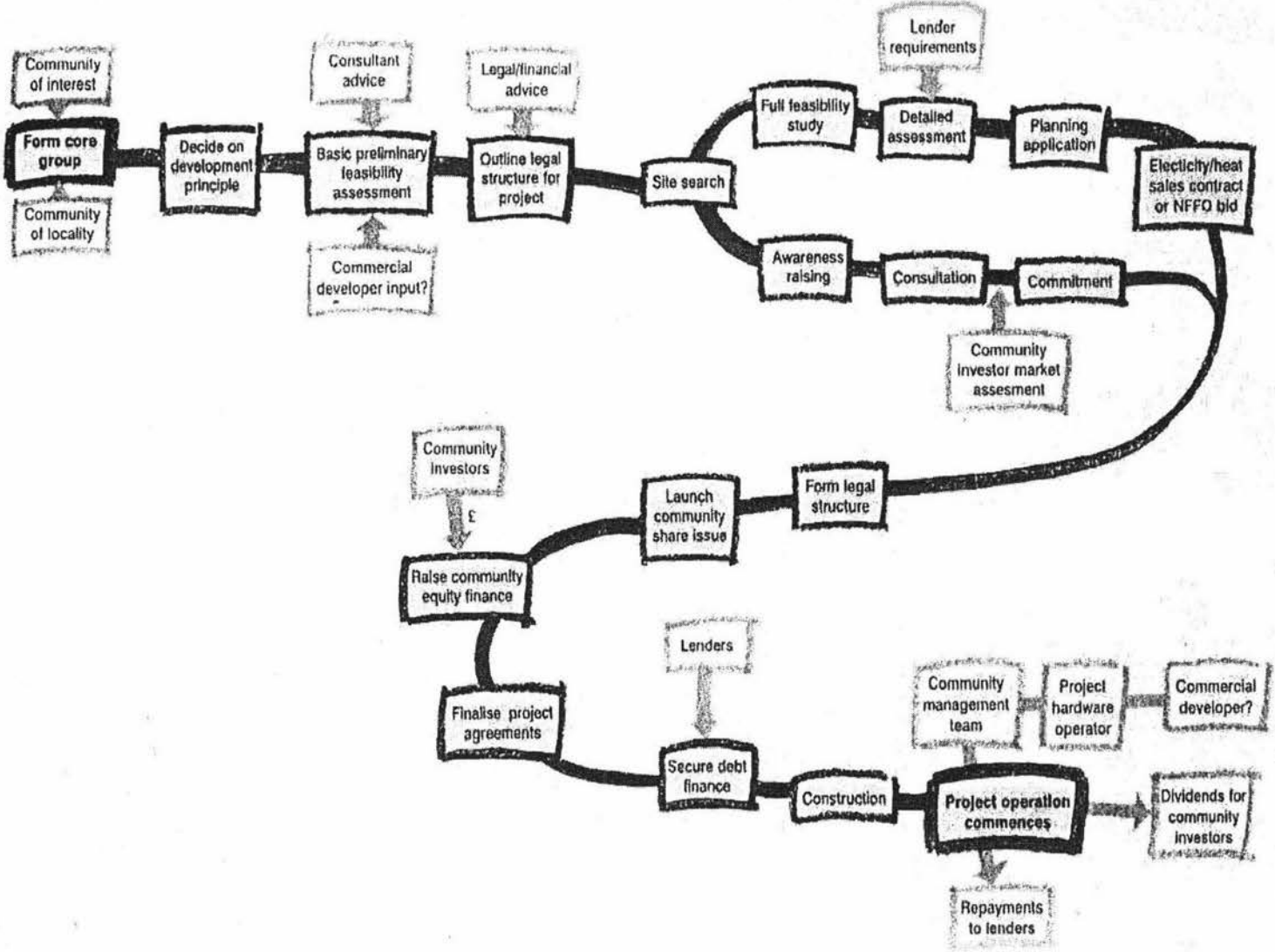

(Source: Mitchell, 1995)

Figure 2.2: The process of establishing a community owned renewable energy scheme

2.3 Relevant Law

There are a number of pieces of legislation which have an impact on the establishment of independent or grid connected power supply systems. These are reviewed and their implications discussed.

2.3.1 Electricity Act 1992

The Electricity Act 1992 will have the greatest impact on the rural sector of New Zealand society, due to the inclusion of a subsection at the end of Section 62.

Every electricity distributor holding a licence issued under Section 20 of the Electricity Act 1968 must “not cease to supply line function services ... without the prior consent of the minister or of every consumer who would be affected by the cessation of those services.”

This statement appears to give a high level of security to rural consumers, but the act does not finish there. In Section 62.6, it states: “This section shall expire with the close of the 31st day of March 2013, and on the 1st day of April 2013 this section shall be deemed to have been repealed.”

This effectively gives electricity lines companies the option of cutting off supply to uneconomic customers after April 1st 2013. Rural dwellers are the most uneconomic consumers due to the long lines required to supply a very low density population using limited quantities of power.

When this Act was introduced, Section 62 was strenuously but unsuccessfully opposed by the RERC because of their concerns about the future impact of such a decision on rural communities.

2.3.2 Electricity Industry Reform Act 1998

This Act produced the official split of the existing power companies into separate line and energy companies. Part 6: Price Restraint for Line Charges for Domestic And Rural Consumers relates to this study. This gives power to the Governor General to place

restraints on prices charged by lines companies, as lines companies will still be trading as monopolies with no competition to force prices down.

This Act also sets limits on the size of lines and energy companies. A lines company only comes under the authority of the Act if it transmits more than 2.5 GWh/year (= 6850 kWh/day on average). An energy company is also allowed to generate up to 2.5 GWh/year before it comes under the authority of the act.

2.3.3 Resources Management Act (RMA) 1991

The RMA is relevant to this study through the limits it puts on the way natural resources are used. The purpose of the Act is “to promote the sustainable management of natural and physical resources.” (RMA, 1991). The Act details restrictions for the use of land (Sections 9 - 11), coastal marine areas (Section 12), river and lake beds (Section 13), and water (Section 14). It also gives guidelines on acceptable behaviour relating to noise (Section 16), the discharge of contaminants (Section 15), and adverse effects on the environment (Section 17).

The Act is administered through City, District and Regional councils in the form of council plans. These plans vary between councils, but are all based on the guidelines set out in the RMA.

The process of applying for resource consents (or permission to undertake activities that do not comply with the council plans) is specified in the RMA (Part VI). This process must be followed for all consents required for a particular activity. A flowchart detailing the process is given below (Figure 2.3).

Figure 2.3: The process of applying for a resource consent

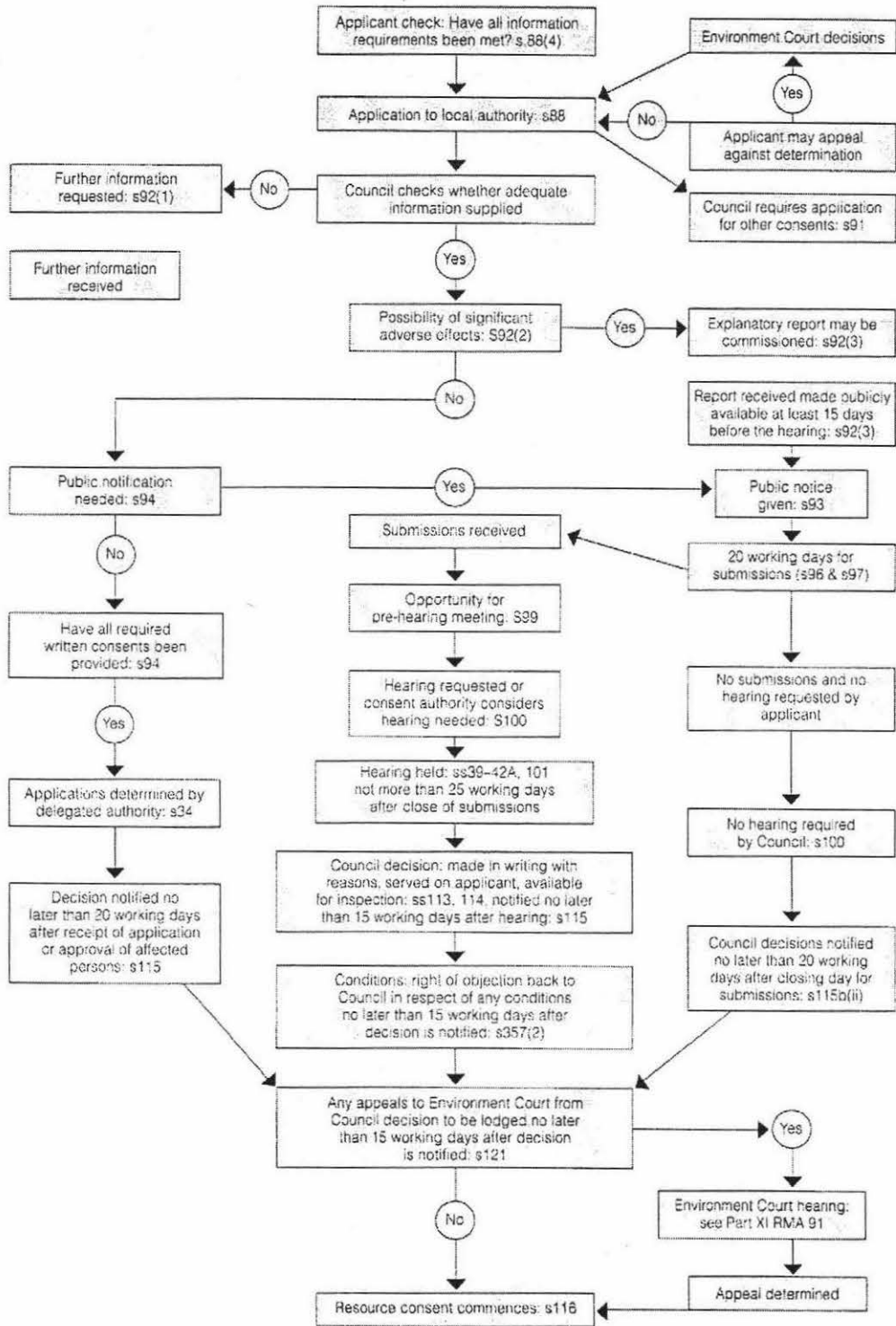

(Source: EECA, 1996)

2.4 Renewable Energy - The Design Process

The theory and practice associated with designing a renewable energy generating scheme for rural applications, using a combination of hydro, wind and solar energy is reviewed in this section.

2.4.1 Design Process Overview

The various parts of a renewable energy system are interrelated (Figure 2.4). The design process for a generating system essentially involves working step by step from the energy resource to delivery of power to the appliances within the building.

Figure 2.4: Flow chart showing the various parts of a renewable energy system and the flow of electricity through the system

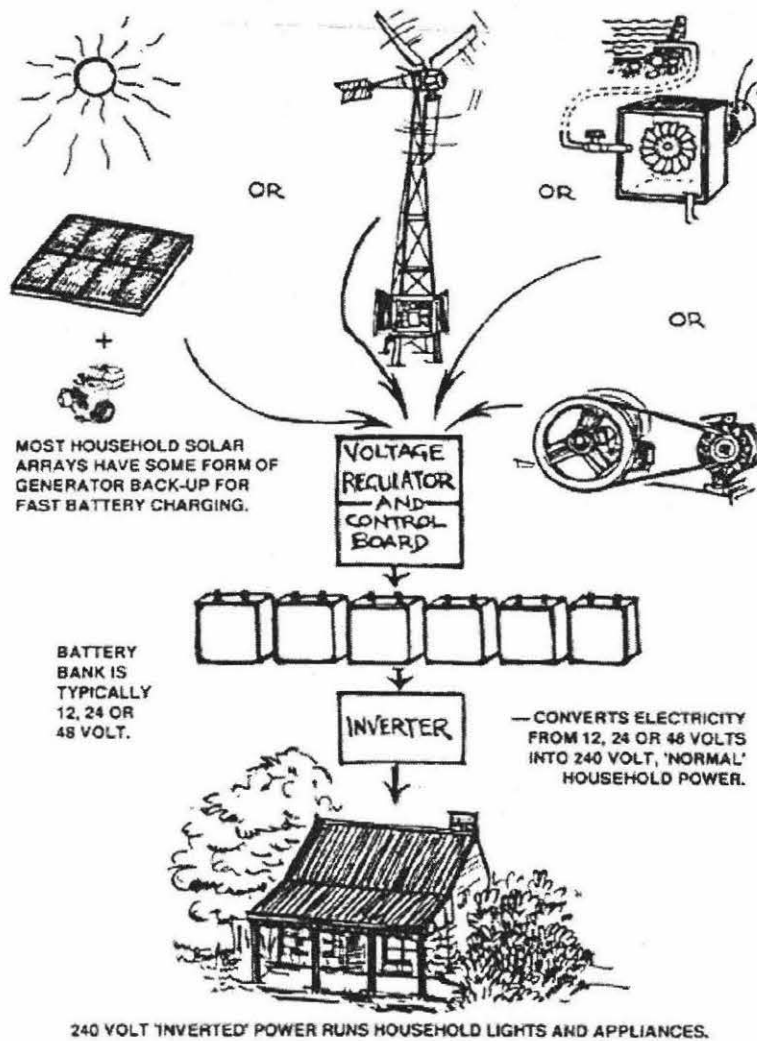

(Source: Gray, 1996)

The first step of the process is the determination of loading patterns, or the amount of electricity that a property, business or community will use, and when (Gray, 1996). The loading pattern needs to take into account all the activities that will take place on a property, and the seasonal variations in these activities.

The second step is to evaluate the energy resources that are available at the installation site. This involves gathering data on average windspeed and wind direction, sunshine hours or global radiation, location latitude, stream flow rates and available head. Once these values have been quantified the power available from each source can be determined. It may be necessary to consider using a diesel generator when designing the system to provide some form of back up if there is a possibility of power shortages occurring.

If wind or solar energy are to be harnessed, the next step is to look at the storage of the electricity, which is usually in the form of batteries for small scale schemes (Gray, 1996). Questions that need to be answered in this phase of the design process are:

- how many batteries and what capacity are required?
- what voltage(s) would be best for the appliances needing to be powered? The options here are generally 12, 24,48,110 or 240 volts (Gray, 1996). 240V is usually the best option as appliances are mass produced at this voltage and are therefore cheaper.
- what type of battery (e.g. lead acid, ni-cad, nickel-iron) is best suited to the application?
- what form of power regulation is required to protect the batteries from being overcharged?

After the battery bank has been designed the next step is to look at the option of using an inverter to convert the power from low voltage DC electricity to high voltage AC electricity. This decision should be well researched, as there is a range of inverters available, with widely varying prices.

2.4.2 Loading Patterns

Determining the electrical demand that the system must meet needs to be done as accurately as possible to ensure that the system is neither undersized and not able to provide enough electricity, nor oversized and more costly than it needs to be.

Electrical loading varies over the course of a day, with an even greater variation between weekdays and weekends and with the different seasons of the year. A study of electrical consumption carried out in Christchurch during 1996 (EECA, 1997) identified variations in daily, weekday/weekend and seasonal electricity usage (Figure 2.5).

Figure 2.5: Daily loading patterns for a house (a) in mid winter and (b) in mid spring

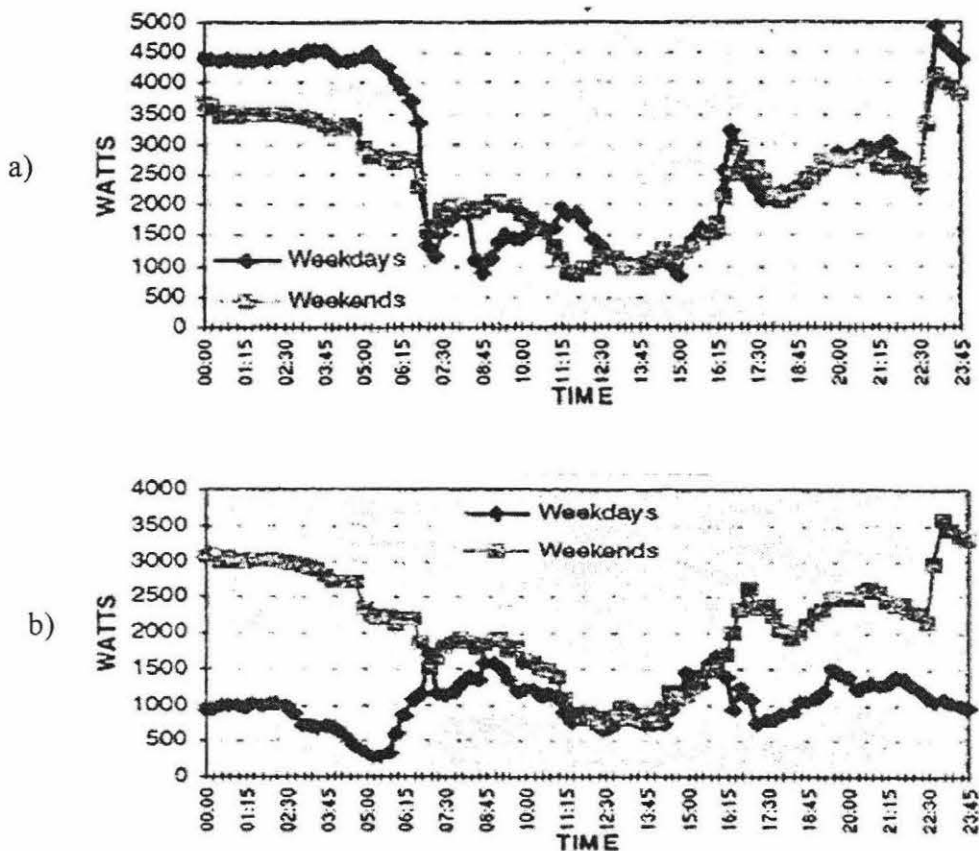

(Source: EECA, 1997)

For the purposes of small scale renewable energy system design it is not necessary to measure loading patterns to this degree of detail, but it is useful to be aware of the fluctuations that can occur. The profile assessment method detailed in Section 2.4.2.2 is recommended.

2.4.2.1 Energy Efficiency

The adoption of energy efficiency measures is one of the easiest ways to reduce electricity consumption. Typical examples of energy efficiency options in the home include using gas or wood for cooking and heating, energy efficient lighting, hot water cylinder wraps, solar water heaters, and draught stopping. Lifestyle choices (e.g. turning off lights when they are not in use) can also reduce electricity consumption.

A small community can also reduce their electricity consumption by sharing their resources. An example of this is a small rural community sharing one large freezer, instead of each member having their own under-utilised freezer.

2.4.2.2 Determining Electricity Demand Profiles

The demand profile can be assessed using the following procedure (Weiss, 1992):

1. Identify which appliances will be using electricity generated from the renewable energy source, irrespective of where they are located (e.g. power tools used in garages, exterior lighting, security alarms). A load analysis table (Table 2.1) detailing these appliances should then be drawn up.
2. Determine the power rating of each appliance and record these in the load analysis table. These values can usually be found on the appliance label.
3. Estimate the average number of hours each appliance is used in a day. Multiplying this time by the wattage of the appliance gives the number of watt-hours consumed per day by each appliance.
4. The total power consumption per day is calculated by summing the values in the kWh/day column. This indicates how much power needs to be generated daily to meet the appliance electrical demand.
5. The peak load (in kW) is calculated by adding up all the appliances which might run together at the same time. This is particularly crucial for kitchen appliances (e.g. toaster, microwave oven, kettle), as heating appliances have relatively high power ratings.
6. The line current capacity requirement at peak loading is calculated by dividing the peak power load by the voltage the system is operating on. This determines the maximum current flowing through the wires of the system.

Table 2.1: A load analysis for a remote dwelling with six residents

Appliance	Approximate Power Rating (W)	Hours use per day	kWh/day
Electric Clock	10	24	0.24
Coffee Machine	700	0.25	0.175
Colour TV	300	2	0.6
Freezer	200	11	2.2
Fridge	250	15	3.75
Hair Drier	400	0.5	0.2
Heating	Wood only	-	0
Iron	1000	0.25	0.25
Jug	15000	0.25	0.375
Lighting – incandescent	4 x 100	3	1.2
Lighting – fluorescent	2 x 50	3.5	0.35
Stereo	100	0.75	0.075
Toaster	1000	0.2	0.2
Vacuum Cleaner	800	0.1	0.08
VCR	300	1	0.3
Washing Machine	800	0.2	0.16
Water Heater	Wood only	-	0
Water Pump	560	5	2.8
Total Rating	8.42 kW	Total Daily Demand	13 kWh

(Source: Weiss, 1992)

2.4.3 Solar Energy

2.4.3.1 Available Resource

The solar resource available on the Earth's surface is dependent on a variety of factors. These include the incident angle of the sun's rays, the height of atmosphere the rays pass through, and the quality of that atmosphere (Yeaman, 1998). Riordan, (1995) stated that the solar resource varies in the following ways:

- spatial variability - latitude and altitude;
- temporal variability - time of day and time of year;
- spectral variability - variation of solar radiation spectrum as a result of changes in atmospheric conditions.

This resource is characterised by daily solar irradiance (or insolation) which is given in Wh/m² of surface area. Irradiance can be measured with a solarimeter - a device that measures the amount of energy available from the sun at a given location. In New Zealand, the Meteorological Service records global radiation and sunshine hours at some of its recording stations. These can then be converted to direct (i.e. solar radiation coming directly from the sun) and diffuse (i.e. radiation that has been scattered and reflected in the atmosphere) forms of radiation using a number of computer models. If sunshine hours are the only information available there are also a number of models which convert this information to global radiation (Yeaman, 1998).

2.4.3.2 Energy from the Sun

Electricity is generated from the sun by a phenomenon known as the photovoltaic effect, which occurs when radiant energy falls on a photovoltaic cell consisting of two thin layers of semiconductor material. The flow of electrons between these two layers provides an electric current, which can be used to power appliances or charge a battery.

The two semiconductor layers are usually made of silicon with different impurities being added to each layer to change their molecular structure. One layer of silicon is doped with phosphorus, which enables an electron from each atom to more easily detach and become free to move within the silicon layer (known as an *n*-type layer). The other layer is doped with boron, which creates electron 'holes' that require an electron to fill them (known as a *p*-type layer) (Dunn, 1986).

When photons of light hit the junction between these two layers their energy is transferred to the material and creates more electron/hole pairs which are free to move within the material. The electrons are moved to the *n*-type layer and the holes are moved to the *p*-type layer (Figure 2.6). If an external connection is made between these two layers, the free electrons pass through the connection in the useful form of an electric current.

Figure 2.6: The photovoltaic effect in a silicon cell

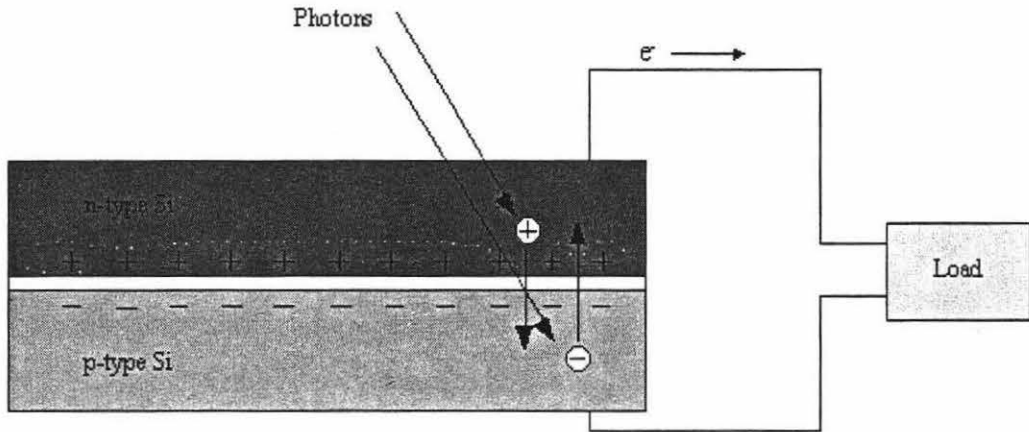

(Source: HSW, 2000)

2.4.3.3 Types of Solar Cell

Solar cells are categorised according to their materials and structure. They can be broadly categorised into the silicon group, which are based on silicon materials, and the compound group, which are based on compound-semiconductor materials (NEDO, 1999).

The silicon group is subdivided into:

- Monocrystalline - thin wafers cut from a large single silicon crystal to form the individual cells. These cells have the efficiencies between 19 and 23%, but also have the highest cost;
- Polycrystalline - thin wafers are cut from a large multiple crystal silicon block to form the cells. These cells are most commonly used in remote area power supply systems. The typical efficiency of this type of cell is between 12 – 14% (Solarex, 1999);
- Amorphous – have a non-crystalline structure with an efficiency of 6% (Corkish, 1997). These are the cheapest solar cells due to their low costs of production (NEDO, 1999) and are commonly used in calculators and watches.

Cells in the compound group are typically produced from Gallium Arsenide (GaAs), and Aluminium Gallium Arsenide (AlGaAs). These cells have efficiencies between 19 and 23% (Fraunhofer ISE, 2000).

Solar cells are rated in Watts, measured under Standard Test Conditions (STC) (Gray, 1996). The output of a solar panel varies with temperature and irradiance, so this standardisation makes direct comparisons between models possible. The Standard Test Conditions are: irradiance = 1000 W/m²

temperature = 25⁰C

2.4.3.4 Potential Environmental Impacts

Solar electric generation is an inherently clean source of electricity. Once constructed, PV cells produce no noise, acid rain, smog, carbon dioxide, water pollutants or nuclear wastes (Golob and Bruce, 1993). However, the process of producing solar cells uses toxic chemicals, such as cadmium and arsenic. If the processes are managed properly the environmental impacts of production are considered to be small. The disposal of cells when they reach the end of their useful life also needs to be considered. The energy required for the production of PV arrays is another consideration, as the process is energy intensive. However, PV cells are considered to 'pay back' the energy required to produce them in 1.6 to 2.7 years for polycrystalline cells and 0.9 to 1.6 years for amorphous cells (Corkish, 1997).

Unless large scale power plants are being considered, electricity generation from solar cells requires no use of land, as the cells can be mounted on existing buildings.

2.4.4 Wind Energy

2.4.4.1 Available Resource

The ideal site for wind generation is one where the wind is "clean", with little or no turbulence. Turbulence can significantly reduce the power output of a turbine (Weiss, 1992), and shorten its life expectancy. The following landforms are well known for producing clean, high velocity wind:

1. gaps, passes and gorges;
2. long valleys extending down from mountain ranges;
3. high elevation plains;
4. exposed ridges, hills and mountain summits;
5. exposed coastal sites (Vosburgh, 1983).

2.4.4.1.1 Overcoming Turbulence

Through good site selection the effects of turbulence can be minimised, but the factor which makes the biggest difference is the height of the turbine tower (Gray, 1996). Edwards (1986) gave three useful guidelines for avoiding the effects of turbulence. The turbine should be sited so that it is:

1. upwind a distance of at least 2 times the upwind barrier height;
2. downwind a distance of at least 10 times the downwind barrier height;
3. downwind a height of at least twice the downwind barrier height.

Gray (1996) stated that the ideal situation is to have ground clear of minor obstructions (such as trees and buildings) for 100m in all directions from the turbine, and clear from major obstructions (such as sudden changes in landform) for 200m. He also recommended that the minimum tower height should be 12m, even on clear ground.

Some examples of situations where turbulence occurs are shown in Figure 2.7. They also show how correct sizing of the tower can reduce the effects of turbulence.

Figure 2.7: The effects of wind turbulence over various land forms

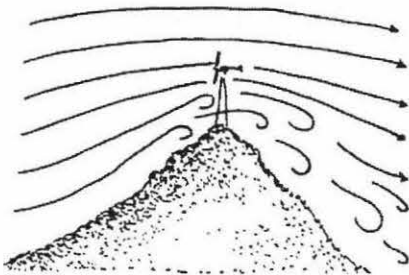

The proper height and location for a turbine on a hill. It can harness the high speed winds, but is above the turbulence.



The trees here will cause turbulence. A taller tower is required close to the trees to avoid the turbulence, but a smaller tower is sufficient away from the trees.

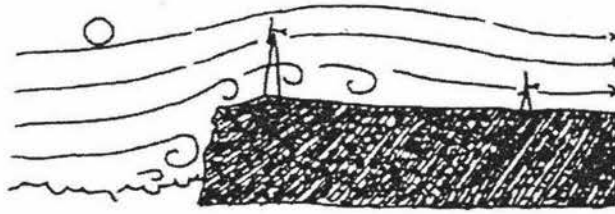

Strong turbulence occurs near cliffs. A tall tower is required near the cliff, but a shorter tower is adequate if placed far enough away from the cliff.

(Source: Gray, 1996)

2.4.4.1.2 Determining Wind Speed

Wind speed is the prime consideration in the accurate assessment of wind generation potential (Weiss, 1992). There are a number of options available for assessing this resource:

- obtain wind velocity data from meteorological records. These can be sourced from the New Zealand Meteorological Service, universities, airports and existing wind turbine owners (Weiss, 1992). Care needs to be taken in extrapolating data from existing sites to a proposed turbine site nearby as small variations in terrain can have significant impacts on wind characteristics;
- measure wind speed with an anemometer (Gray, 1996). These can vary from expensive versions connected to dataloggers for regular accurate readings, to small hand held devices for one off readings;
- measure wind speed with an odometer (or accumulator) (Weiss, 1992). This simply records the number of revolutions the anemometer makes as a distance figure, known as wind run. The average wind speed is then found by dividing the distance by the time over which the recordings were taken.

2.4.4.2 Energy from the Wind

Energy in the wind is in the kinetic form, or the energy of motion. A wind turbine harnesses some of this kinetic energy and transforms it into mechanical and then electrical energy.

The equation for determining the power available from a wind turbine is:

$$P/A = 0.5 \rho v^3 \quad \text{Equation 2.1}$$

where P = power (watts)
 A = area (m^2)
 ρ = Density of air
 v = velocity of air flow (m/s)

From Equation 2.1 it can be seen that the available power is highly dependent on the wind velocity, as the relationship between specific power and air velocity is cubic (Figure 2.8).

Figure 2.8: The relationship between wind speed and the specific power output of a turbine

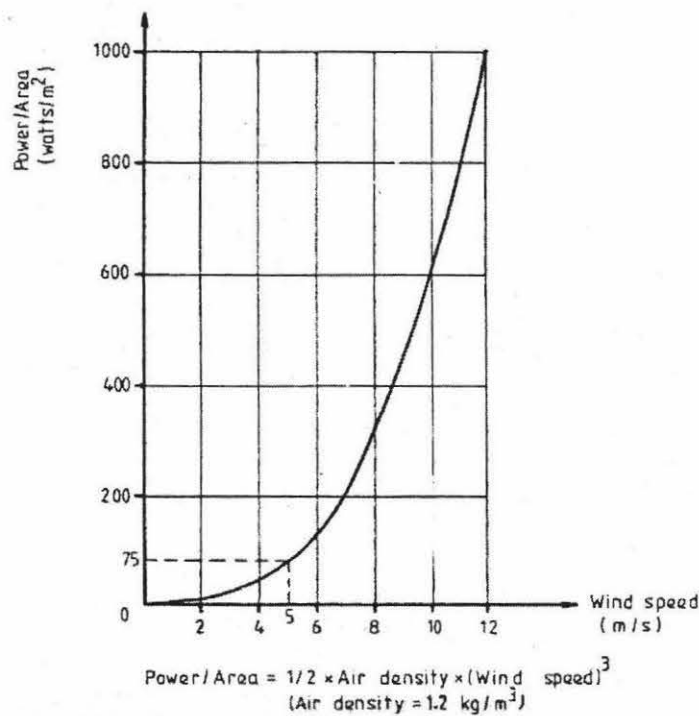

(Source: Dunn, 1986)

Not all the energy available in the wind can be extracted, as this would result in the wind velocity being reduced to zero behind the turbine. The power output for a specific turbine is usually provided with the manufacturer's specifications (Figure 2.9). The power curve shown is taken from the specifications for a Windflow 500kW wind turbine.

Figure 2.9: The power curve of a Windflow 500kW wind turbine

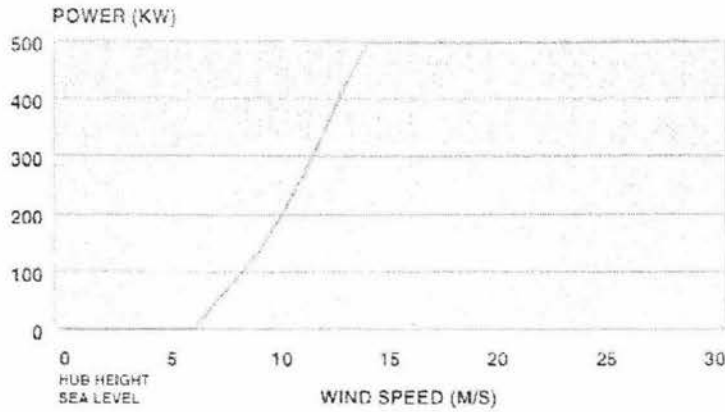

2.4.4.3 Types of Wind Turbines

There are two basic types of wind turbine used today: vertical axis and horizontal axis. Figure 2.10 shows some of the variations of turbine design that exist within these two categories. Only two or three bladed horizontal axis turbines are commonly used for smaller scale applications today.

Figure 2.10: Types of wind turbine

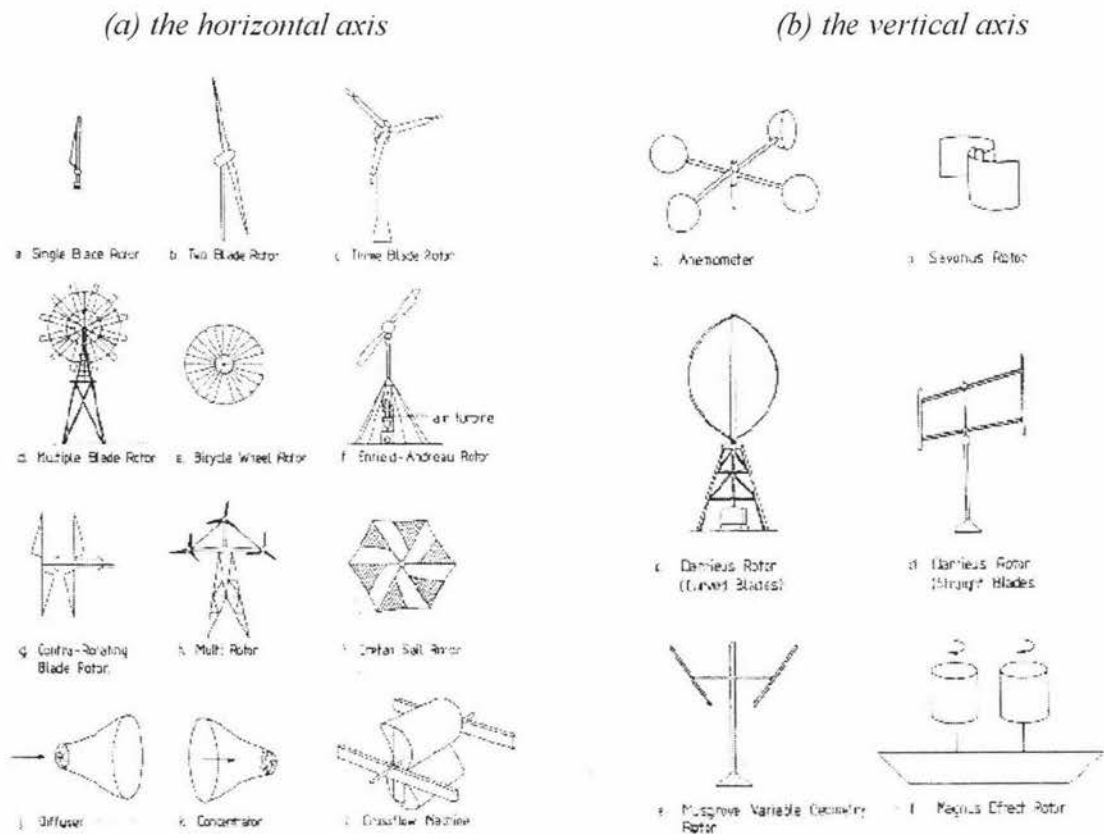

2.4.4.4 Potential Environmental Impacts

As with solar generation, wind energy is considered to be a particularly 'green' generation source because it consumes no fuel and produces no emissions. The turbine manufacturing process has very little impact on the environment in comparison to the production of solar cells. However, the location and operation of a wind turbine can have a number of environmental impacts. These are:

- disruption of natural habitats around the wind generator sites, due to grading land, laying foundations, and building service roads. These impacts are associated more with large scale schemes, but small stand alone units can also cause some of these problems;
- use of land - due to the wide spacing required for wind turbines, wind farms can use up a lot of open space. However the generator towers use a very small percentage of that land, and what remains is still available for cropping or grazing purposes.
- avian mortality - the rapidly spinning blades of small wind turbines is claimed to cause problems if bird life in the area is prolific. In California, bird deaths from electrocution or collisions with spinning rotors have killed or injured more than 30 threatened golden eagles and 75 other raptors such as red-tailed hawks during a three-year period. (Brower 1992). However, the mortality rate is site-dependent, so it is suggested that turbines be sited at least 300m from nature reserves to reduce the risk of killing birds (Pimentel, 1994)
- noise - wind turbines do produce some noise, due to the rotating of their blades and the movement of gear box parts. The noise from the spinning blades is caused by wind passing over the blade surface, with most of the noise coming from the back of the blade (Windpower.dk, 1999). The design of blade surfaces and tips has improved considerably, reducing the noise from spinning blades to an acceptable level. The noise associated with small turbines is greater due to the higher tip speed that occurs with these turbines.

Mechanical noise from gearboxes and other moving parts has also been a problem. However, a survey on research and development priorities of Danish wind turbine manufacturers conducted in 1995 showed that no manufacturer considered mechanical noise to be a problem, and no further research in the area was considered necessary. This reduction in noise has been achieved through the usage

of improved materials, and designing turbines to ensure that the vibrations of different components do not interact to amplify noise (Windpower.dk, 1999)

Proper siting of turbines can minimise the effects of noise, with the distance from dwellings being an important factor (Golob and Bruce, 1993).

- visual impact - this is the most common objection held against wind turbines. Large towers and turning rotors have been considered by some to be unsightly and detracting from the natural look of landscapes. However, an opinion poll carried out in California found strong public support for wind turbines, even from those who lived close to the turbines themselves (Golob and Bruce, 1993). Some of the methods available for minimising the visual impacts are to install turbines of uniform design, colour and rotation direction.

2.4.5 Micro-hydro Energy

2.4.5.1 Available Resource

There are two major factors to consider when looking at the potential of a hydro resource. The first is the flow rate in the watercourse and the second is the head (or difference in elevation between the intake and outlet) available at the site. The various methods for measuring these values are given below.

2.4.5.1.1 Determining Flow-rate

Both Weiss (1992) and Gray (1996) provided valuable overviews of the various methods used to determine flow rate. A summary of these is given below.

- Weirs: A weir is a small version of a dam, but with a notch of known dimensions cut into the top of it. Typical notch shapes are rectangles, triangles or trapezoids. A weir should be installed at right angles to the stream flow. The crest of the notch should be sharp for more accurate results and preferably constructed from metal. Most temporary weirs are made with wood and use plastic sheeting to prevent leaks.

Once the weir is in place, the depth of water above the crest of the weir is recorded and then converted to a flow rate using standard equations for the notch shape. This depth can either be measured visually at regular intervals, or with data logging

equipment which records the information electronically over time to determine flow rate changes due to rainfall events.

- Float Method: this is less accurate than the weir method, but it does enable a quick estimate of flow rate to be made. The procedure is as follows (Gray, 1996)
 1. mark a board at 0.5m intervals and place it across the stream (Figure 2.11);
 2. record the depth of the stream at each mark;
 3. multiply the depth at each mark by 0.5m to give an area of that part of the stream, then add all the sections together;
 4. record the time it takes for a float (polystyrene, wood) to travel a certain distance downstream. Ensure the velocity through the section of river being measured is reasonably uniform;
 5. multiply the velocity by the area and a correction factor to give the flow rate. This correction factor takes into account differences in velocity due to variations in the surface of the stream bed. See Table 2.2 for the correction factors.

Figure 2.11: The float method of measuring flow

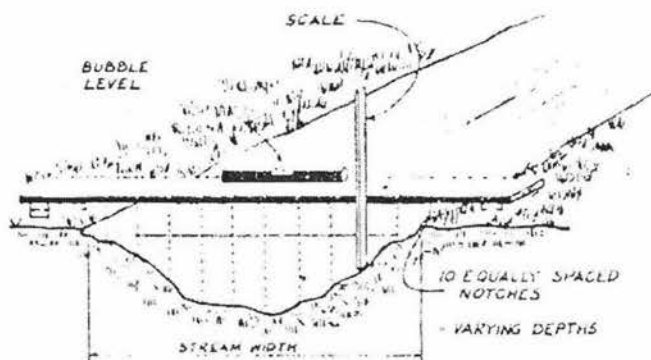

(Source: Ministry of Energy, 1986)

Table 2.2: Correction factors for the float method of determining stream flow rate

Stream Type	Correction Factor
Large, slow, clear stream ($>10\text{m}^2$)	0.75
Small, slow, clear stream ($<10\text{m}^2$)	0.65
Shallow ($<0.5\text{m}^2$) turbulent stream	0.45
Very shallow ($<0.2\text{m}^2$) turbulent stream	0.25

(Source: Gray, 1996)

Bucket Method: this can be used for very small streams where the flow can be diverted into a bucket of known volume and the time is recorded for the bucket to fill. The flow rate can then be calculated by dividing the bucket volume by the time taken to fill it.

2.4.5.1.2 *Determining the Available Head*

Accuracy is critical when it comes to measuring the available head, especially when the head is small (< 10metres). The various methods are:

- Surveyors' level (theodolite): gives the most accurate results, but require a degree of skill in their use, and also become difficult to use when the area is heavily vegetated (Gray, 1996);
- Sighting meter or inclinometer: measures the angle from the bottom to the top of the stream section that will be used for the micro-hydro scheme, and combined with a knowledge of the horizontal distance between the two points can give the available head;
- Altimeter: measures air pressure and converts the pressure difference to height. The time between readings at the top and bottom of the slope needs to be minimised as changes in temperature and weather conditions can reduce the accuracy;
- Water filled tube and pressure gauge: a less accurate method that uses a pipe inserted into the water source and a pressure gauge at the other end to measure the pressure. This procedure is continued along the length of the stream until the proposed turbine location is reached, with the total head measurement being equal to the sum of all the readings taken (Weiss, 1992).

2.4.5.2 *Power from Streams*

The power output is dependent on the flow rate of the water and the head (Equation 2.2).

$$P = e g Q H \qquad \text{Equation 2.2}$$

- where
- P = available power (Watts)
 - e = turbine efficiency (e.g. 0.9)
 - g = acceleration due to gravity - 9.81m/s²
 - Q = flow rate of stream (m³/s)
 - H = available head (m)

2.4.5.3 Types of Turbine

In large scale electricity generation three types of turbines are used - the Pelton, Francis or Kaplan. In smaller scale applications the most common turbines are Turgo, Crossflow and Pelton turbines. These turbines are generally known as 'impulse turbines' and are rotated by high pressure water being forced onto the turbine bucket or blades (Gray, 1996).

The selection of the appropriate turbine for the head and flow conditions at a site is an important one as some turbines are better suited to particular applications than others (Figure 2.12 and Figure 2.13).

Figure 2.12: Turbine selection chart for flows less than 200l/s

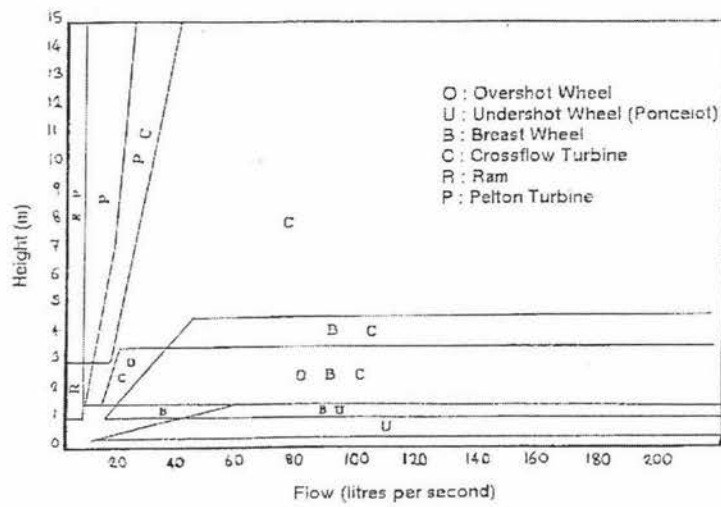

(Source: Dakers and Martin, 1982)

Figure 2.13: Turbine selection chart for flows up to 10,000l/s

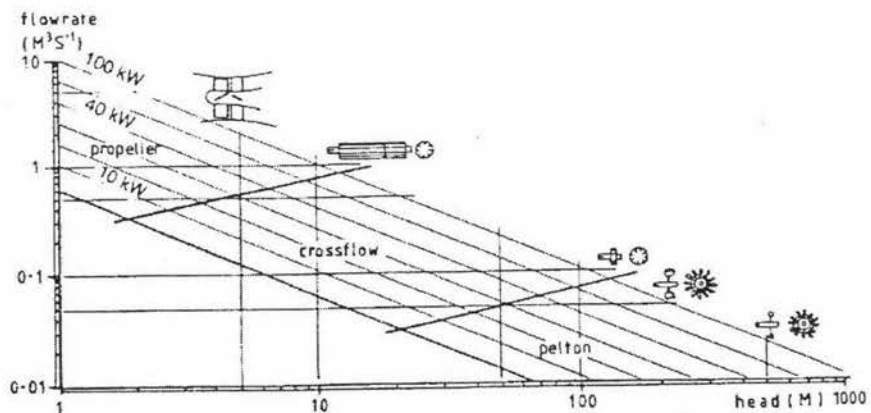

(Source: Hothersall, 1984)

2.4.5.4 Potential Environmental Impacts

The impacts associated with micro-hydro generating schemes are dependent on the site and setup of the scheme. One of the critical factors is the percentage of total available water in the stream being diverted to generate power, along with information indicating how and when that water is taken from the river. In an investigation of a micro-hydro scheme in the King Country, Bowley (1996) stated the anticipated environmental impacts as being:

- visual, due to construction of a weir and the generator itself;
- disruption of eco-systems. This is particularly relevant when a large percentage of available water is taken from the streambed. Lower water levels can impact on species downstream of the intake point, and weirs can exclude some fish species from travelling upstream past the weir site;
- construction of earth works;
- dam breaks - if the stream is dammed at the intake point, this raises the possibility of the dam breaking, causing a flash flood. If correct engineering assessments and design are made the chances of this occurrence are minimal.

2.4.6 Power Management - Storage, Regulation and Inverting

Equipment is required to take the electricity from the generating source to the point of use and involves storage, regulation and inversion from DC to AC electricity.

2.4.6.1 Storage

Renewable energy systems need to have some form of energy storage if they are to meet the required demand profile. This is particularly important if intermittent generating sources such as solar or wind are being used. Hydro provides a constant supply of energy, but if too much is produced it must be dumped. This is usually achieved with a heating element used to heat air or water. If energy produced at times of low demand can be stored for later use this minimises the capacity of the generating equipment and the need for back up generation. Gray (1996) recommends that energy storage for three to five days should be provided to give adequate cover for times of calm wind and cloudy conditions.

The most common form of energy storage is the battery. Two types are used for renewable energy applications: deep cycle lead-acid and ni-cad.

- Lead acid batteries are the most common, and are used for 99% of solar and backup power systems (NAWS, 1999). These batteries have electrodes of metallic lead, and use sulphuric acid for the electrolyte. Typical life expectancies are about 6 to 10 years. The lead acid battery can be recycled after use.
- Ni-Cad alkaline batteries use nickel oxide in the positive terminal and cadmium in the negative terminal. They have some good features that distinguish them from lead acid batteries, (e.g. low self discharge, non-freezing); but they are also more expensive to purchase and dispose of, as Cadmium is a very hazardous chemical. They are well suited to emergency / standby applications as they have a longer chronological life, but shorter cycling life in comparison to lead acid batteries (NAWS, 1999).

Batteries need to be well maintained to maximise their useful life, and one of the keys to doing this is preventing the batteries from discharging to less than 50% of their capacity (Gray, 1996).

2.4.6.1.1 Sizing the Battery Bank

The capacity of the battery bank can be found by dividing the number of Watt-hours required by the battery voltage. For the load analysis shown in Table 2.1, the required Amphour capacity for a 24V battery to supply 13 kWh/day would be:

$$\frac{13,000 \text{ Wh/day}}{24\text{V}} = 541 \text{ Ah/day}$$

If 5 days supply were to be stored in the batteries, the total required capacity would be:

$$541 \text{ Ah/day} \times 5 \text{ days} = 2708 \text{ Ah.}$$

Batteries have typical efficiencies between 85% to 90% (Gray, 1996) so the capacity calculated above must be divided by the efficiency to give the true capacity.

$$2708 \text{ Ah}/0.85 = 3186 \text{ Ah.}$$

2.4.6.2 Regulation

The batteries in a renewable energy system are sensitive to overcharging as well as excessive discharging (Yeaman, 1998). This means that the energy entering the batteries must be controlled to ensure that overcharging does not occur. This is done with a regulator which manages the battery voltage and stops excess energy entering the batteries. Once the batteries are fully charged, excess energy is diverted to a dump load where it is consumed.

2.4.6.3 Inverters

Most wind and micro-hydro generators on the market today produce AC power, but solar panels will only produce DC power (Yeaman, 1998). Batteries also only store electricity in DC form. If this DC power is to be converted to AC electricity for use with most modern appliances an inverter is required. Inverters come in three different types, with their wave forms shown in Figure 2.14:

1. sine wave - convert low voltage DC electricity to 230V AC electricity - a form most similar to mains power. They are the most expensive type of inverter as they are the most complicated. Many of today's electronic appliances and computers require a very clean sine wave to operate properly.
2. square wave - provide a square wave AC supply, instead of a sine wave, but they nevertheless provide a reliable electricity supply to most appliances. Some appliances will not operate perfectly on electricity generated from these inverters, but they are much cheaper than sine wave inverters (Gray, 1996).
3. modified square wave - these inverters fall between the first two types and give a closer approximation to the true sine wave. They may still cause minor problems with some appliances.

Figure 2.14: Inverter wave forms

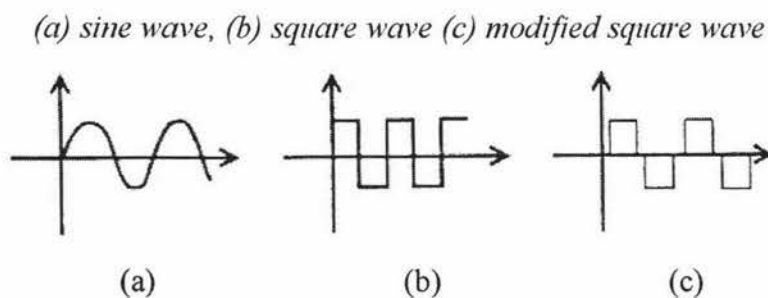

(Source: Gray, 1996)

3 Case Study Site Description

Three case study sites were investigated in this study with each site differing from the others in a number of ways, so that experience could be gained and applied to a variety of situations in the future. The physical nature of each of the communities is described below.

3.1 Case Study Community 1 – Totara Valley

The first case study site was the community of residents in the Totara Valley, east of Woodville. The community was identified as a potential monitoring site when a member expressed an interest in investigating renewable energy options for their farm.

3.1.1 Reasons for Inclusion in the Study

A common feature of rural New Zealand is a community of farming properties contained within a river valley remote from main urban centres. Totara Valley is an example of this feature which made it an ideal case study as the lessons learnt can be applied to many similar sites around the country.

Many rural communities consist solely of farming families with little or no population variation throughout the year. Four families reside in the Totara valley, with a total population of 14. This case study site was the only one of the three not to have some form of holiday accommodation or tourist operation which would result in seasonal variations in population and electricity consumption.

This site also has the potential to use all three forms of energy being considered in this study.

3.1.2 Location

The Totara Valley is located behind the township of Kumeroa, 24 km to the east of Woodville and the Manawatu Gorge. The valley runs in a northwest - southeast direction and is approximately 17km long, from the head of the valley to “Aotatara”, where Totara Road begins. The Totara Stream which flows down the valley is a

tributary to the Manawatu River. The topography of valley and the location of buildings is shown in Figure 3.1.

Figure 3.1: Topographic map of the Totara Valley

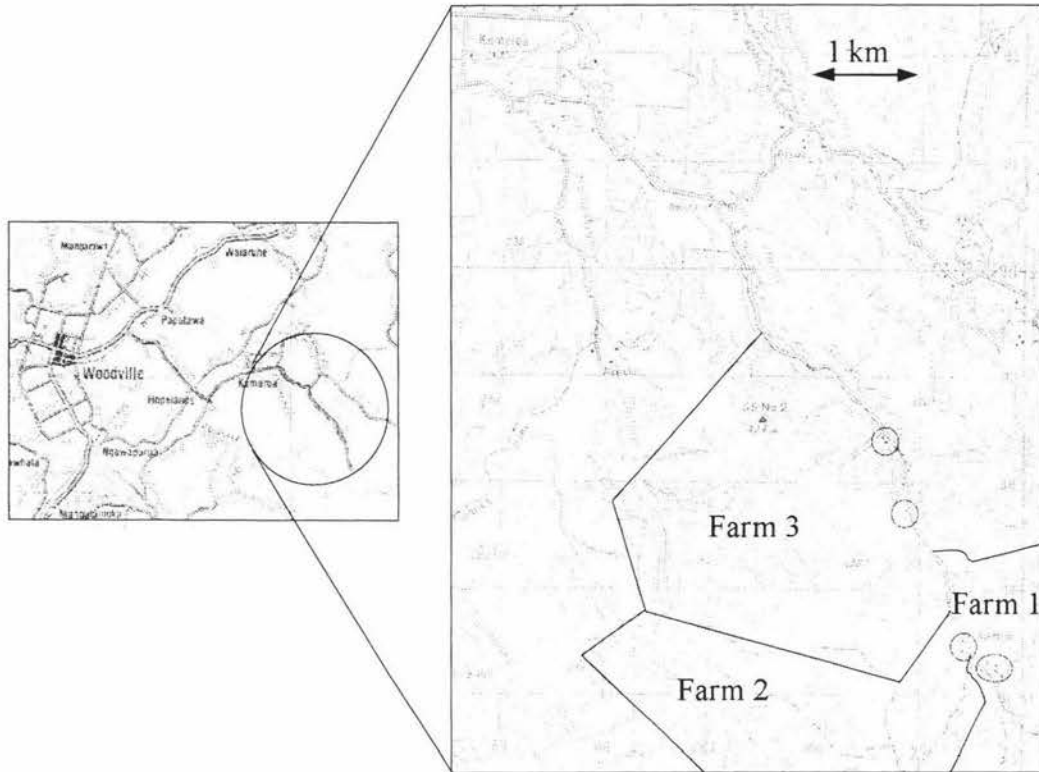

The Totara Stream and its tributaries have shaped the topography of the valley. The stream flows the length of the valley in a well developed channel. The valley floor is narrow (300m to 400 m along most of its length), with steep hill country on both sides. The head of the valley has a coquina limestone base, with many small outcrops and springs. There are no surface water features at the lower end of the valley due to the high permeability of its marine sand and silt base.

3.1.3 Properties

The head of the valley consists of one farm, with the farm buildings located at the road end. This farm is the largest in the valley with an area of 971 hectares. The neighbouring farm of 640 hectares is located on the western side of the valley with its buildings located 200m from the first farm. A third farm of 600 hectares is also located on the western side of the valley, with the main residence 1.5km from the road end, and the farm sheds and manager's cottage 2.5km from the road end.

3.2 Case Study Community 2 – D'Urville Island

The second case study site to be identified was the community of residents living on D'Urville Island, in the Marlborough Sounds of the South Island. Some residents had been considering the use of renewable energy sources before this study began, but the willingness of other community members to be involved was unknown. A meeting of the D'Urville Island Association was held at Kupe Bay on 07/11/1998 to seek the support of the whole community. The meeting was chaired by the chairperson of the D'Urville Island Association, and was attended by 50% of the island's residents. The decision of the association was to support the study by offering access to their land, and providing accommodation and transport where possible.

3.2.1 Reasons for Inclusion in the Study

D'Urville Island's was included in the study for its remote location. The nearest populated town is Blenheim, 100km away. Access is by boat only, with a 10 minute crossing of French Pass required. There is a gravel road over most of the island connecting the larger properties, but some properties at the southern end can only be accessed by boat.

Most of the island is steep country, with native bush covering the central third. Maintaining a grid connection on this terrain is expensive, making it susceptible to decommissioning in 2013.

There is approximately 60km of power line on the island to supply the 10 grid connected properties inhabited by permanent residents. This low population density makes it different from the more closely populated Totara Valley site.

A wide range of income sources including farming, fishing, and tourist accommodation result in a seasonal variation in power consumption. This is partly due to a significant population fluctuation, with an associated increase in electricity consumption over the summer months.

3.2.2 Location

D'Urville Island is the northernmost point of the South Island, situated 50km north of the Rai Valley township. French Pass, a narrow stretch of water with a very fast tidal current, separates the island from the mainland. Access to the island is gained from Kapowai, from where a public road winds its way to most of the properties on the island and the permanent residents located on the island (Figure 3.2).

Figure 3.2: Map of D'Urville Island showing location of permanent residents

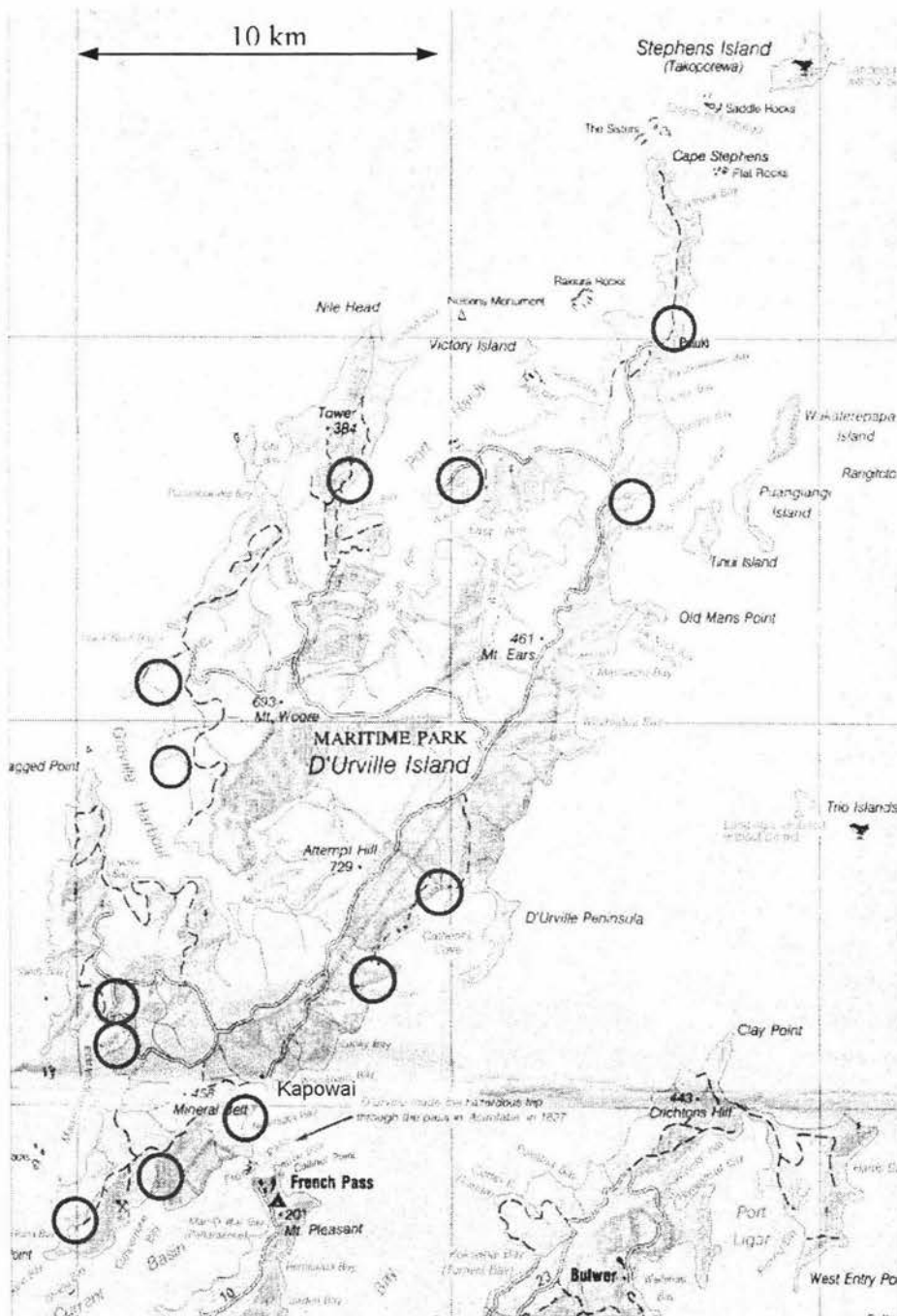

3.2.3 Topography and Geology

D'Urville Island was once completely covered in native bush, but sections of the island are now cleared for farming. The island is predominantly hilly, with a gradient between 15° and 25°. The terrain is rugged with numerous rock outcrops. Sea cliffs up to 100m high dominate the western coastline.

3.2.4 Population

There are 13 properties spread around the island which are permanently occupied, with all residents living on the coastline (refer Figure 3.2). There are also approximately 20 holiday homes around the island, resulting in a large population growth over the summer period.

There is one commercial accommodation business in Catherine Cove. The D'Urville Island Wilderness Resort has four self contained units, with a beachfront café and bar. This attracts visitors all year round, with the Christmas/New year period being the busiest. A community hall is located on the roadside in the middle of the island and is the only building located away from the coastline.

3.2.5 Existing Community Structure

A community association for all residents and landowners has been established on the island. The association holds a meeting once every four months to discuss issues relating to the community. Of all the case study communities they appeared to be the most well organised in terms of working together for the common good.

3.3 Case Study Community 3 – Akitio

Akitio is a small village in the Wairarapa, on the east coast of the North Island. The village is situated directly east of Eketahuna on the mouth of the Akitio River, which flows into the Pacific Ocean.

3.3.1 Reasons for Inclusion in the Study

Akitio was included in the study for its remote location, being 30km from the closest small village of Pongaroa. It is also located at the end of a long power line, with very few customers connected between Akitio and Pongaroa.

Massey University had been monitoring wind speeds on a nearby farm for the previous year, and the average windspeed for the site was over 10ms^{-1} , which is similar to that at the Tararua Wind Farm in Palmerston North.

The pricing structure of Central Power, the lines company which supplies the district is a graduated tariff where customers who live in Palmerston North pay half as much for their connections as those at the extremities of their distribution network. This high daily network charge is a significant cost to holiday homeowners who only use their properties for a few weeks of the year.

There are very few farms in Akitio, with most people owning a house on a small section. This means that a much wider range of income sources is represented, and the population density is greater than the other case studies.

3.3.2 Topography

Akitio is mostly located on a narrow strip of flat land between the beach and the hills behind. The surrounding country consists of steep rolling hills, reaching up to 300m behind the village. Most of this land is used for farming or forestry, with very little native bush remaining. The village faces directly east, and is exposed to strong on shore winds.

Figure 3.3: Topographic map of Akitio

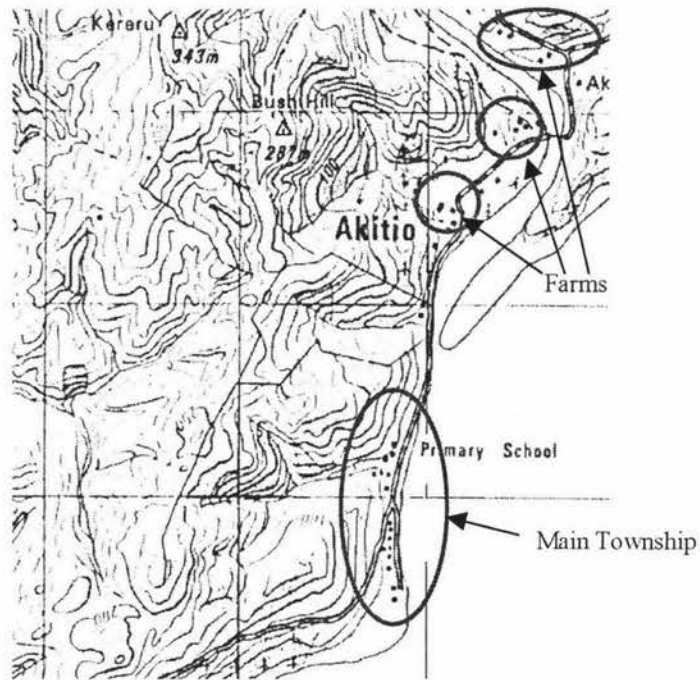

3.3.3 Population

The population of Akitio consists of permanent residents, and holiday home owners who use their houses occasionally during the year. Approximately half the properties are owned by permanent residents, so population fluctuations are large. The busiest week of the year is between Christmas and New Year, when the population is often triple the usual number.

3.3.4 Properties

The main township of Akitio is located 1km south of the Akitio River mouth. There are three farms associated with the village which are all situated on the banks of the Akitio River. All the farms have a large homestead, with two or three farm labourers' houses belonging to each farm.

3.3.5 Income Sources

The income sources of Akitio landowners are varied. The village was once a thriving fishing village, but only one person makes a living from fishing today. The occupations of the residents include teaching, retailing, tourist accommodation, and farming. There are also a number of retired people living in the village.

4 Household Questionnaire

A questionnaire was used to determine the case study site residents' electricity demand and attitudes towards a community owned renewable energy scheme. The process used to design and administer the questionnaire is summarised, along with the results. A copy of the final questionnaire and covering letter is included as Appendix B.

4.1 Questionnaire Sample

For each of the three case study communities discussed in Section 3 the goal was to achieve 100% coverage of the population. This was considered necessary, as any community owned scheme would affect all landowners. The population for each community was defined as:

“all citizens who live in, or own property in, the case study community”.

The method used to determine the population members was different for each community as each case study site had its own difficulties.

4.1.1 Totara Valley

The population of Totara Valley was easily defined due to its small size. Six separate households were initially identified, however the geographical split of these into two distinct groups meant that the population for this study was reduced to the four households at the head of the valley.

4.1.2 D'Urville Island

Contact details for D'Urville Island property owners were more difficult to obtain. The best source of information available was the permanent residents. A community member provided a list of all the landowners that they could identify, but did not identify all the holiday home owners.

4.1.3 Akitio

The population of the Akitio community was the most difficult to define as the only available list of community members was the volunteer fire brigade list. A list of property owners was sought from the Tararua District Council, but due to the

restrictions of the Privacy Act they were unable to assist. The fire brigade list did not give a complete representation of the community and it only covered those who lived there permanently. Local residents estimated that property owners were about 50% permanent and 50% non-resident, which meant that the initial fire brigade list covered a maximum of 50% of the population.

Due to this lack of information a decision was made to hand deliver the written questionnaires. Local residents identified December 26th as the one day in the year when most landowners would be in Akitio, so a visit was made on 26/12/1998 to deliver the questionnaires. This method of defining the population still had a number of weaknesses, as some properties were unoccupied and others renting properties had no contact details for the owner.

4.2 Method of Administration

A written questionnaire posted to property owners was determined to be the best option for Totara Valley and D'Urville Island, due to the low cost (relative to the alternatives of telephone and personal interviews) and the fact that it gave more time for respondents to answer some of the longer questions.

Either telephone or direct interviews would have enabled answers to be drawn out of respondents. However the remoteness of property owners' residences negated direct interviews, and some questions required the respondent to gather information themselves.

4.3 Questionnaire Design

The questionnaire contained 11 pages of questions and one page with a map of the community. A covering letter detailed the purpose of the study, how the questionnaire was to be returned, the confidentiality of the responses and details about how Massey University and Powerflow Ltd. were working together on the study. Care was taken to assure respondents that answering the questionnaire would not commit them to installing a renewable energy scheme in the future.

A large number of questions needed to be asked in relation to this study, as there has been no past research done in this area. The length of the questionnaire was identified as a problem in obtaining responses, but there was no way to avoid this without sacrificing data.

4.4 Pilot Questionnaire

A pilot questionnaire was mailed out to eight households considered to be in a similar rural situation to the households of the three case study sites. The community of Kumeroa (which is close to the Totara Valley case study site) was identified as suitable for this pilot study as it had three features similar to the case study communities:

1. distance to the nearest main township;
2. a mixture of income sources;
3. some property owners had the potential to generate electricity for the community, while others would be reliant on purchasing electricity from other community members.

A covering letter informed the recipient why the questionnaire had been sent to them and gave details on how to return the questionnaire. It also gave a brief overview of the recent changes in the electricity sector to help recipients understand that they faced a similar situation to the case study communities. A stamped and addressed reply post envelope was included with each letter.

The pilot questionnaire was mailed at the end of November 1998. As the final questionnaires had to be delivered to Akitio residents on 28/12/1998 responses were requested within two weeks. Within a week of sending out the pilot questionnaire two responses were received. None of the questionnaires were returned as "Gone – no address" or similar. There was no time to follow up those who had not responded, so only two returns were used to assess the effectiveness of the questionnaire.

The test questionnaire revealed that in its existing form some questions were open to a variety of interpretations. This prompted some minor changes in the layout and

wording of the questionnaire to give more direction to respondents and ensure the necessary questions were answered.

4.5 Final Questionnaire

The approach used to deliver and return the final questionnaires differed slightly between the case study sites.

4.5.1 Totara Valley

Questionnaires were mailed to four residents in the Totara Valley. Return envelopes were not included as the questionnaires were to be collected in person. Not all the respondents were home when the first visit was made two weeks later, so only two questionnaires were received on that trip. The remaining two were collected on a subsequent visit to the community one month after their delivery.

4.5.2 Akitio

A site visit was made to deliver the questionnaires. 60 questionnaires were delivered to the residents of houses within the community. Four were left on the steps of houses with no occupants at the time of visiting, and another five were left at the village store for residents of the new subdivision at the southern end of the beach. Three of the questionnaires left on doorsteps were returned with no response.

If the assumed population was correct this equates to 82% coverage.

A reminder was sent out to residents who had not responded on 21 January 1999. A cut-off date for questionnaire returns was set at 5 March 1999, to enable further progress to be made on the study. By the cut off date only 33% of the community had returned questionnaires, and there was still an unknown number who had not been identified due to the lack of property owner details.

4.5.3 D'Urville Island

The D'Urville Island questionnaire was both sent and returned by post. Twenty four questionnaires were mailed on 23 December 1998, and it was expected that it would

take at least a week for them to arrive on the island as this is the standard postal delivery time. It was planned that the questionnaires would arrive on the island a week before a site visit on 15 January 1999, but as the postal system was delayed over the summer holiday period most residents received their questionnaires after the site visit.

12 questionnaires were returned by mail before the reminder date of 15 February 1999. As telephone numbers were available for those who had not responded, a telephone reminder was given on 2 March 1999. This reminder produced another 6 questionnaires, giving a total of 18 returns. Those who did not return a questionnaire stated during the telephone reminder that they had no interest in the study and would not be returning a questionnaire.

4.5.4 Survey Response Rate

Table 4.1 summarises the response rate to questionnaires in the three case study communities.

Table 4.1: Summary of questionnaire response rates

	Totara Valley	Akitio	D'Urville Island
No of questionnaires mailed	4	69	24
Number returned "Wrong Address" etc.	0	3	1
Number of returned questionnaires before reminder	-	21	12
Number of questionnaires returned after reminder	-	3	6
Total questionnaires returned	4	24	18
Response Rate (%)	100	34	75

A 100% response rate was achieved at Totara Valley, due to the small population size. A 75% response rate was achieved on D'Urville Island, with the remaining 25% stating that they did not want to be involved in the study. This response rate was not sufficient to achieve a 5% error at the 95% confidence interval. However, the fact that those who did not return the questionnaire stated that they did not want to be involved meant that 100% of the community did respond in some way. Akitio achieved a 34% response rate, which was also not sufficient to achieve a 5% error at the 95% confidence interval. This would have been achieved with 66 returned questionnaires. 62% of those who did respond were non-resident community members.

4.6 Results and Discussion

This section summarises the results obtained from the questionnaire. The questions regarding seasonal loads and appliance use have not been presented as they only related to the development of the computer model.

4.6.1 Totara Valley

4.6.1.1 Income Sources

Respondents were asked to identify the main source of income for the household. Three of the respondents rely solely on their sheep and beef farms for their income sources, while the other is a stock manager for one of the farm owners.

4.6.1.2 Energy Resources

Respondents were asked to identify on a map any exposed ridges or streams that flowed continuously throughout the year. All the respondents identified exposed ridges on their property that might be suitable for wind power generation. Two of the properties were identified as having streams that flowed throughout the year. This distribution of energy resources means that all the property owners would be able to contribute electricity to a community scale renewable energy scheme.

4.6.1.3 Involvement in a Community Scheme

Respondents were asked to rate their level of objection to “having a generation scheme ... installed on their property that supplies electricity to other members of the community”, as well as “using electricity that is generated on the properties of other community members” (Figure 4.1). The level of objection to providing electricity for others was lower than for having electricity supplied by other members.

Figure 4.1: Level of objection to sharing electricity with other community members

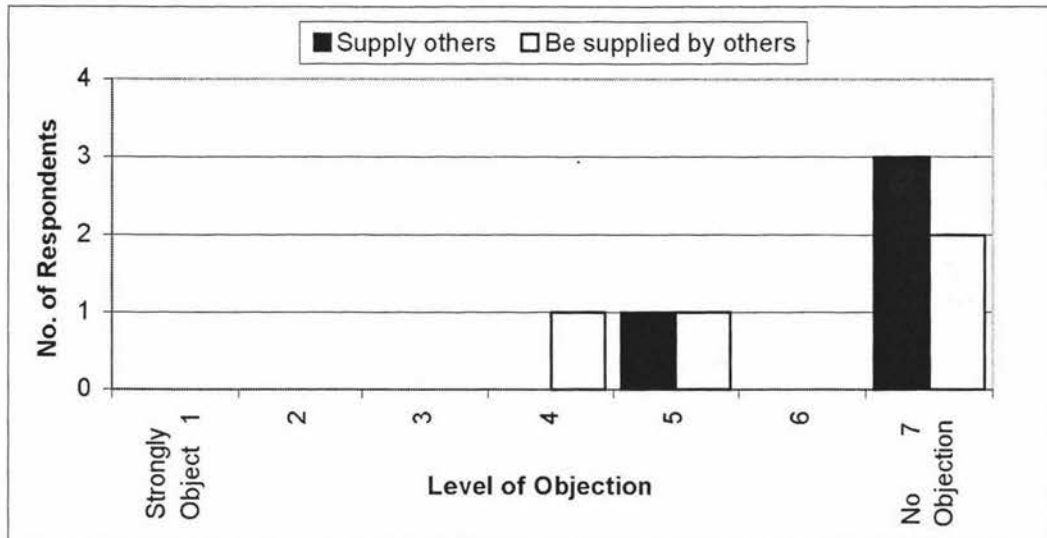

4.6.1.4 Buildings and Supply Connections

Respondents were asked how many buildings were supplied with grid electricity and how many connections supplied those buildings. The maximum ratio of buildings to connections was 1.8 with one farm having nine connected buildings and five connection points to the national grid. The minimum ratio was 1.0, with one house having just one supply connection. The higher this ratio is, the less grid connected electricity will cost as lines charges are dependent on the number of connections.

4.6.1.5 Heat Loads

Heating and cooling loads such as water heating and cooking are heavy consumers of electricity. Respondents were asked how these heat loads are currently met to determine their dependence on electricity. The only energy sources used by Totara Valley residents were electricity and wood (Figure 4.2).

Figure 4.2: Energy sources used to meet heating and cooling loads

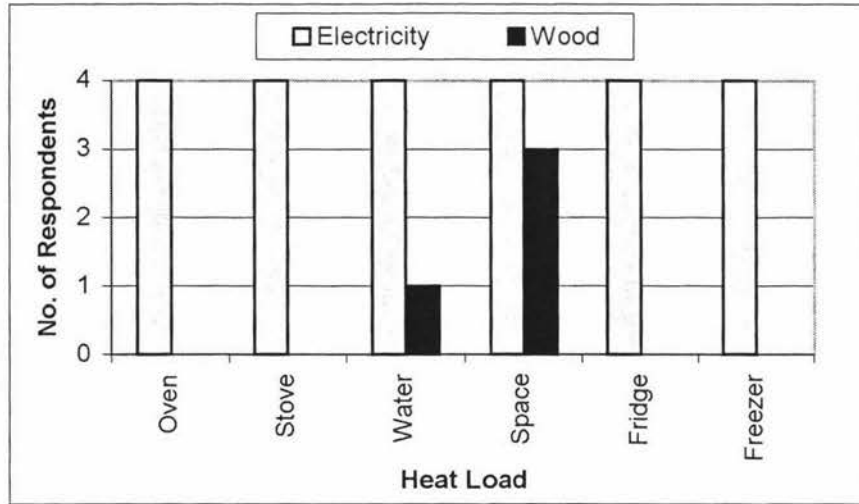

These results show a high dependency on electricity to meet heating and cooling loads. The use of alternative energy sources such as gas or wood, and the adoption of energy efficiency measures would reduce this dependency and the amount of electricity required to meet these loads.

4.6.1.6 Satisfaction With Present Electricity Supply

Respondents were asked to rate their level of satisfaction with four aspects of their present power supply on a scale of 1 to 7 (Figure 4.3). The aspects of their supply were power cuts, emergency service, rates and fluctuations in supply that caused problems with appliances. All the issues addressed relate to the service provided by the lines company (Giddens, 2000) apart from the rates, which are set by both energy and lines companies. The level of satisfaction regarding power cuts and emergency support is high throughout the population, while satisfaction with rates is generally low. Variations in supply quality appear to be an issue, but overall satisfaction in the local power supply was good.

Figure 4.3: Level of satisfaction with present supply

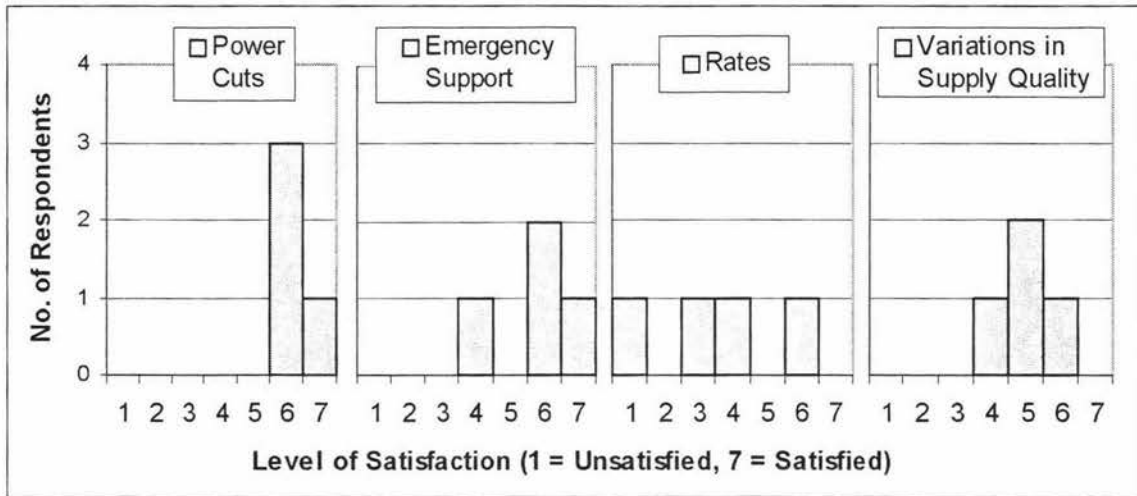

4.6.1.7 Community

The strength of the Totara Valley community was assessed using questions regarding the communities ability to work together, the respondents' trust in other members, involvement in community events, and finally the respondents' interest in being part of a community scale scheme. The results of these questions are presented in Figure 4.4 to Figure 4.7

Figure 4.4: View of how the community works together

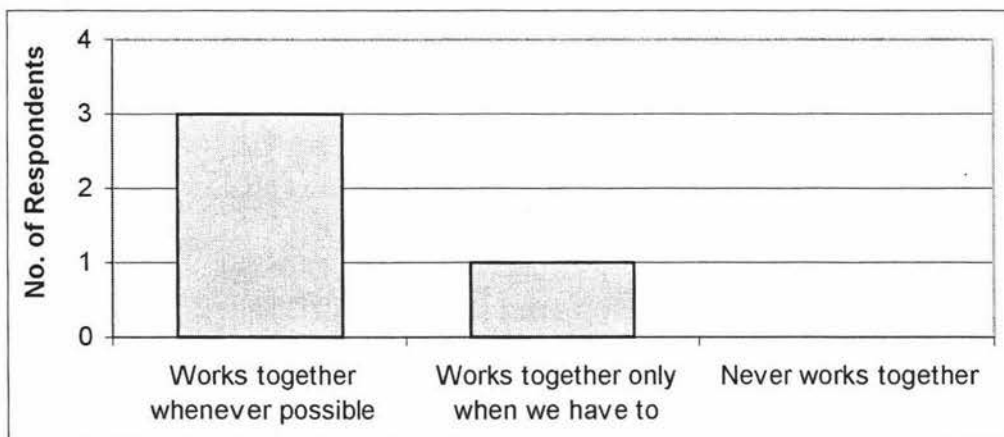

Figure 4.5: Trust of other community members

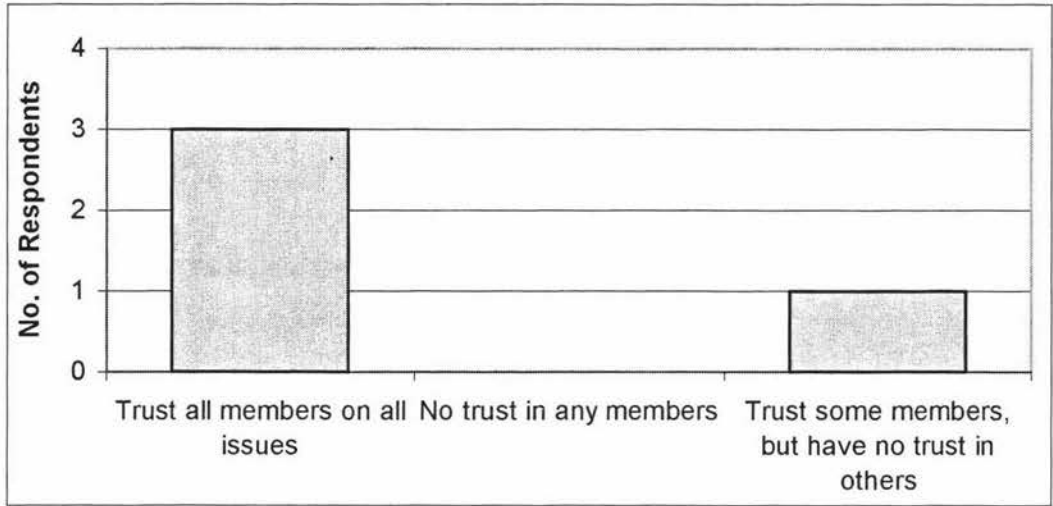

Figure 4.6: Involvement in the community through meetings and community newsletters

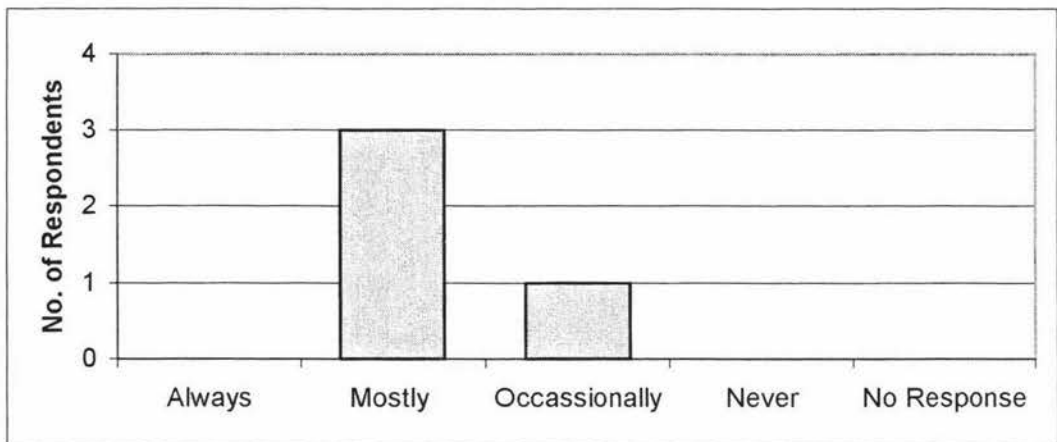
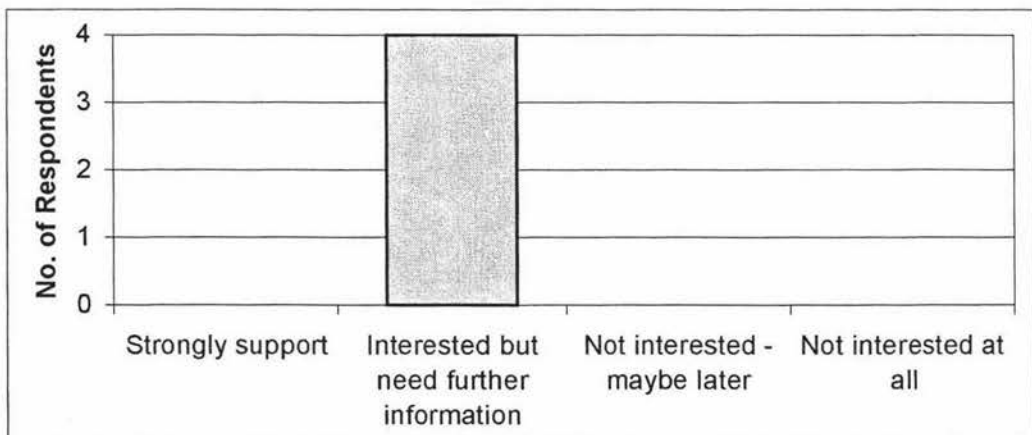

Figure 4.7: Level of support for a community owned renewable energy scheme



These results show that there is a strong sense of community amongst Totara Valley residents. The high level of trust between members and the willingness to work together would be pivotal to the success or failure of a community owned scheme. Although none of the community members strongly support the option of a community owned renewable energy scheme, they all indicated an interest.

4.6.1.8 Energy Efficiency

Totara Valley households have taken up a number of energy efficiency or substitution practices already, with gas or wood heating, ceiling insulation, and turning down the hot water thermostat being the most popular (Figure 4.8). There is also a willingness from some households to take up the practices if a renewable energy system was installed. Two households were willing to take up the use of energy efficient light bulbs, solar hot water heaters, draught stopping and hot water cylinders wraps. Two households were also willing to replace old, inefficient refrigerators and freezers.

Figure 4.8: Uptake of energy efficient practices

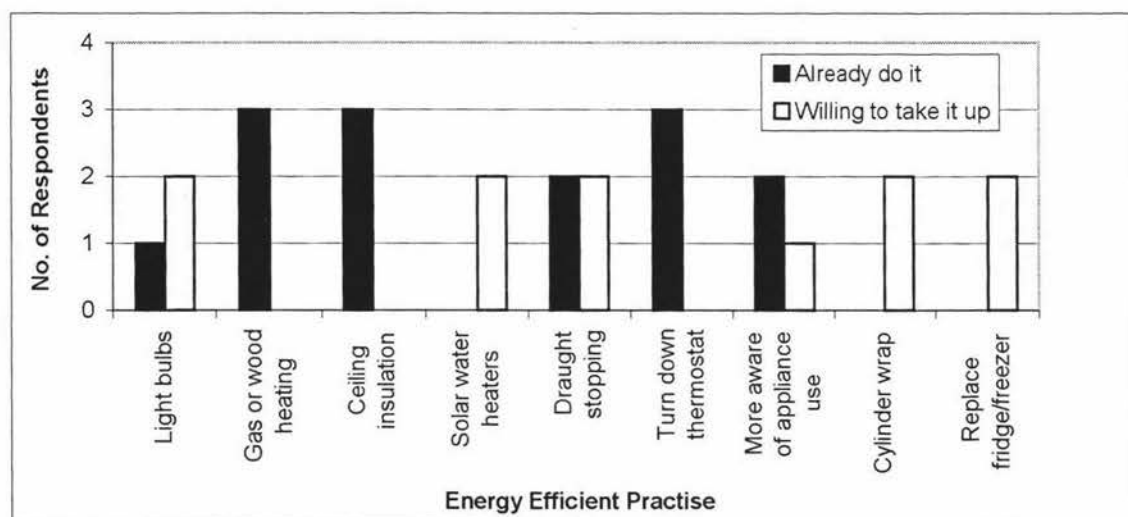

If all these practices could be taken up by members of the Totara Valley community the electricity requirements could be significantly reduced.

4.6.2 D'Urville Island

4.6.2.1 Income Sources

Income to the island comes from a variety of sources (Figure 4.9). The major source is sheep and beef farming with other sources include fishing, mussel farming, paua diving, accommodation and tourism.

Figure 4.9: Income sources for D'Urville Island

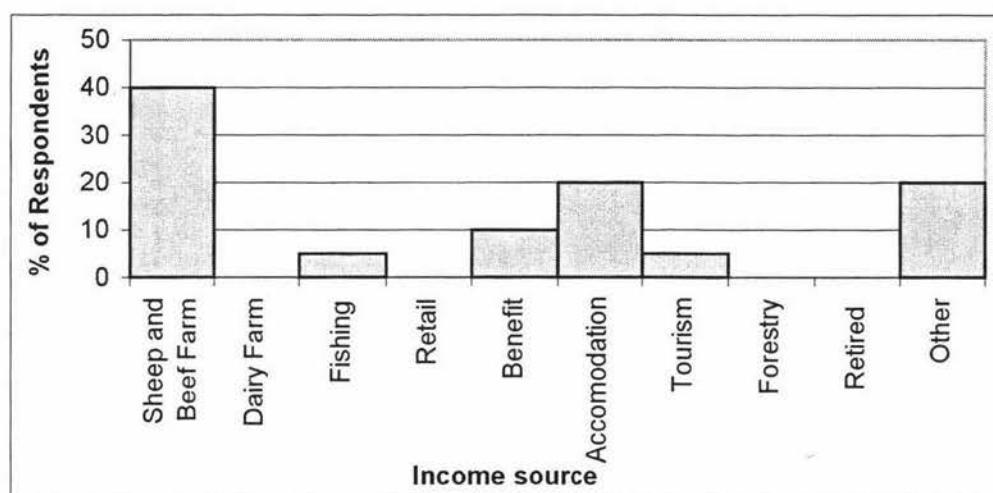

4.6.2.2 Energy Resources

Energy resources on the island are well distributed between property owners. Table 4.2 summarises the results of the question regarding the location and availability of wind and hydro resources on respondents' properties.

Table 4.2: Energy resources on D'Urville Island as identified by property owners

Resource	% of respondents that identified their property as containing the resource
Streams that flow all year	82%
Exposed windy ridges	76%
Solar	100%
No resource	0%

4.6.2.3 Involvement in a Community Scheme.

Respondents were asked to rate their level of objection to "having a generation scheme ... installed on their property that supplies electricity to other members of the

community”, as well as “using electricity that is generated on the properties of other community members” (Figure 4.10 and Figure 4.11). The results show that there is a higher level of objection supplying other community members with electricity than using electricity generated on other properties.

Figure 4.10: Level of objection to supplying other community members with electricity generated on respondents’ properties

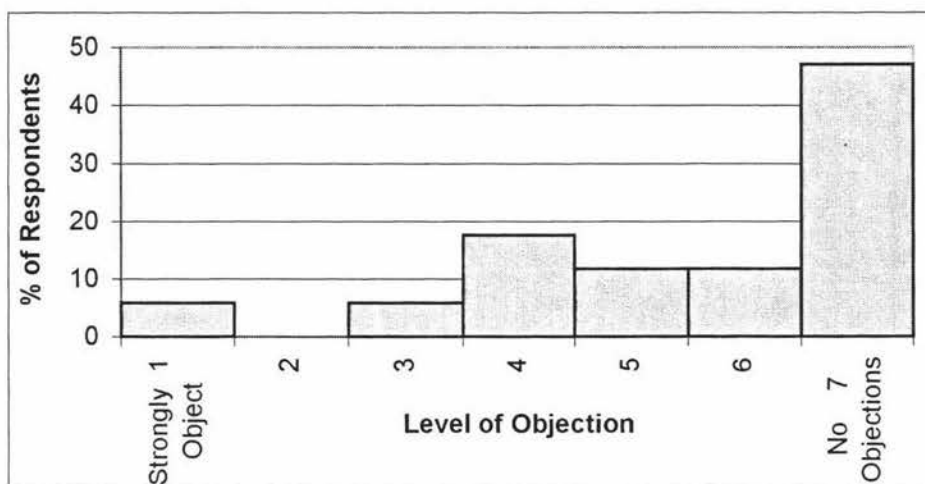
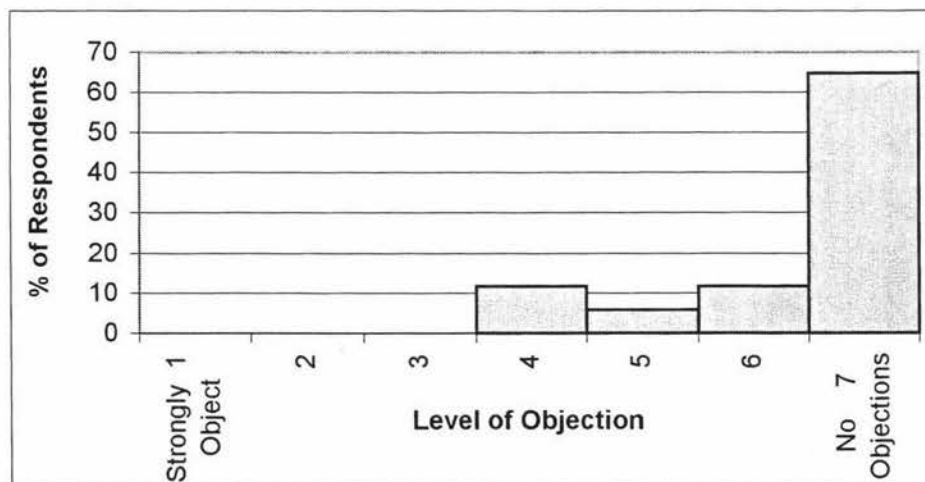
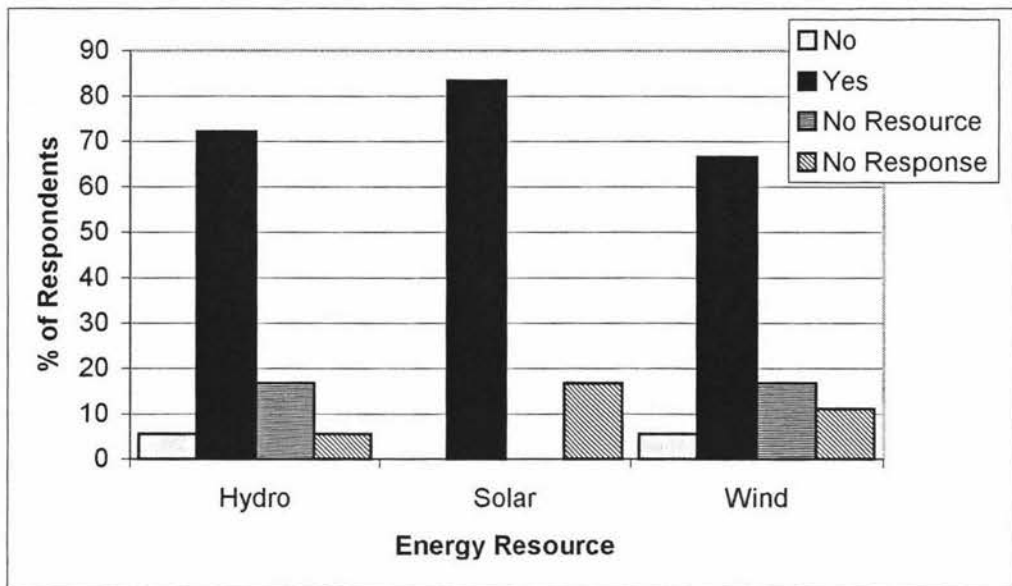

Figure 4.11: Level of objection to being supplied with electricity generated on other properties



Respondents were also asked to state whether they were “willing to have an electricity generation system installed on their property”, using the resources that were available to them (Figure 4.12). The results show that the majority of property owners are willing to generate electricity on their property if they have the potential to do so.

Figure 4.12: Willingness of respondents to generate electricity on their own properties



4.6.2.4 Buildings and Supply Connections

Respondents were asked how many buildings were supplied with grid electricity and how many connections supplied those buildings. The ratio of buildings per connection was calculated, with an average of 3.1. The maximum ratio was 10, where the land owner had his entire farm being supplied through a single connection. Renewable energy has already harnessed on some properties with 22% of respondents generating their own electricity from hydro turbines, solar cells and generators.

4.6.2.5 Heat Loads

Heating and cooling loads such as water heating and cooking are heavy consumers of electricity. Respondents were asked how these heat loads are currently met to determine the dependence on electricity (Figure 4.13). A wide variety of energy sources are currently used on the island, which could be related to the relatively recent connection to the national grid in 1975.

Figure 4.13: Energy sources used to meet heating and cooling loads

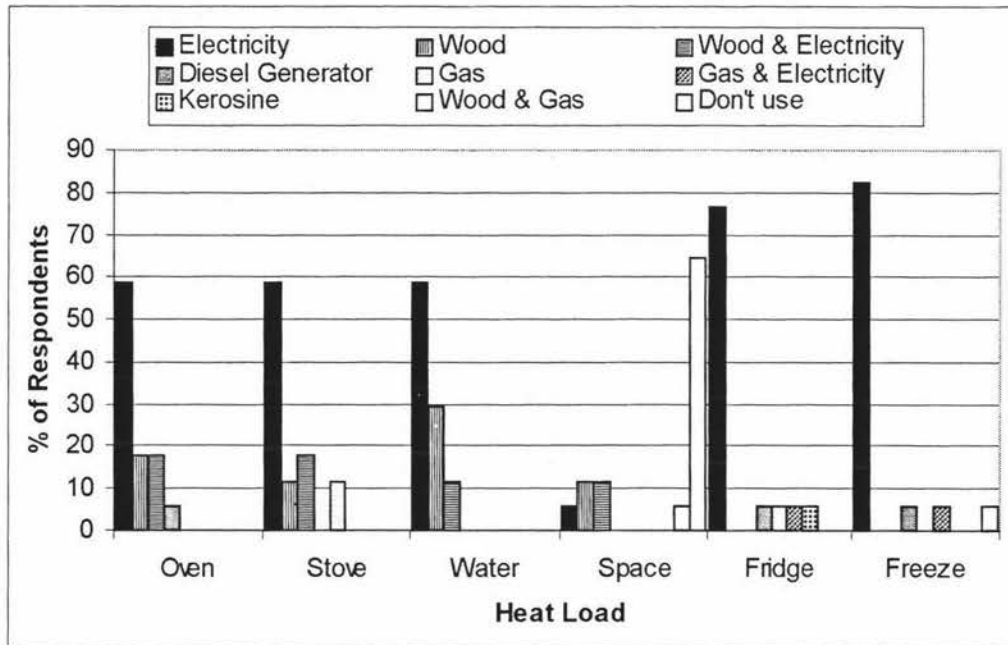

4.6.2.6 Satisfaction With Present Electricity Supply

Respondents were asked to rate their level of satisfaction with their supply with regards to power cuts, emergency service, rates and fluctuations in supply that caused problems with appliances (Figure 4.14). The results show that power cuts are the biggest supply issue for property owners. Damage to appliances as a result of variations in quality of supply were specifically identified by one property owner. (Note: only respondents connected to the national grid are included in these statistics).

Figure 4.14: Grid connected customers' satisfaction with their present power supply

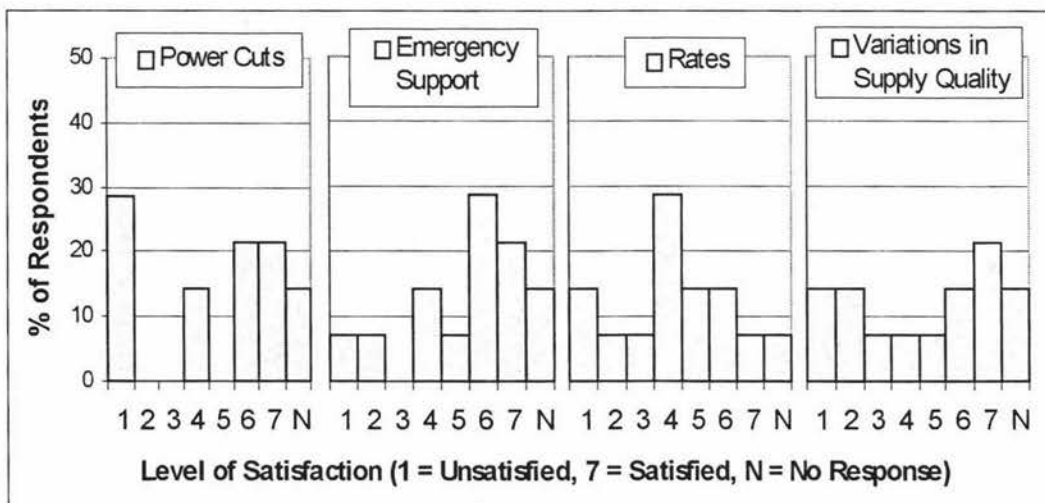

4.6.2.7 Community

The strength of the D'Urville Island community was assessed using questions regarding the communities ability to work together, the respondents' trust in other members, attendance at community events, and finally the respondents' interest in being involved a community scale scheme (Figure 4.15 to Figure 4.18). These results show that the level of trust and involvement within the community is less than for Totara Valley. However, the community does have some members who are strongly supportive of a community scale renewable energy scheme on the island.

Figure 4.15: View of how the community works together

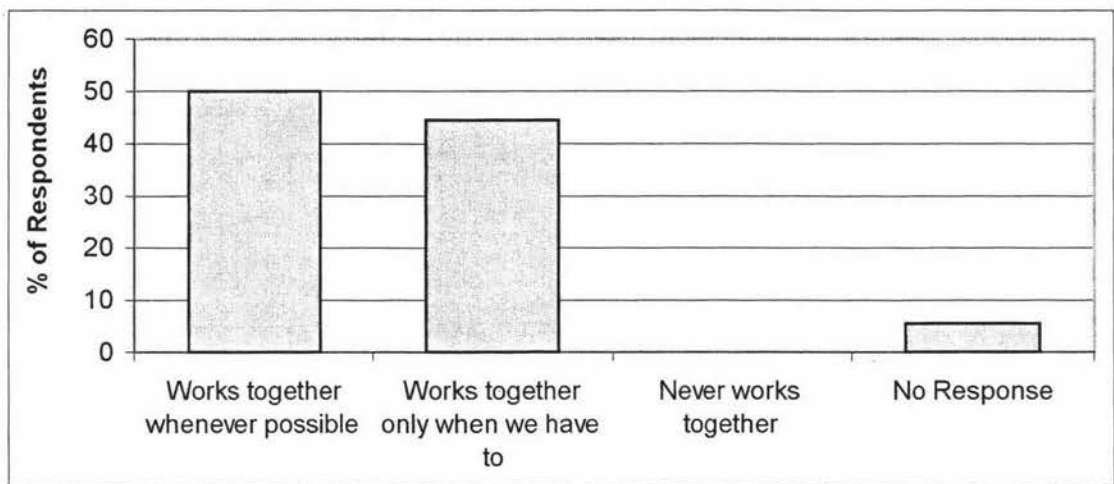

Figure 4.16: Trust of other community members

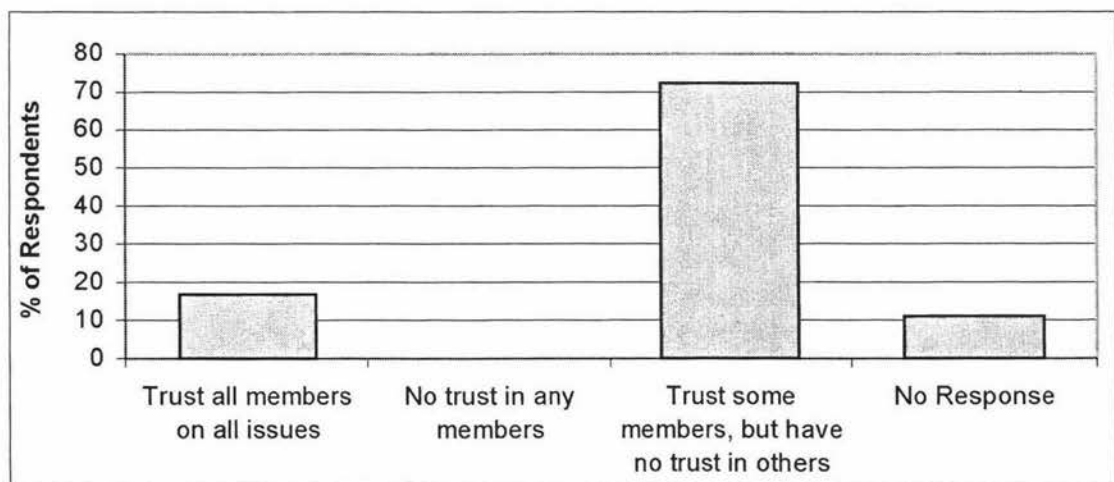

Figure 4.17: Involvement in the community through meetings and community newsletters

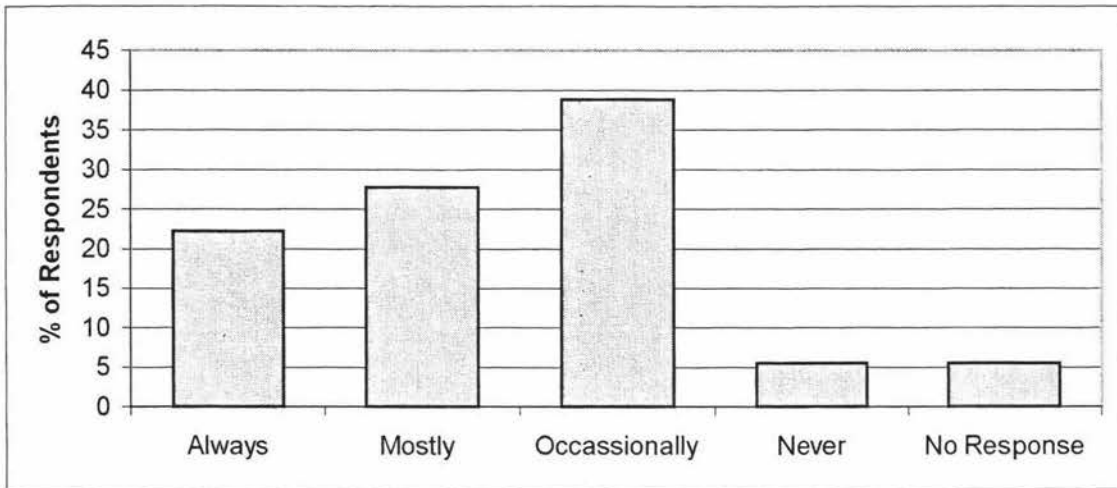
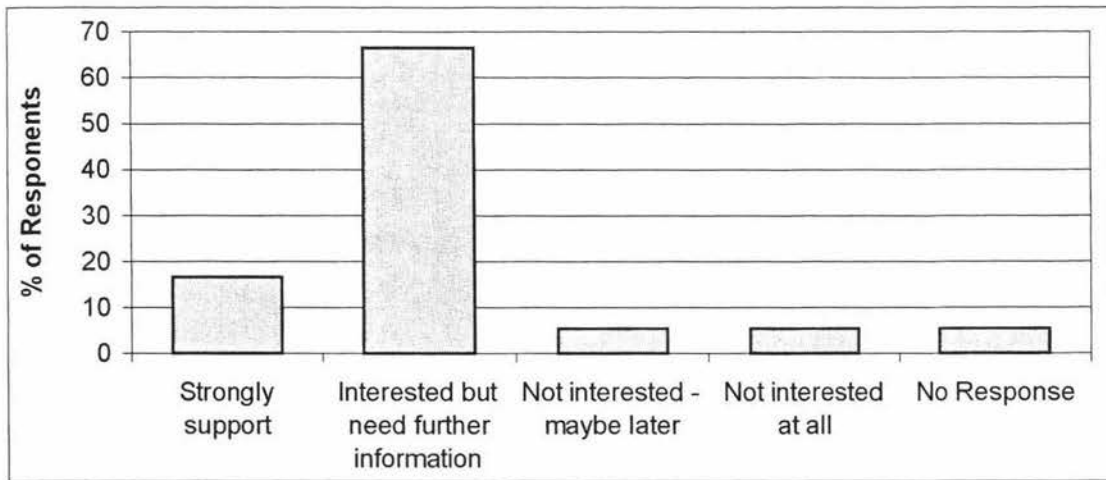

Figure 4.18: Level of support for a community owned and operated renewable energy scheme



4.6.2.8 Energy Efficiency

The final question asked the respondent to indicate their level of willingness (on a scale from 1 to 7) to take up energy efficiency practices within their home. Figure 4.19 shows the percentage of respondents that have already taken up such practices, and the percentage that indicated the highest level of willingness to take them up in the future. The use of hot water cylinder wraps, solar water heaters and greater awareness of appliance usage were the preferred energy saving options.

Figure 4.19: Uptake of energy efficient practices

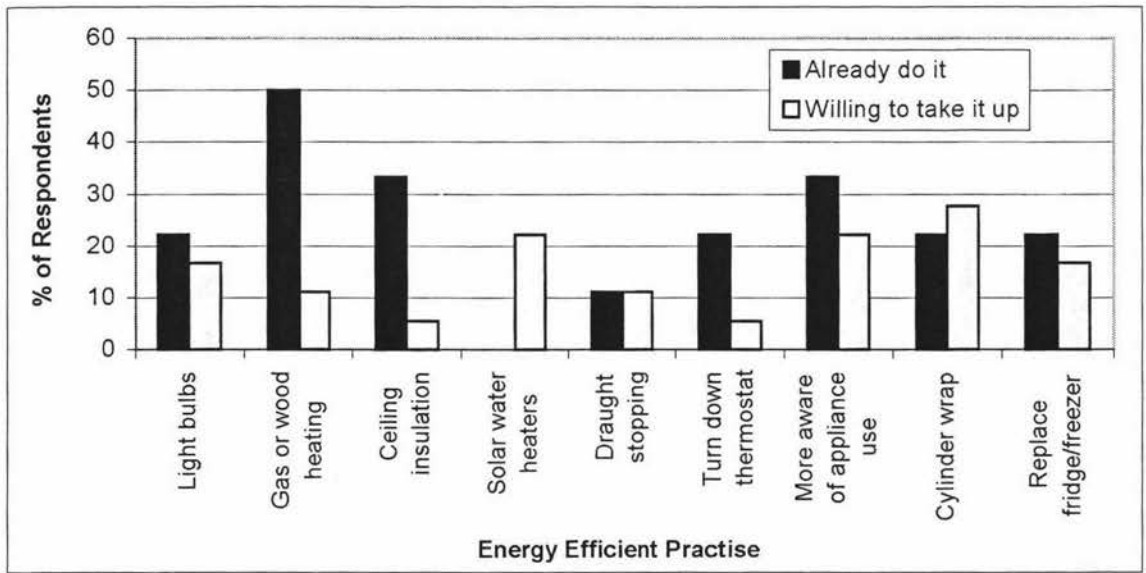

4.6.3 Akitio

4.6.3.1 Income Sources

Income to the community has a variety of sources (Figure 4.20). The major source is accommodation with other sources include fishing and farming. The village is also a popular retirement location.

Figure 4.20: Income sources of Akitio respondents

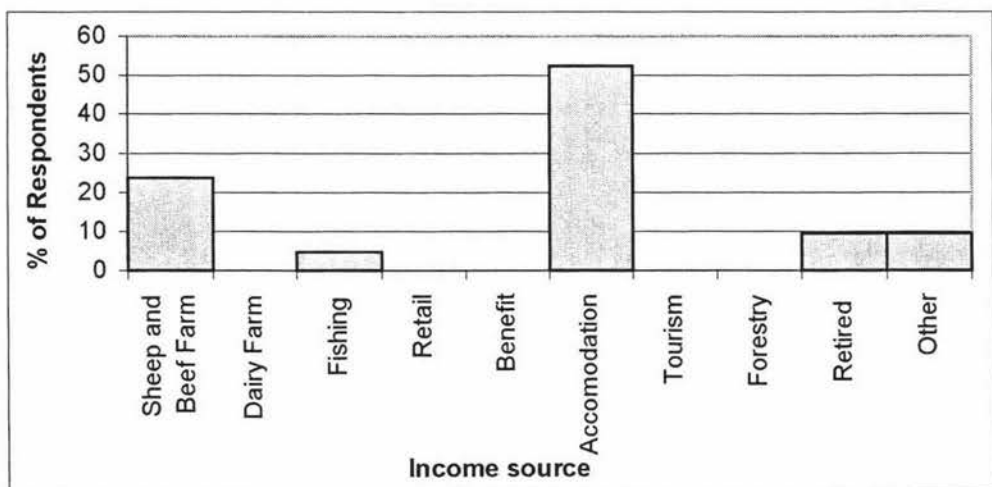

4.6.3.2 Energy Resources

Wind and hydro resources are only available to a small percentage of respondents. Continuously flowing streams were identified on two properties, although they were both considered to be too small for hydro development. Exposed ridges were identified on five properties. This means that most land owners involved in a community owned scheme would be dependent on electricity generated other members properties.

4.6.3.3 Involvement in a Community Scheme.

Respondents were asked to rate their level of objection to “having a generation scheme ... installed on their property that supplies electricity to other members of the community”. Of the six respondents that had energy resources on their properties five had no objections to others using those resources and 1 had some objections.

The results of the question relating to respondents’ level of objection to “using electricity that is generated on the properties of other community members” are shown in Figure 4.21.

Figure 4.21: Level of objection to supplying other community members with electricity generated on respondents’ properties

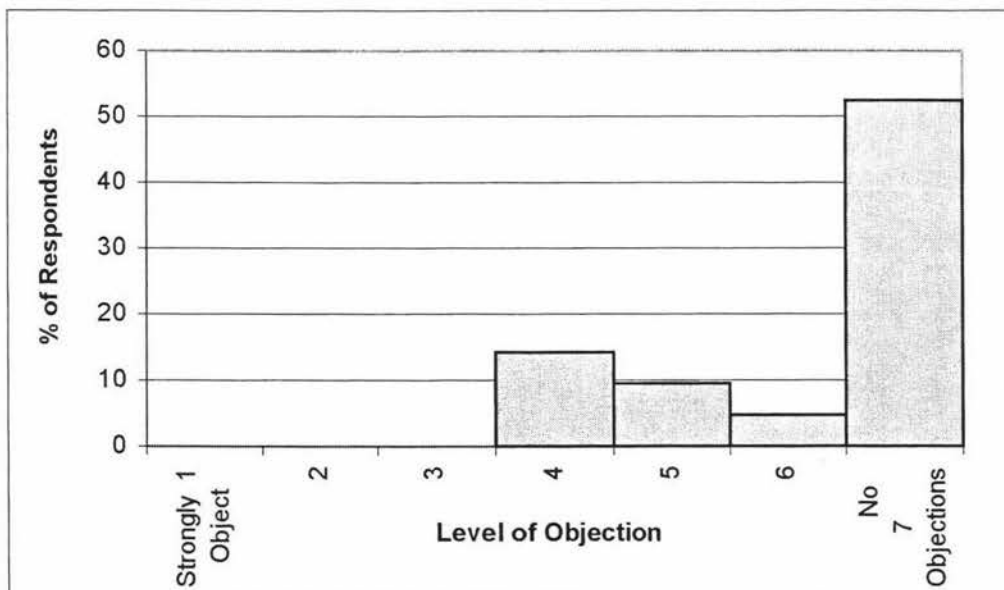

Respondents were also asked to state whether they were “willing to have an electricity generation system installed on their property”, using the resources that were available to them. Of the five that identified sites for wind generation on their properties, four were

willing for wind turbines to be installed. A community owned renewable energy scheme in Akitio would therefore need to be based around wind turbines on one or more of these four properties.

4.6.3.4 Buildings and Supply Connections

Respondents were asked how many buildings were supplied with grid electricity and how many connections supplied those buildings. The ratio of buildings per connection was calculated, with an average of 1.9. The maximum ratio was 10, where the land owner had 10 buildings being supplied through a single connection.

4.6.3.5 Heat Loads

Heating and cooling loads such as water heating and cooking are heavy consumers of electricity. Respondents were asked how these heat loads are currently met to determine the dependence on electricity (Figure 4.22).

Figure 4.22: Energy sources used to meet heating and cooling loads

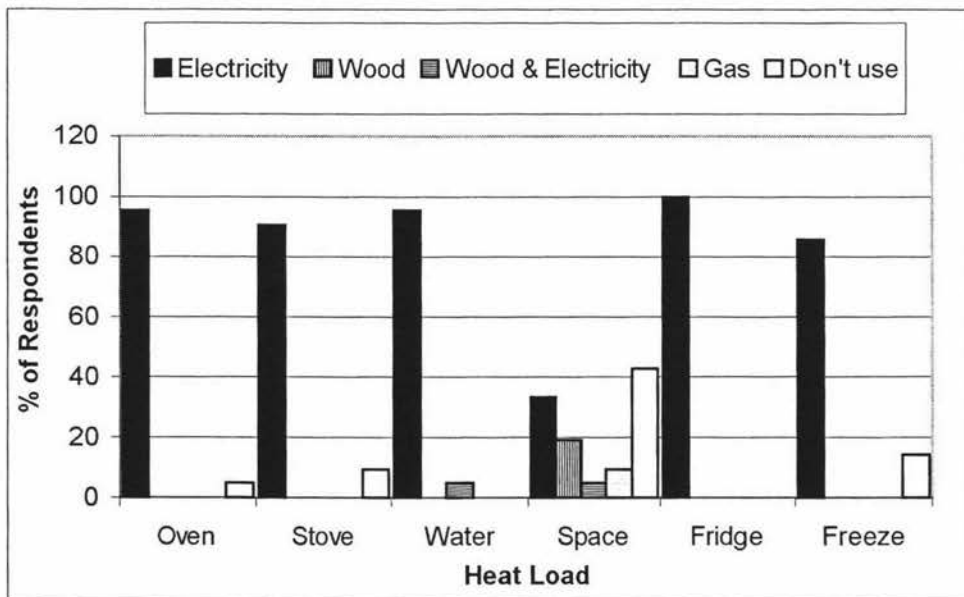

4.6.3.6 Satisfaction With Present Electricity Supply

Respondents were asked to rate their level of satisfaction with four aspects of their present power supply on a scale of 1 to 7. The aspects of their supply were power cuts, emergency service, rates and fluctuations in supply that caused problems with appliances (Figure 4.23). Respondents' expressed dissatisfaction with power cuts, rates

and variations in supply, but appeared satisfied with the emergency support they received.

Figure 4.23: Grid connected customers' satisfaction with their present power supply

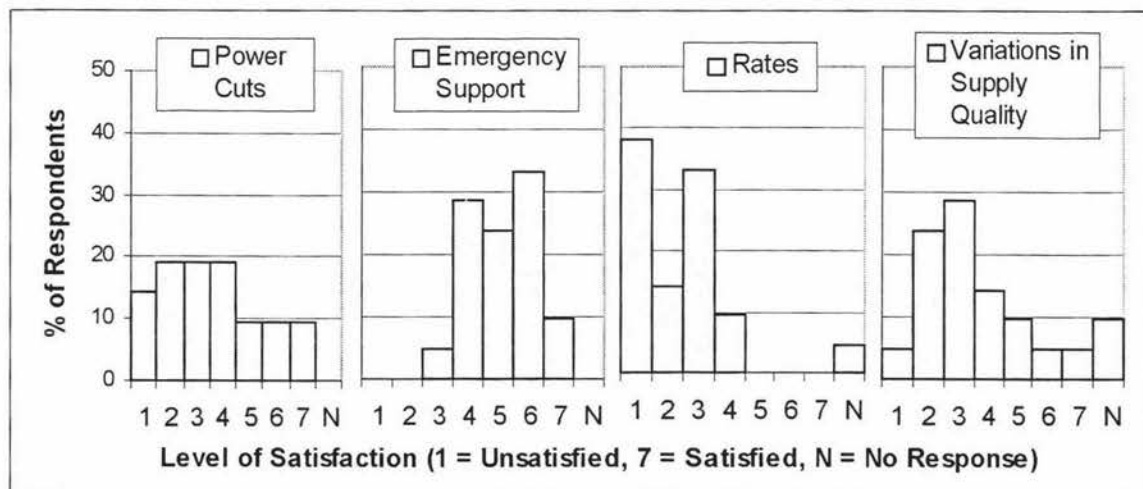

4.6.3.7 Community

The strength of the Akitio community was assessed using questions regarding the communities ability to work together, the respondents' trust in other members, attendance at community events, and finally the respondents' interest in being involved a community scale scheme (Figure 4.24 to Figure 4.27). The results of these questions show that property owners perceive the community to be one which works well together and is involved in community activities. There are also some community members that are strongly supportive of a community scheme.

Figure 4.24: View of how the community works together

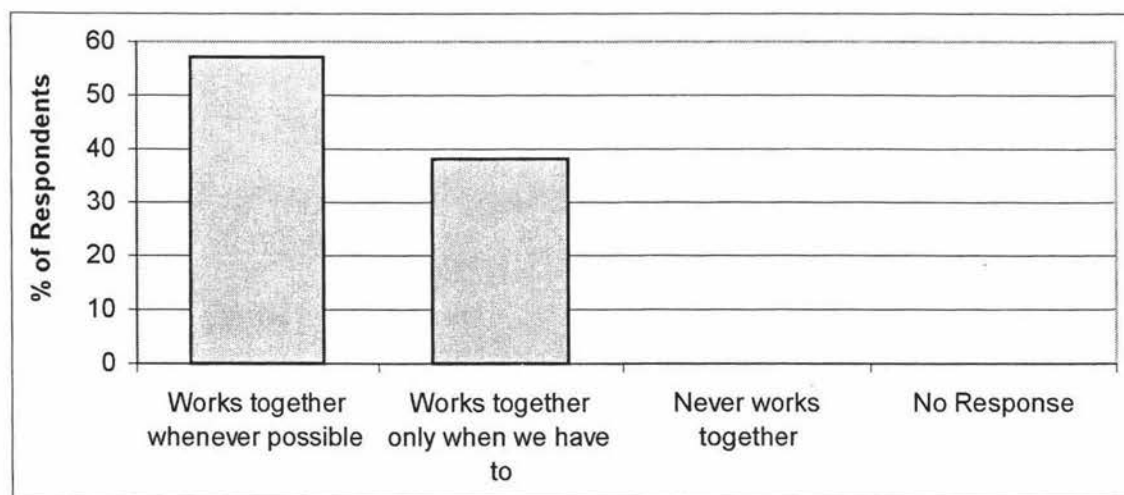

Figure 4.25: Trust of other community members

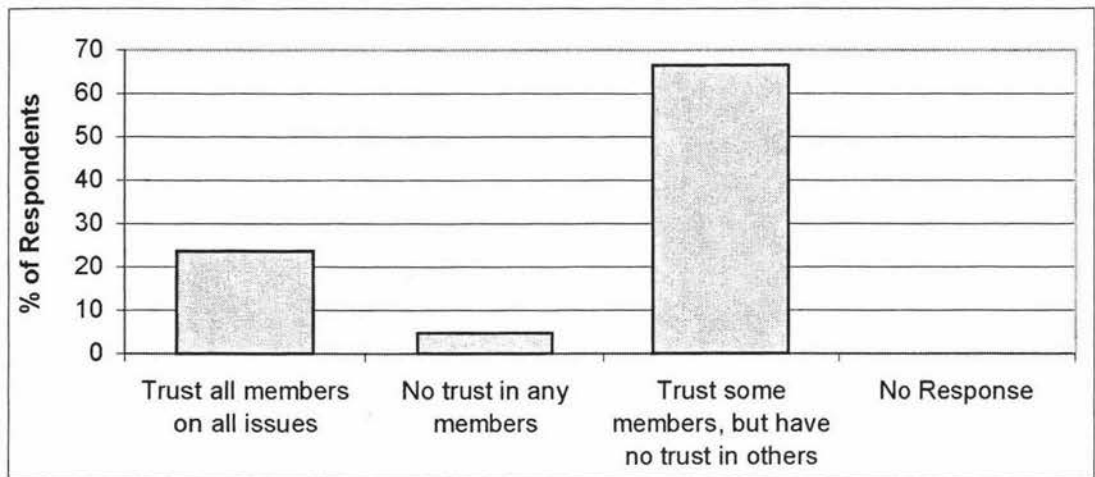

Figure 4.26: Involvement in the community through meetings and community newsletters

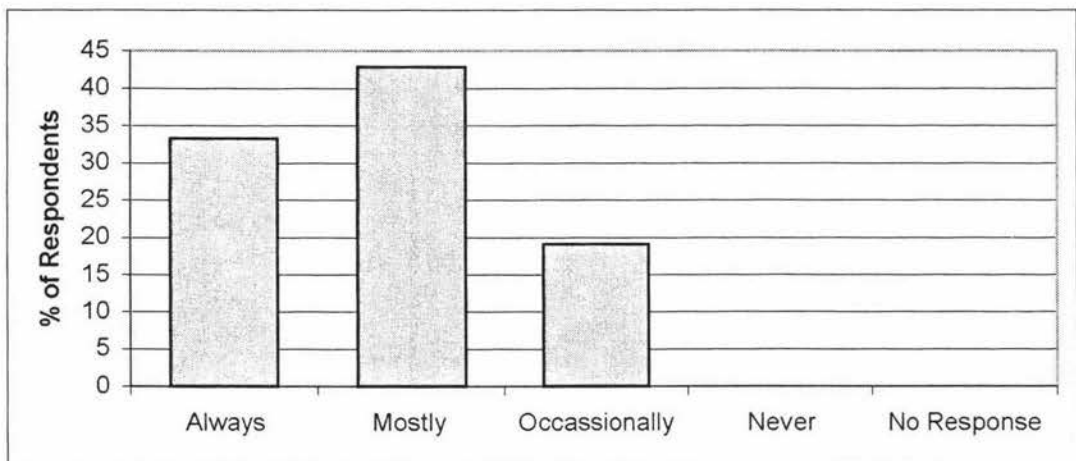
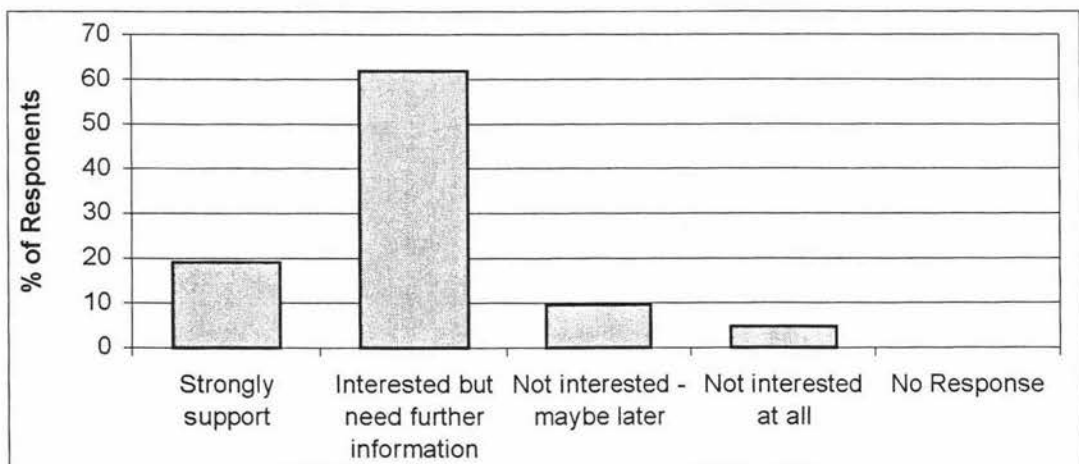

Figure 4.27: Level of support for a community owned renewable energy scheme



4.6.3.8 Energy Efficiency

The final question asked the respondent to indicate their level of willingness (on a scale from 1 to 7) to take up energy efficiency practices within their home. Figure 4.28 shows the percentage of respondents that have already taken up such practices, and the percentage that indicated the highest level of willingness to take them up in the future. Respondents were generally unwilling to take up energy efficiency practices, but identified ceiling insulation, draught stopping and hot water cylinder wraps as the preferred options.

Figure 4.28: Uptake of energy efficient practices

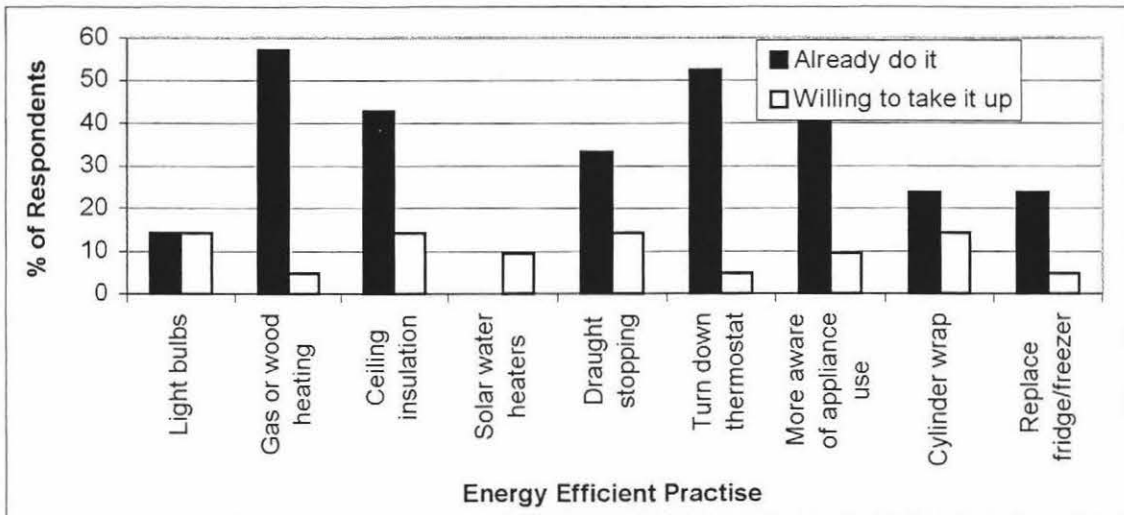

4.6.3.9 Akitio as a Case Study Site

As the response rate was very low for the Akitio site, a decision had to be made about whether it was worthwhile continuing with the community as a case study site. A community owned renewable energy scheme requires a strong community interest to be successful, and although those who did respond were interested, the response rate of the community demonstrated the opposite. Although initial interest in the study appeared to be high when the questionnaires were delivered, there was a strong feeling from some community members that the community would not be able to work together to maintain a community owned scheme. A number of other community based initiatives have been started in the past, but failed due to a lack of community participation and ownership (Wardle, 1998).

The Akitio site was therefore excluded from the study, and no further work was done within the community.

4.6.4 Summary

The household questionnaire enabled the available resources to be identified, and the willingness of community members to share these resources to be quantified. Most respondents were willing to share their resources with other community members. There was some reserve about participating in a community owned scheme, mostly due to a lack of knowledge about what such a scheme would involve.

The present supply of electricity through the national grid was not considered to be satisfactory by most community members. Lines and energy company charges were a concern for all three communities, and the quality of supply and power failures were identified as a problem at D'Urville Island and Akitio.

The dependence on electricity for heating and cooling applications was high, particularly in the Totara Valley. The use of gas or wood heating, ceiling insulation, and awareness of appliance use were the most common energy efficiency practices being used by the communities. Hot water cylinder wraps were the most likely energy efficient practice to be taken up community members.

5 Legal Ownership

There is no legal ownership structure that will be appropriate to all community owned renewable energy schemes in New Zealand. An outline of the basic differences between possible structures and the advantages / disadvantages of each is provided, along with the recommendations of a registered New Zealand law partnership.

5.1 Legal Structures Suitable For Community Energy Schemes

There are no community owned rural electricity schemes in New Zealand at present. Some electricity companies that were in existence before the Electricity Act 1998 came into force were owned by consumers in a trust, but these schemes were considerably bigger than those being considered in this study.

An example was Central Electric, a company which serviced the Central Otago region for about 70 years. A Trust owned the company, which worked for the good of the community. The company produced its electricity independent of the grid until 1957, and serviced 18,885 customers in 1997 (Sofield, 1997). Following the Electricity Act 1993 the company was divided up into the energy sector purchased by Trust Power, based in Tauranga, and the lines became Delta Electricity, based in Dunedin (The Christchurch Press, 1999). The power stations are still owned by the community, but it is likely that these will be sold in the near future.

As there are no community owned schemes operating in New Zealand at present it is necessary to look overseas to the experiences of the UK and Europe. Section 2.2.4.1 of the Literature Review gives a summary of the legal structures considered appropriate in the UK.

5.2 Options for New Zealand Communities

The industrial and provident society, and charities described by Mitchell (1995) are not relevant under New Zealand law, and are therefore inapplicable to the New Zealand situation. In order to identify the best options for the New Zealand situation, advice was

sought from Gawith Burridge, a law partnership based in Masterton. The study objectives were explained to one of the partners, and the document by Mitchell (which summarised the knowledge gained from community owned schemes in the UK) sent in order to ensure there was a clear understanding of what a community scheme would involve. Gawith Burridge concluded that three legal ownership structures would be suitable in the New Zealand legal environment:

1. Incorporated Society;
2. Limited Partnership;
3. Private Company.

5.3 Incorporated Societies

Incorporated societies provide a means by which people can legally be “associated together for a common purpose” (Paul 1986). In New Zealand an incorporated society is established under the Incorporated Societies Act 1908. Section 4(1) of this Act defines an incorporated society as:

“Any society consisting of not less than 15 persons associated for any lawful purpose but not for pecuniary gain.”

This definition immediately places three limits on any community seeking to establish this type of structure.

1. The society must consist of at least 15 persons. These 15 persons may include both spouses of a family, and any siblings over the age of 18, hence a community would need to consist of around eight families to operate under this structure. This limit would exclude the very small rural communities such as Totara Valley.
2. The purposes of the society must be deemed lawful by the Registrar of Incorporated Societies. Paul (1986) gave some examples of potentially unlawful activities: restraint of trade; likelihood of damaging the good order or conduct of the realm; formed for betting; gambling or breach of the criminal law. It is expected that community owned renewable energy schemes would be considered lawful, and would therefore be eligible for incorporation as a society.

3. An incorporated society is not permitted to enter into any transaction that would involve any monetary profit for its members. This means that the society itself can make a profit but the profit cannot be shared between the members until the society is dissolved. Section 5 of the Incorporated Societies Act specifies some circumstances by which members can receive money from the society.

Assuming that community owned renewable energy schemes are a lawful activity, a community decision to form an Incorporated Society is therefore dependent on the size of the community and whether or not the community is interested in making a profit for its members which can be shared among members at any time.

5.3.1 The Effects and Benefits of Incorporation

There are a number of benefits available to a community which decides to set up an Incorporated Society to administer their renewable energy scheme (Paul, 1986).

- The requirements of incorporation ensure the affairs of the society are conducted properly;
- Members cannot be held liable for the society's debts, and creditors cannot wind up a society except by application to the high court;
- An incorporated society is a separate body distinct from its members. It is not an agent or a trustee for its members;
- Perpetual succession – an incorporated society can continue despite changes in membership. It can only cease on winding up or dissolution by the Registrar;
- Common Seal – an incorporated society has a common seal that can be used in contracts and other legal documents;
- An incorporated society can bring or defend legal actions in its own name.

These benefits are standard to any incorporated society. If the rules of the society allow, it can also hold property, invest surplus funds, borrow money on the security of its assets, and obtain ordinary credit in its own name. One of the big advantages for a community owned renewable energy scheme is that the society can borrow money and own the generating equipment under its own name, giving protection to the individual members. It can be written into the rules of the society that any equipment owned by the society will be shared amongst the members if the society is dissolved.

5.3.2 Registration Requirements

In order to register as an incorporated society, six legal requirements need to be met.

1. Apply for approval of the proposed name – this approval is given by the Registrar of Incorporated Society at the Ministry of Commerce;
2. Submit two copies of the proposed rules;
3. Submit two copies of the application;
4. Submit a declaration to the effect “that a majority of the members of the society have consented to the application, and that the rules so signed and sealed are the rules of the society.” (Incorporated Societies Act 1908);
5. Submit a notice of the place of the registered office;
6. Payment of a fee - \$100.

5.4 Special Partnership

There are two broad categories of partnership available under New Zealand law. These are general partnerships and special (or limited) partnerships. The former is prescribed by Part I of the Partnership Act 1908, while the latter is prescribed by Part II of the same Act, which states:

“special partnerships may be formed for the transaction of agricultural, mining, mercantile, mechanical, manufacturing, or other business, by any number of persons.”

The only prescribed activities that cannot operate under a special partnership are banking and insurance. The special partnership is essentially a cross between a partnership and a limited liability company (Mulholland, 1983).

5.4.1 Characteristics of a Special Partnership

A special partnership may consist of general partners, and others known as “special partners”. General partners are jointly and severally liable for the debts of the partnership, while special partners are only liable up to the amount they agree to contribute to the partnership. General partners are considered to be analogous to ‘sleeping partners’, which means that they may not take any part in the running of the

business, (Mulholland, 1983, Webb and Webb, 1987). If they do, they are then deemed to be general partners.

While there appears to be no restriction on the number of partners involved in a special partnership, Webb and Webb (1987) suggested that it is best to keep the number of general partners to less than 25, as Section 456 of the Companies Act 1955 states that any partnership of greater than 25 persons shall be deemed a company, rather than a partnership.

Mulholland (1983) noted that any partnership which desires to approach the public for finance would be subject to the provisions of the Securities Act 1978. This means that the partnership would have to fulfill many of the requirements of a company and would also be required to issue a prospectus.

5.4.2 Establishing a Special Partnership

The process of establishing a special partnership is given in Section 51 of the Partnership Act 1908. The process requires that all persons entering into the partnership sign a certificate which must contain the following:

- the style of the firm under which the partnership is to be conducted;
- the names and places of residence of all the partners, distinguishing the general from the special partners;
- the amount of capital which each special partner contributes, and also the amount (if any) contributed by the general partners to the common stock;
- the general nature of the business to be transacted;
- the principal or other place at which it is to be transacted and the time when the partnership is to commence and when it is to terminate.

5.4.3 Maintaining a Special Partnership

Section 57 of the Partnership Act 1908 specifies that Special Partnerships cannot be entered into for more than seven years. This means that in order to maintain the partnership over the duration of a renewable energy scheme all partners would have to sign a new certificate (exactly the same as that required for the initial registration) every seven years.

5.5 Private Company

A private company is one in which the affairs of the company are restricted to the people who are involved in the company, whereas a public company relies on the general public to purchase and hold shares in the company. As a community owned renewable energy scheme would only be of interest to the members of the community, a private company structure would be the preferred option.

5.5.1 Definition of a Private Company

Dale (1968) defined a private company as one which:

- is registered under Part VIII of the Companies Act 1955 or the appropriate provisions of an earlier Act;
- has generally not less than two nor more than 25 members (but in special circumstances may have up to 50 members);
- states in its memorandum that it is a private company.

There is a limit with private companies as to how many people can hold shares in the company. This may become an issue for larger communities, but should not restrict the options of most smaller communities within New Zealand.

5.5.2 Advantages and Disadvantages of a Private Company

Chignell (1997) identifies four advantages in setting up a private company. These are:

1. The share holders have personal protection against creditors. This means that any debts owed by the company cannot be held against individual members of the company;
2. The company is a separate legal entity. In the case of a community owned renewable energy scheme this would mean that the company owned all the equipment, rather than the members of the community itself;
3. Perpetual Succession whereby the company can continue even when shareholders withdraw from the company. This is important for rural communities as members will come and go, but the company will continue. The only way the company can cease is to be removed from the New Zealand companies register by the Registrar;

4. Ease of transferability: It is very easy under the company structure to transfer shares amongst the community members.

There are also some disadvantages, especially for small communities. The first is the ongoing legal requirements and administration required. In a small community which does not employ any one person to do this task, this could become very burdensome. This will be especially noticeable when the community has been previously grid connected and is accustomed to simply paying accounts to an electricity company. Failure to meet the legal requirements can result in large fines for the community, so the task of administration needs to be carefully carried out.

The second disadvantage is the high tax rate. Chignell (1997) pointed out that in some cases this high tax rate could make a partnership or trading trust a better legal structure to work under.

5.5.3 Formation of a Company

There are six essential steps required to establish a company under New Zealand law (Chignell, 1997).

1. Reserve the name of the company. This involves checking that the name to be used is not already reserved, then reserving the name for the community;
2. File the appropriate Registration Documents. These documents can be obtained from the Companies Office, and need to be completed and returned within 20 working days from when the company name was reserved;
3. Receive a Certificate of Incorporation. This certificate is sent by the Companies Registrar, and provides conclusive evidence that the company is incorporated and has completed all the legal requirements of establishing a company;
4. Obtain an Inland Revenue Department (IRD) number. This can be done at any IRD office once the Incorporation Certificate is received. The company can also register for GST if the company has an annual income of more than \$30,000;
5. Open a bank account. The company should open a bank account from which all company business will be transacted. This will require a list of company signatories, and some funds to open the account. These funds will usually be payment for the initial shares of the company;

6. Make up a company folder. This will assist the community to keep the company in good running order and ensure that the company meets all its legal requirements.

5.5.4 Charges

There are a number of charges associated with setting up a private company. Table 5.1 below gives these charges.

Table 5.1: Charges for registering as a company in New Zealand

Charge Type	Cost
Name Reservation – manual	\$25.00
Name Reservation – electronic	\$15.00
Registration – manual	\$100.00
Registration – electronic	\$70.00
Annual Returns	\$30.00
Charges	\$50.00
Amalgamations	\$300.00

(Source: New Zealand Companies Office website)

5.6 Summary and Recommendations

There are three preferred options for legal ownership of a renewable energy scheme available to New Zealand's rural communities. The choice of structure a community decides to take up is dependent on whether or not the scheme is to make a profit for its members and the community size. Table 5.2 summarises the options, giving the required community size and the costs of registration for each option.

Table 5.2: Required community size and registration costs for the recommended legal structures

	Non Profit	Profitable	
	<i>Incorporated Society</i>	<i>Private Company</i>	<i>Special Partnership</i>
Number of Members	>15	< 50	<25
Registration Costs	\$100	\$85 - \$125	Free

The recommended legal structure for Totara Valley would be a special partnership. This structure would have the least cost to the community and minimise the required administrative work. However, care would need to be taken to ensure that all the

necessary legal protection for partnership members is agreed upon and made legally binding before the partnership is established (Carruthers, 2000).

The recommended structure for D'Urville Island would be an Incorporated Society. There are enough members in the community to use this structure and it gives the greatest legal protection to its members. It also requires less administration than a private company.

6 The Resource Management Act (1991)

Any renewable energy development in New Zealand must comply with the environmental standards set out in the Resource Management Act 1991 (RMA). The RMA is administered by city, district and regional councils through their council plans. This enables the RMA to be relevant and specific to each region of the country.

The objectives, policies and rules associated with wind and hydro developments in the two case study areas are reviewed and the implications of these rules to the case study communities discussed.

6.1 Resource Consents

6.1.1 Types of Resource Consent

Five types of resource consent can be applied for under the RMA. Table 6.1 gives examples of activities which would require the different consent types.

Table 6.1: Type of consent available under the RMA

Consent Type	Activities Requiring Consent
Land Use	Earthworks, clearing vegetation, building a bridge
Water	Using, diverting or damming a stream or river /floodwaters, taking water other than for stock and domestic purposes
Discharge	Discharge waste into water, air or on to land
Subdivision	Subdividing a section, inundating part of a section
Coastal	Building a wharf or jetty

(Source: Horizons.mw, 1999; ECCA, 1996)

6.1.2 Applying for a Resource Consent

The application process for a resource consent follows a standard format for all city, district and regional councils. The applicant must answer questions relating to their proposed activity to enable the local body to assess the potential environmental impacts. Written consent to carry out an activity must be obtained from all neighbours or other affected parties before an application is lodged.

6.1.2.1 Notification

The local body which assesses the application may decide whether the application should be ‘non-notified’ or ‘notified’. If the environmental effects of the proposed activity are minor and all affected parties have agreed to the activity, the application will be ‘non-notified’. This means that the decision to issue a consent is made without a public hearing. This type of application is considerably less expensive than a notified application.

If the environmental effects are not considered to be minor, or approval has not been obtained from all affected parties, the consent would be notified. In this case a public notice is placed in the newspaper, and/or at the site of the proposed activity. Copies of the application are sent to the relevant local bodies, affected parties, iwi authorities and special interest groups. Anyone may make a submission on the application within 20 working days of the consent becoming notified. If submissions are received, a meeting is held at the proposed activity site to discuss the application and attempt to resolve any concerns. If an agreement is not reached, the application may go to a formal hearing.

6.1.3 Information Required for Resource Consent Application

The local body responsible for issuing resource consents requires detailed information about the proposed activity in order to correctly assess the application. Horizons.mw, the regional council responsible for Totara Valley, lists the basic requirements for a consent application as being:

1. Location – a clear identification of the location of the land where the proposed activity is to take place. This includes the name of the district/city council territory in which the property is located and a site plan.
2. Description of the activity – in an application to use water for a hydro scheme, the description would include:
 - the watercourse name and names of other affected watercourses;
 - reason for the diversion;
 - whether the diversion is temporary or permanent;
 - quantity to be diverted;
 - dimensions of diversion pipe;

- location of any discharge point;
 - the catchment area above the dam or intake;
 - maximum dam crest height above downstream ground level;
 - dam crest length, width at base and top, storage capacity, surface area, spillway dimensions and construction material.
3. Assessment of environmental effects – a description of how the proposed activity will effect the environment and methods used to avoid, remedy or mitigate any adverse effects. This description will include:
- good and bad effects on plant and animal life, areas where food is gathered, significant wetlands, streams, rivers or lakes;
 - impacts on water quality or flooding potential;
 - measures used to control soil erosion and sediment movement;
 - whether the effects will be temporary, permanent or seasonal;
 - a list of other people or groups that may be affected by the proposal and any consultation that has taken place with these people;
 - identification of any surrounding areas of particular aesthetic or scientific value;
 - identification of any alternative water sources that could have been used and why they have been discounted;
 - how and by whom the environmental effects will be monitored (Horizons.mw, 1999).

6.2 Totara Valley

The applicable local body plans for the Totara Valley are the Tararua District Council Operative District Plan (1998) and the Horizons.mw (Manawatu Wanganui Regional Council) Land and Water Plan. This is at the hearing stage, but is still taken into account by Horizons.mw.

6.2.1 Designation

The Totara Valley is designated as a 'Rural' area by the Tararua District Council and Horizons.mw.

6.2.2 Tararua District Plan

6.2.2.1 Objective

The Tararua District Plan affects the development of a community owned renewable energy scheme through sections relating to Network Utilities. The plan states that the objective of the council in relation to network utilities is:

“To maintain and develop the District’s infrastructure to meet the community’s needs in a safe, effective and efficient manner while avoiding, remedying or mitigating adverse environmental effects.”

The explanation of this objective noted that the provision of services to the community is essential, and that it is in the community’s best interest to have these services delivered in an economically and practically viable manner. The District Council also accepts that utility operations will generally produce minor, temporary environmental effects, but also state that the effects of some major utility operations need to be controlled. This control is provided by designating these operations as discretionary, and therefore requiring a consent.

6.2.2.2 Environmental Standards

Section 5.3.6.5 of the plan details the required environmental standards and criteria for assessment related to network utilities. Two types of effects are considered, and the following factors are taken into account:

- Visual Effects:
 - scale of the facility;
 - height of the structures;
 - signage;
 - separation of structures to site boundaries;
 - site location – in terms of general locality, topography, geographical features, adjoining land uses and the consideration of alternative sites;
 - planting, fencing, use of colour and other landscape treatment;
 - lighting.
- Noise Effects:
 - background noise levels in the neighbourhood of the site;

- probable noise levels from the utility or any part of it;
- any proposed noise mitigation measures.

Wind turbines located in the Totara Valley would fail to meet the requirements relating to the size and scale of structures and would therefore require a resource consent. If the turbines were sited on ridges away from the dwellings the effects of noise would not become an issue.

Section 5.3.6.2 (c) states that “the construction, use and maintenance of simple structures for the investigation of sustainable energy generation by wind sun or hydro means” is a controlled activity, but does not require a consent. The plan does not mention the construction, use or maintenance of the equipment required to harness these resources, but it is obvious that the Tararua District Council has taken the development of these resources into consideration while preparing their plan.

6.2.3 Horizons.mw Land and Water Plan

Horizons.mw oversee the resource consent process relating to the physical environment. Their plans have implications for hydro developments in the Totara Valley, but do not address the issues relating to wind turbines (McNiell, 2000). The two sections of the Land and Water Plan that relate to hydro generation are:

- Chapter 3 – Discharges to Surface Water;
- Chapter 4 – Surface Water – Takes and Uses.

6.2.3.1 Discharges to Surface Water

6.2.3.1.1 Objectives

The objective of this part of the plan is “to maintain or enhance water quality in rivers to standards at least suitable for contact recreation at flows less than half-median.”

6.2.3.1.2 Policies

Policy 2 regarding discharges to surface water details the matters that would be considered for resource consent applications. These include:

- the effects of the discharge on: water quality; aquatic ecosystems; lake eutrophication; human health and amenity values;
- the nature of the discharge with regard to tangata whenua concerns;
- the presence of any non-biological or persistent contaminant in the discharge, and whether the contaminant is likely to accumulate in river or lake environments;
- whether any of the following effects are likely to arise in the receiving waters, after reasonable mixing, as a result of the discharge of the contaminant (either by itself or in combination with the same, similar, or other contaminants):
 - the production of conspicuous oil or grease films, scums or foams, or floatable or suspended materials;
 - any conspicuous change in the colour or visual clarity;
 - any emission of objectionable odour;
 - the rendering of fresh water unsuitable for consumption by farm animals;
 - any significant adverse effects on aquatic life;
- whether the discharge will cause any water in a river to be unsuitable for contact recreation at flows less than half-median;
- the outcome of consultation between the applicant and affected parties;

6.2.3.1.3 Rules

Policy 2 is achieved by the rules set out in the Discharge to Surface Water Rule 4. This rule states that any discharge of water or storm water to water is a Permitted Activity provided:

- the discharge is not from any industrial or trade premise;
- the discharge does not increase receiving water temperature by more than 3° C;
- the discharge does not cause erosion of the bed of the waterbody.

In relation to a hydroelectric development, the discharge of water back into the river would have to meet these criteria. A hydro development does not effect the quality or temperature of the water, but the outflow would have to be designed to ensure that erosion of the riverbed does not occur.

6.2.3.2 Surface Water – Takes and Uses

Chapter 4 of the Land and Water Plan addresses issues relating to the taking and use of surface water. These are: possible habitat loss caused by over-allocation of water from some rivers; increased flood risk due to damming and diverting artificial watercourses and habitat loss caused by draining and diverting wetlands.

6.2.3.2.1 Objectives

The objective of this section of the plan is:

“To maintain water levels in lakes and wetlands, and minimum flows in rivers, at levels that safeguard their life-supporting capacity.”

6.2.3.2.2 Policies

The one policy that relates directly to this study states that the following issues will be taken into account when considering a consent application:

- the effects of the activity on:
 - the natural flow regime;
 - the duration of low flows;
 - significant aquatic habitat for indigenous fauna and flora;
 - the available habitat for trout during low flows;
 - lake levels and lake margins;
 - water levels in wetlands;
- whether the river or lake is being managed for the purpose of fisheries or fish spawning by a classification in the Manawatu Catchment Water Quality Regional Plan;
- whether the proposed activity would adversely affect the specified values of any regionally significant river or lake identified in the Regional Policy Statement for Manawatu-Wanganui;
- whether the proposed activity would adversely affect recharge rates to groundwater aquifers;
- the effect of the activity on places or features of significance to tangata whenua;
- the demonstrated need for the volumes of water sought;
- the efficiency of the system for the proposed water use;
- the knowledge of the particular resource;

- whether the activity will increase the risk of flooding, or pose a risk to infrastructure.

6.2.3.2.3 Rules

There are four rules associated with surface water which apply to this study:

- SW Rule 4: ... any abstraction of surface water ... of 15 cubic metres or less per day is a Permitted Activity provided that where there is, or is intended to be, more than one abstraction point serving the land described in a particular certificate of title, the total existing and proposed abstractions serving the land described in that title do not exceed 15 cubic metres per day.
- SW Rule 5: ... the taking of any surface water ... of more than 15 cubic metres of surface water per day is a Discretionary Activity.
- SW Rule 6: The use of heat or energy from surface water is a Permitted Activity.
- SW Rule 9: ... any diversion of surface water is a Permitted Activity subject to:
 - a. the diversion does not cause lowering of water levels in any lake, river or wetland;
 - b. the diversion does not cause adverse effects on groundwater levels on neighbouring properties;
 - c. the diversion does not cause any erosion or flooding on neighbouring properties.

These rules would make the development of a hydro scheme a discretionary activity, as Rule 4 would limit a continuous diversion to a rate of only 174 millilitres per second. It is expected that for the Totara Valley site a resource consent would be required to divert the necessary volume of water, but that the consent would be non-notified (McNiell, 2000).

6.2.4 Consents Required

It is expected that a renewable energy scheme that includes wind and hydro generation at the Totara Valley site would require the following consents:

1. Land Use Consent from the Tararua District council for the erection of wind turbines;

2. Water Permit from Horizons.mw for diverting water for a hydro scheme;
3. Discharge Permit from Horizons.mw for discharging water back into a stream after it has been through a hydro scheme.

6.3 D'Urville Island

The applicable local body plan for D'Urville Island is the Proposed Marlborough Sounds Resource Management Plan (1995). The Plan consists of two volumes – Volume 1: Objectives, policies and methods, and Volume 2: Rules.

The introduction to the plan states that its purpose is “to promote the sustainable management of the natural and physical resources of the Marlborough Sounds.”

6.3.1 Designation

D'Urville Island is designated as mostly Rural 1 Zone, with some areas of Conservation Zone in the middle of the island.

6.3.2 Policies and Objectives

6.3.2.1 Section 2 - Natural Character

Natural Character is defined as “those features and qualities that have been brought into being by nature.” The objective of this section is stated as “the preservation of the natural character of the coastal environment, wetlands, lakes, and rivers and their margins” and the policies that relate to this study are:

- Section 2.2 - Policy 1.3: To consider the effect on those qualities, elements and features which contribute to natural character, including: coastal and freshwater land forms; indigenous vegetation and the habitats of indigenous fauna; water and water quality; scenic or landscape values; cultural heritage values, including historic places and sites of significance to iwi.
- Section 2.2 - Policy 1.6: In assessing the appropriateness of subdivision, use or development in coastal and freshwater environments regard shall be had to the ability to restore or rehabilitate natural character in the area subject to the proposal.

These policies and objectives make it clear that the preservation of natural character is important to the Marlborough District Council. Any renewable energy project will need to ensure that the environment is returned to its natural state as fully as possible. The remainder of the plan builds on these initial objectives and policies.

6.3.2.2 Section 3 – Water

There are two major issues associated with water that are addressed in the plan. These are the degradation of water quality and quantity. Water quality is not a concern for micro hydro developments, but there are two policies that do need to be taken into consideration:

- Section 3.2.2 - Policy 1.5: Minimise the amount of sediment leaving the land from activities such as excavation, soil disturbance and vegetation removal.
- Section 3.2.2 - Policy 1.6: Promote and encourage land use practices and measures which avoid, remedy or mitigate adverse affects on water quality.

These policies relate to the construction of hydro schemes, as this is the period when soil extraction would occur.

The effects on water quantity are a more important consideration for micro hydro schemes as they involve removing water continuously from the streambed. The main objective is “that the natural functioning of ecosystems is not disrupted by the taking, use, damming and diversion of fresh surface water”. (Section 3.2.5 – Objective 1). There are four policies associated with this objective:

- Section 3.2.5 - Policy 1.1: Adopt a precautionary approach towards the allocation of surface water resources;
- Section 3.2.5 - Policy 1.2: Give priority to the maintenance of instream flows over abstraction from permanently flowing rivers;
- Section 3.2.5 - Policy 1.3: To avoid adverse environmental effects on instream values from the taking of fresh surface water. Generally this will mean not more than 30% of the five year seven day low flow is allocated for abstraction.

This last policy in particular places restrictions on the island's hydro generating potential. As most of the streams on the island have a low flow rate but high head, this limit would reduce the allowable flowrate in most streams to 1 – 2 l/s.

6.3.2.3 Section 5 – Landscape

This section of the plan is particularly relevant to any wind developments which may be developed on the island, as wind turbines are usually placed on exposed hilltops to maximise their electricity production. This section identifies rolling ridgelines, and specifically D'Urville Island, as areas of outstanding character. Section 5.2 notes that “network utilities and associated buildings (towers, masts, transmission dishes, and lines) where located on hilltops can have a significantly detrimental effect on the visual values of important skylines”.

The main policy associated with protection of landscape values is:

- Section 5.3 - Policy 1.1: Ensure that structures built on land do not compromise outstanding landscape values.

This issue is not a new one for the D'Urville Island area as similar issues were raised with the installation of the overhead electricity cables crossing French Pass. Turbines would need to be sited carefully to reduce the area from which they would be visible.

6.3.2.4 Section 11 - Rural Environment

The objective of this section is the “sustainable management of rural resources and integrated resource use to protect the character and amenity of rural areas and avoid, remedy or mitigate adverse effects of rural activities on the rural environment”. The only policy relating to this study is:

- Section 11.3 - Policy 1.2: Maintain the character and amenity values of the rural environment by ... avoiding unnecessary visual intrusions into the rural landscape by limiting the height and controlling the siting of buildings and ancillary structures including and avoiding erection of structures and other developments on headlands, skylines...”

This policy makes it clear that structures in visible areas are to be avoided as they are deemed to detract from the natural environment.

6.3.2.5 Section 20 – Utilities

The Marlborough District Council state that “utilities form an essential part of the community infrastructure”, and that “communities are unsustainable without the provision of water supply, drainage, sewage disposal, energy and communications”. The Plan defines utilities in relation to this study as energy, electricity lines, cables, pylons, receivers, transmitters and substations.

With regard to utilities, Section 20.2 states that “some utility network structures, such as transmitters and masts, need to be sited in prominent positions in the landscape in order to fulfill their functions. The essential nature of utility services, the specificity of site suitability and the adverse effects of their prominence all need to be taken into consideration.”

The first objective of this section of the plan is: “The continued operation, maintenance and development of essential utility networks necessary to sustain people and communities in the Sounds.” The policies that support this objective are:

- Section 20.3 – Policy 1.2: Enable individuals to contribute to or provide their own utility needs in appropriate areas.
- Section 20.3 – Policy 1.5: Enable buildings, structures and equipment necessary or ancillary to utility networks to be established throughout the Marlborough Sounds area.
- Section 20.3 – Policy 1.7: Provide a fair and reasonable means of financing extension of community utility networks without placing an unfair burden on the general community.

The second objective is: “The establishment and operation of utility networks in a way that avoids, remedies and mitigates the adverse effects of those networks on the environment.” Related to this are the following policies:

- Section 20.3 – Policy 2.1: Require construction and maintenance practices that avoid, remedy and mitigate land disturbance associated with utility management.
- Section 20.3 – Policy 2.2: Ensure that utility network construction, maintenance and operation avoids adverse effects on water quality.

- Section 20.3 – Policy 2.3: Enable the provision of individual water supplies and electricity generation where appropriate to supplement services to rural households.
- Section 20.3 – Policy 2.4: Maintain visual amenity by avoiding or mitigating the potential adverse visual effects of utility network structures.

At the conclusion of this section the plan states that the anticipated environmental benefits are “sustainable utility networks which operate without adverse environmental effects” and “small settlements with sustainably managed community based utility services”. Both these results can be achieved with a community owned renewable energy scheme.

6.3.3 Rules

The Plan rules determine how the above objectives and policies will be met. Any project which takes place needs to conform to all relevant rules in the Plan, or else obtain resource consents where the rules cannot be adhered to.

6.3.3.1 *Micro Hydro Schemes*

Any micro hydro scheme would fail to meet the standards of Rule 1.1.3, which states:

“The taking of water from any naturally occurring waterbody other than for an individual’s reasonable domestic needs, or the reasonable needs of an individual’s animals for drinking water shall be a Discretionary Activity with no limits on the Councils discretion.”

The definition of “domestic needs” requires clarification to determine whether or not the production of electricity is considered to be a domestic activity.

The second rule relating to hydro schemes is Rule 1.2.1 which states that “the damming of any stream is a Permitted Activity” subject to the following conditions:

1. That the damming of any streams shall not deprive any person of water reasonably required for the person’s domestic water supply or stock drinking water requirements or fire fighting needs.
2. That the damming shall not significantly adversely affect the suitability of water needed for any other authorised use.

3. That the damming shall not have any adverse effect on any fishery, wildlife or conservation values, and all practicable measures shall be taken to minimise any adverse effect to fisheries, wildlife or recreational values
4. That the damming of any stream is limited to the damming of streams draining a catchment area of no more than 20 hectares in area immediately upstream of the dam.
5. That the damming shall not be carried out without the consent of those persons who may be adversely affected by the damming of the stream.

The rule which has the most significant relationship to hydro developments is Rule 4, which limits the available catchment above the hydro intake. However, if an intake structure that did not require damming of the river was used this rule would no longer apply.

6.3.3.2 *Wind Turbines*

Wind turbines are not mentioned specifically in the Marlborough District Plan, so there are no rules associated with their use. However, the policies and objectives discussed in Section 6.3.2 suggest that the erection of a wind turbine would contravene the objectives of the council and the RMA. It is therefore expected that wind turbines would require a resource consent.

6.3.4 Consents Required

It is expected that a renewable energy scheme that includes wind and hydro generation on D'Urville Island would require the following consents from the Marlborough District Council:

1. A water permit for the diversion of water for each hydro scheme;
2. A land use consent for the erection of wind turbines.

7 Energy Resource and Electricity Demand

This chapter quantifies the energy resources that are available to the two case study communities, and defines the electricity consumption profile that needs to be met for each community. Methods of data collection are given and the results summarised in the form in which they are used in the computer model.

7.1 Totara Valley

7.1.1 Energy Resources

Totara Valley has hydro, wind and solar energy available (Figure 7.1). Monitoring of these resources was carried out over a one year period.

Figure 7.1: Location of energy resources and buildings

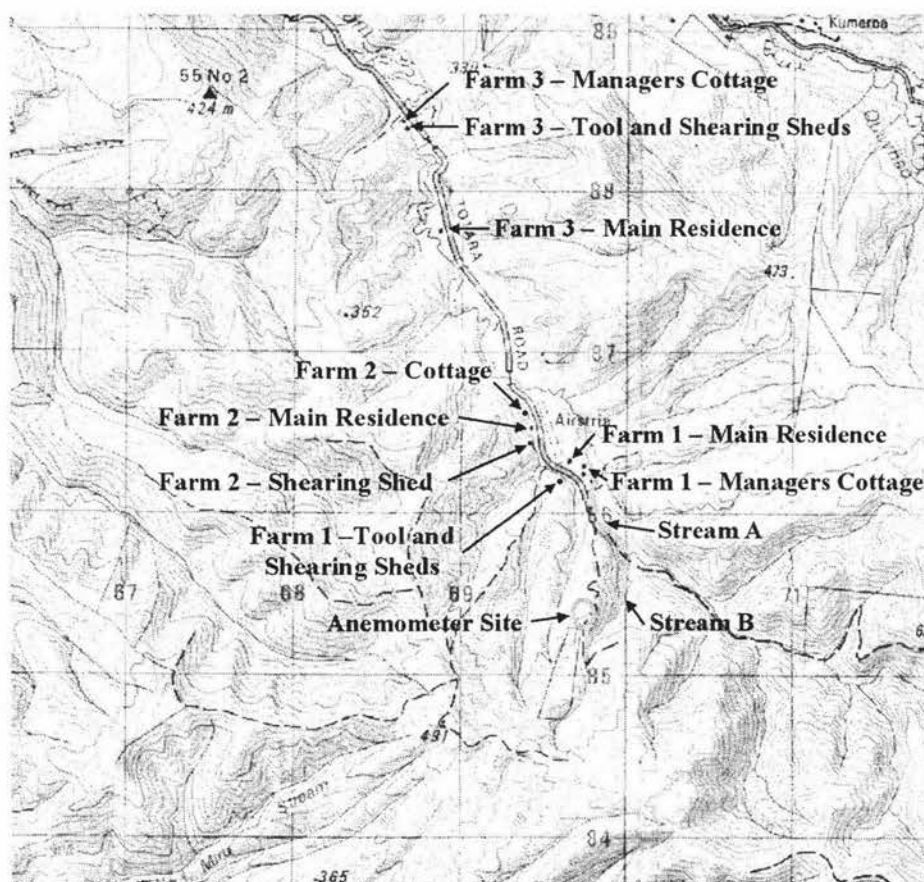

7.1.1.1 Hydro

Two streams within the Totara Valley catchment were identified as being suitable for run of the river micro hydro electric development. The Totara Stream flows down the length of the Totara Valley (Figure 7.2). Monitoring of water flow rates in this stream was carried out between 31/12/1998 and 12/08/99. Measurements were made by the land owners at the head of the valley on a monthly basis.

The section that could be developed for hydro energy is free of overhanging bush, with grass paddocks along both banks. The section upstream of the proposed intake is covered in dense bush.

The flow rate was measured at a concrete culvert downstream of the intake site, using the float method described in Section 2.4.5.1.1. The culvert provided an easily definable cross section in the stream bed, which did not change with flood events, and there are no side streams entering Totara Stream between the proposed intake site and the culvert (Figure 7.2 and Figure 7.3). For each section the time was recorded for a float to pass the length of the culvert, then multiplied by the section area and length and a correction factor of 0.65 to give the flowrate. The flow rates of the three sections were then combined to give the total flow.

Figure 7.2: The culvert used to measure flow in the Totara Stream

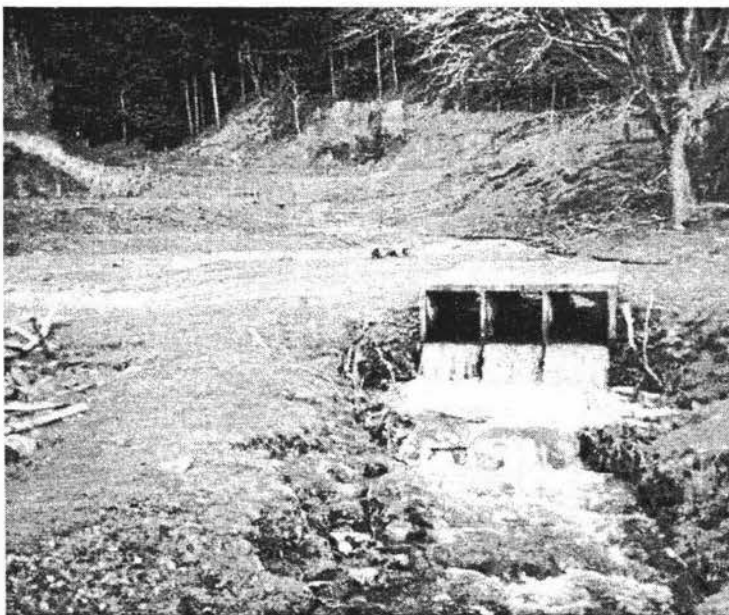
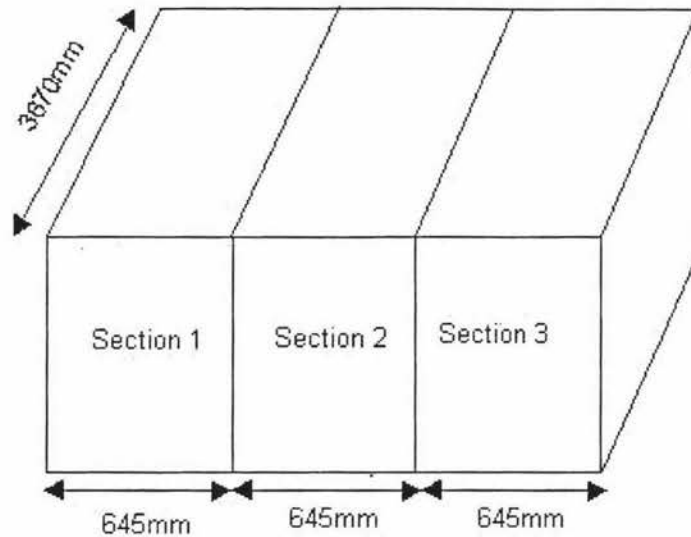

Figure 7.3: Culvert dimensions



The results of the flow monitoring are given in Table 7.1. The stream gave an average flowrate of 57 l/s, with a minimum flowrate of 28 l/s on 02/04/1999. This minimum flowrate was used in the Renewable Communities computer model. The maximum recorded flowrate was 144 l/s on 12/08/1999.

Table 7.1: Flow measurements at the Totara Stream culvert

Date	Section 1 Depth (mm)	Section 2 Depth (mm)	Section 3 Depth (mm)	Time (sec)	Flow rate (l/s)			Total
					Section 1	Section 2	Section 3	
31/12/98	40	50	60	4	24	30	36	58
15/01/99	30	40	45	5	14	19	21	35
26/01/99	30	30	40	5	14	14	19	31
2/04/99	20	22	30	4	12	13	18	28
28/04/99	22	32	50	4	13	19	30	40
30/05/99	30	45	60	4	18	27	36	52
30/07/99	40	55	75	4	24	33	44	65
12/08/99	75	95	110	3	59	75	87	144

The available head of 13.5m from the proposed intake site to the farm buildings was measured using a sighting level and verified with a digital altimeter. The horizontal distance between the intake and the turbine site is 540m.

The second stream available to the community flows into the true left of Totara Stream, 550m from the farm houses (Figure 7.4). This stream is free of thick vegetation along its length, and flows over solid rock outcrops at its head.

Figure 7.4: The second stream identified within the Totara Valley catchment



The available head of this stream was measured to be 162m with a digital altimeter. The flowrate was measured on 16/02/1999 by recording the time taken to fill an 18 litre bucket. This procedure was repeated five times, giving a flowrate of 2.4 l/s. The distance between the proposed intake site and the turbine site is 718m.

7.1.1.2 Wind

The wind resource at Totara Valley was monitored from 26/02/1999 to 26/02/2000 on a ridge above the farm at the head of the valley, a distance of 700m from the nearest house (refer Figure 7.1). This site was identified by the land owner as being particularly windy, and it was exposed in all directions. The nearest obstruction to the wind was a stand of mature pines 300m further down the ridge. There were no significant obstructions in any other direction. Transport access to the site was also very good.

Monitoring was carried out using a data logging system consisting of:

- Max 40 anemometer to monitor wind speed
- Wind vane to monitor wind direction
- Campbell CR500 datalogger to store data
- 10m mast, with six guy cables

The Campbell CR500 datalogger was set up to record the average wind speed and direction every hour from readings taken every 10 seconds. It also recorded the maximum wind gust over each hour period.

Figure 7.5: The wind monitoring equipment

(a) the wind vane and anemometer

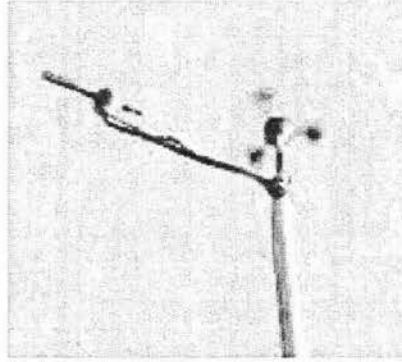

(b) the datalogger and battery



7.1.1.2.1 Wind Speed

The variation of windspeed over the twelve month monitoring period is shown below (Figure 7.6). The annual average windspeed at the site was 5.4ms^{-1} . The windiest month was November with an average speed of 6.4ms^{-1} . The maximum gust recorded during the year was 68ms^{-1} recorded at 3am on 17/04/1999, and the gust factor¹ was 6.5.

¹ Gust Factor = Maximum Recorded Gust / Average Hourly Gust

Figure 7.6: Average monthly wind speeds for Totara Valley in 1999

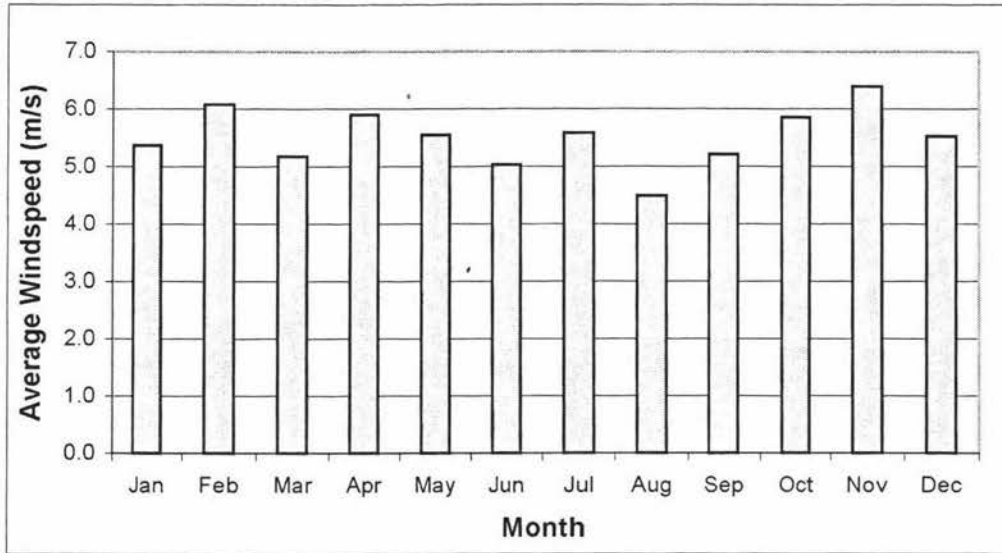

7.1.1.2.2 Wind Speed Distribution

The wind speed distribution is used to determine the output of a wind turbine in a given wind regime. The computer model developed by the author describes this distribution using the Weibull function, which is dependent on shape (k) and scale (c) parameters. These parameters were determined using two methods. The first is described by Frost and Aspliden (1994) and uses the following methodology:

1. an observed wind speed distribution is established with wind speed occurrences grouped in wind speed bands (e.g. $0 - 1 \text{ ms}^{-1}$, $1 - 2 \text{ ms}^{-1}$ etc.);
2. a duration curve (probability of actual wind speed being greater than a certain wind speed value) is determined from the histogram;
3. the cumulative probability curve is plotted in the linear form $y = mx + y_0$,
where $x = \ln(\text{wind speed band value})$
 $y = \ln[-\ln(\text{probability of wind speed} > \text{band value})]$
4. A least squares curve fit is then made with the data with a slope (m) and y intercept (y_0);
5. The Weibull shape parameter is the line of slope (m), and the Weibull scale parameter is given by $c = \exp(-y_0/m)$.

The second method used an Excel Solver function to optimise the two parameters so that the difference between the optimised Weibull function and the observed windspeed distribution is minimised². Figure 7.7 shows the recorded windspeed distribution, along with the calculated and optimised Weibull curves.

Figure 7.7: Windspeed distribution and calculated and optimised Weibull curves for the period 26/02/1999 to 26/02/2000

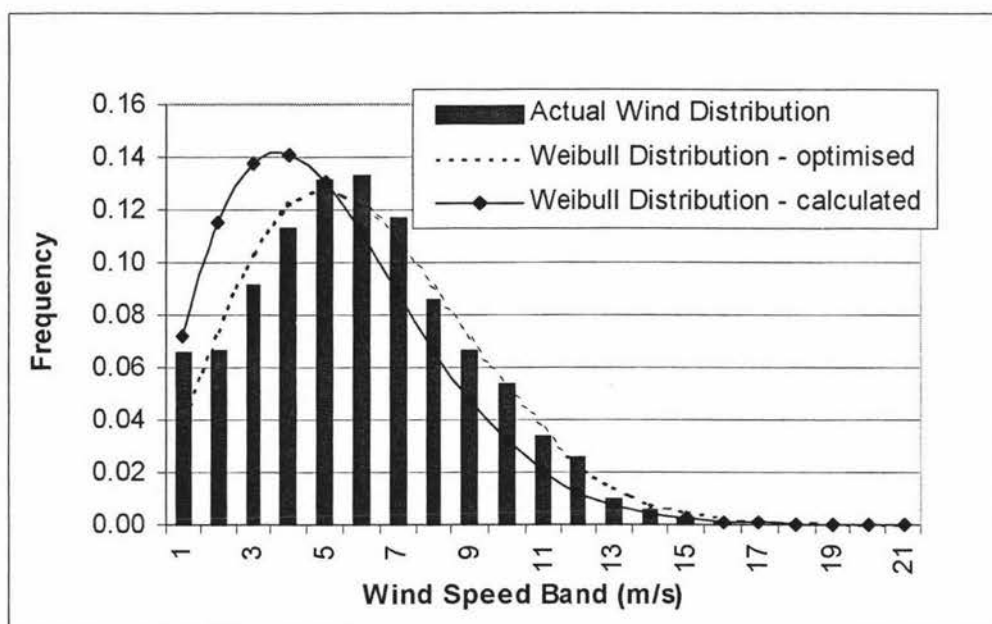

An analysis of the strength of relationship between the actual data and the calculated data gave an R^2 value of 0.857. The R^2 value for the relationship between actual and optimised data was 0.971. The optimised Weibull function parameters therefore give a better fit to the recorded data, so these have been used in the computer model. The optimised shape parameter is 2.07, while the scale parameter is 6.89.

7.1.1.2.3 Wind Direction

The average wind direction for each hourly period was recorded during the monitoring period. The percentage of time the wind blew from each direction, based on these hourly readings, is shown below (Figure 7.8). The predominant wind direction was from the south west, with a small percentage of wind coming from the north east.

² The Weibull function is given in Appendix A, section A.2.2.

Figure 7.8: Percentage of the monitoring period that the wind blew from each direction

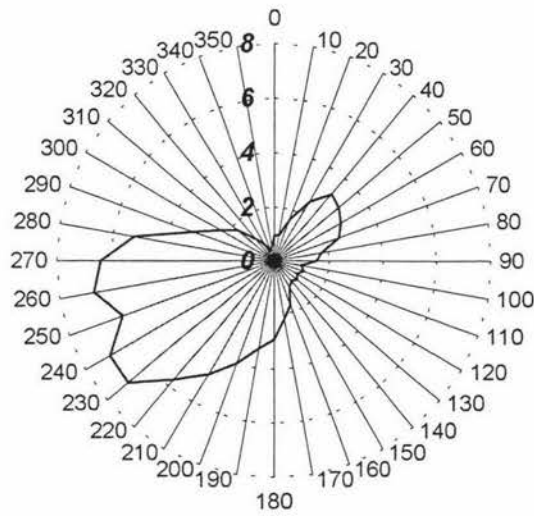

7.1.1.3 Solar

Global solar radiation was monitored from 26/02/1999 to 26/02/2000 using a solarimeter (Figure 7.9) and the same Campbell CR500 datalogger used to monitor the wind. A number of difficulties were experienced with the solarimeter during this period, which resulted in an incomplete data set.

Figure 7.9: The solarimeter used to monitor global solar radiation

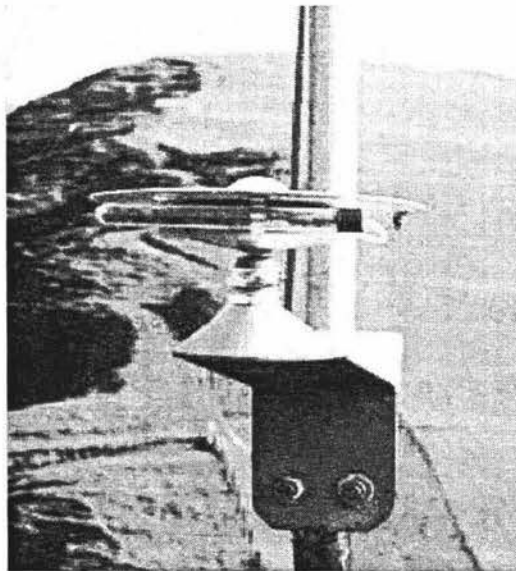

The solarimeter had a faulty seal, resulting in moisture entering the glass cover. This problem was not discovered until 12/08/1999 as the glass covers were not visible from ground level. The solarimeter was removed, dried out and returned to the site on

20/09/1999. Another check was carried out on 24/09/1999, which revealed the problem had not been solved. The solarimeter was again removed and dismantled to ensure that all the moisture was removed. It was reinstalled on 30/09/1999.

The difficulties faced with the solarimeter affected the quality of the collected data. The moisture on the glass covers reduced the amount of light reaching the solarimeter surface, so the data is an underestimation of the true resource by an unknown error.

7.1.1.3.1 Global Solar Radiation

The recorded global solar radiation is shown below (Figure 7.10). Average monthly values were calculated using hourly data obtained from the solarimeter. The value for August is based on only 16 days data from 01/08/1999 to 12/08/1999 and 20/08/1999 to 24/08/1999 due to the difficulties discussed above. Only four days of data were recorded for September, so an estimated figure of 2.6kWh/m²/day was used. This figure is close to that of April, which is the corresponding autumn month, but is slightly less as the spring months of August and October both received less radiation than their corresponding autumn months of May and March.

Figure 7.10: Global solar radiation in 1999

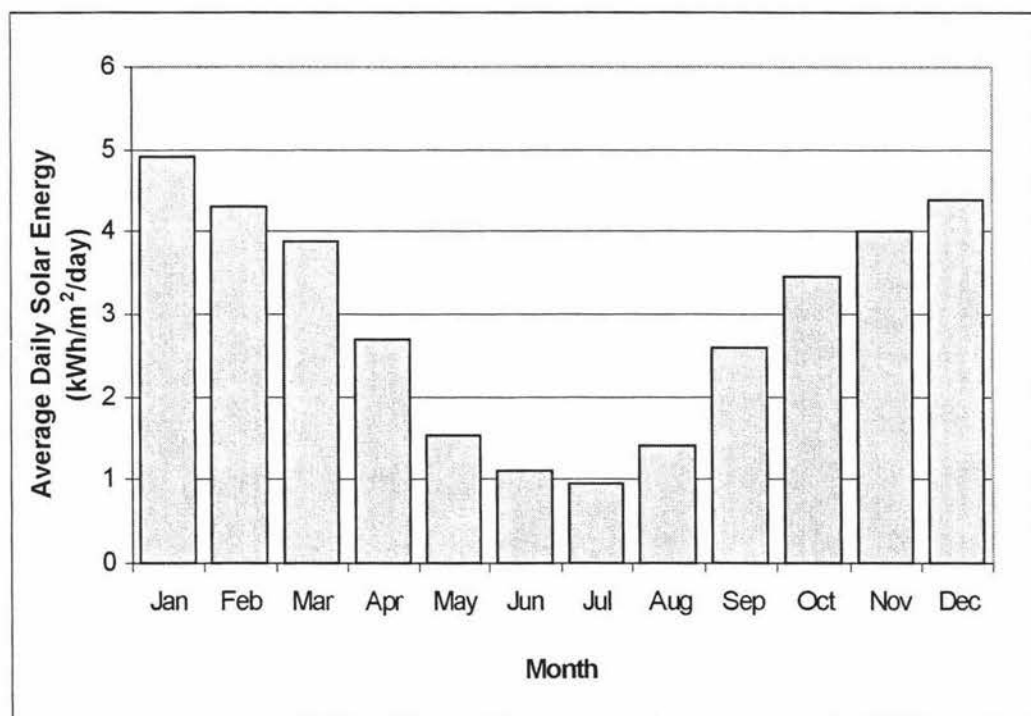

7.1.2 Electricity Demand

The electricity consumption profile for Totara Valley has been quantified using data from historical meter readings from Scanpower³, the lines company which maintains lines to the community. Weekly consumption profiles obtained from meters installed on the properties by Industrial Research Limited were also used as part of this study.

7.1.2.1 Scanpower Data

Three years of monthly consumption data for every meter in the community was provided. Methods used by Scanpower for generating a monthly account are:

1. meter reading – a Scanpower employee physically reads the meter;
2. interim estimate – a computer calculated reading based on historical consumption for that connection;
3. estimated reading – a computer estimated reading that only occurs when a meter reading can not take place due to illness or public holidays.

Of the readings provided by Scanpower 44% were meter readings, 49% interim reading, and only 7% estimated and not based on either real or historical data. From these readings the average monthly consumption was calculated for each meter, in a form suitable for entry into the computer model. The monthly consumption profile for the entire community was calculated by adding the total for each meter (Figure 7.11).

³ Scanpower retained electricity consumption data when it sold its energy business to Meridian Energy.

Figure 7.11: Monthly electricity consumption profile based on Scanpower data

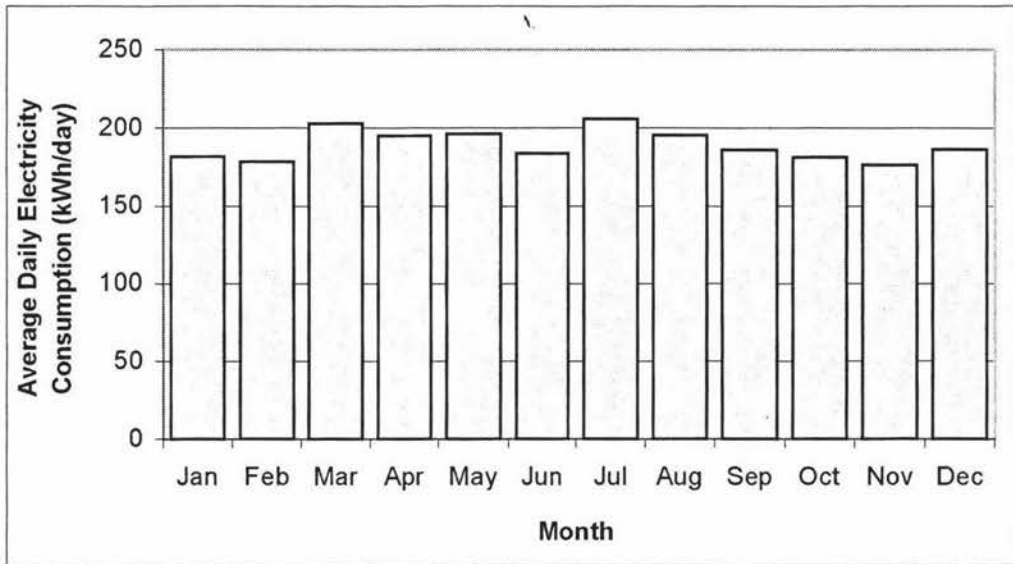

7.1.2.2 Load Profile Meters

In order to obtain peak and half hourly consumption profiles for the community, three types of electricity consumption data loggers were installed by Industrial Research Limited. The meters used were:

- Siemens (Figure 7.12) – 23 were installed between 20/09/1999 and 22/09/1999. One Siemens meter was used for every Scanpower meter in the community except those discussed below. These meters gave an overall total consumption in kWh between successive readings, and stored a half hourly weekly profile of electricity consumption. This profile was overwritten each week, so data was downloaded using a laptop computer and infrared cable on Wednesday afternoons every week from 20/09/1999 to 12/04/2000.

Figure 7.12: The author downloading data from Siemens meters

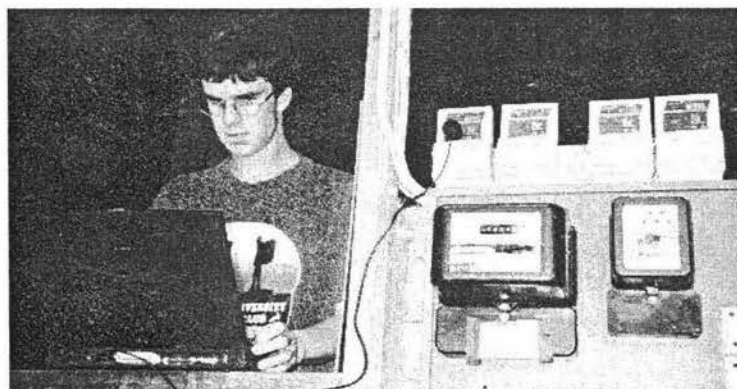

- Seaward – two of these meters were installed in the main residences of farms 1 and 2 between 20/09/1999 and 22/09/1999 to record the average current over three phases on a half hourly basis. They had the capacity to store data for up to three months so were checked only monthly until 12/04/2000. Two further meters were added on 13/10/1999 due to the failure of the EUM meters which had been installed earlier.
- Tiny Tag – three of these meters were used to profile the electricity consumption of electric ovens in the main residences of farms 1 and 3. They were installed on 21/09/99, and were checked monthly until 12/04/2000.
- EUM – two were installed to record half hourly consumption profiles for each connection in the main residence of farms 1 and 2. Difficulties retrieving data resulted in their replacement with Seaward meters three weeks later on 13/10/1999.

7.1.2.3 Load Monitoring Results

The daily profiles for the properties within the community averaged over the monitoring period from 21/09/1999 to 23/02/2000 are shown below (Figure 7.13).

Figure 7.13: Electricity consumption profiles for Totara Valley properties

(a) Average daily electricity consumption at Farm 1 over the spring/summer period

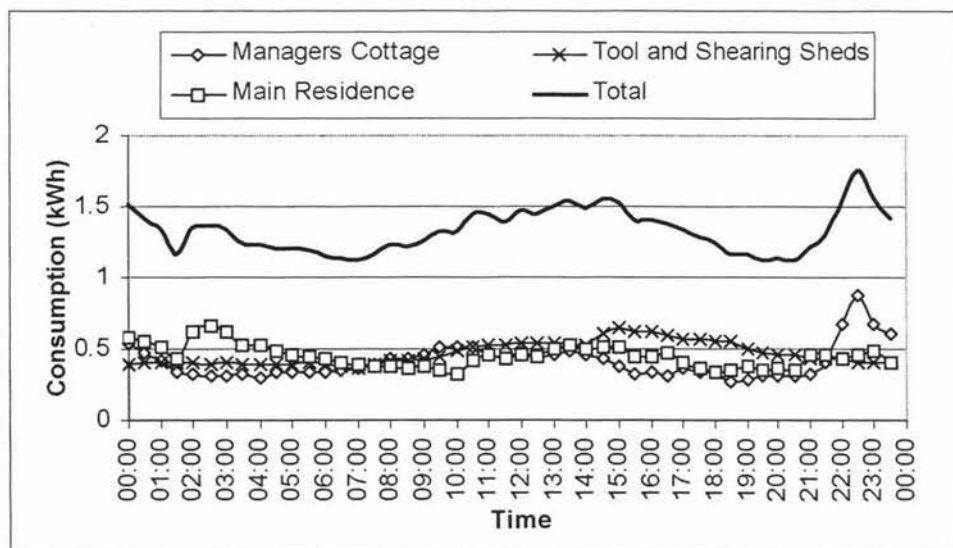

(b) Average daily electricity consumption at Farm 2 over the spring/summer period

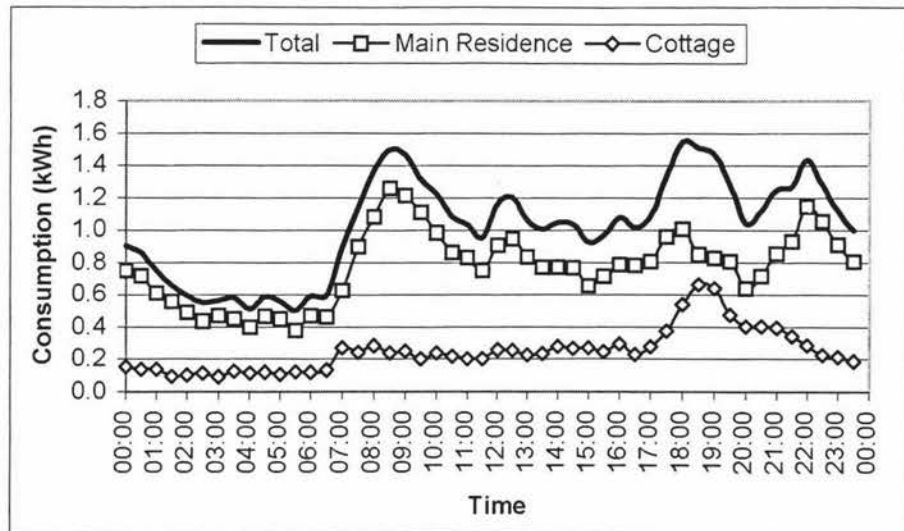

(c) Average daily electricity consumption at Farm 3 over the spring/summer period

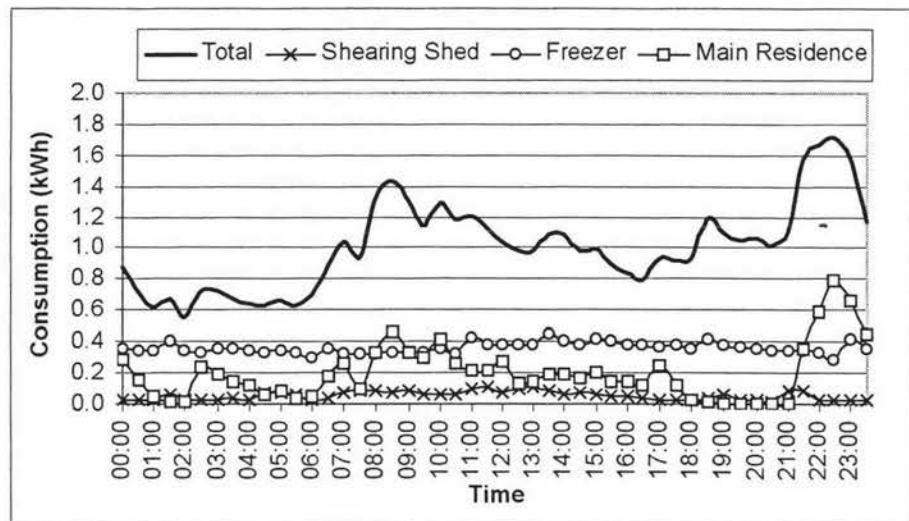

(d) Average daily electricity consumption at Farm 3's manager's cottage over the spring/summer period

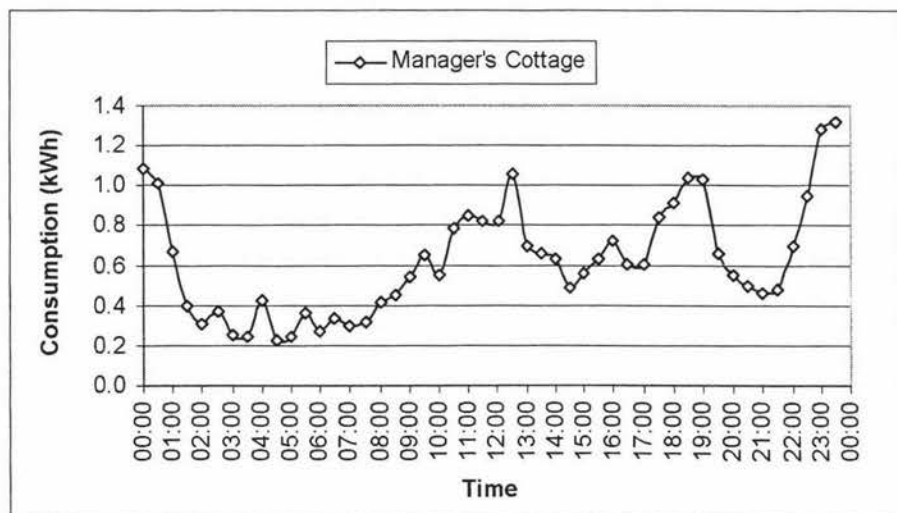

7.1.3 Energy Efficiency Options

The results of the consumption monitoring reveal some opportunities for energy efficiency.

The effects of night time hot water heating are obvious, with three of the four properties having consumption peaks between 10 and 10.30pm. The use of gas or solar hot water heating would reduce this peak load significantly.

Large walk in freezers were monitored at Farms 1 and 3, with the freezer at Farm 1 accounting for 16% of the farms total electricity consumption, and the freezer at Farm 3 accounting for 40%. This high consumption could be easily reduced by utilising a single community owned freezer in place of two individually owned freezers.

7.1.3.1 Shearing Loads

Shearing causes one of the major peak loads which occur on a sheep farm. The three shearing sheds were monitored within the community from 22/09/1999 to 23/02/2000. The consumption profiles for days of shearing at different farms are shown below (Figure 7.14 and Figure 7.15).

Figure 7.14: Electricity consumption during a day of shearing at Farm 1 (20/01/2000)

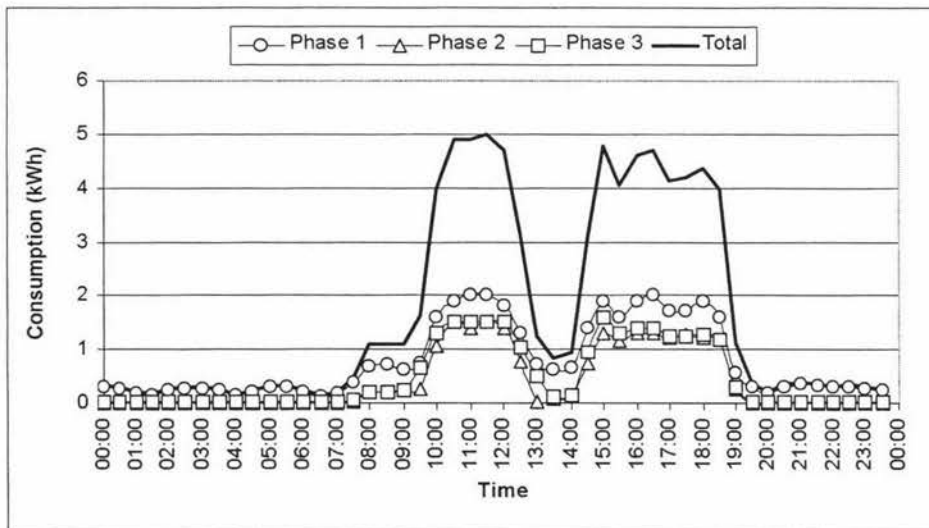
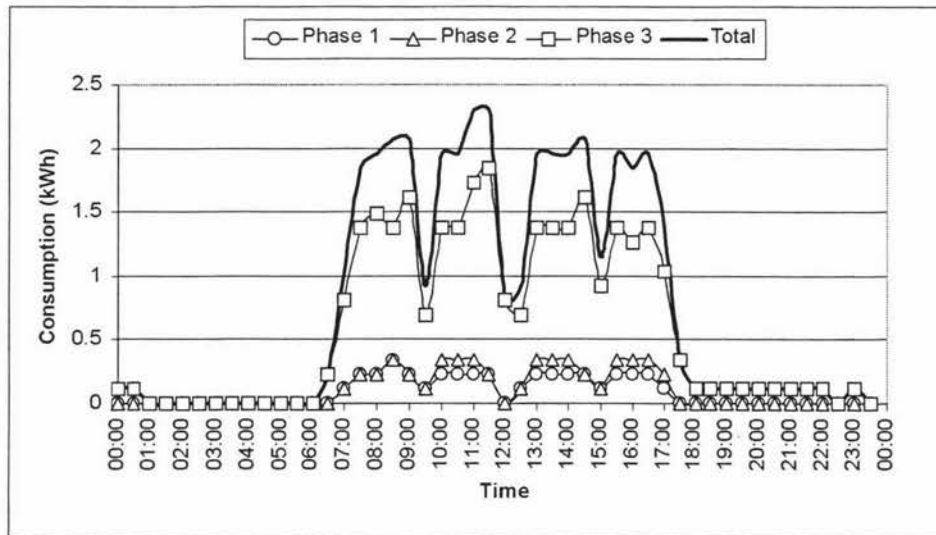

Figure 7.15: Electricity consumption during a day of shearing at Farm 2 (5/12/1999)



The profiles for the two farms both show a morning and afternoon shearing session, although the electricity consumption at Farm 2 dropped off considerably during morning and afternoon breaks (10am and 3pm) as well. The load at Farm 1 was evenly shared between the three phases, while the load at the Farm 2 is mostly carried by one phase. This suggests that all four shearing stalls were operating at Farm 1, while two of the four stalls were being used at Farm 2, resulting in a greater load being carried by a single phase.

The maximum half hourly average load and total daily consumption for the two sheds are shown below (Table 7.2). Both the maximum load and daily consumption for Farm 1 were 2.2 times greater than for Farm 2. This would suggest that twice the number of shearing stalls were being run at Farm 1 throughout the day.

Table 7.2: Maximum half hourly average load and total daily electricity consumption during shearing days at Farms 1 and 2

	Shearing Day		Average Non Shearing Day	
	Max. Half Hourly Average Load (kW)	Total Daily Consumption (kWh)	Max. Half Hourly Average Load (kW)	Total Daily Consumption (kWh)
Farm 1	10	81	0.5	5.6
Farm 2	4.6	38.3	0.05	1.2

7.1.3.2 Peak Loads

The peak instantaneous load of the community was not definable as the meters did not have the capacity to monitor and record these loads. However, it was roughly calculated using the half hourly data available. The maximum half hourly kWh consumption for a given meter (or combination of meters) was determined by adding the half hourly consumption of the meters, then divided by 0.5 hours to give the average load over that period (Equation 7.1).

$$x / 0.5 = y \qquad \text{Equation 7.1}$$

where: x = total consumption over a half hour period (kWh)
 y = average load over the period (kW).

The peak load was calculated for 14 different scenarios (Table 7.3).

Table 7.3: Peak loads calculated for analysis scenarios

Scenario Number	Included Properties	Peak Load (kW)
1	1,2,3,4	37.3
2	1,2,3,4	34.3
3	1,2,3	30.9
4	1,2,3	20.5
5	1,2	16.8
6	1,2	15.6
7	1	12.4
8	1	11.3
9	2	14.7
10	2	13.6
11	3	20.6
12	3	18.4
13	4	17.8
14	4	15.2

7.2 D'Urville Island

7.2.1 Energy Resources

7.2.1.1 Hydro

The hydro resource consists of a number of small streams distributed around the southern half of the island (refer Figure 9.2). Streams also exist in the northern half of the island, but they do not flow continuously, and are between four and five kilometres from the nearest dwellings. Streams at the southern end of the island are typically within 150m of the nearest dwelling. Four streams were finally identified on D'Urville Island as having potential for hydro development. These streams were selected for their proximity to the nearest dwelling and because they were known by residents to flow all year.

During a field trip to the island between 09/06/1999 and 11/06/1999 the flow rates were measured using the bucket method described in Section 2.4.5.1.1. The time taken to fill a 10 litre bucket was recorded, and this process was repeated until five similar times had been recorded. In some cases it was not possible to divert all of the flow into the bucket, so estimations were made as to what percentage of the flow was being diverted.

Measurements of the available head⁴ were made with a digital altimeter where the vegetation allowed travel up the stream bed. Where measurements were not possible they were estimated from the D'Urville Island topographic map (Table 7.4). The length of pipe required between the proposed intake point and turbine sites were also estimated from the topographic map due to the difficulties presented by dense vegetation.

Only one measurement was made of the streams due to the length of time required to visit all the sites and the cost of travel to sites that could only be accessed by boat.

⁴ Available head is the vertical distance from the intake point to the turbine.

Table 7.4: Head, flow and pipe length measurements for six D'Urville Island streams identified as being suitable for micro-hydro development

Grid Reference	Measured Flowrate (l/s)	Available Head (m)	Required Pipe Length (m)	
782 383	6.7	150	1200	
769 384	1.8	100	1000	
771 351	8.4	100	500	True Left Branch
810 336	6.7	150	600	True Left Branch
	13.3	150	850	True Right Branch
	20	80	850	Total Flow
851 384	10	150	650	

7.2.1.2 Wind

Monitoring of the wind resource was carried out over a four month period from 10/11/1999 to 01/03/2000. The monitoring site (Figure 7.16) was selected primarily because it was at the northern end of the island, where hydro generation is not possible.

Figure 7.16: (a) Wind monitoring equipment installed at the D'Urville Island site
(b) the view to the saddle where the anemometer was sited

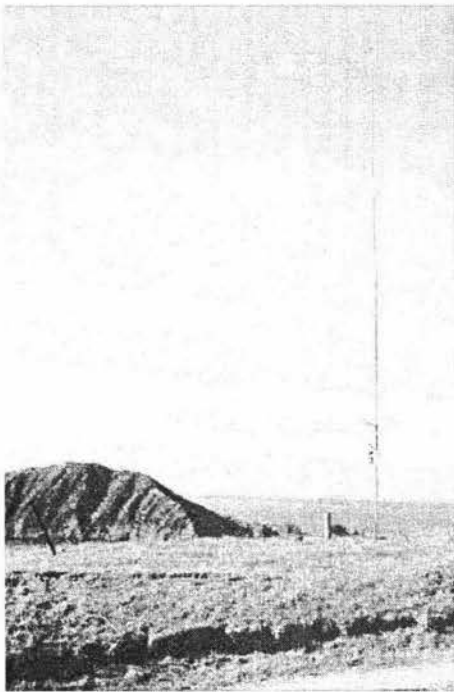

(a)



(b)

The anemometer tower was installed at the site on 08/06/1999, and checked four days later to ensure it was working correctly. The first visit to collect data was made by staff of Industrial Research Limited on 03/09/1999, when it was discovered that the battery had failed and no data had been collected during the previous three months. The battery was replaced during the next field visit on 10/11/99 and data was collected from then through to 01/03/2000 when stock damaged the anemometer tower.

7.2.1.2.1 Wind Speed

The mean annual wind speed during the monitoring period was 8.0 ms^{-1} with monthly variations (Figure 7.17). The least windy month was February with an average speed of 7.7 ms^{-1} , while the windiest month was November with an average speed of 8.7 ms^{-1} . The longest windless period recorded at the site was 15 hours, from 7pm on 15/01/2000 to 9am on 16/01/2000.

Figure 7.17: Monthly average wind speed for the D'Urville Island site

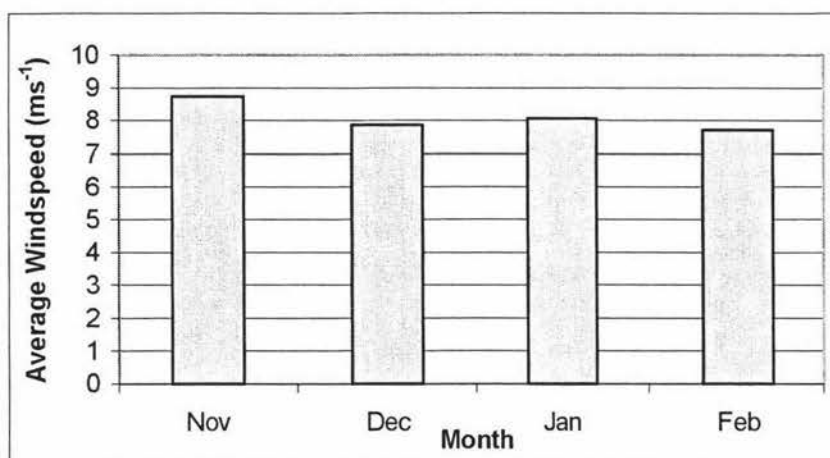

7.2.1.2.2 Wind Speed Distribution

As for Totara Valley, two Weibull distributions were produced using the methods described in Section 7.1.1.2.2 to match the wind speed distribution (Figure 7.18). The optimised Weibull distribution gave a better fit to the observed wind speed distribution with an R^2 value of 0.9725. The R^2 value for the calculated curve was 0.9435. The shape parameter for the optimised distribution was 1.85 and the scale parameter 9.73. These values are used to describe the wind speed distribution in the computer model.

Figure 7.18: Wind speed distribution and calculated and optimised Weibull curves for the period 10/11 1999 to 01/03/2000

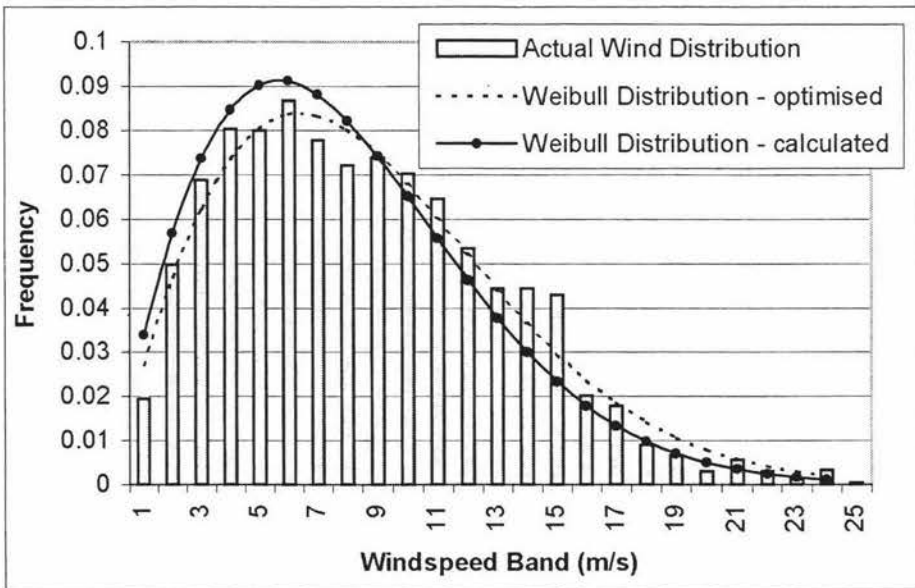

7.2.1.2.3 Wind Direction

Due to the funnelling effect of the surrounding hills the wind blew either from the west for 53% of the monitoring period or the north east (Figure 7.19).

Figure 7.19: Percentage of the monitoring period that the wind blew from each direction

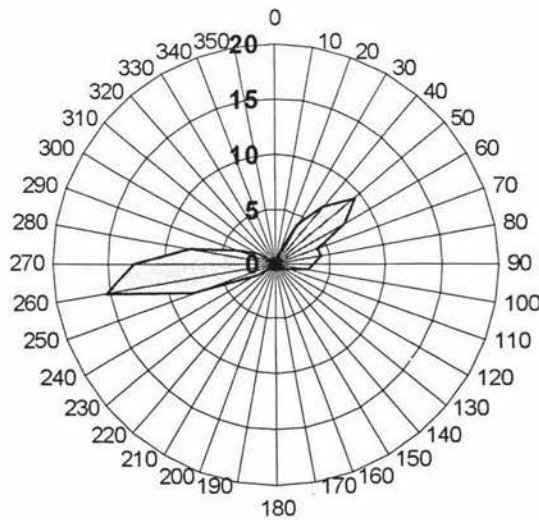

7.2.1.3 Solar

The solar resource was monitored between 10/11/1999 and 01/03/2000 using equipment similar to that described in Section 7.1.1.3. Figure 7.20 shows the monthly variation in the resource over this period. The highest daily global solar radiation recorded was 8.3 kWh/m² on 26/12/1999, and the minimum was 0.99 kWh/m² on 12/11/1999.

Figure 7.20: Average daily global solar radiation (10/11/1999 to 01/03/2000)

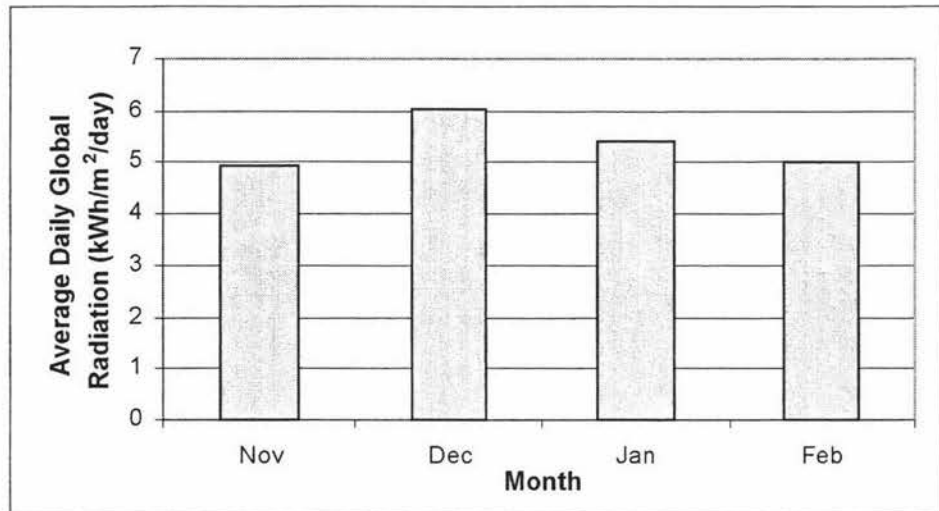

7.2.1.4 Correlation of Data with Nelson Airport Data

In order to obtain a full year of wind and solar data, a correlation analysis was carried out with data from the Nelson Airport automatic weather station (AWS) as provided by the National Institute of Water and Atmospheric Research (NIWA). This data included:

- Daily global solar radiation for the period 01/01/1990 to 08/03/2000
- Hourly average windspeed for the period 01/01/1999 to 31/12/1999
- Monthly profiles of hourly average windspeed for the period 01/1995 – 03/2000

Correlations were carried out for both wind speed and global solar radiation. Due to the specific effects of the surrounding topography on the wind direction an analysis was not carried out.

7.2.1.4.1 Wind Speed Correlation

A scatter plot was created using data from the period between 3pm 10/11/1999 to 12pm 31/12/1999, with hourly average wind speed data from D'Urville Island plotted on the y axis and from Nelson Airport plotted on the x axis (Figure 7.21).

Figure 7.21: Scatter plot of D'Urville Island and Nelson Airport hourly average wind speed data (10/11/1999 to 31/12/1999)

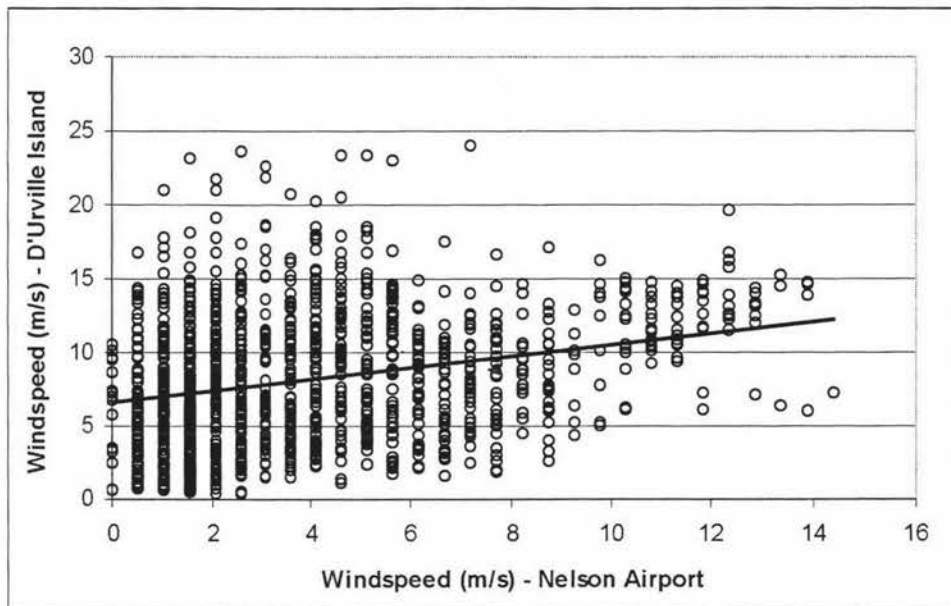

There is a very weak correlation between the two data sets (R^2 value = 0.0745), hence the average windspeed of 8 ms^{-1} was used as the annual average windspeed in the computer model even though this was only for a three month period.

7.2.1.4.2 Solar Radiation

A scatter plot was created using data from the period 11/11/1999 to 29/02/2000, with hourly average solar radiation data from D'Urville Island plotted on the y axis and from Nelson Airport plotted on the x axis (Figure 7.22).

Figure 7.22: Scatter plot of D'Urville Island and Nelson global solar radiation data (11/11/1999 to 29/02/2000)

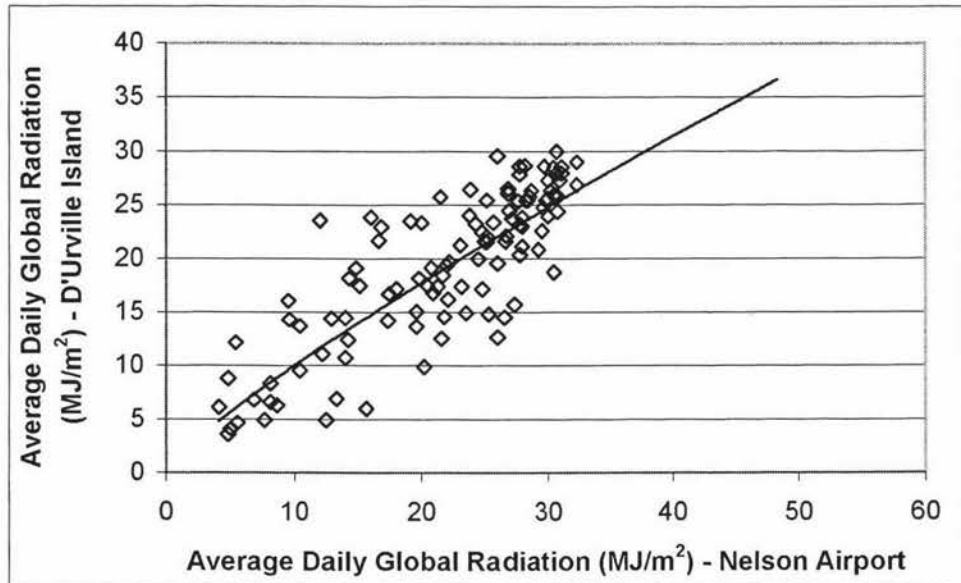

A series of R^2 values were calculated using trendlines of different functions to determine which produced the highest correlation (Table 7.5).

Table 7.5: R^2 values obtained using different types of trendlines

Trendline Type	R^2 Value
Linear	0.6866
Logarithmic	0.6514
Polynomial	0.6866
Power	0.6973
Exponential	0.6687

The best fit was achieved using a power function with the equation:

$$y = 1.5119x^{0.8223} \quad \text{Equation 7.2}$$

where y = D'Urville Island radiation
 x = Nelson Airport radiation

A full year of data for D'Urville Island was therefore taken from the 10 years of historical data from Nelson Airport using Equation 7.2 to give the average daily global solar radiation levels for the entire year (Figure 7.23).

Figure 7.23: Average daily global solar radiation levels for D'Urville Island, correlated from historical Nelson Airport data ($R^2 = 0.68$)

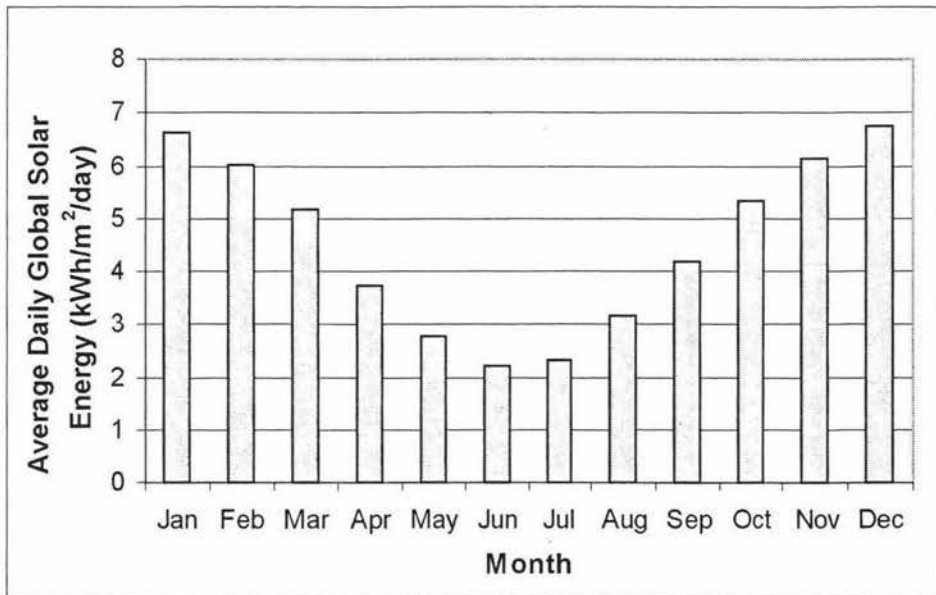

7.2.2 Electricity Demand

Electricity consumption was very difficult to quantify due to the lack of data available from Trust Power⁵, the energy company that supplies D'Urville Island. Due to the island's remote location readings are only taken annually, with estimated accounts being paid quarterly throughout the year.

Annual consumption data was obtained from Trust Power for 11 landowners who responded to the questionnaire and were willing to be a part of community owned renewable energy scheme. This data was then combined with responses given in the questionnaire to estimate the consumption profile.

Load metering was carried out on four properties (Figure 7.24) using 16 Siemens meters installed by Industrial Research Limited staff on 03/09/1999 and 04/09/1999.

⁵ The electricity consumption records were passed over to Trust Power when Marlborough Electricity sold their energy business in 1999.

Figure 7.25: Annual electricity consumption of 11 D'Urville Island landowners willing to be part of a community scheme

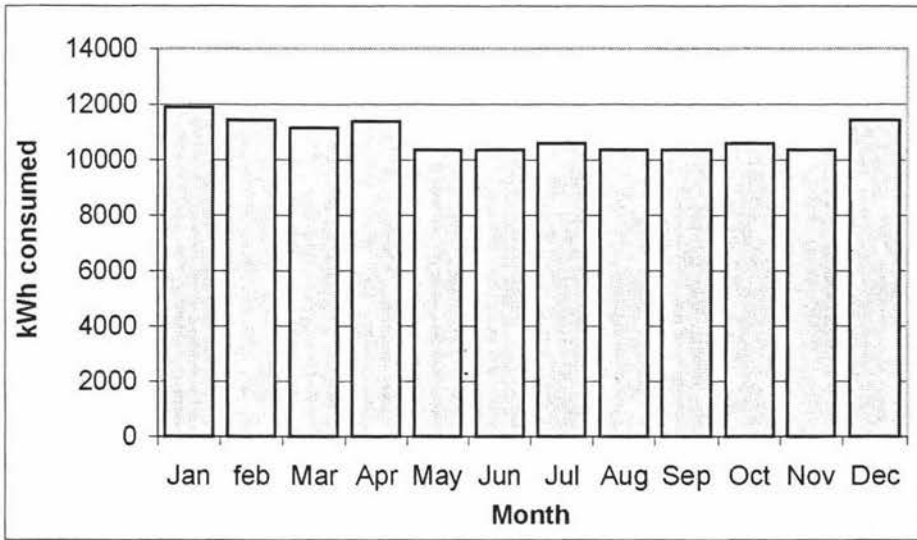

This profile differs from that obtained for the Totara Valley site (which had higher consumption over the winter period) due to differences in seasonal requirements. The population swells on D'Urville Island over the summer months due to increased tourist activity and visitors to the island, resulting in a higher demand over this period.

7.2.2.1 Peak Loads

Peak loads on D'Urville Island were not obtainable due to the small amount of data recorded by the meters installed on the island. In order to estimate the peak loads of the properties and buildings included in the analysis, monitoring results from similar properties, and combinations of properties, in the Totara Valley have been used. These estimations are based on the number of people living on a property and the property usage. This method has many inaccuracies associated with it, but with no real data available it is considered to be the best option. The estimated peak loads for the analysis scenarios are given in Section 9.2.1.

8 Renewable Communities – Computer Model

The Renewable Communities model is described by the inputs required, the reasoning used in selecting the components of a renewable energy scheme, and the design procedures used to optimise the results. The model is divided into six sections which focus on a particular area of renewable energy system design:

- Electricity demand
- Hydro resource and technology
- Wind resource and technology
- Solar resource and technology
- Storage, transmission and site works
- Analysis options

A detailed description of the calculations and formulae used by the model is given in Appendix A.

8.1 Electricity Demand

This section of the model deals with the present consumption of the community or individual customer. The tasks performed in this section of the model are:

- to detail the monthly profile of power consumption for the community;
- to calculate the cost of supplying electricity through the national grid, based on current tariffs;
- to calculate the difference in electricity consumption when electric hot water heating is excluded from the consumption profile.

8.1.1 Tariffs

The tariff structure that relates to the customer or community under consideration is entered on a standard form using tariffs obtained from the local energy and network suppliers (Figure 8.1).

Figure 8.1: Energy and network tariff input page

Energy and Network Tariffs
✕

Use this form to enter the tariffs that apply for the community. Tariff names differ between suppliers, so take more note of the units (rather than the name) for each tariff. If any tariff does not apply, leave the cell blank.

Domestic Connections

Energy Charges

Anytime Energy (c/kWh)	6
Water Heating Energy (c/kWh)	6
Night Energy (c/kWh)	6
Metering or Service Charge (c/mth)	290

Network Charges

Energy Supply Charge (c/day)	65
Anytime Line Charge (c/kWh)	4.45
Water Heating Line Charge (c/kWh)	2
Night Only Line Charge (c/kWh)	2

Commercial Connections

Energy Charges

Anytime Energy (c/kWh)	6
Water Heating Energy (c/kWh)	6
Night Energy (c/kWh)	6
Metering or Service Charge (c/mth)	290

Network Charges

Daily Supply Charge (c/day)	
KVA Charge (c/KVA/mth)	235
Average KVA rating (default = 8)	14
Anytime Line Charge (c/kWh)	4.5
Water Heating Line Charge (c/kWh)	2.2
Night Only Line Charge (c/kWh)	2.2
Corporate Services Charge(c/mth)	690

8.1.2 Electricity Consumption

The electricity consumption demand for the community is inputted at one of three levels, depending on the consumption data available. These options are:

- **Individual Members:** For less remote communities where monthly data is available for each meter in the community. This option gives the most flexibility in terms of system optimisation, but it can be difficult to acquire the required data.
- **Entire Community:** monthly data for every meter in more remote communities may not be available. However, it should be possible get the total consumption for the community on the different tariffs from the energy retailer. The time taken to enter the data for this option is shorter, but there is less flexibility in terms of design optimisation.
- **New Development:** This option is included to allow an analysis to be carried out for a new development that is not currently grid connected. This gives the model design capacity beyond the scope of existing grid connected communities.

8.2 Hydro Resource and Technology

All inputs for the hydro resource and the technology section entered on the Hydro Analysis Input Page (Figure 8.2)

Figure 8.2: Hydro analysis input page

Hydro Analysis Input Page
✕

Design Inputs

Design Head (m)	100	
Available Flowrate (l/s)	8.2	
% flowrate allowed under project consent	90	
Pipe Length from Intake to Turbine (m)	824	
Distance to Point of Use (m)	500	
Annual Operation and Maintenance Costs	2	% of capital costs
Design Life of Turbine (default = 20 years)	20	

Resource Consents

Cost of consents (\$)		
Water Permit Required	<input checked="" type="checkbox"/>	
Land Use Permit Required	<input checked="" type="checkbox"/>	
Discharge Permit Required	<input checked="" type="checkbox"/>	

Pipe Size Calculation

Roughness Coefficient - select from table below	0.000003	Use Own Pipe <input type="checkbox"/>
Allowable Headloss (%)	10	

Pipe Roughness Coefficients

	Good (5yrs)	Normal (5-15 yrs)
Concrete	0.00006	0.00015
PVC, HDPE, MDPE, Glass Fibre	0.000003	0.00001
Mild steel - Uncoated	0.00001	0.0001
Mild steel - galvanised	0.00006	0.00015
Cast Iron	0.00015	0.0003

OK

8.2.1 Calculations Performed

Once all the data has been entered, an iterative calculation is carried out to determine the pipe size required to deliver the stated flow with the required head loss. This calculation takes into account the type of pipe that is being used and its age. The model also has the option of using pipe supplied by the customer, if they can source cheaper

pipe. If this option is used, the pipe diameter and roughness coefficient are also required.

The type of turbine required for the specified resource is calculated on the basis of the available head. Three types of turbine are used in this model, and their selection is based on the head limits shown in Table 8.1.

Table 8.1: Head limits used to determine micro hydro turbine type

Turbine Type	Head Limits (m)
Propeller	<10
Crossflow	10 – 50
Pelton	>50

8.2.2 Turbine Suppliers and Cost

Most hydro turbine manufacturers do not have a standard price for a given turbine rating as the dimensions of the turbine depend on the head/flow combination. This makes it impossible to include a turbine database into the model, so a list of suggested suppliers is included that can be contacted for quotes on turbines for specific conditions. The model will determine which type of turbine is required and show the suggested manufacturers, but it is up to the model user to collect pricing information to input.

The turbine price must include the cost of the turbine itself, the control gate, any gearing required, and the alternator. The cost of the controller is considered separately.

The manufacturers included in the model are those that Powerflow Ltd. have used in the past and would like to continue to use. Once quotes have been obtained the price is then manually entered into the model.

8.2.3 Resource Consents

Resource consents under the Resource Management Act (1991) are generally always required for hydro schemes as they involve the disturbance of natural streambeds. The type of consents that will be required is dependent on the applicable regional or district plan and include:

1. Water Permit – required if water is going to be removed from the streambed.
2. Land Use Consent – required if extensive site works are undertaken, including the building of dams, channels, silt basins and penstock anchors.
3. Discharge Permit – required to cover the water being put back into the river.

The model user will need to work with the appropriate local body to determine which consents will be required. The cost of these consents are included in the financial analysis.

8.3 Wind Resource and Technology

This section of the model is concerned with the wind resource and the technology used to harness this resource. All the data for the analysis is entered into the model using the Wind Analysis Input Page (Figure 8.3)

Figure 8.3: Wind analysis input page

The wind analysis can be carried out using either monthly or annual data.

Select the data type that you are are using

Monthly Averages

Weibull Shape Parameter (Default = 2)

Surface Roughness Coefficient (Z₀) 0.15

Turbine Design Life (default = 20 yrs) Build Own Tower

Anemometer Height (Default = 10m) Height of Own Tower (m)

Operation and Maintenance Costs (%) Cost of Own Tower (\$)

% of capital costs (default = 2)

Average Windspeed (m/s)

January	February	March	April	May	June
5.4	6.1	5.2	5.9	5.6	5
July	August	September	October	November	December
5.6	4.5	5.2	5.9	6.4	5.5

OK

8.3.1 Required Inputs

The wind resource analysis can be carried out on either an annual or monthly basis, depending on available data. There are five inputs that are common to both levels of analysis.

1. Weibull shape parameter – this parameter determines the shape of the wind speed distribution used in the analysis. (For a more detailed description on the wind analysis see Appendix A). Patel (1999) stated that at most sites this parameter = 2, so this is the default value. Alternative values can be used if a value has been calculated from site specific data.
2. Surface roughness coefficient – describes the terrain in which the wind turbine will operate. The user can select the description that best suits the proposed site from a drop down list (Table 8.2).

Table 8.2: Surface Roughness Coefficients used in the model

Terrain Description	Surface Roughness Coefficient
Cities with very tall buildings	0.4
Cities and large towns	0.35
Small towns	0.3
Town outskirts	0.28
Woodland and forest	0.28
Farmland with many trees, hedges and a few buildings	0.25
Farmland with scattered trees and hedges	0.23
Farmland with crops or tall grass	0.2
Farmland with isolated trees	0.17
Farmland with uncut short grass	0.15
Farmland with cut grass	0.13
Coastal areas with off sea winds	0.12
Lake, ocean and smooth hard ground	0.1

(Source: Patel, 1999)

3. Turbine design life – this value is used in the financial analysis. A commonly accepted estimate of turbine life is 20 years (Gipe, 1993), so this is suggested as the default value.
4. Anemometer height – if wind data has been collected at the site, the height of the anemometer will be known. If data from NIWA (National Institute for Water and Atmospheric Research) is being used the standard anemometer height of 10m can be used.
5. Operation and maintenance costs. – this is the annual cost required to keep the wind turbine operating to its full potential. Gipe (1993) stated that “there is a consensus

within the wind industry that maintenance will cost about 2 percent of the total wind system cost annually". This figure is therefore suggested as the default value.

6. Windspeed – the average windspeed over the month or year, depending on the analysis being used in metres per second.
7. Use own tower – there is the option for the customer to use his/her own tower if they choose to. If this option is selected the calculations will be based on this height, rather than the manufacturer's supplied tower height.

8.3.2 Wind Turbine Database

The expected output of the turbines is based on the power curves of commercially available wind turbines. In order to achieve this a database of wind turbines of various sizes has been developed. For each turbine in the database the following information is required:

- Turbine rating
- Cut in Wind Speed
- Rated Wind Speed
- Cut out Wind Speed
- Hub Height
- Cost of Turbine
- Cost of Tower
- Whether or not a controller is included in the price
- Cost of Controller

The power curve for each turbine from 0 – 30ms⁻¹ is also required. Turbines can easily be deleted and added from the database if required.

8.3.3 Wind Turbine Selection

The appropriate wind turbine is selected on the basis of minimising the Net Present Value (NPV) of the turbine(s). This is achieved by calculating the annual or monthly energy output of the turbines and comparing this to the energy requirements given in the Electricity Demand section. For each turbine in the database the number of turbines required to meet the demand is calculated, along with the NPV. The turbine model that produces the minimum NPV is then selected.

8.4 Solar Resource and Technology

All the data for the analysis of the solar resource and the technology required to harness this resource is entered into the model using the Solar Analysis Input Page (Figure 8.4).

Figure 8.4: Solar analysis input page

Site Characteristics	
Site Latitude (+ve if site is north of equator, -ve if site is south of the equator)	-40.4
Site Altitude (m)	340
Panel Orientation	N
Annual Maintenance Cost (% of panel capital costs)	1
Panel Life Expectancy (default = 20 yrs)	20
Panel Efficiency (default = 13%)	13
Ground Reflectivity - choose the best site description:	Dark Building Surfaces (eg: red brick, dark paints)

Solar Resource Data			
Select which type of data you are entering (Total (or global) Radiation or Sunshine Hours): Sunshine Hours (hrs)			
January	4.91	July	0.96
February	4.3	August	1.42
March	3.89	September	2.6
April	2.7	October	3.45
May	1.53	November	4
June	1.1	December	4.38

8.4.1 Required Inputs

The solar resource analysis can be carried out using either global solar radiation data, or sunshine hour data, depending on what data is available. There are seven inputs that are common to both types of analysis. These are:

1. Site latitude – defines the distance of the site from the equator. Positive values are in the Northern Hemisphere, while negative values are in the Southern Hemisphere. This value can be found on any map of the area.
2. Site altitude – the elevation of the site above sea level. This can be found on a topographic map of the area.

3. Panel orientation – the direction the panels will face to optimise solar energy collection. This will usually be towards the equator (south in the Northern Hemisphere - north in the Southern Hemisphere). However, if the surrounding topography or nearby trees and buildings will block the sun for significant periods during the day, it is better to face the panels in the direction from which most of the solar radiation will come.
4. Annual maintenance costs – this is the annual cost to keep the photovoltaic array working to its full potential. Photovoltaic arrays only require cleaning to keep them functioning properly as there are no moving parts, so maintenance costs are minimal. A value of 1% of the capital cost should be used for contingencies.
5. Panel life expectancy – this is the expected life of the photovoltaic array. Solarex warranty their panels for 20 years (Solarex Product Catalogue, 1999), so this is used as the default value.
6. Panel efficiency – this is the efficiency at which the panel converts solar energy into electrical energy. As the model uses the Solarex brand of panels, their stated efficiency of 13% is used in the model.
7. Ground reflectivity – this is the ability of the surface around the array to reflect light back onto the array. The model user can select this value from a drop down list that gives a selection of different surfaces and their reflectivity. These values are given in Table 8.3.

Table 8.3: Ground reflectivity values used in the model

Surface Type	Ground Reflectivity
Snow	0.75
Water Surfaces	0.07
Soils	0.14
Earth Road	0.04
Weathered Concrete	0.22
Dry Grass	0.20
Green Grass	0.26
Crushed Rock	0.20
Dark Building Surfaces (e.g.: red brick, dark paints)	0.27
Light Building Surfaces (e.g.: light brick, light paints)	0.60

(Source: Yeaman, 1998)

8.4.2 Solar Panel Database

The panel sizing is carried out using specifications for the Solarex range of solar panels. The specifications stored within the model (which need to be kept up to date by the model user) are:

- Panel Rating
- Panel Length and Width
- Panel Cost

8.4.3 Panel Sizing

The model optimises the panel area required to meet the electricity demand specified in the Electricity Demand section of the model. The cost of the array is calculated using a dollars/rated Watt relationship calculated from the supplied panel data.

8.5 Storage, Transmission and Site Works

Optimisation of the storage and transmission requirements is undertaken in this section, along with the calculation of the cost associated with remaining connected to the national grid. The aspects of storage which are considered in this section are the batteries and the inverter. The cost of site works associated with each of the resource technologies are also specified in this section with the data required being entered in the Storage and Transmission, and Site Works Input Pages (Figure 8.5).

Figure 8.5: Storage and transmission and site works input pages

The figure shows two side-by-side software input windows. The left window, titled 'Storage and Transmission Input Page', contains two sections: 'Batteries' and 'Transmission'. The 'Batteries' section has seven input fields with the following values: Number of days storage required (4), Maximum battery depth of discharge (50), Inverter Efficiency (85), System Voltage (24), Wintertime Average Temperature (10), and Annual Maintenance (1). The 'Transmission' section has five input fields: Cost per km of existing infrastructure (30000), Age of existing infrastructure (13), Expected life of existing infrastructure (50), Annual Operation and Maintenance Costs (empty), and Present Lines Company (Scanpower). The right window, titled 'Site Works', has a heading 'Insert the approximate costs of the site works in the cells below. (NZ\$)'. It contains three sections: 'Hydro' with Intake, Dump Loads, and Power House; 'Wind' with Concrete Foundation and Tower Anchors; and 'Solar' with Panel Framing. A 'General' section at the bottom has Wiring and Circuit Board. Both windows have an 'OK' button at the bottom right.

8.5.1 Inputs Required

(a) Battery sizing requires seven inputs from the model user.

1. Number of days storage required – based on the expected maximum period that no incoming energy would be received by the system.
2. Maximum battery depth of discharge (DOD) – the level of discharge that the batteries should be taken to in one charging cycle. A high DOD will work the batteries harder resulting in a shorter lifespan, while a low DOD will require more batteries to meet the load, resulting in higher capital costs. The default DOD is 50%, as this is most commonly used by system designers (NAWS, 2000). The model user has the option of changing this value.
3. Inverter efficiency – the efficiency at which the inverter inverts DC electricity to AC electricity. The inverting process is not 100% efficient, and this needs to be accounted for in the sizing of generating equipment. A default figure of 95% is suggested (Trace Technologies, 1999).
4. System voltage – the voltage at which the DC side of the system will operate. A value of 24V is usually recommended as this reduces the number of batteries required, as well as the capital cost.

5. Wintertime average temperature – the performance of a battery is affected by temperature. The relationship between temperature and the battery capacity correction factor (C.F.) is given by:

$$\frac{(C.F. = 1.1886T + 71.143)}{100}$$

Equation 8.1

where T = the average wintertime temperature (°C).

6. Battery make – the battery database can store three makes of battery and their model specifications. A list of three suppliers for each battery make is also given. The model user can then choose which make of battery they would like to use and ascertain who can supply the batteries.
7. Annual Maintenance Costs – this is the annual costs of maintaining the batteries to ensure long life. These costs are minimal if the appropriate charge controller is used, so a figure of 1% is suggested as the default value.

(b) The transmission side of the model requires four inputs from the user.

1. Cost per km of existing infrastructure that the lines company owning the network would charge the community. This can be obtained from the applicable lines company.
2. Age of existing lines which supply the community. This is required to determine the useful life expectancy.
3. Expected life of existing infrastructure is the overall life expectancy for the existing lines and poles. The lines company will be able to provide a knowledgeable estimate for the location.
4. Annual operation and maintenance costs of maintaining the line to a safe standard. The lines company will be able to provide an estimate for this value.

Sizing of the batteries and inverter is based on present day prices and specifications. In order to achieve this two databases have been set up to allow the user to enter a range of batteries and inverters from three manufacturers.

(c) Site works costs are often hard to define at the feasibility stage, but estimates can be given if desired. The sites works that are considered are:

- Hydro – intake structure and dump loads
- Wind – concrete foundation and tower anchors
- Solar – panel framing and installation
- General – miscellaneous wiring and circuit boards

8.6 Analysis

8.6.1 Analysis Options

The analysis options available to the user depend on the level of data entered in the Electricity Usage section. If data for each connection is available the user can remove or add customers from the community scheme, as well as include or exclude the electricity required for water heating.

If data for the entire community only is available, the user can still include or exclude the electricity required for hot water.

For a new development, it is expected that the user will have minimised the loads already, so there is no flexibility in this option.

8.6.2 System Optimisation

The final action of the model is to optimise the system by varying the contribution of wind and solar energy. The contribution of a hydro turbine is included in the analysis, but is not optimised as the equipment used to harness the resource is not modular. The power to be delivered from wind turbines and solar panels is calculated by subtracting the energy produced by hydro turbine from the total energy requirement. The model then uses an Excel Solver function to determine what combination of wind turbines and solar panels will meet this power requirement whilst minimising the Net Present Value of the system.

8.6.3 Analysis Report

A summary of the optimised design can be printed for comparison with other design scenarios (Figure 8.6).

Figure 8.6: Example of a summary report prepared by the computer model



Renewable Communities

Scenario Summary

Community / Client Name: <u>Totara Valley</u>	Contact Phone: _____
Contact Person: _____	Contact E-mail: _____
Contact Address: _____	Date: <u>26/04/00</u>
Type of Analysis: <u>Individual Members</u>	

ENERGY RESOURCES AVAILABLE: **Hydro** **Wind** **Solar**

Hydro	Type of Turbine: <u>Pelton</u>	Penstock Length (m): <u>718</u>
	Turbine Rating (kW): <u>2.10</u>	Penstock Diameter (m): <u>0.051</u>
Wind	Turbine Model: <u>Whisper 3000</u>	Controller Included (Y/N): <u>Y</u>
	Number Required: <u>2</u>	Data Type (Annual/Monthly): <u>Monthly</u>
Solar	Panel Area (m ²): <u>Not Required</u>	Rating of Panel array (Wp): _____
	Optimised Panel Slope (°): _____	
Storage & Network	Battery Make: <u>Trojan</u>	Inverter Make: <u>Trace</u>
	Battery Model: <u>T105</u>	Inverter Model: <u>DR2424E</u>
	Number Required: <u>280</u>	Number Required: <u>5</u>
	Days Storage Provided: <u>4</u>	Length of Network Lines (km): <u>0</u>

ECONOMICS

Total NPV (SNZ): <u>238858</u>	c/kWh produced: <u>68.2</u>
Total Capital Cost (SNZ): <u>128111</u>	Water Heating Included (Y/N): <u>Y</u>
Annual Cost to Community/Customer (NZ\$): <u>24328</u>	
Annual Cost of maintaining existing grid connection (NZ\$): <u>3961</u>	

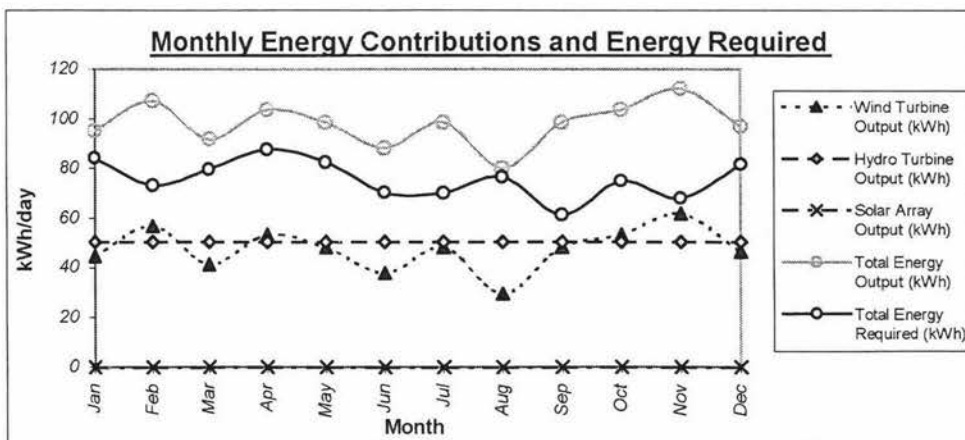

9 Results and Recommendations

Details of the analyses carried out using the Renewable Communities computer model are given, and the results summarised. The options for the communities are presented along with associated costs and recommendations.

9.1 Totara Valley

Fifteen different scenarios were analysed for the Totara Valley community using electricity consumption data for individual members (Table 9.1). The variables used in the analysis were:

- number of properties to be supplied by the system;
- inclusion or exclusion of electric water heating;
- length of line required to connect properties – estimated from a topographic map;
- peak loads – determined from consumption monitoring (Section 7.1.2)
- availability and magnitude of energy resources⁶.

The properties 1,2,3 and 4 relate to the numbering of farms shown in Figure 7.1. Property 4 is the manager's cottage of Farm 3.

Table 9.1: Scenarios considered for the Totara Valley community analysis

Scenario Number	Included Properties	Water Heating Included	Length of Line (km)	Peak Load (kW)	Available Energy Resources
1	1,2,3,4	Yes	2.5	37.3	H, W, S
2	1,2,3,4	No	2.5	34.3	H, W, S
3	1,2,3	Yes	1.75	30.9	H, W, S
4	1,2,3	No	1.75	20.5	H, W, S
5	1,2	Yes	0.25	16.8	H, W, S
6	1,2	No	0.25	15.6	H, W, S
7	1	Yes	0	12.4	H, W, S
8	1	No	0	11.3	H, W, S
9	2	Yes	0	14.7	W, S
10	2	No	0	13.6	W, S
11	3	Yes	0	20.6	W, S

⁶ In Table 9.1 and Table 9.4 the available energy resources are identified as: H = hydro; W = wind; S = solar.

Table 9.1 continued

Scenario Number	Included Properties	Water Heating Included	Length of Line (km)	Peak Load (kW)	Available Energy Resources
12	3	No	0	18.4	W, S
13	4	Yes	0	17.8	W, S
14	4	No	0	15.2	W, S
15	1,2,3,4	Yes	0	0	H,W,S

Scenario 15 represents the cost of generating electricity while being connected to the grid, although the line charges associated with grid connection are not included. It was assumed that the grid would provide the necessary storage and transmission, so the number of days storage required, the peak load, and the length of transmission line were set to zero.

9.1.1 Model Inputs

The available energy resources and electricity consumption profile for Totara Valley have been quantified in Section 7.1.1 and Section 7.1.2. The other inputs used in the model for each scenario are detailed in Appendix C.

9.1.2 Results and Recommendations

The financial results of the analyses are given in Table 9.2.

Table 9.2: Cost of grid connection and renewable energy for Totara Valley scenarios

Scenario Number	Annual Cost of Grid Connection (\$)	Annual Cost of Supplying Renewable Electricity (\$)	c/kWh from Renewable Energy
1	11993	121753	106.6
2	10381	85316	97.4
3	10760	104242	91.8
4	9433	73246	92.7
5	7244	67059	94.9
6	6228	42351	79.7
7	3961	24328	68.2
8	3384	8975	40.5
9	3283	47613	104.4
10	2844	38104	144.2
11	3516	35624	102.9
12	3205	27531	106.1
13	1232	19331	111.8
14	948	10828	125.2
15	11993	18374	16.1

For each analysis the annualised cost over a 20 year period of the optimised renewable energy system and the current grid connection is given. The annual cost of a grid connection is the annualised cost of supplied energy and network charges, using the tariff structure described in Table C.1. For analyses that do not include electric water heating, the cost of energy and network charges associated with water heating connections are excluded. The annual cost of renewable energy is the annualised cost of running an optimised renewable energy scheme, including operation and maintenance costs. The cost per kWh for electricity supplied from renewable resources is also given. The summary sheets produced by the model for each scenario are included in Appendix D.

The present cost of electricity supplied to Totara Valley through the national grid is considerably lower than that supplied with a stand alone community owned scheme. The costs of owning and maintaining the distribution line, which are currently met by Scanpower, make the cost of a stand alone scheme prohibitive. The results of scenarios 1 and 15 show that for a stand alone scheme that includes all community members, 85% of the cost of the scheme is taken up with storage and transmission equipment.

The best renewable energy option for each member was identified by calculating the cost per member of the different scenarios (Figure 9.1). These costs were determined by allocating a percentage of the scenario cost to each member (Table 9.3), based on the distribution of the annual electricity consumption (including water heating) between members.

Table 9.3: Ratio of scenario cost allocated to each farm

Included Properties	Scenario Used	Farm 1	Farm 2	Farm 3	Farm 3 Manager
1 – 4	1	0.34	0.31	0.25	0.10
1 – 3	3	0.38	0.28	0.34	-
1 – 2	5	0.58	0.42	-	-
Individual	7,9,11,13	1	1	1	1

Figure 9.1: Cost of scenarios to each farm (including water heating))

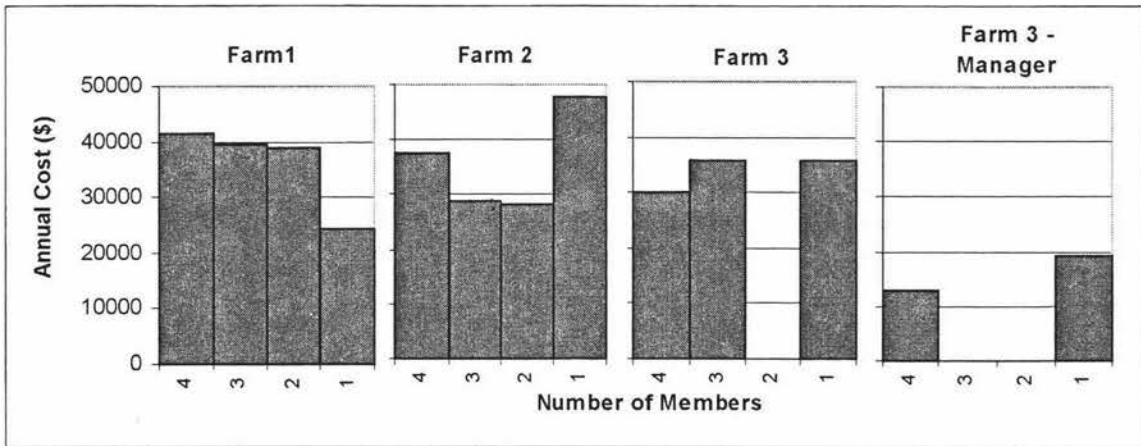

These results show that different sized schemes are more cost effective for different members of the community. However, for every community member a joint scheme with one or more other members is the most cost effective option. Apart from Member 1 (who has the option of generating electricity from a hydro resource in an individually owned scheme), an individually owned scheme using the wind and solar resource is the most expensive option. The costs of renewable energy generation can therefore be reduced if a community works together by sharing their resources.

Scenario 15, which used all three resources, shows that the cost per unit of generating sufficient electricity to meet the consumption demand from renewable sources at the Totara Valley site is 16.1 c/kWh if connected to the grid. This cost does not include any storage and transmission, as the exact costs of this for a grid connected system would depend on the agreement reached between the lines company and the community. The average unit cost of electricity supplied by the national grid was calculated to be 16.9 c/kWh. This result was achieved by dividing the annualised cost of grid connection for all community members by their combined annual electricity consumption.

These results show that the existing national grid supply remains the cheaper option for the Totara Valley residents at present. A grid disconnected scheme is also an option, but further reductions in the cost of generating electricity from renewable resources, or an increase in the costs of grid supply, would need to occur to make this cost effective.

9.2 D'Urville Island

A total of 11 grid connected land owners were identified as being willing to be part of a renewable energy scheme with other community members. 34 scenarios have been investigated for the island, based on the geographical distribution of community members and energy resources. The variables used are described in Section 9.1. Electricity consumption data for individual members was used in all the scenarios.

9.2.1 Scenarios Considered

In order to describe the members included in the scenarios, a number has been assigned to each community member (Figure 9.2).

Figure 9.2: The location of community members interested in being part of a renewable energy electricity generating scheme

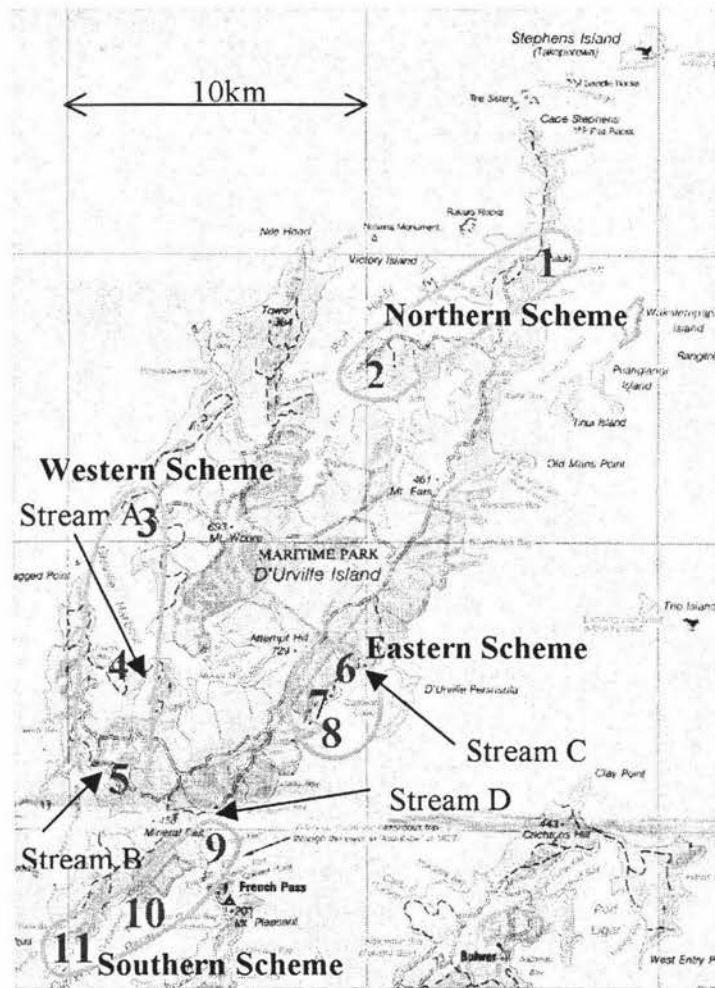

The scenarios considered for D'Urville Island are given in Table 9.4. The peak loads for D'Urville Island are estimates only as no data was available.

Table 9.4: Scenarios considered for the D'Urville Island community

Scenario Number	Included Members	Water Heating Included	Network Length (km)	Peak Load (kW)	Available Energy Resources
1	1	Y	0	12	W,S
2	1	N	0	11	W,S
3	2	Y	0	15	W,S
4	2	N	0	14	W,S
5	3	Y	0	15	W,S
6	3	N	0	14	W,S
7	4	Y	0	12	H,W,S
8	4	N	0	11	H,W,S
9	5	Y	0	5	H,W,S
10	5	N	0	4	H,W,S
11	6	Y	0	16	H,W,S
12	6	N	0	15	H,W,S
13	7	Y	0	6	W,S
14	7	N	0	5	W,S
15	8	Y	0	5	S
16	8	N	0	4	S
17	9	Y	0	6	W,S
18	9	N	0	5	W,S
19	10	Y	0	5	W,S
20	10	N	0	4	W,S
21	11	Y	0	12	W,S
22	11	N	0	11	W,S
23	1,2	Y	8.5	16	W,S
24	1,2	N	8.5	15	W,S
25	3,4,5	Y	14.5	18	H,W,S
26	3,4,5	N	14.5	16	H,W,S
27	4,5	Y	3.75	16	H,W,S
28	4,5	N	3.75	15	H,W,S
29	6,7,8	Y	2.75	22	H,W,S
30	6,7,8	N	2.75	20	H,W,S
31	9,10,11	Y	8.6	17	H,W,S
32	9,10,11	N	8.6	15	H,W,S
33	1 – 11	Y	0	0	H,W,S
34	1 – 11	Y	0	0	W,S

The final two scenarios consider the cost of generating enough electricity for all members, with no storage or transmission. This represents the cost of supplying electricity to the national grid.

9.2.2 Model Inputs

The energy resource inputs have been quantified in Section 7.2.1, and the remainder are detailed in Appendix C.

9.2.3 Results and Recommendations

The financial results are presented in Table 9.5 and the summary sheets in Appendix E.

Table 9.5: Results of D'Urville Island analyses

Scenario Number	Annual Cost of Grid Connection (\$)	Annual Cost of Supplying Renewable Electricity (\$)	c/kWh from Renewable Energy
1	4582	28673	94.5
2	3982	18723	123.4
3	1931	13329	87.8
4	1609	8340	144.1
5	2501	19580	129
6	1823	9340	161.4
7	5519	5983	12.6
8	4761	5983	12.6
9	2405	3205	8.1
10	1924	3509	8.8
11	5945	5681	8.0
12	5145	5377	7.6
13	5006	30816	101.5
14	4685	30816	101.5
15	1624	23232	520.8
16	1510	17263	519.2
17	3661	30066	91
18	2910	18116	109.6
19	1113	9679	156.3
20	1053	5875	94.9
21	2031	13972	92.1
22	1637	8036	138.8
23	6513	61855	203.8
24	5592	48602	160.1
25	10425	48876	55.9
26	8508	48572	55.6
27	7924	16581	34.9
28	6685	16356	34.4
29	12575	13672	19.3
30	11349	13369	18.8
31	6805	28688	60.3
32	5600	28385	59.7
33	36318	16962	5.7
34	36318	12623	7.4

In order to determine the best option for each community member the total annual cost of an individually owned system, a small grid system with one or more other members, and a grid connected system for the entire island were compared (Table 9.6). All the results shown are for schemes that provide for water heating. For the small grid systems a percentage of the total cost was allocated to each member based on the distribution of the members total annual electricity consumption. The grid connected systems of scenarios 33 and 34 assume that all the members contribute to the costs of installing the system, even if the energy resource being utilised is not on their property. The cost for these scenarios was shared between members on the basis of the percentage of the community's total electricity consumption they used. The ratios used to distribute the costs in community scale schemes are given in Table 9.7.

Table 9.6: Annualised costs of options for each community member willing to be part of a renewable energy generating scheme on D'Urville Island

Member No.	Present Grid Connection (\$)	Stand Alone (\$)	Small Network (\$)	Grid Connected Hydro (\$)	Grid Connected Wind/Solar (\$)
1	4582	28673	44051	1953	1454
2	1931	13329	17804	789	588
3	2501	19580	13593	1287	958
4	5519	5983	22959	2174	1618
5	2405	3509	12324	1167	869
6	5945	5377	8078	3751	2791
7	5006	30816	4681	2173	1617
8	1624	23232	1116	518	386
9	3661	30066	19378	142	105
10	1113	9679	1291	2127	1583
11	2031	13972	8019	880	655

Table 9.7: The percentage of the total system cost allocated to each member

Member No.	Scenario Number					
	24 and 25	26 and 27	28 and 29	30 and 31	31 and 32	33 and 34
1	0.71	-	-	-	-	0.12
2	0.29	-	-	-	-	0.05
3	-	0.28	-	-	-	0.08
4	-	0.47	0.37	-	-	0.13
5	-	0.25	0.63	-	-	0.07
6	-	-	-	0.58	-	0.22
7	-	-	-	0.34	-	0.13
8	-	-	-	0.08	-	0.03
9	-	-	-	-	0.58	0.01
10	-	-	-	-	0.34	0.13
11	-	-	-	-	0.08	0.05

These results show that if a property has hydro electric potential the costs of generating electricity in a stand alone scheme are comparable to remaining grid connected, if that remains possible in the future. A stand alone scheme for community members without a hydro resource cost between 6 and 14 times more than their current grid connection.

The four small scale grids illustrated in Figure 9.2 were evaluated and produced the following results⁷.

- Based on the results of scenarios 23 and 24, a northern scheme using wind and solar resources was considerably more expensive than stand alone systems due to the large distance between the two properties involved.
- Based on the results of scenarios 25 – 28, the western scheme was more expensive than existing stand alone schemes for the two members with their own hydro resource. For the third member the cost of a small scale grid was less than a stand alone system using wind and solar resources.
- Based on the results of scenarios 29 and 30, the eastern scheme was cheaper for the properties that have no hydro resource, and was slightly more expensive than a stand alone scheme for the property that did have a hydro resource.

⁷ Refer to Appendix E for details of the equipment required for these schemes and the contribution of each energy resource to the scheme.

- Based on the results of scenarios 31 and 32, the southern scheme produced cheaper electricity than stand alone schemes for all members, but not the existing grid connection.

The cost of electricity production from hydro (5.7 c/kWh) and wind (7.4 c/kWh) on the island compare favourably with the average cost of 27.8c/kWh for a grid connection.

The best solution for all community members based on these cost per kWh results would be for the community to invest in four hydro turbines that supply surplus electricity to the national grid. Cost effective electricity can also be generated from stand alone or small community schemes for some members. However, if the sections of grid that were not utilised were removed from the island those without access to a hydro resource would be left with a very expensive electricity supply.

10 Conclusions and Summary

The concept of community owned distributed power supply using renewable energy sources is one that is gaining acceptance world wide. In many countries the government is aiding this concept through legislation and tax incentives, but in New Zealand these incentives do not exist. However, the issue of electricity supply to rural areas is becoming an issue of importance to the present government.

The optimum means of legal ownership of a community scheme would depend on the size of the community. Three structures have been identified that vary in cost, complexity, and the protection they give their members. An incorporated society would be the best option for most communities, although these are limited to being greater than 15 and less than 50 members. Community schemes involving more than 50 members would be required to register as a company. Communities of less than 25 members may also form a partnership, but this structure provides the least legal protection for its members.

The Resource Management Act will have implications for future renewable energy projects. At one of the case study sites the district plan restricted the development of hydro schemes with very specific rules that applied in all locations throughout the district. If micro hydro systems are to be installed in rural areas of New Zealand without incurring significant resource consent costs, more flexibility needs to be built into local body plans. Some community members expressed interest in developing hydro schemes without resource consent as they saw the plans as too restrictive. Better environmental results would be achieved if guidelines were given that encouraged renewable energy development, rather than discouraged it, and gave incentives for potential developers to consult with councils.

The energy resources of the two sites were monitored, along with electricity consumption at one of the sites. A computer model based on current component costs was developed to enable a rapid assessment of the cost of supplying electricity to a community from renewable resources.

The results obtained for both communities showed that cost effective electricity can be generated if the communities remain grid connected. At Totara Valley the most cost effective grid connected scheme required the development of hydro, wind and solar resources, while on D'Urville Island the most cost effective option was achieved using four hydro turbines.

There are a number of advantages associated with a grid connected scheme. These are:

- reduced cost to the community as no storage or transmission equipment is required;
- improved quality of supply for community residents;
- environmental benefits from avoiding the need for disposal of batteries.

The major disadvantage of a grid connected option would be that the threat of discontinuation of supply after 2013 would not be overcome.

The cost of stand alone community owned schemes were on average 4.5 times higher than supplying electricity with existing grid connections. This is due to the high costs of storage and the community having to take ownership of the network. However, community schemes were more cost effective than stand alone schemes for each member in 60% of the cases. The remaining 40% either had hydro generation available to them, which significantly reduced the costs of a stand alone scheme, or large distances between them and their nearest neighbour which made a community scheme more expensive due to line and distribution costs. If members that had hydroelectric potential could sell their power at the appropriate rate to the rest of the community, all members would be able to benefit from schemes.

Hot water consumes a large amount of electricity in rural homes, farms and businesses. A third of all the electricity consumed by the case study communities was used for heating water. If this load could be partially or fully met by solar hot water heaters or instantaneous gas heating the cost of a renewable energy scheme would be reduced considerably.

Other energy efficiency measures would reduce the cost of renewable energy schemes due to a reduced energy generation and storage requirement. The peak loads

experienced as a result of farming activities such as shearing increase the size and number of inverters required, for a load that may occur only three times during the year. Alternative methods of electricity generation such as using portable generators for seasonal farming loads would need to be considered to reduce the peak loads.

The computer model developed during the study enables assessments to be made for a number of different scenarios, thus identifying the best option. The model could be improved with the addition of a diesel generation option and analysis, however this was not within the scope of the study.

10.1 Recommendations for Further Research

This study is only the start of the process of identifying the optimum electricity generating option for New Zealand's rural communities.

Community owned grid connected renewable energy schemes need to be investigated in detail to determine their true cost. The relationship between a community and its local power supply companies needs to be researched in each case in order to quantify the possible benefits for all parties.

Energy efficiency in rural communities also needs to be encouraged, as storage and transmission equipment required to meet peak seasonal loads makes stand alone systems prohibitively expensive. Efficiency could come from technological improvements as well as the sharing of resources within the community. The benefits of energy efficiency could then be ascertained using the Renewable Communities model.

Demonstration systems need to be developed with funding from outside these communities to allow thorough investigation and monitoring of the options.

The computer model needs to be verified using data from an established case study site.

Bibliography

Australian Bureau of Meteorology Website (1999).

<http://www.bom.gov.au/sat/glossary/shtml#sunshineduration>

Barnes, J. (1997). Proposal for Development and Demonstration of a Protocol for Community Owned and Operated Green Grid Remote Area Power Systems. *James Barnes and Associates Limited*

Baywind Energy Co-operative (1995). Share offer and fact sheet.

Baywind News (1996). Issue One, Winter 1996/97.

Bloemink, S. (1998). *pers. comm.* – Eastland Network Ltd., Gisborne, New Zealand

Bowley, J. (1996). Micro-hydro Power Facility. *Massey University*

Boxer, S. (1995). ETSU Seminar on Third Party Finance – Harlock Hill Case Study (II), *Lancashire, UK*

Brain, M. (2000). How Stuff Works - How Solar Cells Work. *<http://www.howstuffworks.com/solar-cell.htm>*

Brower, M. (1992). Cool Energy: Renewable Solutions to Environmental Problems. *MIT Press*

Campbell Scientific (1998). Calculating Sunshine hours from pyranometer / solarimeter data. Technical Note 18. *<http://www.campbellsci.com/europe/support/technts/technt18>*

Carruthers, D.L., (2000). *pers. comm.* – Partner – *Carruthers and Wetherall, Greymouth*

Charitable Trusts Act (1957). *New Zealand Government, Wellington*

Chignell, A. (1997). *Company Basics – Running a company in New Zealand. Toha Kape Limited*

Companies Office. A guide to the Incorporated Societies Act 1908. *Ministry of Commerce*

Companies Office Internet Site. <http://www.companies.govt.nz>

Companies Office. A guide to Incorporating a Charitable Trust under the Charitable Trusts Act 1957. *Ministry of Commerce*

Corkish R. (1997). Can Solar Cells Ever Recapture the Energy Invested in their Manufacture. *Australia and New Zealand Solar Energy Society vol. 18, No. 2, pp.16-17*

Culy, J.G., Read, E.G. and Wright, B.D. (1995). The evolution of New Zealand's electricity supply structure. *Working Paper 94/33, New Zealand Institute of Economic Research*

Dakers, A.J. and Martin, G. (1982). Development of a simple Crossflow turbine for rural use. *Proceedings of the Ministry of Agriculture and Fisheries Engineering Conference, August 1982, 35 – 41.*

Dale, D.A. (1968). Private Companies in New Zealand. *Street and Maxwell (N.Z.) Ltd.*

Dunn, P.D. (1986). Renewable energies: sources, conversion and application. *Peter Peregrinus Ltd.*

Edwards, P.J. (1986). Small scale wind power for New Zealand, Australia and the South Pacific (NZERDC Report No. 136), *University of Auckland*

Electricity Act 1992. *New Zealand Government, Wellington*

- Electricity Industry Reform Act 1998. *New Zealand Government, Wellington*
- Elliot, D. (1997). *Energy, society and environment. Routledge*
- Energy Efficiency and Conservation Authority (EECA) and Centre for Advanced Engineering (CAE), (1996). *New And Emerging Renewable Energy Opportunities in New Zealand. Christchurch.*
- Energy Efficiency and Conservation Authority (1996). *Planning Guidelines for Renewable Energy Developments. EECA, Wellington.*
- Energy Efficiency and Conservation Authority (1997). *Energy use in New Zealand households: Year 1 update report on the Household Energy End-Use Project (HEEP). EECA, Wellington.*
- Energy Foundation of New Zealand (Inc), (1996). *New Zealand's Energy Future: A Look Ahead*
- Food and Agriculture Organisation of the United Nations (FAO), (1990). *A new approach to energy planning for sustainable rural development. FAO*
- Forsyth, T.A. (1998). *A Brief Outline of the Law Relating to Trusts, Wills, Executors and Administrators. Dunmore Press*
- Fraunhofer Institute for Solar Energy Systems Website (2000). <http://www.ise.fhg.de/>
- Giddens, A. (2000). *pers. comm.* – Scanpower Network Manager.
- Golob R. and Brus, E (1993). *The Almanac Of Renewable Energy. Henry Holt and Company, New York*

- Gopinathan, K.K. (1988). A general formula for computing the coefficients of the correlation connecting global solar radiation to sunshine duration. *Solar Energy Vol. 41, No. 6, pp. 499- 502*
- Gray, A.T. (1996). The Earth Garden Book of Alternative Energy. *University of Otago Press*
- Gunn, C. (1996). Optimal energy company behaviour in New Zealand's deregulated electricity market: Issues and comments. *Working Papers in Economics, No. 156, Auckland University*
- Parliamentary Commissioner for the Environment, (2000). Getting More From Less – a review of progress on energy efficiency and renewable energy initiatives in New Zealand. *Wellington*
- Hohmeyer, O. (1992). Renewables and the full costs of energy. *Energy Policy, April 1992, 365 - 375*
- Horizons.mw (1999). How to Apply for a Resource Consent
- Horizons.mw (1999). How to Apply for a Water Permit
- Horizons.mw (1999). How to Apply to Disturb the Bed of any Lake or River
- Hothersall, R.J. (1984). Micro-hydro development for PNG. *Canterbury University*
- Incorporated Societies Act 1908. *New Zealand Government, Wellington*
- Issacs, N. (1997). Energy Use in New Zealand Households: report on the Household Energy End use Project (HEEP) *Energy Efficiency and Conservation Authority (New Zealand)*
- Lawrence, M. (1998). Legal Studies – A first book on New Zealand Law. *The Dunmore Press Limited.*

- Liu, B.Y.H. and Jordan, R.C. (1960). The interrelationship and characteristic distribution of direct, diffuse and total solar radiation. *Solar Energy*, 4, 1-19
- McNiell, J. (2000). *pers. comm.* – Horizons.mw Manager of Policy and Projects
- Ministry of Commerce (2000). Energy Data File January 2000 Online – Energy Overview. <http://www.moc.govt.nz/ran/emisg/emsu/edfolin/edfjan2000/energyoverv.html>
- Ministry of Energy, (1986). Remote Area Power Systems. Information For On-site Energy Services
- Ministry of Agriculture and Fisheries (1992). Policy Technical Paper 93/7
- Ministry of Agriculture and Fisheries (1998). Rural Bulletin, July 1998
- Mitchell, R. (1995). Community involvement in renewable energy projects: a guide for community groups. *ETSU*
- Mulholland, R.D. (1999). Introduction to the New Zealand Legal System – Ninth Edition. *Butterworths, Wellington*
- Mulholland, R.D. (1983). Business Law Today. *The Dunmore Press*
- New Energy and Industrial Technology Development Organisation (NEDO), (1999). Solar Cell Manufacturing Technology. <http://www.nedo.go.jp/3colore/shinene/taiyo-1.html>
- National Institute of Water and Atmospheric Research (October 1999). *pers. comm.* – Climate Business Development Manager
- Northern Arizona Wind and Sun (NAWS) Website, (1999). Batteries for Deep Cycle Applications. http://www.windsun.com/Batteries/Battery_types.htm

- Paris, S. (1996). *Two per mile : a history of the Rural Electrical Reticulation Council. Morris Communications Group Ltd*
- Partain, L.D. (1995). *Solar Cells and Their Applications. Wiley and Sons Inc, New York*
- Patel, M.R. (1999). *Wind and Solar Power Systems. CRC Press*
- Paul, T.F. (1986). *The law and administration of incorporated societies. Butterworths, Wellington*
- Pimentel, D. et. al. (1994). *Renewable Energy - Economic and Environmental Issues. BioScience - Vol. 44, No. 8, September 1994*
- Resource Management Act (1991). *New Zealand Government, Wellington*
- RSVP Library. <http://www.rsvp.nrel.gov/rsvp/tour/Library/library.html>
- Sagrillo, M. (1998). *Apples and Oranges. Home Power #65, June/July 1998, pg. 18 – 32*
- Schoenrich, L., Nadeau E.G. (1997). *Locally-Owned Wind Energy Feasibility Project: Final Report. http://www.me3.org/projects/seed/localfease.html*
- Soma Wind Turbines. <http://www.solarsales.oz.nf/soma.html>
- Solarex Website (1999). <http://www.solarex.com>
- Stickler, G., (Unknown Date) (NASA). *Educational Brief - Subject: Solar Radiation and the Earth System. Topic: Relating Solar Radiation Physics to Earth & Space Science Concept. http://education.gsfc.nasa.gov/experimental/all98inv/Project.Site/Pages/science-briefs/ed-stickler/ed-irradiance.html*

- Suehrcke, H. and McComick, P.G. (1989). The distribution of average instantaneous terrestrial solar radiation over the day. *Solar Energy, Vol. 42, No. 4, pp 303 - 309*
- Sustainable Energy Forum, (1998). Energy for our country : opportunities for the 21st century : energy policies and the rural sector : proceedings, 5th Annual Conference of the Sustainable Energy Forum, Palmerston North, New Zealand, 3rd-6th February 1998. (Editors, N.K. Mander and R.E.H. Sims) *Wellington*
- Sustainable Energy Forum, (2000). Energy Watch – The Newsletter of the Sustainable Energy Forum. *Issue 13, April 2000, Wellington*
- Tamar Designs, (Unknown date). Electricity from water. *Brochure TL85*
- Trace Technologies Limited website (1999). <http://www.traceengineering.com>
- Tranaes, F. (1997). Danish Wind Energy Cooperatives, Part 1. <http://www.windpower.dk/articles/coop.html>
- Webb, P.R.H. and Webb, A. (1987). Principles of Law and Partnership. *Butterworths, Wellington*
- Weiss, S.D. (1992). Renewable energy System Design: A guide to the application of photovoltaic, wind, and micro-hydro power. *Massey University*
- Vosburgh, P.N. (1983). Commercial Applications of Wind Power. *Canada: van Nostrand.*
- Wardle, P. (1998). *pers. comm.* – Akitio holiday home owner
- Windpower.dk (Danish Wind Turbine Manufacturers Association) web site (1999). <http://www.windpower.dk>

- Wharton, T.L. (1995). Least-cost Domestic Heat Energy Investments For Great Barrier Island Under Restrictions On The Harvesting Of Native Fuelwood Species. *Massey University*
- Yeaman, E.M. (1998). Application of stand-alone power systems models in New Zealand. *Massey University*

APPENDIX A

Mathematical Basis of the Renewable Communities Computer Model

Appendix A

The equations and reasoning used in the model as described in Chapter 8 are provided.

A.1 Electricity Demand Section

The annual cost of electricity supplied by the national grid is based on the present day tariffs of the local lines and energy companies. These tariffs are quantified in Sections C.1.1. and C.2.2.

For an individual analysis, the amount of energy consumed on each connection is multiplied by the energy and supply tariffs for the connection type. Tariffs that are charged on a daily or monthly basis are also calculated over a 12 month period for each connection, and added to the energy and supply tariffs.

In the community analysis similar calculations are carried out using the communities combined monthly consumption for each connection type. Tariffs that are charged on a daily or monthly basis are calculated over a 12 month period for a user specified number of domestic and commercial connections.

A.2 Hydro Resource and Technology Section

The calculation for the expected power output of the turbine is based on the penstock internal diameter required to achieve the specified head loss.

A.2.1 Penstock Diameter

The penstock internal diameter is calculated using Equation A.1. As the diameter appears three times in the equation and velocity twice, an Excel Solver function is used to vary the diameter until the specified head loss for a given site is achieved.

$$H_f = \frac{0.25}{\left[\log \left(\frac{k}{3.7d} + \frac{5.74}{(vd/\mu)^{0.9}} \right) \right]^2} \cdot \frac{Lv^2}{2gd} \quad \text{Equation A.1}$$

where H_f = head loss due to friction (m)

k = roughness coefficient

d = penstock internal diameter (m)

v = flow velocity (ms^{-1})

L = penstock length

g = gravity (9.81 ms^{-2})

μ = fluid viscosity ($1.01 \times 10^{-6} \text{ m}^2/\text{s}$ for water)

This equation is based on Darcy's formula for head lost to friction in pipes (Equation A.2) and the Colebrook – White equation (Equation A.3) that defines the friction factor (f) used in Darcy's formula.

$$H_f = \frac{4fL}{d} \cdot \frac{v^2}{2g} \quad \text{Equation A.2}$$

where f = friction factor

$$\frac{1}{f^2} = -4 \log_{10} \left[\frac{6.9}{\text{Re}} + \left(\frac{k}{3.71d} \right)^{1.11} \right] \quad \text{Equation A.3}$$

where Re = Reynolds Number = vd/μ

The internal pipe surface roughness coefficients (k) used in the model are given in Table A.1. For new pipe the values for pipes less than five years old should be used. If old pipe is being used the normal values should be used.

Table A.1: Pipe roughness coefficients used in the model

Pipe Material	Good (<5 years)	Normal (5 – 15 yrs)
Concrete	0.00006	0.00015
PVC, HDPE, MDPE, Glass Fibre	0.000003	0.00001
Mild Steel – Uncoated	0.00001	0.0001
Mild Steel – Galvanised	0.00006	0.00015
Cast Iron	0.00015	0.003

A.2.2 Power Output

The power output of the turbine is calculated using Equation A.4 below.

$$P = eQH \quad \text{Equation A.4}$$

where e = the efficiency of the turbine. The efficiency used in the model is 60%, which is the typical value used by Tamar Turbines in their turbine specifications (Tamar, 1999). This value gives the ratio of the expected shaft output to the theoretical output of a 100% efficient turbine.

Q = available flowrate (l/s)

H = available head (m)

A.3 Wind Resource and Technology Section

This analysis can be carried out on a monthly or annual basis, depending on data availability. The calculations for the two options are identical.

A.3.1 Wind Speed at Turbine Hub Height

The mean annual or monthly wind speed at the turbine hub height is calculated for each of the turbines listed in the turbine database (Equation A.5).

$$V_1 = V_0(h_1/h_0)^\alpha$$

Equation A.5

- where V_1 = mean annual or monthly wind speed at turbine hub height
 V_0 = mean annual or monthly wind speed at anemometer height
 h_1 = turbine hub height
 h_0 = anemometer height
 α = surface roughness coefficient.

The surface roughness coefficients used in the model are given in Table 8.2.

A.3.2 Wind Speed Distribution

Once the mean monthly or annual windspeed at the turbine hub height has been determined, the wind speed distribution is calculated, based on a Weibull function with the shape parameter (k) being provided by the model user, and the scale parameter (C) calculated using Equation A.6.

$$C = v / 0.09$$

Equation A.6

where v = the average windspeed at the turbine hub height.

The Weibull distribution is defined by Equation A.7.

$$f(v_x) = \left(\frac{k}{C}\right) \left(\frac{v}{C^{k-1}}\right) \exp\left[-(v/C)^k\right]$$

Equation A.7

- where $f(v_x)$ = probability of wind at speed v_x
 v = average wind speed
 k = Weibull shape parameter
 C = Weibull scale parameter

A.3.3 Turbine Output

For each turbine in the database, the turbine output is calculated by multiplying the wind speed distribution by the turbine power curve for wind speed from 1 to 30 ms⁻¹. The power output produced at each wind speed is summed, giving the total annual or monthly power output expected from the turbine.

A.4 Solar Resource and Technology Section

This section optimises the solar array size required to meet a given load using the assumptions described below.

A.4.1 Mathematical Basis of the Solar Model.

Solar radiation is received on the Earth's surface from three sources¹. Beam radiation (G_b) is the radiation that is received directly from the sun without being scattered by the Earth's atmosphere. Diffuse radiation (G_d) occurs as a result of beam radiation being scattered by the Earth's atmosphere. Ground radiation (G_g) is reflected from the ground back into the atmosphere.

The sum of these sources of radiation on a horizontal surface is known as global radiation and is usually given in Watts/m² (G_T) (Equations A.8).

$$G_T = G_b + G_d + G_g \qquad \text{Equation A.8}$$

As the solar resource can be quantified using MJ/m² or sunshine hours, the model gives the user the ability to use either of these measurements.

A.4.1.1 Converting Sunshine Hours to Global Radiation

Sunshine hours are defined as “the sum of all time periods during the day when direct solar irradiance equals or exceeds 120 W/m²” (Australian Bureau of Meteorology, 1999). In

¹ Throughout the model, G refers to radiation in general, H refers to radiation on a daily basis and I refers to radiation on an hourly basis.

order to determine the output of a solar panel, sunshine hours need to be converted to global solar radiation for a specific site.

The process used to convert sunshine hours (S) to global radiation (G_T) is taken from Gopinathan (1988). The equation that forms the basis for the conversion is:

$$H = H_o \left[a + b \left(\frac{S}{S_o} \right) \right] \quad \text{Equation A.9}$$

where H = monthly mean daily global radiation on a horizontal surface

H_o = monthly mean daily radiation on a horizontal surface assuming there is no atmosphere

S = monthly average sunshine hours

S_o = length of the solar day for the middle day of the month

H_o is calculated using Equation A.10.

$$H_o = \frac{86400 G_{sc}}{\pi} \left[1 + 0.033 \cos \left(\frac{360n}{365} \right) \right] \left[\cos \phi \cdot \cos \delta_s \cdot \sin \omega_s + \frac{2\pi \omega_s}{360} \cdot \sin \phi \cdot \sin \delta \right] \quad \text{Equation A.10}$$

where G_{sc} = the solar constant = 1353 W/m² (Duffie and Beckman, 1991)

n = Julian day of the year

ϕ = site latitude

δ = declination

ω_s = Sunset hour angle in degrees, given by:

$$\omega_s = \cos^{-1}(-\tan \phi \cdot \tan \delta) \quad \text{Equation A.11}$$

The length of the solar day (S_o), or maximum possible sunshine hours is given by:

$$S_o = \left(\frac{2}{15} \right) \cos^{-1}(-\tan \phi \tan \delta) \quad \text{Equation A.12}$$

where ϕ is the site latitude

δ is the declination angle (Figure A.1) and is given by:

$$\delta = 23.45 \sin \left[\frac{360(284 + n)}{365} \right] \quad \text{Equation A.13}$$

where n is the Julian day.

Figure A.1: Declination angle

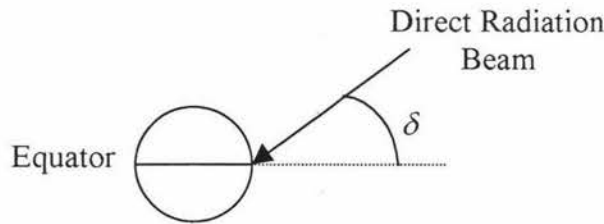

Gopinathan (1988) defined the constants a and b as:

$$a = -0.309 + 0.539 \cos \phi - 0.0693h + 0.290 \left(\frac{S}{S_o} \right) \quad \text{Equation A.14}$$

$$b = 1.527 - 1.027 \cos \phi + 0.926h - 0.359 \left(\frac{S}{S_o} \right) \quad \text{Equation A.15}$$

where ϕ = site latitude (Figure A.2)

h = site altitude above sea level in kilometres.

Figure A.2: Site latitude

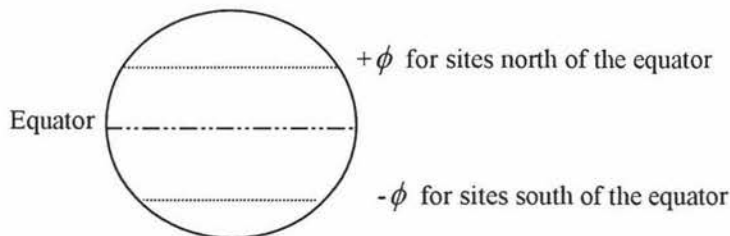

A.4.1.2 Calculating Diffuse and Direct Radiation

Once the global radiation has been determined, the ratio between direct and diffuse radiation (K_d) needs to be calculated. The model is based on that presented by Erbs, Klein and Duffie (1991) giving three equations (Equation A.16) for determining the diffuse/global ratio. These equations are dependant on the clearness index, K , which is defined as the ratio of daily average global radiation, H , to daily average extraterrestrial radiation, H_o .

$$\begin{array}{ll}
 K_d = 1.0 - 0.09K & \text{for } K \leq 0.22 \\
 K_d = 0.9511 - 0.1604K + 4.388K^2 & \text{for } 0.22 < K \leq 0.80 \\
 \quad - 16.638K^3 + 12.336K^4 & \\
 K_d = 0.165 & \text{for } K > 0.80
 \end{array}
 \left. \vphantom{\begin{array}{l} \\ \\ \\ \end{array}} \right\} \text{Equation A.16}$$

where $K = \text{Clearness Index} = \frac{H}{H_o}$

This analysis is carried out on a monthly basis, giving average daily diffuse and direct components for each month.

A.4.1.3 Daily Analysis

In order to calculate the energy available over an entire day, the ratio of hourly global radiation (I) to daily global radiation (H) needs to be established. This ratio is given by Suehrcke and McCormick (1989) as:

$$\frac{I}{H} = (a + B \cdot \cos \omega) \frac{I_o}{H_o} \quad \text{Equation A.17}$$

where $\frac{I_o}{H_o} = \frac{\pi}{24} \frac{\cos \omega - \cos \omega_s}{\sin \omega_s - \omega_s \cdot \cos \omega_s}$ Equation A.18

$$a = 0.409 + 0.5016 \sin \left(\omega_s - \frac{\pi}{3} \right) \quad \text{Equation A.19}$$

$$b = 0.6609 - 0.4767 \sin\left(\omega_s - \frac{\pi}{3}\right) \quad \text{Equation A.20}$$

$$\begin{aligned} \omega &= \text{hour angle} \\ &= 15 \cdot (\text{hour of the day} - 12) \end{aligned}$$

Using this ratio, the global solar radiation for each hour of the middle day of the month (I) is calculated.

The hourly global solar radiation is then split into beam and diffuse components. The diffuse component is found using Equation A.21:

$$I_d = \frac{I_o}{H_o} \cdot H_d \quad \text{Equation A.21}$$

where $H_d = k_d \cdot H$

The beam component of the hourly global radiation is found using Equation A.22:

$$I_b = I - I_d \quad \text{Equation A.22}$$

A.4.1.4 Determining Radiation on a Sloped Surface

In order to optimise the output of a solar panel it is best to tilt the panel to an angle approximately equal to the latitude of the site. This means that the solar radiation received by a sloped surface needs to be calculated. The method used for these calculations is based on that presented by Duffie and Beckman (1991).

As with radiation on a horizontal surface, the total radiation on a tilted surface (I_t) is the sum of beam (I_{bt}), diffuse (I_{dt}) and ground reflected (I_{gt}) radiation.

$$I_t = I_{bt} + I_{dt} + I_{gt} \quad \text{Equation A.23}$$

The beam component (I_{bt}) is found using R_b , the ratio of beam radiation on a tilted surface to beam radiation on a horizontal surface. R_b is defined as:

$$R_b = \frac{\cos \theta}{\cos \theta_z} \quad \text{Equation A.24}$$

where θ = the angle of incidence of direct radiation to the normal of the tilted plane, and
 θ_z = zenith angle (the angle of the sun to directly overhead)

Equations A.25 and A.26 below define $\cos \theta$ and $\cos \theta_z$.

$$\cos \theta = \sin \delta \cdot \sin \phi \cdot \cos \beta - \sin \delta \cdot \cos \phi \cdot \sin \beta \cdot \cos \gamma + \cos \delta \cdot \cos \phi \cdot \cos \beta \cdot \cos \omega + \cos \delta \cdot \sin \phi \cdot \sin \beta \cdot \cos \gamma \cdot \cos \omega + \cos \delta \cdot \sin \beta \cdot \sin \gamma \cdot \sin \omega \quad \text{Equation A.25}$$

$$\cos \theta_z = \cos \phi \cdot \cos \delta \cdot \cos \omega + \sin \phi \cdot \sin \delta \quad \text{Equation A.26}$$

where δ = declination

ϕ = latitude of the site, (south of the equator is negative)

β = tilt of the surface to the horizontal

γ = surface azimuth angle (orientation of the panel surface with respect to true north) Note: South = 0, East is negative and West is positive

ω = hour angle

Hourly beam radiation on a tilted surface is therefore:

$$I_{bt} = I_b \cdot R_b \quad \text{Equation A.27}$$

The diffuse radiation on a tilted surface is found using Equation A.28 (Lui and Jordan 1960).

$$I_{dt} = I_d \frac{(1 + \cos \beta)}{2} \quad \text{Equation A.28}$$

where β = angle of tilt of the panel surface to the horizontal (Figure A.3).

Figure A.3: Panel Tilt

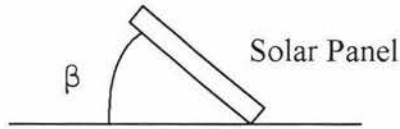

The ground reflected component of the total radiation is calculated using Equation A.29 (Duffie and Beckman, 1991).

$$I_{gt} = I \rho_g \frac{(1 - \cos \beta)}{2} \quad \text{Equation A.29}$$

where ρ_g = ground albedo (or reflectivity)

β = angle of tilt of the panel surface to the horizontal

The model enables the user to select a value for ground albedo from a drop down list. The values given are averages of the ranges given by Yeaman (1998). Table 8.3 gives the values that are used in the model.

A.4.1.5 Optimising the Panel Array

The model optimises two parameters in order to minimise the costs of the solar array.

These parameters are:

- Panel tilt
- Panel Surface Area

A.4.1.6 Panel Tilt

The model uses an Excel Solver function to optimise the panel tilt angle to produce maximum power for the site. The result of the Solver calculation is limited to being greater than 0° and less than 90° to ensure a valid result.

A.4.1.7 Panel Surface Area

The model then optimises the required array area so that the array produces the required power, as calculated in the Electricity Demand section of the model (Section 8.1).

A.5 Analysis Section

In each Resource and Technology section of the model a financial cost benefit analysis has been carried out for each item in the database to determine the most cost effective components. The Analysis section carries out a financial cost benefit analysis for the complete systems described below.

A.5.1 Net Present Value (NPV)

The NPV allows valid comparisons to be made between different system configurations by discounting all future costs and benefits to present day values and then summing these costs. The equation used to calculate the NPV is:

$$NPV = \sum_{n=1}^m \frac{(Cost\ in\ year\ n)}{(1+i)^n} \quad \text{Equation A.30}$$

where n = the age of the system (years)

m = expected system life

i = discount rate = interest rate – inflation rate

The interest rate is the assumed long-term market interest rate of 10%. The inflation rate is only taken into consideration if the benefits of the project are subject to a different inflation rate to the costs, which is not the case in this study. The discount rate was therefore assumed to be 10%.

A.5.2 Annualised Cost

Once the NPV has been determined the annualised cost for the project can be calculated. This is the average annual cost of owning and operating the system in today's dollars. The annualised cost is calculated from the NPV using Equation A.31.

$$Annualised\ Cost = \frac{NPV(i(1+i)^n)}{((1+i) - 1)} \quad \text{Equation A.31}$$

A.5.3 Unit Cost of Energy

In order to make comparisons between the cost effectiveness of different options, the cost per unit of energy (kWh) produced is calculated. This is achieved by dividing the annualised cost of production (\$/year) by the net annual power output (kWh/year) (Equation A.32).

$$\textit{Unit Cost of Energy} = \frac{\textit{Annualised cost of production}}{\textit{Net power produced}} \quad \textit{Equation A.32}$$

APPENDIX B

Household Questionnaire

Information Sheet

THE FEASIBILITY OF COMMUNITY OWNED AND OPERATED RENEWABLE ENERGY SCHEMES.

Thank you for taking the time to answer this questionnaire. Your assistance is greatly appreciated.

What is this study about? The objective of this study is to investigate the feasibility of a community owned and operated renewable energy scheme in the community of Totara Rd. This study is being carried out in response to recent changes in legislation that will (a) make rural power supplies considerably more expensive over the coming years (Electricity Industry Reform Act, 1998), and (b) allow electricity lines companies to disconnect any unprofitable customers after April 1st, 2013 (Electricity Act 1992). Although some of these changes may seem a long way off, it is vital that remote rural areas such as yours consider your future electrical security.

By being involved in this research project and answering the attached questionnaire you will be able to make the first steps towards preparing for your future at no cost to yourself. I am seeking to fully investigate your renewable energy options and aim to find the best possible solution for you and your community.

Your community has been chosen as one of three case study sites to help me identify the important issues relating to renewable energy schemes of this type. You have received this questionnaire because you own land within the community.

How do you return the questionnaire? I will visit you in person in mid to late January to collect the questionnaire. You do not need to do anything other than complete it and keep it in a safe place until then.

Confidentiality: The nature of this study requires that we know who is responding so you will be asked for your name and contact details. The information that you provide will be used solely for the purposes of this study. I would also like to assure you that answering this questionnaire will not commit you to being involved in a renewable energy scheme in the future.

Who is conducting this research? This study is a joint project between Powerflow Ltd. (a well established New Zealand renewable energy company), and Massey University. It is being carried out as part of a Masters Degree with the Institute of Natural Resources. If you have any questions regarding this study please call me at (04) 384-1988 or (06) 350-4357 during work hours.

Sincerely

Glenn Irving
Powerflow Ltd.

THIS QUESTIONNAIRE SHOULD BE COMPLETED
BY THE HEAD OF THE HOUSEHOLD

Section A - Personal Details

A1. Are you willing to be contacted in the future if any of the answers you give need to be clarified? Please tick.

1 Yes - **Please fill out your details in Question A2**

2 No - **Please go to Question A3**

A2. Name: _____

Address: _____

Contact Phone No: _____ Fax No: _____

E-mail Address: _____

A3. Main source(s) of income for your household / property within the community - please tick the most appropriate box(es):

- | | |
|---|---|
| 1 <input type="checkbox"/> Sheep and beef farm | 6 <input type="checkbox"/> Accommodation / holiday home |
| 2 <input type="checkbox"/> Dairy farm | 7 <input type="checkbox"/> Tourism activities |
| 3 <input type="checkbox"/> Fishing | 8 <input type="checkbox"/> Forestry |
| 4 <input type="checkbox"/> Retail | 9 <input type="checkbox"/> Retired |
| 5 <input type="checkbox"/> Benefit (Government/ ACC etc.) | 10 <input type="checkbox"/> Other _____ |

A4. Which of the following categories best describes the total yearly income of everyone in your household, from all sources, before tax? Please tick.

- | | |
|--|---|
| 1 <input type="checkbox"/> \$0 - \$9999 | 5 <input type="checkbox"/> \$75,000 - \$99,999 |
| 2 <input type="checkbox"/> \$10,000 - \$24,999 | 6 <input type="checkbox"/> \$100,000 - \$124,999 |
| 3 <input type="checkbox"/> \$25,000 - \$49,999 | 7 <input type="checkbox"/> \$125,000 - \$149,999 |
| 4 <input type="checkbox"/> \$50,000 - \$74,999 | 8 <input type="checkbox"/> Greater than \$150,000 |

Section B - Your Property:

B1. Does your property contain the following features? Please tick.

- 1 Streams that flow all year
- 2 Exposed ridge tops that you would identify as being particularly windy
- 3 Property contains neither of these features

B2. If your property does contain the features above, what distances are they from the main residence on the property? Space is given for the nearest 5 streams or ridges.

	Distance in meters to main dwelling (approx.)				
	1	2	3	4	5
Streams					
Exposed Ridges					

B10. What is your role on the land that you are using (e.g. farm manager, leasing)

B11. Please give the contact details of the landowners below so that we can inform them about this research project. (Note: you may need to check with the landowners to obtain their permission)

Name: _____

Address: _____

Contact Phone No: _____ Fax: _____

E-mail: _____

B12. On the back page of this questionnaire is a map of your community. Please indicate as many of the following features as possible on that map:

- The approximate boundary of your property
- The location of the main residence on your property
- The location of the main property of your closest neighbour
- Any streams within your property that flow all year
- Any exposed, windy ridges on your property that could be used for the installation of wind turbines

Section C - The Supply and Usage of Electricity

C1. Please indicate on the timeline below how important a reliable source of power is at different times of the day. (e.g. you might think that having power at 6.00pm for cooking is very important, but it would be less important to have power at 2.00am when people are asleep.) Tick a box for each time bracket.

IMPORTANCE	High	7																						
		6																						
		5																						
		4																						
		3																						
		2																						
	Low	1																						
			0-2	2-4	4-6	6-8	8-10	10-12	12-2	2-4	4-6	6-8	8-10	10-12										
			am						pm															

C2. How many buildings do you have on your property that are supplied with electricity from the National Grid? (e.g. houses, sheds, garages, pump houses etc.)

No. of buildings: _____

C3. How many separate electricity connections do you pay for? (e.g. one for the house, one for the farm shed, one for the shearing shed, one for the pump etc.)

No. of connections: _____

C4. The following information is required for each of the connections you identified above - please use the back of this page if more space is required:

- buildings the connection supplies (e.g. house, shearers quarters, milking shed)
- months of the year that power is actually used in the building (e.g. Jan - Jun)
- monthly network service charge for the connection (if known) - this includes all costs other than the purchasing of electricity units (kWh's). Your power bill will contain this information.

Connection Number	Buildings the connection supplies	Months of the year that power is used in the buildings	Monthly network service charge - if known
<i>Connection 1:</i>	A.		
	B.		
	C.		
	D.		
<i>Connection 2:</i>	A.		
	B.		
	C.		
	D.		
<i>Connection 3:</i>	A.		
	B.		
	C.		
	D.		
<i>Connection 4:</i>	A.		
	B.		
	C.		
	D.		

C5. What energy sources (e.g. electricity, wood, gas, etc.) do you currently use for:

Oven cooking _____ Space heating _____
 Stove top cooking _____ Refrigerator _____
 Water heating _____ Freezer _____

C6. Are you currently connected to the national electricity grid?

- 1 [] Yes - **Please go to Question C7**
 2 [] No - **Please go to Question C10**

C7. What equipment do you use to produce your electricity at present (eg diesel generator, solar panels, wind turbine etc.)? _____

- C8. Would you be interested in joining onto a community scale generation system if one was installed in your community? Please give the reasons for your answer.
- 1 [] Yes. Reason: _____

- 2 [] No. Reason: _____

- C9. What are your reasons for not being connected to the grid at present? _____

Present Energy Usage:

C10: This question is required to calculate the power that your household uses. The following columns are given:

- Number Used - how many of the appliances you have on your property (e.g. two televisions)
- Power Rating - the number of watts required to run the appliance. This is usually given on the appliance (e.g. 1000W). If you cannot find the value for the appliance please leave the power rating column empty.
- Average hours used per day - the approximate number of hours the appliance is used during a day (e.g. each television might be watched for an hour each night so you would record that they are used an average of two hours per day). Please record times less than an hour in minutes
- Days used per year - the number of days the appliance is used per year. (e.g. the vacuum cleaner may be used 52 days of the year.)

Appliance	No. Used	Power Rating (watts)	Average hours used per day	Days use per year
Kitchen				
Coffee Machine				
Jug				
Toaster				
Can Opener				
Electric Frypan				
Microwave Oven				
Kitchen Blender				
Toasted Sandwich Maker				
Bread Maker				
Electric Knife				
Stove				
Freezer				
Refrigerator				
Crock Pot				
Extractor Fan				

Appliance	No. Used	Power Rating (watts)	Average hours used per day	Days use per year
Living Area				
Television				
Stereo				
Video Machine				
Computer Screen				
Computer				
Cordless Phone				
Printer				
Fan				
Bedroom				
Electric Clock				
Electric Blanket				
Laundry and Cleaning				
Vacuum Cleaner				
Washing Machine				
Clothes Drier				
Iron				
Sewing Machine				
Dust Buster				
Lighting	Please indicate the number of each bulbs at a given wattage. Include all the lights used throughout your house.			
Standard		40 60 75 100 150 Other		
Energy Efficient		13 15 20 Other		
Fluorescent				
Bathroom				
Water Cylinder				
Hair Drier				
Heated Towel Rails				
Heater				
Extractor Fan				
Electric Razor				

Appliance	No. Used	Power Rating (watts)	Average hours used per day	Days use per year
Workshop	Please fill out the details of specific items in the following section. Use the back of this page if you need more space.			
Power tools - e.g. <i>Electric Sander</i>	<i>1</i>	<i>1500</i>	<i>3</i>	<i>10</i>
1				
2				
3				
4				
5				
6				
7				
Welding Equipment				
Lighting				
Flood Lights				
Electric Fences				
Other (please specify)				

Seasonal power requirements:

C11. Due to the nature of your work and lifestyle there could be regular times when you will require more electricity than usual. These requirements could be due to shearing, milking, extended use of workshop tools, or refrigeration, for example. It is important for me to know as much as possible about these activities as they are often the hardest to cater for in a renewable energy system. Please think through what seasonal requirements you have and give details under the headings below. If more space is required please use the back of this page.

Seasonal Activity	Months when activity occurs	Equipment and its power rating (Watts)	Daily Usage (hrs/day)	days/year that loading occurs
<i>e.g. Water pumping</i>	<i>Oct - Feb</i>	<i>Pump (2000W)</i>	<i>5 hrs</i>	<i>150</i>

Section D - Satisfaction with your present power supply

This section is intended to gauge your feelings about the power supply you receive at present and see how that supply could be improved by using renewable energy resources. The following questions are about your satisfaction with various aspects of your power supply. Please tick the number that best suits your satisfaction level.

	Unsatisfied					Satisfied	
How satisfied are you with the quality of the power supply you receive with regards to:	1	2	3	4	5	6	7
D1. <i>power cuts</i>							
D2. <i>the emergency support you receive</i>							
D3. <i>the rates you pay for your electricity</i>							
D4. <i>variations in supply quality that cause problems with appliances (e.g. voltage spikes)</i>							

- D5. Have you kept records of your power bills over the last few years? Please tick the statement that best describes your situation.
- 1 Have kept a full record of statements for the last year or more
 - 2 Have kept a written record for the last year or more
 - 3 Do not keep any records - **Please go to Question E1**
- D6. Would you be happy for your records to be used as part of this study?
- 1 Yes
 - 2 No

If you answered “yes” to this question, **please insert the records for the last two years in the envelope provided**. They will be copied and returned to you as soon as possible.

Section E - Community

This part of the questionnaire is intended to give me an understanding of your perception of the strength of your community. Honest answering of these questions is important - your responses will not be made known to anyone.

- E1. How many years have you owned land /lived within your community? ___ years.
- E2. Please tick the statement below that best describes your view of the community.
- 1 one that works together whenever possible
 - 2 one that works together only when we have to
 - 3 one that never works together
- E3. Please tick the statement that you agree with most from the list below.
- 1 I trust all the members of my community on all issues
 - 2 I do not trust any members of my community
 - 3 I trust some members of my community, but have no trust in others
- E4. Do you attend meetings/receive newsletters that address community related issues?
- 1 Always
 - 2 Mostly
 - 3 Occasionally
 - 4 Never
 - 5 There are no such meetings / newsletters within our community.
- E5. Please tick the option below that best indicates your initial response to being part of a community owned and operated electricity generation scheme.
- 1 I strongly support this type of scheme and am keen to be involved
 - 2 I am interested but would need further information to be convinced
 - 3 I am not interested at this stage but could be in the future
 - 4 I am not at all interested in being a part of this type of scheme

- E6. Have there been any community based projects that you have been involved with in the past? (These could have involved a couple of community members or the entire community - the size of the project is not important.) Please give details of these projects by filling out the following table. If more space is required please write on the back of this sheet.

Record your view of how successful the project was as a rating from 1 to 7, where 1 is unsuccessful and 7 is successful.

	Project 1	Project 2
Project description		
Who led the project?		
Who else was involved?		
How well did those involved worked together? (1 - 7)		

Section F - Renewable Energy

This section is intended to give me an understanding of any experience you have had with renewable energy, as well as your attitudes toward using renewable resources for electricity generation.

- F1. What experience, if any, have you had with electricity generated from renewable resources? (Please tick one or more boxes)
- 1 Presently use some electricity from renewable sources
 - 2 Have stayed in properties that use electricity from renewable sources
 - 3 Have friends who use electricity from renewable sources
 - 4 Have read literature about renewable electricity production
 - 5 No experience

F2. Have you previously investigated the possibility of installing any of the following renewable energy equipment on your property? (Please tick)

- 1 [] micro-hydro turbine
- 2 [] wind turbine
- 3 [] solar panels
- 4 [] biogas plant
- 5 [] none of these

F3. Please tick the appropriate column to indicate your response to the following suggestions for reducing you electricity consumption, where '1' indicates that you are strongly against doing it and '7' indicates that you are strongly in favour of doing it. If you already do the suggestion please tick the 'Already do it' box.

Energy Saving Suggestions.	1	2	3	4	5	6	7	Already do it
Use energy efficient light bulbs instead of standard bulbs								
Use gas or wood heating instead of electricity								
Add ceiling insulation								
Use solar water heaters								
Stop draughts around doors and windows								
Turn down the thermostat on the hot water cylinder								
Be aware of what appliances are being used and when they are being used								
Use a cylinder wrap on your hot water cylinder								
Replace old refrigerators and freezers with more efficient models								

APPENDIX C

Computer Model Inputs

Appendix C

The inputs used in the Totara Valley and D'Urville Island scenarios are provided.

C.1 Totara Valley

C.1.1 Tariff Structure

The present cost of electricity supplied from the local lines and energy companies was determined using the method described in Section A.1 and the tariff structure provided by Scanpower on 22/03/2000 (Table C.1).

Table C.1: Tariff structure used for the Totara Valley analyses

Domestic		Commercial	
Anytime (c/kWh)	6	Anytime (c/kWh)	6
Water Heating (c/kWh)	6	Water Heating (c/kWh)	6
Night Only (c/kWh)	6	Night Only (c/kWh)	6
Metering Charge (c/mth)	290	Metering Charge (c/mth)	290
Daily Line Charge (c/day)	65	Daily Line Charge (c/day)	0
Anytime Supply Charge (c/kWh)	4.45	Anytime Supply Charge (c/kWh)	4.5
Night Only Supply Charge (c/kWh)	2	Night Only Supply Charge (c/kWh)	2.2
Water Heating Supply Charge (c/kWh)	2	Water Heating Supply Charge (c/kWh)	2.2
		KVA Charge (c/KVA/mth)	235
		Average KVA	14

C.1.2 Hydro Resource and Technology

Stream B was used in the analysis for the Totara Valley community as the costs of equipment required to develop this stream for hydro electric generation were less than for Totara Stream. The potential environmental effects from developing this stream are also smaller for the following reasons:

- The stream has a culvert with a 1.5m fall at its confluence with Totara Stream, so removal of water from the bed would not affect the passage of fish up the valley. A development within the Totara Stream in the identified section could stop the

passage of fish to a number of smaller tributaries further up the valley, unless provision was made for fish passage in the design of the intake structure.

- The size of site works required to divert the water would be smaller due to the low flow available.

The other reason for selecting this stream was the absence of any dense vegetation that may block the intake structure.

The available head and water flowrate for Stream 2 have been quantified in Section 7.1.1.1. The other inputs required for the hydro section of the model are detailed below (Table C.2). Quotes for turbines were obtained from Tamar Turbines in Australia and Canyon turbines in the USA. The Tamar turbine was used in the model as it was the most cost effective.

Table C.2: Inputs used to describe the hydro development for Totara Valley

Input	Value
% Flow Allowed	90%
Pipe Length and Material	718m, PVC
Distance to Point of use	550m
Annual O and M Costs	2%
Design Life	20 years
Cost of a Resource Consent	\$300
Consents Required	Water, Land Use and Discharge Permits
Allowable Head loss	10%
Turbine Cost	\$10800
Controller Cost	\$1825
Cable Cost	\$3780
Pipe Cost	\$10353

C.1.3 Wind Resource and Technology

The monthly wind speed profile and Weibull shape parameter for Totara Valley are given in Section 7.1.1.2. Other inputs required to describe the resource are given below (Table C.3).

Table C.3: Inputs used to describe the wind resource for Totara Valley

Input	Value
Surface Roughness Coefficient	0.15 (Farmland with uncut short grass)
Turbine Design Life	20 years
Anemometer Height	10m
Annual O and M Costs	2%

C.1.4 Solar Resource and Technology

The annual variation in solar resource at Totara Valley is described in Section 7.1.1.3.

Other inputs used to define the solar resource are given below (Table C.4).

Table C.4: Inputs used to describe the solar resource at Totara Valley

Input	Value
Site Latitude	-40.4°
Site Altitude	340m a.s.l.
Panel Orientation	North
Annual O and M Costs	1%
Panel Design Life	20 years
Panel Efficiency	13%
Ground Reflectivity	0.27 (Dark Building Surfaces)

C.1.5 Storage, Transmission and Site Works

The inputs required by the storage and transmission section of the model are given below (Table C.5). The cost of site works have not been included in the analysis as they can not be accurately quantified at this stage of the system design.

Table C.5: Storage and transmission inputs used for Totara Valley

Input	Value
Days Storage Required	4
Maximum Battery Depth of Discharge	50%
Inverter Efficiency	85%
System Voltage	24V
Wintertime Average Temperature	10 °C
Annual O and M Costs	1%
Cost /km of Transmission Line	\$30000
Age of Existing Network	13 years
Life Expectancy of Network	50 years
Annual O and M Costs for Network	\$590
Present Lines Company	Scanpower

C.2 D'Urville Island

C.2.1 Variable Inputs

The variable inputs for the hydro, wind and solar sections of the model are detailed below (Table C.6). The expected power output from the hydro resource for scenario 33 is the combined total output from Streams A to D.

Table C.6: Variable inputs used for D'Urville Island scenarios

Scenario Number	HYDRO									WIND	SOLAR
	Stream Used	Output (kW)	Turbine Cost	Pipe Length	Pipe Cost	Cable Length	Cable Cost	Cost of Controller	Cost of Consent	Surface Roughness Coefficient	Latitude
1	-	-	-	-	-	-	-	-	-	0.15	40.73
2	-	-	-	-	-	-	-	-	-	0.15	40.73
3	-	-	-	-	-	-	-	-	-	0.15	40.76
4	-	-	-	-	-	-	-	-	-	0.15	40.76
5	-	-	-	-	-	-	-	-	-	0.15	40.8
6	-	-	-	-	-	-	-	-	-	0.15	40.8
7	A	5.43	15817	864	14146	1200	8400	1825	900	0.15	40.86
8	A	5.43	15817	864	14146	1200	8400	1825	900	0.15	40.86
9	B	4.54	14125	540	8761	50	350	1825	900	0.15	40.89
10	B	4.54	14125	540	8761	50	350	1825	900	0.15	40.89
11	C	8.1	16759	504	16346	50	350	1825	900	0.28	40.86
12	C	8.1	16759	504	16346	50	350	1825	900	0.28	40.86
13	-	-	-	-	-	-	-	-	-	0.28	40.87
14	-	-	-	-	-	-	-	-	-	0.28	40.87
15	-	-	-	-	-	-	-	-	-	-	40.87
16	-	-	-	-	-	-	-	-	-	-	40.87
17	-	-	-	-	-	-	-	-	-	0.28	40.91
18	-	-	-	-	-	-	-	-	-	0.28	40.91
19	-	-	-	-	-	-	-	-	-	0.28	40.93
20	-	-	-	-	-	-	-	-	-	0.28	40.93
21	-	-	-	-	-	-	-	-	-	0.15	40.94
22	-	-	-	-	-	-	-	-	-	0.15	40.94
23	-	-	-	-	-	-	-	-	-	0.15	40.75
24	-	-	-	-	-	-	-	-	-	0.15	40.75
25	A,B	9.97	29942	1404	22907	1250	8750	3650	1800	0.15	40.85
26	A,B	9.97	29942	1404	22907	1250	8750	3650	1800	0.15	40.85
27	A	5.43	15817	864	14146	1200	8400	1825	900	0.15	40.8
28	A	5.43	15817	864	14146	1200	8400	1825	900	0.15	40.8
29	C	8.1	16759	672	16346	50	350	1825	900	0.28	40.74
30	C	8.1	16759	672	16346	50	350	1825	900	0.28	40.74
31	D	5.43	15817	864	14146	50	350	1825	900	0.15	40.93
32	D	5.43	15817	864	14146	50	350	1825	900	0.15	40.93
33	A - D	34	63652	-	53399	1350	9450	7300	3600	0.15	40.83
34	-	-	-	-	-	-	-	-	-	0.15	40.83

C.2.2 Tariff Structure

The present cost of electricity supplied from the National Grid was determined using the method described in Section A.1 and the tariff structure provided by Marlborough Lines and Trust Power on 30/04/2000 (Table C.7).

Table C.7: Tariff structure used for the D'Urville Island analyses

Domestic		Commercial	
Anytime (c/kWh)	11.37	Anytime (c/kWh)	13.42
Water Heating (c/kWh)	9.3	Water Heating (c/kWh)	9.35
Night Only (c/kWh)	7.29	Night Only (c/kWh)	7.44
Metering Charge (c/mth)	3862	Metering Charge (c/mth)	5718
Daily Line Charge (c/day)	83.7	Daily Line Charge (c/day)	1.369
Anytime Supply Charge (c/kWh)	3.771	Anytime Supply Charge (c/kWh)	5.698
Night Only Supply Charge (c/kWh)	2.351	Night Only Supply Charge (c/kWh)	0.925
Water Heating Supply Charge (c/kWh)	0.925	Water Heating Supply Charge (c/kWh)	0.869

C.2.3 Hydro Resource and Technology

Four streams have been used in the scenarios investigated for D'Urville Island. The inputs that apply to all streams are shown below (Table C.8). The percentage of flow allowed has been set at 90%, but this would depend on resource consents being granted for this level of abstraction.

Table C.8: Fixed inputs used to describe the hydro development for D'Urville Island

Input	Value
% Flow Allowed	90%
Pipe Material	Polyethylene
Annual O and M Costs	2%
Design Life	20 years
Cost of a Resource Consent	\$300
Consents Required	Water, Land Use and Discharge Permits
Allowable Head loss	10%

C.2.4 Wind Resource and Technology

The monthly wind speed profile and Weibull Shape parameter for D'Urville Island are given in Section 7.2.1.2. Although wind data has only been obtained from one site, it has been assumed that the same wind resource is available for all the scenarios. Other inputs required to describe the wind resource are given below (Table C.9).

Table C.9: Fixed inputs used to describe the wind resource for D'Urville Island

Input	Value
Turbine Design Life	20 years
Anemometer Height	10m
Annual O and M Costs	2%

C.2.5 Solar Resource and Technology

The annual variation in the solar resource at D'Urville Island is described in Section 7.2.1.3. Other inputs used to define the solar resource are given below (Table C.10).

Table C.10: Fixed inputs used to describe the solar resource at D'Urville Island

Input	Value
Panel Orientation	N
Altitude	20m a.s.l.
Annual O and M Costs	1%
Panel Design Life	20 years
Panel Efficiency	13%
Ground Reflectivity	0.27 (Dark Building Surfaces)

C.2.6 Storage, Transmission and Site Works

The inputs required by the storage and transmission section of the model are given below (Table C.11). The cost of site works have not been included in the analysis as they can not be accurately defined at this stage of the system design.

Table C.11: Storage and transmission inputs used for D'Urville Island

Input	Value
Days Storage Required	4
Maximum Battery Depth of Discharge	50%
Inverter Efficiency	85%
System Voltage	24V
Wintertime Average Temperature	10 °C
Annual O and M Costs	1%
Cost /km of Transmission Line	\$20000
Age of Existing Network	19 years
Life Expectancy of Network	38 years
Annual O and M Costs for Network	\$600
Present Lines Company	Marlborough Lines

APPENDIX D

Totara Valley Scenario Summary Sheets

Scenario 1



Renewable Communities

Scenario Summary

Community / Client Name: <u>Totara Valley</u>	Contact Phone: _____
Contact Person: _____	Contact E-mail: _____
Contact Address: _____	Date: <u>26/04/00</u>
Type of Analysis: <u>Individual Members</u>	

ENERGY RESOURCES AVAILABLE: Hydro Wind Solar

Hydro	Type of Turbine: <u>Pelton</u>	Penstock Length (m): <u>718</u>	
	Turbine Rating (kW): <u>2.10</u>	Penstock Diameter (m): <u>0.051</u>	
Wind	Turbine Model: <u>Whisper 3000</u>	Controller Included (Y/N): <u>Y</u>	
	Number Required: <u>11</u>	Data Type (Annual/Monthly): <u>Monthly</u>	
Solar	Panel Area (m ²): <u>15.1</u>	Rating of Panel array (Wp): <u>1644</u>	
	Optimised Panel Slope (°): <u>37</u>		
Storage & Network	Battery Make: <u>Trojan</u>	Inverter Make: <u>Trace</u>	
	Battery Model: <u>T105</u>	Inverter Model: <u>DR2424E</u>	
	Number Required: <u>1436</u>	Number Required: <u>15</u>	
	Days Storage Provided: <u>4</u>	Length of Network Lines (km): <u>2.5</u>	

ECONOMICS

Total NPV (\$NZ): <u>1195385</u>	c/kWh produced: <u>106.6</u>
Total Capital Cost (\$NZ): <u>541834</u>	Water Heating Included (Y/N): <u>Y</u>
Annual Cost to Community/Customer (NZ\$): <u>121753</u>	
Annual Cost of maintaining existing grid connection (NZ\$): <u>11993</u>	

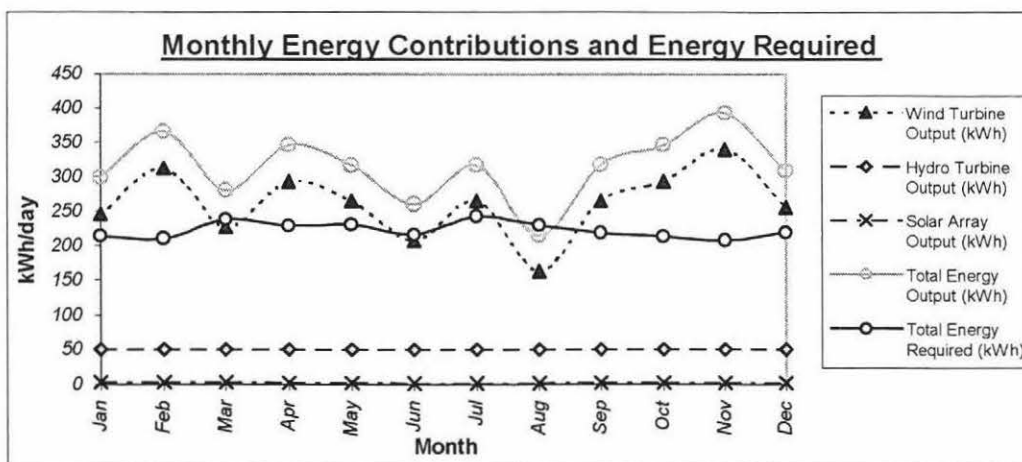

Scenario 2



Renewable Communities

Scenario Summary

Community / Client Name: Totara Valley Contact Phone: _____
 Contact Person: _____ Contact E-mail: _____
 Contact Address: _____ Date: 26/04/00
 Type of Analysis: Individual Members

ENERGY RESOURCES AVAILABLE: Hydro Wind Solar

Hydro Type of Turbine: Pelton Penstock Length (m): 718
 Turbine Rating (kW): 2.10 Penstock Diameter (m): 0.051

Wind Turbine Model: Whisper 3000 Controller Included (Y/N): Y
 Number Required: 8 Data Type (Annual/Monthly): Monthly

Solar Panel Area (m²): Not Required Rating of Panel array (Wp): _____
 Optimised Panel Slope (°): _____

Storage & Network Battery Make: Trojan Inverter Make: Trace
 Battery Model: T105 Inverter Model: DR2424E
 Number Required: 944 Number Required: 14
 Days Storage Provided: 4 Length of Network Lines (km): 2.5

ECONOMICS

Total NPV (\$NZ): 837640 c/kWh produced: 97.4
 Total Capital Cost (\$NZ): 373617 Water Heating Included (Y/N): N
 Annual Cost to Community/Customer (NZ\$): 85316

Annual Cost of maintaining existing grid connection (NZ\$): 10381

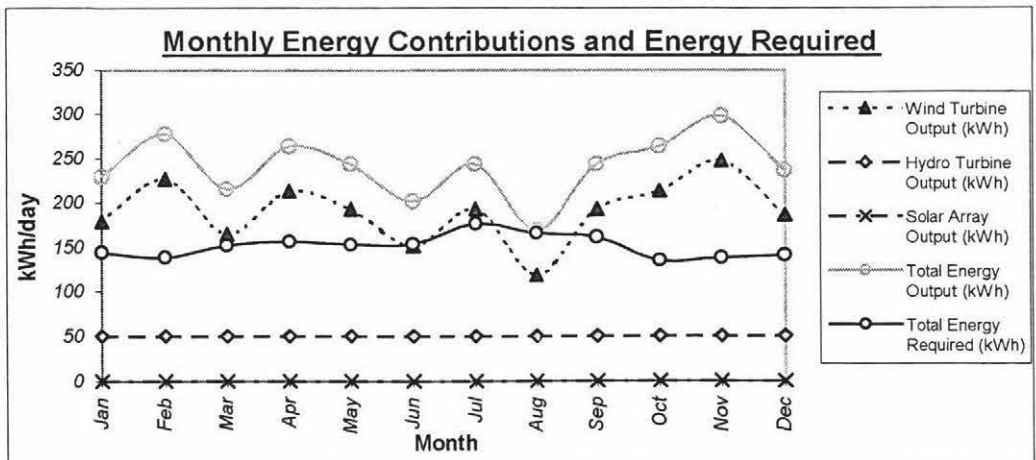

Scenario 3



Renewable Communities

Scenario Summary

Community / Client Name: <u>Totara Valley</u>	Contact Phone: _____
Contact Person: _____	Contact E-mail: _____
Contact Address: _____	Date: <u>26/04/00</u>
Type of Analysis: <u>Individual Members</u>	

ENERGY RESOURCES AVAILABLE: Hydro Wind Solar

Hydro	Type of Turbine: <u>Pelton</u>	Penstock Length (m): <u>718</u>	
	Turbine Rating (kW): <u>2.10</u>	Penstock Diameter (m): <u>0.051</u>	
Wind	Turbine Model: <u>Whisper 3000</u>	Controller Included (Y/N): <u>Y</u>	
	Number Required: <u>11</u>	Data Type (Annual/Monthly): <u>Monthly</u>	
Solar	Panel Area (m ²): <u>Not Required</u>	Rating of Panel array (Wp): _____	
	Optimised Panel Slope (°): _____		
Storage & Network	Battery Make: <u>Trojan</u>	Inverter Make: <u>Trace</u>	
	Battery Model: <u>T105</u>	Inverter Model: <u>DR2424E</u>	
	Number Required: <u>1240</u>	Number Required: <u>13</u>	
	Days Storage Provided: <u>4</u>	Length of Network Lines (km): <u>1.75</u>	

ECONOMICS

Total NPV (\$NZ): <u>1023464</u>	c/kWh produced: <u>91.8</u>
Total Capital Cost (\$NZ): <u>470875</u>	Water Heating Included (Y/N): <u>Y</u>
Annual Cost to Community/Customer (NZ\$): <u>104242</u>	
Annual Cost of maintaining existing grid connection (NZ\$): <u>10760</u>	

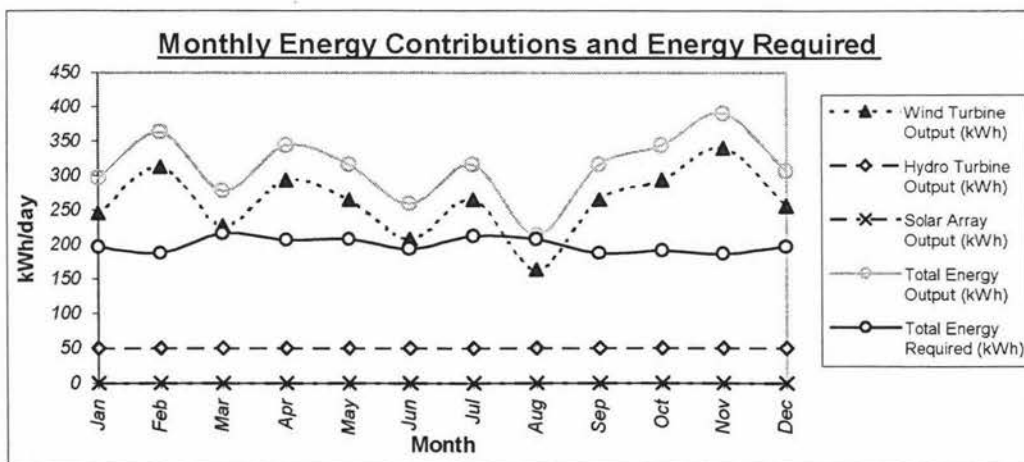

Scenario 4



Renewable Communities

Scenario Summary

Community / Client Name: Totara Valley Contact Phone: _____
 Contact Person: _____ Contact E-mail: _____
 Contact Address: _____ Date: 26/04/00
 Type of Analysis: Individual Members

ENERGY RESOURCES AVAILABLE: Hydro Wind Solar

Hydro Type of Turbine: Pelton Penstock Length (m): 718
 Turbine Rating (kW): 2.10 Penstock Diameter (m): 0.051

Wind Turbine Model: Whisper 3000 Controller Included (Y/N): Y
 Number Required: 7 Data Type (Annual/Monthly): Monthly

Solar Panel Area (m²): 2.5 Rating of Panel array (Wp): 271
 Optimised Panel Slope (°): 37

Storage & Network Battery Make: Trojan Inverter Make: Trace
 Battery Model: T105 Inverter Model: DR2424E
 Number Required: 840 Number Required: 8
 Days Storage Provided: 4 Length of Network Lines (km): 1.75

ECONOMICS

Total NPV (\$NZ): 719139 c/kWh produced: 92.7
 Total Capital Cost (\$NZ): 323751 Water Heating Included (Y/N): N
 Annual Cost to Community/Customer (NZ\$): 73246
 Annual Cost of maintaining existing grid connection (NZ\$): 9433

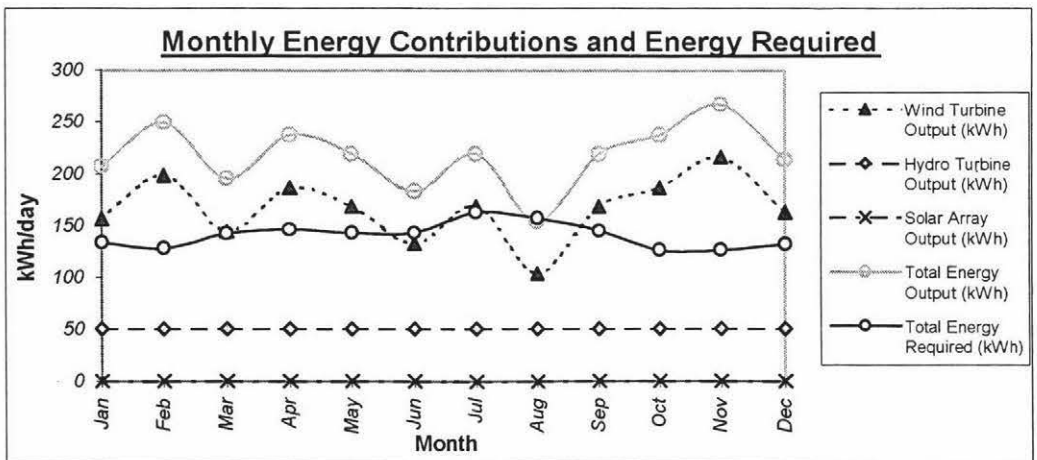

Scenario 5



Renewable Communities

Scenario Summary

Community / Client Name: Totara Valley Contact Phone: _____
 Contact Person: _____ Contact E-mail: _____
 Contact Address: _____ Date: 26/04/00
 Type of Analysis: Individual Members

ENERGY RESOURCES AVAILABLE: **Hydro** **Wind** **Solar**

Hydro	Type of Turbine:	<u>Pelton</u>	Penstock Length (m)	<u>718</u>
	Turbine Rating (kW):	<u>2.10</u>	Penstock Diameter (m):	<u>0.051</u>
Wind	Turbine Model:	<u>Whisper 3000</u>	Controller Included (Y/N):	<u>Y</u>
	Number Required:	<u>6</u>	Data Type (Annual/Monthly)	<u>Monthly</u>
Solar	Panel Area (m ²):	<u>7.7</u>	Rating of Panel array (Wp):	<u>841</u>
	Optimised Panel Slope (°):	<u>37</u>		
Storage & Network	Battery Make:	<u>Trojan</u>	Inverter Make:	<u>Trace</u>
	Battery Model:	<u>T105</u>	Inverter Model:	<u>DR2424E</u>
	Number Required:	<u>844</u>	Number Required:	<u>7</u>
	Days Storage Provided:	<u>4</u>	Length of Network Lines (km):	<u>0.3</u>

ECONOMICS

Total NPV (\$NZ): 658392 c/kWh produced: 94.9
 Total Capital Cost (\$NZ): 318809 Water Heating Included (Y/N): Y
 Annual Cost to Community/Customer (NZ\$): 67059
 Annual Cost of maintaining existing grid connection (NZ\$): 7244

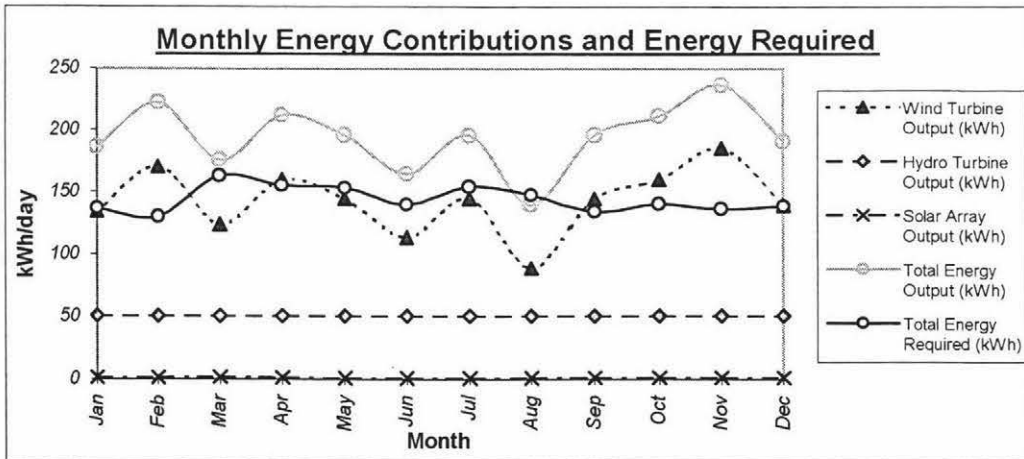

Scenario 7



Renewable Communities

Scenario Summary

Community / Client Name: <u>Totara Valley</u>	Contact Phone: _____
Contact Person: _____	Contact E-mail: _____
Contact Address: _____	Date: <u>26.04.00</u>
Type of Analysis: <u>Individual Members</u>	

ENERGY RESOURCES AVAILABLE: Hydro Wind Solar

Hydro	Type of Turbine: <u>Pelton</u>	Penstock Length (m): <u>718</u>	
	Turbine Rating (kW): <u>2.10</u>	Penstock Diameter (m): <u>0.051</u>	
Wind	Turbine Model: <u>Whisper 3000</u>	Controller Included (Y/N): <u>Y</u>	
	Number Required: <u>2</u>	Data Type (Annual/Monthly): <u>Monthly</u>	
Solar	Panel Area (m ²): <u>Not Required</u>	Rating of Panel array (Wp): _____	
	Optimised Panel Slope (°): _____		
Storage & Network	Battery Make: <u>Trojan</u>	Inverter Make: <u>Trace</u>	
	Battery Model: <u>T105</u>	Inverter Model: <u>DR2424E</u>	
	Number Required: <u>280</u>	Number Required: <u>5</u>	
	Days Storage Provided: <u>4</u>	Length of Network Lines (km): <u>0</u>	

ECONOMICS

Total NPV (\$NZ): <u>238858</u>	c/kWh produced: <u>68.2</u>
Total Capital Cost (\$NZ): <u>128111</u>	Water Heating Included (Y/N): <u>Y</u>
Annual Cost to Community/Customer (NZ\$): <u>24328</u>	
Annual Cost of maintaining existing grid connection (NZ\$): <u>3961</u>	

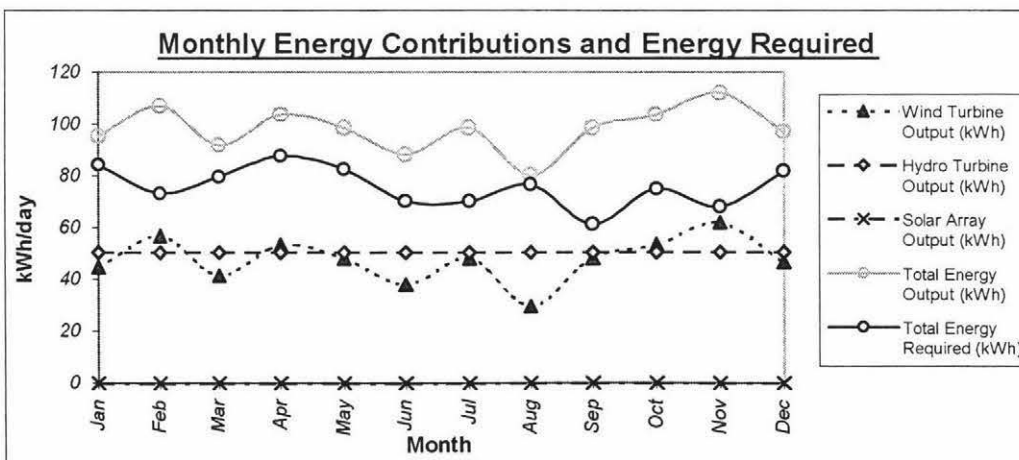

Scenario 8



Renewable Communities

Scenario Summary

Community / Client Name: Totara Valley Contact Phone: _____
 Contact Person: _____ Contact E-mail: _____
 Contact Address: _____ Date: 26/04/00
 Type of Analysis: Individual Members

ENERGY RESOURCES AVAILABLE: Hydro Wind Solar

Hydro Type of Turbine: Pelton Penstock Length (m): 718
 Turbine Rating (kW): 2.10 Penstock Diameter (m): 0.051

Wind Turbine Model: Soma 1000 Controller Included (Y/N): Y
 Number Required: 1 Data Type (Annual/Monthly): Monthly

Solar Panel Area (m²): 0.5 Rating of Panel array (Wp): 53
 Optimised Panel Slope (°): 37

Storage & Network Battery Make: Trojan Inverter Make: Trace
 Battery Model: T105 Inverter Model: DR2424E
 Number Required: 60 Number Required: 4
 Days Storage Provided: 4 Length of Network Lines (km): 0

ECONOMICS

Total NPV (\$NZ): 88117 c/kWh produced: 40.5
 Total Capital Cost (\$NZ): 59722 Water Heating Included (Y/N): N
 Annual Cost to Community/Customer (NZ\$): 8975

Annual Cost of maintaining existing grid connection (NZ\$): 3384

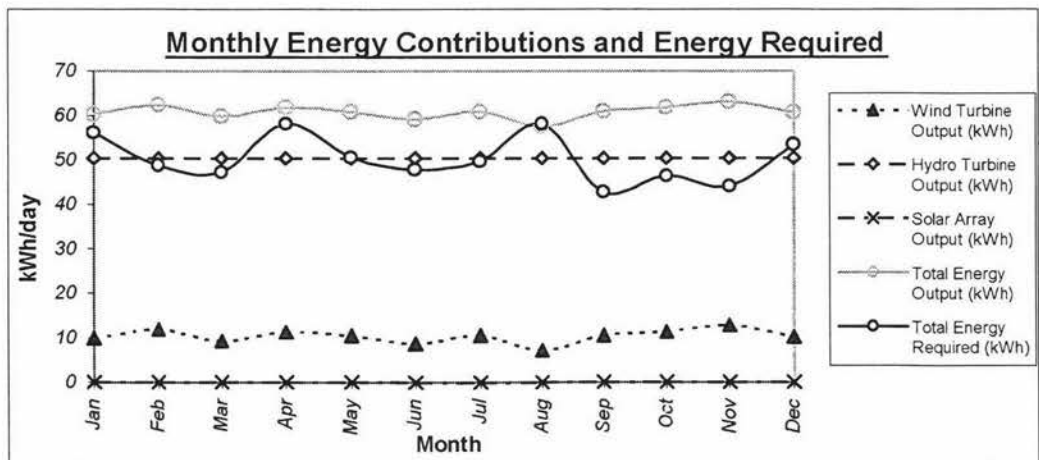

Scenario 9



Renewable Communities

Scenario Summary

Community / Client Name: Totara Valley Contact Phone: _____
 Contact Person: _____ Contact E-mail: _____
 Contact Address: _____ Date: 26/04/00
 Type of Analysis: Individual Members

ENERGY RESOURCES AVAILABLE: Hydro Wind Solar

Hydro Type of Turbine: Not Available Penstock Length (m): _____
 Turbine Rating (kW): _____ Penstock Diameter (m): _____

Wind Turbine Model: Jacobs 29-20 Controller Included (Y/N): Y
 Number Required: 1 Data Type (Annual/Monthly): Monthly

Solar Panel Area (m²): Not Required Rating of Panel array (Wp): _____
 Optimised Panel Slope (°): _____

Storage & Network Battery Make: Trojan Inverter Make: Trace
 Battery Model: T105 Inverter Model: DR2424E
 Number Required: 632 Number Required: 7
 Days Storage Provided: 4 Length of Network Lines (km): 0

ECONOMICS

Total NPV (SNZ): 467471 c/kWh produced: 104.4
 Total Capital Cost (SNZ): 231806 Water Heating Included (Y/N): Y
 Annual Cost to Community/Customer (NZ\$): 47613
 Annual Cost of maintaining existing grid connection (NZ\$): 3283

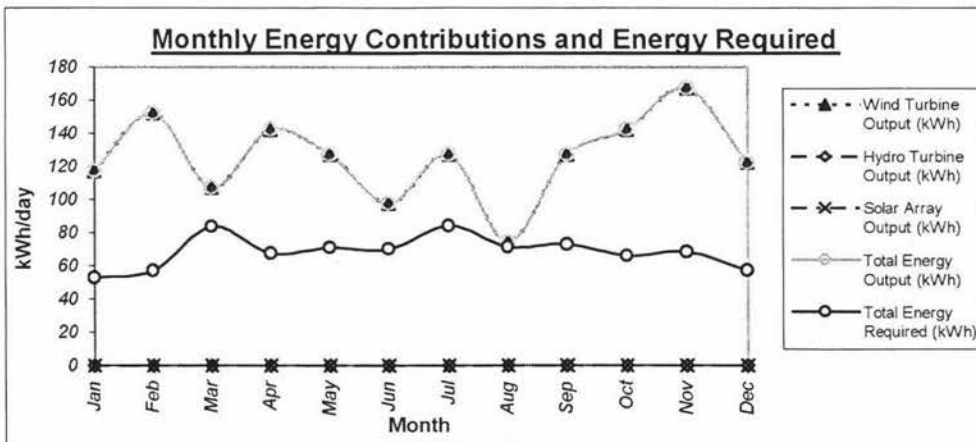

Scenario 10



Renewable Communities

Scenario Summary

Community / Client Name: Totara Valley Contact Phone: _____
 Contact Person: _____ Contact E-mail: _____
 Contact Address: _____ Date: 26/04/00
 Type of Analysis: Individual Members

ENERGY RESOURCES AVAILABLE: Hydro Wind Solar

Hydro Type of Turbine: Not Available Penstock Length (m): _____
 Turbine Rating (kW): _____ Penstock Diameter (m): _____

Wind Turbine Model: Whisper 3000 Controller Included (Y/N): Y
 Number Required: 3 Data Type (Annual/Monthly): Monthly

Solar Panel Area (m²): 9.9 Rating of Panel array (Wp): 1077
 Optimised Panel Slope (°): 37

Storage & Network Battery Make: Trojan Inverter Make: Trace
 Battery Model: T105 Inverter Model: DR2424E
 Number Required: 504 Number Required: 6
 Days Storage Provided: 4 Length of Network Lines (km): 0

ECONOMICS

Total NPV (\$NZ): 374112 c/kWh produced: 144.2
 Total Capital Cost (\$NZ): 182830 Water Heating Included (Y/N): N
 Annual Cost to Community/Customer (NZ\$): 38104

Annual Cost of maintaining existing grid connection (NZ\$): 2844

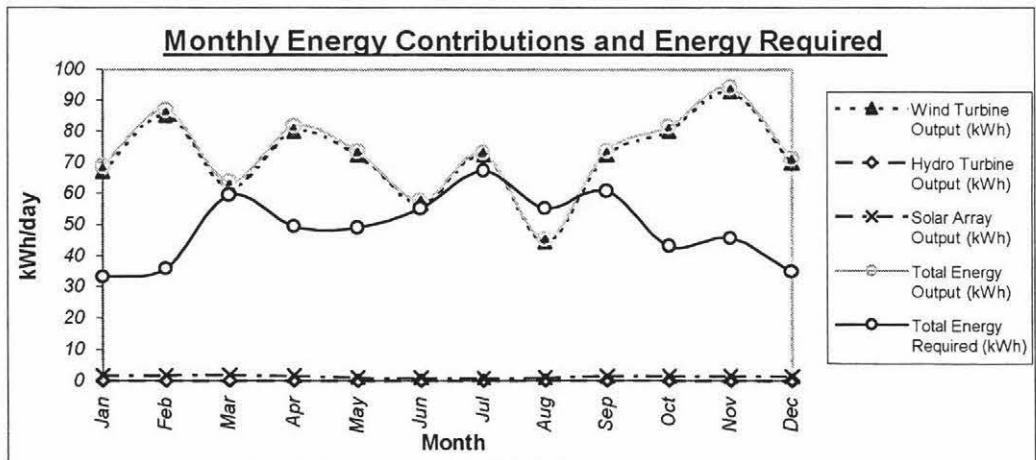

Scenario 11



Renewable Communities

Scenario Summary

Community / Client Name: Totara Valley Contact Phone: _____
 Contact Person: _____ Contact E-mail: _____
 Contact Address: _____ Date: 26/04/00
 Type of Analysis: Individual Members

ENERGY RESOURCES AVAILABLE: Hydro Wind Solar

Hydro Type of Turbine: Not Available Penstock Length (m): _____
 Turbine Rating (kW): _____ Penstock Diameter (m): _____

Wind Turbine Model: Whisper 3000 Controller Included (Y/N): Y
 Number Required: 4 Data Type (Annual/Monthly): Monthly

Solar Panel Area (m²): 0.5 Rating of Panel array (Wp): 56
 Optimised Panel Slope (°): 37

Storage & Network Battery Make: Trojan Inverter Make: Trace
 Battery Model: T105 Inverter Model: DR2424E
 Number Required: 448 Number Required: 9
 Days Storage Provided: 4 Length of Network Lines (km): 0

ECONOMICS

Total NPV (\$NZ): 349761 c/kWh produced: 102.9
 Total Capital Cost (\$NZ): 176352 Water Heating Included (Y/N): Y
 Annual Cost to Community/Customer (NZ\$): 35624
 Annual Cost of maintaining existing grid connection (NZ\$): 3516

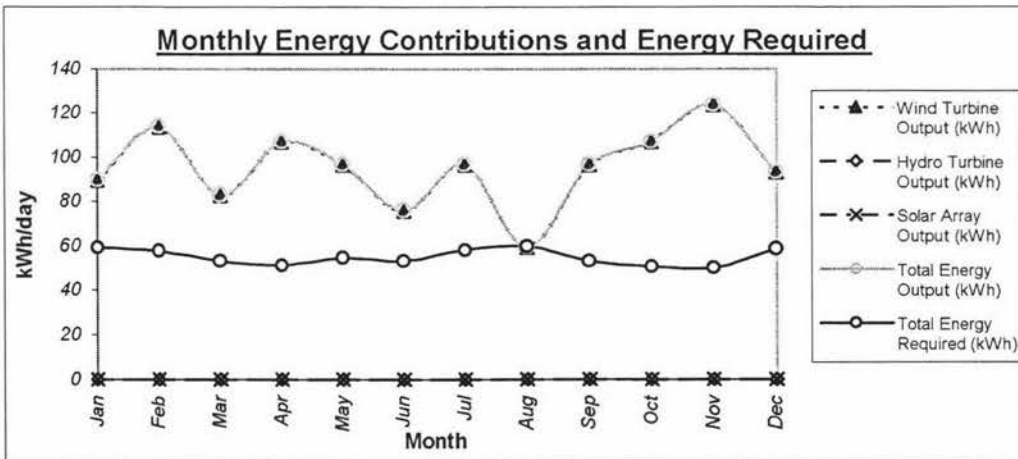

Scenario 12



Renewable Communities

Scenario Summary

Community / Client Name: Totara Valley Contact Phone: _____
 Contact Person: _____ Contact E-mail: _____
 Contact Address: _____ Date: 26/04/00
 Type of Analysis: Individual Members

ENERGY RESOURCES AVAILABLE: Hydro Wind Solar

Hydro Type of Turbine: Not Available Penstock Length (m): _____
 Turbine Rating (kW): _____ Penstock Diameter (m): _____

Wind Turbine Model: Whisper 3000 Controller Included (Y/N): Y
 Number Required: 3 Data Type (Annual/Monthly): Monthly

Solar Panel Area (m²): Not Required Rating of Panel array (Wp): _____
 Optimised Panel Slope (°): _____

Storage & Network Battery Make: Trojan Inverter Make: Trace
 Battery Model: T105 Inverter Model: DR2424E
 Number Required: 344 Number Required: 8
 Days Storage Provided: 4 Length of Network Lines (km): 0

ECONOMICS

Total NPV (SNZ): 270302 c/kWh produced: 106.1
 Total Capital Cost (SNZ): 137889 Water Heating Included (Y/N): N
 Annual Cost to Community/Customer (NZ\$): 27531
 Annual Cost of maintaining existing grid connection (NZ\$): 3205

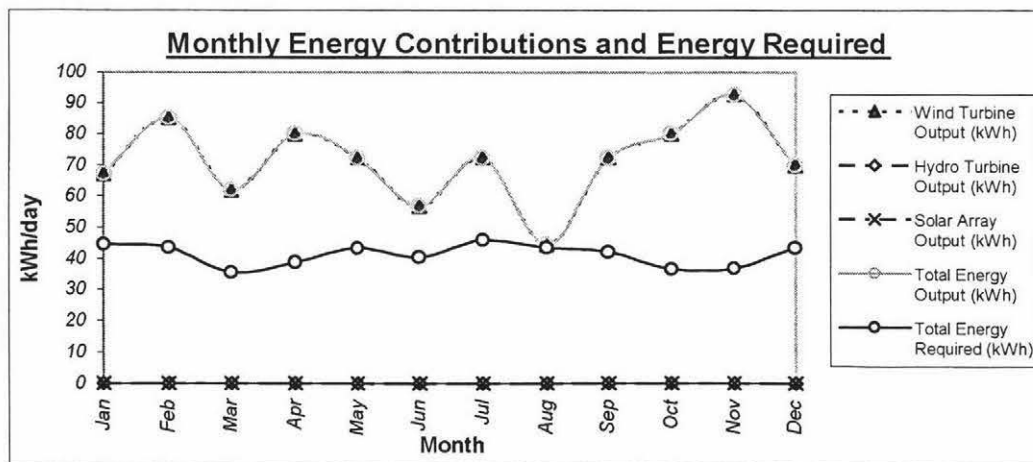

Scenario 13



Renewable Communities

Scenario Summary

Community / Client Name: <u>Totara Valley</u>	Contact Phone: _____
Contact Person: _____	Contact E-mail: _____
Contact Address: _____	Date: <u>26/04/00</u>
Type of Analysis: <u>Individual Members</u>	

ENERGY RESOURCES AVAILABLE: Hydro Wind Solar

Hydro	Type of Turbine: <u>Not Available</u>	Penstock Length (m): _____
	Turbine Rating (kW): _____	Penstock Diameter (m): _____
Wind	Turbine Model: <u>Whisper 3000</u>	Controller Included (Y/N): <u>Y</u>
	Number Required: <u>2</u>	Data Type (Annual/Monthly): <u>Monthly</u>
Solar	Panel Area (m ²): <u>Not Required</u>	Rating of Panel array (Wp): _____
	Optimised Panel Slope (°): _____	
Storage & Network	Battery Make: <u>Trojan</u>	Inverter Make: <u>Trace</u>
	Battery Model: <u>T105</u>	Inverter Model: <u>DR2424E</u>
	Number Required: <u>232</u>	Number Required: <u>8</u>
	Days Storage Provided: <u>4</u>	Length of Network Lines (km): <u>0</u>

ECONOMICS

Total NPV (\$NZ): <u>189799</u>	c/kWh produced: <u>111.8</u>
Total Capital Cost (\$NZ): <u>101053</u>	Water Heating Included (Y/N): <u>Y</u>
Annual Cost to Community/Customer (NZ\$): <u>19331</u>	
Annual Cost of maintaining existing grid connection (NZ\$): <u>1232</u>	

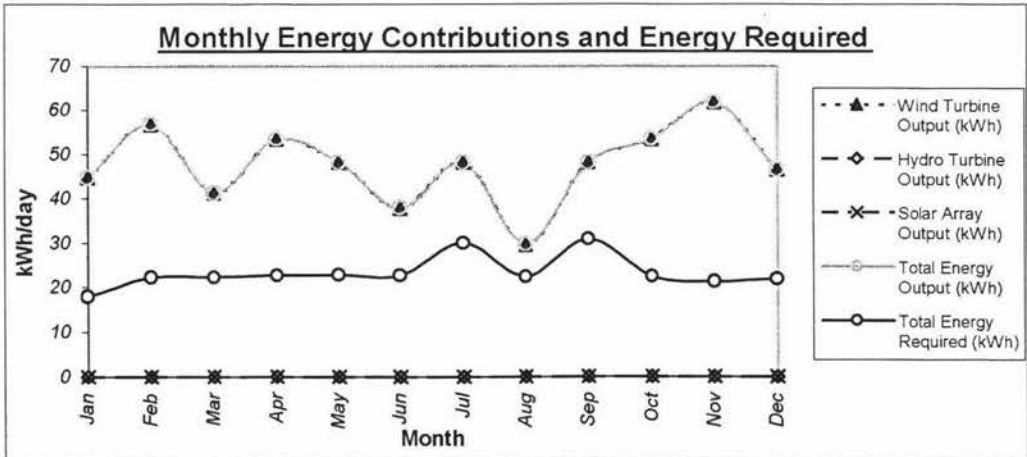

Scenario 14



Renewable Communities

Scenario Summary

Community / Client Name: Totara Valley Contact Phone: _____
 Contact Person: _____ Contact E-mail: _____
 Contact Address: _____ Date: 26/04/00
 Type of Analysis: Individual Members

ENERGY RESOURCES AVAILABLE: Hydro Wind Solar

Hydro Type of Turbine: Not Available Penstock Length (m): _____
 Turbine Rating (kW): _____ Penstock Diameter (m): _____

Wind Turbine Model: Whisper 3000 Controller Included (Y/N): Y
 Number Required: 1 Data Type (Annual/Monthly): Monthly

Solar Panel Area (m²): Not Required Rating of Panel array (Wp): _____
 Optimised Panel Slope (°): _____

Storage & Network Battery Make: Trojan Inverter Make: Trace
 Battery Model: T105 Inverter Model: DR2424E
 Number Required: 120 Number Required: 7
 Days Storage Provided: 4 Length of Network Lines (km): 0

ECONOMICS

Total NPV (\$NZ): 106315 c/kWh produced: 125.2
 Total Capital Cost (\$NZ): 61267 Water Heating Included (Y/N): N
 Annual Cost to Community/Customer (NZ\$): 10828

Annual Cost of maintaining existing grid connection (NZ\$): 948

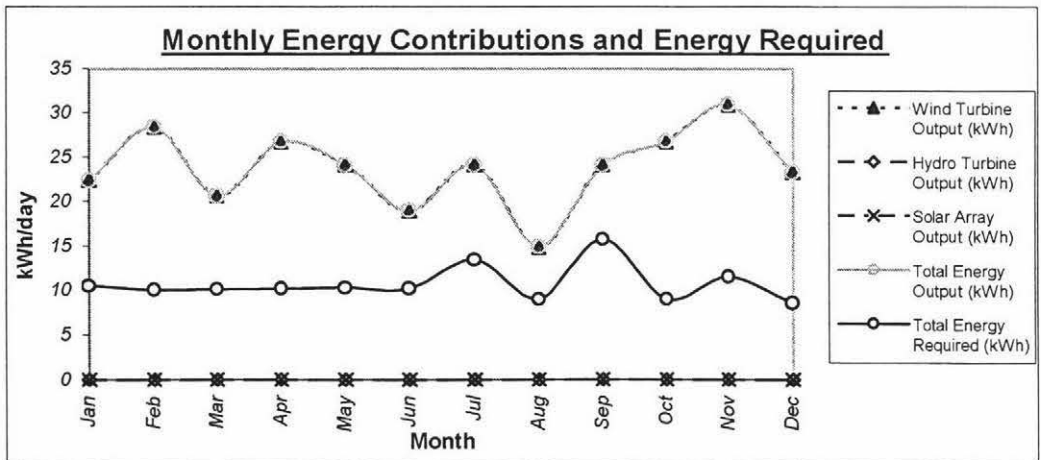

APPENDIX E

D'Urville Island Scenario Summary Sheets

Scenario 2



Renewable Communities

Scenario Summary

Community / Client Name: D'Urville Island Contact Phone: _____
 Contact Person: _____ Contact E-mail: _____
 Contact Address: _____ Date: 1/05/00
 Type of Analysis: Individual Members

ENERGY RESOURCES AVAILABLE: Hydro Wind Solar

Hydro Type of Turbine: Not Available Penstock Length (m): _____
 Turbine Rating (kW): _____ Penstock Diameter (m): _____

Wind Turbine Model: Whisper 3000 Controller Included (Y/N): Y
 Number Required: 1 Data Type (Annual/Monthly): Annual

Solar Panel Area (m²): Not Required Rating of Panel array (Wp): _____
 Optimised Panel Slope (°): _____

Storage & Network Battery Make: Trojan Inverter Make: Trace
 Battery Model: T105 Inverter Model: DR2424E
 Number Required: 256 Number Required: 5
 Days Storage Provided: 4 Length of Network Lines (km): 0

ECONOMICS

Total NPV (\$NZ): 183825 c/kWh produced: 123.4
 Total Capital Cost (\$NZ): 90387 Water Heating Included (Y/N): N
 Annual Cost to Community/Customer (NZ\$): 18723
 Annual Cost of maintaining existing grid connection (NZ\$): 3982

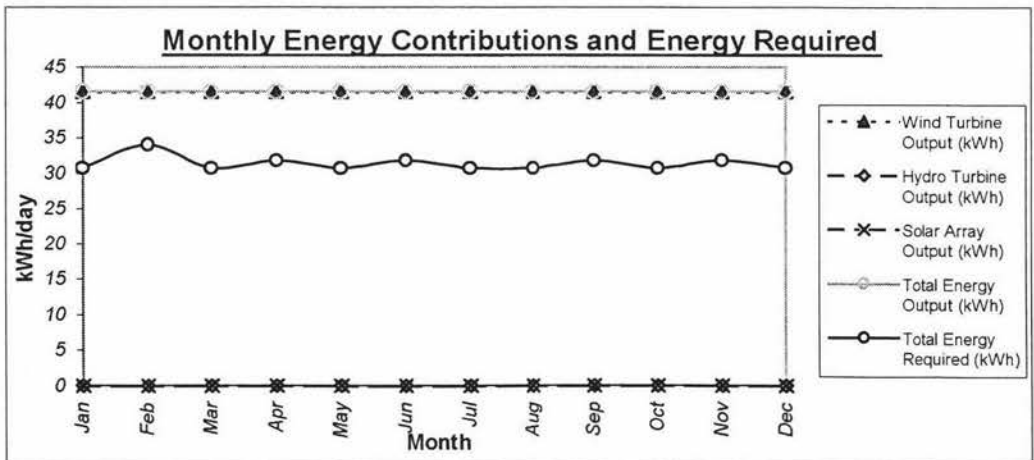

Scenario 3



Renewable Communities

Scenario Summary

Community / Client Name: <u>D'Urville Island</u>	Contact Phone: _____
Contact Person: _____	Contact E-mail: _____
Contact Address: _____	Date: <u>1/05/00</u>
Type of Analysis: <u>Individual Members</u>	

ENERGY RESOURCES AVAILABLE: Hydro Wind Solar

Hydro	Type of Turbine: <u>Not Available</u>	Penstock Length (m): _____	
	Turbine Rating (kW): _____	Penstock Diameter (m): _____	
Wind	Turbine Model: <u>Whisper 3000</u>	Controller Included (Y/N): <u>Y</u>	
	Number Required: <u>1</u>	Data Type (Annual/Monthly): <u>Annual</u>	
Solar	Panel Area (m ²): <u>Not Required</u>	Rating of Panel array (Wp): _____	
	Optimised Panel Slope (°): _____		
Storage & Network	Battery Make: <u>Trojan</u>	Inverter Make: <u>Trace</u>	
	Battery Model: <u>T105</u>	Inverter Model: <u>DR2424E</u>	
	Number Required: <u>160</u>	Number Required: <u>7</u>	
	Days Storage Provided: <u>4</u>	Length of Network Lines (km): <u>0</u>	

ECONOMICS

Total NPV (\$NZ): <u>130866</u>	c/kWh produced: <u>87.8</u>
Total Capital Cost (\$NZ): <u>71567</u>	Water Heating Included (Y/N): <u>Y</u>
Annual Cost to Community/Customer (NZ\$): <u>13329</u>	
Annual Cost of maintaining existing grid connection (NZ\$): <u>1931</u>	

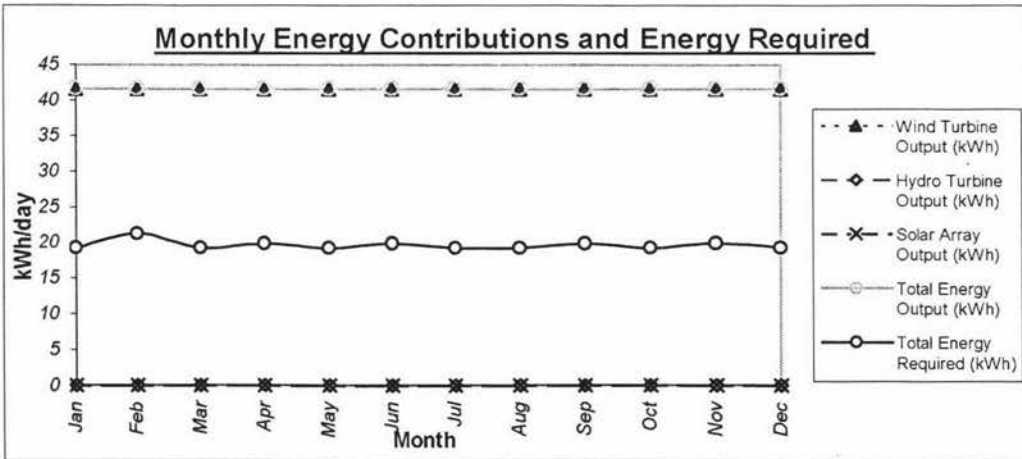

Scenario 4



Renewable Communities

Scenario Summary

Community / Client Name: D'Urville Island Contact Phone: _____
 Contact Person: _____ Contact E-mail: _____
 Contact Address: _____ Date: 1/05/00
 Type of Analysis: Individual Members

ENERGY RESOURCES AVAILABLE: Hydro Wind Solar

Hydro Type of Turbine: Not Available Penstock Length (m): _____
 Turbine Rating (kW): _____ Penstock Diameter (m): _____

Wind Turbine Model: Soma 1000 Controller Included (Y/N): Y
 Number Required: 1 Data Type (Annual/Monthly): Annual

Solar Panel Area (m²): Not Required Rating of Panel array (Wp): _____
 Optimised Panel Slope (°): _____

Storage & Network Battery Make: Trojan Inverter Make: Trace
 Battery Model: T105 Inverter Model: DR2424E
 Number Required: 88 Number Required: 6
 Days Storage Provided: 4 Length of Network Lines (km): 0

ECONOMICS

Total NPV (\$NZ): 81880 c/kWh produced: 144.1
 Total Capital Cost (\$NZ): 48581 Water Heating Included (Y/N): N
 Annual Cost to Community/Customer (NZ\$): 8340
 Annual Cost of maintaining existing grid connection (NZ\$): 1609

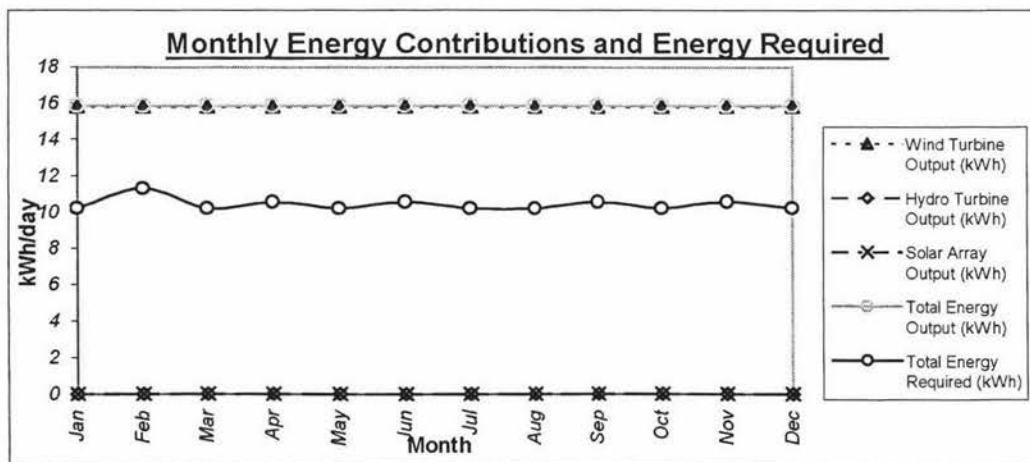

Scenario 5



Renewable Communities

Scenario Summary

Community / Client Name: <u>D'Urville Island</u>	Contact Phone: _____
Contact Person: _____	Contact E-mail: _____
Contact Address: _____	Date: <u>1/05/00</u>
Type of Analysis: <u>Individual Members</u>	

ENERGY RESOURCES AVAILABLE: Hydro Wind Solar

Hydro	Type of Turbine: <u>Not Available</u>	Penstock Length (m): _____	
	Turbine Rating (kW): _____	Penstock Diameter (m): _____	
Wind	Turbine Model: <u>Whisper 3000</u>	Controller Included (Y/N): <u>Y</u>	
	Number Required: <u>1</u>	Data Type (Annual/Monthly): <u>Annual</u>	
Solar	Panel Area (m ²): <u>Not Required</u>	Rating of Panel array (Wp): _____	
	Optimised Panel Slope (°): _____		
Storage & Network	Battery Make: <u>Trojan</u>	Inverter Make: <u>Trace</u>	
	Battery Model: <u>T105</u>	Inverter Model: <u>DR2424E</u>	
	Number Required: <u>260</u>	Number Required: <u>7</u>	
	Days Storage Provided: <u>4</u>	Length of Network Lines (km): <u>0</u>	

ECONOMICS

Total NPV (\$NZ): <u>192243</u>	c/kWh produced: <u>129.0</u>
Total Capital Cost (\$NZ): <u>97317</u>	Water Heating Included (Y/N): <u>Y</u>
Annual Cost to Community/Customer (NZ\$): <u>19580</u>	
Annual Cost of maintaining existing grid connection (NZ\$): <u>2501</u>	

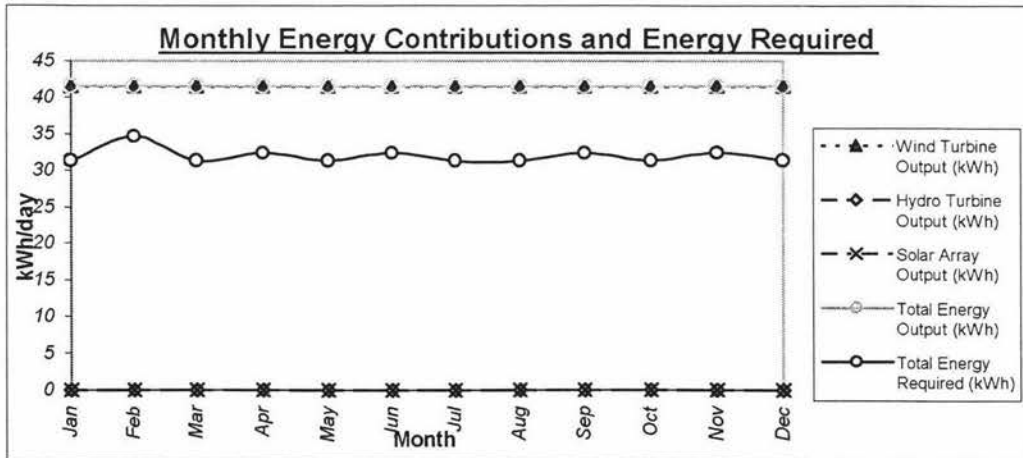

Scenario 6



Renewable Communities

Scenario Summary

Community / Client Name: D'Urville Island Contact Phone: _____
 Contact Person: _____ Contact E-mail: _____
 Contact Address: _____ Date: 1/05/00
 Type of Analysis: Individual Members

ENERGY RESOURCES AVAILABLE: Hydro Wind Solar

Hydro Type of Turbine: Not Available Penstock Length (m): _____
 Turbine Rating (kW): _____ Penstock Diameter (m): _____

Wind Turbine Model: Soma 1000 Controller Included (Y/N): Y
 Number Required: 1 Data Type (Annual/Monthly): Annual

Solar Panel Area (m²): Not Required Rating of Panel array (Wp): _____
 Optimised Panel Slope (°): _____

Storage & Network Battery Make: Trojan Inverter Make: Trace
 Battery Model: T105 Inverter Model: DR2424E
 Number Required: 104 Number Required: 6
 Days Storage Provided: 4 Length of Network Lines (km): 0

ECONOMICS

Total NPV (\$NZ): 91700 c/kWh produced: 161.4
 Total Capital Cost (\$NZ): 52701 Water Heating Included (Y/N): N
 Annual Cost to Community/Customer (NZ\$): 9340

Annual Cost of maintaining existing grid connection (NZ\$): 1823

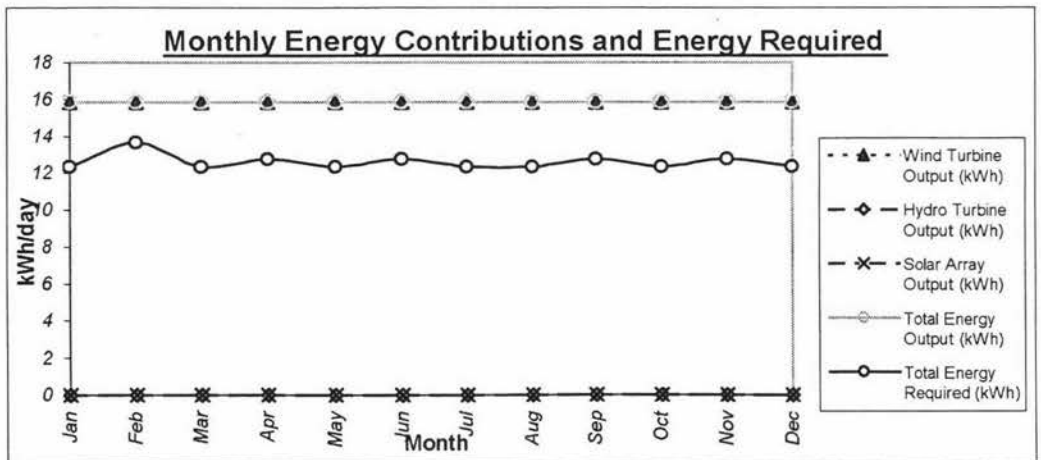

Scenario 8



Renewable Communities

Scenario Summary

Community / Client Name: D'Urville Island Contact Phone: _____
 Contact Person: _____ Contact E-mail: _____
 Contact Address: _____ Date: 9/05/00
 Type of Analysis: Individual Members

ENERGY RESOURCES AVAILABLE: Hydro Wind Solar

Hydro Type of Turbine: Pelton Penstock Length (m) 864
 Turbine Rating (kW): 5.43 Penstock Diameter (m): 0.079

Wind Turbine Model: Not Required Controller Included (Y/N): _____
 Number Required: _____ Data Type (Annual/Monthly): _____

Solar Panel Area (m²): Not Required Rating of Panel array (Wp): _____
 Optimised Panel Slope (°): _____

Storage & Network Battery Make: Not Required Inverter Make: Trace
 Battery Model: _____ Inverter Model: DR2424E
 Number Required: _____ Number Required: 3
 Days Storage Provided: _____ Length of Network Lines (km): 0

ECONOMICS

Total NPV (\$NZ): 58745 c/kWh produced: 12.6
 Total Capital Cost (\$NZ): 49938 Water Heating Included (Y/N): N
 Annual Cost to Community/Customer (NZ\$): 5983

Annual Cost of maintaining existing grid connection (NZ\$): 4761

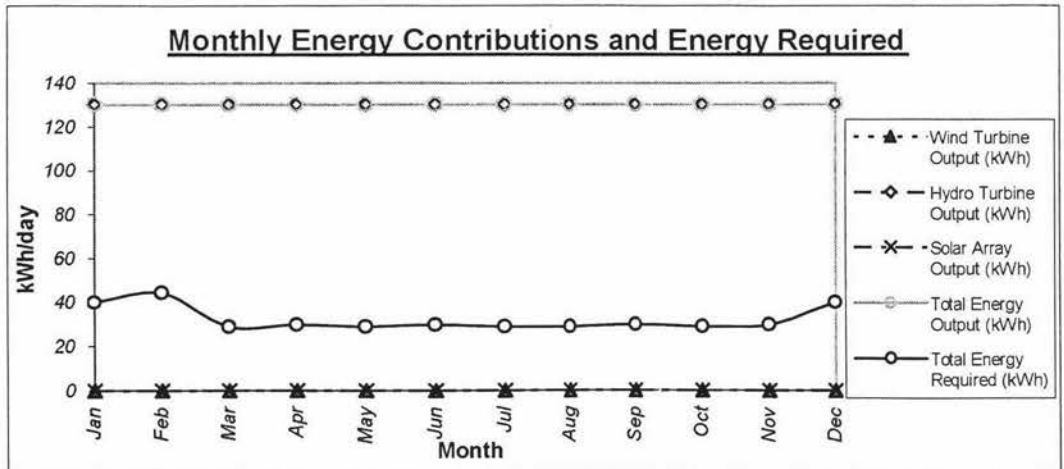

Scenario 9



Renewable Communities

Scenario Summary

Community / Client Name: D'Urville Island Contact Phone: _____
 Contact Person: _____ Contact E-mail: _____
 Contact Address: _____ Date: 9/05/00
 Type of Analysis: Individual Members

ENERGY RESOURCES AVAILABLE: Hydro Wind Solar

Hydro	Type of Turbine: <u>Pelton</u>	Penstock Length (m): <u>540</u>
	Turbine Rating (kW): <u>4.54</u>	Penstock Diameter (m): <u>0.085</u>
Wind	Turbine Model: <u>Not Required</u>	Controller Included (Y/N): _____
	Number Required: _____	Data Type (Annual/Monthly): _____
Solar	Panel Area (m ²): <u>Not Required</u>	Rating of Panel array (Wp): _____
	Optimised Panel Slope (°): _____	
Storage & Network	Battery Make: <u>Not Required</u>	Inverter Make: <u>Trace</u>
	Battery Model: _____	Inverter Model: <u>SW3024E</u>
	Number Required: _____	Number Required: <u>0</u>
	Days Storage Provided: _____	Length of Network Lines (km): <u>0</u>

ECONOMICS

Total NPV (\$NZ): 31467 c/kWh produced: 8.1
 Total Capital Cost (\$NZ): 25961 Water Heating Included (Y/N): Y
 Annual Cost to Community/Customer (NZ\$): 3205
 Annual Cost of maintaining existing grid connection (NZ\$): 2405

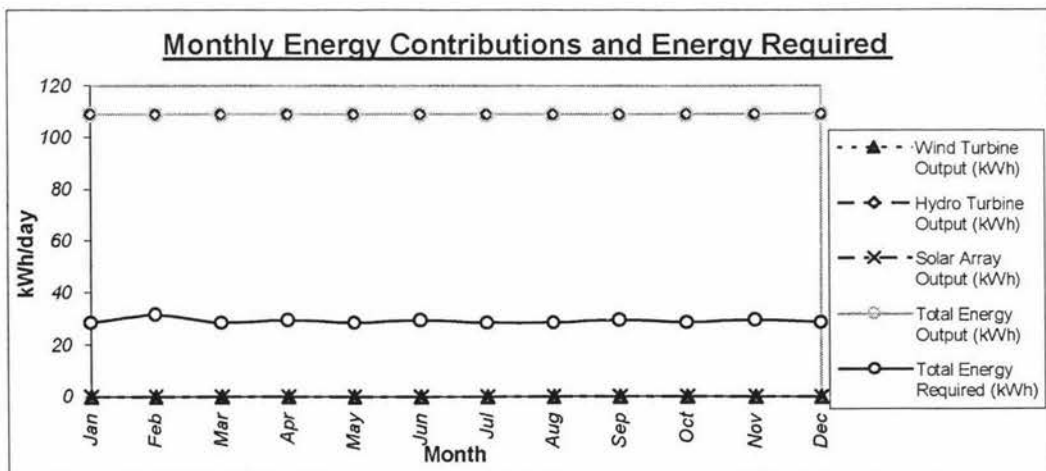

Scenario 10



Renewable Communities

Scenario Summary

Community / Client Name: D'Urville Island Contact Phone: _____
 Contact Person: _____ Contact E-mail: _____
 Contact Address: _____ Date: 9/05/00
 Type of Analysis: Individual Members

ENERGY RESOURCES AVAILABLE: Hydro Wind Solar

Hydro Type of Turbine: Pelton Penstock Length (m): 540
 Turbine Rating (kW): 4.54 Penstock Diameter (m): 0.085

Wind Turbine Model: Not Required Controller Included (Y/N): _____
 Number Required: _____ Data Type (Annual/Monthly): _____

Solar Panel Area (m²): Not Required Rating of Panel array (Wp): _____
 Optimised Panel Slope (°): _____

Storage & Network Battery Make: Not Required Inverter Make: Trace
 Battery Model: _____ Inverter Model: SW3024E
 Number Required: _____ Number Required: 0
 Days Storage Provided: _____ Length of Network Lines (km): 0

ECONOMICS

Total NPV (\$NZ): 31467 c/kWh produced: 8.1
 Total Capital Cost (\$NZ): 25961 Water Heating Included (Y/N): N
 Annual Cost to Community/Customer (NZ\$): 3205
 Annual Cost of maintaining existing grid connection (NZ\$): 1924

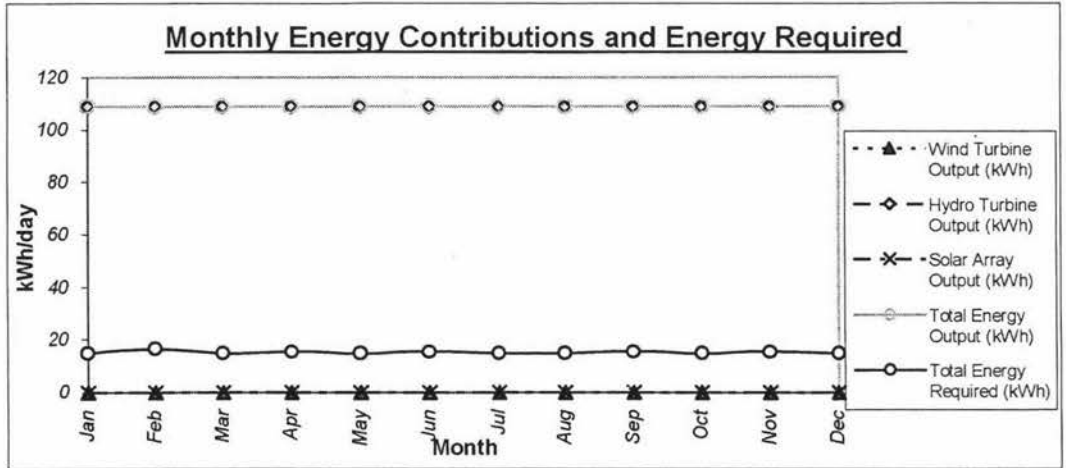

Scenario 11



Renewable Communities

Scenario Summary

Community / Client Name: <u>D'Urville Island</u>	Contact Phone: _____
Contact Person: _____	Contact E-mail: _____
Contact Address: _____	Date: <u>9/05/00</u>
Type of Analysis: <u>Individual Members</u>	

ENERGY RESOURCES AVAILABLE: Hydro Wind Solar

Hydro	Type of Turbine: <u>Pelton</u>	Penstock Length (m): <u>504</u>	
	Turbine Rating (kW): <u>8.10</u>	Penstock Diameter (m): <u>0.083</u>	
Wind	Turbine Model: <u>Not Required</u>	Controller Included (Y/N): _____	
	Number Required: _____	Data Type (Annual/Monthly): _____	
Solar	Panel Area (m ²): <u>Not Required</u>	Rating of Panel array (Wp): _____	
	Optimised Panel Slope (°): _____		
Storage & Network	Battery Make: <u>Not Required</u>	Inverter Make: <u>Trace</u>	
	Battery Model: _____	Inverter Model: <u>DR2424E</u>	
	Number Required: _____	Number Required: <u>4</u>	
	Days Storage Provided: _____	Length of Network Lines (km): <u>0</u>	

ECONOMICS

Total NPV (\$NZ): <u>55778</u>	c/kWh produced: <u>8.0</u>
Total Capital Cost (\$NZ): <u>47980</u>	Water Heating Included (Y/N): <u>Y</u>
Annual Cost to Community/Customer (NZ\$): <u>5681</u>	
Annual Cost of maintaining existing grid connection (NZ\$): <u>5945</u>	

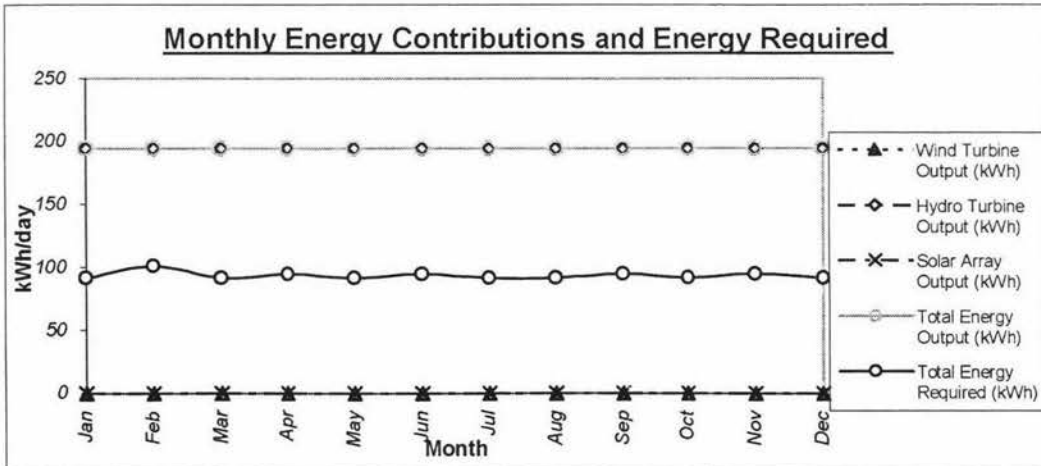

Scenario 12



Renewable Communities

Scenario Summary

Community / Client Name: D'Urville Island Contact Phone: _____
 Contact Person: _____ Contact E-mail: _____
 Contact Address: _____ Date: 9/05/00
 Type of Analysis: Individual Members

ENERGY RESOURCES AVAILABLE: Hydro Wind Solar

Hydro	Type of Turbine:	<u>Pelton</u>	Penstock Length (m)	<u>504</u>
	Turbine Rating (kW):	<u>8.10</u>	Penstock Diameter (m):	<u>0.083</u>
Wind	Turbine Model:	<u>Not Required</u>	Controller Included (Y/N):	_____
	Number Required:	_____	Data Type (Annual/Monthly)	_____
Solar	Panel Area (m ²):	<u>Not Required</u>	Rating of Panel array (Wp):	_____
	Optimised Panel Slope (°):	_____		
Storage & Network	Battery Make:	<u>Not Required</u>	Inverter Make:	<u>Trace</u>
	Battery Model:	_____	Inverter Model:	<u>DR2424E</u>
	Number Required:	_____	Number Required:	<u>3</u>
	Days Storage Provided:	_____	Length of Network Lines (km):	<u>0</u>

ECONOMICS

Total NPV (\$NZ): 52797 c/kWh produced: 7.6
 Total Capital Cost (\$NZ): 45030 Water Heating Included (Y/N): N
 Annual Cost to Community/Customer (NZ\$): 5377
 Annual Cost of maintaining existing grid connection (NZ\$): 5154

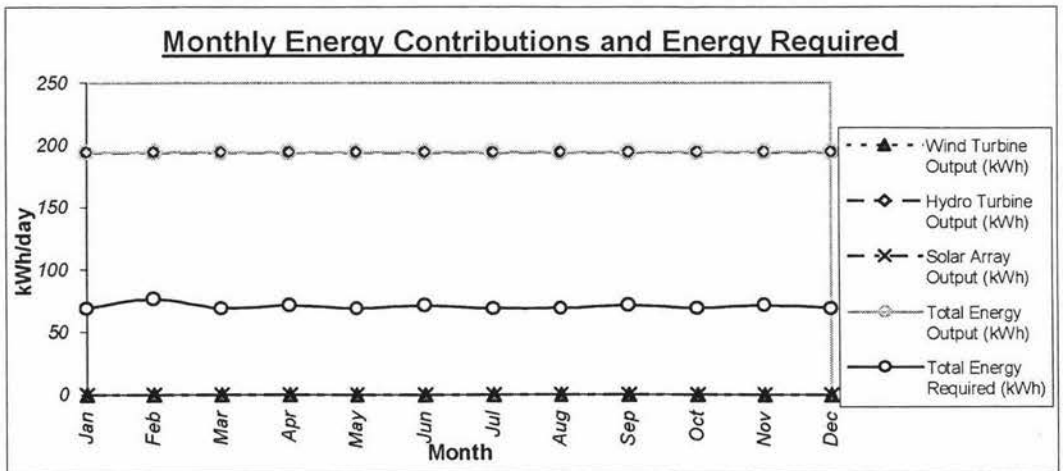

Scenario 13



Renewable Communities

Scenario Summary

Community / Client Name: <u>D'Urville Island</u>	Contact Phone: _____
Contact Person: _____	Contact E-mail: _____
Contact Address: _____	Date: <u>1/05/00</u>
Type of Analysis: <u>Individual Members</u>	

ENERGY RESOURCES AVAILABLE: Hydro Wind Solar

Hydro	Type of Turbine: <u>Not Available</u>	Penstock Length (m): _____	
	Turbine Rating (kW): _____	Penstock Diameter (m): _____	
Wind	Turbine Model: <u>Whisper 3000</u>	Controller Included (Y/N): <u>Y</u>	
	Number Required: <u>2</u>	Data Type (Annual/Monthly): <u>Annual</u>	
Solar	Panel Area (m ²): <u>Not Required</u>	Rating of Panel array (Wp): _____	
	Optimised Panel Slope (°): _____		
Storage & Network	Battery Make: <u>Trojan</u>	Inverter Make: <u>Trace</u>	
	Battery Model: <u>T105</u>	Inverter Model: <u>DR2424E</u>	
	Number Required: <u>440</u>	Number Required: <u>3</u>	
	Days Storage Provided: <u>4</u>	Length of Network Lines (km): <u>0</u>	

ECONOMICS

Total NPV (\$NZ): <u>302557</u>	¢/kWh produced: <u>101.5</u>
Total Capital Cost (\$NZ): <u>139863</u>	Water Heating Included (Y/N): <u>Y</u>
Annual Cost to Community/Customer (NZ\$): <u>30816</u>	
Annual Cost of maintaining existing grid connection (NZ\$): <u>5006</u>	

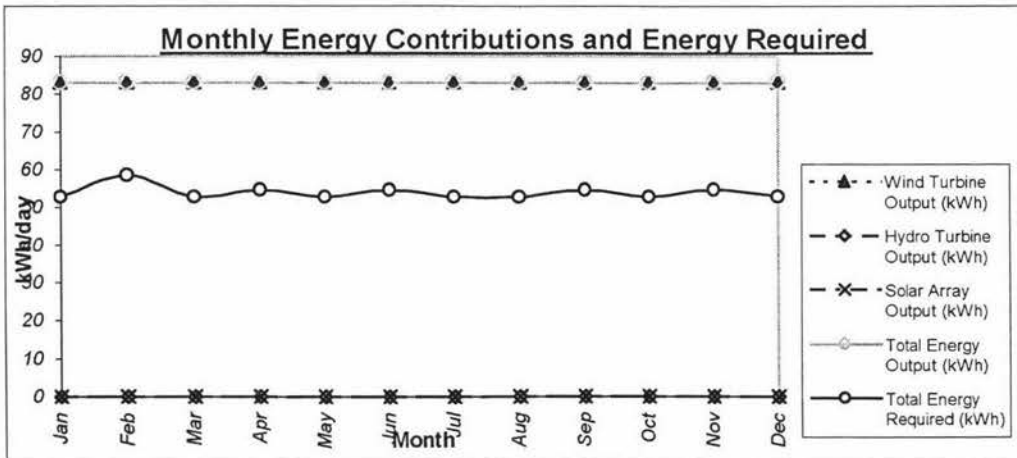

Scenario 14



Renewable Communities

Scenario Summary

Community / Client Name: D'Urville Island Contact Phone: _____
 Contact Person: _____ Contact E-mail: _____
 Contact Address: _____ Date: 1/05/00
 Type of Analysis: Individual Members

ENERGY RESOURCES AVAILABLE: Hydro Wind Solar

Hydro	Type of Turbine:	<u>Not Available</u>	Penstock Length (m):	_____
	Turbine Rating (kW):	_____	Penstock Diameter (m):	_____
Wind	Turbine Model:	<u>Whisper 3000</u>	Controller Included (Y/N):	<u>Y</u>
	Number Required:	<u>2</u>	Data Type (Annual/Monthly):	<u>Annual</u>
Solar	Panel Area (m ²):	<u>Not Required</u>	Rating of Panel array (Wp):	_____
	Optimised Panel Slope (°):	_____		
Storage & Network	Battery Make:	<u>Trojan</u>	Inverter Make:	<u>Trace</u>
	Battery Model:	<u>T105</u>	Inverter Model:	<u>DR2424E</u>
	Number Required:	<u>440</u>	Number Required:	<u>3</u>
	Days Storage Provided:	<u>4</u>	Length of Network Lines (km):	<u>0</u>

ECONOMICS

Total NPV (\$NZ): 302557 c/kWh produced: 101.5
 Total Capital Cost (\$NZ): 139863 Water Heating Included (Y/N): N
 Annual Cost to Community/Customer (NZ\$): 30816
 Annual Cost of maintaining existing grid connection (NZ\$): 4685

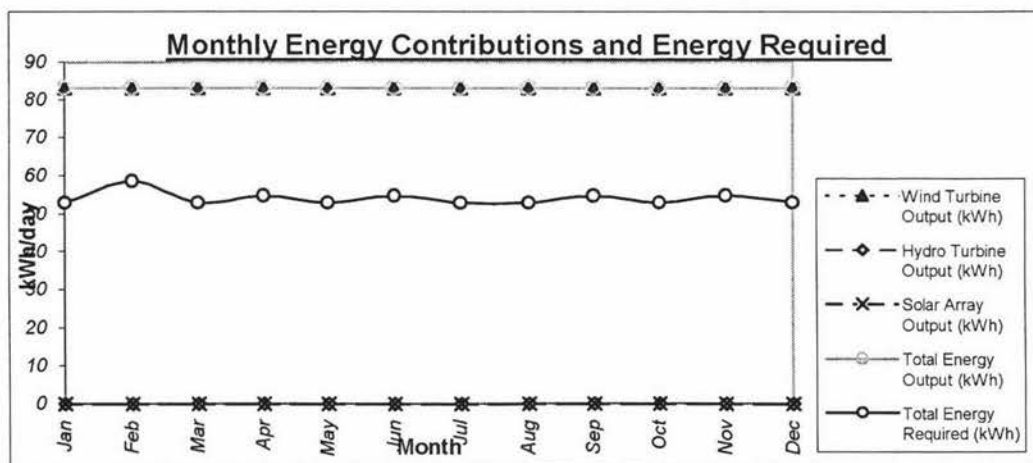

Scenario 15



Renewable Communities

Scenario Summary

Community / Client Name: D'Urville Island Contact Phone: _____
 Contact Person: _____ Contact E-mail: _____
 Contact Address: _____ Date: 1/05/00
 Type of Analysis: Individual Members

ENERGY RESOURCES AVAILABLE: Hydro Wind Solar

Hydro Type of Turbine: Not Available Penstock Length (m): _____
 Turbine Rating (kW): _____ Penstock Diameter (m): _____

Wind Turbine Model: Not Required Controller Included (Y/N): _____
 Number Required: _____ Data Type (Annual/Monthly): _____

Solar Panel Area (m²): 56.1 Rating of Panel array (Wp): 6127
 Optimised Panel Slope (°): 37

Storage & Network Battery Make: Trojan Inverter Make: Trace
 Battery Model: T105 Inverter Model: DR2424E
 Number Required: 252 Number Required: 3
 Days Storage Provided: 4 Length of Network Lines (km): 0

ECONOMICS

Total NPV (\$NZ): 228099 c/kWh produced: 520.8
 Total Capital Cost (\$NZ): 127464 Water Heating Included (Y/N): Y
 Annual Cost to Community/Customer (NZ\$): 23232
 Annual Cost of maintaining existing grid connection (NZ\$): 1624

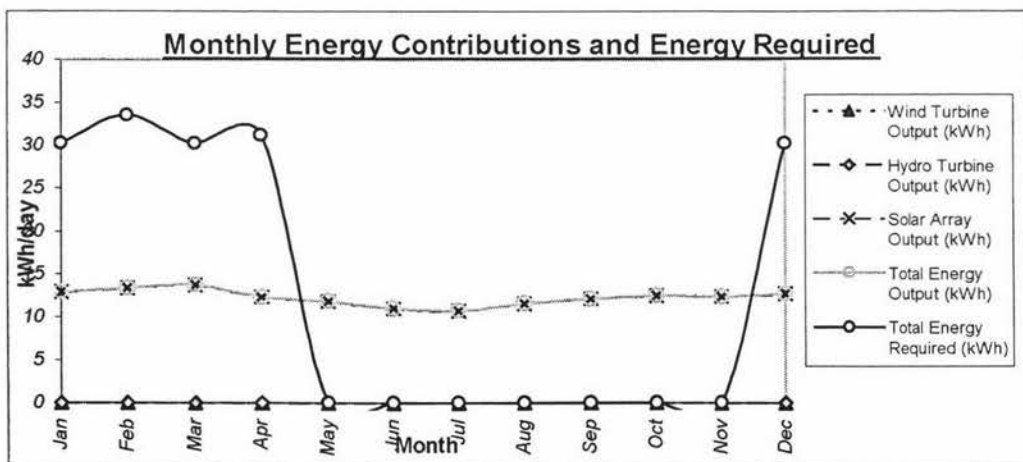

Scenario 16



Renewable Communities

Scenario Summary

Community / Client Name: D'Urville Island Contact Phone: _____
 Contact Person: _____ Contact E-mail: _____
 Contact Address: _____ Date: 1/05/00
 Type of Analysis: Individual Members

ENERGY RESOURCES AVAILABLE: Hydro Wind Solar

Hydro Type of Turbine: Not Available Penstock Length (m): _____
 Turbine Rating (kW): _____ Penstock Diameter (m): _____

Wind Turbine Model: Not Required Controller Included (Y/N): _____
 Number Required: _____ Data Type (Annual/Monthly): _____

Solar Panel Area (m²): 41.8 Rating of Panel array (Wp): 4566
 Optimised Panel Slope (°): 37

Storage & Network Battery Make: Trojan Inverter Make: Trace
 Battery Model: T105 Inverter Model: DR2424E
 Number Required: 188 Number Required: 2
 Days Storage Provided: 4 Length of Network Lines (km): 0

ECONOMICS

Total NPV (\$NZ): 169495 c/kWh produced: 519.2
 Total Capital Cost (\$NZ): 94416 Water Heating Included (Y/N): N
 Annual Cost to Community/Customer (NZ\$): 17263
 Annual Cost of maintaining existing grid connection (NZ\$): 1510

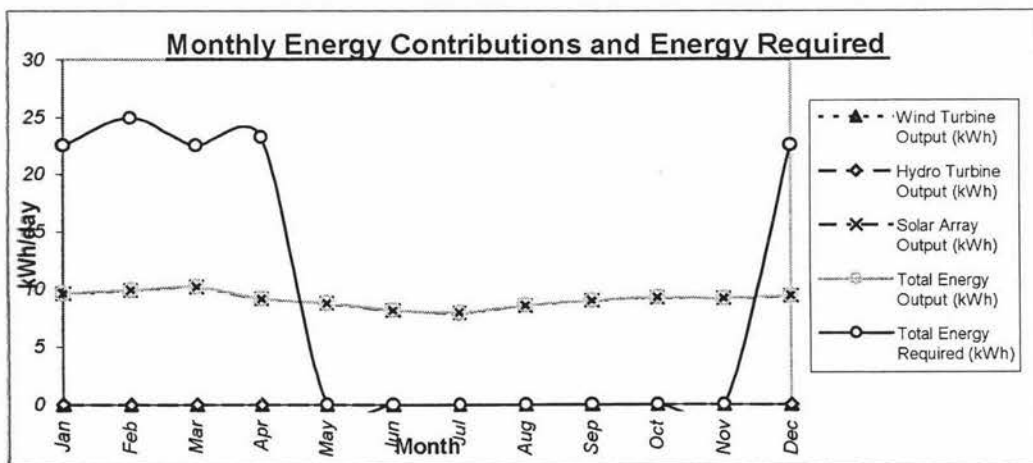

Scenario 17



Renewable Communities

Scenario Summary

Community / Client Name: D'Urville Island Contact Phone: _____
 Contact Person: _____ Contact E-mail: _____
 Contact Address: _____ Date: 1/05/00
 Type of Analysis: Individual Members

ENERGY RESOURCES AVAILABLE: Hydro Wind Solar

Hydro Type of Turbine: Not Available Penstock Length (m) _____
 Turbine Rating (kW): _____ Penstock Diameter (m): _____

Wind Turbine Model: Whisper 3000 Controller Included (Y/N): Y
 Number Required: 2 Data Type (Annual/Monthly): Annual

Solar Panel Area (m²): Not Required Rating of Panel array (Wp): _____
 Optimised Panel Slope (°): _____

Storage & Network Battery Make: Trojan Inverter Make: Trace
 Battery Model: T105 Inverter Model: DR2424E
 Number Required: 428 Number Required: 3
 Days Storage Provided: 4 Length of Network Lines (km): 0

ECONOMICS

Total NPV (\$NZ): 295192 c/kWh produced: 91.0
 Total Capital Cost (\$NZ): 136773 Water Heating Included (Y/N): Y
 Annual Cost to Community/Customer (NZ\$): 30066
 Annual Cost of maintaining existing grid connection (NZ\$): 3661

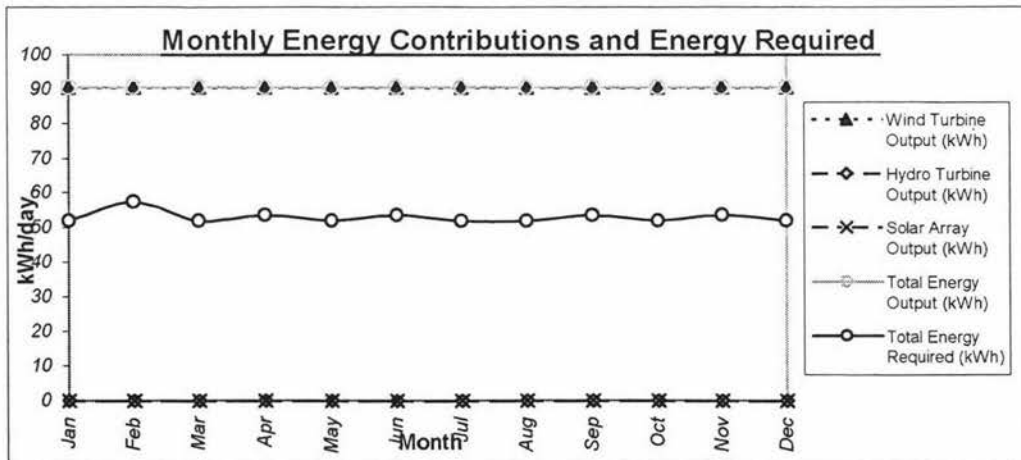

Scenario 18



Renewable Communities

Scenario Summary

Community / Client Name: D'Urville Island Contact Phone: _____
 Contact Person: _____ Contact E-mail: _____
 Contact Address: _____ Date: 1/05/00
 Type of Analysis: Individual Members

ENERGY RESOURCES AVAILABLE: Hydro Wind Solar

Hydro Type of Turbine: Not Available Penstock Length (m): _____
 Turbine Rating (kW): _____ Penstock Diameter (m): _____

Wind Turbine Model: Whisper 3000 Controller Included (Y/N): Y
 Number Required: 1 Data Type (Annual/Monthly): Annual

Solar Panel Area (m²): Not Required Rating of Panel array (Wp): _____
 Optimised Panel Slope (°): _____

Storage & Network Battery Make: Trojan Inverter Make: Trace
 Battery Model: T105 Inverter Model: DR2424E
 Number Required: 256 Number Required: 3
 Days Storage Provided: 4 Length of Network Lines (km): 0

ECONOMICS

Total NPV (\$NZ): 177863 c/kWh produced: 109.6
 Total Capital Cost (\$NZ): 84487 Water Heating Included (Y/N): N
 Annual Cost to Community/Customer (NZ\$): 18116
 Annual Cost of maintaining existing grid connection (NZ\$): 2910

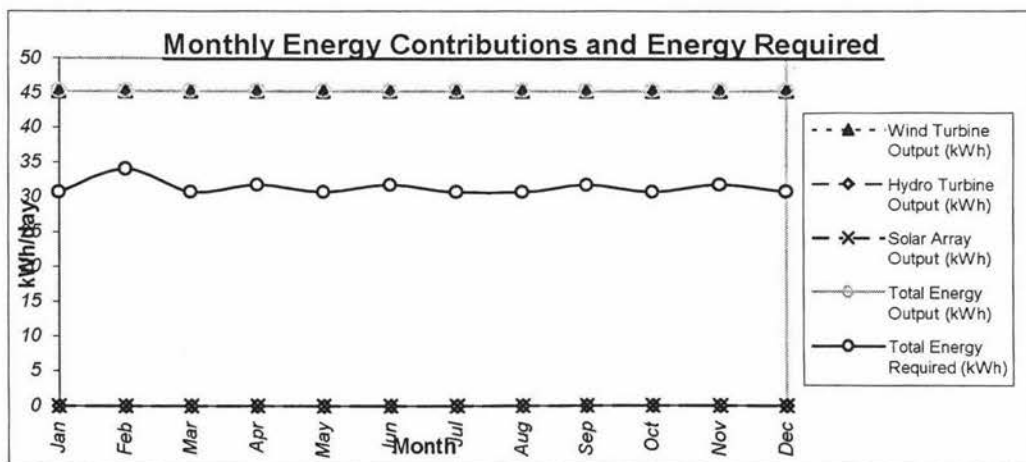

Scenario 19



Renewable Communities

Scenario Summary

Community / Client Name: D'Urville Island Contact Phone: _____
 Contact Person: _____ Contact E-mail: _____
 Contact Address: _____ Date: 1/05/00
 Type of Analysis: Individual Members

ENERGY RESOURCES AVAILABLE: Hydro Wind Solar

Hydro Type of Turbine: Not Available Penstock Length (m): _____
 Turbine Rating (kW): _____ Penstock Diameter (m): _____

Wind Turbine Model: Soma 1000 Controller Included (Y/N): Y
 Number Required: 1 Data Type (Annual/Monthly): Annual

Solar Panel Area (m²): Not Required Rating of Panel array (Wp): _____
 Optimised Panel Slope (°): _____

Storage & Network Battery Make: Trojan Inverter Make: Trace
 Battery Model: T105 Inverter Model: DR2424E
 Number Required: 124 Number Required: 3
 Days Storage Provided: 4 Length of Network Lines (km): 0

ECONOMICS

Total NPV (\$NZ): 95032 c/kWh produced: 156.3
 Total Capital Cost (\$NZ): 49001 Water Heating Included (Y/N): Y
 Annual Cost to Community/Customer (NZ\$): 9679
 Annual Cost of maintaining existing grid connection (NZ\$): 1113

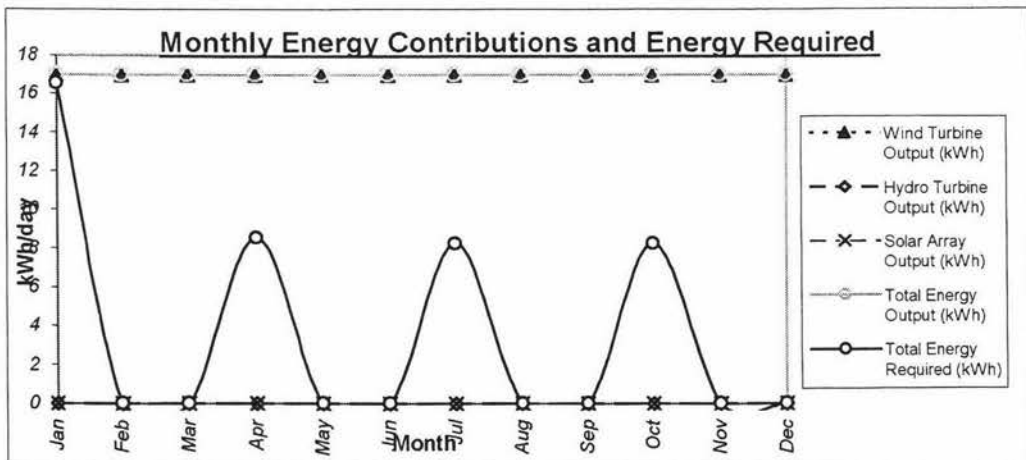

Scenario 20



Renewable Communities

Scenario Summary

Community / Client Name: D'Urville Island Contact Phone: _____
 Contact Person: _____ Contact E-mail: _____
 Contact Address: _____ Date: 1/05/00
 Type of Analysis: Individual Members

ENERGY RESOURCES AVAILABLE: Hydro Wind Solar

Hydro Type of Turbine: Not Available Penstock Length (m): _____
 Turbine Rating (kW): _____ Penstock Diameter (m): _____

Wind Turbine Model: Soma 1000 Controller Included (Y/N): Y
 Number Required: 1 Data Type (Annual/Monthly): Annual

Solar Panel Area (m²): Not Required Rating of Panel array (Wp): _____
 Optimised Panel Slope (°): _____

Storage & Network Battery Make: Trojan Inverter Make: Trace
 Battery Model: T105 Inverter Model: DR2424E
 Number Required: 68 Number Required: 2
 Days Storage Provided: 4 Length of Network Lines (km): 0

ECONOMICS

Total NPV (SNZ): 57680 c/kWh produced: 94.9
 Total Capital Cost (SNZ): 31631 Water Heating Included (Y/N): N
 Annual Cost to Community/Customer (NZ\$): 5875

Annual Cost of maintaining existing grid connection (NZ\$): 1053

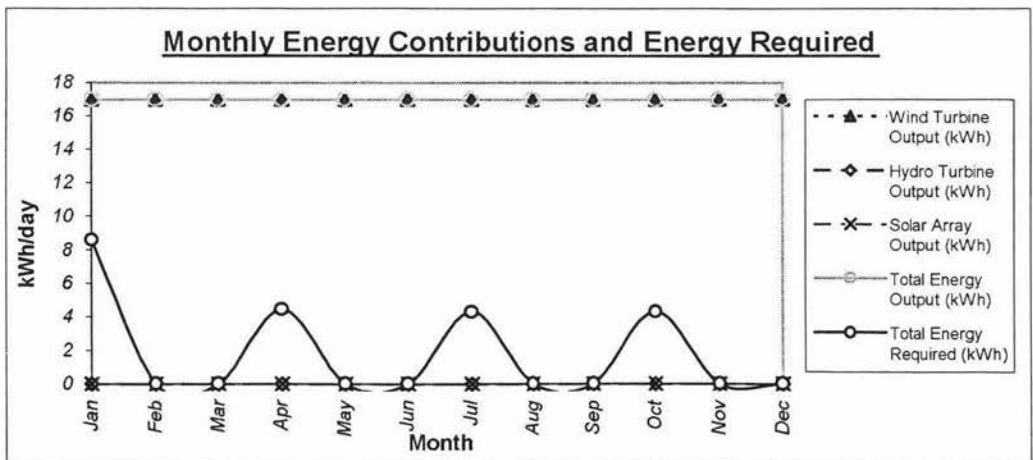

Scenario 21



Renewable Communities

Scenario Summary

Community / Client Name: D'Urville Island Contact Phone: _____
 Contact Person: _____ Contact E-mail: _____
 Contact Address: _____ Date: 1/05/00
 Type of Analysis: Individual Members

ENERGY RESOURCES AVAILABLE: Hydro Wind Solar

Hydro Type of Turbine: Not Available Penstock Length (m): _____
 Turbine Rating (kW): _____ Penstock Diameter (m): _____

Wind Turbine Model: Whisper 3000 Controller Included (Y/N): Y
 Number Required: 1 Data Type (Annual/Monthly): Annual

Solar Panel Area (m²): Not Required Rating of Panel array (Wp): _____
 Optimised Panel Slope (°): _____

Storage & Network Battery Make: Trojan Inverter Make: Trace
 Battery Model: T105 Inverter Model: DR2424E
 Number Required: 180 Number Required: 5
 Days Storage Provided: 4 Length of Network Lines (km): 0

ECONOMICS

Total NPV (\$NZ): 137179 c/kWh produced: 92.1
 Total Capital Cost (\$NZ): 70817 Water Heating Included (Y/N): Y
 Annual Cost to Community/Customer (NZ\$): 13972
 Annual Cost of maintaining existing grid connection (NZ\$): 2031

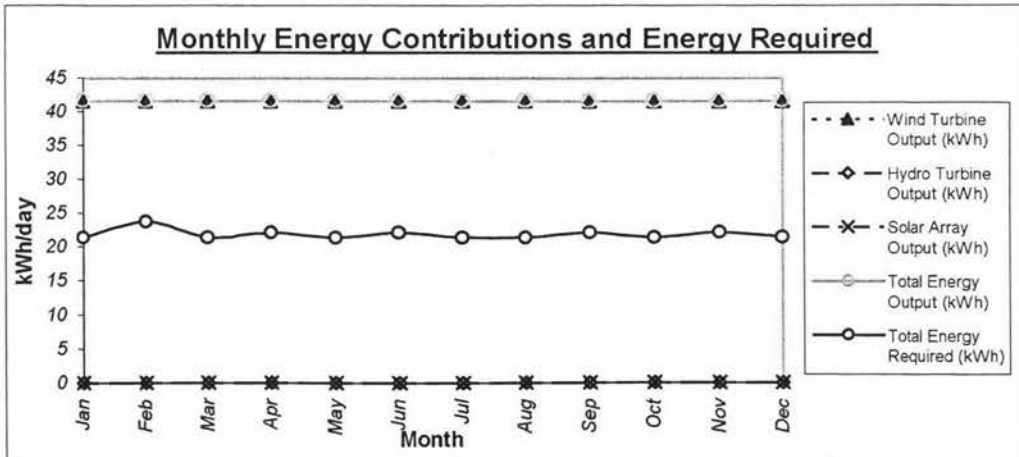

Scenario 22



Renewable Communities

Scenario Summary

Community / Client Name: D'Urville Island Contact Phone: _____
 Contact Person: _____ Contact E-mail: _____
 Contact Address: _____ Date: 1/05/00
 Type of Analysis: Individual Members

ENERGY RESOURCES AVAILABLE: Hydro Wind Solar

Hydro Type of Turbine: Not Available Penstock Length (m): _____
 Turbine Rating (kW): _____ Penstock Diameter (m): _____

Wind Turbine Model: Soma 1000 Controller Included (Y/N): Y
 Number Required: 1 Data Type (Annual/Monthly): Annual

Solar Panel Area (m²): Not Required Rating of Panel array (Wp): _____
 Optimised Panel Slope (°): _____

Storage & Network Battery Make: Trojan Inverter Make: Trace
 Battery Model: T105 Inverter Model: DR2424E
 Number Required: 88 Number Required: 5
 Days Storage Provided: 4 Length of Network Lines (km): 0

ECONOMICS

Total NPV (\$NZ): 78899 c/kWh produced: 138.8
 Total Capital Cost (\$NZ): 45631 Water Heating Included (Y/N): N
 Annual Cost to Community/Customer (NZ\$): 8036

Annual Cost of maintaining existing grid connection (NZ\$): 1637

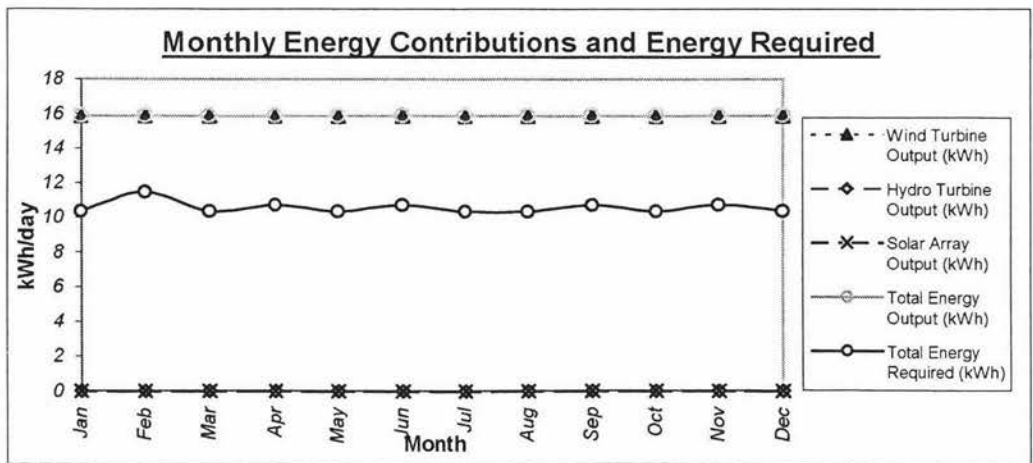

Scenario 23



Renewable Communities

Scenario Summary

Community / Client Name: D'Urville Island Contact Phone: _____
 Contact Person: _____ Contact E-mail: _____
 Contact Address: _____ Date: 7/05/00
 Type of Analysis: Individual Members

ENERGY RESOURCES AVAILABLE: Hydro Wind Solar

Hydro Type of Turbine: Not Available Penstock Length (m): _____
 Turbine Rating (kW): _____ Penstock Diameter (m): _____

Wind Turbine Model: Whisper 3000 Controller Included (Y/N): Y
 Number Required: 2 Data Type (Annual/Monthly): Annual

Solar Panel Area (m²): Not Required Rating of Panel array (Wp): _____
 Optimised Panel Slope (°): _____

Storage & Network Battery Make: Trojan Inverter Make: Trace
 Battery Model: T105 Inverter Model: DR2424E
 Number Required: 552 Number Required: 7
 Days Storage Provided: 4 Length of Network Lines (km): 8.5

ECONOMICS

Total NPV (SNZ): 607303 c/kWh produced: 203.8
 Total Capital Cost (SNZ): 350503 Water Heating Included (Y/N): Y
 Annual Cost to Community/Customer (NZ\$): 61855
 Annual Cost of maintaining existing grid connection (NZ\$): 6513

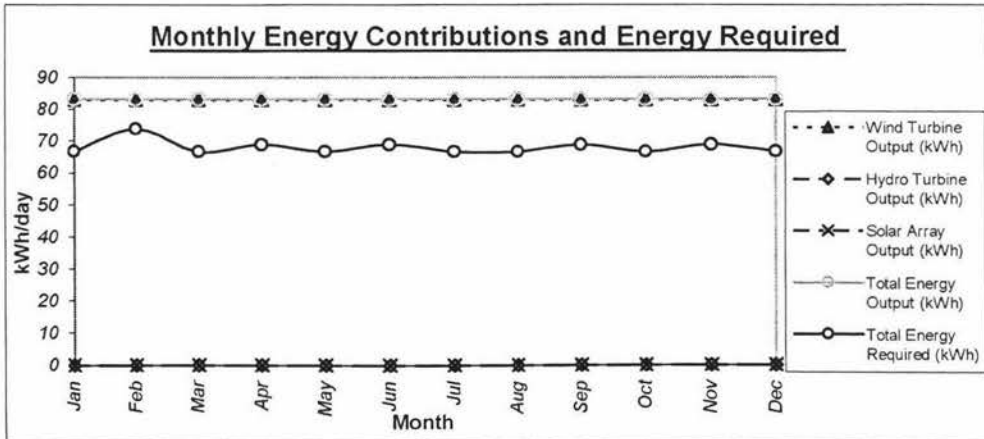

Scenario 24



Renewable Communities

Scenario Summary

Community / Client Name: D'Urville Island Contact Phone: _____
 Contact Person: _____ Contact E-mail: _____
 Contact Address: _____ Date: 7/05/00
 Type of Analysis: Individual Members

ENERGY RESOURCES AVAILABLE: Hydro Wind Solar

Hydro Type of Turbine: Not Available Penstock Length (m): _____
 Turbine Rating (kW): _____ Penstock Diameter (m): _____

Wind Turbine Model: Whisper 3000 Controller Included (Y/N): Y
 Number Required: 2 Data Type (Annual/Monthly): Annual

Solar Panel Area (m²): Not Required Rating of Panel array (Wp): _____
 Optimised Panel Slope (°): _____

Storage & Network Battery Make: Trojan Inverter Make: Trace
 Battery Model: T105 Inverter Model: DR2424E
 Number Required: 340 Number Required: 7
 Days Storage Provided: 4 Length of Network Lines (km): 8.5

ECONOMICS

Total NPV (SNZ): 477184 c/kWh produced: 160.1
 Total Capital Cost (SNZ): 295913 Water Heating Included (Y/N): N
 Annual Cost to Community/Customer (NZ\$): 48602
 Annual Cost of maintaining existing grid connection (NZ\$): 5592

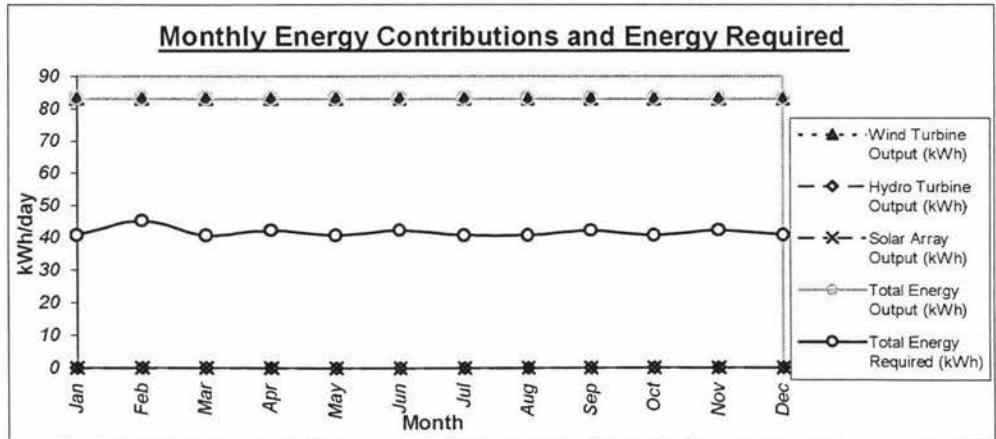

Scenario 25



Renewable Communities

Scenario Summary

Community / Client Name: D'Urville Island Contact Phone: _____
 Contact Person: _____ Contact E-mail: _____
 Contact Address: _____ Date: 7/05/00
 Type of Analysis: Individual Members

ENERGY RESOURCES AVAILABLE: Hydro Wind Solar

Hydro	Type of Turbine:	<u>Pelton</u>	Penstock Length (m)	<u>1404</u>
	Turbine Rating (kW):	<u>9.98</u>	Penstock Diameter (m):	<u>0.111</u>
Wind	Turbine Model:	<u>Not Required</u>	Controller Included (Y/N):	_____
	Number Required:	_____	Data Type (Annual/Monthly):	_____
Solar	Panel Area (m ²):	<u>Not Required</u>	Rating of Panel array (Wp):	_____
	Optimised Panel Slope (°):	_____		
Storage & Network	Battery Make:	<u>Not Required</u>	Inverter Make:	<u>Trace</u>
	Battery Model:	_____	Inverter Model:	<u>DR2424E</u>
	Number Required:	_____	Number Required:	<u>4</u>
	Days Storage Provided:	_____	Length of Network Lines (km):	<u>14.5</u>

ECONOMICS

Total NPV (\$NZ): 479869 c/kWh produced: 55.9
 Total Capital Cost (\$NZ): 372499 Water Heating Included (Y/N): Y
 Annual Cost to Community/Customer (NZ\$): 48876
 Annual Cost of maintaining existing grid connection (NZ\$): 10425

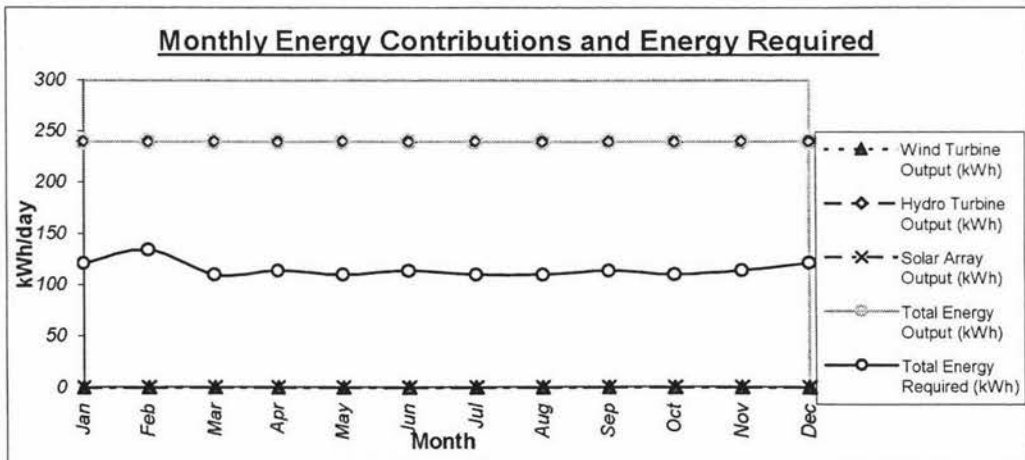

Scenario 26



Renewable Communities

Scenario Summary

Community / Client Name: D'Urville Island Contact Phone: _____
 Contact Person: _____ Contact E-mail: _____
 Contact Address: _____ Date: 7/05/00
 Type of Analysis: Individual Members

ENERGY RESOURCES AVAILABLE: Hydro Wind Solar

Hydro Type of Turbine: Pelton Penstock Length (m): 1404
 Turbine Rating (kW): 9.98 Penstock Diameter (m): 0.111

Wind Turbine Model: Not Required Controller Included (Y/N): _____
 Number Required: _____ Data Type (Annual/Monthly): _____

Solar Panel Area (m²): Not Required Rating of Panel array (Wp): _____
 Optimised Panel Slope (°): _____

Storage & Network Battery Make: Not Required Inverter Make: Trace
 Battery Model: _____ Inverter Model: DR2424E
 Number Required: _____ Number Required: 3
 Days Storage Provided: _____ Length of Network Lines (km): 14.5

ECONOMICS

Total NPV (\$NZ): 476887 c/kWh produced: 55.6
 Total Capital Cost (\$NZ): 369549 Water Heating Included (Y/N): N
 Annual Cost to Community/Customer (NZ\$): 48572
 Annual Cost of maintaining existing grid connection (NZ\$): 8508

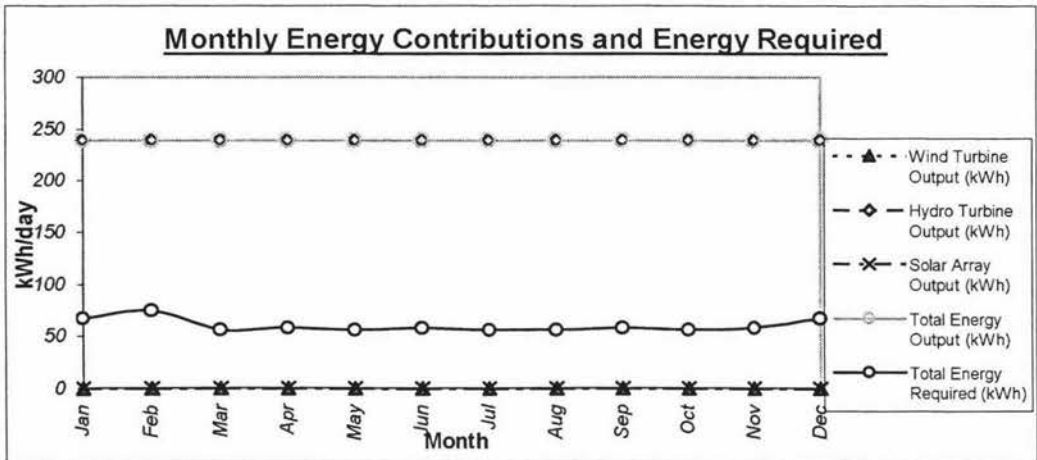

Scenario 29



Renewable Communities

Scenario Summary

Community / Client Name: D'Urville Island Contact Phone: _____
 Contact Person: _____ Contact E-mail: _____
 Contact Address: _____ Date: 7/05/00
 Type of Analysis: Individual Members

ENERGY RESOURCES AVAILABLE: Hydro Wind Solar

Hydro Type of Turbine: Pelton Penstock Length (m) 672
 Turbine Rating (kW): 8.10 Penstock Diameter (m): 0.088

Wind Turbine Model: Not Required Controller Included (Y/N): _____
 Number Required: _____ Data Type (Annual/Monthly): _____

Solar Panel Area (m²): Not Required Rating of Panel array (Wp): _____
 Optimised Panel Slope (°): _____

Storage & Network Battery Make: Not Required Inverter Make: Trace
 Battery Model: _____ Inverter Model: DR2424E
 Number Required: _____ Number Required: 6
 Days Storage Provided: _____ Length of Network Lines (km): 2.75

ECONOMICS

Total NPV (\$NZ): 134236 c/kWh produced: 19.3
 Total Capital Cost (\$NZ): 108880 Water Heating Included (Y/N): Y
 Annual Cost to Community/Customer (NZ\$): 13672

Annual Cost of maintaining existing grid connection (NZ\$): 12575

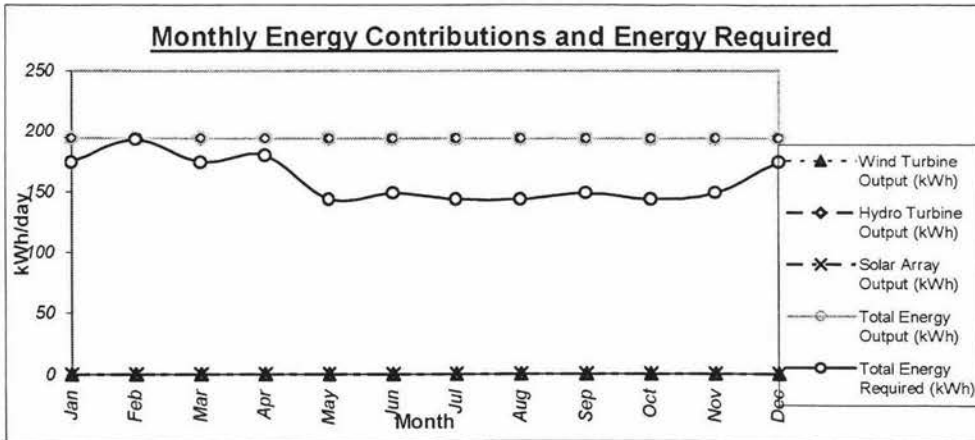



Renewable Communities

Scenario Summary

Community / Client Name: D'Urville Island Contact Phone: _____
 Contact Person: _____ Contact E-mail: _____
 Contact Address: _____ Date: 7/05/00
 Type of Analysis: Individual Members

ENERGY RESOURCES AVAILABLE: Hydro Wind Solar

Hydro	Type of Turbine: <u>Pelton</u>	Penstock Length (m): <u>672</u>
	Turbine Rating (kW): <u>8.10</u>	Penstock Diameter (m): <u>0.088</u>
Wind	Turbine Model: <u>Not Required</u>	Controller Included (Y/N): _____
	Number Required: _____	Data Type (Annual/Monthly): _____
Solar	Panel Area (m ²): <u>Not Required</u>	Rating of Panel array (Wp): _____
	Optimised Panel Slope (°): _____	
Storage & Network	Battery Make: <u>Not Required</u>	Inverter Make: <u>Trace</u>
	Battery Model: _____	Inverter Model: <u>DR2424E</u>
	Number Required: _____	Number Required: <u>5</u>
	Days Storage Provided: _____	Length of Network Lines (km): <u>2.75</u>

ECONOMICS

Total NPV (\$NZ): 131255 c/kWh produced: 18.8
 Total Capital Cost (\$NZ): 105930 Water Heating Included (Y/N): N
 Annual Cost to Community/Customer (NZ\$): 13369
 Annual Cost of maintaining existing grid connection (NZ\$): 11349

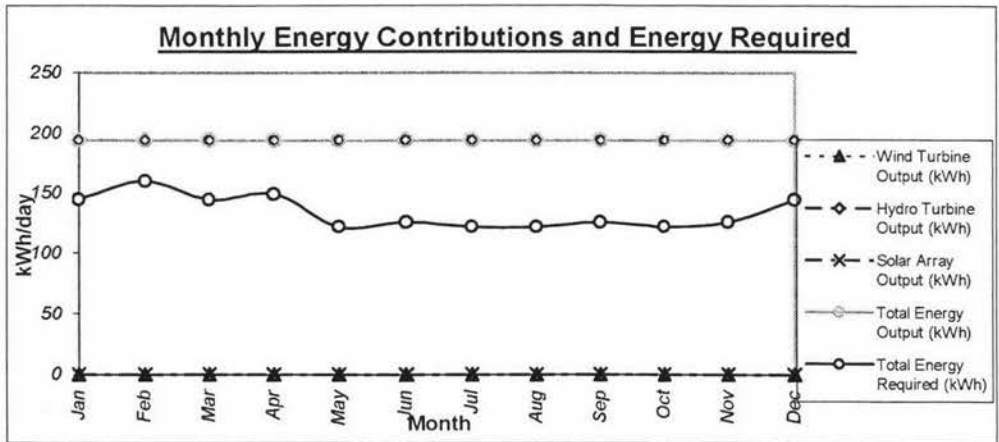

Scenario 31



Renewable Communities

Scenario Summary

Community / Client Name: D'Urville Island Contact Phone: _____
 Contact Person: _____ Contact E-mail: _____
 Contact Address: _____ Date: 7/05/00
 Type of Analysis: Individual Members

ENERGY RESOURCES AVAILABLE: Hydro Wind Solar

Hydro Type of Turbine: Pelton Penstock Length (m): 864
 Turbine Rating (kW): 5.43 Penstock Diameter (m): 0.079

Wind Turbine Model: Not Required Controller Included (Y/N): _____
 Number Required: _____ Data Type (Annual/Monthly): _____

Solar Panel Area (m²): Not Required Rating of Panel array (Wp): _____
 Optimised Panel Slope (°): _____

Storage & Network Battery Make: Not Required Inverter Make: Trace
 Battery Model: _____ Inverter Model: DR2424E
 Number Required: _____ Number Required: 5
 Days Storage Provided: _____ Length of Network Lines (km): 8.6

ECONOMICS

Total NPV (SNZ): 281665 c/kWh produced: 60.3
 Total Capital Cost (SNZ): 219788 Water Heating Included (Y/N): Y
 Annual Cost to Community/Customer (NZ\$): 28688
 Annual Cost of maintaining existing grid connection (NZ\$): 6805

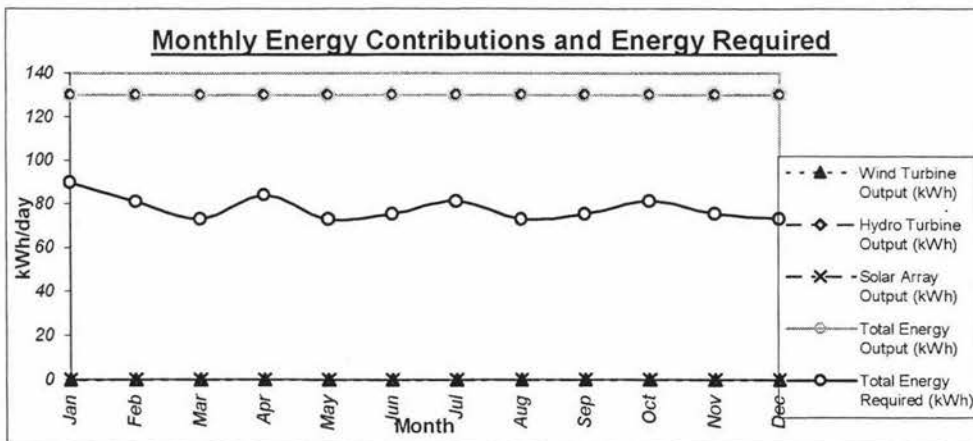



Renewable Communities

Scenario Summary

Community / Client Name: D'Urville Island Contact Phone: _____
 Contact Person: _____ Contact E-mail: _____
 Contact Address: _____ Date: 7/05/00
 Type of Analysis: Individual Members

ENERGY RESOURCES AVAILABLE: Hydro Wind Solar

Hydro Type of Turbine: Pelton Penstock Length (m): 864
 Turbine Rating (kW): 5.43 Penstock Diameter (m): 0.079

Wind Turbine Model: Not Required Controller Included (Y/N): _____
 Number Required: _____ Data Type (Annual/Monthly): _____

Solar Panel Area (m²): Not Required Rating of Panel array (Wp): _____
 Optimised Panel Slope (°): _____

Storage & Network Battery Make: Not Required Inverter Make: Trace
 Battery Model: _____ Inverter Model: DR2424E
 Number Required: _____ Number Required: 4
 Days Storage Provided: _____ Length of Network Lines (km): 8.6

ECONOMICS

Total NPV (\$NZ): 278684 c/kWh produced: 59.7
 Total Capital Cost (\$NZ): 216838 Water Heating Included (Y/N): N
 Annual Cost to Community/Customer (NZ\$): 28385
 Annual Cost of maintaining existing grid connection (NZ\$): 5600

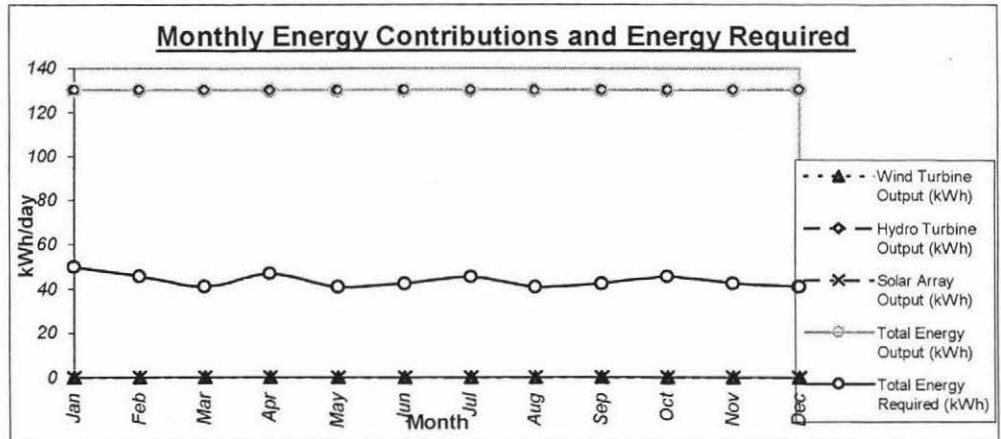

Scenario 33



Renewable Communities

Scenario Summary

Community / Client Name: D'Urville Island Contact Phone: _____
 Contact Person: _____ Contact E-mail: _____
 Contact Address: _____ Date: 7/05/00
 Type of Analysis: Individual Members

ENERGY RESOURCES AVAILABLE: Hydro Wind Solar

Hydro Type of Turbine: Pelton Penstock Length (m): 1350
 Turbine Rating (kW): 34.02 Penstock Diameter (m): 0.174

Wind Turbine Model: Not Required Controller Included (Y/N): _____
 Number Required: _____ Data Type (Annual/Monthly): _____

Solar Panel Area (m²): Not Required Rating of Panel array (Wp): _____
 Optimised Panel Slope (°): _____

Storage & Network Battery Make: Not Required Inverter Make: _____
 Battery Model: _____ Inverter Model: _____
 Number Required: _____ Number Required: 0
 Days Storage Provided: _____ Length of Network Lines (km): 0

ECONOMICS

Total NPV (\$NZ): 166540 c/kWh produced: 5.7
 Total Capital Cost (\$NZ): 137401 Water Heating Included (Y/N): Y
 Annual Cost to Community/Customer (NZ\$): 16962
 Annual Cost of maintaining existing grid connection (NZ\$): 36318

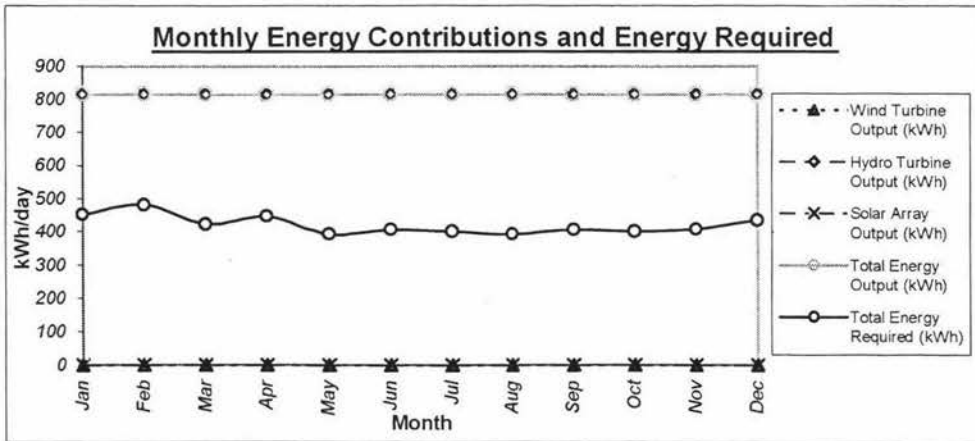

Scenario 34



Renewable Communities

Scenario Summary

Community / Client Name: D'Urville Island Contact Phone: _____
 Contact Person: _____ Contact E-mail: _____
 Contact Address: _____ Date: 7/05/00
 Type of Analysis: Individual Members

ENERGY RESOURCES AVAILABLE: Hydro Wind Solar

Hydro Type of Turbine: Not Available Penstock Length (m): _____
 Turbine Rating (kW): _____ Penstock Diameter (m): _____

Wind Turbine Model: Jacobs 29-20 Controller Included (Y/N): Y
 Number Required: 2 Data Type (Annual/Monthly): Annual

Solar Panel Area (m²): 5.5 Rating of Panel array (Wp): 602
 Optimised Panel Slope (°): 37

Storage & Network Battery Make: Not Required Inverter Make: Trace
 Battery Model: _____ Inverter Model: SW3024E
 Number Required: _____ Number Required: 0
 Days Storage Provided: _____ Length of Network Lines (km): 0

ECONOMICS

Total NPV (\$NZ): 123932 c/kWh produced: 7.4
 Total Capital Cost (\$NZ): 88152 Water Heating Included (Y/N): Y
 Annual Cost to Community/Customer (NZ\$): 12623
 Annual Cost of maintaining existing grid connection (NZ\$): 36318

