

Copyright is owned by the Author of the thesis. Permission is given for a copy to be downloaded by an individual for the purpose of research and private study only. The thesis may not be reproduced elsewhere without the permission of the Author.

The new costume designer:

An exploration of digital and physical technologies for costume development in the film industry.

An exegesis presented in partial fulfillment of the
requirements for the degree of Master of Design

Massey University, College of Creative Arts
Wellington, New Zealand

Jessica Lewis
July 2019

Table of contents

5	Abstract
7	Acknowledgements
9-10	Intro
12-13	How technology has changed costume making for film
14	Accuracy between physical and digital garments for authentic outcomes
16-17	Film industry roles and processes with technology: Interviews
18-19	Patternmaking methods and systems
20	Physical and digital methods of making
20	Mannequins, live fit models and avatars
20-24	3D simulation for design and fit of garments
23	Case study: Pogo, The Umbrella Academy (Tv Show, 2019)
25	Case study: Alita, Alita Battle Angel (Film, 2019)
27	Methods
28-29	Schema
30-33	Storyline and character development: koloss
34	Avatar and mannequin development:
34-39	Avatars for digital work
40-41	Mannequins for physical work
43	Costume design development:
44	Creating a one size fits all uniform
46	Fabrics
48-63	Pattern developments and toiles
64-65	Final garments
66-67	Reflections
68-69	Bibliography
70-72	List of figures
73-86	Appendices

Abstract

Three-dimensional (3D) simulation software is utilised for digital visualization of garment design, pattern development, drape, and fit on virtual models and avatars within the costume and fashion industries. This practice-led project explores the use of digital design technologies for costumes created in a digital space and asks “How do current digital and physical technologies work as integrated practice within the industry of costume design for film?” From a fashion perspective, many researchers have looked into how historical costumes can be reproduced as accurate 3D models or how 3D modelling software can be used for prototyping and fit for production efficiency. However, there is little published academic research discussing the use of digital technologies by costume designers for physical costume design and development in the film industry. Initial research for this project included interviews with experts from physical costume design departments in the film industry to gain insight as to the extent and relevance of collaborative work experiences using both physical and digital processes, systems and technologies within their practice.

Through an original creative project using an iterative design process, this research project focuses on the generation of physical costume concepts for a fantasy creature. These costumes are designed to tailor to the exaggerated humanoid body of the “koloss” character from Brandon Sanderson’s *Mistborn: Era 1* series as he morphs from a child to an adult. This project explores how patternmaking and 3D cloth simulation software can be applied to costume generation that navigates the physical and virtual world. Digital and physical visual, patternmaking, and sampling tools are utilised with tacit knowledge of an experienced technical fashion designer to explore how physical costume designers can feel empowered in the creative process when working between physical and digital departments.

Keywords: digital technologies, costume design, fantasy, patternmaking, 3D simulation, Computer Aided Design (CAD), digital workspace, computer-generated imagery (CGI).

Acknowledgements

I would like to thank many people who have supported me throughout this project and for whom I will be forever grateful for:

The School of Design at Massey University, Wellington for the generous funding that gave me the opportunity to undertake this Masters project. My supervisors Deb Cumming and Tanya Marriott for always challenging me, giving me new perspectives on design and making, and always being generous in our meetings with both time and knowledge.

The film industry experts for their enthusiasm to share with me their experiences in the industry and giving feedback on my project. Cameron Doidge for his work on the avatars, Cameron Holder for his work on the mannequins, and Uli Thie for kindly making the mannequin stands.

The School of Design staff, especially the fashion and technical staff, for always being an ear to listen, offering help and feedback, and encouraging me throughout this journey. Carol Stevenson and Brent Davenport for the extra support when I needed a work/study balance.

Finally, thank you to my friends and Masters crew for chatting and keeping me sane. My family Shane, Sonya, Louis, Rachel and Nathaniel for always encouraging me to follow my passions and being proud of what I achieve, and Mark for always keeping me laughing and supporting me through the ups and downs of this project over the last two years.

Thank you.

Intro

My Honours Fashion Design graduate collection had a focus on tailored fashion garments based on costumes for a live-action film adaptation of *The Tales of Beatrix Potter*. This aided my passion for costume design, tailoring, the use of computer aided design (CAD), and working between digital and physical making processes. Since finishing my Honours degree in 2012, I have worked at Massey University which allowed me to refine my skills in CAD software and hardware for fashion design and making. Throughout working in the Fashion department at Massey University, I have had the opportunity to connect with people in the fashion industry and academia who have an interest in, and are experimenting with, digital technologies. These discussions provided me with an understanding around the processes they use to design and create garments in digital workspaces and led me to think about how I could utilise CAD and 3D simulation software for designing physical costumes. As a continuation of these discussions, I have connected with costume design and production experts from the film industry to gain insight into the processes, methods and technologies they are currently using for designing and making costumes for live-action and motion-capture animation films. Talking to these experts validated the placement of this project within the current New Zealand film industry and confirmed that digital animation departments, who create digital costumes for digital characters, are more frequently engaging with physical costume departments to achieve more realistic results in computer-generated costumes. Digital Creature, Character Artists (DCCA) are shifting their thinking away from seeing garments as a 3D object and are starting to understand that it is a 2D flat pattern shape that creates the 3D shape (Interviewee C, 2019).

The 'new' physical costume designer is a designer and maker that has an understanding of traditional garment making techniques but can see the importance and has the competence to work in digital workspaces. The ability to work between physical and digital methods of making can empower the costume designer and allows for streamlined workflow between costume and animation departments (Interviewee C, 2019). Being able to work in a digital workspace allows for most changes to be made quickly and also allows makers to go back and forth between different versions, with the possibility of easily combining them together. This project contributes to the currently limited academic research that discusses digital technologies for physical costume design development and making in the film industry. This practice-based research explores the expanding role of the costume designer for film, the changing relationship between physical and digital methods of design and making for costume in the

film industry and the future applications of these methods.

The design case study for this project explores creating a 'one size fits all' military uniform for my interpretation of Brandon Sanderson's koloss character from the fantasy book series *Mistborn: Era 1*. Using a pre-established character allowed me to focus on costume development and gave me grounding for decisions made throughout the process. Koloss were created by The Lord Ruler to fight for him and belong to his army. They are creatures that range from 5ft tall with loose, drooping skin to 10ft tall with large, well defined muscles. My imagined scenario for the koloss was centred on the idea that The Lord Ruler could give them a uniform when first created, to identify they belong to him, and as they grow they can use the adjustment mechanisms to make areas bigger or smaller to fit their body. This means they only need one uniform size throughout their life. During the design development process, I had to think about how a design detail or mechanism would work for the extremely different size variations between the smallest and largest koloss, and all other sizes in between.

The schema presents a suggested workflow and uses the above case study of personal work to show how I have used the workflow, weaving between physical and digital workspaces. The methods used within this project explore digital patternmaking, digital 3D simulation and physical making and draping. The case study for this project includes a shirt and trousers that can fit two extremely different bodies and have adjustment mechanisms to fit the bodies that are between these two extremes. Having one pattern that fits both reduces the need to spend a lot of time creating many different sized patterns for an army of background characters. Once the garment has been digitally sewn together on the larger koloss, the whole garment can be copied to the smaller koloss and then adjusted to fit. I explored the practicalities of using digital technologies to aid in the development of a more complex garment. My grounded knowledge in manual patternmaking and garment construction allows me to understand when it is best to explore in the physical workspace before translating it to the digital workspace. Having this previous practical knowledge helps with the efficiency and accuracy within a digital workspace.

Literature review

How technology has changed costume making for film

As computer-generated characters wearing digital costumes in film become more advanced, it is important for costume designers who are making physical costumes to be exploring digital technologies. Having an understanding of digital technologies and processes allows the communication between physical manufacturing and DCCA teams to happen more fluidly. If a physical costume designer can engage with 2D and 3D digital technologies, they can share digital resources with DCCA teams. This helps create an outcome that is more accurate, authentic and believable on screen rather than DCCA, that have not had training in garment making, creating costumes by relying solely on reference material to know where details (such as seams) may need to go.

CGI and motion-capture animation (MoCap) allows for ‘synthetic’ characters to do things that humans cannot do (Scott Ross as quoted in Nadoolman Landis, 2007). Examples include the actual character pushing the boundaries in the way they look and/or act, or physical costuming limitations. For example, digital fabric budgets are not an issue, as you can get any fabric in any colour (Ruth Myers as quoted in Nadoolman Landis, 2007). Digital costumes can also allow flexibility in design changes. A movie can be filmed with actors wearing MoCap suits while the costume design is simultaneously being developed. Shooting with MoCap also gives the DCCA a clean slate to work with, instead of working around or fixing a physical costume in post production.

PROCESS	CONCEPT DESIGN	COSTUME DESIGN	PRODUCTION (PHYSICAL)	CGI (DIGITAL)
	→	→	→	
AREA	ILLUSTRATION	FASHION TEXTILES	INDUSTRIAL FASHION TEXTILES	FILM ANIMATION

Figure 1: Processes and roles within the film industry (2018).

“The utilisable aspect of virtualisation suggests boundless potentialities for digital costumes.”

-(Kang, Cassidy, Cassidy & Li, 2015, p. 3)

Traditionally, in relation to digital costumes, the role of a costume designer was to create reference costumes that may be more for inspiration to the DCCA rather than a final design (Johnston, 2012). Costume designers may receive drawings of designs from concept designers, that require further design development to build a realistic perspective of how fabric drapes or where seams need to be placed so that it works on a body (Interviewee C, 2019). There can be a disconnect between a physical costume

and a digital costume being made even though both departments are working on the same costume (Interviewee A, 2018). A physical costume can be sent to a digital department and someone from the costume department might be on set when videos and photographs are taken to see how the garment moves. However, the digital department would not traditionally ask for input from the costume department even though the results would be better (Interviewee A, 2018). Once the costumes are handed over to the digital team, the costume designer no longer has control over how those garments look for the final outcome. Digital costumes would be made as 3D shapes, either as a 3D scan from a physical costume or as a 3D model which would be a DCCA’s interpretation of the physical costume (Interviewee C, 2019). It is becoming more common for concept designers to have a costumer give input into the concept design. This expands on the role of the costume designer and allows for a better workflow for the workrooms (Interviewee C, 2019). Choices that seem obvious to a costume designer can be communicated to the DCCA to produce something believable (Isis Mussenden as quoted in Nadoolman Landis, 2007).

There will always be a place for costume designers even with the rise of digital costumes (Johnston, 2012; Interviewee C, 2019). Digital techniques build upon the analogue, and without this knowledge the maker will eventually hit a wall where they cannot take the digital any further (Prince, 2012). The understanding a costume designer has about garment construction and how the fabric behaves is now even more integral to guarantee a garment is grounded in reality. With further demand for more realistic CGI experiences from audiences, DCCAs are once again going back to costume designers to have their expertise as part of the process when creating a digital costume (Castonguay, 2016). Traditional costuming skills such as character analysis, research and costume making will always be the foundation that costume designers need, even with the use of digital technologies. These technologies may give designers new, interesting opportunities within the film industry but the foundational skills can not be automated or digitized (Nadoolman Landis, 2007).

Accuracy between physical and digital garments for authentic outcomes

Research papers that discuss the replication of garments predominantly look at the use of 2D patternmaking and 3D simulation technologies to create authentic digital copies of historical garments. These studies use a mix of reference photos, illustrations, historical published patternmaking and construction documentation, and garments to check the accuracy of the digital reconstruction. The physical garments are analysed by looking at pattern shapes and measurements, garment fit, details such as pleats, gathers and boning, fabric composition, and construction techniques. From this analysis, a digital replica can be made onto an avatar using digital 2D patterns, and comparisons can be made to the original images or garment to check the accuracy (Kuzmichev, Moskvina, Surzhenko, & Moskvina, 2017; Kuzmichev, Moskvina, Moskvina, 2018; Kang, Cassidy, Cassidy, & Li, 2015)

When using 3D garment simulation systems, you can replicate a garment without using all of the same techniques that may be used if creating it physically, whether it is a historical or contemporary garment. An example is adding steaming allowances that would have appeared in historically created tailored garments, which were used to stretch and shrink the fabric to fit the body (Kuzmichev et al, 2017; Kuzmichev et al, 2018), or adding fusing in areas that need extra strengthening to hold design details without ripping or to avoid stretching the area. When creating a digital garment, it is important to have an understanding of these considerations that would be used when creating a physical garment or else it can affect the accuracy of the reconstruction (Kuzmichev et al, 2017). An alternative method is 3D scanning the garments to create digital garments that are more realistic in appearance. However, the digital outcomes do not have the capability of fabric drape being applied due to the surface of the garment being converted to a single object, rather than its individual structural factors (Kang et al, 2015). This creates a superficially realistic garment with components that cannot be separated.

These methods and ways of thinking can also be applied when creating digital costumes, whether it is a historical replica/period piece or a new costume design. Kang et al (2015) suggests authentic reproduction of the original garment as one of three desirable attributes for digital costume effectiveness. Digital costumes can be created by replicating a physical costume that is made by a costume designer and passed on to the DCCA, or it could be created by looking at reference materials that are relevant to the costume being created. If reference material is used instead of using a costume, complete with samples and patterns, a person that specialises in garment making needs to be brought in to help break down the reference material. Engaging many specialists can be costly and cost-time efficiency would need to be a priority (Kang et al, 2015). However, by engaging an expert early, money and time can be saved in the long term.

“However, the simulated garments must be accurate representations of real garments for consumers to accept this technology”

(Kim & LaBat, 2013, p. 171)

Film industry roles and processes with technology: Interviews

Initial research included interviews with experts from costume departments in the New Zealand film industry and an online survey open to worldwide participants. They came from a range of training backgrounds and levels of industry experience. Many trained in fashion design but also industrial design, as well as textile design. There was a mix of self-taught and formal training. All worked in production and fabrication with two participants considering their current position to sit within concept design as well. Participants were found through mutual contacts and personal communication. The questions focused on their experiences where they have collaborated with other practitioners, both physical and digital designers and makers, to achieve the desired costume outcome. This included discussing the processes, systems and digital technologies that made the collaboration easier and the relevance they saw in digital technologies for the costume industry. Talking with these experts validated where my project sits within the current film industry and confirmed that digital departments are

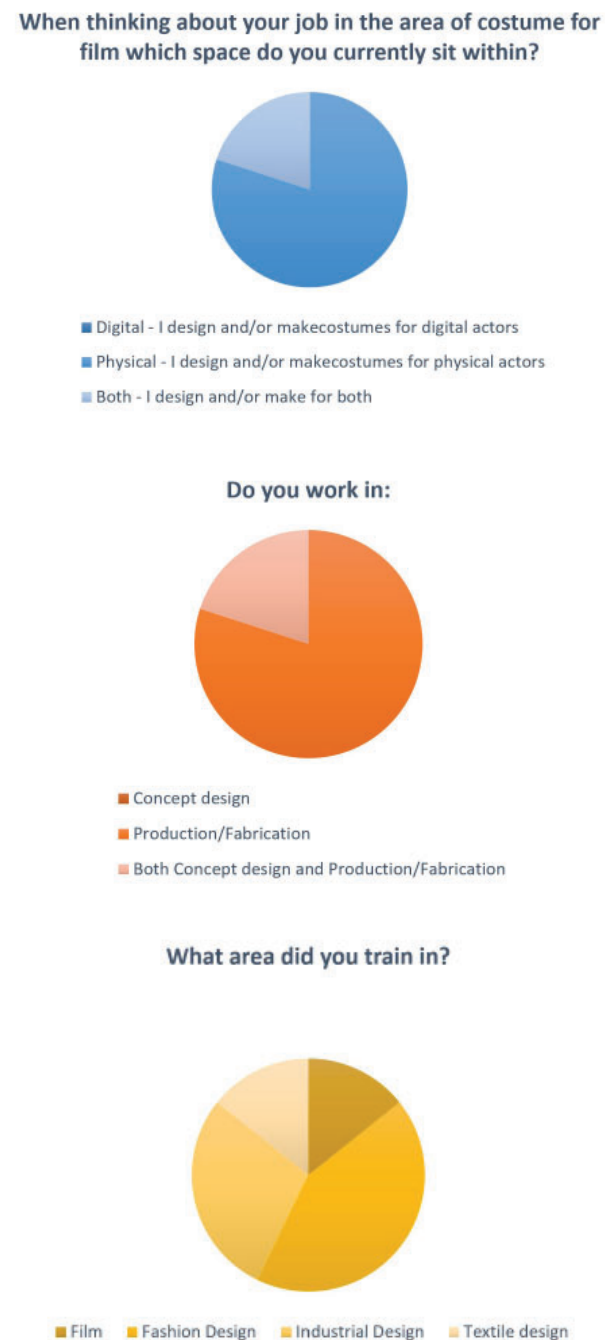

Figure 2: Results of data gathered from interviews and surveys. (2019)

engaging with costume departments more frequently to achieve realistic results in computer-generated costumes.

Some of the participants have the opportunity to regularly work in collaboration with a range of people outside of their own departments. The participants that experienced collaboration also sat between concept design and manufacturing/fabrication. Collaboration can be an integral part of the daily job as different costume components are passed through various physical and digital departments. Currently, the cross-over between physical and digital makers is limited, this is probably due to different companies working on each of the outcomes. It is common for the physical costume department to supply the DCCA department with final samples and garments. Someone from the costume department may be on set when the actor is scanned wearing the costume to see how it moves but otherwise the work is passed over and left in the hands of the DCCAs.

Concept designers and DCCAs are more frequently using Marvelous Designer which shows a big shift in thinking from costumes seen as 3D objects to costumes seen as 2D shapes creating a 3D form. It is becoming more common for traditional costume designers to be brought in to help with the creation of digital costumes. This allows the costume designer to teach them about traditional patternmaking and let them know why something might not be working. When the digital and physical processes are integrated it creates a better product because you are combining the expertise and knowledge of both departments instead of relying on guesswork. Many of the participants want to expand their knowledge within digital technologies, even if it is only obtaining a basic understanding in order to communicate with digital departments. However, there is an issue within the industry of being unable to provide enough time to develop and research new methods of making and processes. This is a common issue within any professional design industry.

Although only one participant worked in both physical and digital costume making, all participants believed it was important to be looking at digital technologies for costume design and making but also agreed that upcoming generations should not solely focus on digital making. The participants felt it is key that they continue to understand traditional, fundamental techniques in real spaces and have the ability to see the relationship between 2D and 3D shapes. They felt that if they do not have this understanding, the final outcome is not going to look the way that it is intended.

Patternmaking methods and systems

Patternmaking from blocks or the adaption of existing patterns is widely used by the fashion industry to ensure accuracy in sizing and speed in the development of new ranges. Alternatively, common in couture design, patterns can be created by draping on a mannequin (Aldrich, 2015). A block is a foundation pattern, made to fit an average figure, it has a specific fit and includes ease for functionality. Even if the patternmaker adds in style lines, fullness or drape, the basic fit of the garment will be dictated by the block (Aldrich, 2015). In fashion, it is important to create balance in garments to fit the body. There are mathematical systems in pattern and garment cutting that have been developed over centuries so that ideal garments can be created for a perfectly proportional body. Using these foundational systems, patterns can be changed to fit a body with extreme variations of body shapes. It is possible to use direct measurements and trained judgement to work out proportions for the non-standard body that is being dressed, Croonborg (2005) describes working between these as “The Supreme System”. The need to go between the two is due to the inability to get exact measurements from a client every time. A measurement can be variable due to the measurer’s judgement, change of stance, different garments worn or even just by breathing. This can not only change circumference measurements but also measurements that relate to each other (Croonborg, 2005). Relying solely on measurements could result in a garment that is unbalanced.

This same issue, the need to work off measurements, can arise when working in a 2D digital space. Although direct measurements can be helpful for straightforward applications when combined with fundamental knowledge (Croonborg, 2005), the ability to see whether a line needs to change a small amount to create balance in the garment can sometimes be difficult due to the small scale of the pattern pieces on the screen. This may mean a physical sample needs to be made to check the balance, with lines drawn directly onto it and then measurements taken off of these samples to input back into the pattern design system (PDS). With the introduction of 3D software such as CLO, this issue can be often avoided due to the ability to see the garment on a 3D body and either draw directly onto the 3D garment or adjust the 2D pattern while the 3D garment automatically updates.

CAD (Computer Aided Design) systems are used to improve material utilisation, create accurate patterns, and lower production times (Aldrich, 2008). In the fashion industry, this allows for a quick response between customer and supplier (Gray, 1998), and supplier and manufacturer. Generally, CAD allows most changes to happen quicker than manual methods, whether they are minor or complex.

Fashion businesses that use CAD are able to send their digital patterns all over the world and this flexibility allows changes to be sent to manufacturers at short notice (Aldrich, 2011).

PDS can be used to directly draft blocks and patterns from a drawn design or take previously created blocks and patterns and modify them to create a new style. The software is able to perform standard pattern adaptations such as editing darts, changing the length, creating design lines, and adding fullness. It can also quickly perform tasks that can be time consuming to do manually, such as tracing pieces from a master, checking seam lengths and seam runs, adding seam allowances, labelling, and accurately grading many sizes and pieces at once (Aldrich, 2008).

Some pattern designers may choose to start with creating a pattern manually, either because of the complexity of the pattern or not having enough experience to create a pattern using PDS software. They would then use CAD software to tidy up the pattern perimeter, add seam allowances and labelling, grading, and create production documents such as markers. If this is the case, patterns can be digitized into the system using a digitizer. An electronic cursor that has a specific sequence of functions is used to input the pattern that is placed on the digitizer board. All details of the pattern can be entered while digitizing. These details include identifying corners and smooth curves, grainlines, notches, internal lines and buttonhole placement. Graded points can also be entered during digitizing or can be specified later in PDS (Aldrich, 2008).

Once the pattern pieces have been checked and are ready for prototyping, individual pieces can be plotted out on a large plotter. If the design is complicated or uses a large amount of fabric, the pattern pieces can be plotted at scale and then fitted on a scale mannequin. When the pattern is ready for production, a marker can be made. The marker can be plotted for manual cutting or sent directly to a cutter, either deep-ply for many layer, or single-ply for customised garments.

Physical and digital methods of making

Mannequins, live fit models and avatars

Mannequins and live fit models enable the designer to check proportions, design lines, movement ease and the fit of a physical sample. This is especially important when a design has been made from a block, as opposed to adjusting a previous design, or is in a more complicated style. Working on a 3D body also helps a designer to understand the relationship between 2D flat pattern pieces and the 3D body (Aldrich, 2015). Designers can also drape fabric directly onto the mannequin, checking and changing the design and fit along the way. Avatars allow the designer to do this work in a digital workspace by having a digital replica of the body they are dressing. 3D scanning can be used to convert physical bodies into 3D digital forms so that the user can drape and fit on the same shape in both physical and digital spaces (Kang et al, 2015). The opposite method can also happen where a maquette or a milled polystyrene body is created from a 3D body scan. This is common for costume designers who are working with actors around the world.

A disadvantage of using avatars is the lack of give in the body. Due to being made as a solid shape, the garment will sometimes stretch and mould to the shape of the avatar, while a real body will compress if part of the garment is tighter (Kim & LaBat, 2013). Interviewee A (2018) made a similar observation in relation to milled body scans being used instead of using the real life actor/actress. In that case, instead of conforming to the mannequin, the garment may be difficult to put on because of the lack of malleability in the polystyrene.

3D simulation for design and fit of garments.

3D modelling software has become standard use for design and prototyping in a variety of creative industries such as architecture, automotive, and industrial design (Seo, 2018). Although virtual clothing technology has been available since the 1980s (Magenat-Thalmann, 2005), the fashion industry has been slow to take up this technology. This is due to the need for upskilling in this area, computer hardware upgrades and the limitations of fabric simulation within the software. Computer graphics, outside of fashion and textiles, have previously given more importance to how accurate the cloth looks visually rather than the accuracy of how the cloth moves and drapes in comparison to real life. (Magenat-Thalmann, 2005)

3D software helps the user create a simulated garment in a virtual space and allows them to receive

visual feedback instantaneously. Garment simulation is performed by defining which points and lines on a garment pattern are sewn together, just as you would when creating a physical garment. Knowledge regarding how a physical garment goes together helps with the efficiency and accuracy in this process. A tension map can show how the garment fits when moving the body and X-ray mode allows the patternmaker to see where exactly the adjustments need to be made on the 2D pattern (Joseph-Armstrong, 2010). The user needs to have an understanding of how to assess and evaluate the 3D simulation to create accurate samples virtually on an avatar as an alternative to in a workroom on a mannequin or live model (Siersema, 2015). If the user can achieve this, the benefits of being able to work in a digital space are numerous. The maker can produce samples quickly and efficiently, permitting for multiple iterations of an idea in a reduced amount of time. There is a reduction of material used, and the maker can experiment with fabric patterns, types and colours, logos and other details, (Siersema, 2015). Working in a digital space also allows files and assets to be easily exchanged around the world between users allowing for the production of the same garment to happen in different locations and for different mediums (physical and digital).

It is claimed by Magenat-Thalmann and Volino (2005) that the best way to achieve an accurate 2D surface, which creates the 3D model, is to use a traditionally created 2D pattern. This can either be created in a CAD patternmaking software or drafted manually and digitized on a digitizing board. The user also needs an understanding of garment construction to take full advantage of creating garments in a virtual space. Without this experience, garment patterns can be completely incorrect and although visually recognisable, do not take into account the body shape, body measurements and ease that the garment needs for the body to move (Volino & Magenat-Thalmann, 2000).

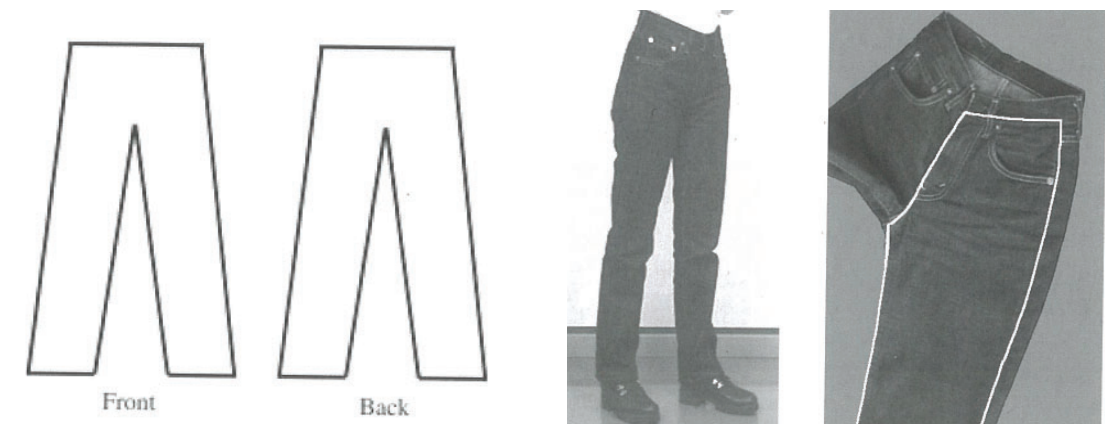

Figure 3: “Naive and incorrect” patternmaking example. (Volino & Magenat-Thalmann, 2000)

Figure 4: Correct trouser shape example. (Volino & Magenat-Thalmann, 2000)

Choi and Ko (2005) have discussed the need for an animator to engage a trained patternmaker to create accurate 2D patterns for digital characters alongside needing their expertise to create graded patterns for different sized characters. They have approached this from an animator's perspective, proposing it as a restriction that hinders good clothing animation and suggesting that more intuitive and automatic software is needed for those who do not have an understanding of patternmaking and grading. In reality, it takes years for a person to become an expert in patternmaking and relies on the experience of the patternmaker to make the correct adjustments. As the name suggests, CAD is used to assist in the process, it does not replace the expertise of a person nor does it perform work and problem solve automatically (Gray, 1998). This means that there is no way of having an automatic system, without a user's interaction, to create accurate patterns and grading, especially as the design becomes more complex (Choi & Ko, 2005).

A significant difference between fashion and animation is in the way the digital garment needs to be accurate. Within fashion, if the garment were to be used for prototyping and product development, there needs to be an accuracy in the 2D patterns to be passed on to a manufacturing team for real-life retail. To ensure this accuracy and the correct fit, an avatar or avatars that represent the designer's market will need to be created. This is especially important if the market does not fit into the standard athletic adult male/female range, (for example children, plus-size men and women, and pregnant women). Virtual avatars allow designers to prototype garments before production without the time consuming and costly process of using a fit model in a studio. The three main ways of achieving this is through altering the default avatars in a 3D simulation programme, having a customised avatar created, or using a body scanner to scan a mannequin or fit model (Kim & Ko, 2015).

By contrast, in animation it is important for the 3D model to look accurate to the eye when it is presented in a virtual world even if the garment may not work in the real world (Volino & Magnenat-Thalmann, 2000). As seen in case study 1 (Pogo, *The Umbrella Academy*), recently there have been important advances within the film industry to create a more realistic digital costume. In the past, fabric appearance would be modelled by hand with applied texture mapping. This process has drawbacks due to the finite details the fabric could have with the limited texture resolution. Weta Digital, in Wellington, New Zealand, has developed a new system that allows the costumes to be built from the ground up. It relies on the input of fibre and weave properties to create a digital fabric that has digitally spun and woven fibres which react to different lighting in the same way real fabric does (Robertson, 2019). This creates another area which the costume department can help the digital department. Through the costume department's knowledge of fabric structures, it can send fabric property information to the digital department along with real fabric samples.

Case study 1: Pogo, *The Umbrella Academy* (TV Show, 2019)

Pogo is a life-like, computer generated advanced humanoid chimpanzee that interacts with real-life actors in the TV show *The Umbrella Academy* (2019). Weta Digital was approached to create him due to their groundbreaking animation work in the *Planet of the Apes* franchise. (Zakarin, 2019). Pogo needed to be realistic, in order to blend in with the cast (Robertson, 2019). This meant the animation of the garments he was wearing also needed to be realistic. Weta Digital has developed a new system in cloth modelling that replicates the spinning and weaving that is seen in real world cloth without the need to hand model it and use texture mapping (Failes, 2019). A piece of fabric is no longer limited by the texture resolution but could have unlimited amounts of details for close up shots (Robertson, 2019). To create garments from the digital fabric, digital flat patterns were used to 'cut and sew' in to costumes that could then be rendered with wear and tear and peach fuzz pilling. The fabric could be rendered correctly by setting the properties of the digital fabric and comparing them to physical fabric samples from the costume department (Robertson, 2019). The costume department created a physical three piece suit that could have been worn if Pogo was a real character. The garment fabric was then examined under a microscope so that the details, including seams and other irregularities, could be inputted into the new system (Zakarin, 2019).

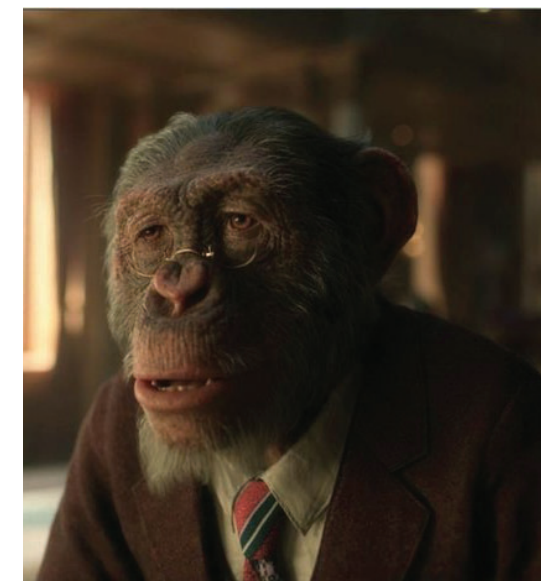
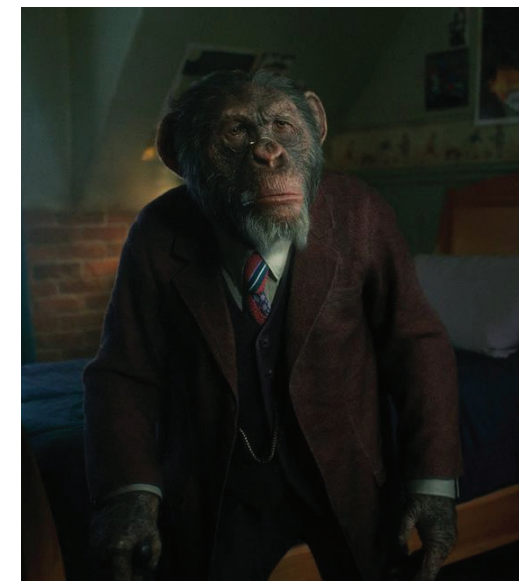

Figure 5: CGI Pogo in digital costume
Credit: Netflix (2019)

3D modelling software allows processes to be streamlined between design, development and making by using digital assets that can be shared by all departments (Seo, 2018). This also allows departments to focus on what they specialise in and for the development of ideas to flow back and forward more easily. The development of cloth simulation technologies allows creation of costumes that can dress imaginary and realistic characters. With the increase of motion capture within real sets, versus computer generated sets, the need for highly realistic characters has become more common and with this comes the need for realistic costumes (Volino and Magnenat-Thalmann, 2000). Director Robert Zemeckis believes that CGI fills a gap where characters can be brought to life that cannot be created with live action (Nadoolman Landis, 2007). Costume designer Joanna Johnston, who worked with Zemeckis on *The Polar Express* (2004), has said the technology allowed for a better collaboration between costume designers and digital designers. Costume designers can give their traditional expertise in the technical construction of costumes, fabrics and textures which can then be applied digitally (Nadoolman Landis, 2007). Digital costumes also expand the possibilities for fabrics as there is no fabric budget limitation (Nadoolman Landis, 2007) and also allows for costume textures that may be difficult or time consuming to create.

Case study 2: Alita, Alita Battle Angel (Film, 2019)

Rosa Salazar, who played the central character Alita, was filmed in a performance capture suit that was created by a costume designer specifically for *Alita Battle Angel* (2019). The custom designed suit allowed flexibility for movement and also enabled accurate placement of body markers for animation (Fordham, 2019). A costumier was brought in to dress Alita after the digital team had attempted to create digital costumes, but were having issues with fit due to a limited specialty in patternmaking. An extra challenge was presented in getting the fit correct due to the character Alita having a slender, manga-proportioned body. Physical garments of all 18 designs were created, either by sourcing and adapting standard patterns or draping on a polystyrene, milled mannequin. The garments were then filmed and photographed with the videos, photos, garments and patterns being distributed to the appropriate digital departments (Interviewee C, 2019). All of these become references which help the final digital costumes more accurate.

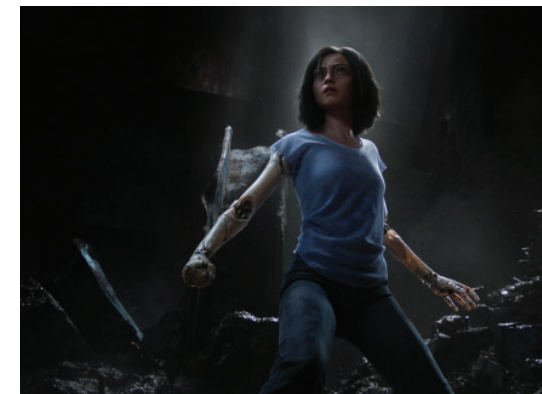

Figure 6: CGI Alita in digital costume
Credit: 20th Century Fox (2019)

Methods

The schema shows a suggested workflow for exploring digital technologies to create physical costume concepts. It uses an iterative design process that weaves between physical methods of design development and making and digital methods of design development and making. Cal Swann discusses in text *'Action Research and the Practice of Design'* (2002) that iterative design can only be effective if the problem is revisited, analysed and solutions are synthesised. The design process of 'planning, acting, observing, and reflecting in a systematic and documented study' is a research process. I have used this schema to show the cyclic workflow of my personal design project, creating a military uniform for the koloss character, as a case study.

STORYLINE AND CHARACTER DEVELOPMENT

Setting

- Ash fell from the sky
- In our way bright you stay whining a brilliant
- Most of the buildings had been built from stone blocks with the roofs for the wealthy and simple wooden shacks for the rest. The structures were packed closely together. Some stood high. The tenements and shacks were uniform in appearance. Investment through their city was a disaster or an economic? Again, I noticed with more of anger the picture or map and some... However, the spacing of the rows provided excellent locations for walls, built to give games their own through the room. Guards would all of them in through the room. Guards would all of them that were known were a really cultivated and kept by the mob.



Keywords:
Ash, smoky, stone, wood, brown, grey

Clothing

- Hundreds of people in brown smocks.
- The workers below wore simple coats and trousers, ash stained and worn.
- ...and the rest of a soldier. He wore a brown, seamless shirt.
- He wore modest clothing—a simple shirt and trousers with a loose knee jacket.
- I looked up, surprised in the soldier's suit. A white shirt covered by a deep green vest with a long, thin, curved blade. The black shirt had a matching black hat. His fingers sparkled with rings in the sunlight.
- ...copying a pattern. ...Tracing had helped to avoid getting lost in the new and old and not lost.
- ...checking his pocket watch.
- ...took off his jacket and vest. ...contacted his shirt, being the long garment being loose. The fabric was dark enough that it wouldn't give him away in the night.
- ...was dressed in simple grey blue clothing and a jacket and a pair of trousers.
- ...dressed in grey clothes.
- ...A hundred of brown hooded robes. ...He, the soldier wore a soldier's suit, colored red, blue, and brown, and a thin cloak to keep off the ash. ...initiative of Luthien middle class.

Keywords:
Ash stained, simple, modest, workers

Koloss

- And those figures were of deep blue. They varied greatly in size, some were tall and thin, others were lumbering bulk of fat feet or more. They were both the same species.
- ...a creature of smaller size—perhaps an elf, but it was not related with the arms and legs that it had. ...It was long and thin and thin.
- The creature looked like a fat man right, but all the fat had been removed leaving the structure of the body. ...And, the skin didn't seem to be completely smooth. ...Around the creature's neck, blood drip veins, the skin sagged, revealing the facial muscles. ...The same was true around the mouth. ...the lower teeth and jaw completely exposed.
- ...The body continues to grow, but their skin doesn't.
- ...The skin of the creature. ...The largest creature's skin was pulled as tight as if it was hanging by hair. ...The texture of the skin was dark enough that it wouldn't give him away in the night. ...Even where the skin wasn't torn. ...The pulled back the skin tight about it being an enemy. ...He was wearing about it being made up of men. ...The army was designed to only the most practical and possible. ...If there were no needs, no demands, no forces. ...And hundreds of large cooking fires, each unique with figures.

Keywords:
Blue, variable sizes, hairless, simplistic

UNIFORM REFERENCES

Keywords:
Functional, utilitarian, soft tailoring, structured, adjustable.



AVATAR AND MANNEQUIN DEVELOPMENT

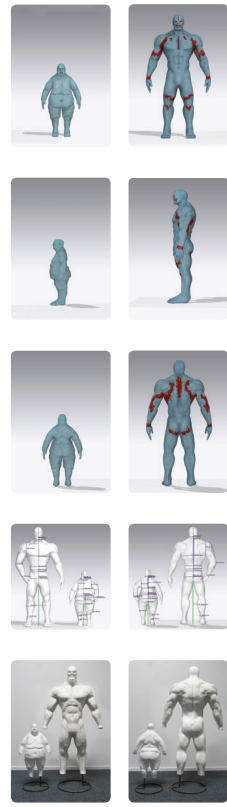

COSTUME DEVELOPMENT

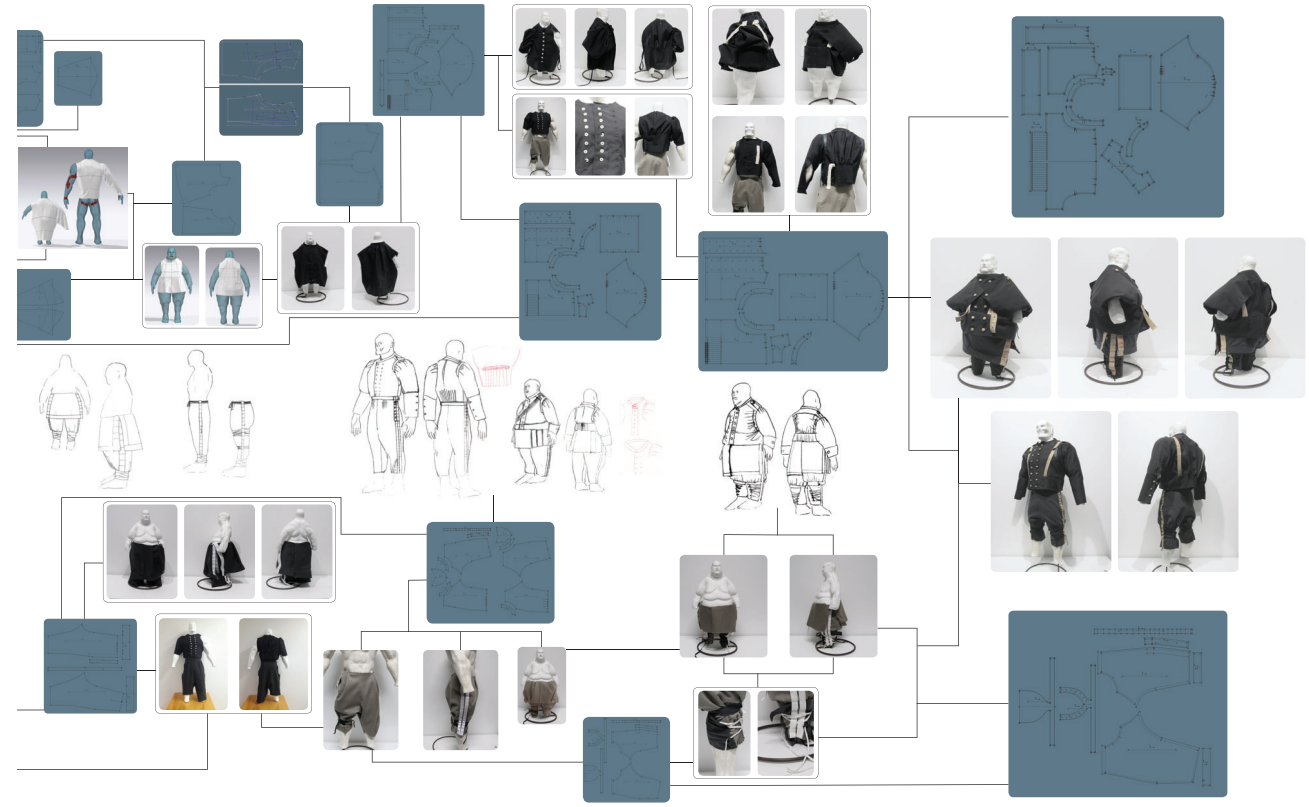
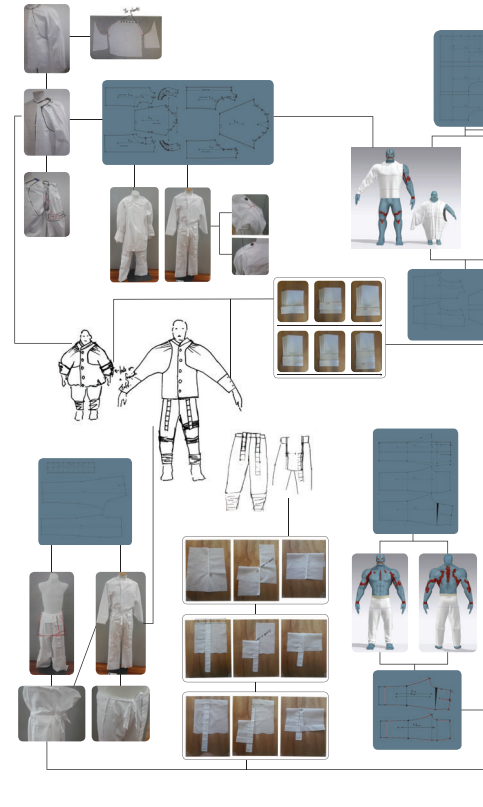

Storyline and character development: koloss

For this project I chose to use a pre-existing fictional character and environment to ensure they were grounded and well established. The character portrayed in this project is my interpretation of the koloss creature from Brandon Sanderson's *Mistborn: Era 1*, a series of fantasy novels. The series is based in The Final Empire, a state in the Northern hemisphere of Scadrial. Before the ascension of the Lord Ruler, known as Rashek when he did not have godly powers, Scadrial was earth-like with blue skies, green plants, and animals. After taking the power from the Well of Ascension, Rashek alters the location of Scadrial and it becomes characterised by ash falls, red skies, brown plants and nightly mists. The Lord ruler created new creatures, one of these, created through Hemalurgy¹, was the koloss.

“...he made soldiers, which we call koloss.”

- (Sanderson, 2008, p. 352)

Koloss were created to be soldiers in the Lord Ruler's army. They are seen as barbaric and of diminished intelligence. Koloss are similar in build to men with two arms and legs. However, they have deep blue skin, red eyes, are completely bald and vary greatly in size. A young koloss can start at five feet tall and is created with all of the skin that it will ever have. This means the skin hangs loose on the body, creating folds, and sagging skin around the face. As a koloss ages and grows larger, anywhere up to twelve feet, it becomes stockier and more powerful. As this happens the skin is stretched taut and eventually begins to tear. “Human” is a koloss that is introduced later in the series that shows readers that koloss have a basic understanding of some basic human ideas. Readers learn, from Human, how koloss are created and why some koloss have a higher level of human traits.

¹ Hemalurgy is one of the three metal powers within Scadrial, using metal spikes through the body to transfer powers between humans to create new beings.



Figure 7: Lewis, Jess. The new costume designer. Work book page.
Collage/mood board of found imagery. (2017)
Illustrations: Ben McSweeney

- What is the environment of the character?
- Where does it live now?
- Does it have a name, family, clan, tribe or other affiliation?
- Is it based on myth, legend, someone's writing, or other sources?

Other questions ensue:

- How was it born (hatched, created etc.)?
- What are its physical characteristics?
- Does it have strengths or flaws in its personality?
- Is it educated, literate, illiterate, intelligent, crafty, stupid, dull, or some other related trait?
- Does it have a job? Skills?
- What is its financial status (if there is such a thing in the story)?
- Does it have tool savvy?
- How about favorite foods, hobbies, or other tastes?
- What sort of body language does it use?
- Does it have a costume or other coverings or accessories (including props or mechanical contrivances small enough to fit an individual being)?
- Is it "cartoony," realistic, or fitted into some other stylistic genre? (This latter question is addressed more fully in Chapter Six).
- Is the character disguised?
- Does it have a certain range of emotional states?
- Do servants, harems, business associates, or other characters flesh out its feel or characteristics?
- In its history, are there triumphs, failures, traumas, or other significant events?
- Is it generous, selfish, superstitious, oafish, clumsy, petulant, or some other of a host of other possible personality qualities?
- If an action-type character, would it be characterized as more offensively or defensively oriented? What are its physical capabilities?

More questions may ensue related to a specific project:

- Will the character be animated? What is the size of the character in relation to its surroundings?
- Will the camera (if filmed or similar) be close or far?
- What is the size of the character in relation to the other characters?
- How many angles will it be viewed from?
- How much movement will it have?
- Will we see the face, with emotions, and will it speak or utter any kind of sound?

PHYSICAL TRAITS

Humanoid derived

- 2 arms
- 2 legs
- 1 head
- same skeletal and muscle structure as humans

Large size

- Range between 5ft to 12ft
- Grow as they age.
- Once they reach 12ft they will die due to heart failure

Blue skin

- Born with all the skin they will ever have so younger ones will have very baggy skin which stretches and tears as they grow older.
- Elders will have leather wraps due to having no skin.

Creation

- Created and controlled by the Lord Ruler to fight for him.
- Hemalurgy: four humans are stabbed with individual iron spikes which are strategically placed on a fifth.
- They are given superhuman strength ("Blessing of Potency") but diminished mental capability.
- The spikes can be re-used but the Koloss that is created will stay more human (less strength, more intelligence). The Lord Ruler did not want this but is worked out by Koloss for reproduction purposes.

KOLOSS

Creature from Brandon Sanderson's Mistborn series
definition: koloss
Origin: German
masculine noun
colossus, giant, hulk, jumbo, behemoth

Emotions:

- Bored or angry.

Barbaric

- Fight each other when bored.

Controlled by Allomancy

Diminished intelligence

Straightforward

- Controlled by humans with the power of soothing-creating a loyal army

Props- coin pouches, swords

- Carry pouches with coins in them, which they have been paid but the coins are useless to them.
- Fight each other for swords

OTHER

MENTAL TRAITS

Figure 8 (Left): "Character ingredients" questions. (Hedgpeth & Missal, 2006)

Figure 9: Lewis, Jess. The new costume designer. Workbook page: Breaking down the character "Koloss" (2017)

Avatar and mannequin development

3D modelling for garment design requires an avatar to drape and create the garments on. This project required a non-standard body to be dressed, meaning customised avatars needed to be created. The avatars were created at the smallest and the largest body size ranges of the koloss. This enabled me to design for these two extremes, while considering the multiple variables in between. After developing physical sampling on a standard male and child mannequin to explore design ideas, I realised I was also going to need to have a physical copy of my digital avatars. This helped me to check the design details that I was physically trialling in respect to scale and fit on the two bodies that I was designing for. Working in both digital and physical environments meant I could go between the two, keeping everything that I created visually and functionally in scale with each other. The avatars and mannequins were created in collaboration with other local makers that specialise in these areas so that I had a product that would not disadvantage my end project.

Avatars for digital work

To create the koloss bodies, I took quotes collected from the *Mistborn: Era 1* series Trilogy, and started to sketch what these bodies could look like. Initially, I explored the avatar editor function in CLO. Through this function users are able to change various areas of the default avatar which allows users to make adjustments so that the avatar more accurately represents the body users are dressing. During this exploration I experimented with how extremely different I could make the bodies. What I discovered is that I could create what would be a very large human but found that the extra bulk which was added was not so much muscular but more like fat being added to the body. After this discovery and deciding that I would not be able to create the two avatars that I needed through CLO I exported one of the default avatars from CLO and imported it into Pixologic ZBrush, which I had not had the opportunity to explore before. Here I was able to experiment with building bulk onto the body which finished in a base result that, with some additional work, I was happy with. When this avatar was imported back into CLO it no longer had a skeleton, which was key for checking the fit of the costumes.

Experimenting with these two programmes allowed me to more easily communicate and understand what I needed from a maker that specialised in this area.

I put together a proposal outlining the requirements needed for the avatars:

- Two avatars, one of each size, in scale to each other;
- The avatars include a basic skeletal structure to allow for testing of movement and fit;
- The large character needs to show areas of skin tearing;
- A file format that will work for CLO (.avt);

Two customized avatars with skeletal structures were created in collaboration with industrial designer Cameron Doidge, using Pixologic ZBrush to create the avatar shapes and Blender to rig the avatars with a skeleton. The final avatars were exported in a variety of formats so that I could use them in different ways.

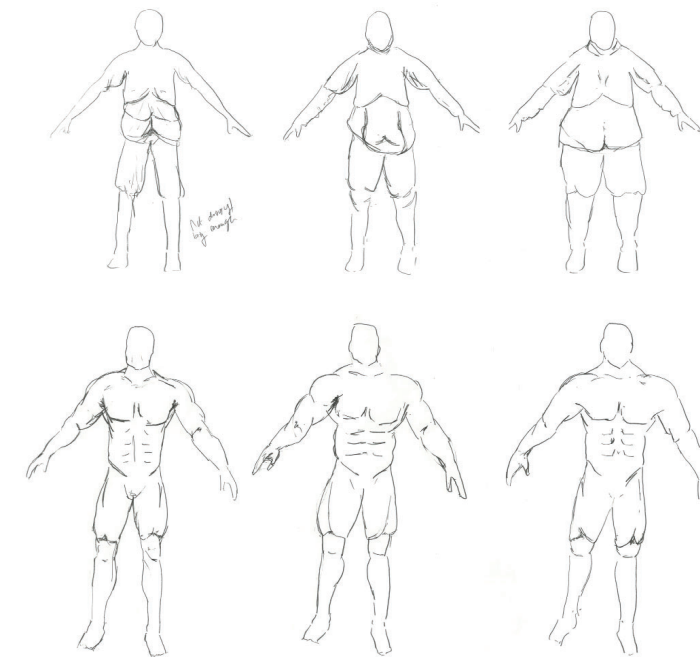
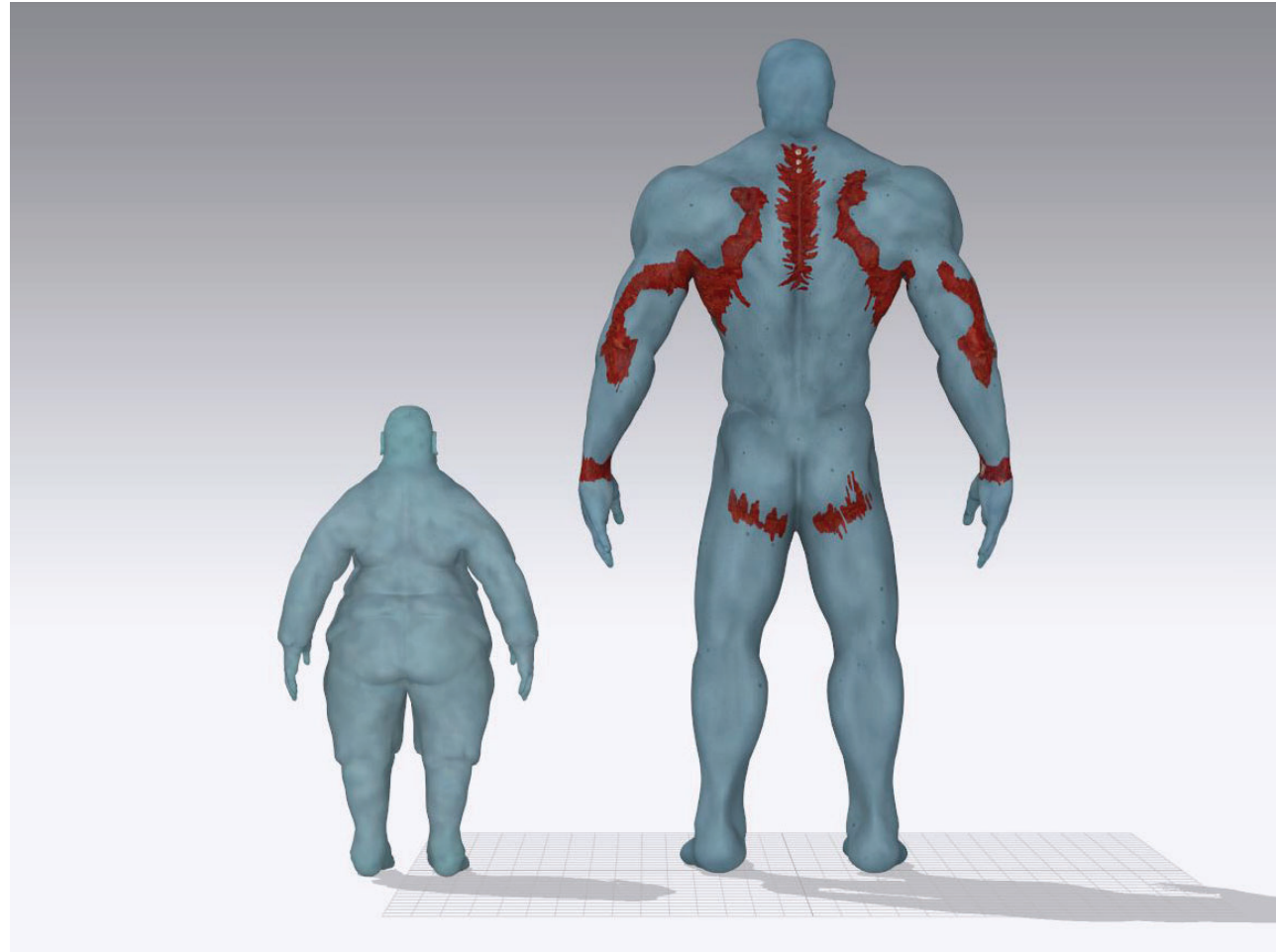
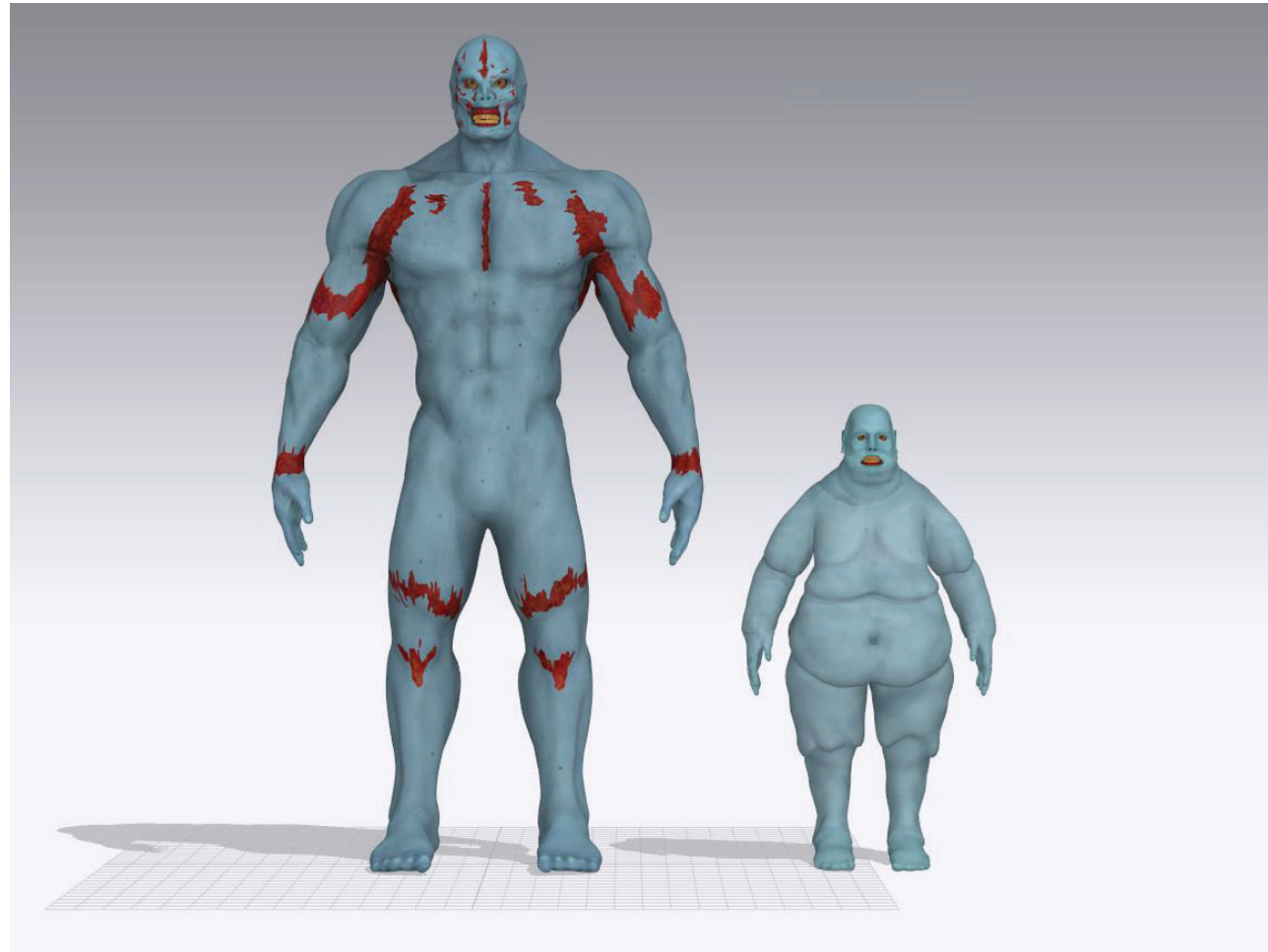

Figure 10: Lewis, Jess. The new costume designer. Workbook page: Sketching “Koloss” (2018)

Figure 11: Process images from Cameron Doidge, creating the avatars (2018)



Preparing the avatar

Bounding volumes and arrangement points can be used to make garment arrangement easier in 3D. These can be copied from other avatars or created independently. Due to my avatars being a non-standard size, I have created my own bounding volumes and arrangement points, alongside editing the defaults.



Using a measurement chart guide from *Metric Pattern Cutting for Menswear* (Aldrich, 2011), measurements were taken on both avatars in standard areas (Table 1, p. 39). These measurements helped work out the areas where there was extreme growth between the two bodies and were used to create pattern blocks. Additional measurements were added throughout the patternmaking process.

Figure 12 (Left): Lewis, Jess. The new costume designer. Final avatars in CLO (2018)

Figure 13: Lewis, Jess. The new costume designer. Final avatars with bounding volumes and arrangement points in CLO (2018)

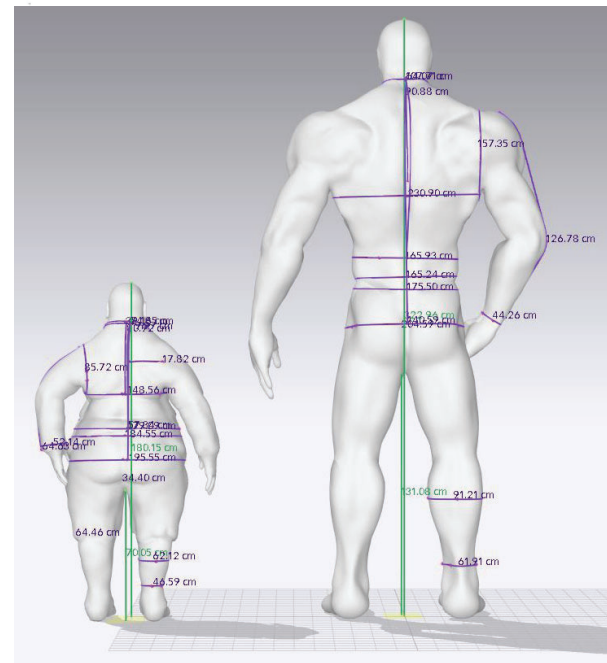
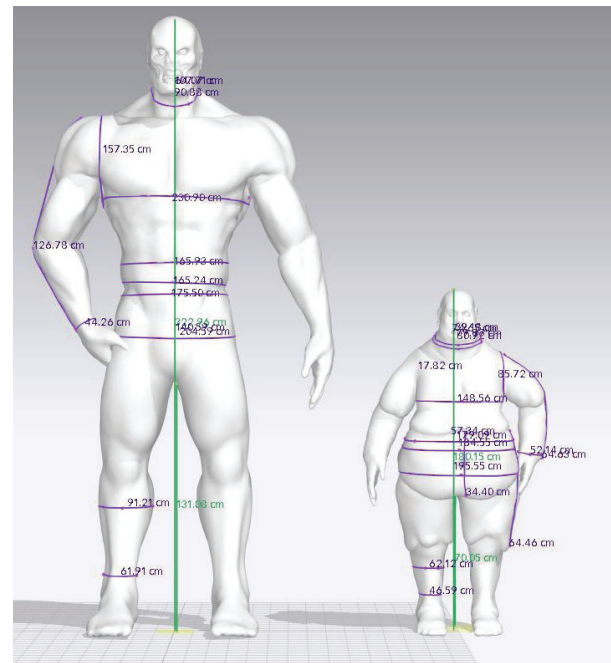
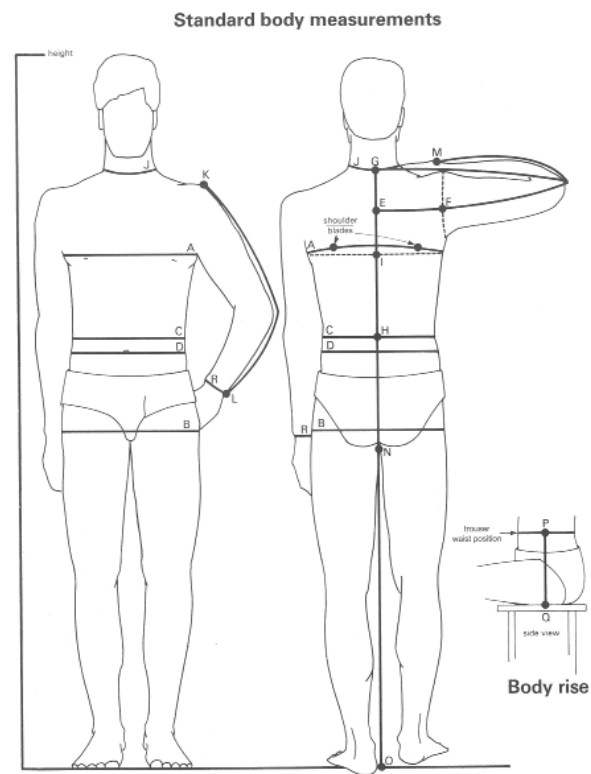

Figure 14: Standard points of measurement. Aldrich (2011)

Figure 15: Lewis, Jess. The new costume designer. Final avatars with points of measurement in CLO (2018)

		Standard	Small koloss	Large Koloss
A	CHEST	96	146.3	254.9
B	SEAT/HIP	98	195.6	204.6
C	WAIST	82	179.1	165.9
D	TROUSER WAIST POSITION (4-6cm below waist)	86	184.6	175.5
E-F	HALF BACK	19.5	20	40
G-H	BACK NECK TO WAIST	43.8	57.3	107.7
G-I	SCYE DEPTH	23.6	39.2	58.9
J	NECK SIZE	39	81.1	90.9
K-L	SLEEVE LENGTH one-piece sleeve	64.2	64.6	127.3
N-O	INSIDE LEG	79	70.0	131.1
P-Q	BODY RISE	27.8		52.1
R	CLOSE WRIST MEASUREMENT	17.4	52.1	44.3
	HEIGHT*	-	180.1	323.0
	SHOULDER CIRCUMFERENCE*	-	85.7	142.1
	CALF MEASUREMENT*	-	62.1	91.2
	ANKLE MEASUREMENT*	-	46.6	61.9

Measurements in cm

*Extra measurements needed for designs

Table 1: Lewis, Jess. The new costume designer. Chart of Standard points of measurements vs small koloss vs large koloss. Standard measurements: Aldrich (2011)

Mannequins for physical work

The files created for the avatars were exported as OBJ files, these were sent to Human Dynamo to be used on a CNC router. One third scale was chosen due to the size of the larger koloss, this size was small enough to fit on to the CNC bed but still allowed enough size on the smaller koloss to experiment with ideas. The files were edited so the hands and feet were removed due to fragility that would happen in those areas and the bodies were split down the middle to deal with the undercuts on the bodies. High density polystyrene was used with a 16mm ball nose cutter to cut down on machining time.

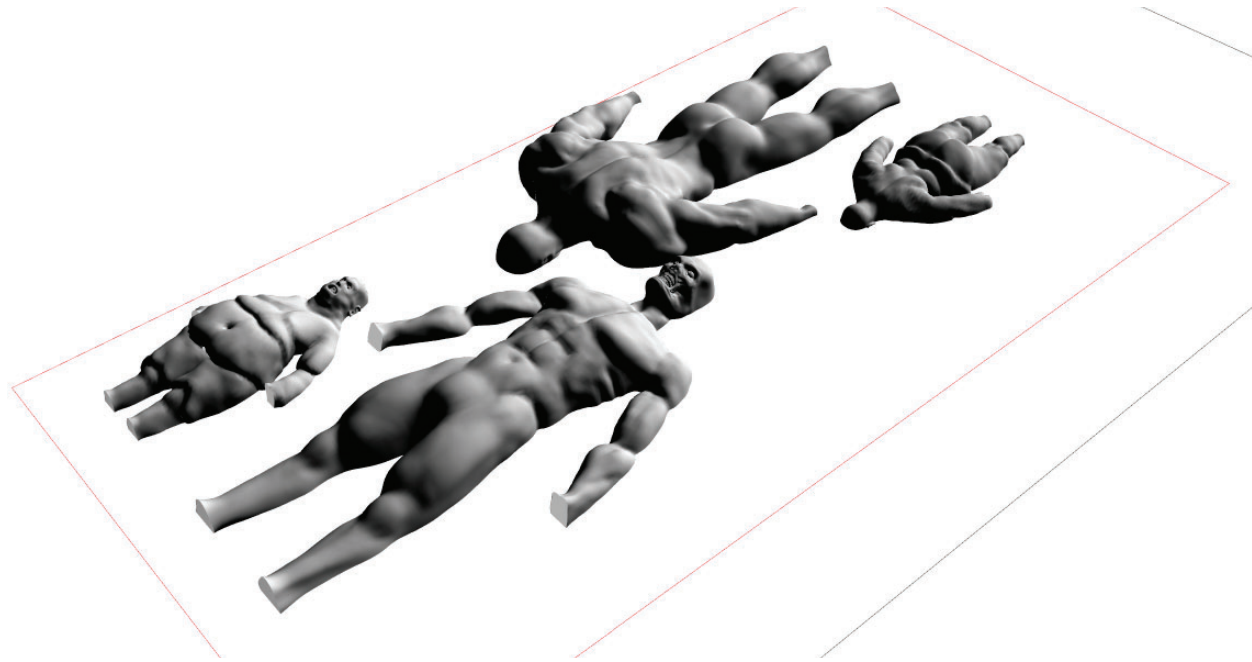

Figure 16: Process image from Cameron Holder, creating the mannequins (2019)

Preparing the mannequin

As the mannequins were created in two halves, I needed to join them together which I did with double sided tape. Due to the design of the avatars and all of the undercuts, there were a few areas which did not line up perfectly and areas which had webbing. For this project, because I was not creating skin tight garments, this generally was not a big issue. I did cut away some areas, like under the arm and between the legs, where it would affect how the garment sat on the body and the fit. Once the two halves were joined together, a hole was drilled through one of the legs so that it could be placed on a stand.

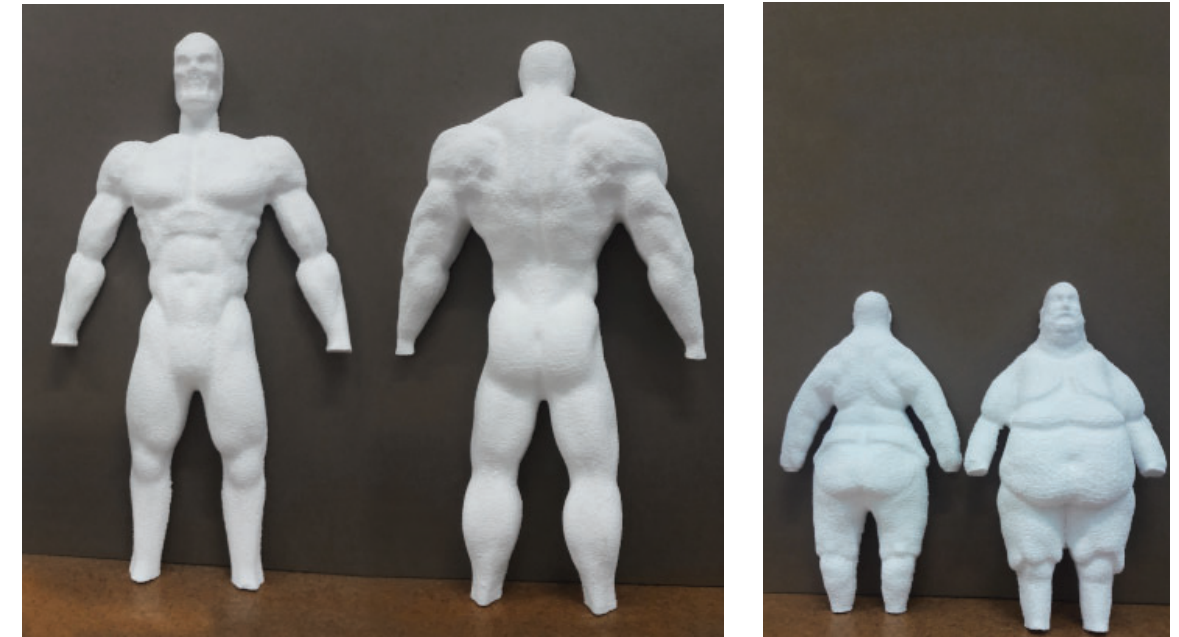

Figure 17: Lewis, Jess. The new costume designer. Process images of preparing the mannequin: sticking the two halves together and cutting away excess areas (2019).

Figure 18 (Bottom right) : Lewis, Jess. The new costume designer. Final mannequins on stands (2019).

Costume design development

Koloss belong to the army of the Lord Ruler. Although the koloss are not given clothing from the Lord Ruler in the books, I wanted to portray an interpretation of a human uniform that the Lord Ruler could give to the koloss which shows that they belong to him and his army. Uniforms are essential where identification between different groups is needed. They create a distinctive mark to show that the one who is wearing the uniform belongs within the group and may also show their status or rank within that group (Craik, 2005). By giving the koloss a costume that resembles a uniform a human may wear, this shows they belong with the humans. Therefore, an audience can connect with the koloss more easily. An audience may initially feel fear or repulsion towards these creatures because of the way they look but this connection is important for character development as we learn that they are created from, and have traces of humans. Due to the limited supplies in *The Final Empire*, I made the assumption that the Lord Ruler would not be wanting to spend money on the renewal of kits as they grew. My design problem is based around the idea that the Lord Ruler would give the koloss the uniform when first created and as the koloss grew, it could adjust the garments to fit their changing bodies. The aspect of multiple sizing gave me added challenges when looking at believable and authentic costume design.

Design keywords: adjustable, soft tailoring, uniform, utilitarian, camouflage, practical, functional, understated, familiarity, structured

Creating a one size fits all uniform

Coming from a background in fashion design and making, where garments have to work for real people, I wanted to challenge myself to create costumes that did not need to rely on ‘movie magic.’ This refers to when something within the movie works when it would not work in our real world and sometimes makes the character less grounded in reality. A good example of this is the film variations of the Marvel Comics “The Hulk”, when his body changes he is always depicted wearing trousers with small amounts of tearing in the fabric, even though he doubles in size from an average sized man to a large, muscular superhero. In reality a tailored trouser would tear apart completely, just as they have depicted for his shirt and shoes.

I had to create a seemingly simple costume due to the enormity of size difference between the two stages of the koloss character. At the beginning of the design process, I took the measurements from both avatars and started to look at where the size differences were happening between the two bodies. It was important to see the minimal dimensions and amount of cloth needed for the large koloss to have a functional garment that allowed for ease of movement yet could be manipulated through folds so the small koloss could carry it easily and be practical. Functionality was an important aspect of my design and I wanted to use mechanisms that were easy to use and adjust. This decision was made not only to fit with the intelligence level of the koloss character but also because of the practicalities of dressing actors, whether real or digital, as the koloss could be seen as background characters most of the time, with the exclusion of the koloss Human.

In areas of the body that have a lot of growth, for example the chest, shoulder and bicep area, I explored ways in which I could use gathers and pleats to add fullness but that it would still allow the garment to sit in a structured way. There were options of draped and fluid shapes in areas but to maintain a uniform appearance, I considered it important to keep it as structured as possible and have the size adjustments happening in a very controlled way through tabs, channels with drawstrings, lacings and buttons.

Throughout this process I have referred back to design details from historical, Euro-centric military uniforms, focusing primarily on field uniforms worn by infantry, to allow the viewer to make connections between the costume and functional military uniform. However it was important to keep the historical time frame undefined so that other characters’ costumes were not restricted (by one time frame). Military details included epaulets, double breasted front, adjustable tabs, breeches, trouser stripe, gun flap, and gaiters.



Figure 19: Lewis, Jess. The new costume designer. Studio “War wall” collage (2018)

Fabrics

Having digital costumes means that the cost of fabric is not as big of a factor and only one copy of each version of the costume would need to be made, where it is common to have multiple copies of a costume, just in case one gets damaged. Although the garments for these characters would be digital, it is still important to consider the fabrics that would be used if these were real characters, to give an accurate digital representation of the garment.

Camouflage can be used to help an attacker blend into the background (Craik, 2005). The koloss are large and blue so for this reason I chose to use various tones of greys so that they could blend in with the ash covered lands. Using grey will also disguise the staining from fallen ash and keeping the uniform looking tidy.

In *The Final Empire* plants are unable to grow properly due to the ash fall, although some nobleman men have small gardens within their houses. It is mentioned that the city Chakath's major export is wool (Sanderson, 2006). In my imagined scenario, The Lord Ruler is purchasing wool from Chakath. Wool was one of the earliest fibres to be woven into cloth and is a widely used natural protein fibre (Kadolph, 2007). It is durable (Kadolph, 2007), resilient to wrinkling, hygroscopic, retains heat, repels water and is flame retardant (Kadolph, 2007). These fabric properties would be important for a creature that spends all of their time outside and need garments that need to last a long time. Visual characteristics of wool include its matte appearance and its loft and body (Kadolph, 2007). The body of the fabric helps create structure in the garments while the drape helps with when the garment has been adjusted for smaller sizes and allows the fabric to hang around the body without looking stiff. In photographs the fabrics translate the same way that they do in real life. I have found that the wool fabrics, although matte in appearance, pick up light well which give the fabrics a lot of depth because of the high contrast in the highlights and shadows. Leather has been used as a contrast fabric with the wool. It is a material that is durable and can add character due to the different textures and flaws throughout the hide (Kadolph, 2007). As leather ages, even more character is added. It has been used in areas that may need extra durability or where a turned under edge, that would be needed for a clean finish on a woven fabric, would be too bulky. The leather used is a lighter weight to allow for the garment to be adjusted, especially around the armhole where it is gathered up to fit the small koloss. In areas where I have needed stronger strapping, instead of using a single layer of thicker leather, I have sewn two pieces of lighter leather together which gives the straps a clean, polished finish on both sides. Two of the leathers I have chosen in greys that are similar to the two wools I have used. These colours link the garments back to each other and also gives an aesthetic contrast to the wool. I chose to use a beige coloured leather for the side stripe and over shoulder strap to add contrast while keeping it a subtle, neutral colour.

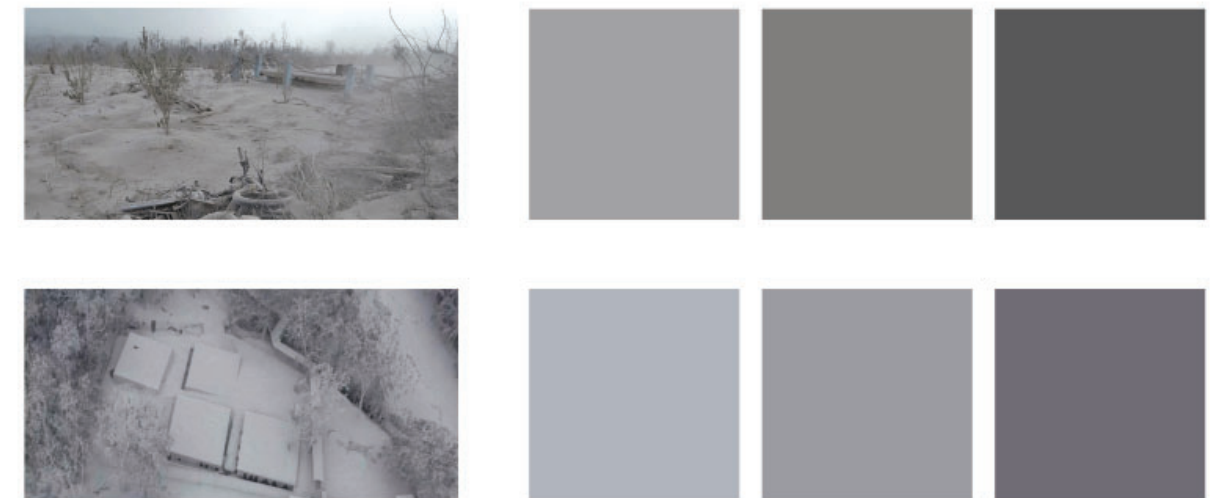

Figure 20: Lewis, Jess. The new costume designer. Workbook page. Colour mood board for ash covered land (2018)

Pattern developments and toiles

The Technology

For this project I had access to one 2D pattern design software, AccuMark Pattern Design and two 3D garment simulation pieces of software; AccuMark V10 3D, an add-on for AccuMark Pattern Design, and CLO, a standalone programme. For a number of reasons I chose to use CLO for the 3D simulation component of this project. Due to AccuMark V10 3D being an early development of the add-on, the usability and interactivity is not at the same level as CLO¹. For a designer to feel comfortable in a 3D environment, the software needs to allow for the user modifying the patterns in a way where they can trial-and-error fit and drape just like they would on a physical mannequin. The best way of providing this is being able to interact between the 2D and 3D screens simultaneously (Magnenat-Thalmann & Volino, 2005), and being able to pick up the fabric and move it in to different places. CLO offers this ability and also enables the option to focus on 2D or 3D, whereas AccuMark V10 3D had separate 2D and 3D workspaces that offered different tools, depending on which workspace you had open. There were also issues around the accessibility and user support for AccuMark 3D. A user must already be an AccuMark client with an up to date license of AccuMark Pattern Design for the 3D add-on to be installed whereas anybody can go onto the CLO website and pay a monthly subscription to have access to the current version. CLO also has video lessons available, allowing users to quickly find a tutorial on how to achieve what they want to. Although you can do patternmaking in CLO and create patterns that would be ready for manufacturing, its focus is on garment simulation meaning it has limited pattern manipulation tools. For this reason, I decided to work between both software, AccuMark Pattern Design and CLO, to take full advantage of the capabilities of each programme.

Throughout my process I used V10 and V11 AccuMark Pattern Design and Model Editor which allows patterns to be created directly on the screen, instead of using traditional paper, pencil, scissors and ruler (Lininger, 2015). A variety of files can be imported and exported into and from Pattern Design which allows users to work within different platforms, I took advantage of this by exporting my patterns from AccuMark as DXF-AAMA files which could then be imported into CLO for 3D visualisation.

I have worked between physical and digital making to create and refine my designs, depending on the complexity of the problem being solved. I utilised the ease and efficiency of drafting and manipulating patterns in PDS, checked basic fit and design in CLO, and experimented with ways the fabric could be manipulated to troubleshoot the problems with bulk on a physical mannequin. My extensive knowledge

¹ This information was correct at the date of testing this software in mid-2017. As this project has progressed, Gerber Technology has acquired Avametric and improved this software. At date of publication it is at V12.

in patternmaking on CAD allowed me to draft all blocks and patterns on Pattern Design, import the patterns into CLO, and then use my knowledge in fit and tailoring to check the fit of blocks and the simple base designs of each garment. Using 3D simulation software for fitting to avatars of the characters gave me an instantaneous view of how the blocks fitted on each size, and where I needed to create adjustment mechanisms for the garments to fit on the two completely different bodies. The ability to work in a digital space allowed me to quickly change a pattern and test basic fixes to see how it affected the fit on each of the bodies without wasting fabric and time sewing a physical sample, only to discover it did not fit correctly. Once I was satisfied with the base designs of each garment, I began to use physical sampling to test adjustment details that were more complex as the way some parts of the garment interacted with itself were not easy to test in a digital space with my skill level. Working in a digital workspace meant that it was easy to work between PDS, CLO, and plot physical patterns at 1/3 scale, to test my ideas on the scaled mannequins. Going between these methods allowed me to take full advantage of the strengths in each of the processes. Later toiles were created in final fabrics as the weight and drape of the fabric made a big difference in how the garment behaved when made at a small scale.

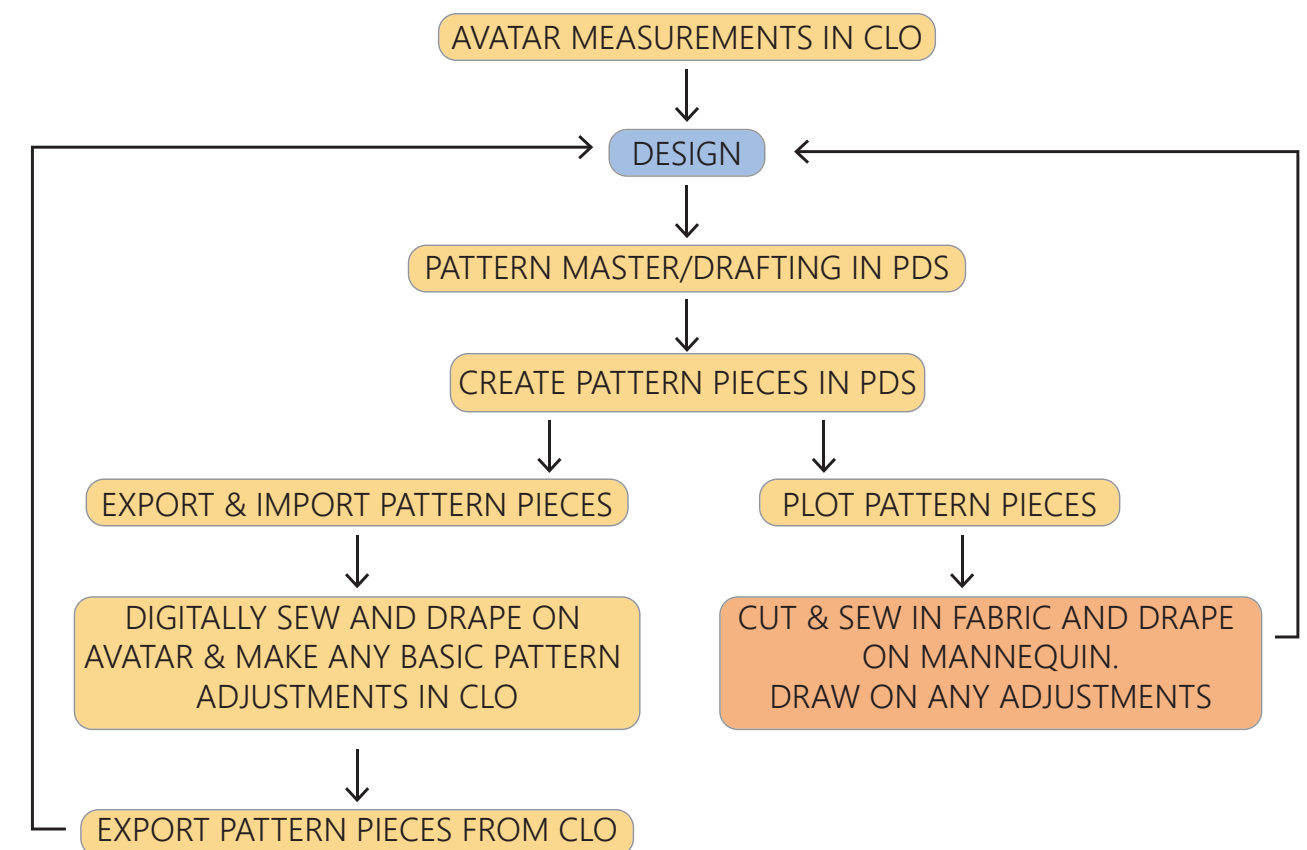

Figure 21: Lewis, Jess. The new costume designer. Pattern and design development workflow (2018).

Toile 1, shirt: Draping on a standard male, 100cm chest, mannequin.



This was a quick test test to play with the placement of the armhole design lines and the fullness in the sleeve, starting to get a feel of how much fullness is needed by draping 3 pleats along the neckline.

Changes to make: The armhole design line continuing over the shoulder to create an anchor for the sleeve, and allows an epaulet to be inserted. Design inspiration taken from harnesses that are worn.

Toile 2, Standard 104cm torso and 84cm tailored trouser block on standard male 100cm chest, and standard child mannequin

While my scale mannequins were still in the process of being made, I wanted to test the general fit difference between two largely different sizes. For this toile I was looking at the body and sleeve length, where extra fabric bulk was happening, design line positioning and sleeve fullness.

This simple exercise helped me see what areas were going to be the biggest problem areas in terms of creating garments to fit two extremely different sizes:

- Lengths of sleeves, legs and body
- Excessive bulk in underarm
- Shoulder length affecting design line placement



Figure 22 (Left): Lewis, Jess. The new costume designer. One-size-fits-all shirt iteration one. (2018)

Figure 23 : Lewis, Jess. The new costume designer. One-size-fits-all shirt iteration two and one-size-fits-all trouser iteration one (2019).

Test: Cuff adjustment

Inspiration came from a french cuff and the way they fold back on themselves. It can be buttoned at different lengths as the arms grow.



Shortest →



→ Longest

Test: Placket openings for trouser

Samples of bound placket and tailored placket to test ways of having openings down the front and back in the middle of the fabric with the adjustable stripes placed ovetop. I used plackets that you would traditionally see for a sleeve opening. It was important that it still looked tidy when the top of the trouser was folded down and you saw the inside of the garment.



I ended up moving the openings to the side seam so the skirt was in two parts, rather than 4. The stripe being on the side is used to show ranking as the koloss grows.

Figure 24 (Left): Lewis, Jess. The new costume designer. Cuff adjustment trial in paper (2019)

Figure 25 (Above): Lewis, Jess. The new costume designer. Workbook sketches and placket opening trials (2019).

Figure 26: Lewis, Jess. The new costume designer. Workbook sketches (2019).

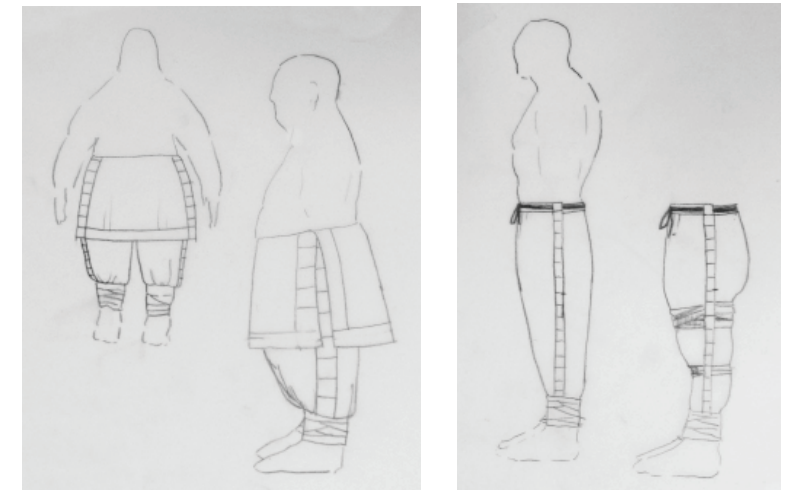

Toile 3a: Drafted blocks on custom avatars.

This toile is similar to toile 2 but is using blocks drafted for the large koloss. This allowed me to see the minimum garment size to fit the large koloss. All extra fabric needed to be manipulated to fit the small koloss. Dressing unusual body shapes made the block drafting process more complex due to the body not being in standard proportions.



Toile 3b, Shirt: Drafted blocks on custom avatars.

With the shirt I decided to also draft a shirt block for the small koloss to have a 2D visual reference for how extremely different the two patterns were and see where the areas of growth were happening.

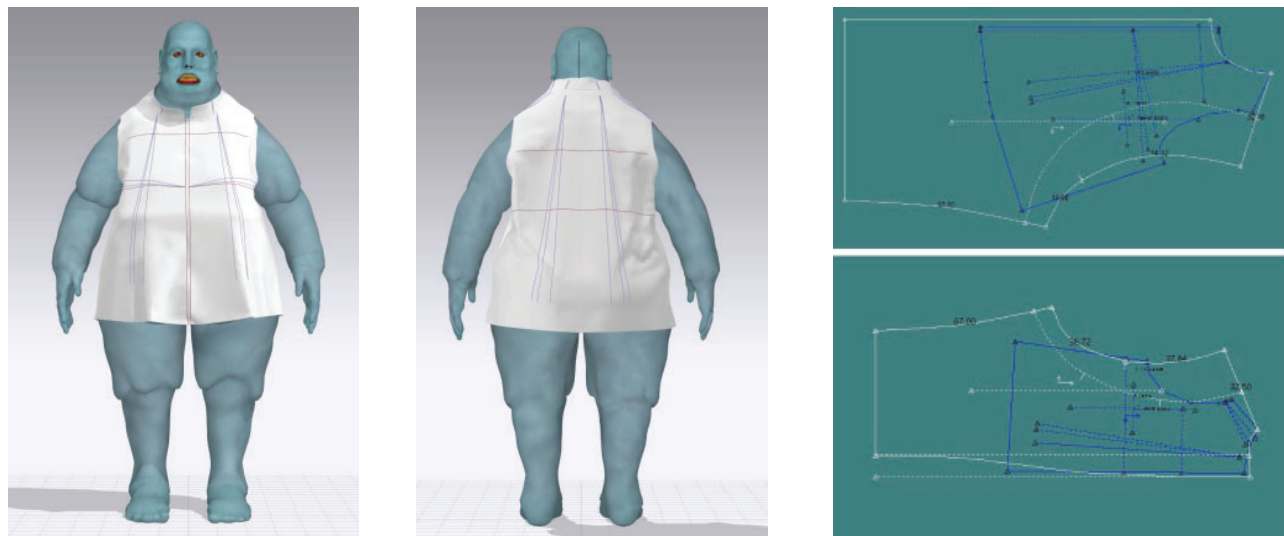

Toile 4, Shirt: Sample of in between base shape

Mechanisms tested:

- Gathering on back neck
- Stand collar
- Single button wrap

Changes needed:

- Could not get onto large koloss without cutting down side seams, need a larger armhole that can be adjusted smaller for the small koloss.
- Sleeve needs to get over bicep muscles on large koloss.
- Shaping needed on lower back while keeping fullness at the top.
- Centre front would be a good point for width adjustment to happen.

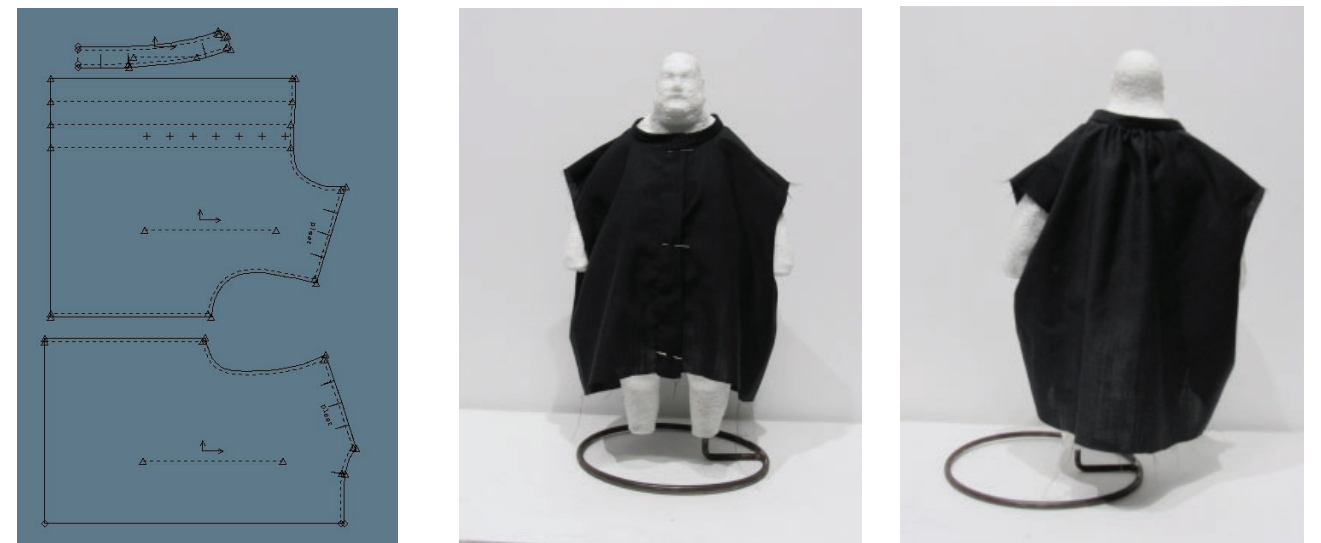

Figure 27 (Top Left): Lewis, Jess. The new costume designer. Drafted shirt and trouser blocks made to the large koloss measurements, draped on avatars in CLO (2019).

Figure 28 (Bottom Left): Lewis, Jess. The new costume designer. Drafted shirt block made to the small koloss measurements, draped on avatar in CLO (2019). PDS screenshot of the two blocks stacked on top of each other (2019)

Figure 29: Lewis, Jess. The new costume designer. Shirt block, inbetween the two sizes on mannequin(2019).

Toile 5a, Shirt: Sample of adjustment mechanisms

Mechanisms tested:

- Double breasted front with buttons and buttonholes
- Gathered sleeve
- Channel with drawstring all the way around armhole
- Underarm gusset with lacing
- Pintucks on lower back

Changes needed:

- Add yoke to stabilise shoulders and add control in the gathering.
- Remove excess from centre back yoke area and change excess on centre back to a pleat.
- Change channel from fabric to leather and widen.
- Add sewn-in epaulettes.
- Lengthen body.
- Shorten pin tucks.
- Remove underarm gusset completely and add extra in the armhole.
- Change sleeve gathering to three pleats.

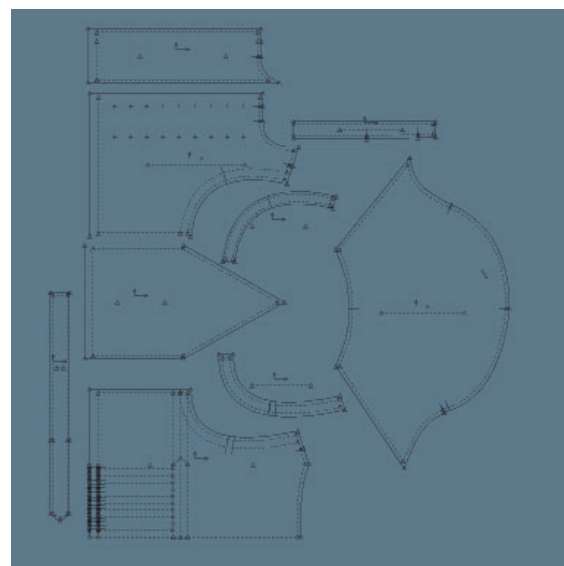

Figure 30: Lewis, Jess. The new costume designer. One-size-fits-all shirt iteration three patterns on PDS (2019).



Figure 31: Lewis, Jess. The new costume designer. One-size-fits-all shirt iteration three workbook sketches and toile on mannequins (2019).

Toile 5b, Trouser: Sample of adjustment mechanisms

Mechanisms tested:

- Dropped crotch line to account for folding the top half back over itself.
- Fly opening with single adjustment stripe over top.
- Back waist darts
- Front waist pleats

Changes needed:

- Shorten crotch line.
- Double adjustment stripe for stability and keeping the back in place.
- Shorten length, make it a long short on the large koloss and full length on small koloss.
- Slim the hem.
- Controlled adjustment needed on the lower leg.
- Remove back darts OR add lining, to create a smooth inside when turned down on small koloss.

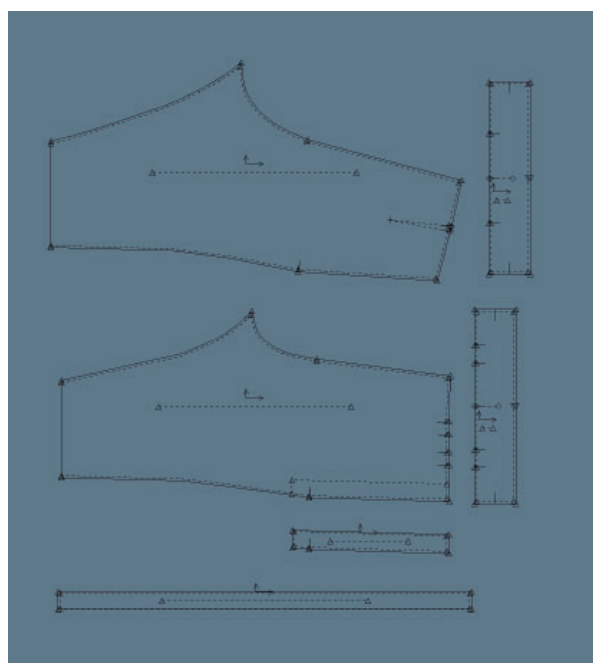

Figure 32: Lewis, Jess. The new costume designer. One-size-fits-all trouser iteration two patterns on PDS (2019).



Figure 33: Lewis, Jess. The new costume designer. One-size-fits-all trouser iteration two workbook sketches and toile on mannequins (2019).

Toile 6a, Shirt: Refinement of adjustment mechanisms

Mechanisms tested:

- Fused yoke with two pleats on back.
- Leather channels with leather drawstrings.
- Pleated sleeve.
- Adjustable sleeve cuff.
- Adjustable length, folding back on itself

Changes needed:

- Collar shaping; too narrow to be sewn into place without cutting off the whole seam allowance.
- Add panel line around body and insert a strap to control the length. Inspired by harness shaping.
- Add a few more pin tucks.
- Add extra width on cuff.
- Add extra buttonhole on centre of cuff so the small koloss can button it on to epaulette .

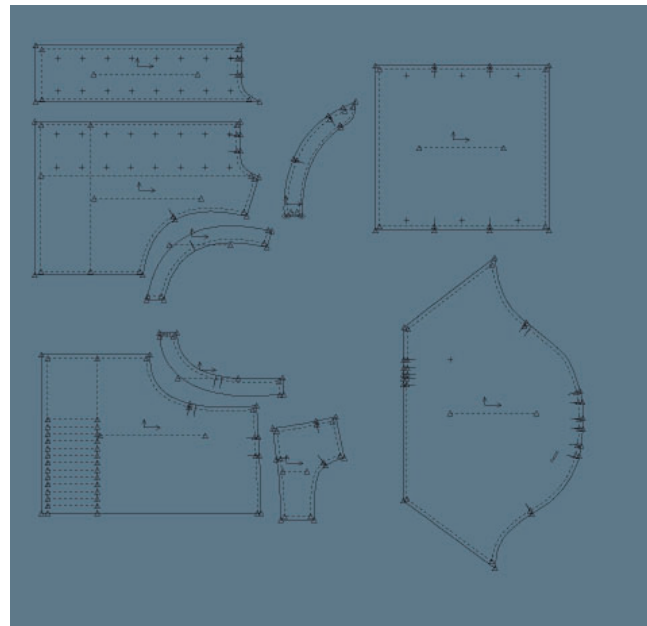

Figure 34: Lewis, Jess. The new costume designer.
One-size-fits-all shirt iteration four patterns on PDS (2019).



Figure 35: Lewis, Jess. The new costume designer.
One-size-fits-all shirt iteration four workbook sketches and toile on mannequins (2019).

Toile 6b, Trouser

Mechanisms tested:

- Shorter length.
- Double stripe on side seam.
- Added lower leg lacing: Outer leg and inner leg.
- Iteration on inner lower leg lacing with extra strap around lower thigh.
- Front pleats removed and folded once.

Changes needed:

- Add pintucks along lower leg.
- Revert back to single stripe on side seam and add buttons/buttonholes on top half to keep both sides together.

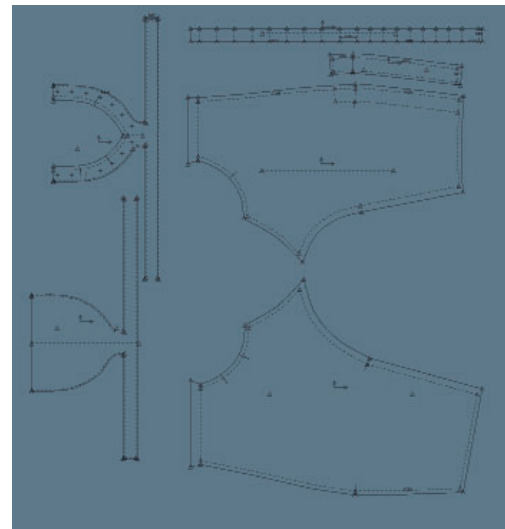
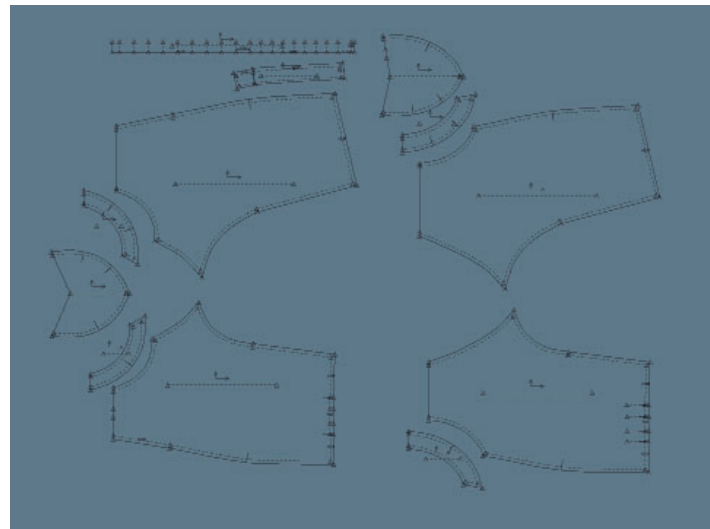

Figure 36: Lewis, Jess. The new costume designer. One-size-fits-all trouser iteration three patterns on PDS (2019).

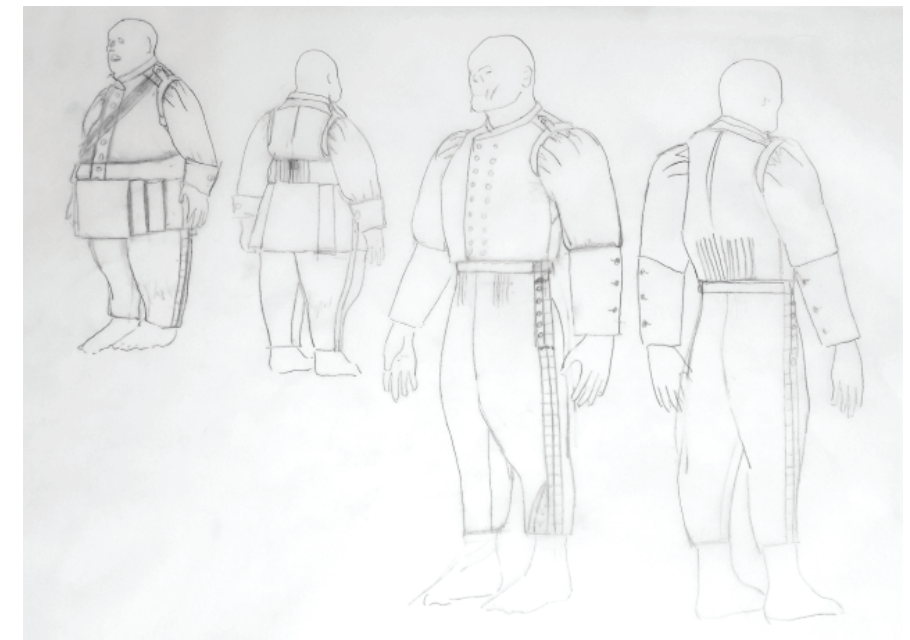
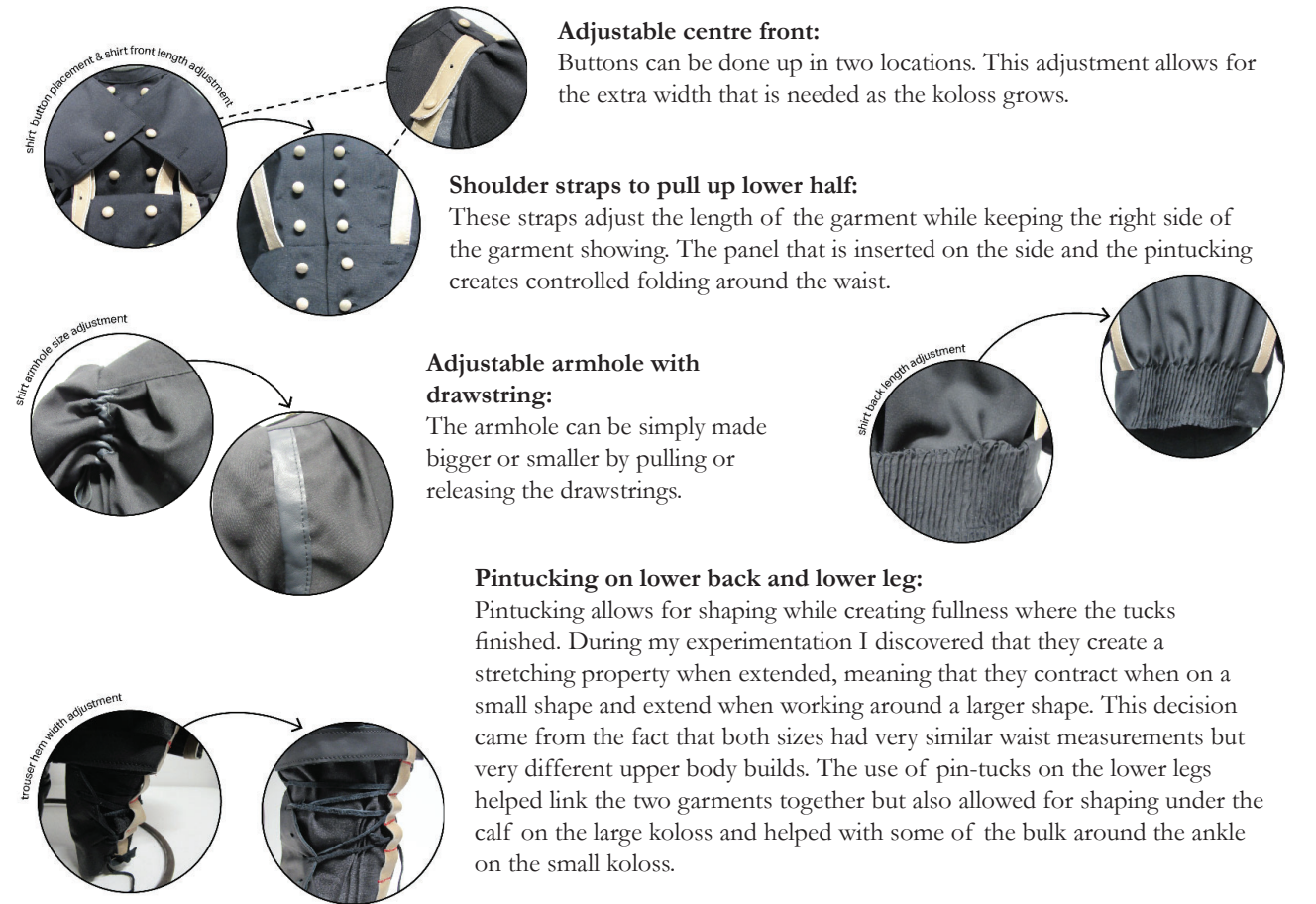

Figure 37: Lewis, Jess. The new costume designer. One-size-fits-all trouser iteration three workbook sketches and toile on mannequins (2019).

Final garments- Front



Final garments- Back



Adjustable centre front:
Buttons can be done up in two locations. This adjustment allows for the extra width that is needed as the koloss grows.

Shoulder straps to pull up lower half:
These straps adjust the length of the garment while keeping the right side of the garment showing. The panel that is inserted on the side and the pintucking creates controlled folding around the waist.

Adjustable armhole with drawstring:
The armhole can be simply made bigger or smaller by pulling or releasing the drawstrings.

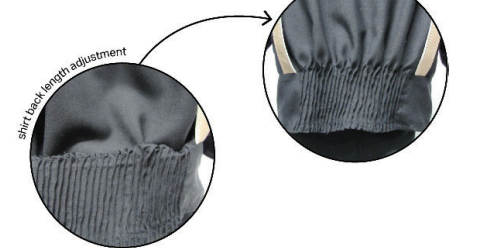

Pintucking on lower back and lower leg:
Pintucking allows for shaping while creating fullness where the tucks finished. During my experimentation I discovered that they create a stretching property when extended, meaning that they contract when on a small shape and extend when working around a larger shape. This decision came from the fact that both sizes had very similar waist measurements but very different upper body builds. The use of pin-tucks on the lower legs helped link the two garments together but also allowed for shaping under the calf on the large koloss and helped with some of the bulk around the ankle on the small koloss.

Lower leg lacing and thigh strap:
The lacing can be tightened or loosened to fit the lower leg. The panel on the inner leg gives the lacing an anchoring point and gives a little bit more extension if needed. The strap at the top of the panel can be used to put pressure on skin that has torn apart above the knee.

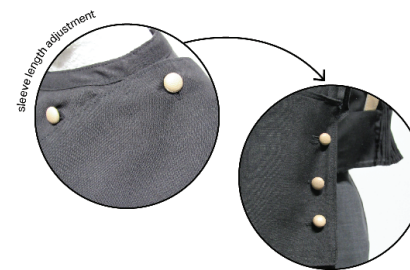

Adjustable sleeve cuff:
The cuff can be worn two ways; buttoned to the epaulette, which is compulsory for the small koloss due to the length of the sleeve, or the cuff could be button together like a french cuff at a variety of lengths.



Adjustable side seam stripe with buttons and buttonholes:
Strapping can be threaded through the loops at various heights. If it is threaded at the lowest position, which is at the loop below the opening, the skirt falls over itself and creates a skirt shape over top of the trouser. Moving the strapping to higher loops will shorten the skirt, eventually becoming a paper bag waist and then flat tailored trousers. As the strapping is moved upwards, buttons can be done up to hold the front and back together. This mechanism is also used to show age and status; as they grow, more of the single stripe, red lines and buttons is shown.

Figure 38: Lewis, Jess. The new costume designer. One-size-fits-all final shirt and trouser draped on mannequins with details of adjustments. (2019)

Reflections

This practice-led project explored the integration of digital technologies for physical costume design and making in film. It presented me with opportunities to gain more grounded knowledge about the local, New Zealand film industry through talking to industry experts about their experiences. These began reflection about the changing nature of the industry, where it is becoming more common for DCCAs to engage a traditional costume designer for costumes that are CGI.

Costume designers working in both physical and digital spaces gives flexibility in the way that digital patterns and assets can be used. They could be passed on to a physical workshop, where patterns are plotted, fabric cut and manually sewn into physical costumes for an actor, or passed on to an animation studio to create digitally sewn costumes for computer-generated characters. Having the 2D patterns created by someone who understands patternmaking guarantees that the patterns work in a real-life scenario. A patternmaker who also has 3D cloth simulation experience can digitally sew the final 2D digital patterns together before handing the assets to an animation team which eliminates guesswork by someone who does not have patternmaking and garment construction experience. The patternmaker, who would also be trained in garment construction and fit, should be able to see fit issues easily within the digital space, resulting in less frustration by DCCAs who may be unable to work out why the drape and fit is incorrect. Both departments could be using software created by CLO Virtual Fashion Inc. but with different focuses, Marvelous Designer for digital FX and CLO for fashion, and could easily share files between the two. If the patternmaker can get the process started, they can then pass on patterns and virtually sewn garments to the DCCA to make their job easier and allows them to focus on the visual representation of fabrics, details, lighting and how the garment interacts with the avatar.

Throughout the technical design exploration of my costume for a fantasy character I utilised both physical and digital methods of making for a one-size-fits-all uniform. Physical methods comprised of drawing and garment construction and digital methods were AccuMark PDS for block and pattern development, and CLO for fit adjustments and checking design lines. I chose each of these processes to take advantage of the possibilities within them.

The restriction of a one-size-fits-all uniform meant that I needed to think about how the fabric could be manipulated to be made smaller or larger to fit the full range of koloss. This created a complex garment that was hard to pattern and sample in CLO. Even though I sit comfortably in a digital space for 2D patternmaking, due to these complexities, the combination of my basic 3D simulation skills for

CLO, and the software's capabilities of working with a lot of fabric I could not successfully sample the designs.

These complexities combined with using an exaggerated body shape, made working on a scale mannequin necessary for this project to test the mechanisms and see how the fabric reacted. Working on a full scale mannequin was not possible due to the size of the koloss. Working at scale made some of the smaller details (like the pintucks) harder, although not impossible, to execute. Seam allowances had to be calculated and modified so it was realistic to be able to sew the scaled garments but still have the seam allowances look like they belong to the full scale and 1/3 scale garments. The experience of working on these scaled mannequins taught me the importance of choosing the right scale to work at and if I was to repeat the process, I would explore the option of having them created at 1/2 scale. The advantages of working in a physical workspace became apparent for accurately working out these more complex sizing adaptations and manipulations. On saying that the advantage of a digital workspace allowed for quick pattern manipulation, quickly test fit of blocks and design lines, and meant that I could work at full scale to dress the avatar or plot at scale to dress the mannequin. With the rise of CGI in film, and the demand for accurate digital costumes, costume designers who can work between physical and digital processes and workspaces will have the opportunity to step into the expanding costume designer role. Knowledge of digital and physical processes can enhance communication between departments and integrated skill sets.

The research and design development throughout this project has stretched my abilities as a traditionally trained fashion designer. Not only did it give me a deeper understanding about costume design for film but also allowed me to explore processes for adaptive sizing for inclusive design which has become increasingly important in the fashion industry. Just as digital technologies can be used to dress fantastical bodies in film, it can be used to diminish standardised sizing in fashion through individual size customisation.

Bibliography

- Aldrich, W. (2008). *Metric Pattern Cutting for Women's Wear* (5th ed.): Blackwell Publishing Ltd.
- Aldrich, W. (2011). *Metric Pattern Cutting for Menswear* (5th ed.): Wiley.
- Aldrich, W. (2015). *Metric Pattern Cutting for Women's Wear* (6th ed.): Wiley.
- Carman, W. Y. (1977). *A dictionary of military uniform*. London: Scribner.
- Castonguay, J. (2016). The Modern Entertainment Marketplace, 2000–Present. In A. L. McLean (Ed.), *Costume, Makeup, and Hair* (pp. 149-174). New Brunswick, NJ: Rutgers University Press.
- Choi, K.-J., & Ko, H.-S. (2005). Research problems in clothing simulation. *Computer-Aided Design*, 37(6), 585-592. 10.1016/j.cad.2004.11.002
- Craik, J. (2005). *Uniforms exposed: from conformity to transgression*. Oxford: Berg.
- Croonborg, F. T. (2005). *Blue Book of Men's Tailoring: Grand Edition of Supreme System For Producing Men's Garments (1907)*.
- Davis, B. L. (1983). *British Army uniforms & insignia of World War Two*. London: Arms and Armour Press.
- Failes, I. (2019). Super misfits: The VFX of The Umbrella Academy. Retrieved 10th June 2019 from <http://vfxvoice.com/super-misfits-the-vfx-of-the-umbrella-academy/>
- Fordham, J. (2019). Iron Maiden. *Cinefex*(163), 13-35.
- Gray, S. (1998). *CAD/CAM in clothing and textiles*. Hampshire, England: Gower Publishing Limited.
- Hedgpeth, K., & Missal, S. (2006). *Exploring character design*. NY: Thomson Delmar Learning.
- Interviewee, A. (2018, 18th November). [Interview with Interviewee A].
- Interviewee, C. (2019). Interview with Interviewee C.
- Johnston, J. (2012). The challenges of Mocap and CGI. In D. N. Landis (Ed.), *Hollywood Costume* (pp. 294-306). London: V&A Publishing.
- Joseph-Armstrong, H. (2010). *Patternmaking for Fashion Design* (5th ed.). New Jersey: Pearson Prentice Hall.
- Kadolph, S. J. (2007). *Textiles* (10th ed.). New Jersey: Pearson Prentice Hall.
- Kang, Z. Y., Cassidy, T., Cassidy, T., & Li, D. (2015). *Historic Costume Simulation and its Application*. Paper presented at the 15th Autex World Textile Conference 2015, Bucharest, Romania.
- Kannik, P. (1968). *Military Uniform in Colour*. London: Blandford.
- Kim, D.-E., & LaBat, K. (2013). An exploratory study of users' evaluations of the accuracy and fidelity of a three-dimensional garment simulation. *Textile Research Journal*, 83(2), 171-184.
- Kim, S., & Ko, Y.-A. (2015). *A Study on the Utilization of 3D Virtual Clothing Programs by Baby Clothes Manufacturers*. Paper presented at the Digital Fashion Conference, Seoul, Korea.
- Kuzmichev, V., Moskvina, A., & Moskvina, M. (2018). Virtual Reconstruction of Historical Men's Suit. *Autex Research Journal*, 18(3)
- Kuzmichev, V., Moskvina, A., Surzhenko, E., & Moskvina, M. (2017). Computer reconstruction of 19th century trousers. *International Journal of Clothing Science and Technology*, 29(4), 594-606.
- Lininger, M. (2015). *Patternmaking and Grading: Using Gerber's AccuMark Pattern Design Software*. New Jersey: Pearson Education, Inc.
- Magnenat-Thalmann, N., & Volino, P. (2005). From early draping to haute couture models: 20 years of research. *The Visual Computer*, 21, 506-519.
- Nadoolman Landis, D. (2007). *Dressed: A century of Hollywood costume design*. New York: HarperCollins Publishers.
- Prince, S. (2012). *Digital visual effects in cinema: The seduction of reality*. Piscataway, NJ: Rutgers University Press.
- Robertson, B. (2019). Calling the Ape Experts: How Dr. Pogo from Netflix's The Umbrella Academy Was Created. Retrieved 10th June 2019 from <http://www.studiodaily.com/2019/05/umbrella-academy-vfx-supervisor-everett-burrell-weta-digital-dr-pogo/?fbclid=IwAR3mtRnz4FhWUkMc-q2v2sow3LhjRLX5ec6c7o9WdHKCI8h6uSpwmG2g2dAQ>
- Sanderson, B. (2006). *Mistborn: The Final Empire*. Orion Publishing Group.
- Sanderson, B. (2007). *Mistborn: The Well of Ascension*. Orion Publishing Group.
- Sanderson, B. (2008). *Mistborn: The Hero of Ages*. Orion Publishing Group.
- Seo, D. (2018). Addressing Resistance to 3D Virtual Prototyping in Apparel Design and Product Development Retrieved 18/08/2018 from <https://www.clo3d.com/company/newsdetail/86>
- Shep, R. L. (1998). *The Great War: styles and patterns of the 1910s*. Mendocino, CA: R.L. Shep.
- Siersema, I. (2015). *The influence of 3D Simulation technology on the fashion design process and the consequences for higher education*. Paper presented at the Digital Fashion Conference, Seoul, Korea.
- Swann, C. (2002). Action Research and the Practice of Design. *Design Issues*, 18(1), 49-61.
- Volino, P., & Magnenat-Thalmann, N. (2000). *Virtual Clothing: Theory and Practice*. Springer-Verlag Berlin Heidelberg.
- Zakarin, J. (2019). Weta and netflix built Umbrella Academy's Pogo with new tech, ape models, and great tailors. Retrieved 10th June 2019 from <https://www.syfy.com/syfywire/weta-and-netflix-built-umbrella-academys-pogo-with-new-tech-ape-models-and-great-tailors?fbclid=IwAR114P->

List of figures

Figure 1

Processes and roles within the film industry. Image by Jess Lewis (2018).

Figure 2

Results of data gathered from interviews and surveys. Image by Jess Lewis (2019)

Figure 3

Volino, P., & Magnenat-Thalmann, N. (2000). *Virtual Clothing: Theory and Practice*. Springer-Verlag Berlin Heidelberg.

Figure 4

Volino, P., & Magnenat-Thalmann, N. (2000). *Virtual Clothing: Theory and Practice*. Springer-Verlag Berlin Heidelberg.

Figure 5

CGI Pogo in digital costume. Credit: Netflix Retrieved from: Zakarin, J. (2019). Weta and netflix built Umbrella Academy's Pogo with new tech, ape models, and great tailors. Retrieved 10th June 2019 from <https://www.syfy.com/syfywire/weta-and-netflix-built-umbrella-academys-pogo-with-new-tech-ape-models-and-great-tailors?fbclid=IwAR114PPIGeqNjWe9CBuf179dTzZghopvD9fPImgVbFwgzRICH5-AXYxvdk>

Figure 6

CGI Alita in digital costume. Credit: 20th Century Fox (2019) retrieved from: <https://www.foxmovies.com/movies/alita-battle-angel>

Figure 7

Workbook page: Collage/mood board (2017) Illustrations retrieved from:
Koloss: Inkthinker, The works of Ben McSweeney: Mistborn. <http://www.inkthinker.net/illustration.php>
The Lord Ruler, credit Ben McSweeney: The Coppermind: Rashek <https://coppermind.net/wiki/Rashek>

Figure 8

Hedgpeth, K., & Missal, S. (2006). *Exploring character design*. NY: Thomson Delmar Learning.

Figure 9

Workbook page: Breaking down the character “Koloss”. Image by Jess Lewis (2017)

Figure 10

Workbook page: Sketching “Koloss”. Image by Jess Lewis (2018)

Figure 11

Personal communication with Cameron Doidge (2018)

Figure 12

Final avatars in CLO. Image by Jess Lewis (2018)

Figure 13

Final avatars with bounding volumes and arrangement points in CLO. Image by Jess Lewis (2018)

Figure 14

Aldrich, W. (2011). *Metric Pattern Cutting for Menswear* (5th ed.): Wiley.

Final avatars with points of measurement in CLO. Image by Jess Lewis (2018)

Figure 16

Personal communication with Cameron Holder (2019)

Figure 17

Process images of preparing the mannequin: sticking the two halves together and cutting away excess areas. Image by Jess Lewis (2019)

Figure 18

Final mannequins on stands. Image by Jess Lewis (2019)

Figure 19

Studio “War wall” collage. Image by Jess Lewis (2018)

Images retrieved from:

Carman, W. Y. (1977). *A dictionary of military uniform*. London: Scribner.

Davis, B. L. (1983). *British Army uniforms & insignia of World War Two*. London: Arms and Armour Press.

Kannik, P. (1968). *Military Uniform in Colour*. London: Blandford.

Shep, R. L. (1998). *The Great War : styles and patterns of the 1910s*. Mendocino, CA: R.L. Shep.

Figure 20

Workbook page. Colour mood board for ash covered land. Image by Jess Lewis (2018)

Images retrieved from:

<https://qz.com/1296646/fuego-volcano-blankets-guatemalas-landscape-in-ash-in-photos/>

<https://www.mrfixitbali.com/natural-disasters/volcanic-ash-253.html>

Figure 21

Pattern and design development workflow. Image by Jess Lewis (2018)

Figure 22

Garment iteration. Image by Jess Lewis (2018)

Figure 23

Garment iteration. Image by Jess Lewis (2019)

Figure 24

Cuff adjustment trial in paper. Image by Jess Lewis (2019)

Figure 25

Workbook sketches and placket opening trials. Image by Jess Lewis (2019)

Appendices

Figure 26

Workbook sketches. Image by Jess Lewis (2019)

Figure 27

Block toiling. Image by Jess Lewis (2019)

Figure 28

Block toiling. Image by Jess Lewis (2019)

Figure 29

Block toiling. Image by Jess Lewis (2019)

Figure 30

Garment PDS patterns. Image by Jess Lewis (2019)

Figure 31

Workbook sketches and garment iteration. Image by Jess Lewis (2019)

Figure 32

Garment PDS patterns. Image by Jess Lewis (2019)

Figure 33

Workbook sketches and garment iteration. Image by Jess Lewis (2019)

Figure 34

Garment PDS patterns. Image by Jess Lewis (2019)

Figure 35

Workbook sketches and garment iteration. Image by Jess Lewis (2019)

Figure 36

Garment PDS patterns. Image by Jess Lewis (2019)

Figure 37

Workbook sketches and garment iteration. Image by Jess Lewis (2019)

Figure 38

Final garments. Image by Jess Lewis (2019)

Table 1

Chart of Standard points of measurements vs small koloss vs large koloss. Image by Jess Lewis (2018)

Aldrich, W. (2011). *Metric Pattern Cutting for Menswear* (5th ed.): Wiley.

humanethics@massey.ac.nz

Thu 16/8/18 2:18 PM

To: [REDACTED]; Caroline.Campbell.8@uni.massey.ac.nz
<Caroline.Campbell.8@uni.massey.ac.nz>; D.M.Cumming@massey.ac.nz <D.M.Cumming@massey.ac.nz>;
T.Marriott@massey.ac.nz <T.Marriott@massey.ac.nz>
Cc: humanethics@massey.ac.nz <humanethics@massey.ac.nz>

HoU Review Group

Ethics Notification Number: 4000019839

Title: The new costume designer: An exploration of digital design technologies for made-to-measure (MTM) costumes in a computer-generated world.

Thank you for your notification which you have assessed as Low Risk.

Your project has been recorded in our system which is reported in the Annual Report of the Massey University Human Ethics Committee.

The low risk notification for this project is valid for a maximum of three years.

Please note that travel undertaken by students must be approved by the supervisor and the relevant Pro Vice-Chancellor and be in accordance with the Policy and Procedures for Course-Related Student Travel Overseas. In addition, the supervisor must advise the University's Insurance Officer.

A reminder to include the following statement on all public documents:

"This project has been evaluated by peer review and judged to be low risk. Consequently it has not been reviewed by one of the University's Human Ethics Committees. The researcher(s) named in this document are responsible for the ethical conduct of this research.

If you have any concerns about the conduct of this research that you want to raise with someone other than the researcher(s), please contact Professor Craig Johnson, Director (Research Ethics), email humanethics@massey.ac.nz. "

Please note that if a sponsoring organisation, funding authority or a journal in which you wish to publish require evidence of committee approval (with an approval number), you will have to complete the application form again answering yes to the publication question to provide more information to go before one of the University's Human Ethics Committees. You should also note that such an approval can only be provided prior to the commencement of the research.

You are reminded that staff researchers and supervisors are fully responsible for ensuring that the information in the low risk notification has met the requirements and guidelines for submission of a low risk notification.

If you wish to print an official copy of this letter, please login to the RIMS system, and under the Reporting section, View Reports you will find a link to run the LR Report.

Yours sincerely

Professor Craig Johnson
Chair, Human Ethics Chairs' Committee and
Director (Research Ethics)



MASSEY UNIVERSITY
COLLEGE OF CREATIVE ARTS
TOI RAUWHĀRANGI

Private Box 756
Wellington
New Zealand
T 64 4 801 279
www.massey.ac.nz

The new costume designer: An exploration of digital design technologies for made-to-measure (MTM) costumes in a computer-generated world.

INFORMATION SHEET

You are invited to participate in an interview/discussion that will form part of the above research project. This practice-led project will explore the use of digital design technologies for costumes created in a digital space and asks the question "How do digital and physical technologies fit in to the industry of costume design?"

Participant Identification

Participants for this part of the research have been identified through professional contacts.

Project Procedures

This will involve taking part in interview/discussion of approximately 30-45 minutes duration, at a time and place that will be arranged.

Data Management

The conversation will be recorded and transcribed by the researcher. Digital audio and transcription files will be kept by the researcher in a secure location for 5 years, and then destroyed.

Participant's Rights

If you participate, you have the right to:

Decline to answer any particular question;

Withdraw from participating at any time;

Ask any questions about the study;

Provide information on the understanding that your name and company will not be used;

Ask for the audio recording to be turned off at any time during the conversation;

Project Contacts

You are invited to contact the researcher at any time, if you have any questions about the project.

Jess Lewis
Master of Design Candidate
College of Creative Arts
Massey University
Wellington
Email: [REDACTED]
Ph: [REDACTED]

This project has been evaluated by peer review and judged to be low risk. Consequently it has not been reviewed by one of the University's Human Ethics Committees. The researcher named in this document is responsible for the ethical conduct of this research. If you have any concerns about the conduct of this research that you want to raise with someone other than the researcher, please contact Professor Craig Johnson, Director (Research Ethics), email humanethics@massey.ac.nz

The new costume designer: An exploration of digital design technologies for made-to-measure (MTM) costumes in a computer-generated world.

PARTICIPANT CONSENT FORM - INDIVIDUAL

I have read the Information Sheet and have had the details of the study explained to me. My questions have been answered to my satisfaction, and I understand that I may ask further questions at any time.

I agree/do not agree to the interview being sound recorded.

I agree to participate in this study under the conditions set out in the Information Sheet.

Signature: Date:

Full Name - printed

(Appendix C)

Interview with Interviewee A,

18th November, 2018

1a. When thinking about your job in the area of costume for film which space do you currently sit within?

Physical- I design and/or make costumes for physical actors

1b. Do you work in:

Concept Design

Production/Fabrication

1c. What area did you train in?

Self-taught

Industry-taught

2a. What is your level of experience in the film industry (no. of years)

11

2b. Can you briefly describe what your job comprises of (paragraph):

Head of textiles. Day to day running and interaction with clients, team and team leaders. Teaching the making to team.

2c. When thinking about your current employment do you work:

In a team within a company 100+

3a: In your workplace, do you get the opportunity to work between different departments or companies?

Yes

3b: If yes, what kinds of companies and/or departments do you go between? And why?

Collaborating with the 3D department, our 3D department does 3D modelling printing, that sort of thing. Paint department, armoury department, props, pretty much every department.

3c: If no, what kinds of companies and/or departments would you like to go between? And why?

N/A

4a: Can you describe the nature of collaboration between different practitioners, departments or companies in relation to authenticity for the design and making of physical and digital costumes?

These days, of course, more and more costumes are digitized, regardless of whether it's a heavily CG film or not, they do tend to scan the performers. So, that is definitely something that is part of my job more and more with each job that we do. So specifically between costume and the digital side, that comes down to creating examples of materials, that is probably the biggest one, providing samples of materials and how they function, how they move and flow, that sort of thing. On a daily basis we also collaborate with the different departments, so that involves creating components that go into costumes, just everything, it's such an integral part of what we do.

It's such an ever involving thing, every time we do something, it just informs how we would do it the next time and of course, because the technology changes at the same rate, there is never any set guidelines.

[In reference to CLO3d/Marvelous Designer software] I've never used it myself but a couple of our concept artists do, so it was really interesting to see what they do with it and how we could inform what they do by teaching them about traditional patternmaking...Often times it will be done there and then at some point you might get a chance to say 'Hang on a second, that's not how that would work.'

4b. Through your experiences, how do physical fabrication practitioners/departments/ companies communicate with digital practitioners/departments/ companies and what is the full process?

Most of the time we don't interact with the digital teams at all, which is a real pain, when we do get to, it creates a better product all around. When we do get that chance to integrate the physical with the digital, it's fantastic and it's a fascinating process...which depends on every film that you are on.

The way it would work these days would be feeding them a finished costume. The main interaction we get currently is on set. The actor, wearing a costume, would be scanned on set, just the full turn around, that sort of thing. That would be the extent of our interaction, everything else from there on is taken on by them...They take a lot of photos, all of that would be done on their side. You can put a lot of hard work in to a physical thing but I think the idea of doing samples is probably the more versatile way of doing things rather than a 100% finished garment that encompasses every part of it.

[In response to my comment: As garment designers, we probably pick up on all the little details, whereas an animator wouldn't necessarily pick up all the little details so those little samples helps them find those details] Exactly, you can look at really shabby digitally animated clothing and it moves wrong, everything about it is wrong, it creases in weird ways, but that is something that unless have that knowledge, they don't know and they don't care, they don't have time to care.

I would love to see more cross over, even if it is just a closer integration and collaboration between the two departments.

4c. What systems and technologies of design and making would make this process easier?

Interestingly, we have started using a project management software that I think is mainly used in the digital animation world. So that has been interesting to see what that pipeline is. That sort of thing, if you could collaborate between the companies would be amazing but often that's just completely not going to happen.

4d. What systems and technologies of design and making would you like to learn?

I'd love to learn more about it, but no time. I'd love to have a better understanding of just basic software like Zbrush, Maya, just really basic understanding so I can express what I need to, in the language they understand. Plus Zbrush is amazing, so great for just creating components. It's so powerful, there is so much you can do, and it's a software that we use a lot.

4e. What practitioners/ departments/companies would you like to collaborate with?

I'd like to collaborate with as many as I can because everything you do and everywhere you go, they do something differently and it's really cool to learn what they do. I couldn't narrow that down.

5a. Within the costume design and making process, do you feel digital technologies are relevant?

Yes, absolutely, 100%

5b. Within the costume design and making process, do you believe it is important to be exploring digital technologies further?

Absolutely

5c. In your experience, what are current limitations in digital and physical technologies within the costume design and making process?

The only real limitation is time, to be able to understand more of the particular technology and software that's available because the possibilities are endless. If you can figure one thing out, you can figure out the

next. I don't think that there are any limitations yet other than time. Time to learn, time to do it and time for the physical making.

5d. Within the costume design and making process, where do you think the innovation of technology is going in the industry (From digital patternmaking, Made-to-Measure to Digital Simulation), where would you like to see it head? And what would you like to see the next generation of costume designers learning?

I think that there's a huge amount of scope for digital patternmaking and also digitally manipulating materials that we work with whether that's printing or 3D printing on to (Fabric) or 3D printing the actual materials, impregnating, everything. Incorporating it into traditional techniques as well so weaving, it's just endless.

Made-to-measure, I think there's is a fair way to go until that's affordable for the end user. When it comes to the digital side, particularly 3D scanning the body, that sort of thing, it's easily available but I don't think it's quite there yet and it's costly...For the standard person at home, wanting to do that, it's pretty pricey but it's getting there. We basically just work with milled mannequins from 3D scans.

Q. What would you say are the limitations with that?

Because it's a scan, it's essentially just a silhouette so it doesn't account for the fact that bodies squish, if they have thick hair then it's scanning the hair, so there is still limitations there but it's still a really amazing tool, all the 3D technologies are really awesome tools at this point. 3D scans are great but they are always sort of like this statue [A-pose] which doesn't help when there are so many things that change on bodies depending on rotation of limbs, so you do have to have a really good understanding if bodies in a traditional patternmaking sense in order to maximise the use of 3D mill.

I would also like them (The next generation of costume designers) to not lose the focus of the importance of traditional techniques. If you don't understand how fabric physically works, then it's just never really going to ever look the same way. You don't have to be good at it, but you should understand the theory.

(Appendix D)

**Interview with Interviewee B,
1st November, 2018**

1a. When thinking about your job in the area of costume for film which space do you currently sit within?

Physical

1b. Do you work in:

Production/Fabrication

1c. What area did you train in?

Fashion Design

Self-taught

Industry-taught

2a. What is your level of experience in the film industry (no. of years)

7 years on and off

2b. Can you briefly describe what your job comprises of (paragraph):

I'm usually brought on as a machinist so they will usually cut out the garments and then I put it together. Problem solving in the construction area.

2c. When thinking about your current employment do you work:

In a team in a company 50-100

3a: In your workplace, do you get the opportunity to work between different departments or companies?

No. I've worked for [Company A] which is the production facility for the film itself, that's based on site of where they are filming and then [Company B] is a contractor to the film production company.

3b: If yes, what kinds of companies and/or departments do you go between? And why?

N/A

3c: If no, what kinds of companies and/or departments would you like to go between? And why?

N/A

4a: Can you describe the nature of collaboration between different practitioners, departments or companies in relation to authenticity for the design and making of physical and digital costumes?

There are different approaches in the companies: [Company A] what I normally see, there would be a drawing or a picture, often generated by the art department, of the costume and then [the pattern cutter] would make the pattern then we'd toile it, check the proportions were right, that it was looking right then make it up in the choice of fabric after having the fabric approved by the designer. Once it was made up they would do a film check just to check that it looked and moved the way they wanted it.

At [company B] the head pattern cutter would have the design photos and pictures and she would pattern cut and it would be toiled. Then the designer and her would look at the fit and then go from there and adjust it. It would then come down the line and get the different pieces done on the finished garment so there wasn't any collaboration at all.

4b. Through your experiences, how do physical fabrication practitioners/departments/ companies communicate with digital practitioners/departments/ companies and what is the full process?

N/A

4c. What systems and technologies of design and making would make this process easier?

In terms of cost effectiveness, digital embroidery is where it is at but when it's close up it's difficult to get that hand look. When it's further back [it was fine].

4d. What systems and technologies of design and making would you like to learn?

A lot of the computing stuff, Illustrator would be really good, InDesign, those sorts of programmes are invaluable. Not particularly interested in the digital patternmaking because I'm quite a tactile person but then again, if that's what I have to do then maybe it's what I should probably be doing.

4e. What practitioners/ departments/companies would you like to collaborate with?

N/A

5a. Within the costume design and making process, do you feel digital technologies are relevant?

Yes because it saves time. Often you get a stunt garment and a hero garment, it has to look the same on film and sometimes [the stunt garment] will have openings for harnesses but the body shape might be different. So being able to do a digital pattern and then change it for the stunt would save a lot of time. If you have a scanned body you can check the design lines. We started using scanned bodies which were really good because all the proportions for the body size instead of measuring them. What was really important was the position that people were standing in because it change the lengths, depending how you stand or if their arm is at an odd angle then it was quite hard to get it straight. You don't want their arms [down] because then you can't dress it but then you don't want them unnaturally out. It's really cool having a dummy that is their size and shape and then think 'yeah, this looks right' especially once you've sewn [the costume] up and it gets sent to the leather room to glue on the armour pieces, they could put them in the right place. For this project the seams couldn't be shown so the armour pieces could be placed on and then work out where to hid the seams.

5b. Within the costume design and making process, do you believe it is important to be exploring digital technologies further?

N/A

5c. In your experience, what are current limitations in digital and physical technologies within the costume design and making process?

N/A

5d. Within the costume design and making process, where do you think the innovation of technology is going in the industry (From digital patternmaking, Made-to-Measure to Digital Simulation), where would you like to see it head? And what would you like to see the next generation of costume designers learning?

[Company B] is still using padded dummies so the scanned dummies were incredible, a whole different ballpark. [Company A] doesn't have a big fabric component... they specialise in armour so there isn't enough work [to offset the cost of patternmaking software]. I'm interested that [Company B] doesn't have it but they form production companies each time a film is done so it's not always the same crew. I know with the armour, the 3D guys are doing a lot more of the 3D printed stuff. When you get to more complicated shapes they still do it by hand...it's really helped them in terms of cost and time.

Absolutely [it is important for future generations to be looking at technology]

(Appendix E)

Interview with Interviewee C,

28th May, 2019

1a. When thinking about your job in the area of costume for film which space do you currently sit within?

It has mostly been physical but now it is both, it's becoming more and more both.

1b. Do you work in:

Production/Fabrication

But I want to work more within concept design. I am more and more, with becoming sort of assistant designer level. It ends up being that the designer has a concept and you have to think about how can we make that a workflow for the workroom. For example, this fabric which looks like nothing right now but what if we dyed it, printed it, cut it? So, it's that whole process of the workroom. They [concept designers] don't really know about seams or how fabric would fall and so you get these references that don't make sense and then your supervisor would say 'well I can see seams there' and that's just because the concept designer didn't know what they were doing and so we don't follow it exactly.

1c. What area did you train in?

Fashion Design

Industrial Design

Self-taught

Industry-taught

2a. What is your level of experience in the film industry (no. of years)

11

2b. Can you briefly describe what your job comprises of:

The last job I did at [Company A] was really cool because I was working by myself and was given a time budget. I got a total number of hours I could use and also had references from the designers. So it was a mix of making, and sourcing, and adapting bought garments but interestingly what I'm really doing now is making a reference for [Company C] to make a digital costume, so it has totally changed. My output is, I do make a costume, but I do the breakdown and everything. So then we film it, photograph it. The pattern and the finished garment and they're all references for digital recreations. That's really the output. That started for me on *Tin Tin* (2011) and now it's happening more and more. On the first *Avatar* (2009), my partner at the time was working in the creatures department and they cover cloth simulation, so they animate clothing. At that time when we were giving them references [costumes], like we understand a pattern is a 2D shape that becomes 3D, they were making 3D models of those clothes and they were complaining they weren't getting the right behaviour. It's made a jump since then and they are using patternmaking software called Marvelous Designer.

Comment: I'm working on a project at the moment and these colleagues of mine are doing a part film, part VR game so it's not a game or a film, it's somewhere in between. Their feedback, they just chose digital costumes and the costumes are really American sitcom and they don't like the costumes so they wanted some help with digital costumes. I'm doing some concepts for them and what they're hoping and I think this is totally possible, there are these digital costume marketplaces where you can find similar ones and they can change a little bit of them so that's been a new way of working for me to. They were sure there was nothing good on these marketplaces and I'm like there's heaps of good stuff, there's like

handmade jumpers. Because it's easy to change the colour and the texture and I guess because they've got the patternmaking thing, I'm saying 'well that's the base garment that you want' so it's quite cool.

2c. When thinking about your current employment do you work:

In a team within a company 100+

3a: In your workplace, do you get the opportunity to work between different departments or companies?

Yes

3b: If yes, what kinds of companies and/or departments do you go between? And why?

Imaging, I do a lot of work with them because they are so integral to the references and then collaborating between [Company C] and [Company A], we are working on the same project and they need us to give them information as well so it is a communication [between the two companies]. They are physically in different places and there is a completely different way of working and a different culture. I'm also one of the few people that jumps between two workshops/studios.

3c: If no, what kinds of companies and/or departments would you like to go between? And why?

N/A

4a: Can you describe the nature of collaboration between different practitioners, departments or companies in relation to authenticity for the design and making of physical and digital costumes?

It's finding a way to speak the same language because we have two different work flows but it's interesting. For the last project I was on, we went to a conference at [Company C] and they had tried making digital versions and they were having a lot of trouble under the arms and between the legs because it was bunching in a weird way. It's because they didn't know anything about patternmaking so they needed us and it was decided we needed actual costumes. They came back to us and we made the patterns and they started again and we gave them the information, so both are needed still. It is nice because I think when costume started being digital I think people were worried that the real costume industry was going to fizzle out but actually, you will always need it.

4b. Through your experiences, how do physical fabrication practitioners/departments/ companies communicate with digital practitioners/departments/ companies and what is the full process?

You go through production still, so you still need the production teams to be communicating quite formally. You need a design brief, and you need a lot of imaging and know what are the outputs you need. Then is just a lot of emailing back and forward and there is a lot of imaging. For example, on my last job, me being the fabricator or the manufacturer or the prototyper, I was really sitting between the concept artist and the digital so it was that workflow. Then you definitely need people liaising between and it is hard to speak the same language. The concept artists were in L.A and then I was in one part of Wellington and the digital were in another part of Wellington but we may as well have been in different countries because it's a lot of long distance communication still.

4c. What systems and technologies of design and making would make this process easier?

Definitely time management systems. Image sharing software is probably the hardest thing because you'll be uploading to Dropbox or equivalents like that and getting people to see. It is challenging to communicate like that because there is a lot of (example) 'on image 3 we like this but we don't like this' so if we had really good imaging with note taking, like being able to write hand written notes all over it.

4d. What systems and technologies of design and making would you like to learn?

Definitely the digital patternmaking.

4e. What practitioners/ departments/companies would you like to collaborate with?

I'm collaborating with both [education] and [film industry] and those are both dream collaborators, so I'm doing it.

5a. Within the costume design and making process, do you feel digital technologies are relevant?

Yeah, definitely getting more and more relevant. The more films are being made digitally, the more that has to happen.

5b. Within the costume design and making process, do you believe it is important to be exploring digital technologies further?

Yes. What you should be recognizing that the costume department at [Company C] is growing so they used to just be doing cloth simulation but now they are stitching together costumes. Whereas at [Company B], we are still using the same things but if we were doing it in house, the digital would be growing.

5c. In your experience, what are current limitations in digital and physical technologies within the costume design and making process?

I feel like there isn't, we can do anything, everything. We might outsource things like laser cutting or 3D printing.

5d. Within the costume design and making process, where do you think the innovation of technology is going in the industry (From digital patternmaking, Made-to-Measure to Digital Simulation), where would you like to see it head? And what would you like to see the next generation of costume designers learning?

I think it's going in a really interesting way and it'll be interesting to see where it goes, it's just getting more and more realistic and it's that shift from them thinking about a garment being 3D to being 2D to 3D is a really big leap forward.

I really want them (future costume designers) to keep learning 2D to 3D design in the real space and not just digitally made costumes. I really think that ability to conceptualise a 3D form broken down in to 2D shapes is really, really important. Fashion designers and costume designers really need to learn that spatial awareness still and you can do that through patternmaking.

Other comments: About *Alita: Battle Angel* (2019) (In response to me asking: did you make all of her costumes?) So they had already filmed it and then decided they didn't like the costumes so they were replacing all of her costumes... (Did you have to make any physical costumes for them?) I did all of them, so what they did was they pre-designed 18 looks and then I did a mix of shopping, and they did some shopping and then we adapted them. It wasn't for a normal body so we milled a 3D model out of polystyrene. That's where my background in practical skills like draping and adapting and altering (came in). So I made a reference for all of them, some were made and adapted and some were made from scratch. Then we would have pantone swatch for the colour and a swatch of the print. So it wasn't about the colour or texture, it was about the shape and drape and movement. Then it's handing over physical garments, the video goes to the animation department, the photos stills go to the modelling department and the pattern goes to creatures who digitize it and stitch it together. They used to look at your garment and make a 3D model but it's a human interpretation of it, sort of like a 3D scanner would but if you give them a pattern they can trust that they can stitch it together and it will behave the way you want because we are doing anthropometrics so we are doing a garment that's built in for the movement of the body and drape and fit. Plus we do different things to the fabrics depending on the fabric that it is so you can't really take the patternmaker out of that process. It will be interesting to see how the digital costumes that get bought behave, who have they been made by? They look right but do they move right?

(Appendix F)

Survey Results

Participant A: 20th November 2018

Participant B: 12th December 2018

1a. When thinking about your job in the area of costume for film which space do you currently sit within?

A: Both - I design and/or make for both

B: Physical - I design and/or make costumes for physical actors

1b. Do you work in:

A: Concept design, Production/Fabrication

B: Production/Fabrication

1c. What area did you train in?

A: Film, Industrial Design, Textile design, Self-Taught, Industry-Taught

B: Fashion Design, Self-Taught, Industry-Taught, Formally taught (University, Polytechnic etc)

2a. What is your level of experience in the film industry (no. of years)

A: 18

B: 2

2b. Can you briefly describe what your job comprises of (paragraph):

A: Production manage costume manufacture mainly for film.

B: Making costume for film including sewing, pattern drafting, cutting, gluing, sanding etc

2c. When thinking about your current employment do you work:

A: In a team within a company 10+

B: In a team within a company 100+

3a: In your workplace, do you get the opportunity to work between different departments or companies?

A: Yes

B: No

3b: If yes, what kinds of companies and/or departments do you go between? And why?

A: Art, costume, special effects, makeup, set dec, armoury...

B: N/A

3c: If no, what kinds of companies and/or departments would you like to go between? And why?

A: N/A

B: N/A

4a: Can you describe the nature of collaboration between different practitioners, departments or companies in relation to authenticity for the design and making of physical and digital costumes?

A: N/A

B: Pretty good between departments. designers don't think of practicality so then when the final pieces come to the costumer and we put it together often they don't function how they should. If they brought in a costumer at the beginning there would be less of this happening.

4b. Through your experiences, how do physical fabrication practitioners/departments/ companies communicate with digital practitioners/departments/ companies and what is the full process?

A: Through people like me. Or we hire project based digital techs

B: Pretty good I believe, I've only done a few projects. Usually we make the real thing and they replicate that digitally.

4c. What systems and technologies of design and making would make this process easier?

A: N/A

B: Not sure

4d. What systems and technologies of design and making would you like to learn?

A: N/A

B: Allsorts learn as much as I can really

4e. What practitioners/ departments/companies would you like to collaborate with?

A: N/A

B: Designers more I suppose but with all departments as that's how your best work is produced.

5a. Within the costume design and making process, do you feel digital technologies are relevant?

A: Yes

B: Yes

5b. Within the costume design and making process, do you believe it is important to be exploring digital technologies further?

A: Yes

B: Yes

5c. In your experience, what are current limitations in digital and physical technologies within the costume design and making process?

A: Unstable, impermanent industry in NZ and internationally. Little budget for R&D. No time in the actual film production to develop ideas, methods, processes.

B: Texture and understanding fabric and movement correctly

5d. Within the costume design and making process, where do you think the innovation of technology is going in the industry (From digital patternmaking, Made-to-Measure to Digital Simulation), where would you like to see it head? And what would you like to see the next generation of costume designers learning?

A: A costume designer is a coordinator of people and resources translating the vision of the director/ producer within a given time/ budget. The future is in the skills and resources in the wider landscape.

B: That's a hard one realistically I feel that there is too much digital now and that you need real costumes and real props etc. I think there needs to be a balance. Designers need to learn how to make. Especially digital designers. They don't understand functionality