

Copyright is owned by the Author of the thesis. Permission is given for a copy to be downloaded by an individual for the purpose of research and private study only. The thesis may not be reproduced elsewhere without the permission of the Author.



Rethinking clamshell packaging

***An exploration of packaging design
for the kiwiberry industry.***

An exegesis presented in partial fulfillment of the requirements for the degree of Masters of Design.
Massey University, College of Creative Arts,
Wellington, New Zealand.

Justin Hughes, 2018





Acknowledgements

To my supervisors, Matthijs Siljee, Andrew East and Eli Gray-Stuart thank you for their guidance, support and for giving me the opportunity to do this master's project. Thank you to our industry partners Carol Ward and Kylie Phillips from Zespri and Tracy Burns and Rodger Bayly from Freshmax Ltm whose involvement made this project possible. An extra thanks need to go to Zespri for providing funding for conducting field research in Asia.

Other acknowledgements need to go to my friends and family for all their care and support as well as my fellow master's students for their comradery. Finally special thanks to Jia Fang who assisted me with my research in Singapore and Taiwan and Lauren Deacon, Nick Dephoff and Nigel Hughes for your editing assistance.



Abstract

This project explores how designers can contribute to New Zealand's food industries by devising creative packaging solutions which enhance the consumer experience and add value to the products . It focuses on the values that packaging design can bring to the kiwiberry industry and the Asian market.

The kiwiberry, of which New Zealand is a major supplier, is a delicate, seasonal fruit with a high cost of production. Multidisciplinary connections between the Massey Institute of Food Science and Technology, Massey University School of Design, and kiwifruit industry partners Zespri and Freshmax were key to gaining insight into the packaging design opportunities for the kiwiberry. The investigation included research trips to Singapore, Taiwan and Hong Kong which were critical to gaining personal insight into the culture, consumer trends, supply chains and retail environments in these markets. These trips highlight the importance of fruit presentation in the Asian market as well as reassurances of food safety and authenticity. They also show that new technologies throughout the fruit supply chain are creating opportunities to develop smarter and more engaging packaging formats. Using these industry and market insights, I seek to generate and create designs which acknowledge current packaging technologies, but also speculate as to where the future of fresh fruit packaging could go. The outcome I conceive is a packaging design concept that addresses the technical needs of the fruit industry while putting a greater emphasis on the consumer experience.

List of figures

Unless mentioned otherwise, all figures by author.

- 12 Figure 1: The Double Diamond Process (Design Council, 2015)
- 20 Figure 2: R-Pet clamshell punnet currently used to package
kiwiberries
- 20 Figure 3: Example of sealed film blueberry packaging
(field research Hong Kong)
- 21 Figure 4: Visual exploration of form and meaning within packaging
- 24 Figure 5: Model of consumer responses to product form
(Bloch, 1995)
- 23 Figure 6: Street stall selling fresh cut fruits (field research Taipei)
- 25 Figure 7A: Melon gift set (field reserch Hong Kong)
- 26 Figure 7B: Apple gift basket (following page - field reserch Taipei)
- 27 Figure 8: Screen shot of Ali Baba's demonstration video of a
'Hema' Supermarkett experience
- 28 Figure 9: Example of fruit for sale on Fruitday.com
- 29 Figure 10: Rockit apple packaging and Rockit apples in wholesale
market in Taipei
- 30 Figure 11: Kiwi Delight cherry packaging
- 35 Figure 12: Machines sort kiwiberries in two size categories with the
larger being export grade
- 35 Figure 13: Quality control, defective fruits are manually removed
- 35 Figure 14: Clamshells being mechanically placed on loading con-
veyor
- 36 Figure 15: Kiwiberries being loaded into clamshells and manually
shaken to settle the berries
- 36 Figure 16: Stickers being placed on clamshell punnets
- 36 Figure 17: Clamshell punnets stacked in packing trays
- 37 Figure 18: Boutique fruit store in central Taipei
- 39 Figure 19: Example of store owners adding additional packaging to
protect kiwiberries
- 40-41 Figure 20: Examples of fruit packaging and displays from super-
markets in Taipei and Singapore
- 43 Figure 21: Consumer surveys
- 44 Figure 22: Me with Zespri mascots at Asia Fruit Logistica Asia 2017
- 45 Figure 23: Examples of product displays and marketing from Asia
Fruit Logistica Asia 2017
- 46 Figure 24: Mind maps of the supply chain and key considerations.
- 47 Figure 25: Consumer interaction journey map
- 49 Figure 26: Silicone casts of kiwiberries and moulds
- 50 Figure 27: Material explorations with moulded fibre, PLA foam and
thermo-formed plactics
- 50 Figure 28: Material explorations with moulded fibre, cardboard,
PLA foam, polystyrene and thermo-formed plactics
- 52 Figure 29: Explorations into colour of packaging and fruit
arrangement

- 52 Figure 30: Explorations into colour interplay with kiwiberries
- 55 Figure 31: Initial ideation sketches and models
- 56 Figure 32: The Jaws concept
- 56 Figure 33: The End Caps concept
- 57 Figure 34: The Slider concept
- 57 Figure 35: The Rows / Egg Carton concept
- 58 Figure 36: Sketch models of different iterations on the four main concepts shown on the previous page
- 61 Figure 37: Concept 1 film with ribs with different rib patterns
- 61 Figure 38: Folds in the film create extra rigidity along the bottom of the packet
- 63 Figure 39: Prototype 2: Sealed shell
- 64 Figure 40: Prototype of augmented reality *kawaii* character icon
- 66 Figure 41: Prototype of multi-pack carry case
- 67 Figure 42: Prototype of multi-pack carry case technical iteration
- 67 Figure 43: Exploration of multi-pack colourways and graphics
- 71 Figure 44: Kiwi-pack packaging system
- 72 Figure 45: Kiwi-pack packaging system components
- 73 Figure 46: Anti-coupling details
- 73 Figure 47: Diagram of airflow around the kiwiberries
- 74 Figure 48: Re-sealable lid and tabs hooking lid in place
- 74 Figure 49: The unique QR code linked to product website
- 75 Figure 50: Twin pack being snapped into two halves
- 76 Figure 51: Secondary packaging
- 77 Figure 52: CAD models of form explorations and dimensional refinements
- 77 Figure 53: Experimentation with form detailing
- 78 Figure 54: Packing configuration of primary packaging in tertiary packing tray
- 78 Figure 55: Fruit capacity of current clamshell holding two fewer kiwiberries than the Kiwi-pack design
- 78 Figure 56: Space efficiency of Kiwi-pack design compared with current clamshell package
- 79 Figure 57: Iterations of tabs and opening function of sealed film
- 80 Figure 58: Creation of moulds and thermo-forming process
- 80 Figure 59: Finalised mould (following page)

Table of contents

III	Acknowledgements
V	Abstract
VI	List of figures
VIII	Table of contents
2	Chapter 1: Introduction
3	Context: Introducing the kiwiberry industry
3	The broader Ari-food industry context
4	The market context
4	Research aims
8	Chapter 2: Methods and Processes
9	Exploration of the kiwiberry industry in NZ
9	Observation
9	Visual documentation
9	Semi-structured interviews
10	Exploration of markets in Asia: Singapore, Taipei and Hong Kong
10	Visual Ethnography
10	Semi-structured interviews
11	Semi-structured survey
12	Design methodologies
13	Limitations
16	Chapter 3: Contextual review
16	Overview of the kiwiberry industry
18	Challenges of designing fresh berry packaging
21	Disconnection between production and communication of packaging design
22	Food, packaging and the consumer experience

24	Characteristics of the Asian market
29	Case studies
29	Rokit apples
30	Kiwi Delight cherries
31	Summary of key findings
34	Chapter 4: Design process
34	Discovery phase
34	Engagement with the Institute of Food Science and Technology
34	The pack houses and packing process
37	Reflection on field research in Asia
47	Defining phase
47	Journey mapping
48	Design criteria
49	Development phase
49	Initial design experiments/explorations
54	Ideation stage
60	Prototype 1: Film with ribs
62	Prototype 2: Sealed film shell
64	Exploration into packaging as a system
70	Chapter 5: Final design
77	Design refinement process
84	Chapter 6: Conclusion
86	Reference list
90	Appendix 1: Ethics approval
91	Appendix 2: Participant consent forms
102	Appendix 3: Consumer surveys



Chapter 1

Introduction

Toward the end of 2016 I was offered the opportunity to do a master's degree project that looked at adding value to New Zealand fruit exports through packaging design. I took on this project as an interesting opportunity to collaborate with the horticulture industry and explore the relationships between design and food. This project was in conjunction with the Massey Institute of Food Science and Technology in Palmerston North, and developed a partnership with stakeholders in the kiwiberry industry, Zespri and Freshmax. Initial discussions with these stakeholders revealed their keen interest in finding an improved packaging format that better suited the unique characteristics of the kiwiberry. After further consultation with my supervisors the primary aims of this project were established with the central research aim as follows:

To explore creative packaging solutions that are in keeping with the characteristics of kiwiberries, that add value to the product and that embody some of the values held by target markets in Asia.

Designing packaging for kiwiberries is at the core of this project, but this project also acts as a vehicle to explore the intersection between the disciplines of design and food science technology. This research asserts the relevance of design practice within food production industries by offering a critical view of the way food products are presented to and experienced by consumers.

Design brings different sets of strategies and skills that when coupled with the skills and methods used in food science technology can open up new and interesting pathways to add value and enhance the consumer's experience of food products.

Context: Introducing the kiwiberry industry

The kiwifruit industry in New Zealand is one of the country's largest food exporters, and kiwifruit is the single largest horticultural export by volume and value. In 2016 the industry generated over one billion dollars in trade (New Zealand Horticultural Export Authority, 2016). In recent years, a new segment of the industry has been developed around the kiwiberry which is outlined in greater detail in chapter 3. The kiwiberry is part of the wider kiwifruit family but with some distinct differences. A kiwiberry is small (about the size of a large table grape) with smooth, edible skin and has a sweet flavour like the gold kiwifruit. Like many other berry fruits, kiwiberries represent a high-value export crop for the horticulture sector.

Kiwiberries are currently packaged in clear plastic clamshell punnets. However, there is a potential disconnect between the high value of the fruit and the perceived low value of its packaging. The kiwiberry industry is relatively young, and this creates the challenge of developing and optimising its supply chains around the characteristics of the fruit. This is coupled with the twin challenges of increasing consumer awareness of and demand for this fruit (Bez, 2016). Asia represents the target markets for New Zealand's kiwiberry exports, but it is still a relatively new product in a large and complex marketplace. In an increasingly saturated market environment the way a food product is displayed and packaged becomes vital in differentiating the product and enticing consumers (Hendrik N. J. Schifferstein, Fenko, Desmet, Labbe, & Martin, 2013). This gives added importance to having the right packaging for kiwiberries to enhance their market appeal and increase consumer awareness.

The broader agri-food industry context

This project operates within the context of a growing trend in the agri-food sector. This trend is a push to take a more value-added approach to produce more premium food products to generate higher export revenue. Saunders et al. (2011) argues, "as land available for increased production of agricultural commodities is limited in New Zealand, future growth needs to come from increased value of production rather than increased volumes." (p. 6).

According to Saunders et al (2011), the agri-foods sector is not doing enough to bring the food products that are being produced up the value chain, and this is resulting in missed potential export revenue. A recent report released by the financial firm KPMG stated that in 2015 agri-food exports from New Zealand totalled \$37 billion, while \$250 billion was the estimated total value of sales of New Zealand agri-food products on-sold to final consumer (Proudfoot, 2016).

New Zealand's horticulture industry aims to increase production from \$6

billion (in 2011) to \$10 billion by 2020. To achieve this, a greater focus will be put into maintaining and building the premium status of New Zealand produce in the global market (Plant and Food Research, 2017).

Beverland (2001) states that for New Zealand fruit producers to set their product apart in an international market, strong brands will become an increasingly important tool. Good packaging as part of developing a strong food brand can define a product's identity and add experiential value that lasts in the minds of consumers to create positive associations with that food product (Yuri Seo, Angela Gracia B. Cruz, & Kim-Shyan Fam, 2015) (Spence, 2017) (Hendrik N. J. Schifferstein et al., 2013).

The market context

Asia represents a large and lucrative market for New Zealand's kiwiberry industry, and, as I will explore further in chapters two and three, it comes with its unique challenges and opportunities. The kiwiberry industry recognises the importance of understanding the characteristics of the consumers and the markets they export to. As with any industry that exports into different cultural contexts, there is the need to find relevant ways to present products in a way which resonates with the values of the target audience. This is something that the wider agriculture sector has had to grapple with over the last two decades. Traditionally New Zealand's agri-food exports have relied on key markets such as the UK, though more recently there has been a greater focus on Asian markets like Japan, China and Taiwan (Driver, Saunders, Guenther, Dalziel, & Rutherford, 2015). With this shift, the industry has had to ask itself an important question: how to do we tailor our products to appeal to Asian consumers?

The fourth chapter of this thesis outlines the wider social and cultural influences in Asia that influence consumer relationships with fruits in general, and more specifically with packaged fruits such as berries. It also examines current and emerging packaging and retail trends within these markets and the relevance these factors have in relation to the design of packaging for the kiwiberry.

Research aims

Full disclosure: Industry sponsored project

This is a sponsored project and has been co-funded by Zespri and Massey University's Centre of Postharvest Research. Additional stakeholders are Freshmax Ltd . who have provided support in the form of market access as well as access to orchards and packing facilities.

Main objective

This industry-focused project centres on producing creative packaging solutions for the kiwiberry that, compared to the current packaging, better reflect the value of the product and resonate more with primary consumers in export markets in Asia, such as Taiwan, Hong Kong and Singapore.

This project has three main objectives:

- To act as a catalyst for collaboration between the agri-food sector (in this instance, the companies Zespri and Freshmax), Massey Institute of Food Science and Technology and the Massey University College of Creative Arts. Through this collaboration, I seek to generate knowledge of how the separate paradigms of technology, marketing and design can be successfully brought together within the context of the NZ food industry.
- To develop an understanding of the role of design for the consumer experience in relation to food products and the potential opportunities this can open up.
- To explore cross-cultural design for global markets. If a designer familiar principally with the lived experience of New Zealand creates a consumer experience for a consumer familiar principally with the lived experience of an Asian nation, how do we learn about that consumer?

Design intentions

- To take an explorative approach to packaging design to generate speculative ideas as to how kiwiberries could be packaged in the next five to ten years.
- To look at current and emerging technologies and explore how these could be incorporated into new packaging formats.
- To address current market demands as well the desires and expectations of consumers in Asia.
- To address the future of the food retail environment and the consumer experience.



Chapter 2

Methods and Processes

The research methodologies and processes employed for this project were driven by a need to gain a broad understanding of the kiwiberry industry and the markets and consumers it supplies.

As a designer, I was looking to corroborate the information that the industry already had with experiential/phenomenological data. A qualitative research approach was employed to gain a more holistic understanding of the complex issues this project addresses. This method of research allows for flexibility when exploring a range of contexts and settings (Creswell, 2018).

For my practice, seeing and experiencing what I am designing for is vital to gaining meaningful insights. A qualitative approach provided the main methods of research, but this was supported by engaging the expertise of individuals working in specialised areas of packaging and post-harvest technologies.

The discovery phase of this research can be split in two sections:

- Exploration of the kiwiberry industry and broader packaging industry and horticulture sectors, undertaken locally.
- Field research in Asia which encompassed the importers and wholesalers, the retail environment, the consumers and the broader cultural and societal backdrop.

Note: This research was conducted with low risk ethics approval (see appendix 1 p.90).

Exploration of the kiwiberry industry in NZ

First hand exploration was necessary to define the needs of the industry. This meant visiting and engaging with companies, research institutes and individuals whose work was relevant and contributed to the kiwiberry industry and wider horticulture sector.

Observation

First-hand observation was an important component of gaining deeper understanding of the different processes that go into the manufacture of packaging, packing and exporting of kiwiberries. This first-hand observation also allowed me to create a visual record of the environments and processes I had seen.

Visual records

Photographic video records were taken during field research as part of a qualitative research practice. Creating visual records allows the researcher to record truthfully some of the details and moments that could otherwise get lost through other forms of data collection (Pink, 2013). Video and photographic surveys can also provide a way to bring together physical objects and environments with the narratives of the individual's work and interact with them (Creswell, 2018) (Pink, 2013).

Semi-structured interviews

The other important component of this phase of research was semi-structured interviews. By asking open-ended questions, the interviewer creates opportunities for the participant to provide their perspectives on key issues and topics while also introducing new topics that may not have been considered by the interviewer. It also creates an opportunity for the interviewee to be more frank (Gray, 2009).

Exploration of markets in Asia: Singapore, Taipei and Hong Kong

***“There is no substitute for direct observation of and interaction with the people who will be using the product.”
(Norman, 2013, p. 223-224)***

As part of the primary research for this project, two trips to Asia were undertaken to gather first-hand insights into the market characteristics. The first trip was a ten-day exploration of the Singapore and Taipei markets which is where the bulk of the primary research was conducted. The dates of this trip, from late April to early May 2017, were timed to coincide with the availability of kiwiberries in the local market. The second trip was a four-day exploration of Hong Kong in September and encompassed a fresh fruit industry trade conference. Both trips comprised visits to importers, wholesalers and retail environments where kiwiberries were available for sale. Three main methods of research were used during these trips as shown below.

Visual ethnography

This methodology is used in qualitative research for understanding and describing experiences, culture and society, as well as the material and sensorial environments (Pink, 2013). This research took the form of personal observations and photographic documentation. These methods focused on wholesale and retail environments where kiwiberries were sold, as well as on the broader representations and packaging of fruit.

Semi-structured interviews

Semi-structured interviews were conducted with industry professionals in all three of the locations visited in Asia. The participants interviewed offered valuable insights into broader characteristics of the markets visited, as well as more acute insights into consumer perceptions relating to fresh fruit packaging and the kiwiberries.

List of Locations and participants interviewed

Singapore

- Shermaine Tan — Business Development Manager, Tian Sheng Fresh Produce (kiwiberry importer).
- Kelvin Goh — Associate Professor/Programme Director, SIT- Massey Food Technology, Singapore.
- Kaiyang Lim — Researcher, SIT- Massey Food Technology, Singapore.
- Lee Yenyen — Researcher, SIT- Massey Food Technology, Singapore.

Taipei

- Joanne Chen — Marketing Manager, Zespri, Taiwan.
- Emi Chen — Marketing Manager, Zespri, Taiwan.

Hong Kong

- Helen Tang — Marketing Manager, Zespri, China.
- Rita Chen — Regional Marketing Manager, Zespri, Taiwan, Hong Kong and Korea.

Semi-structured survey

The semi-structured survey was conducted with members of the public in both Singapore and Taiwan. Participants were asked a series of open-ended questions relating to consumption habits and perceptions of berry fruit, berry fruit packaging and kiwiberries. This was a qualitative research exercise and was intended to gather candid insights rather than statistical data. These surveys can be seen in appendix 3, p.102.

Design Methodologies

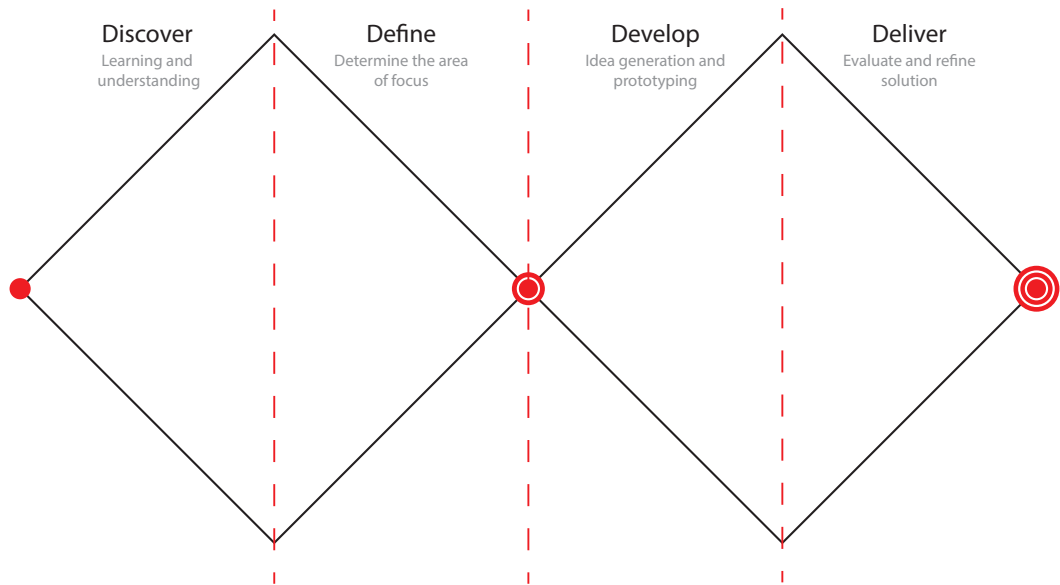

Figure 1: The Double Diamond Process (Design Council, 2015)

The double diamond method

“In all creative processes, a number of possible ideas are created (divergent thinking), before refining and narrowing down to the best idea (convergent thinking).” (Design Council, 2015, p.1)

The double diamond design method provided a framework from which to approach this design project. I needed to be flexible within this framework to allow for new information gathered from field research at different stages of this project. This also allowed me to incorporate into this design framework the principles of human centred design and activity based design (Norman, 2013).

Sketch modelling and Prototyping

Sketch modelling is a quick and efficient way to explore a design idea and see how it might function in the real world (Aspelund, 2014). Physical modelling and prototyping was used extensively in successive waves of conceptualisation, iteration and refinement. This methodology was also used during the early stages of the design process to test and respond to findings from contextual and primary research.

Limitations

The overall aims of this project were achieved, but it is important to acknowledge that there were some limitations to the research methods used. These include:

- Limited access to fruit due to the short, two month, season of availability.
- Designing externally from the primary markets. Although a great deal of insight was gained during my visits to Singapore, Taipei and Hong Kong, as a Pakeha New Zealander my understanding of these markets is still limited compared with someone living and working in these environments.
- The limited number of survey participants. Although the survey was of a qualitative nature, a larger pool of participants would have yielded information more representative of a broader consumer base.



Chapter 3

Contextual review:

Overview of the kiwiberry industry

Whilst the kiwifruit industry in New Zealand is well established, the commercial cultivation of kiwiberries is relatively new, having been around for close to seven years. New Zealand is one of the leading suppliers of kiwiberries to the global market; however, the product has a low yield volume compared to other fruits. According to New Zealand Kiwiberry Growers Inc., there are approximately 200 hectares of commercial kiwiberry production internationally, with 22 hectares in NZ.

As the kiwiberry industry evolves, a greater focus is put into improving and optimising the growing and supply chain as well as developing consumer awareness. Importantly, packaging is a vital part of making the kiwiberry a viable commercial fruit. Below are some key attributes of the kiwiberry:

- It sits within the wider Actinidia fruit group which includes the more commonly known green and gold kiwifruit.
- Although it tastes similar to kiwifruit, it is noticeably smaller (20–30mm diameter / 5–20 grams) and has a smooth edible skin, allowing it to be eaten whole. Refer to following page to see kiwiberry in current clamshell packaging.
- Because kiwiberries are a seasonal crop (the New Zealand season runs from late February to early April), there is a great incentive to get the fruit to market promptly. Picked at its prime and stored at 0 degrees, the shelf-life of the kiwiberry can be extended to 10 to 12 weeks (Bez, 2017). This is a low storage life compared to kiwifruit, which can be stored for up to six months (H. N. J. Schifferstein, 2016) (Bez, 2016).



MUNCH'N
KAWBERRIES

NET - 520 FLAVORED KE
Produced in Massachusetts
All Natural Fruit, No Added Sugar
www.freshfruit.com

MUNCH'N
KAWBERRIES

NET - 520 FLAVORED KE
Produced in Massachusetts
All Natural Fruit, No Added Sugar
www.freshfruit.com

MUNCH'N
KAWBERRIES

MUNCH'N
KAWBERRIES

MUNCH'N
KAWBERRIES

Challenges of designing fresh berry packaging

One key challenge when designing packaging for fresh fruit is perishability (Brunazzi, Parisi, & Pereno, 2014). Due to their delicacy and short shelf-lives, kiwiberries are very susceptible to damage from multiple sources, including physical (crushing and rubbing), environmental (temperature and humidity), and biological (fungal and bacterial). This limits effective transport options to airfreight only. Optimal and controlled storage conditions seek to maintain quality and minimise any factors that may cause damage or accelerate the natural processes that cause decomposition (Bez, 2016; Fisk, Silver, Strik, & Zhao, 2008).

Fresh fruit packaging is manufactured with the implicit understanding that it is a vital component of the cool-chain which facilitates getting fruit from pack-houses to consumers in pristine condition. To meet consumer expectations, producers' profitability margins, and regulatory bodies requirements, the different stages of manufacturing need to be safe, efficient, and economical (Robertson, 2013).

Due to the perishable nature of the fruit, the evolution of packaging has been driven by research into post-harvest technology in conjunction with the packaging manufacturing sector (Brody, Zhuang, & Han, 2011). To overcome the challenges that packaging berry fruits face, these disciplines put the characteristics of the fruit (respiration, moisture and dry-matter content) at the centre of the design, with economics and efficiencies also key considerations. Aside from reassuring consumers of the fruit's basic protection and food safety, the relevance of some of the technical details are not immediately obvious to most consumers and hold little experiential value (Robertson, 2013) (Brunazzi et al., 2014).

The influence of food supply chain on packaging design

Food supply chains have become a global network, and multi-national supermarket retailers play a defining role in shaping the types of food consumed and their packaging (Bassi, 2015). The complex scale of the global food economy has seen increased demand for food safety, and efficiency and reliability in supply chains. As such, there is a desire by multi-nationals to provide high-quality food products to their customers at consistently competitive prices. These companies have also played a role in influencing food safety regulations (Havinga, 2006).

Upon visiting a Waikato blueberry packing plant, I saw first-hand one of the critical elements of the supply chain, the post-harvest packing of fruit. This was a finely tuned, mechanised process where the packing conveyor speed is directly tied to profit margins.

Over the past few decades the fruit packing industry in developed economies has become increasingly mechanised and automated, and there has been a symbiotic relationship between the packaging formats and the configuration design of these machines (Burch & Lawrence, 2005).

Current packaging materials and manufacturing

Clamshell packaging is manufactured using thermo-forming, a relatively simple, efficient and economic process with each punnet clamshell costing around 12 to 13 cents. This involves a sheet of thermo-plastic, typically PET (polyethylene terephthalate) (Brunazzi et al., 2014), being heated to its softening temperature, then forced around the contours of a mould, either mechanically or using air-pressure, or a combination of the two. Once cool, the plastic form is removed from the mold and excess material trimmed off.

PET's suitability for the packaging of fresh produce comprises a number of material qualities including: holding its form and mechanical properties in high and low temperatures; being non-reactive to acids found in different fruits; and having a high degree of visual clarity, important for viewing product (Brunazzi et al., 2014).

Along with protecting and preserving fruit, PET is the most commonly recycled plastic (Jedlicka, 2009) and can be reused in the production of thermo-formed trays. This is referred as R-PET (Recycled PET), currently used in the packaging for kiwiberries.

Although the clamshell is still the most currently used packaging format for berry fruit, recently ¹modified atmosphere and sealed film packaging (See fig) has gained popularity in the berry industry (Fresh Plaza.com, 2017). Both of these types of packaging are more space efficient and use less material than clamshell packs, and the film provides a larger surface on which to print engaging graphics (Carless, 2016).

1 "Modified atmosphere packaging is a packaging technology that modifies or alters the gas composition around the products ... to provide an atmosphere for increased shelf life and to maintain the quality of the food." (Brody, Zhuang, & Han, 2011, p. 3)



Figure 1: R-Pet clamshell punnet currently used to package kiwiberries



Figure 2: Example of sealed film blueberry packaging (field research Hong Kong)

Disconnection between production and communication of packaging design

In his book, *Food Packaging: Principles and Practice*, Robertson states the “functions of packaging have been identified [as]: containment, protection, convenience and communication. These four functions are interconnected, and all must be assessed and considered simultaneously in the package development.” (p. 3)

Robertson goes on to say that the physical performance of the packaging is the primary role of the packaging engineer, while the communication functions are the concern of marketing experts. In contradiction to his earlier statement, this implies limited collaboration across disciplines (Robertson, 2013). The resulting process can create a disconnect between the development of the functional and communicative elements of the packaging whereby the functional elements are developed initially in isolation and the communicative functions added after (H. N. J. Schifferstein, 2016).

Schifferstein espouses the potential for design within the food industry to go beyond aesthetic value, instead looking at food products as a total experience. Design practice can widen the scope on an issue: “Designers tend to zoom out in order to see the bigger picture.” (p. 110) In the case of how people interact with food packaging as objects, this includes, “how they open the package, the actions they perform on the product, [and] how they put the food to their mouth.” (p. 110)

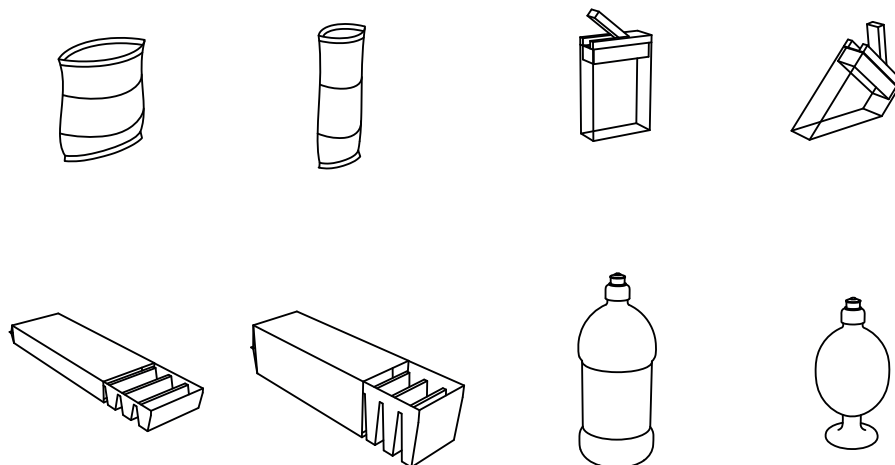

Figure 3: Visual exploration of form and meaning within packaging

Food, packaging and the consumer experience

Packaging performs a crucial role in informing the consumer about food products, and, in many cases, it can help to inform the eating experience itself. According to Qing, Lobo, and Chongguang, “Consumers attitudes towards [the] purchase of fruit is governed to a great extent by the importance they place on sensory and non-sensory attributes. ... Sensory attributes generally relate to consumers perceptions of the appearance, texture and flavour of fruit while non-sensory attributes relate to the location, brand, time and handling.” (p. 44)

Packaging can often serve, informally or intentionally, as a mode of serving the food it contains. It may also reflect the environment in which the product is sold or consumed, be it a high-end store, street vendor or domestic setting. As outlined in the above quote, this can influence an individual’s perception and expectation of a food product.

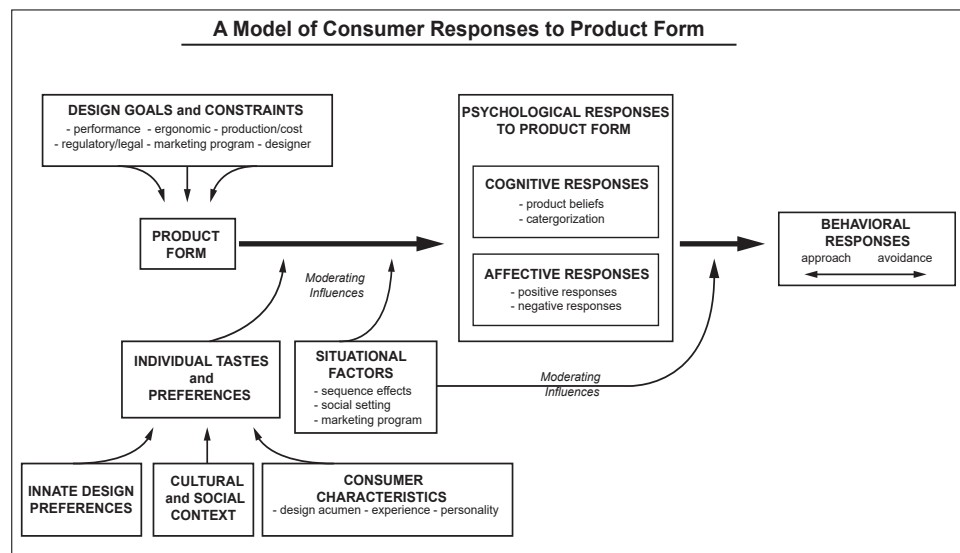

Figure 4: Model of consumer responses to product form (Bloch, 1995)

A product’s form influences initial perception and generates inferences around other aspects of the product (such as contents) (Bloch, 1995). (see figure 4). The understanding of form language is a mixture of learnt, cultural and social experiences (i.e. opening a jam jar screw-top lid) (Norman, 13). Without this meaning the usage or opening of the packaging would not necessarily be obvious to consumers. Using these conventions enables designers to use design details to signify how it should be opened.



Figure 5: Street stall selling fresh cut fruits (field research Taipei)

The importance of display: Colour and composition

The predominance of sight within the visually complex supermarket environment means it is imperative that fresh foods are attractively presented to the consumer. To ensure that products stand out and communicate effectively it is important to understand the different visual interactions that happen between consumers and fresh food products within this space. Initial interactions can set up expectations that form the foundation of how a consumer experiences a particular food (Hendrik N. J. Schifferstein, Fenko, Desmet, Labbe, & Martin, 2013). The process of visually engaging with a product often depends on physical proximity: at a distance detail is lost and text information may be unclear, so other visual signifiers such as shape and colour play a more important role.

Natural colours are vital in consumer perception of fresh fruit quality and attractiveness. Typically, red, orange and yellow hues are associated with sweeter flavours, while greenish hued fruit are commonly regarded as being unripe or having more sour flavour notes (Spence, 2017).

These colour associations are not a blanket rule but may influence consumer impressions, especially when encountering a new fruit.

Such associations were encountered during the informal interviews conducted as part of my research trip to Singapore and Taiwan. Participants were asked what, if any, experience they had had with kiwiberries. A recurring theme emerged among those who had never eaten one with many mentioning the green colour gave them the impression it would be sour. One participant even mentioned they looked like green olives (See Appendix 3-G2, p. 115).

This is important because discussions with importers and marketers in Taiwan and Singapore indicate that there is a clear demand for sweeter fruit in the Asian market (Personal communication Shermain Tan & Emi Chen, April 2017). Although kiwiberries are naturally sweet, their green colour may be misleading to those unfamiliar with the fruit.

Characteristics of the Asian market

Fundamental to the design process is to know who the end consumer is and what the characteristics of the selling market are. New Zealand kiwiberries are exported to Asian target markets in Singapore, Hong Kong, Taipei (Taiwan), Japan and, increasingly, China (Bez, 2016).

This part of the research focuses around three key areas:

- Consumer perceptions and values associated with imported fruits.
- Cultural, social and economic characteristics that influence how and why fresh fruit is consumed.
- Characteristics of the food retail environment in Asia and its effect on consumer experience of fresh fruit products.



Figure 7A: Melon gift set (field research Hong Kong)

Figure 7B: Apple gift basket (following page - field research Taipei)

Symbolic importance of fruit in Asian culture

Along with known dietary benefits, fruit holds symbolic meaning and hedonistic value that is unique to the Asian market place. A pronounced example of this is the custom of giving high-quality fruit as gifts, something commonplace across Japan, China and Taiwan.

“Visitors to Japan are often surprised by the displays in supermarkets - and the prices. Misshapen produce is kept off the shelves, and blemishes are banished. Grapes come in small, heavily-packaged bunches, each fruit the size of a plum and so sweet and flavoursome that Westerners may think they taste fake.” (Buerk, 2012)

Quality fruits as luxury items, and the purchasing habits around them, depend on what their intended use is. This could be for personal consumption, as a gift, or a healthy snack for children. Due to high prices and perception of quality, imported fruits are used extensively for gifts. “Good appearance and superior packaging means prestige and success”. (Sun & Collins, 2006, p.85).

1299

999
青森果物組合
JPN COMBO GIFT BOX
628511
青森地 日本青森縣

Japan
日本
999
青森果物組合
JPN COMBO GIFT BOX
628511
青森地 日本青森縣



1899
青森果物組合
JPN COMBO GIFT BOX
628511
青森地 日本青森縣

1699
青森果物組合
JPN COMBO GIFT BOX
628511
青森地 日本青森縣

2199
青森果物組合
JPN COMBO GIFT BOX
628511
青森地 日本青森縣

The changing nature of fresh food retail in Asia.

In Asia the supermarkets and the way fresh food is retailed are beginning to change with increased online retail services and greater integration between online and real-world retail experiences. Large online retailers like JD.com, Amazon and Fruitday.com are offering consumers premium fruit purchased in a convenient competitive online format. One example is Amazonfresh.com, which launched in Japan earlier this year, offering initial customers in Tokyo the option to choose from 17,000 fresh produce items with same day delivery.

As well as purchasing fruits online, there is an increased use of mobile devices to enhance and augment the physical supermarket shopping experience: “More than 70 per cent of respondents in each of China, India and Indonesia stated that they have used a mobile app for obtaining more information on food and beverages”. (Driver, Saunders, Guenther, Dalziel, & Rutherford, 2015, p.10).

Online retailer Alibaba has taken advantage of this trend by launch its pilot supermarkes‘Hema’ that integrates online and offline retail experience. The customer downloads the store's app and creates an account. Tracking software keeps a list of items the customer has chosen, and at the end of their shop the items are charged to their account without the need or a physical point of sale. Customers can also use the app to scan product codes for information about the product, such as nutritional value or place of origin. Although these types of retail innovations are not yet widespread, it is fair to say that they will have an increasing influence the years to come.

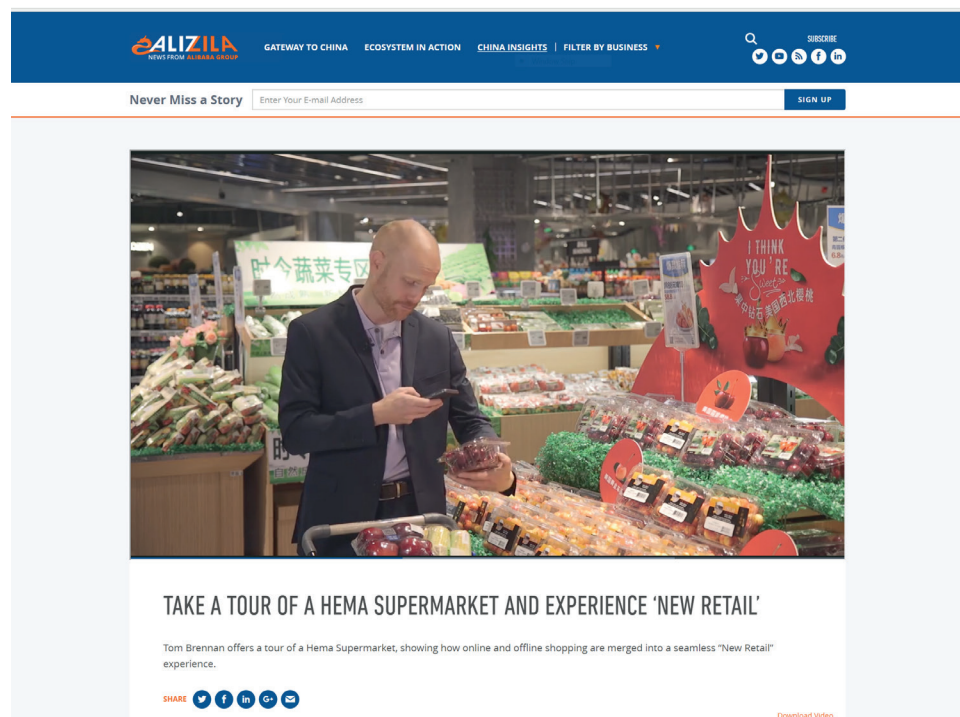

ALIZILA
NEWS FROM ALIBABA GROUP

GATEWAY TO CHINA | ECOSYSTEM IN ACTION | CHINA INSIGHTS | FILTER BY BUSINESS

Never Miss a Story [SIGN UP](#)

TAKE A TOUR OF A HEMA SUPERMARKET AND EXPERIENCE 'NEW RETAIL'

Tom Brennan offers a tour of a Hema Supermarket, showing how online and offline shopping are merged into a seamless "New Retail" experience.

SHARE [v](#) [f](#) [in](#) [+](#) [m](#)

[Download Video](#)

Figure 8: Screen shot of Ali Baba's demonstration video of a 'Hema' Supermarket experience

只有一份
极致的新鲜

[首页 Home](#)
[鲜果 Fruit](#)
[生鲜 Fresh](#)
[礼品 Gift](#)
[会员中心 VIP Club](#)

购物车

首页 购物车 订单

我的天呐! 这口感 妙不可言!

—吃难忘の人间美味大合集

智利甜心樱桃
一级甜樱桃 果径26-28mm

39.9元/500g

智利蓝莓
箱中闪耀的星星

69.9元/4盒

新奇士美国脐橙
阳光甜橙 饱再多汁

39.9元/6个

越南红心火龙果
每天都要很健康

98元/2.5kg

礼品卡券 更多 >

心怡水果礼盒
¥118.00/礼盒

心怡水果礼盒
¥188.00/礼盒

心怡水果干礼盒
¥188.00/礼盒

心怡水果礼盒
¥238.00/礼盒

心怡生鲜礼盒
¥238.00/礼盒

心怡水果礼盒
¥328.00/礼盒

心怡生鲜礼盒
¥328.00/礼盒

心怡水果礼盒
¥558.00/礼盒

心怡生鲜礼盒
¥558.00/礼盒

中档年货礼盒
¥368.00/礼盒

天天果园100元充值卡
¥100.00/1张

天天果园200元充值卡
¥200.00/1张

天天果园300元充值卡
¥300.00/1张

天天果园500元充值卡
¥500.00/1张

天天果园1000元充值卡
¥1000.00/1张

家庭量贩 更多 >

小巨净盒桔
¥49.80/1kg

智利甜心樱桃
¥49.90/500g

美国85号苹果 (巨无霸)
¥68.00/2个

佳沛新西兰奇异果 (巨无霸)
¥78.00/6个

长柄草莓
¥39.90/220g

美国红安瓻
¥69.80/8个

橙先生-18K (L)
¥68.00/2.5kg

云南紫葡萄
¥69.80/2kg

美国烟台苹果
¥69.00/20个

进口净盒香蕉
¥35.80/1kg

全球鲜果 更多 >

新西兰樱桃
¥218.00/1kg

伏地冈甜士苹果
¥49.90/6个

新奇士美国脐橙
¥39.90/6个

mini甜葡萄
¥25.80/1kg

伏地冈甜心樱桃
¥168.00/500g

墨西哥牛油果
¥39.90/6个

澳洲无籽蜜桔
¥43.80/2.5kg

海南金凤凰蜜瓜
¥29.80/1个

美国华盛顿甜红地球苹果
¥39.90/6个

新疆阿克苏冰糖心苹果
¥49.90/2.5kg

Figure 9: Example of fruit for sale on Fruitday.com

Case studies

This section analyses two examples of the effective use of novel packaging in the New Zealand horticulture industry. These examples reflect the emergent thinking in the New Zealand horticulture sector which is that growing quality fruit is one thing, but to be successful these products need to be reinforced and enhanced through strong brands and product identities (Beverland, 2001). Good packaging design is a strong way to set a product apart from its competitors and galvanise a product's identity in the minds of consumers (Bloch, 1995).

Rockit apples: apples in a tube

Rockit apples are a variety of mini apples developed in the Hawkes Bay and packaged in distinctive clear PET tubes. The perception of this small variety of apple which traditionally may not have had a high market value has been altered by combining a packaging format and marketing strategy to sell them as 'snack-sized apples' a 'natural, healthy, grab 'n go snack food. This style of packaging and marketing sits well within a modern market where work and lifestyle pressures are disrupting traditional eating habits, leading consumers to seek snack options (Hongyan Yu, Ann Veeck, & Fang (Grace) Yu, 2015).

This strategy of well-chosen packaging and a strong marketing message has proven to be successful in the global market place. Even though production is up 40%, producers are struggling to keep up with demand having sold out earlier than the previous season (NZ Business News, 2017). According to Austin Mortimer, GM of Rockit's parent company, "[Rocket apples] demonstrates how high-quality fruit can be positioned as a premium, value-added product." (Beech, 2017, p.1)



Figure 10: Rockit apple packaging retrieved from www.rockitapple.com and Rockit apples in wholesale market in Taipei

Kiwi delight cherries: premium cherry packaging

The Kiwi Delight is a luxury packaging format for premium cherries developed by central Otago cherry company Cherry Corp in response to the demand for premium Cherries for use as luxurious gifts in Asia.

In March 2017 I met with Reece Van Der Velden, Sales Manager for Cherry Corp, to discuss how and why this form of packaging was developed.

According to Van der Velden these luxury cherry boxes are the cream of the cherry crop, with 48 hand placed cherries which puts them at a higher retail value. The Kiwi Delight cherries boxes retail in the Asia market for \$100 and even with the high cost they have proven to be popular. Cherry Corp sold 2000 Kiwi Delight boxes in the lead up to the 2017 Chinese New Year which is an important time for gift giving (personal correspondence, Reece Van de Velden 6-03-2017).

In the same year (2017) Cherry Corp also tried to sell the luxury cherry boxes domestically, but this proved to be unsuccessful. Van der Velden mentioned that even though the company tried to sell it in New Zealand at the reduced price of \$39 it was still criticized by consumers for being extravagantly priced for the amount of fruit it contains (personal correspondence 6-03-2017). This is reflective of the differences in attitudes between New Zealand consumers and Asian consumers with respect to the perception of the value of these types of products.

For Cherry Corp it was important that the packaging for these cherries conveyed and reinforced the premium quality status of the fruit and had a luxurious quality, while at the same time protecting and preserving the fruit. For this reason, the packaging was designed in-house to meet the company's specific needs in relation to the intended consumer base (personal correspondence 6.03.2017).



Figure 11: Kiwi Delight cherry packaging

Summary of key findings

Through this research I have explored the importance of well-considered packaging for fresh berry fruit from both the standpoint of protecting and preserving the fruit as well as engaging consumer's and enhancing their overall experience of the fruit. I examined how kiwiberries are currently packaged for export, as well as current packaging manufacturing processes. I identified broader characteristics trends that influence consumption and consumer behaviour toward fresh fruit in the Asian market. Some of the key finding include:

- Rising consumption of high quality imported fruits among the middle class in Asia, and the general positive perceptions and trust of food coming from New Zealand (Qing et al., 2012).
- The role social, cultural and symbolic values have on fruit consumption habits in Asia, with specific respect to the practice of giving premium quality fruit as a luxury gift.
- The changing retail landscape in Asia and the increased integration of online food retail services and supermarket's experiences. (Russell, 2017).
- A greater move within the horticulture industry in NZ and internationally towards turning fruit into branded customer focused food products rather than just raw commodities utilising packaging to create stronger product identities (Beverland, 2001).
- Sensorial elements of packaging design like colour, shape and texture influence a food's desirability and can even have a positive influence on the eating experience (Hendrik N. J. Schifferstein et al., 2013).
- Trends towards fruits being packaged and marketed as convenient, healthy snack foods, and producers adding value through recognisable brands.

These finding were validated for me through discussion with professionals working within the Kiwiberries and wider horticulture industry here in NZ and in Asia.



Chapter 4

Design Process:

Discovery phase

Engaging with the Institute of Food Science and Technology

As well as observing the packing process, an essential part of this research involved engaging with the Institute of Food Science and Technology. Several trips to Palmerston North were taken to meet with my co-supervisors Dr Eli Gray-Stuart, Lecturer in Packaging Technology, and Associate Professor Dr Andrew East. These meetings helped to form key understanding around the science and technologies involved in packaging fresh fruit. My co-supervisors were also extremely helpful in introducing me to professionals in the horticulture industry who furthered my research. Along with meeting with my co-supervisors, these visits enabled me to meet with fellow masters and PhD students working on various projects in the field of post-harvest research. This was a good opportunity to compare notes and discuss the cross over points of our projects and the approaches of our different disciplines.

The pack houses and packing process

Primary research into how kiwiberries are currently sorted, packed and stored was conducted through site visits to two pack houses in Te Puke. This allowed me to see first-hand in fine detail all the steps of the process the kiwiberries go through as they are sorted, graded and packed into the current clamshell punnets. These observations highlighted the necessity of packaging formats being compatible with the packing system used. In this process human labour is used to remove defective fruit (see fig 11, p.35) and to monitor the conveyor and loading machinery and to intervene where necessary to ensure the process runs smoothly and the fruit is packed properly (see figs 12, 13 & 14, pp. 35-36). Findings from these observations helped to guide thinking around some of the technical detailing incorporated in the final prototype.

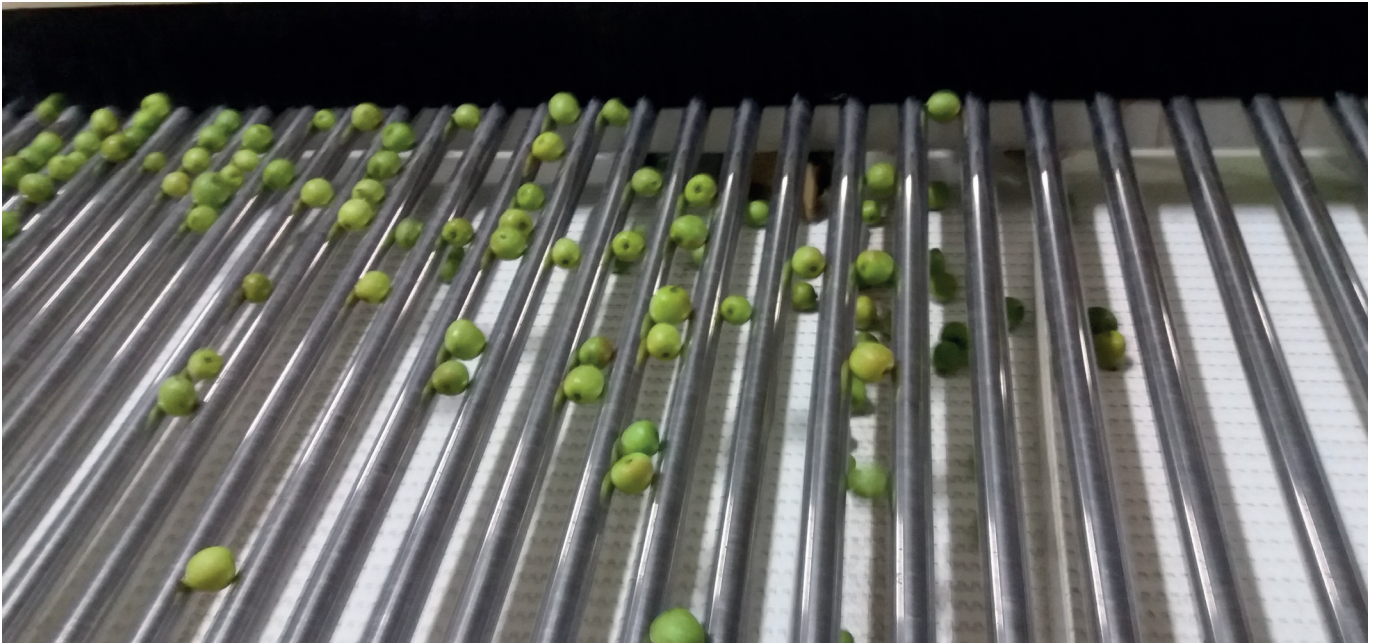

Figure 12: Machines sort kiwiberries in two size categories with the larger being export grade



Figure 13: Quality control, defective fruits are manually removed

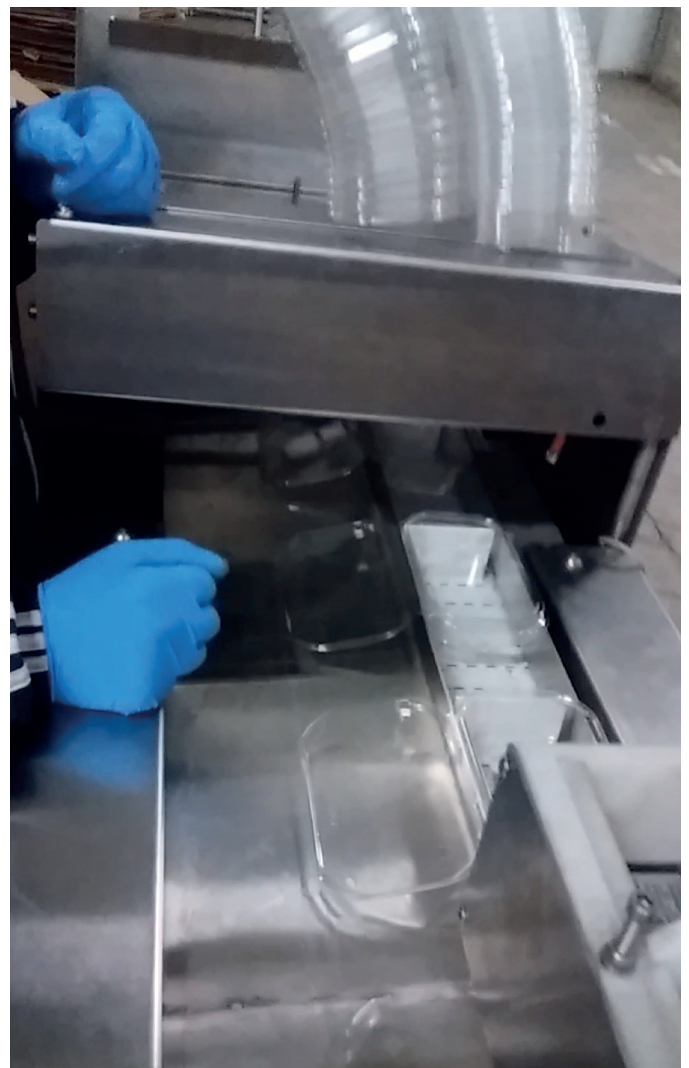

Figure 14: Clamshells being mechanically placed on loading conveyor



Figure 15: Kiwiberries being loaded into clamshells and manually shaken to settle the berries



Figure 16: Stickers being placed on clamshells



Figure 17: Clamshell punnets stacked in packing trays

Reflection on field research in Asia

Taipei and Singapore

The field research in Singapore and Taipei formed the backbone of my qualitative research and provided vital insights into the market environment and the way fruit is perceived, represented, presented and consumed.

During this trip I documented the visual and material style of packaging in general to better understand how food products are presented in these markets. Specific attention was paid to packaging of the fresh fruits, particularly berry fruits. As well as packaging, I looked at the visual and material qualities of the shopping environments. According to Qing, Lobo, and Chongguang, the retail environment is an important factor in influencing consumers' perceptions when purchasing fruit.

Key observations and insights from this trip were:

Kiwiberries are still a niche fruit with a price premium sitting around (NZD) \$6,\$7 per 125g punnet. They are sold in more upmarket supermarket chains such as Jason's Market which sell almost exclusively premium imported fruit. According to Shermaine Tan (Business Development Manager at Tian Sheng Fresh Produce Ltd, Singapore), these markets serve a more affluent segment of the market, and the products and material presentation of these shopping environments reflect this (personal correspondence, April 2017).

There were a lot more fruits and vegetables that came in some form of packaging compared to New Zealand, particularly fruits and vegetables I don't normally associate as being packaged, e.g. apples and pears. I noticed a lot of packaged fruits came in evenly arranged numbers (refer to fig 20 pp. 40,41).

Premium or luxury style packaging for highly priced fruits such as strawberries, cherries, rock melon and specific varieties of apple were commonplace in the more up upmarket supermarkets (see figure 4 and 5 pp 24,45). This reinforced findings from literature and interviews around the practice of giving premium fruits as gifts.

Another example of this cultural phenomenon is that boutique fruit stores cater to the gift giving practice by selling high quality expensive fruits and even providing pre-packed gift packs. This was observed first hand in Taipei (refer to fig 18 p.38).

Along with more luxuriant style packaging, I also observed that packaging tended to take a fun playful tone with bold colours and cute anthropomorphised characters (refer to fig 20 p.40) This is a strong demonstration of the *kawaii* (Japanese for cute) aesthetic which appears widely in east Asian pop culture and marketing (refer to figures 20 pp. 40,41) (Hung, Li, Belk, Hung, & Belk, 2007).

Although the supermarkets in Taipei and Singapore don't differ greatly from to those of New Zealand in terms of lay out, it was the attention to detail in the way fresh fruit was presented to consumers that really stood out for me. The range of colours and packaging of the fruit products formed a feast for the eye that I have not experienced here in New Zealand.



Figure 18: Boutique fruit store in central Taipei



Figure 19: Example of store owners adding additional packaging to protect fruit



Figure 20: Examples of fruit packaging and displays from supermarkets in Taipei and Singapore



莓類世



Semi-structured consumer survey

During the research trip to Singapore and Taipei a consumer survey was conducted. Twelve participants took part; five in Singapore and 7 in Taipei. The aim of the survey was to gain candid insights from consumers in both locations regarding the relationships between individuals and packaged fruits. These semi-structured surveys took place in busy shopping districts in close proximity to supermarkets that sold kiwiberries. Participants were a mix of genders and ranged in age from early 20s to early 60s. The questions in this survey focused around two key areas: how, or if, packaging played a role in their perceptions of berry fruits, and what effect that had on their purchasing and experience of these fruits; and what was their level of awareness of kiwiberries, including their thoughts and impression of this fruit. From this survey and subsequent discussions key themes emerged (outlined below) which helped shape the kiwiberry packaging design criteria and elements of the later design process. Full copies of the survey are in appendix 3A to 3K pp.90-125.

Summary of findings

Colour is an important signifier. Most participants had not come across kiwiberries before and perceived them to be sour or unripe due to their green skin. Kiwiberries are still a new, novel fruit, and it's not immediately obvious what they are and what they taste like. Only one of the 12 participants had actually eaten a kiwiberry. They described it as being an enjoyable experience and would eat them again if they saw them in the supermarket. For the rest of the participants, the characteristics of kiwiberries were described (i.e. it being part of the kiwifruit family) and a photo was shown. Once participants knew more about the fruit, its size and smooth skin, participants commented it was more appealing and it gave the impression of being more convenient to eat than the larger green Kiwifruit.

Aesthetics and the quality of packaging was important in choosing a berry product, and engaging eye pleasing packaging would make participants more likely to investigate a new product. Freshness and quality were very important to participants, and having reassurance of quality was desirable. These findings, along with supporting literature, helped to clarify some key areas of design research.

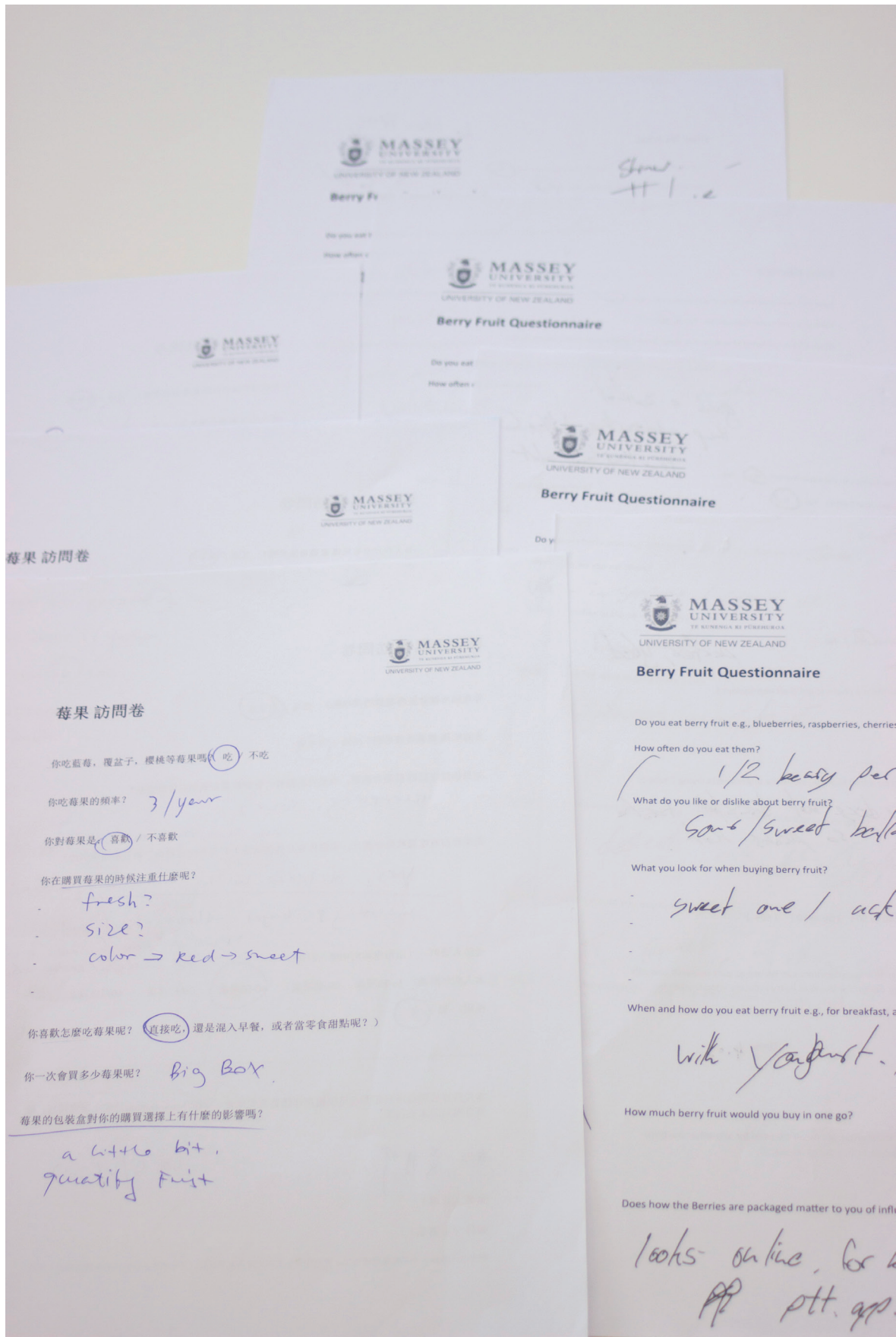

Figure 21: Consumer surveys

Hong Kong: Fruit Logistica Asia

The field research trip to Hong Kong in early September was to attend Fruit Logistica Asia (2017). This was a four-day event which included the Asia Fruit Congress, a one-day conference exploring the larger industry trends of the international fruit trade in Asia. The rest of the event was a three-day trade fair with a total of 813 exhibitors showcasing fresh fruit products as well as products and services associated with the fresh fruit trade. Fruit Logistica Asia is a major annual event for those involved in the fruit trade; I was one of over 13000 attendees from 79 countries (www.asiafruitlogistica.com, 2017). This event gave me a unique insight into the broader workings of the fresh fruit trade and some of the more interesting innovations starting to emerge in supply chains, marketing and retail sectors.

The emerging trends in marketing and retail highlighted in the contextual review (such as fruit being more of a consumer product rather than a commodity) were acutely demonstrated in the packaging and visual representations of fruits and brands on display. A lot of these representations took on a very bright playful tone which was in keeping with packaged fruit products I had observed in the markets in Taipei and Singapore (see fig 20, Pg. 40).

In regard to the supply chains, from what I observed and heard (from key note speakers), there is a greater push toward total supply chain transparency. Increasingly sophisticated data management systems utilising block¹ chain and 'smart packaging' are enabling producers, shipping companies and retailers to better

co-ordinate. This means produce is getting to consumers quicker with greater control over food safety



Figure 22: Me with Zespri mascots at Asia Fruit Logistica Asia 2017

Figure 23: Following page examples of product displays and marketing from Asia Fruit Logistica Asia 2017

¹ "blockchain technology is a way of storing and sharing information across a network of users in an open virtual space. Blockchain technology allows for users to look at all transactions simultaneously and in real-time. In food, for example, a retailer would know with whom his supplier has had dealings. Additionally, since transactions are not stored in any single location, it is almost impossible to hack the information" (Charlebois, 2017, p. 1)



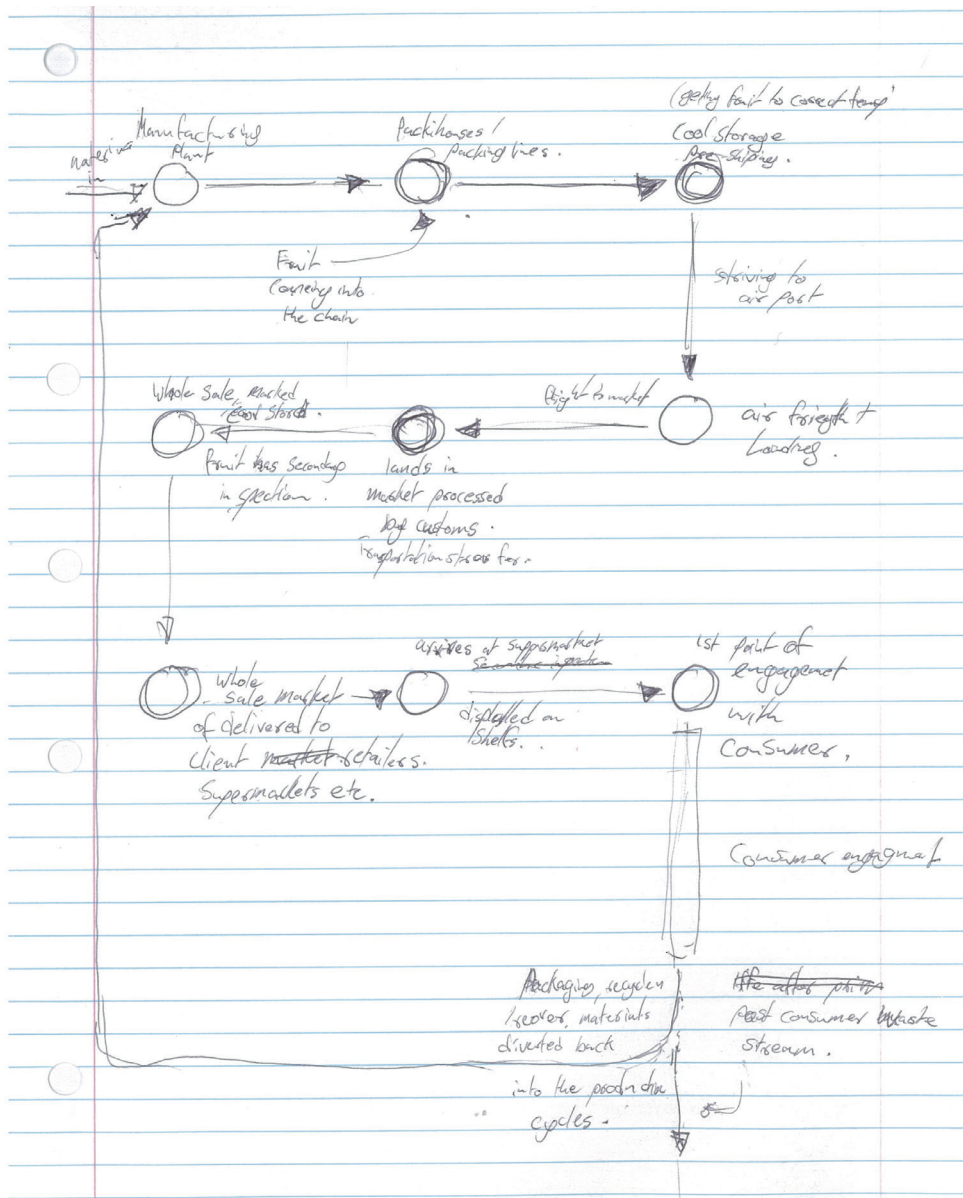

Figure 24: Mind maps of the supply chain and key considerations.

Defining phase

Journey mapping

Due to the complex requirements the packaging needs to fulfill at different stages of the product journey, it was necessary to map this journey out to better define the design requirements. The life cycle of the packaging was mapped out with each node accounting for a key environment, integration and process the packaging goes through. Each one of these stages poses a set of design challenges and potential opportunities that need to be considered within the ideation and development phases of the design process.

Two journey maps were created. The first journey map (fig 24) focuses on packaging production and the cool-chain, and the second journey map (fig 25) focuses on the consumer interaction with the packaging.

The first journey map was used as a tool to plot out the technical requirements the packaging design would need to address. This helped to define elements of the design criteria. The second journey map was used as a tool to plot out and better understand the different stages of interaction a consumer has with the kiwiberry and its packaging. This was used as a framework from which to investigate the different design elements that contribute to the overall consumer experience of kiwiberries as a total product.

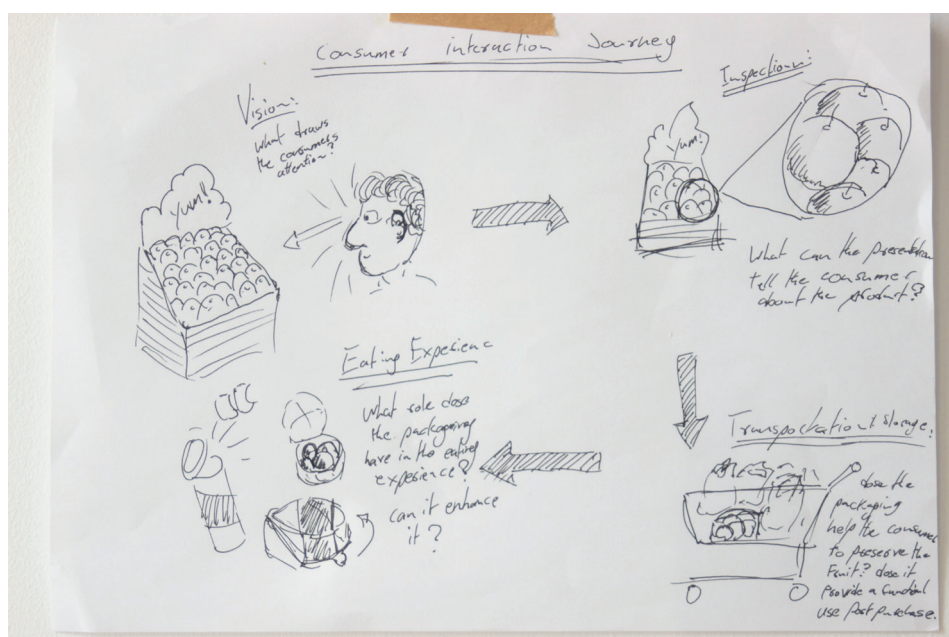

Figure 25: Consumer interaction journey map

Design criteria

The design criteria are used as a framework to guide the development of the packaging design.

Presentation

As an object, packaging needs to capture a consumer's attention and display the product in a desirable way. Visual and form details should be utilized to maximise the appeal of the kiwiberries as well as considering the aesthetic sensibilities of the market in Asia.

Product experience

It is important that both visual and functional elements of the packaging work together to enhance the consumers' overall experience of the kiwiberries. The packaging should be easy and intuitive to open and as well as offering a convenient format that adapts to different eating habits.

Keeping up with market forces

The packaging must take into consideration evolving retail and consumption trends of fresh fruit products in Asia. These include integration of digital and physical retail experiences, snack packing and an increased emphasis on fruit brand identities.

Protection and preservation

Preserving the quality and freshness of kiwiberries is a vital function of the packaging. Optimising the physical protection and atmospheric conditions of the fruit must be addressed in the packaging design.

Supply chain

It is important that packaging utilises space well and can be stacked efficiently to minimise exporting costs. The design also needs to take into consideration limitations around existing equipment and the setup in pack houses, as well as adhering to food safety standards as set out by the Ministry of Primary Industries.

Development phase

Initial design development explorations

Replica fruit

Kiwiberries are a seasonal fruit which meant I only had access to the fresh fruit from late February to early April. I needed a way to test out my packaging concepts later in the design processes when I knew I wouldn't have access to the fruit. In mid-March, I created silicone moulds of some kiwiberries which enabled me to cast multiple replicas of the fruit. The replica fruit were cast in silicone and dyed green to give a likeness to fresh kiwiberries.

This material did not perfectly mimic the weight and texture of the fruit's skin; however, having replicas of the fruit that mirrored their size and shape proved to be invaluable in testing out design concepts.



Figure 26: Silicone casts of kiwiberries and moulds

Material explorations

In the initial design stage I looked at what materials would be most suitable to use in the packaging of kiwiberries. The main materials looked at were card and cardboard products, moulded paper pulp, PLA (polylactic acid film) and expanded PLA foam, and PET/ R-PET (recycled PET). These materials were chosen as they are currently used in different applications of packaging fresh produce and have a track record as being food safe and economically viable (Brunazzi et al., 2014). These materials were incorporated and combined variously in many sketch models and prototypes (fig 36 p.58). These experiments demonstrate the different materials' physical and sensorial qualities. Ultimately, through my research I concluded that for a fruit like the kiwiberries the packaging material that was most suitable was still PET in the form of R-PET. It should be noted that while this research project has investigated 'sustainable' efficacy around materials, it was not the primary focus of the research outcome and thus it is not elaborated on within this thesis.



Figure 27: Material explorations with moulded fibre, PLA foam and thermo-formed plastics

Figure 28: Material explorations with moulded fibre, cardboard, PLA foam, polystyrene and thermo-formed plastics

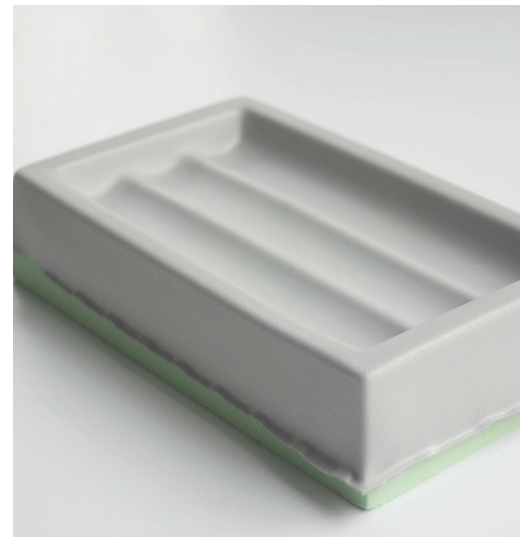

Colour and composition explorations

This area of inquiry was based around findings from literature and primary research that indicated that the colour of packaging and physical arrangement of fruit can positively influence the overall product experience. These explorations took a more qualitative approach and the purpose was to experiment with different visual displays of fruit.

Different colours and tones were looked at to see how they might interact with the green of the kiwiberries to enhance the visual appeal of the fruit (fig 30).

Explorations of compositions were conducted where different fruit were displayed in a more formalised way (fig 29). The purpose of these experiments was to explore the impact that a more ordered composition might have on the sensorial experience of kiwiberries. Although it is difficult to accurately test these ideas without doing more in-depth analysis using actual kiwiberries, these explorations still proved to be a useful exercise. The explorations provided key insights that were then incorporated into the concept developments.





Ideation stage

In this stage of the design process, sketch models were used to explore a wide range of ideas. The physical act of making was employed as a method to enable me to experiment with a range of materials, forms, construction methods and production processes. These initial explorations formed the foundation upon which to evolve more resolved concepts. Ideas were generated freely without focusing too greatly on practical limitations, at least in this early phase.

In this initial phase, a number of ideas were explored in relation to findings from primary and contextual research. I developed ideas and a concept with a focus on one or two functional or experiential elements that the packaging design should address, such as the structure, texture and form.

This strategy enabled me to explore potential ideas and solutions around specific requirements that grew out research findings. For example, my exploration into using flexible film that could be printed on was in response to conversations had while visiting the pack houses in Te Puke. Chris Dunn, packhouse manager at East Pack, indicated that putting stickers on the punnets of kiwiberries could cause problems if the sticker machine was not functioning properly (personal correspondence, 8-3-2017). This led to the design question: how would I design packaging that took adding a sticker out of the process? These initial ideas which explored different facets of packaging (form and material structure) were then reviewed to see what was working and what wasn't. The elements of these early ideas that were successful were cross-pollinated and amalgamated to see how many aspects of the design criteria could be addressed in single concept (fig 24 pp.55, fig 36, pp.58,59)

From the initial sketch models four initial packaging typologies were developed. Early prototypes were developed loosely based on these four typologies. I titled these four typologies: , The Jaws (fig 32, p.56), The End Caps (fig 33, p.56), The Slider (fig 34, p.57) and The Rows/ Egg carton (fig 35, p.57) Most of these early packaging concepts were iterations of one of these typologies, or a hybrid of two typologies (see fig 36 pp.58,59). Four test models from the four typologies were presented to project stakeholders from Zespri (Carol Ward, Innovation General Manager, Kylie Phillips, Innovation Leader) and Freshmax (Tracy Burns, Export Manager). At the end of this presentation a structured discussion and critique of the concept proposals was held. This industry feedback validated some of the key ideas that had been developed up to this point and from there the scope of design development was focused further.

Figure 31: Initial ideation sketches and models

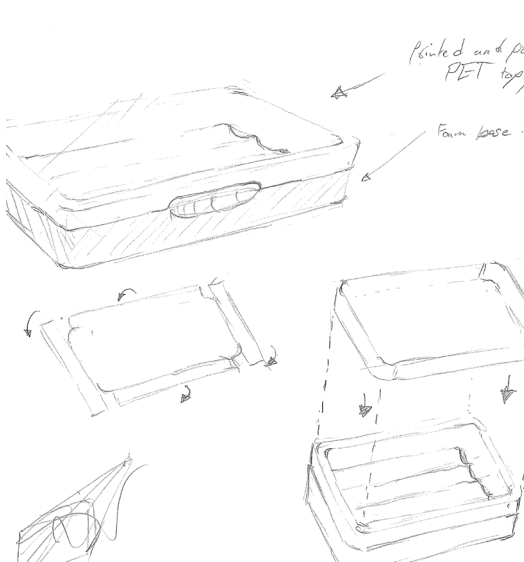
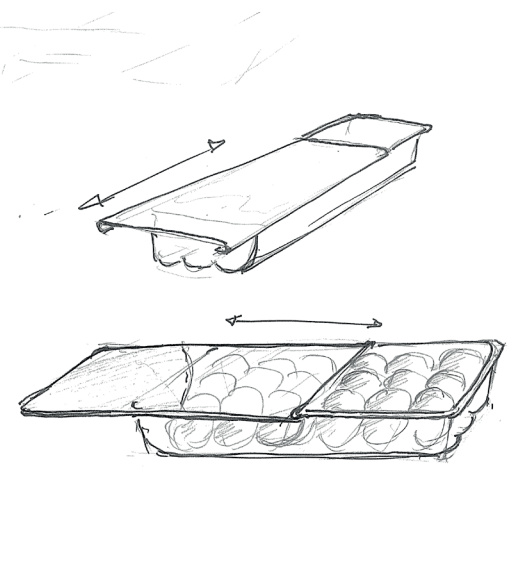
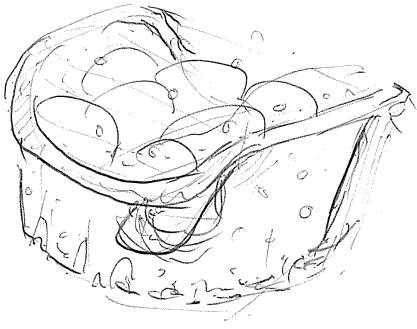

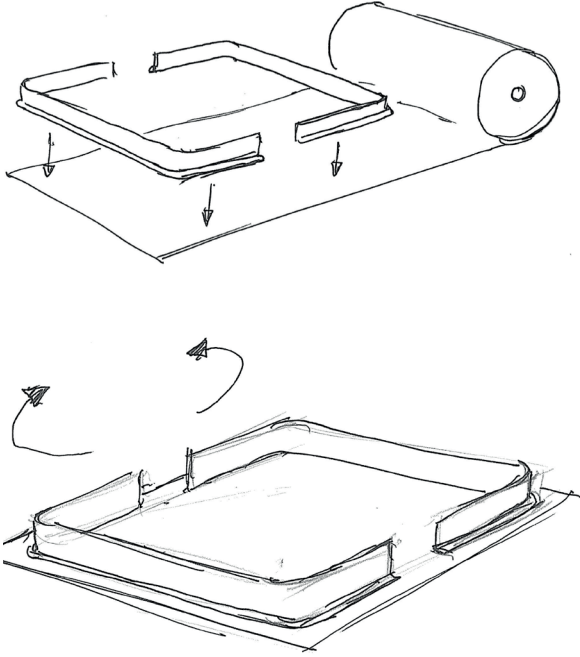

Figure 32: The Jaws concept combines a flexible film with rigid cardboard structure.

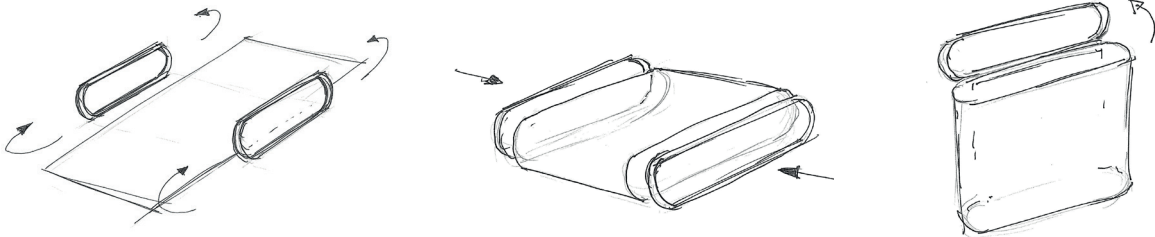

Figure 33: The End Caps concept combines flexible film with thermo-formed caps.

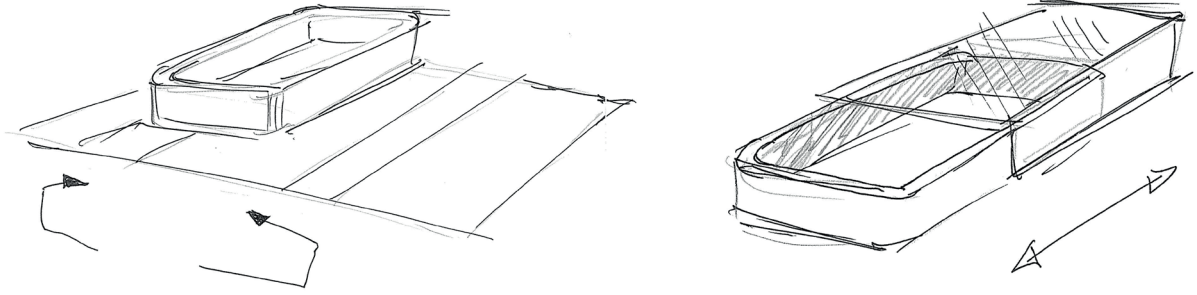
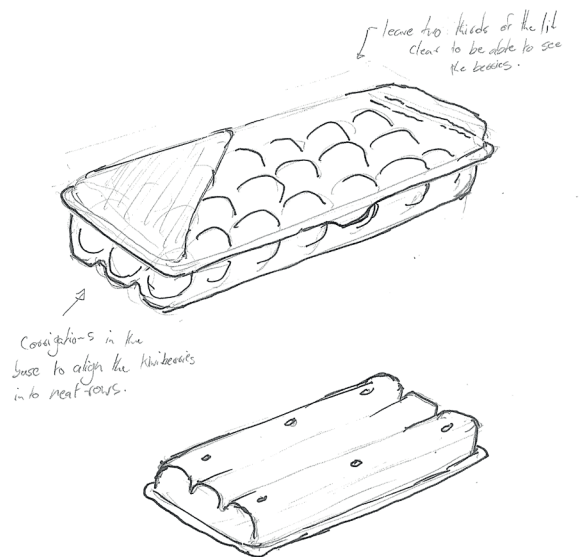

Figure 34: The Slider concept is a foam shell in a flexible film sleeve.



Figure 35: The Rows / Egg Carton concept, this concept explores the use of dimples to orderly arrange kiwiberries with a specific number of fruit. Note 8 is a lucky number in Chinese culture.



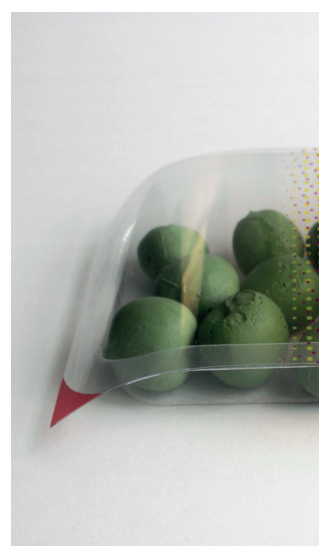
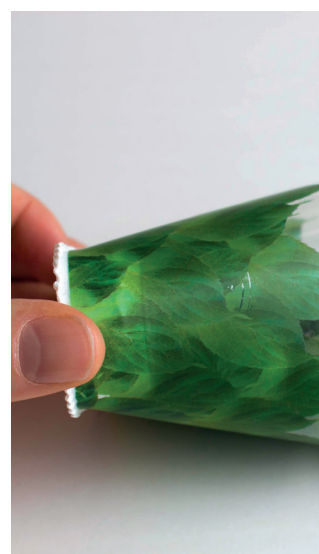
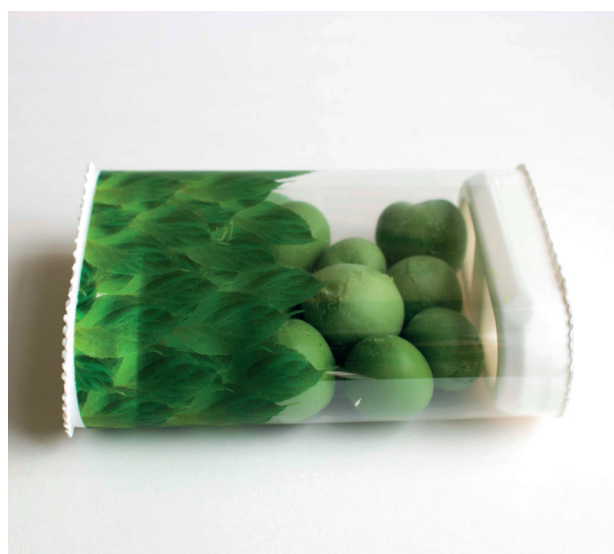
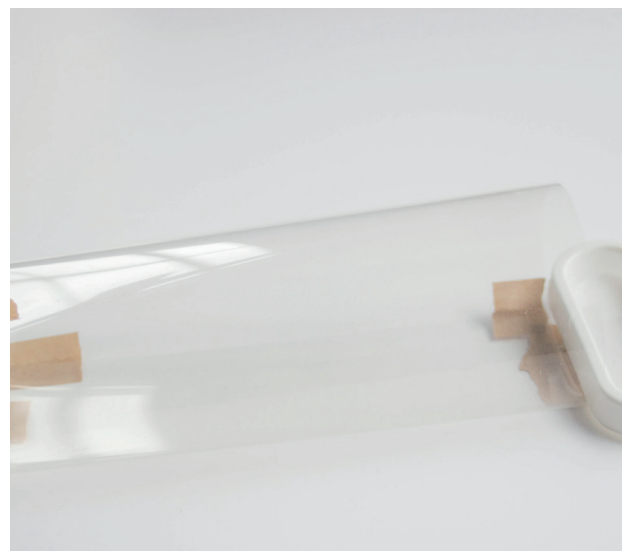
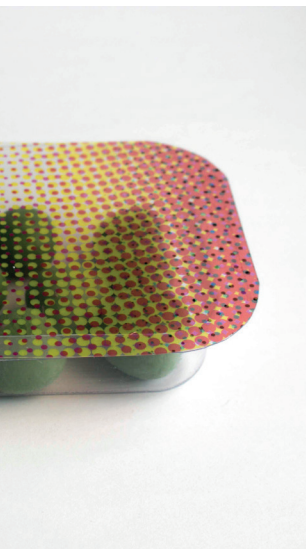
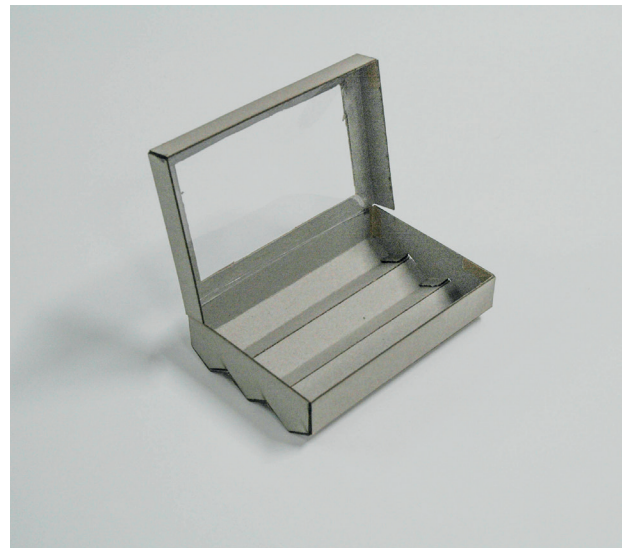

Figure 36: Sketch models of different iterations on the four main concepts shown on the previous page.





Prototype 1: Film with ribs

Concept one explores a more experimental idea that deviates from current packaging formats and creates a bold new approach to packaging with a greater emphasis on stylised form. Through this concept I wanted to explore how a new format of packaging could be produced. It was a follow-on from earlier explorations where I considered combining hard and flexible elements. The central idea behind this concept was to create a packaging format that felt very light and framed the fruit in an elegant way while still being rigid and strong enough to stack one on top of the other.

This design consists of two base elements: the flexible film and the rigid ribs which create at either end a clean cylinder. The colour and stylised patterns give visual interest and nicely frame the fruit.

The film would be pre-printed with graphical elements, then die cut. The film sheet would then be pressed and formed around the ribs and then heat bonded in place. The film is folded into grooves on the bottom to give extra rigidity.

Injection moulded ribs use only the minimum material needed, and provide an opportunity for the area of the voids to be optimised to give the most desirable air flow for cooling and atmosphere inside the container.



Figure 37: Concept 1: Film with ribs with different rib patterns

Figure 38: Folds in the film create extra rigidity along the bottom of the packet

Prototype 2: Sealed shell

This concept explored designing a packaging format that is highly functional but would also stand out and be engaging. The driver behind this concept was looking at how to utilise currently available packaging technologies and manufacturing processes together with design sensibilities to give more aesthetic meaning and value. Attention was given to how details in form and colour could enhance the display of the kiwiberries in the supermarket environment.

A thermoformed R-PET (Recycled-PET) tray is combined with a clear re-sealable film lid with interlocking tabs at each end of the sheet (see bottom of fig 39). The R-PET tray is formed in such a way that when the film is sealed around the rim of the tray a curved bend in the film is formed along the front edge (fig. 39) The intention behind this is that the film provides a clear surface through which to see the fruit, and the sweeping curve is a detail that creates visual interest and aims to draw in the eye of the consumer. The curve also allows the kiwiberries to be seen from a shallower angle if stacked on a produce shelf at eye level.

This type of resealable film would have clear signifiers such as tabs to enable the consumer to peel it back to get access to the fruit and re-seal to protect and preserve any remaining fruit. This concept comes in two versions, a standard pack and a twin split pack. The twin pack would be scored through the centre to allowing the packaging to be snapped in half to create two 'snack-sized' packs. Though this packaging concept does not deviate greatly from the norm of current packaging, it endeavours to use carefully considered details to set itself apart and attract consumers attention.



Figure 39: Prototype 2: Sealed shell

Exploration into packaging as a system

Digital engagement: Prototyping

Unique QR codes incorporated into packaging open a digital space for further consumer engagement. Using a mobile web platform is a great way to display product information in a clear, accessible way. Findings from contextual research show that this type of digital engagement is becoming an increasingly common part of the consumer experience.

In response to these findings I explored augmented reality as an interesting new platform to engage consumers in a highly tech-saturated market. The intention behind this exploration was to experiment with a more playful gateway to inform consumers about kiwiberries and as a bold strategy to develop a product identity.

As an element of consumer engagement this was not incorporated into the final design as it fell outside the core scope of this project. However, it is important to mention as it highlights an interesting format to communicate with customers which could be explored in further research that may be relevant to the industry.

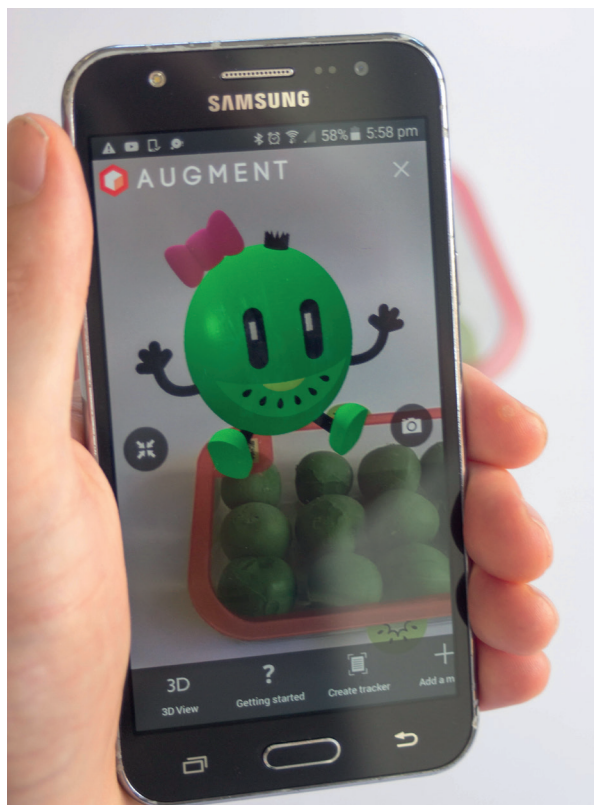

Figure 40: Prototype augmented reality *kawaii* character icon.

Gift pack: Prototype

This prototype explores secondary packaging ¹that displays and houses three kiwiberry trays that offer the consumer a greater number of berries in a convenient and attractive carry case. This pertains to the practice of giving fruit as gifts, as highlighted in the contextual review, as well as proposing it as an attractive promotional tool.

Sketches and an initial sketch model initiated a mock-up in CAD to evaluate an ideal stacking configuration. More resolved cardboard prototypes were created and tested with the primary packaging prototypes to evaluate its look and physical dimensions (see fig 41,42 pp.66,67). The design meant that it could be assembled and held together without glue. I used the sketch models and prototypes to investigate how to best configure the tabs and folds.

It is not intended that this secondary packaging be used extensively, but used in targeted retail situations to explore a more ritualised experience of the kiwiberry. I believe that combining secondary packaging and primary packaging with a clear common design language can create a distinct unified product identity around the kiwiberry.

1 Primary packaging refers to the kiwiberry packaging itself, and secondary packaging refers to the supplementary cardboard carrycase packaging that forms gift/multi pack. In the case of this document, tertiary packaging is the term used to describe the cardboard trays into which the primary packaging is loaded before the trays are stacked on pallets ready for storage and shipping (refer to fig 17, p.36).



Figure 41: Prototype multi-pack carry case

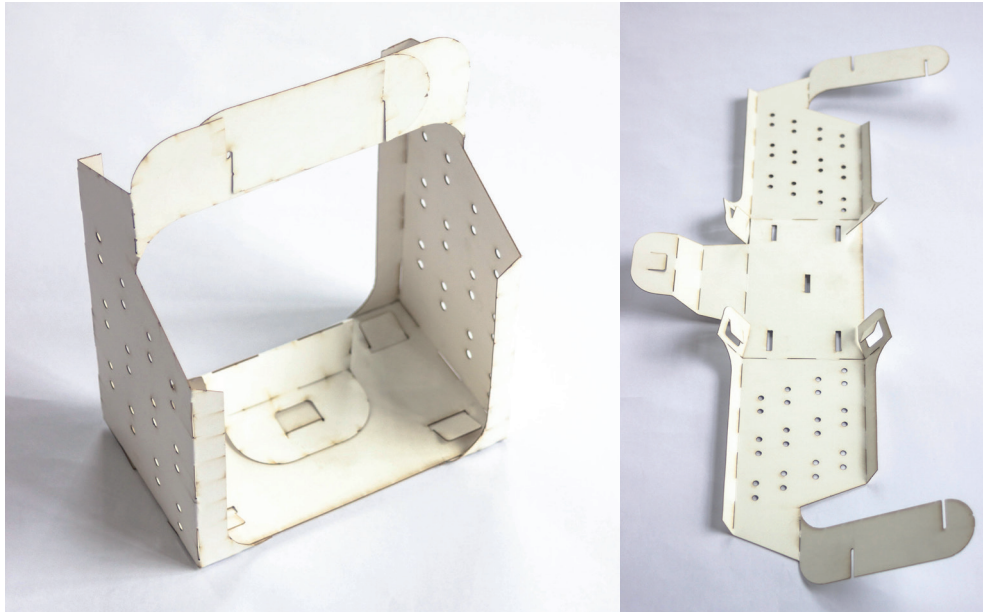

Figure 42: Prototype multi-pack carry case technical iteration

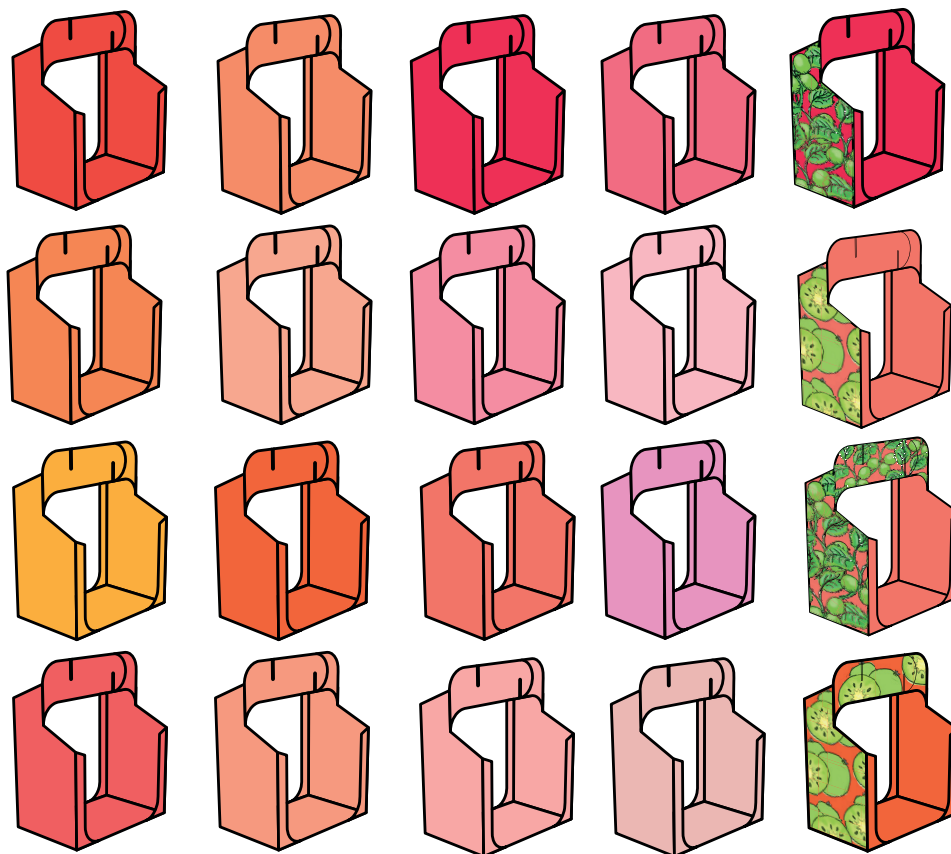

Figure 43: Exploration of multi-pack colorways and graphics



Chapter 5

Final design

The final design output needed to propose an innovative packaging solution that would be grounded enough to satisfy the current scale and capabilities of the kiwiberry industry. Ultimately, I concluded that the final design should not just be one object. Instead the design should work as a system to give the kiwiberry industry greater flexibility to address different consumption trends and to develop the product identity.

Kiwi-Pack three-tiered packaging system

The Kiwi-Pack system is made up of two primary packaging components and a secondary packaging component. The two primary packets consist of:

- A standard pack which holds 12 neatly aligned fruit.
- A twin snap pack that split to create two snack sized packets.

The secondary cardboard packaging makes a convenient carry case to hold and displays three primary packs. The carry case design is intended to be used as a promotional gift pack. The three packaging typologies working in conjunction make an interchangeable packaging solution.

Figure 44: Kiwi-pack packaging system



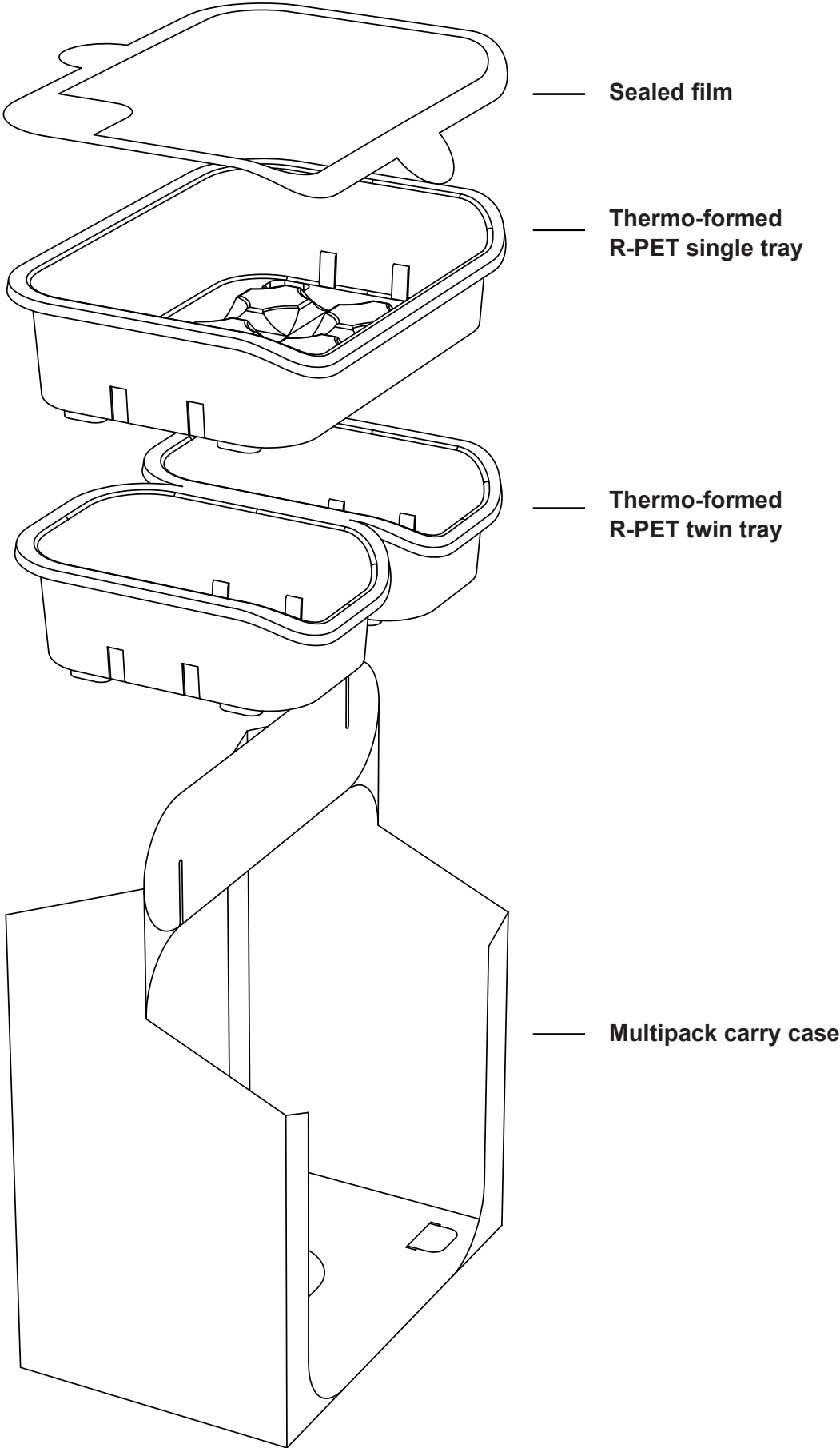

Figure 45: Kiwi-pack packaging system components

Thermo-formed R-PET tray

- Curved lip creates an elegant form detail which enables the fruit to be seen from shallower angles as well as enhancing space efficiency.
- The dimples orientate the fruit in a neat composition and allow for greater airflow and are a preventative measure against fruit bruising from being in contact with each other.
- Foot details to enable airflow across the bottom of the packs and to provide more uniform cooling in storage after packing.
- Anti-coupling details: this is a detail that is incorporated into a lot of thermo-formed packaging to prevent them from compressing and locking together causing jams in the packing machines.



Figure 46: R-PET shell component



Figure 47: Anti-coupling details

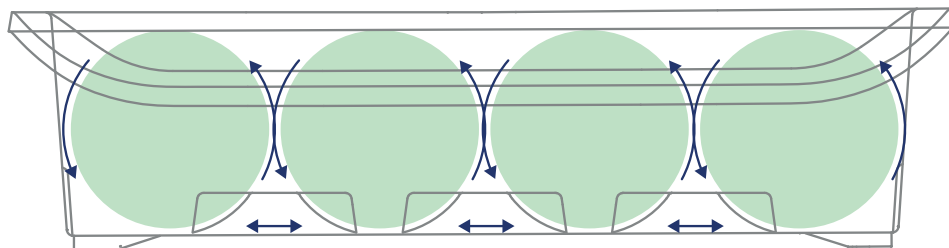

Figure 48: Diagram of airflow around the kiwiberries



Figure 49: Re-sealable lid and tabs hooking lid in place

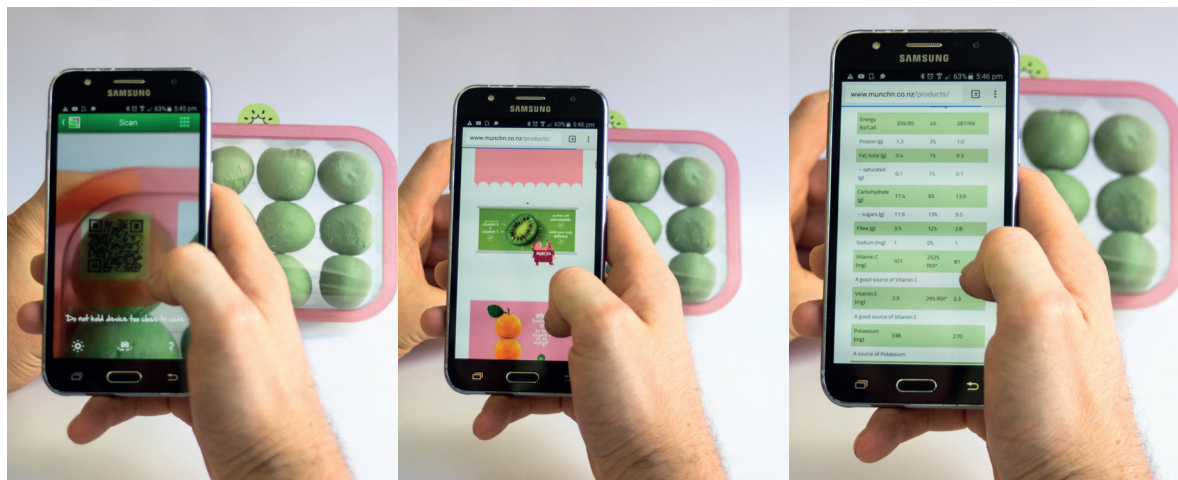

Figure 49: The unique QR code links to product website with information about the kiwiberry such as nutritional information as well as being used to track the product during the supply chain and verifying the point of origin

Sealed film

- The resealable film maintains optimal atmosphere around the fruit to extend shelf life.
- Tabs make it easy to peel back and can be hooked back in place to give access to the fruit.
- Digitally printed with a unique QR code for supply chain tracking, as well as being a link for consumers to access product information .
- Digitally printed graphics frame the fruit with a complimentary red hue to enhance the visual perception of the fruit.
- This sealed film provides the opportunity for modified atmosphere packaging (MAP) to be used in the packing process (refer to foot note on p. 19).

Twin snap-pack

- Scored for easy snapping.
- Creates two separate resealable snack packs.

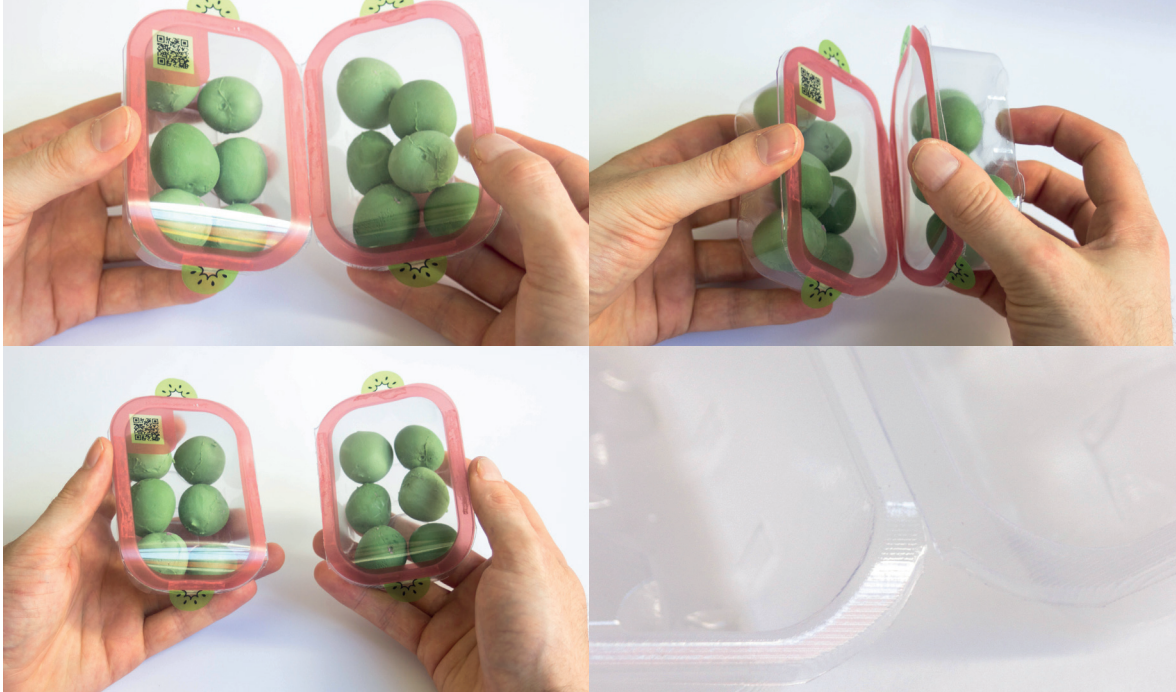

Figure 50: Twin pack being snapped into two halves

Multipack carry case

- Creates a nice display with packs angled for optimal viewing.
- Offers the industry a promotional platform that is unique and stands out in a supermarket environment.
- The carry case is folded and held together with interlocking tabs with no glue needed. This allows the carry case to be transported flat and assembled in market for promotional displays of for boutique fruit stores.



Figure 51: Secondary packaging

Design refinement process

Form refinement

I created preliminary form studies using 3D modelling software to quickly conceptualise some of the more complex three-dimensional elements. These models were used to test out optimal sizing, volumes, and stacking configurations as well as experimenting with the forms to arrange the fruit uniformly. Each 3D model became a refinement on the last, with different technical details being tested and discarded or refined.

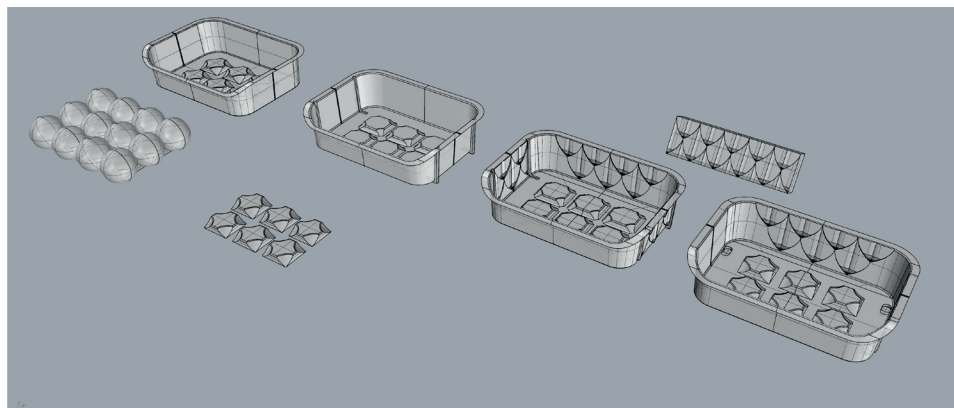
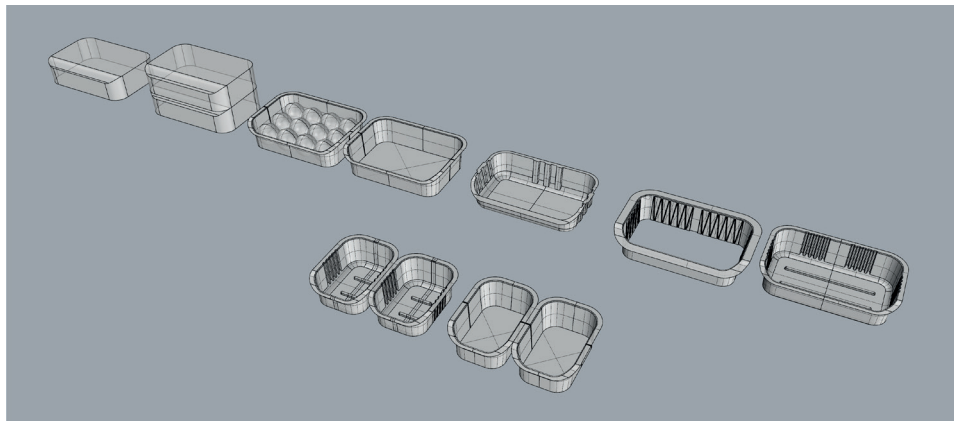

Figure 52: CAD models of form explorations and dimensional refinements

Figure 53: Experimentation with form detailing as a way of increasing rigidity as well as adding visual interest

Space efficiencies

One important element of packaging kiwiberries is space efficiency: utilising available space to maximise the amount of fruit that can be stored in the tertiary packaging (see fig 54). This design addressed packing efficiency by utilising space that current packaging does not take advantage of. Two design features allow better utilisation of space. The first feature is bringing the edges of the tray in and compressing the total cross section depth of the tray wall by creating a tighter draft angle. The second feature is the curved lip along the front of the tray which allows the trays to sit tighter together (see fig 56) allowing this tray design to be longer and increasing the space for fruit. Although the overall footprint of this design is larger, being 1mm wider and 6mm longer, the same number of packets can be stacked in the secondary trays. This slightly larger tray format can easily fit 12 large kiwiberries, two more than the current packaging, meaning roughly a 20 percent increase in capacity (see fig 55).



Figure 54: Packing configuration of primary packaging in tertiary packing tray

Figure 55: Fruit capacity of current clamshell holding two fewer kiwiberries than the Kiwi-pack design

Figure 56: Space efficiency of Kiwi-pack design compared with current clamshell package

Tactile elements

As the lid of this packaging design is a sealed film, tabs are used as a physical and visual signifier for how it is to be opened. Different tab configurations were experimented with, and through this process I evolved the idea of using a tab as both a means of pulling back the sealed film and of holding the film in an open position by utilising two tabs that could hook together.

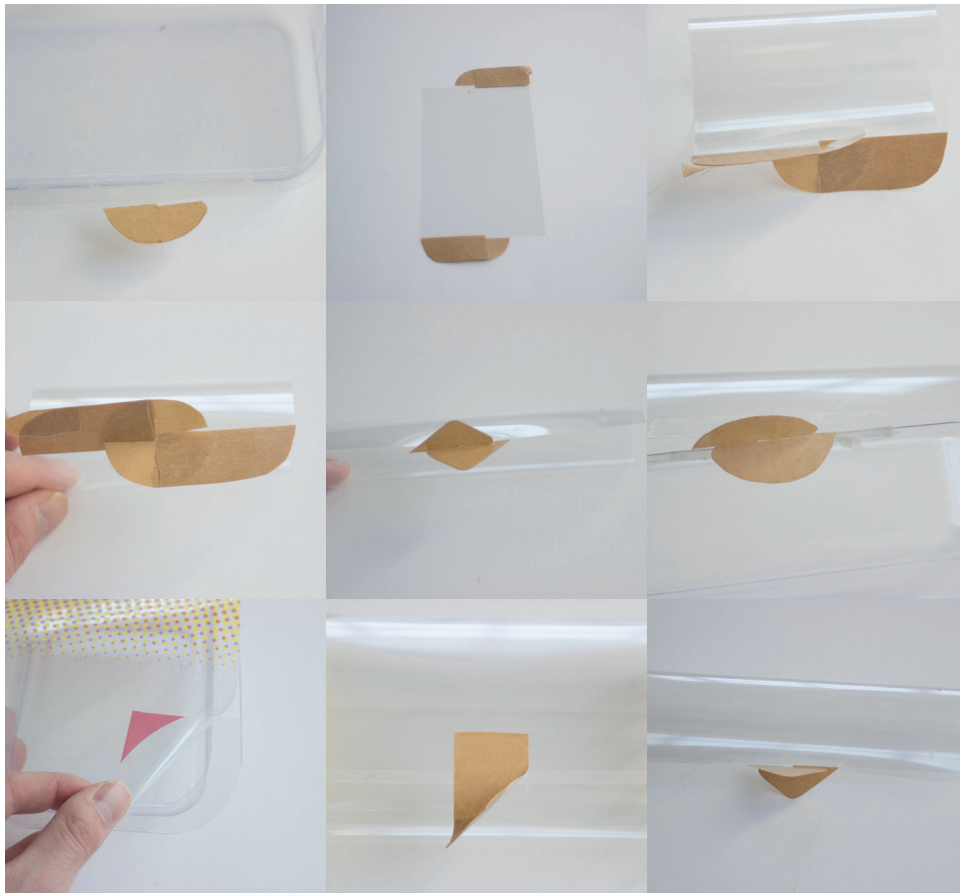

Figure 57: Iterations of tabs and opening function of sealed film

Prototyping thermoform moulds

Through using moulds to thermos-form the tray component of the packaging I was able to reasonably mimic the real-world production process. This gave an idea as to how well different aspects of the design would work. One of the design details that was a result of this testing process was the 2mm lip around the rim, (see fig 58). This gives the tray more rigidity and strength.



Figure 58: Creation of moulds and thermo-foming process

Figure 69: Finalised mould (following page)





Chapter 6

Conclusion

Food as a product is experienced on multiple levels; that is, informed by all five of our senses — touch, smell, sound and sight as well as taste. Packaging is not just a means to contain and protect food, although this is an important function, it also forms the staging post to inform and instigate the complex sensorial engagements we have with a food product. In the case of most packaged foods the packaging acts as an intermediary that informs our initial perceptions and expectations of that food product. Spence states that, “Ultimately it’s the interaction between what’s in our mouth and what’s in our mind that determines what the final tasting experience is like, and how much we enjoy it. Master both food and gastrophysics [the mind’s interpretation of food] and you’ll be in a good place to impress.”(2017, p.14)

As discussed in the introduction, there has been an interest in collaboration between the College of Creative Arts and the Massey University Institute of Food Science Technology in Palmerston North. This research project is one of the responses to this call. By summarising the research project described above, the introduction addresses the important role that packaging plays in making kiwiberries a viable export fruit. This section also outlines the importance of having greater understanding around how to present this product to primary consumers in Asia. These points were reinforced through the research findings of this project.

Qualitative research methods gave me a unique perspective on the entire journey of kiwiberries from orchard to consumer. These research methods gave rich insights that informed the design process. The context review introduced and analysed fundamental considerations and challenges of developing packaging for fresh produce, as well as the sensorial interactions between packaging and consumer. Furthermore, the context review introduces unique characteristics of the Asian market that influence the way fruits such as kiwiberries are packaged, retailed and consumed. The last part of the contextual review examines two case studies of New Zealand fruit exporters that have applied packaging design to enhance the experiential value of their fruit.

Findings from primary and contextual research were used as a framework to inform and guide the design process. This began with the ideation phase which led to more in-depth sketch modelling and sensory explorations. Concepts derived from the ideation phase were developed and analysed, and industry feedback was given which affirmed the design direction. A final stage of design iterations culminated in the refinement of the final design outcome: the Kiwi-Pack packaging system.

The design outcome and research from this project has achieved the goal of offering the kiwiberry industry a creative new approach for packaging kiwiberries. It adds value to the consumer experience through sensorial and cultural consideration whilst maintaining preservation and protective functions. This project has demonstrated that bringing together the fields of design and food science technology is of value to New Zealand's agri-food sector.

The Kiwi-Pack system addresses functional performance through analysing the current packaging method and considering industry and scientific thinking around optimal packaging technologies for packing berry fruit.

Through this research a deeper look is taken at the communicative aspects of fresh fruit packaging. This goes beyond labels and brands to interrogate the semiotics of packaging design. This investigation revealed how sensorial aspects of packaging, like colour and form, as well as social and cultural values influence how fruits are perceived and experienced.

Through this research I have developed positive connections with a wide range of professionals working in fields directly or indirectly related to the kiwiberry industry. These connections gave this research input from a diverse range of perspectives, spanning cultures which encompass New Zealand, Taiwan, Singapore and Hong Kong as well as disciplines within marketing, food science technology, material science and manufacturing.

This project has opened many interesting research avenues that could be taken further, such as the nexus between online and offline food retail, as well as cross-cultural design of food products. More broadly it has introduced me to the fascinating intersections between food and design which I will continue to explore. In regard to the Kiwi-Pack system, ultimately, I would like to further engage with the kiwiberry industry and Institute of Food Science and Technology to analyse the real-world performance and application of this prototype packaging format.

Along with analysing its physical and technical performance, I believe consumer testing within selected target markets like Japan and Taiwan would have merit. This was not within the scope of this project. Such further testing will prove how the design will be received in the markets.

What was learned from this project applies not only to the New Zealand kiwiberry industry but to the wider horticulture export sector.

Reference list

- Aspelund, K. (2014). *The design process*. New York : Fairchild Books, an imprint of Bloomsbury Publishing Inc., 2015.
- Bassi, A. (2015). *Food design in Italy : product development and communication*. Milan : Electa architettura, [2015].
- Beech, G. (2017, March 13). Rokit Global Limited positioned for significant international growth. Retrieved December 15, 2017, from <http://www.freshplaza.com/article/172265/Rokit-Global-Limited-positioned-for-significant-international-growth>
- Beverland, M. (2001). Creating value through brands: the ZESPRITM kiwi fruit case. *British Food Journal*, 103(6), 383–399. <https://doi.org/10.1108/00070700110400389>
- Bez, E. (2016,). LOGISTIC AND DISTRIBUTION STRATEGIES IN THE FRESH FRUIT SUPPLY CHAIN: THE CASE OF KIWIBERRY FROM NEW ZEALAND. Retrieved January 29, 2017, from <http://edepot.wur.nl/385505>
- Bloch, P. H. (1995). Seeking the Ideal Form: Product Design and Consumer Response. *Journal of Marketing*, 59(3), 16–29. <https://doi.org/10.2307/1252116>
- Brody, A. L., Zhuang, H., & Han, J. H. (2011). *Modified atmosphere packaging for fresh-cut fruits and vegetables*. Chichester, West Sussex, UK ; Ames, Iowa : Wiley-Blackwell, 2011.
- Brunazzi, G., Parisi, S., & Pereno, A. (2014). *The importance of packaging design for the chemistry of food products*. Cham ; New York: Springer.
- Buerk, R. (2012, March 15). Japan's obsession with perfect fruit. *BBC News*. Retrieved from <http://www.bbc.com/news/world-radio-and-tv-17352173>
- Burch, D., & Lawrence, G. A. (2005). *Supermarket Own Brands, Supply Chains and the Transformation of the*

Agri-food System. *International Journal of Sociology of Agriculture and Food*, 13(1), 1–18.

- Carless, C. (2016, February 11). Fresh thinking in tomato & berry packing. Retrieved January 9, 2018, from <http://www.freshplaza.com/article/2639/Fresh-thinking-in-tomato-and-berry-packing>
- Charlebois, S. (2017, 12). How blockchain technology could transform the food industry. Retrieved January 20, 2018, from <http://theconversation.com/how-blockchain-technology-could-transform-the-food-industry-89348>
- Creswell, J. W. (2018). *Qualitative inquiry & research design : choosing among five approaches*. Los Angeles : SAGE , [2018].
- Driver, T., Saunders, C. M., Guenther, M., Dalziel, P. C., & Rutherford, P. (2015). Maximising export returns: the use of digital media and smart technology in shopping and information gathering for food and beverages in markets relevant to New Zealand. Lincoln University, AERU. Retrieved from <https://researcharchive.lincoln.ac.nz/handle/10182/6928>
- Fisk, C. L., Silver, A. M., Strik, B. C., & Zhao, Y. (2008). Postharvest quality of hardy kiwifruit (*Actinidia arguta* 'Ananasnaya') associated with packaging and storage conditions. *Postharvest Biology and Technology*, 47(3), 338–345. <https://doi.org/10.1016/j.postharvbio.2007.07.015>
- Fresh Plaza.com. (2017, March 6). Controlled atmosphere packaging for blueberries gaining popularity. Retrieved January 9, 2018, from <http://www.freshplaza.com/article/171621/Controlled-atmosphere-packaging-for-blueberries-gaining-popularity>
- Gray, D. E. (2009). *Doing research in the real world*. Los Angeles : SAGE, 2009.
- Havinga, T. (2006). Private Regulation of Food Safety by Supermarkets. *Law & Policy*, 28(4), 515–533. <https://doi.org/10.1111/j.1467-9930.2006.00237.x>
- Hongyan Yu, Ann Veeck, & Fang (Grace) Yu. (2015). Family meals and identity in urban China. *Journal of Consumer Marketing*, 32(7), 505–519. <https://doi.org/10.1108/JCM-09-2014-1146>
- Hung, K. H., Li, S. Y., Belk, R. W., Hung, K. H., & Belk, R. W. (2007). Glocal understandings: female readers' perceptions of the new woman in Chinese advertising.

- Journal of International Business Studies, 38(6), 1034–1051. <https://doi.org/10.1057/palgrave.jibs.8400303>
- New Zealand Horticultural Export Authority. (2016). Kiwifruit Trade - Information. Retrieved January 15, 2018, from <http://www.hea.co.nz/2012-05-11-03-05-28/kiwifruit-trade#>
 - Norman, D. A. (2013). *The design of everyday things*. New York, NY : Basic Books, 2013.
 - NZ Business new. (2017, December 27). \$13M Rocket apple scheme oversubscribed - 27-Dec-2017 - NZ Business news. Retrieved January 9, 2018, from <http://home.nzcity.co.nz/news/article.aspx?id=261560>
 - Pink, S. (2013). *Doing visual ethnography*. Los Angeles, California : SAGE, 2013.
 - Plant and Food Research. (2017). *Growing Futures: Horticulture Industry*. Retrieved January 15, 2018, from <https://www.plantandfood.co.nz/growingfutures/horticulture>
 - Proudfoot, I. (2016, November 10). NEWS -- NZ agri-sector challenged to find its 'missing' share of 0.25 trillion | KPMG | NZ. Retrieved January 8, 2018, from <https://home.kpmg.com/nz/en/home/media/press-releases/2016/11/agribusiness-agenda-2016-volume2-foresight-to-the-future.html>
 - Qing, P., Lobo, A., & Chongguang, L. (2012). The impact of lifestyle and ethnocentrism on consumers' purchase intentions of fresh fruit in China. *Journal of Consumer Marketing*, 29(1), 43–51. <https://doi.org/10.1108/07363761211193037>
 - Robertson, G. L. (2013). *Food packaging : principles and practice*. Boca Raton, FL : CRC Press, c2013.
 - Russell, M. (2017, May 30). Hort Connections: “Smart Packaging” is the way of the future. Retrieved June 15, 2017, from <http://www.freshplaza.com/article/176267/Hort-Connections-Smart-Packaging-is-the-way-of-the-future>
 - Saunders, C. M., McDonald, H., & Driver, T. (2011). *Enhancing value for New Zealand farmers by improving the value chain (Report)*. Lincoln University. Agricultural Economics Research Unit. Retrieved from <https://researcharchive.lincoln.ac.nz/handle/10182/4375>
 - Schifferstein, H. N. J. (2016). What design can bring to the food industry. *International Journal of Food Design*, 1(2). https://doi.org/10.1386/ijfd.1.2.103_1

- Schifferstein, H. N. J., Fenko, A., Desmet, P. M. A., Labbe, D., & Martin, N. (2013). Influence of package design on the dynamics of multisensory and emotional food experience. *Food Quality and Preference*, 27(1), 18–25. <https://doi.org/10.1016/j.foodqual.2012.06.003>
- Spence, C. (2017). *Gastrophysics: The New Science of Eating*. New York: Viking.
- Twitter, LinkedIn, & Facebook. (n.d.). The Design Process: What is the Double Diamond? Retrieved January 9, 2018, from <https://www.designcouncil.org.uk/news-opinion/design-process-what-double-diamond>
- www.asiafruitlogistica.com. (2017). ASIA FRUIT LOGISTICA - ASIA FRUIT LOGISTICA. Retrieved January 13, 2018, from <http://www.asiafruitlogistica.com/About/ASIAFRUITLOGISTICA/>
- Yuri Seo, Angela Gracia B. Cruz, & Kim-Shyan Fam. (2015). Food consumption and marketing: turning toward Asia. *Journal of Consumer Marketing*, 32(7), 501–504. <https://doi.org/10.1108/JCM-07-2015-1498>

Appendix 1: Ethics Approval

1/21/2018

Gmail - Human Ethics Notification - 4000017181



Justin Hughes [REDACTED]

Human Ethics Notification - 4000017181

1 message

humanethics@massey.ac.nz <humanethics@massey.ac.nz> Thu, Feb 2, 2017 at 5:19 PM
To: A.Lindsay@massey.ac.nz, Justin.hughes.3@uni.massey.ac.nz, M.N.Siljee@massey.ac.nz
Cc: M.E.Thomas@massey.ac.nz

HoU Review Group

Ethics Notification Number: 4000017181
Title: ENHANCING THE VALUE OF KIWI-BERRIES THROUGH PACKAGING DESIGN:

Thank you for your notification which you have assessed as Low Risk.

Your project has been recorded in our system which is reported in the Annual Report of the Massey University Human Ethics Committee.

The low risk notification for this project is valid for a maximum of three years.

If situations subsequently occur which cause you to reconsider your ethical analysis, please log on to <http://rims.massey.ac.nz> and register the changes in order that they be assessed as safe to proceed.

Please note that travel undertaken by students must be approved by the supervisor and the relevant Pro Vice-Chancellor and be in accordance with the Policy and Procedures for Course-Related Student Travel Overseas. In addition, the supervisor must advise the University's Insurance Officer.

A reminder to include the following statement on all public documents:

"This project has been evaluated by peer review and judged to be low risk. Consequently it has not been reviewed by one of the University's Human Ethics Committees. The researcher(s) named in this document are responsible for the ethical conduct of this research.

If you have any concerns about the conduct of this research that you want to raise with someone other than the researcher(s), please contact Dr Brian Finch, Director (Research Ethics), email humanethics@massey.ac.nz. "

Please note that if a sponsoring organisation, funding authority or a journal in which you wish to publish require evidence of committee approval (with an approval number), you will have to complete the application form again answering yes to the publication question to provide more information to go before one of the University's Human Ethics Committees. You should also note that such an approval can only be provided prior to the commencement of the research.

You are reminded that staff researchers and supervisors are fully responsible for ensuring that the information in the low risk notification has met the requirements and guidelines for submission of a low risk notification.

If you wish to print an official copy of this letter, please login to the RIMS system, and under the Reporting section, View Reports you will find a link to run the LR Report.

Yours sincerely

Dr Brian Finch
Chair, Human Ethics Chairs' Committee and
Director (Research Ethics)

https://mail.google.com/mail/u/0/?ui=2&ik=472cf25081&jsver=NW_2aT3fA0.en.&view=pt&q=ethics%20approval%20&search=query&th=159fd0ca... 1/1

Appendix 2A: Participant consent forms

PARTICIPANT CONSENT FORM

Name: Chris Dunn

email: wikmanagement@vta.co.nz

City: _____

The future of packaging design for the Kiwi berry industry.
by Justin Hughes

This consent form will be held for a period of five (5) years

I have had the details of the *The future of packaging design for the Kiwi berry industry*: project explained to me. My questions have been answered to my satisfaction, and I understand that I may ask further questions at any time.

Please circle one option for each clause...

- I agree/do not agree to the documentation of my participation in this research.
- I agree/do not agree that my participation in this research can be attributed to me.
- I agree/do not agree to the audio recording of my participation in this research. (N/A)
- I agree/do not agree to the photography of my participation in this research. (N/A)
- I wish/do not wish to have audio tapes or photographs sent to me. (N/A)
- I would like/would not like a copy of this document
- I am willing/not willing to be contacted

I agree to participate in *The future of packaging design for the Kiwi berry industry* under the conditions I have outlined above.

Signature:  Date: 08/03/2017

Full Name - printed
Chris Dunn

We take your privacy seriously. Your contact information will never be used for any other purpose other than to contact you about your participation in this design research.

Appendix 2B: Participant consent forms



PARTICIPANT CONSENT FORM

Name: Lee Yen Yen

email: Yenyen.lee@singaporetech.edu.sg

City: Singapore

The future of packaging design for the Kiwi berry industry.
by Justin Hughes

This consent form will be held for a period of five (5) years

I have had the details of the *The future of packaging design for the Kiwi berry industry*: project explained to me. My questions have been answered to my satisfaction, and I understand that I may ask further questions at any time.

Please circle one option for each clause...

- I agree/do not agree to the documentation of my participation in this research.
- I agree/do not agree that my participation in this research can be attributed to me.
- I agree/do not agree to the audio recording of my participation in this research. (N/A)
- I agree/do not agree to the photography of my participation in this research. (N/A)
- I wish/do not wish to have audio tapes or photographs sent to me. (N/A)
- I would like/would not like a copy of this document
- I am willing/not willing to be contacted

I agree to participate in *The future of packaging design for the Kiwi berry industry* under the conditions I have outlined above.

Signature:

Full Name - printed

Date:

31/3/17

We take your privacy seriously. Your contact information will never be used for any other purpose other than to contact you about your participation in this design research.

Appendix 2C: Participant consent forms



PARTICIPANT CONSENT FORM

Name: Kaiyang Lim
 email: Kaiyang.lim@Singaporetech.edu.sg
 City: Singapore

The future of packaging design for the Kiwi berry industry.
 by Justin Hughes

This consent form will be held for a period of five (5) years

I have had the details of the *The future of packaging design for the Kiwi berry industry*: project explained to me. My questions have been answered to my satisfaction, and I understand that I may ask further questions at any time.

Please circle one option for each clause...

- I agree/do not agree to the documentation of my participation in this research.
- I agree/do not agree that my participation in this research can be attributed to me.
- I agree/do not agree to the audio recording of my participation in this research. (N/A)
- I agree/do not agree to the photography of my participation in this research. (N/A)
- I wish/do not wish to have audio tapes or photographs sent to me. (N/A)
- I would like/would not like a copy of this document
- I am willing/not willing to be contacted

I agree to participate in *The future of packaging design for the Kiwi berry industry* under the conditions I have outlined above.

Signature: [Handwritten Signature] Date: 31/03/17

Full Name - printed Kaiyang Lim

We take your privacy seriously. Your contact information will never be used for any other purpose other than to contact you about your participation in this design research.

Appendix 2E: Participant consent forms



PARTICIPANT CONSENT FORM

Name: SHERMAINE TAN

email: shernaine@tianheng.com.sg

City: SINGAPORE

The future of packaging design for the Kiwi berry industry.
by Justin Hughes

This consent form will be held for a period of five (5) years

I have had the details of the *The future of packaging design for the Kiwi berry industry*: project explained to me. My questions have been answered to my satisfaction, and I understand that I may ask further questions at any time.

Please circle one option for each clause...

- I agree/~~do not agree~~ to the documentation of my participation in this research.
- I agree/~~do not agree~~ that my participation in this research can be attributed to me.
- I agree/~~do not agree~~ to the audio recording of my participation in this research. (N/A)
- I agree/~~do not agree~~ to the photography of my participation in this research. (N/A)
- I wish/~~do not wish~~ to have audio tapes or photographs sent to me. (N/A)
- I would like/~~would not like~~ a copy of this document
- I am willing/~~not willing~~ to be contacted

I agree to participate in *The future of packaging design for the Kiwi berry industry* under the conditions I have outlined above.

Signature: [Handwritten Signature] Date: 31 MAR 2017

TAN YA YIN SHERMAINE.
Full Name - printed

We take your privacy seriously. Your contact information will never be used for any other purpose other than to contact you about your participation in this design research.

Appendix 2F: Participant consent forms



UNIVERSITY OF NEW ZEALAND

PARTICIPANT CONSENT FORM

Name: Lou Sherman
 email: lou.sherman@scionresearch.com
 City: Rotoma

The future of packaging design for the Kiwi berry industry.
 by Justin Hughes

This consent form will be held for a period of five (5) years

I have had the details of the *The future of packaging design for the Kiwi berry industry*: project explained to me. My questions have been answered to my satisfaction, and I understand that I may ask further questions at any time.

Please circle one option for each clause...

- I agree/do not agree to the documentation of my participation in this research.
- I agree/do not agree that my participation in this research can be attributed to me.
- I agree/do not agree to the audio recording of my participation in this research. (N/A)
- I agree/do not agree to the photography of my participation in this research. (N/A)
- I wish/do not wish to have audio tapes or photographs sent to me. (N/A)
- I would like/would not like a copy of this document
- I am willing/not willing to be contacted

I agree to participate in *The future of packaging design for the Kiwi berry industry* under the conditions I have outlined above.

Signature: _____ Date: 26/06/17

Lou Sherman

Full Name - printed

Lou Sherman

We take your privacy seriously. Your contact information will never be used for any other purpose other than to contact you about your participation in this design research.

Appendix 2G: Participant consent forms



PARTICIPANT CONSENT FORM

Name: Christophe Collet

email: christophe.collet@scionresearch.com

City: Rotorua

The future of packaging design for the Kiwi berry industry.
by Justin Hughes

This consent form will be held for a period of five (5) years

I have had the details of the *The future of packaging design for the Kiwi berry industry*: project explained to me. My questions have been answered to my satisfaction, and I understand that I may ask further questions at any time.

Please circle one option for each clause...

- I agree/~~do not agree~~ to the documentation of my participation in this research.
- I agree/~~do not agree~~ that my participation in this research can be attributed to me.
- ~~• I agree/~~do not agree~~ to the audio recording of my participation in this research. (N/A)~~
- ~~• I agree/~~do not agree~~ to the photography of my participation in this research. (N/A)~~
- I wish/~~do not wish~~ to have audio tapes or photographs sent to me. (N/A)
- I would like/~~would not like~~ a copy of this document
- I am willing/~~not willing~~ to be contacted

I agree to participate in *The future of packaging design for the Kiwi berry industry* under the conditions I have outlined above.

Signature:

CCollet

Date: *26 June 2017*

Full Name - printed

Christophe Collet

We take your privacy seriously. Your contact information will never be used for any other purpose other than to contact you about your participation in this design research.

Appendix 2H: Participant consent forms



PARTICIPANT CONSENT FORM

Name: Kate Parker
 email: Kate.parker@scionresearch.com
 City: Rotorua

The future of packaging design for the Kiwi berry industry.
 by Justin Hughes

This consent form will be held for a period of five (5) years

I have had the details of the *The future of packaging design for the Kiwi berry industry*: project explained to me. My questions have been answered to my satisfaction, and I understand that I may ask further questions at any time.

Please circle one option for each clause...

- I agree/~~do not agree~~ to the documentation of my participation in this research.
- I agree/~~do not agree~~ that my participation in this research can be attributed to me.
- I agree/~~do not agree~~ to the audio recording of my participation in this research. (N/A)
- I agree/~~do not agree~~ to the photography of my participation in this research. (N/A)
- I wish/~~do not wish~~ to have audio tapes or photographs sent to me. (N/A)
- I would like/~~would not like~~ a copy of this document
- I am willing/~~not willing~~ to be contacted

I agree to participate in *The future of packaging design for the Kiwi berry industry* under the conditions I have outlined above.

Signature: [Handwritten Signature] Date: 26/6/17
 Full Name - printed
Kate Parker.

please can we view any final reports/presentations (using our materials) prior to release.

We take your privacy seriously. Your contact information will never be used for any other purpose other than to contact you about your participation in this design research.

Appendix 2I: Participant consent forms

PARTICIPANT CONSENT FORM

Name: Sarah Baylis
 email: Sarah@packedge.co.nz
 City: Wellington

The future of packaging design for the Kiwi berry industry.
 by Justin Hughes

This consent form will be held for a period of five (5) years

I have had the details of the *The future of packaging design for the Kiwi berry industry*: project explained to me. My questions have been answered to my satisfaction, and I understand that I may ask further questions at any time.

Please circle one option for each clause...

- I **agree**/do not agree to the documentation of my participation in this research.
- I **agree**/do not agree that my participation in this research can be attributed to me.
- I **agree**/do not agree to the audio recording of my participation in this research. (N/A)
- I **agree**/do not agree to the photography of my participation in this research. (N/A)
- I **wish**/do not wish to have audio tapes or photographs sent to me. (N/A)
- I **would like**/~~would not like~~ a copy of this document
- I am **willing**/~~not willing~~ to be contacted

I agree to participate in *The future of packaging design for the Kiwi berry industry* under the conditions I have outlined above.

Signature:  Date: 14/7/17

Full Name - printed

Sarah Baylis

We take your privacy seriously. Your contact information will never be used for any other purpose other than to contact you about your participation in this design research.

Appendix 2J: Participant consent forms



PARTICIPANT CONSENT FORM

Name: Emi Chen

email: emi.chen@Zespri.com

City: Taipei (Taiwan)

The future of packaging design for the Kiwi berry industry.
by Justin Hughes

This consent form will be held for a period of five (5) years

I have had the details of the *The future of packaging design for the Kiwi berry industry*: project explained to me. My questions have been answered to my satisfaction, and I understand that I may ask further questions at any time.

Please circle one option for each clause...

- ~~agree~~/do not agree to the documentation of my participation in this research.
- ~~agree~~/do not agree that my participation in this research can be attributed to me.
- ~~agree~~/do not agree to the audio recording of my participation in this research. (N/A)
- ~~agree~~/do not agree to the photography of my participation in this research. (N/A)
- ~~wish~~/do not wish to have audio tapes or photographs sent to me. (N/A)
- ~~would like~~/would not like a copy of this document
- I am ~~willing~~/not willing to be contacted

I agree to participate in *The future of packaging design for the Kiwi berry industry* under the conditions I have outlined above.

Signature: Emi Chen Date: 6/2. 2017.

Full Name - printed
Emi Chen

We take your privacy seriously. Your contact information will never be used for any other purpose other than to contact you about your participation in this design research.

Appendix 2K: Participant consent forms

PARTICIPANT CONSENT FORM

Name: REECE VAN DEN BERG
 email: reece@nzcherrycorp.com
 City: WLG

The future of packaging design for the Kiwi berry industry.
 by Justin Hughes

This consent form will be held for a period of five (5) years

I have had the details of the *The future of packaging design for the Kiwi berry industry*: project explained to me. My questions have been answered to my satisfaction, and I understand that I may ask further questions at any time.

Please circle one option for each clause...

- I agree/~~do not agree~~ to the documentation of my participation in this research.
- I agree/~~do not agree~~ that my participation in this research can be attributed to me.
- I agree/~~do not agree~~ to the audio recording of my participation in this research. (N/A)
- I agree/~~do not agree~~ to the photography of my participation in this research. (N/A)
- I wish/~~do not wish~~ to have audio tapes or photographs sent to me. (N/A)
- I would like/~~would not like~~ a copy of this document
- I am willing/~~not willing~~ to be contacted

I agree to participate in *The future of packaging design for the Kiwi berry industry* under the conditions I have outlined above.

Signature: RL Date: 6/3/17

Full Name - printed
REECE VAN DEN BERG

We take your privacy seriously. Your contact information will never be used for any other purpose other than to contact you about your participation in this design research.

Appendix 3 A1: Consumer survey



Berry Fruit Questionnaire

Do you eat berry fruit e.g., blueberries, raspberries, cherries, Etc? Yes / No

How often do you eat them?

not often 2 months

What do you like or dislike about berry fruit?

Tangy / sweet

What you look for when buying berry fruit?

- pick the nicest box
-
-
-

When and how do you eat berry fruit e.g., for breakfast, as a snack or in a dessert?

dessert

How much berry fruit would you buy in one go?

1 p 1 packet

Does how the Berries are packaged matter to you of influence you chose, if so how?

Yes / nice hot packaging

Appendix 3 A2: Consumer survey

Kiwi Berries

Have you seen Kiwi berries in the supermarket Yes No

Have you ever eaten Kiwi berries Yes No

(If they have not heard of kiwi berries show them a photo to get their impressions)

What did you think of them?

look sour; green = sour

If you haven't had kiwi berries before, are they a fruit that you would be interested in trying ? Why or why not ?

yes, just to see what they are like

Basic participant information:

Please circle the relevant brackets

Age: are you: (18 to 30) (30 to 40) (40 to 50) (50 to 60) (60+)

Gender: (Male) (Female)

*packaging
Should not be green*

I agree that the information I have provided in this questionnaire can be use as part research towards the Master's project - The future of packaging design for the Kiwi berry industry - undertaken by JUSTIN HUGHES.

Signature: *[Handwritten Signature]*

Date: *3/4/17*

Full name - printed: *WONG LI PINK*

Email - Optional:

We take your privacy seriously. Your contact information will never be used for any other purpose other than to contact you about your participation in this design research.

Appendix 3 B1: Consumer survey



Berry Fruit Questionnaire

Strawberries
blueberries

Do you eat berry fruit e.g., blueberries, raspberries, cherries, Etc.? Yes / No

How often do you eat them?

not often to expensive

What do you like or dislike about berry fruit?

price's

What you look for when buying berry fruit?

Fresh and Sweet.
Value for quality/growth

When and how do you eat berry fruit e.g., for breakfast, as a snack or in a dessert?

L1
L2 = dinner

How much berry fruit would you buy in one go?

1 small pack

Does how the Berries are packaged matter to you of influence you chose, if so how?

yes, transparency

Meglasia

Appendix 3 B2: Consumer survey

Kiwi Berries

do like like
kiwi gold
green =
to sent.

Have you seen Kiwi berries in the supermarket Yes No

Have you ever eaten Kiwi berries Yes / No

(If they have not heard of kiwi berries show them a photo to get their impressions)

What did you think of them?

If you haven't had kiwi berries before, are they a fruit that you would be interested in trying ? Why or why not ?

with out see what they look like
inside its hard to know , but yes.
Having seen the picture.

Basic participant information:

Please circle the relevant brackets

Age: are you: (18 to 30) (30 to 40) (40 to 50) (50 to 60) (60+)

Gender: (Male) (Female)

I agree that the information I have provided in this questionnaire can be use as part research towards the Master's project - The future of packaging design for the Kiwi berry industry - undertaken by JUSTIN HUGHES.

Signature: *Murugesu*

Date: 3/4/17

Full name - printed: *Murugesu & Pri's*

Email - Optional:

We take your privacy seriously. Your contact information will never be used for any other purpose other than to contact you about your participation in this design research.

two ladies from malaysia.

Appendix 3 C1: Consumer survey



Berry Fruit Questionnaire

Do you eat berry fruit e.g., blueberries, raspberries, cherries, Etc. Yes / No

How often do you eat them? *Sometimes*

What do you like or dislike about berry fruit?
Healthy

What you look for when buying berry fruit?
- *Price*
- *Frozen for younger*

When and how do you eat berry fruit e.g., for breakfast, as a snack or in a dessert?
dessert / sometimes Breakfast

How much berry fruit would you buy in one go?
3 to 5 are a week

Does how the Berries are packaged matter to you of influence you chose, if so how?
not really

Appendix 3 C2: Consumer survey

Kiwi Berries

Have you seen Kiwi berries in the supermarket Yes / No

Have you ever eaten Kiwi berries Yes / No

(If they have not heard of kiwi berries show them a photo to get their impressions)

What did you think of them?

If you haven't had kiwi berries before, are they a fruit that you would be interested in trying ? Why or why not ?

Yes, they look healthy/curiosity

Basic participant information:

Please circle the relevant brackets

Age: are you: (18 to 30) (30 to 40) (40 to 50) (50 to 60) (60+)

Gender: (Male) (Female)

I agree that the information I have provided in this questionnaire can be use as part research towards the Master's project - The future of packaging design for the Kiwi berry industry - undertaken by JUSTIN HUGHES.

Signature: *[Handwritten Signature]*

Date:

Full name - printed:

Email - Optional:

We take your privacy seriously. Your contact information will never be used for any other purpose other than to contact you about your participation in this design research.

Yang Mum,

Appendix 3 D1: Consumer survey

Kiwi Berries

gold = sweet
they advertise Vita C
like Kiwi fruit alot

Have you seen Kiwi berries in the supermarket Yes No

Have you ever eaten Kiwi berries Yes No

(If they have not heard of kiwi berries show them a photo to get their impressions)

What did you think of them?

If you haven't had kiwi berries before, are they a fruit that you would be interested in trying ? Why or why not ?

Yes they would be intese, becausse it is
~~new~~ new.

Basic participant information:

Please circle the relevant brackets

Age: are you: (18 to 30) (30 to 40) (40 to 50) (50 to 60) (60+)

Gender: (Male) (Female) couple

I agree that the information I have provided in this questionnaire can be use as part research towards the Master's project - The future of packaging design for the Kiwi berry industry - undertaken by JUSTIN HUGHES.

Signature: *Jane*
Full name - printed: Jane Tan

Date: 5/4/17

Email - Optional:

We take your privacy seriously. Your contact information will never be used for any other purpose other than to contact you about your participation in this design research.

Shop at FairPrice

Appendix 3 D2: Consumer survey



Berry Fruit Questionnaire

mostly 'hoan

Do you eat berry fruit e.g., blueberries, raspberries, cherries, Etc. Yes / No

How often do you eat them?

When in season / ever of year

What do you like or dislike about berry fruit?

1 big punter.

What you look for when buying berry fruit?

Brightness, ripeness

When and how do you eat berry fruit e.g., for breakfast, as a snack or in a dessert?

dessert with IC / yogurt

How much berry fruit would you buy in one go?

1 punnet, 2 if on special

Does how the Berries are packaged matter to you of influence you chose, if so how?

not

Appendix 3 E1: Consumer survey



Berry Fruit Questionnaire

Do you eat berry fruit e.g., blueberries, raspberries, cherries, Etc. Yes / No

Starberr.

Raspberries

How often do you eat them?

1/2 berry per day / summer season

What do you like or dislike about berry fruit?

Soft / sweet texture

What you look for when buying berry fruit?

sweet one / ask Eric Reppes for recommendation

When and how do you eat berry fruit e.g., for breakfast, as a snack or in a dessert?

with yogurt / afternoon

How much berry fruit would you buy in one go?

Does how the Berries are packaged matter to you of influence you chose, if so how?

*looks online, for best fruit
pp ptt. app.*

Appendix 3 E2: Consumer survey

Kiwi Berries

Have you seen Kiwi berries in the supermarket Yes / No

Have you ever eaten Kiwi berries Yes / No

perfect, good

(If they have not heard of kiwi berries show them a photo to get their impressions)

What did you think of them?

If you haven't had kiwi berries before, are they a fruit that you would be interested in trying ? Why or why not ?

yes packaging dose not disclose taste so perfect not

Basic participant information:

Please circle the relevant brackets

Age: are you: (18 to 30) (30 to 40) (40 to 50) (50 to 60) (60+)

Gender: (Male) (Female)

I agree that the information I have provided in this questionnaire can be use as part research towards the Master's project - The future of packaging design for the Kiwi berry industry - undertaken by JUSTIN HUGHES.

Signature: *廖乙璇*

Date: *4.03*

Full name - printed:

Email - Optional:

We take your privacy seriously. Your contact information will never be used for any other purpose other than to contact you about your participation in this design research.

廖乙璇

Appendix 3 F1: Consumer survey

軟棗奇異果 訪問卷

你在超市裡有見過 軟棗奇異果嗎? 見過 / 沒見過

NO

你有吃過 軟棗奇異果嗎? 吃過 / 沒吃過

NO

如果你沒有見過 軟棗奇異果，這是它的圖片，你對軟棗奇異果有什麼想法?

like 軟棗 / area nut

如果你沒有吃過軟棗奇異果，那麼你會有興趣品嚐下? 為甚麼有興趣? 為甚麼沒有興趣?

Sour / lead don't like.

受訪人資料: (請用筆圈出相關的選項)

本人的年齡組: 18-30週歲 30-40週歲 40-50週歲 50-60週歲 60週歲以上

性別: 男 / 女

本人同意放問卷所回答問題可以被用作項目研究用途，用於Justin Hughes的碩士研究項目：軟棗奇異果的未來包裝。

簽名: 

日期:

全名 (正楷):

郵件 (可選填):

機密性: 項目主持非常重視機密性，你的聯繫方式將永遠不會用於任何其他與本次研究項目無關的用途和目的。

Appendix 3 F2: Consumer survey



莓果訪問卷

你吃藍莓，覆盆子，櫻桃等莓果嗎？ 吃 / 不吃

你吃莓果的頻率？ 10/year

你對莓果是： 喜歡 / 不喜歡

你在購買莓果的時候注重什麼呢？

- fresh

-

-

-

你喜歡怎麼吃莓果呢？（ 直接吃 / 還是混入早餐，或者當零食甜點呢？）

你一次會買多少莓果呢？ 一盒 + one pack

莓果的包裝盒對你的購買選擇上有什麼的影響嗎？

yes

Appendix 3 G1: Consumer survey



莓果 訪問卷

你吃藍莓，覆盆子，櫻桃等莓果嗎？ 吃 / 不吃

你吃莓果的頻率？ 2-3.

你對莓果是： 喜歡 / 不喜歡

你在購買莓果的時候注重什麼呢？

- quality.
- 產地. x Original location of produce
-
-

你喜歡怎麼吃莓果呢？ 直接吃^x，還是混入早餐，或者當零食甜點呢？

你一次會買多少莓果呢？ - 一盒 x one pack

莓果的包裝盒對你的購買選擇上有什麼的影響嗎？

yes.

Appendix 3 G2: Consumer survey

軟棗奇異果 訪問卷

你在超市裡有見過 軟棗奇異果嗎? 見過 / 沒見過

你有吃過 軟棗奇異果嗎? 吃過 / 沒吃過

如果你沒有見過 軟棗奇異果，這是它的圖片，你對軟棗奇異果有什麼想法?

*冇得. oliver. looks like olives
it's really convenient to eat.*

如果你沒有吃過軟棗奇異果，那麼你會有興趣品嚐下? 為甚麼有興趣? 為甚麼沒有興趣?

受訪人資料: (請用筆圈出相關的選項)

本人的年齡組: 18-30週歲 30-40週歲 40-50週歲 50-60週歲 60週歲以上

性別: 男 / 女
male female

本人同意訪問卷所回答問題可以被用作項目研究用途，用於Justin Hughes的碩士研究項目：軟棗奇異果的未來包裝。

簽名: *ng sir*

日期: *8/4*

全名 (正楷):

郵件 (可選填):

機密性: 項目主持非常重視機密性，你的聯繫方式將永遠不會用於任何其他與本次研究項目無關的用途和目的。

ng

Appendix 3 H1: Consumer survey

軟棗奇異果 訪問卷

你在超市裡有見過 軟棗奇異果嗎? 見過 / 沒見過

你有吃過 軟棗奇異果嗎? 吃過 / 沒吃過

如果你沒有見過 軟棗奇異果，這是它的圖片，你對軟棗奇異果有什麼想法?

Sour,

如果你沒有吃過軟棗奇異果，那麼你會有興趣品嚐下? 為甚麼有興趣? 為甚麼沒有興趣?

x 不興趣 have no interest

受訪人資料: (請用筆圈出相關的選項)

本人的年齡組: 18-30週歲 30-40週歲 40-50週歲 50-60週歲 60週歲以上

性別: 男 / 女

本人同意訪問卷所回答問題可以被用作項目研究用途，用於Justin Hughes的碩士研究項目：軟棗奇異果的未來包裝。

簽名:



日期:

全名 (正楷):

郵件 (可選填):

機密性: 項目主持非常重視機密性，你的聯繫方式將永遠不會用於任何其他與本次研究項目無關的用途和目的。

Appendix 3 H2: Consumer survey



莓果 訪問卷

你吃藍莓，覆盆子，櫻桃等莓果嗎？ 吃 不吃

你吃莓果的頻率？ 10 / 5 times

你對莓果是 喜歡 不喜歡

你在購買莓果的時候注重什麼呢？

- fresh.
- organic
-
-

你喜歡怎麼吃莓果呢？ 直接吃，還是混入早餐，或者當零食甜點呢？

你一次會買多少莓果呢？

莓果的包裝盒對你的購買選擇上有什麼的影響嗎？

yes.

Appendix 3 H1: Consumer survey



莓果 訪問卷

你吃藍莓，覆盆子，櫻桃等莓果嗎？ 吃 不吃

你吃莓果的頻率？ 1-2 / year

你對莓果是： 喜歡 ^{OK} / 不喜歡

你在購買莓果的時候注重什麼呢？

-
-
-
-

你喜歡怎麼吃莓果呢？（直接吃，還是混入早餐，或者當零食甜點呢？）

你一次會買多少莓果呢？

莓果的包裝盒對你的購買選擇上有什麼的影響嗎？

x 價格 price

Appendix 3 H2: Consumer survey

軟棗奇異果 訪問卷

你在超市裡有見過 軟棗奇異果嗎? 見過 / 沒見過

你有吃過 軟棗奇異果嗎? 吃過 / 沒吃過

如果你沒有見過 軟棗奇異果，這是它的圖片，你對軟棗奇異果有什麼想法?

Some fruit kiwi

如果你沒有吃過軟棗奇異果，那麼你會有興趣品嚐下? 為甚麼有興趣? 為甚麼沒有興趣?

OK

受訪人資料: (請用筆圈出相關的選項)

本人的年齡組: 18-30週歲 30-40週歲 40-50週歲 50-60週歲 60週歲以上

性別: 男 女

本人同意放問卷所回答問題可以被用作項目研究用途，用於Justin Hughes的碩士研究項目：軟棗奇異果的未來包裝。

簽名: 謝志強

日期:

全名 (正楷):

郵件 (可選填):

機密性: 項目主持非常重視機密性，你的聯繫方式將永遠不會用於任何其他與本次研究項目無關的用途和目的。

Appendix 3 I1: Consumer survey



莓果 訪問卷

你吃藍莓，覆盆子，櫻桃等莓果嗎？ 吃 / 不吃

你吃莓果的頻率？ 1-3 個月

你對莓果是： 喜歡 / 不喜歡

你在購買莓果的時候注重什麼呢？

- color
- fresh
-
-

你喜歡怎麼吃莓果呢？ (直接吃) 還是混入早餐，或者當零食甜點呢？

你一次會買多少莓果呢？ 1 盒 + one pack

莓果的包裝盒對你的購買選擇上有什麼的影響嗎？

yes

Appendix 3 I2: Consumer survey

軟棗奇異果 訪問卷

你在超市裡有見過 軟棗奇異果嗎? 見過 / 沒見過

你有吃過 軟棗奇異果嗎? 吃過 / 沒吃過

如果你沒有見過 軟棗奇異果，這是它的圖片，你對軟棗奇異果有什麼想法?

小荔枝, 外皮不可吃. + ^{can't eat} ~~the~~ the peel ~~is not~~

如果你沒有吃過軟棗奇異果，那麼你會有興趣品嚐下? 為甚麼有興趣? 為甚麼沒有興趣?

yes. first see. want to try
Tayler-like knife, 方便 More convenient

受訪人資料: (請用筆圈出相關的選項)

本人的年齡組: 18-30週歲 30-40週歲 40-50週歲 50-60週歲 60週歲以上

性別: 男 / 女

本人同意訪問卷所回答問題可以被用作項目研究用途，用於Justin Hughes的碩士研究項目：軟棗奇異果的未來包裝。

簽名: 蔡可筠

日期: 8/4

全名 (正楷):

郵件 (可選填):

機密性: 項目主持非常重視機密性，你的聯繫方式將永遠不會用於任何其他與本次研究項目無關的用途和目的。

Appendix 3 J1: Consumer survey



莓果訪問卷

你吃藍莓，覆盆子，櫻桃等莓果嗎？ 吃 / 不吃

你吃莓果的頻率？ 1 / year

你對莓果是： 喜歡 不喜歡

你在購買莓果的時候注重什麼呢？

- fresh.
- sour?
- 味道?
-

你喜歡怎麼吃莓果呢？（直接吃，還是混入早餐，或者當零食甜點呢？）

cherry 酸奶 + yogurt

你一次會買多少莓果呢？

1 盒 + one pack

莓果的包裝盒對你的購買選擇上有什麼的影響嗎？

no + yes

Appendix 3 J2: Consumer survey

軟棗奇異果 訪問卷

你在超市裡有見過 軟棗奇異果嗎? 見過 / 沒見過

你有吃過 軟棗奇異果嗎? 吃過 / 沒吃過

如果你沒有見過 軟棗奇異果, 這是它的圖片, 你對軟棗奇異果有什麼想法?

+ 像枱, very sour, ~~酸~~ + areca nut
orange/madaria.

如果你沒有吃過軟棗奇異果, 那麼你會有興趣品嚐下? 為甚麼有興趣? 為甚麼沒有興趣?

the peel is bitter
皮太苦
驚喜,
surprise

sour,
吃酸, taste bitter
look no like 枱
like spicy fruit

受訪人資料: (請用筆圈出相關的選項)

本人的年齡組: 18-30週歲 30-40週歲 40-50週歲 50-60週歲 60週歲以上

性別: 男 / 女

本人同意放問卷所回答問題可以被用作項目研究用途, 用於Justin Hughes的碩士研究項目: 軟棗奇異果的未來包裝。

簽名: 

日期:

全名 (正楷):

郵件 (可選填):

機密性: 項目主持非常重視機密性, 你的聯繫方式將永遠不會用於任何其他與本次研究項目無關的用途和目的。

Appendix 3 K1: Consumer survey



莓果訪問卷

你吃藍莓，覆盆子，櫻桃等莓果嗎？ 吃 / 不吃

你吃莓果的頻率？ 3/year

你對莓果是： 喜歡 / 不喜歡

你在購買莓果的時候注重什麼呢？

- fresh?
- size?
- color → red → sweet
-

你喜歡怎麼吃莓果呢？ 直接吃，還是混入早餐，或者當零食甜點呢？

你一次會買多少莓果呢？ Big Box

莓果的包裝盒對你的購買選擇上有什麼的影響嗎？

a little bit,
quantity first

Appendix 3 K2: Consumer survey

軟棗奇異果 訪問卷

你在超市裡有見過 軟棗奇異果嗎? 見過 / 沒見過

你有吃過 軟棗奇異果嗎? 吃過 / 沒吃過

如果你沒有見過 軟棗奇異果，這是它的圖片，你對軟棗奇異果有什麼想法?

*interesting, sour,
looks sour, but would still try it*

如果你沒有吃過軟棗奇異果，那麼你會有興趣品嚐下? 為甚麼有興趣? 為甚麼沒有興趣?

Yes, diftere with normal kiwifruit!

*interesting purchaser atleast check out
→ will get them to search online
to find out more about it.*

受訪人資料: (請用筆圈出相關的選項)

本人的年齡組: 18-30週歲 30-40週歲 40-50週歲 50-60週歲 60週歲以上

性別: 男 女

本人同意訪問卷所回答問題可以被用作項目研究用途，用於Justin Hughes的碩士研究項目：軟棗奇異果的未來包裝。

簽名: *黃月珍*

日期: *8/4/2017*

全名 (正楷):

郵件 (可選填):

機密性: 項目主持非常重視機密性，你的聯繫方式將永遠不會用於任何其他與本次研究項目無關的用途和目的。

Jiu

