

*My design identity...*  
*My future...*

**Workbook 1 of 2**

Workbook presented in partial fulfilment of the requirements for the degree of Master of Design at Massey University, College of Creative Arts, Wellington, New Zealand.

2010 Master of Design candidate: Jason Klenner  
Supervisors: Tony Parker and Julieanna Preston



## **Abstract**

### **Title: My design identity... My future...**

My research project involves the creation of a personal design identity in order to reposition myself within the design industry at a time when the existence of New Zealand designers who work within the mass design services market is being threatened by New Zealand based manufacturing and industry moving offshore.

The design-led research has involved the observation and analysis of designers that are positioned within the high profile and high value area of the design industry including Ron Arad, Ross Lovegrove, Marc Newson and David Trubridge in order to gain insights and inspiration for developing my own personal identity. On the basis of the information gained a process of repeated experimentation and reflection in the field of design art was used to establish the foundation for my personal identity.

Symbolic of this personal design identity is a curiosity for experimentation with material and structure to create everyday objects that are not devoid of function, but not serious either.

The goal of this identity is to make users smile and to increase sentimental attachment and desirability towards these objects by offering experiences that can be described as surprising, memorable, enjoyable, light-hearted and even exhilarating when compared with utilitarian, mass market equivalents.

An example of this is a chair called 'Sprung' that integrates elastic cord with a 2-dimensional plastic sheet that flexes into a 3-dimensional springy form when sat in. This transformation is unexpected and the bounce experience fun, challenging how we view materials and structures and how chairs are perceived and used.

This research has personal significance for my future career as the personal identity developed combined with my renewed enthusiasm for design can be applied to ongoing design art objects, allowing me to establish a track record in this field and move away from the mass design services market.

# RESEARCH INTERVIEW SUMMARY:

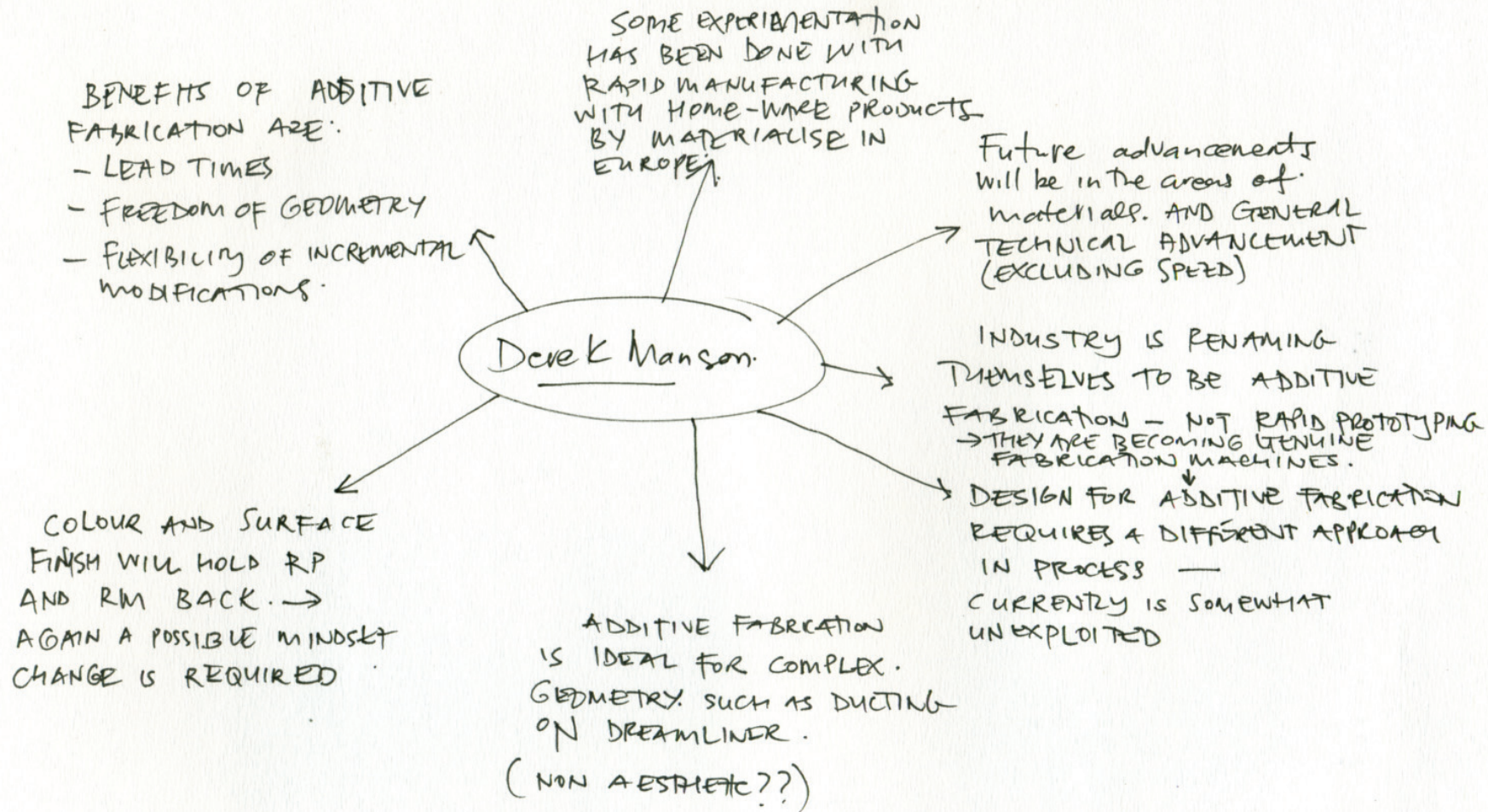

NOTE: ADDITIVE FABRICATION HAS A LONG WAY TO COME BEFORE A QUALITY PRODUCT. SURFACE FINISH CAN BE ACHIEVED. TO INCLUDE THIS WITHIN A PRODUCT AS A PROCESS A 2ND FINISH WILL BE REQUIRED (PAINT/LAMINATION ETC.) GIVEN THIS - REMOVAL FABRICATION (CNC CUTTING/LASER ETC) MAY BE MORE APPLICABLE.

## RESEARCH INTERVIEW SUMMARY:

IF APPLICABLE - VENUES LIKE OBJECTSPACE AND MASTERWORKS SUPPORT 3D/CRAFT/DESIGN AND CAN BE APPROACHED FOR POTENTIAL EXHIBITIONS.

OBJECT MAGAZINE FEATURES NEW ZEALAND EXHIBITIONS/DESIGNS ON A REGULAR BASIS

DESIGN BASED APPLICATIONS HAVE BEEN FOR DESIGNERS TO ATTEND MILAN AND ICFF FAIRS. THE FUNDING SUPPORTS:

- > TRAVEL COSTS
- > FREIGHTING OF WORK
- > PRESENTATION OF WORK.

CREATIVE  
NEW ZEALAND

→ CNZ HAVE VARIOUS CONTESTABLE FUNDING MODELS FROM QUICK RESPONSE GRANTS (\$7,500) THROUGH TO ARTS GRANTS PATHWAYS (\$65,000)

CNZ HAVE SEEN AN INCREASE IN DESIGN BASED APPLICATIONS IN RECENT APPLICATION ROUNDS. THESE ARE MOSTLY FURNITURE BUT ALSO INCLUDE FASHION AND PRODUCT DESIGN. → THESE ARE YOUNG DESIGNERS STARTING OUT OR ESTABLISHED PRACTITIONERS DOING SOMETHING DIFFERENT FROM THEIR INITIAL SOURCE OF INCOME.

→ FUNDING (DESIGN SPECIFIC) APPLIES TO THE INITIAL DESIGN PART OF A PROJECT AS WELL AS THE PUBLIC PRESENTATION OF WORK. → IT DOES NOT SUPPORT COMMERCIAL PRODUCTION.

### NOTE:

IF A DESIGNER IS CONSIDERING APPLYING FOR FUNDING AT ANY STAGE - THE SOONER THEY MAKE CONTACT WITH CNZ THE BETTER SO THEY ESTABLISH A TRACK RECORD.

# RESEARCH INTERVIEW SUMMARY

FIND YOUR NICHE AND DO IT WELL.

DON'T START OUT TRYING TO DO EVERYTHING AT ONCE. START OUT WITH <sup>SOMETHING</sup> SIMPLE AND DON'T CONVINCE PEOPLE.

BELIEVES IT IS A GOOD TOPIC THAT IS BECOMING MORE VALUABLE. WITH LASER/CNC/STEREOLITHOGRAPHY TECHNOLOGY.

ARTIFAKTS PRODUCT WAS DEVELOPED OUT OF FRUSTRATION

COMPONENT/MATERIAL FLEXIBILITY WAS KEY TO THE ARTIFAKTS RANGE

## COLLABORATIONS:

- > PRINTERS
- > TOOLMAKERS
- > MODEL MAKERS
- > CNC/LASER CUTTERS
- > CLIENTS.

THE BEST YOU CAN FIND.

BELIEVES THERE ARE 2 POSSIBLE DIRECTIONS FOR ME.  
> SPECIALIST PRODUCT  
> INTIMATE CRAFT PRODUCT.

DESIGNERS NEED TO PLAY AND HAVE TIME (AND PARTNERS TO EXPERIMENT WITH)

YOU CAN BE WORLD FAMOUS FROM NEW ZEALAND. YOU NEED TO CONTACT PEOPLE TO BE NOTICED - KNOCK ON DOORS ETC. CONNECTIONS ARE SO IMPORTANT.

PETER HAS BEEN ENTREPRENEURIAL IN THE WAY HE HAS WORKED AND IDENTIFIED OPPORTUNITIES. → HE HAS BUILT/SOLD COMPANIES AND WORKED ON AN EQUITY BASIS THROUGHOUT HIS CAREER.

NOTHING IS FOREVER - HE GETS BORED.

PETER HAYTHORTYWAITE

NOTE: IT IS UP TO YOU. COLLABORATIONS. ENTREPRENEURIAL APPROACH. KNOCK ON DOORS. FIND YOUR NICHE AND DO IT WELL.

RESEARCH INTERVIEW SUMMARY:

SIMON DID SHIP PRODUCTS TO THE USA - BUT SHIPPING AND INSURANCE BECAME TOO EXPENSIVE - WITH A LOT OF DAMAGED GOODS.

JAPANESE RELATIONSHIP WAS DEVELOPED THROUGH SIMON BEING BOLD / CONTACTING THEM.

SIMON JAMES DID HAVE AND INTERNATIONAL PRESENCE (MILAN, IFF, 100% DESIGN) IN THE PAST AND WOULD LIKE TO BUILD THAT AGAIN.

A JAPANESE COMPANY DID MAKE SOME OF HIS PRODUCTS UNDER LICENSE

NOTE: DIFFERENTIATED STYLE / MANUFACTURING NETWORK, EXPORT/PRODUCTS. → CRUCIAL FOR SUCCESS. / CONTACT PEOPLE.

EFFICIENT AND APPROPRIATE APPROACH TO DESIGN - IT'S A BUSINESS  
SIMON JAMES IS LOOKING AT A RANGE OF SMALL/COMPACT PRODUCTS FOR EXPORT. AND UTILISING HIS MANUFACTURING CHAIN TO MAKE THESE

MANUFACTURING CHAIN

FURNITURE DESIGNER AND AGENTS FOR EUROPEAN BRANDS

MAIN MARKET IS COMMERCIAL INTERIORS AND SUPPLIES JAMES ETC.

SIMON JAMES SUPPLIES MOSTLY THE NEW ZEALAND MARKET.

INTENTIONALLY DEVELOPED HIS BRANDS AND PRODUCTS TO BE INTERNATIONAL (EUROPEAN) IN STYLE.

↓  
HE BELIEVES THE KIWIANA STYLE WILL DATE

↓  
HE DESCRIBES HIS WORK AS FUNCTIONAL / WITH SPECIAL / UNIQUE DETAILS

© J. KLENNER 11.10.2009

# RESEARCH INTERVIEW SUMMARY:

OPPORTUNITIES: UNIQUE MATERIALS TO NEW ZEALAND + END USER PERCEPTIONS THERE ARE OF NEW ZEALAND.

KEY STEPS ARE (THROUGH A SINGLE MINDED VISION)

- UNDERSTAND OPPORTUNITY
- CREATING SPECIFICATION
- DELIVERING.

TRUBRIDGE =  $m/c =$  [CRAFTED ONE-OFF].  
 $= m/c =$

MANUFACTURING METHODOLOGY SHOULD NOT BE USED AS AN INDICATOR OF WHETHER SOMETHING IS MASS PRODUCED OR CRAFTED

DESIGN IS ABOUT QUALITY OF EXECUTION. ABOUT MEETING THE END USER NEED. IT IS ABOUT MARGIN - NOT ABOUT VOLUME

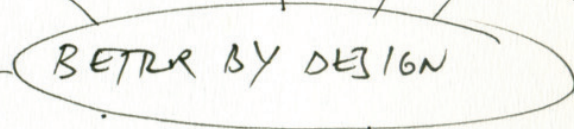

VOLUME SHOULD NOT BE USED TO DISTINGUISH BETWEEN CRAFT AND DESIGN (SUPER YACHT IS NOT A CRAFT ITEM)

HATRICK-SMITH BELIEVES THIS STUDY BEING AN INVESTIGATION INTO DEFINING A SPACE THAT I CAN OCCUPY THAT IS ~~NOT~~ UNIQUE AND DIFFERENTIATED. — WITH PERHAPS NOT TO MANY OTHERS — WHERE I CAN DESIGN OBJECTS, THAT MAY BE ONE-OFF.

DESCRIBES THE PRODUCTS THAT TRUBRIDGE PRODUCES AS FINELY CRAFTED ITEMS — THIS IS DIFFERENT TO HANDCRAFT. → THERE ARE SOME HIGH TECH. MANUFACTURING. PROCS INVOLVED.

NOTE:

- > MARGIN NOT VOLUME
- > VOLUME IS DETERMINED BY PRODUCT CATEGORY.
- > DEFINING/DESCRIBING/UNDERSTANDING WHAT IS MEANT BY CRAFT OR CRAFTED IS ESSENTIAL TO THIS STUDY.

↓ THE WORD 'CRAFT' TO HATRICK-SMITH CONJURES UP IMAGES OF BASKET WEAVING AND HAND SHAPING WHICH HE BELIEVES IS NOT THE CASE WITH TRUBRIDGE

© J. KLENNER 11.10.2009

# RESEARCH INTERVIEW SUMMARY:

## IMPORTANT STEPS TO ACHIEVE SUCCESS:

- > START / LEARN FROM NZ MARKET.
- > POINT OF DIFFERENCE
- > BUSINESS ACUMEN
- > RESEARCH MARKET / END PRICE STRATEGY.
- > ATTEND TRADE SHOWS PRIOR TO EXHIBITING
- > ~~LISTEN~~ PARTNER WITH RETAILERS. LISTEN TO /

TRUBRIDGE IS LEADING - HIS PRODUCTS ARE EASY TO SCALE COMPARED WITH CERAMIC + GLASS ETC

MORA IS WORKING WITH LEADING INDUSTRY EXPERTS THIS AREA:  
HOGGINS; TRUBRIDGE  
↑ PETER COLLIS. ETC.

MORA INTRODUCES DESIGND CRAFT -> AT LEAST ONE PROCESS IS ACTUALLY OUTSOURCED BUT STILL HAS AN ELEMENT OF BEING TOUCHED BY HAND

ESSENZE

LIGHTING PRODUCTS ARE BIGGEST SELLERS OVERSEAS

ESSENZE ARE CREATING THEIR OWN PRODUCTS USING SELECTED DESIGNERS

TRUBRIDGE PRODUCTS ARE REFRESHING IN A WORLD OF ~~VERY OVER MANUFACTURED DESIGNED PRODUCTS~~ RETAILER / DISTRIBUTOR

OF NEW ZEALAND MADE PRODUCTS / DESIGNED CRAFT PRODUCTS RETAIL (GALLERY) STORES + DISTRIBUTIONS

FOCUS IS MOSTLY RESIDENTIAL BUT HAS A PRESENCE IN HIGH END RECEPTION / BOARD ROOM. COMMERCIAL

## DIFFERENCE BETWEEN CRAFT AND DESIGN

CRAFT = MADE FROM PASSION AND WORKMANSHIP ABILITY

DESIGN = CONSCIOUS PROCESS (INCLUDING RESEARCH)

\* PROCESS RESULTS IN RIGHT PRODUCT, PRICE ETC FOR THE RIGHT MARKET.

YOU CANNOT SCALE CRAFT EASILY AND YOU CAN SCALE DESIGN

SCALABILITY = BEING TOUCHED BY A NUMBER OF PEOPLE DURING THE MAKING PROCESS

## DIFFERENTIATED BY:

- > ROMANCE OF NEW ZEALAND.
- > PRODUCTS ARE UNIQUE AND NOT NECESSARILY REPLICATED DOWN THE ROAD IN ANOTHER DESIGN STORE
- > BEING INVOLVED WITH PRODUCTS EXCLUSIVELY FROM POINT OF ORIGIN THROUGH TO END CUSTOMER (VERY RARE)

RESEARCH INTERVIEW SUMMARY:  
(RAW)

DAVID TRUBRIDGE

HAS A TEAM OF DESIGNERS AND CRAFTERS.

COMPUTERS HAVE BEEN A KEY PART OF HIS SUCCESS.

- > DESIGN (CAD/CNC ETC)
- > INTERNET (COMMS, PROMOTION ETC)

BECAUSE HE IS BASED IN NEW ZEALAND IT IS IMPORTANT THAT HE ~~HE~~ HE ATTENDS FAIRS SUCH AS MILAN TO KEEP HIS PROFILE - WITH NEW WORK - MAGAZINES ONLY FOCUS ON THE "NEW!"

HE BELIEVES A KEY PART OF HIS SUCCESS IS HIS NEW ZEALAND STORY. AND AESTHETIC.

HE HAS NEVER LOOKED AT TRENDS OR COPIED A STYLE (EG. EUROPE)

BELIEVES IT IS ESSENTIAL FOR DESIGNERS TO PLAY AND TO EXPLORE (WITH THEIR HANDS) COCAL LIGHT IS A RESULT OF THIS

TRUBRIDGE BELIEVES A FUNDAMENTAL ASPECT TO CRAFT IS THE WORD CARE - ~~NOT PRODUCING CRAPPY PRODUCTS~~

BELIEVES THE CREATIVE PROCESS TO INVOLVE ART DESIGN AND CRAFT - DEPENDING ON THE OBJECT / PIECES DETERMINES THE QUANTITIES OF EACH (INPUT OF EACH)

ART = YOUR VOICE / VOCABULARY  
WHAT YOU ARE SAYING

DESIGN = HOW YOU ARTICULATE THAT VOICE

CRAFT = MAKING.

BALANCE OF THESE ARE KEY OR YOU WILL GET ART FOR ART'S SAKE OR DESIGN FOR DESIGN'S SAKE.

BIG BREAK  
CAME IN 2001  
WITH THE BODY RATT  
PRODUCT EXHIBITED AT  
MILAN -> LICENSE AGREEMENT  
THROUGH CAPPELLINI.

AFTER THIS HE DECIDED TO STAY  
IN NEW ZEALAND - NOT MOVE TO EUROPE  
TO BE A HOT SHOT. -> PERCEPTION OF  
NEW ZEALAND IN EUROPE IS THAT IS EXTREMELY  
FAR AWAY. -> AND THERE ARE TAUNTED DESIGNERS  
IN EUROPE - WHY BOTH?

WORKS IN WOOD BECAUSE THAT  
IS WHAT HE KNOWS -> IT  
IS A MATERIAL THAT DOES NOT  
REQUIRE COMPLICATED MANUFACTURING  
PROCESSES

RESEARCH INTERVIEW SUMMARY:  
(RAW)

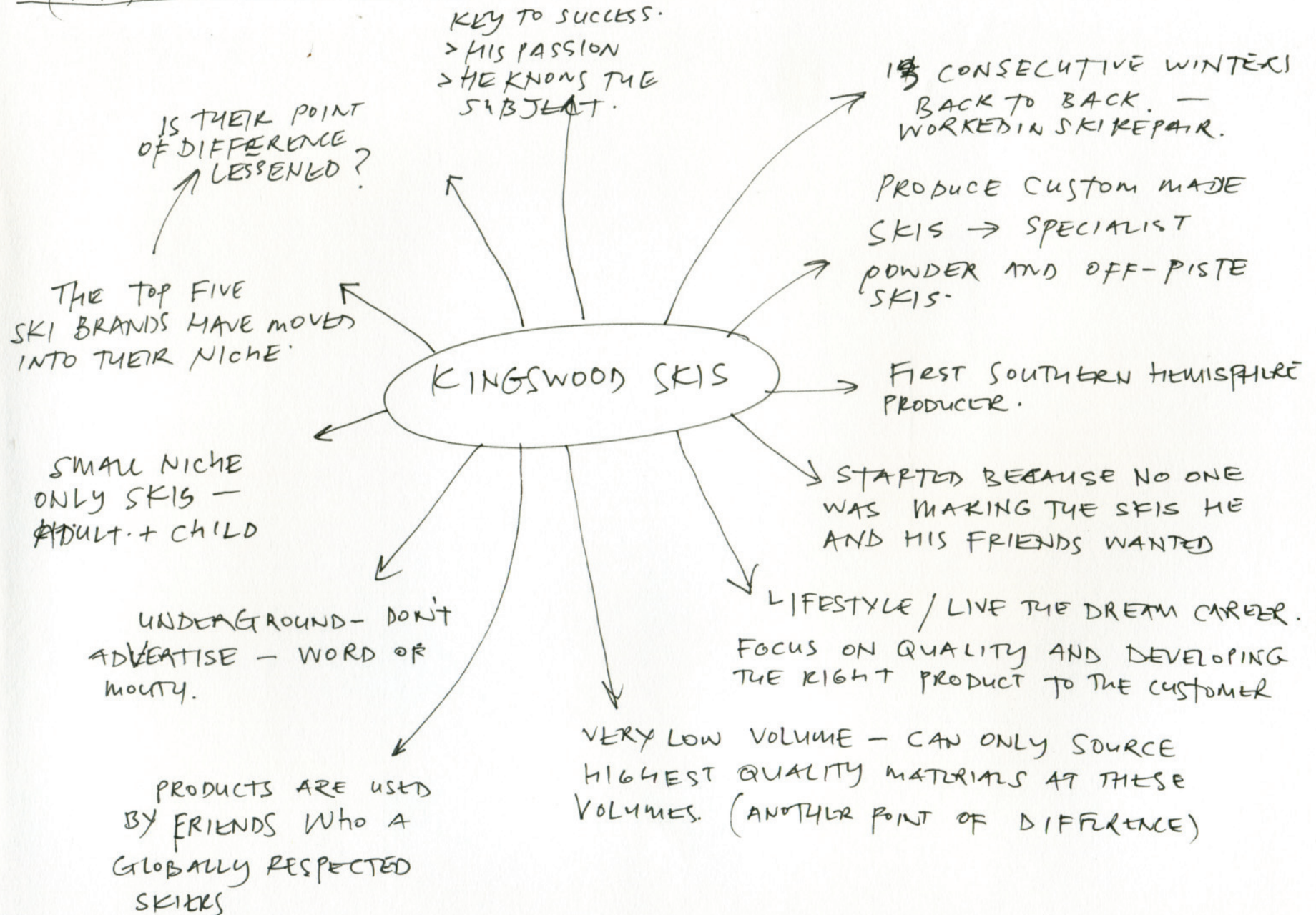

3 STAGE CRITERIA

1	2	3
GOAL.	REQ.	DETAILS



POSSIBLE AREAS

OUTDOORS. / BEACH. / WATER

FOOD.

OUTDOORS.

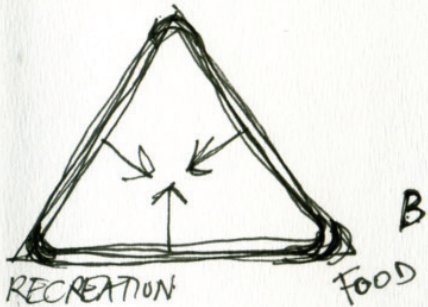

①

"HIGH VALUE"

OUTDOORS



RECREATION

Food (wine)

Compact / EASY SHIPPING.

High Quality niche - Designed Craft / LONGEVITY

IDENTIFY A EXHIBITION TO ATTEND: (TOO LOOSE FOR THIS STAGE)

① SUBJECT THAT I KNOW / PASSIONATE ABOUT / KNOWLEDGABLE ABOUT

SUBJECT WITH STRONG INDUSTRY EXPECTS POTENTIAL COLLABORATIONS → BE ENTREPRENEURIAL.

① ② → SOMETHING PEOPLE ASSOCIATE WITH NEW ZEALAND.

NOT BE AN OVERMANUFACTURED ITEM → EG. BE WITHIN THE DESIGNED CRAFT ZONE

② TRIAL IN NEW ZEALAND WITH AN INTERNATIONAL STRATEGY.

→ MATERIALS / PROCESSES.

OPPORTUNITIES  
THAT EXIST. → FOR DESIGNERS

- HIGH VALUE
- NEW ZEALAND STORY
- NICHE / PERSONALITY
- COLLABORATIONS.

OUTDOORS

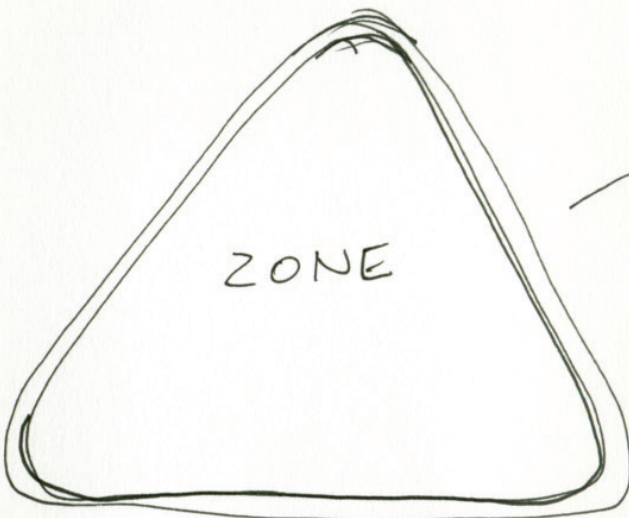

HOME AND BEACH

THEMES

- > A DAY ON THE BEACH
- > AN AFTERNOON IN THE GARDEN
- > HOLIDAY AT HOME?

RECREATION

FOOD  
WINE.

NEW ZEALAND LIFESTYLE + CULTURE.

→ OUTDOOR / RELEXATION / LIFESTYLE / LAYED BACK.

© Jason Klenner 11/10/2009

MARC NEWSON WAS DESIGNING JEWELLERY BEFORE HE DESIGNED THE METAL LOUNGER.



CHANGE OF SCALE?

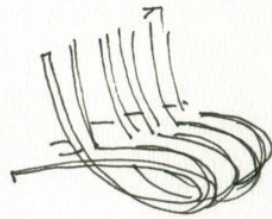

LOOK AT WHAT WE ARE GOOD AT. → CARBON FIBRE  
→ ROTO MOULDING  
→ GLASS-MAKING

ROTO MOULDED OUTDOOR FURNITURE

NEWSON AND TRUBRIDGE BOTH DESIGNED WOODEN/BENT FURNITURE AROUND THE SAME TIME → HOW DID HE BECOME RECOGNISED?

DISCUSSION WITH TONY AND MARC.  
12 OCTOBER 2009

"OUTDOOR" IS GOOD IF IT COMES FROM NEW ZEALAND AND WE DO THIS A LOT.

↓  
THIS IS WHAT THE NEW ZEALAND PRODUCT/STYLE IS? PERHAPS

OUTDOOR:

- BBQ.
- BEER BREWING.
- OUTDOOR FURNITURE
- PICNIC

INTEGRATED VS NON-INTEGRATED SOLUTIONS.

→ SLICK DESIGNS (STYLED LIKE SEYMOUR POWELL) VS A STAINLESS STEEL BUCKET.

© Jason Klenner 11.10.2009

"SEARCHING FOR A CONTRADICTION / POINT OF DIFFERENCE"

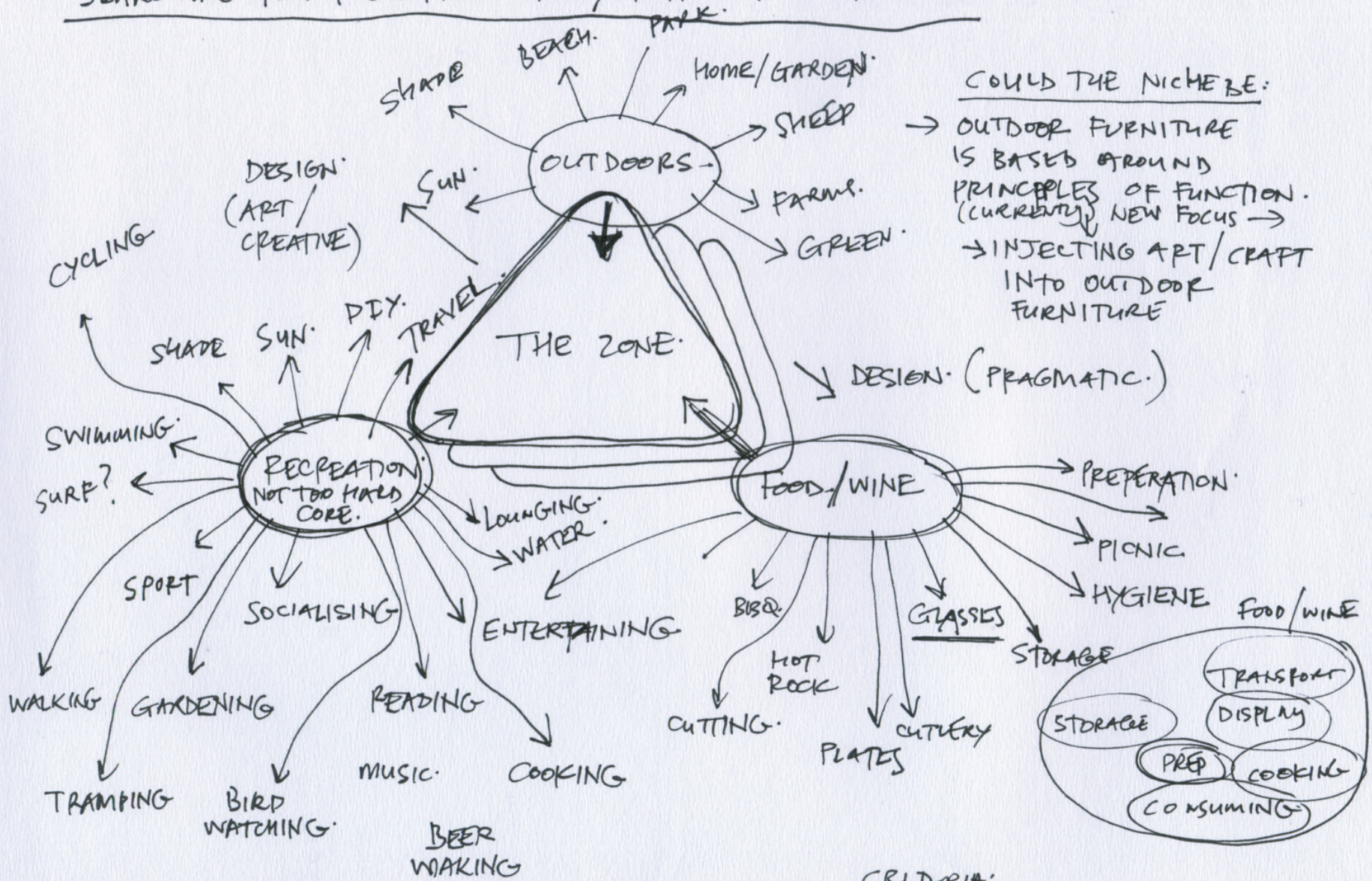

COULD THE NICHE BE:

- OUTDOOR FURNITURE IS BASED AROUND PRINCIPLES OF FUNCTION. (CURRENTLY) NEW FOCUS →
- INJECTING ART/ CRAFT INTO OUTDOOR FURNITURE

DESIGN. (PRAGMATIC.)

WHAT IS NZ. RENOWNED FOR:

- BEACH - LORD OF THE RINGS
- OUTDOORS - RUGBY.
- WINE -

CRITERIA:

- MUST BE SOLD/ LICENCED.
- MUST ESTABLISH A NAME
- MUST ENABLE FLEXIBILITY IN THE FUTURE.

© JACON KLEINER 07. DEC. 2009



OUTDOOR  
OVERSIZED  
SLAB PLATE.

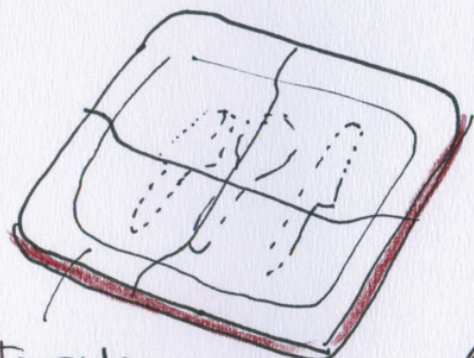

Under  
side of  
plate

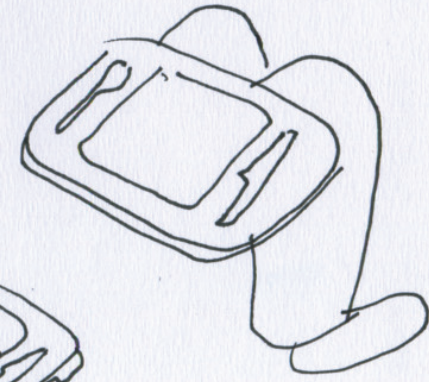
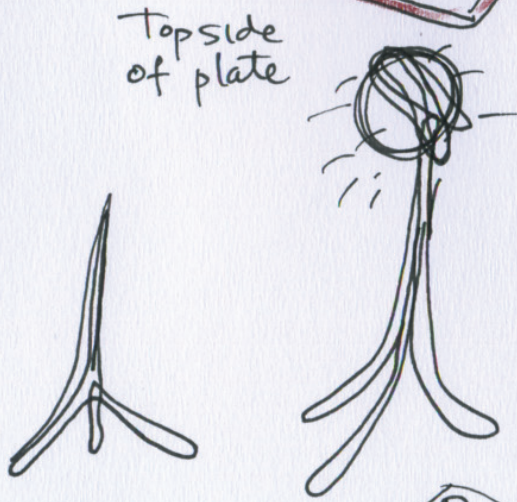
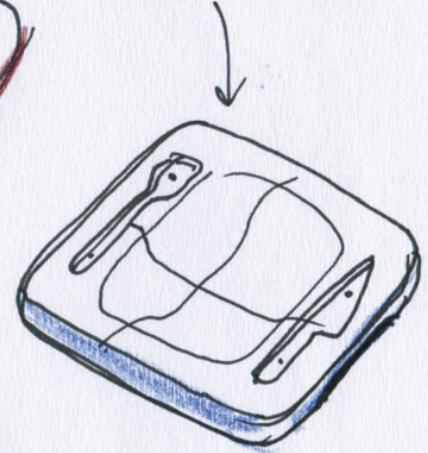
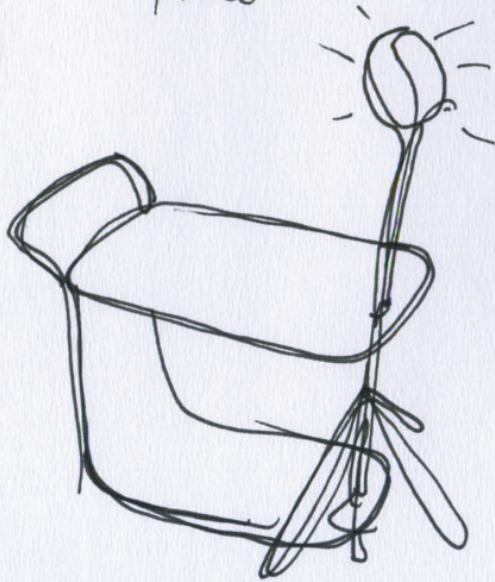

© JASON KLENZ 7-Dec-2009

THREADS

- SHADE + OUTDOOR + EATING. = NEW SHADE TABLE.
- GARDEN + LOUNGING + GREEN = NEW / HIGH VALUE OUTDOOR CHAIR.

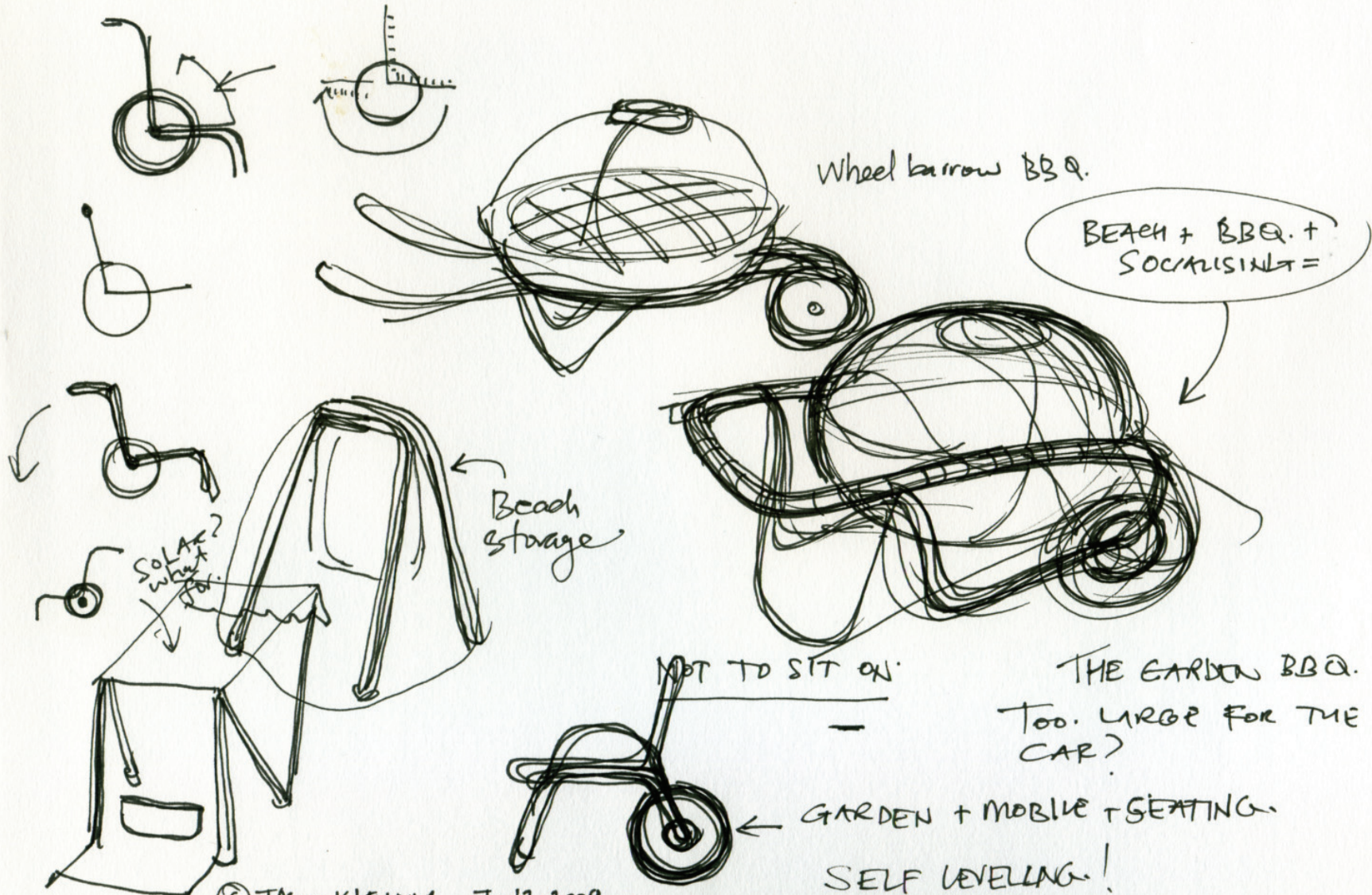

© JASON KLENNER 7.12.2009

PLACE IN KITCHEN.  
AS A CUPBOARD.  
MODULE

TABLE TOP/  
NESTING  
BAMBOO  
FRAMES

INDOOR  
OUTDOOR  
CARDBOARD

INDOOR/  
OUTDOOR  
RESTMENT

OUTDOOR CHAIR

FOLDING  
UP SEATING/  
OUTDOOR CHAIR

MODERN DAY  
CHILI BIN

BEACH. +  
NEW MATRAYS. +  
FOOD/SOCIALISING

WITH  
REINTERATED  
PLATS ETC.

OLD  
BASKET  
LIKE HOT  
PIE BALLOON.  
BAMBOO

VACUUM  
INSULATION  
VISIBLE  
EVERYDAY? → in house

ALUMINIUM CLADDING  
+ POWDER COATED METAL  
AND WICKER / FLAX

WICKER BASKET WITH INSULATION LINING. FABRIC!

© JASON KLENNER 7.12.2009

SIMILAR TO NEW STYLE NZ  
ARCHITECTURAL LETTER BOXES  
WHEELS

STORAGE

BRO

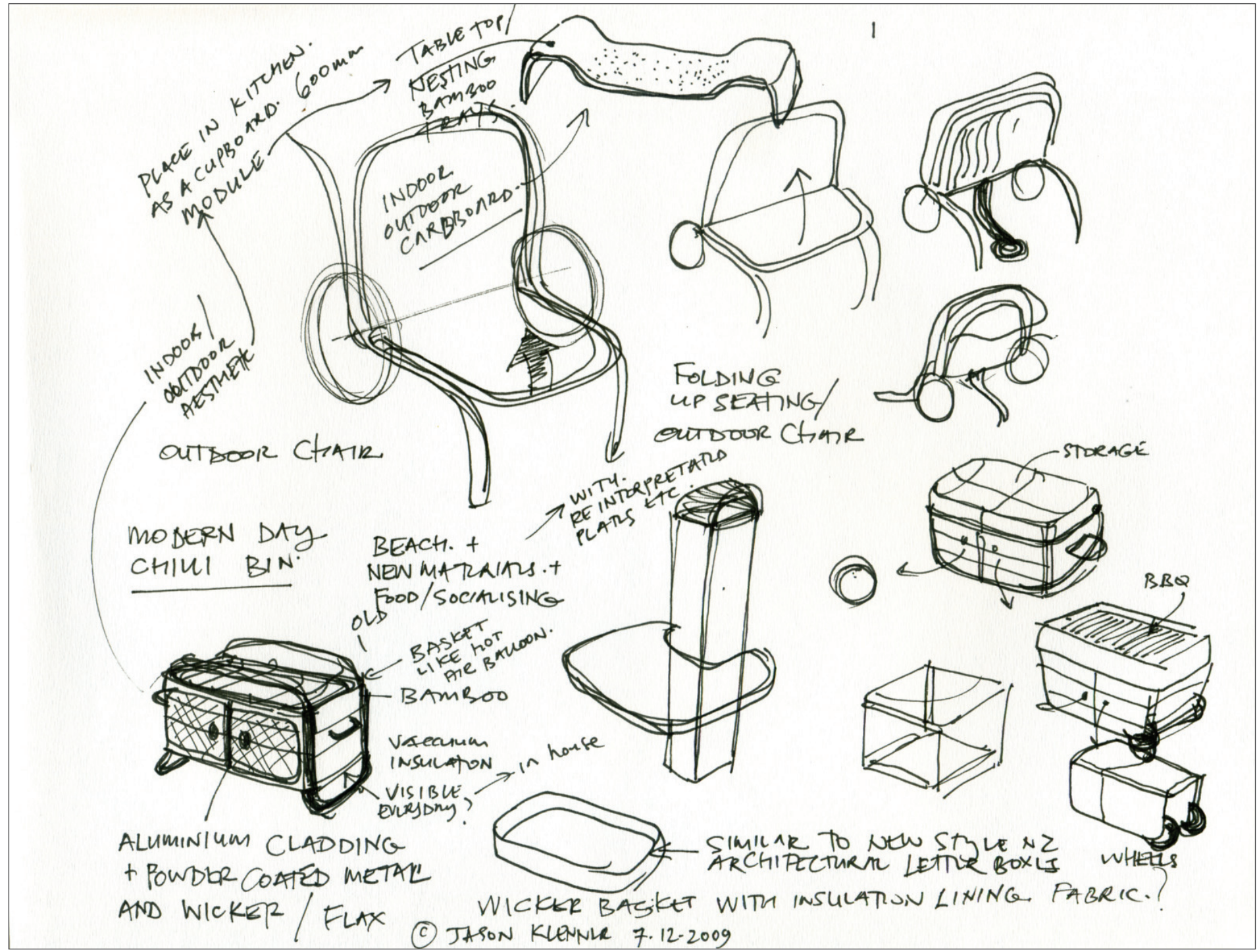

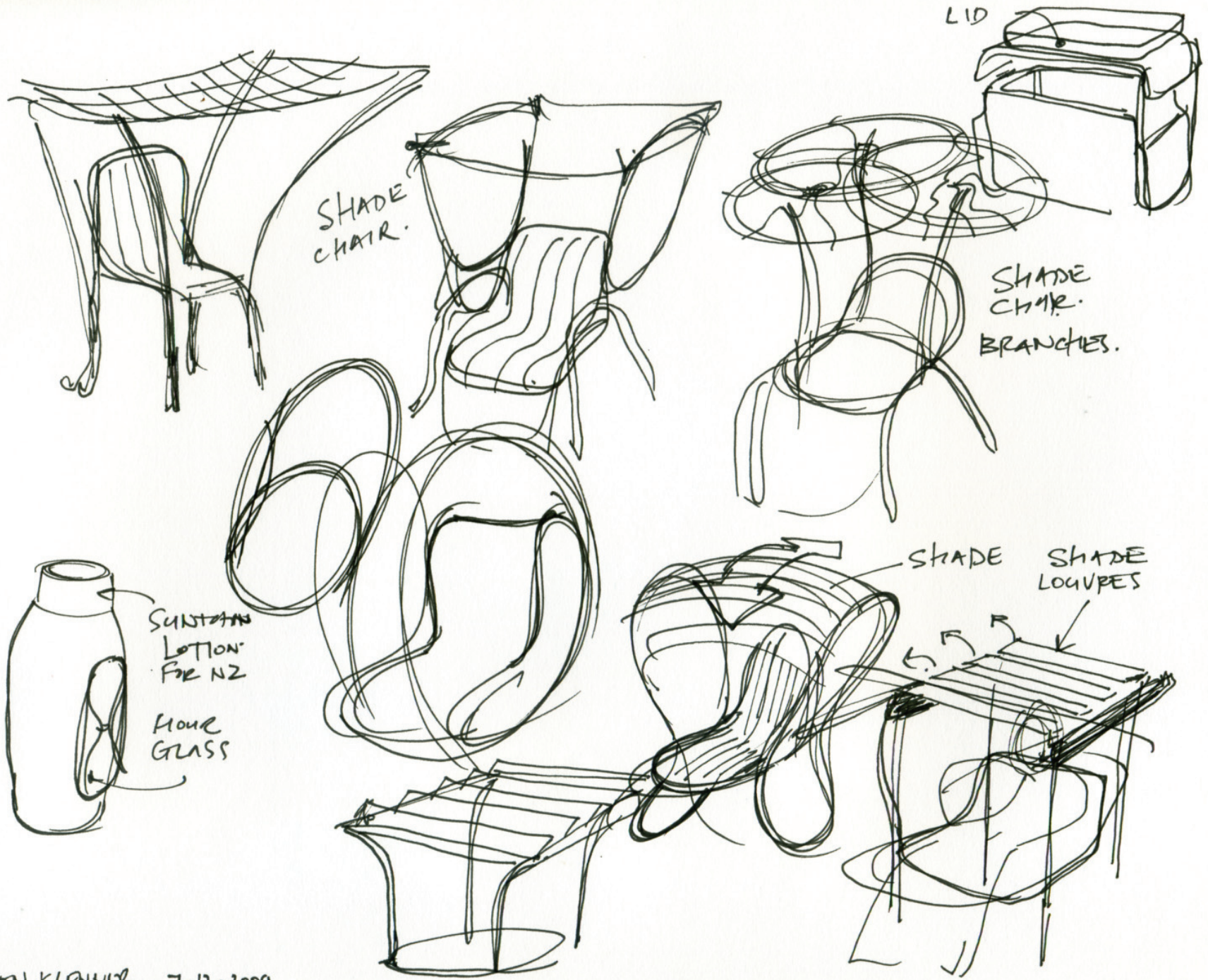

© JASON KLENNER 7.12.2009

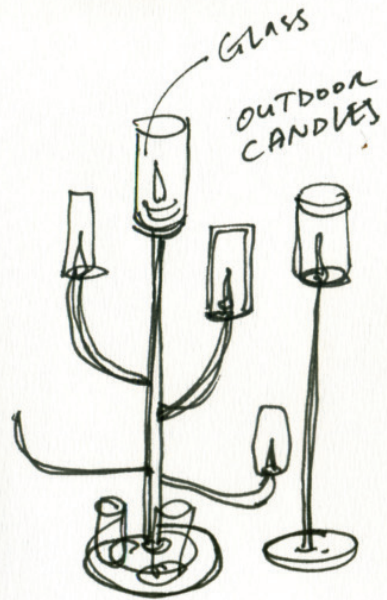

- FURNITURE  
- UTENSILS/TOOLS → CHALLENGE. IS FINDING A LICENSE.

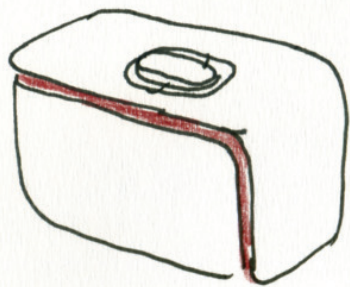

CHILI BIN 1.

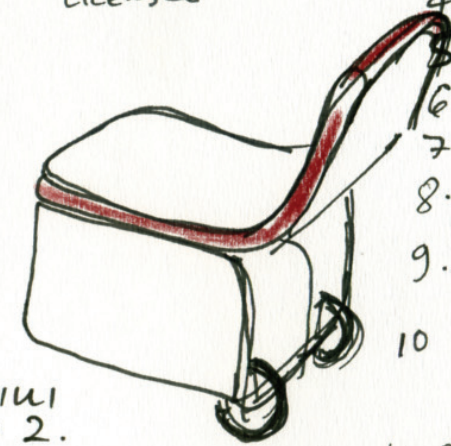

CHILI BIN 2.

1. CHILI BIN
2. CHAIR - WHEELS/MOBILE
3. CHAIR SHADE
4. DAY BED
5. OFFROAD BBQ.
6. SUNTAN LOTION TUBE
7. OUTDOOR COUCH
8. High Quality BBQ.?
9. High quality fold out chair. / FOLD-UP CHAIR.
10. outdoor lighting -  
OUTDOOR STORAGE/ceddy
11. OUTDOOR PLATS

TRAMPING  
+ LEISURE  
+ LOUNGE  
" DAY BED  
FOLD UP

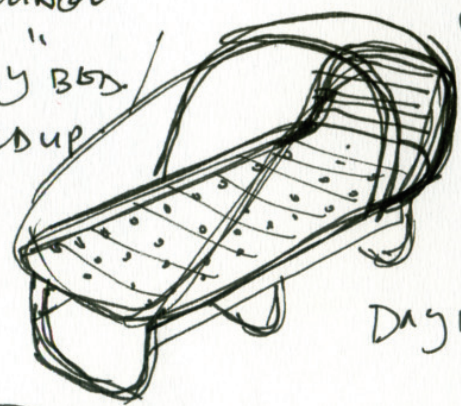
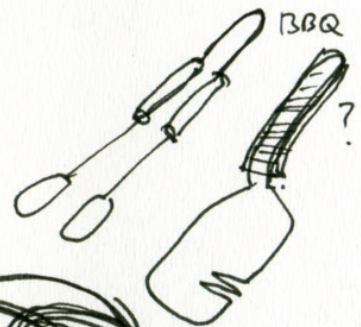

DAY BED.

materials  
Polystyrene

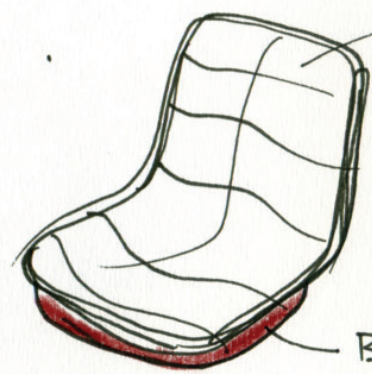
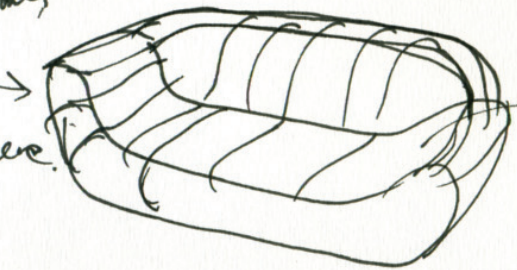

BEACH CHAIR.

BEAN BAG BASE

FORMED SEAT PAM

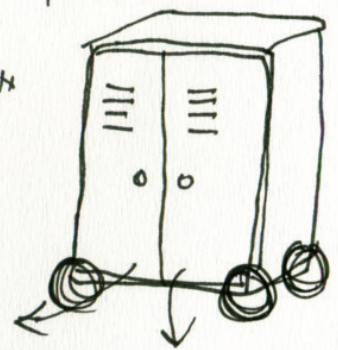

coffee



OUTDOOR LIGHTING.  
- low voltage.

High Quality  
Solar outdoor  
light. for  
Flors?

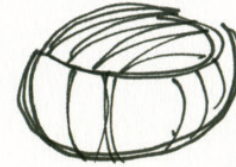
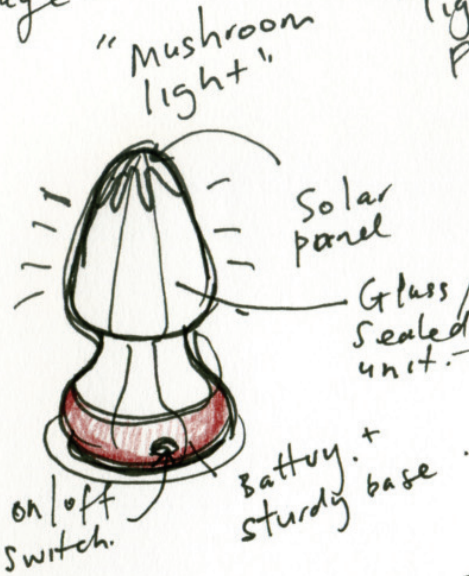
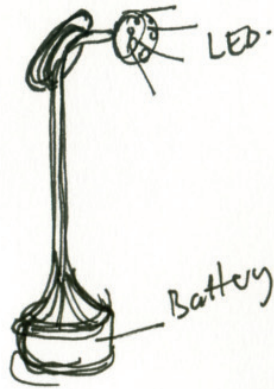

Solar  
Built-in  
light?

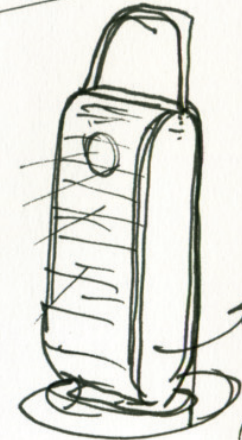
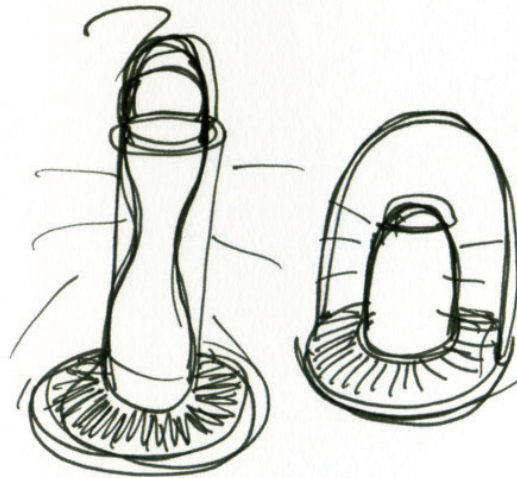
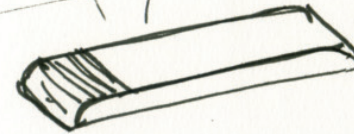

GLOW WORM  
LIGHT.

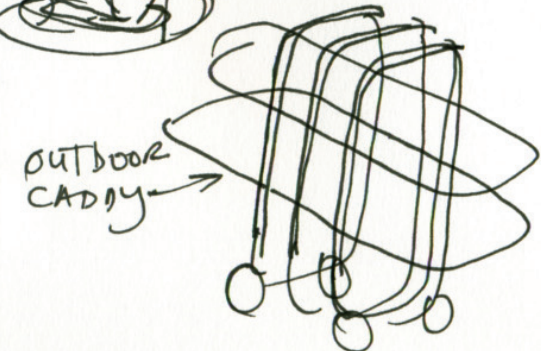

OUTDOOR  
CADDY

GRASS.

OUTDOOR CARPET

SITTING TOGETHER CHAIR

BBQ. + chilli bin. + light

LOOK AT HABITS. OF FURNITURE

THEMES:

SITTING TOGETHER.

COOKING

LIGHTING

FAMILY OF PRODUCTS

CHAIR / STORAGE / TABLE.

FURNITURE

ANOTHER THEME TREND

ANOTHER AREA TO THINK ABOUT.

STORAGE

TAKING THE INDOORS OUTDOORS

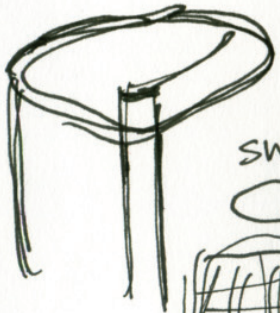

SWIVEL

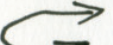

OUTDOOR SWIVEL.

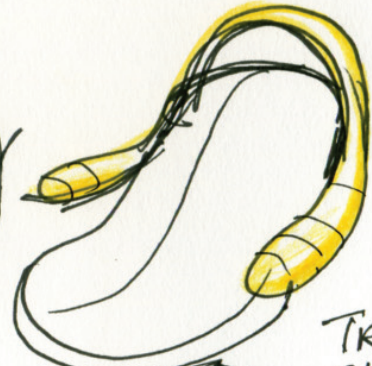

TROWEY CHAIR

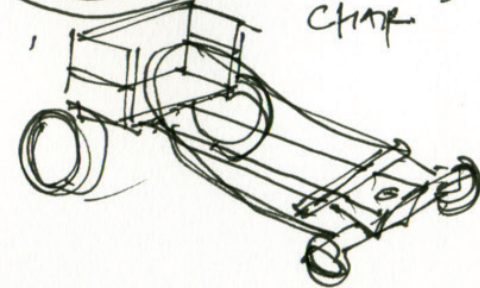

TOO PEDESTRIAN

© JASON KLENNER 8.12.2009

Remoteness  
Being so  
far away

Flying.

Sheep./lambs.

What was NZ renowned for 40 years ago? → Recent  
History.

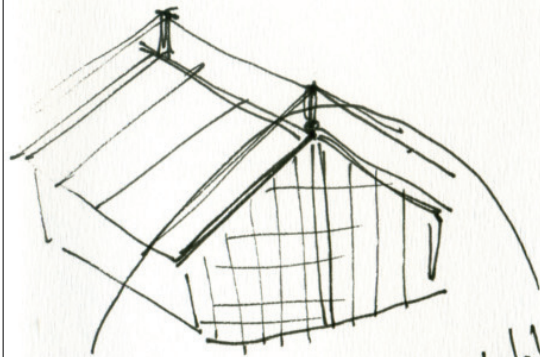

Rainbow Warner.

All blacks

Creating history.

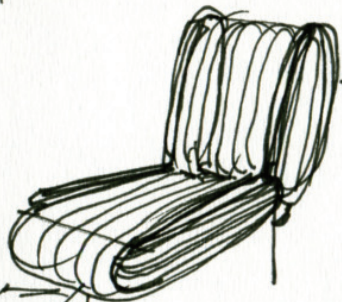

Hollow sections.  
BBQ CHAIR.

Retractable  
Keel.

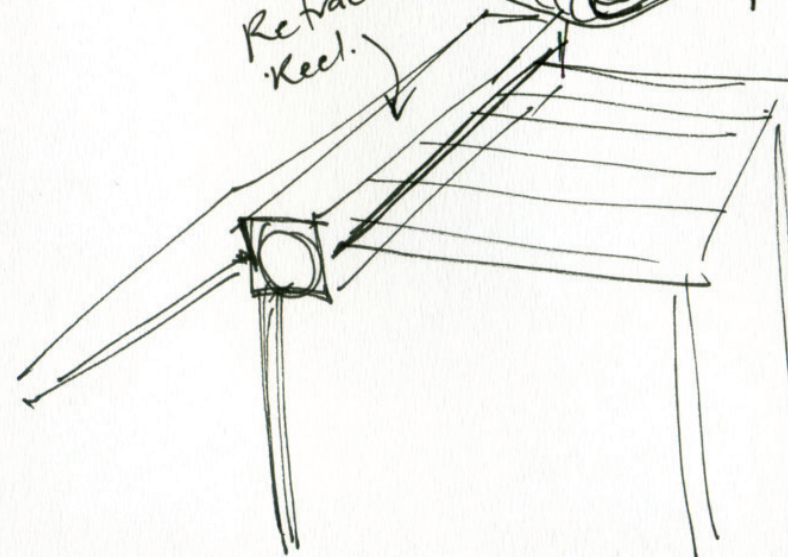

Camping

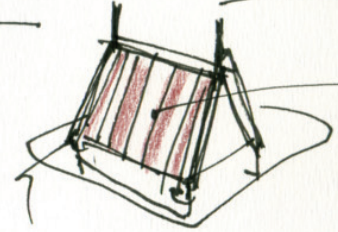

Retro  
tent for  
People. wanting  
CLASSIC  
Style

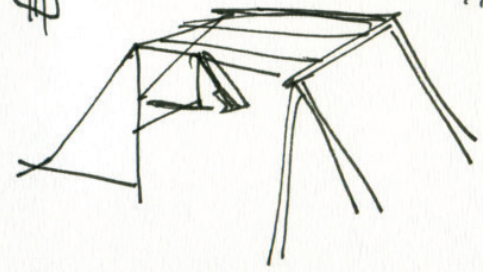

"Classic movement"

OR. TAKE THE OUTDOORS IN DOORS.

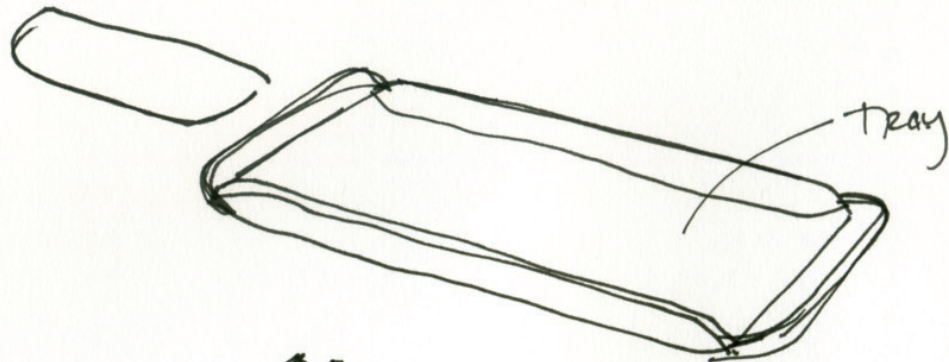

Cocktails.

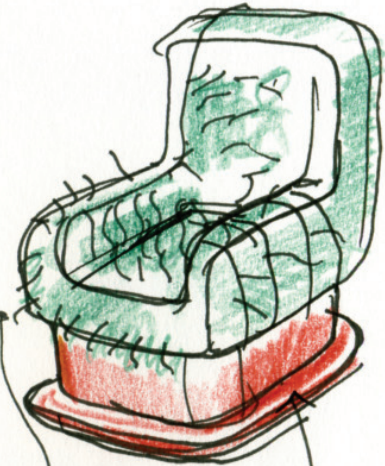
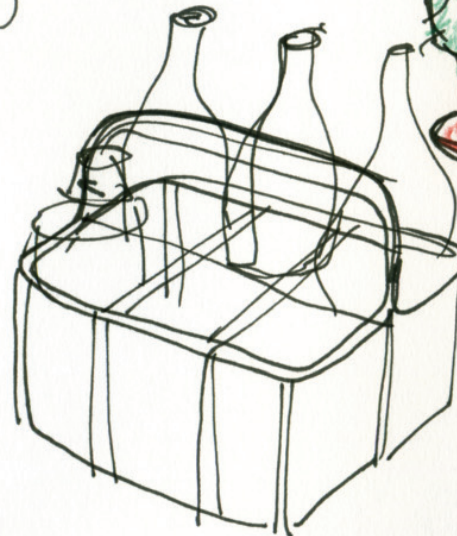

"Green" Chair.

terracotta.

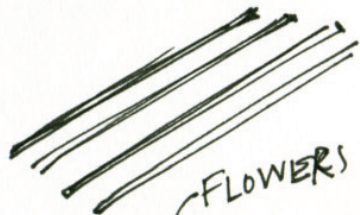

FLOWERS

BRING THE OUTDOORS INDOORS.



INDOOR/OUTDOOR CHAIRS IDEA FOR

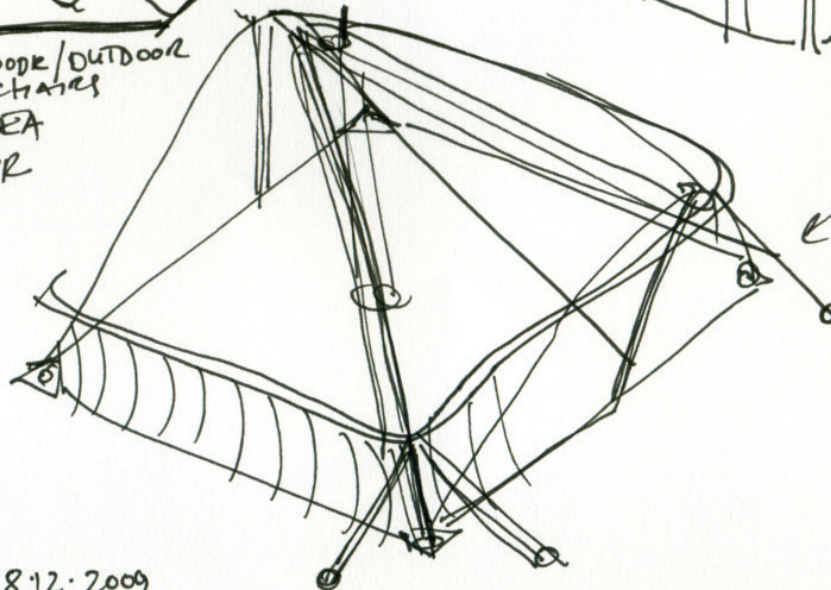
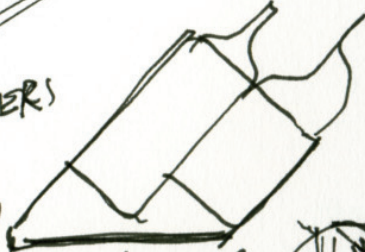

Beach Structures

shelters

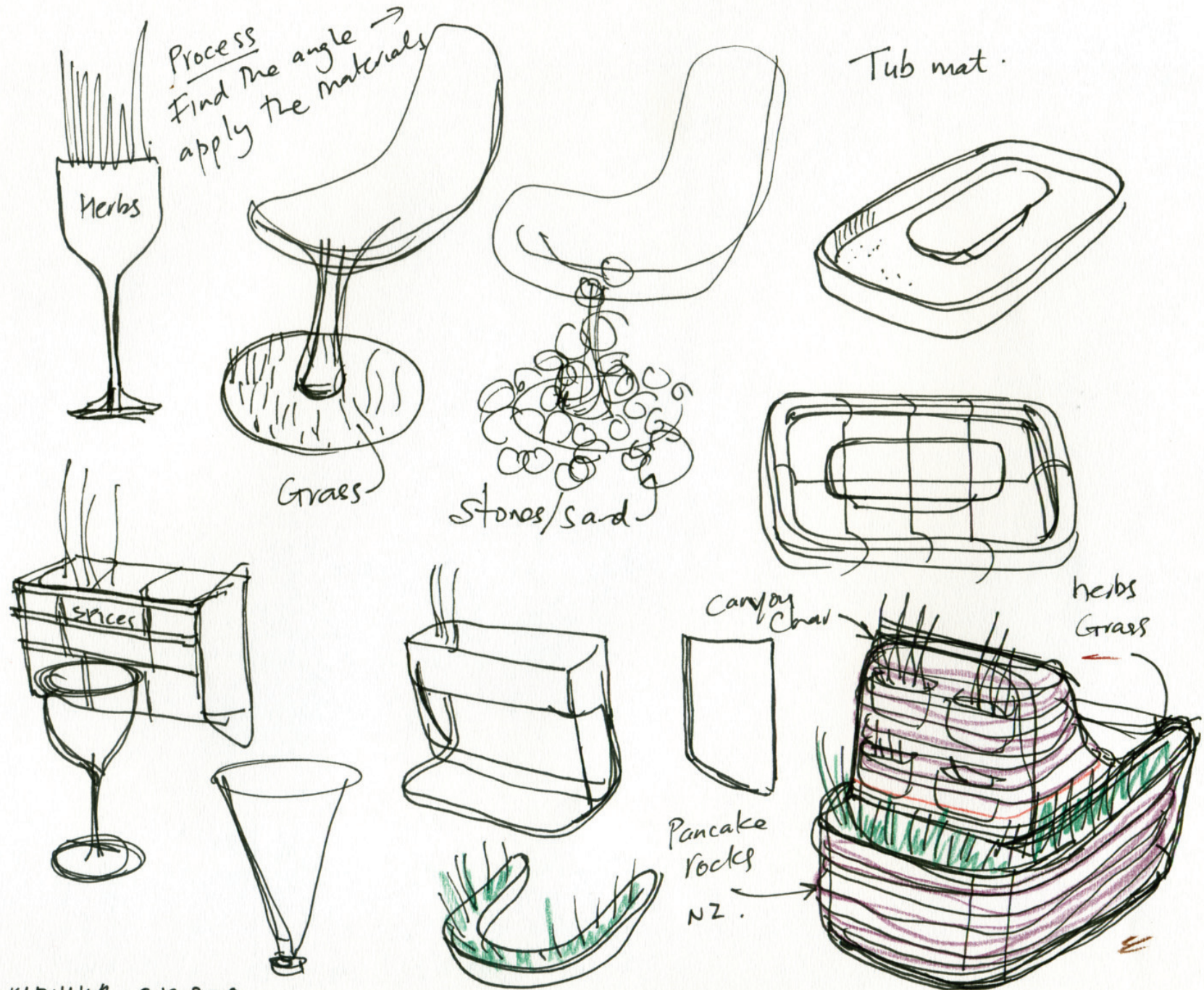

© JASON KLENNER 8-12-2009

OUTDOOR COUCH.

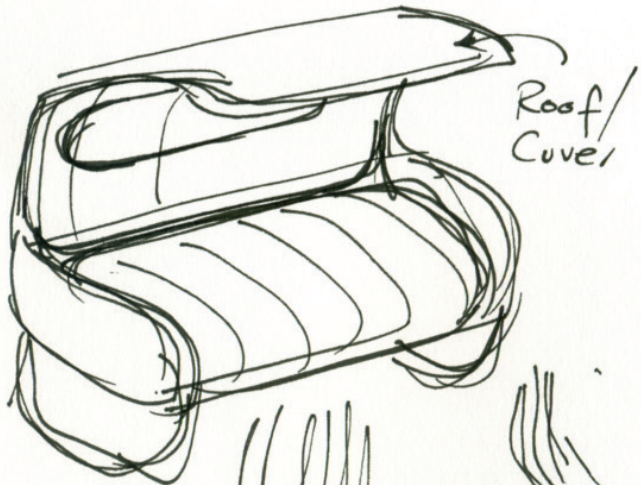
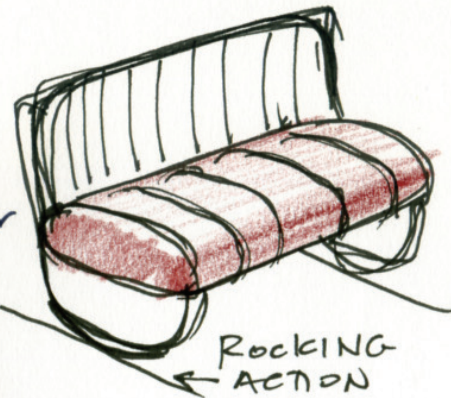
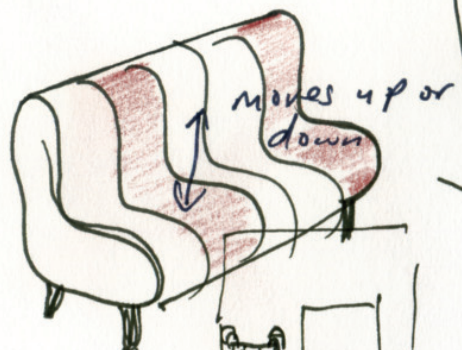

Super Modern architectural



Jason → furniture interiors  
→ wine/beer.  
↓ design ↓ food

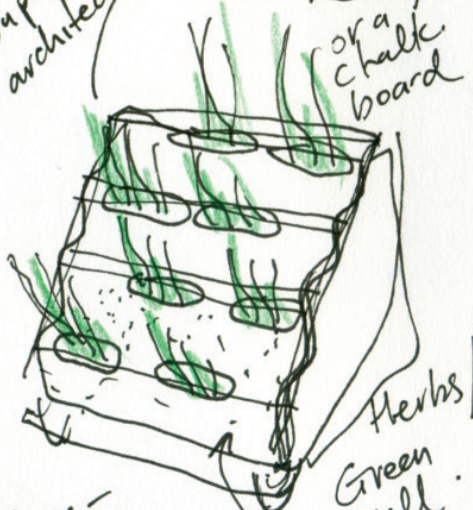

Fabric - like a painting analogy

Herbs Green wall hanging.

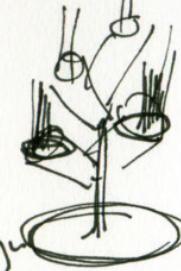
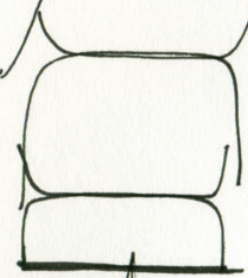
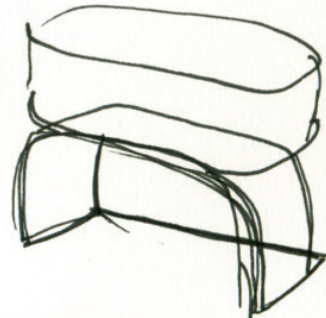

Art

design



© JASON KLENNER 8.12.2009

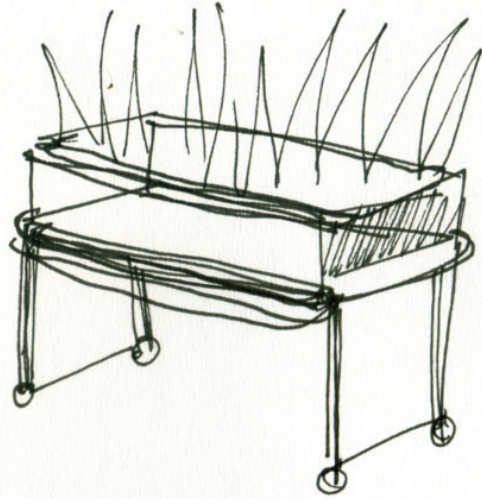

Bench top planter box.

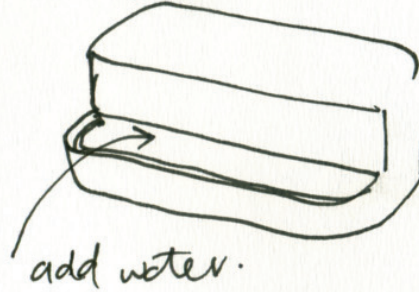

SOLAR SEATING

MAKING KEEPING THE SUMMER AS LONG AS POSSIBLE

OUTDOOR FIRE.

BBQ.

Cleaning is an issue

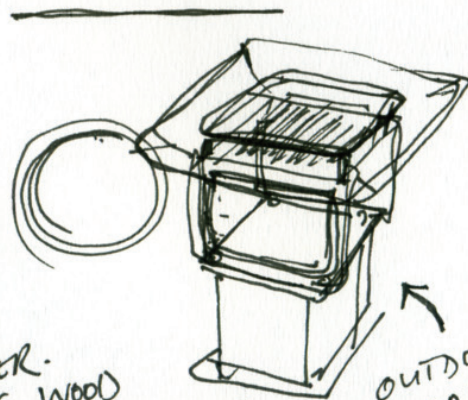
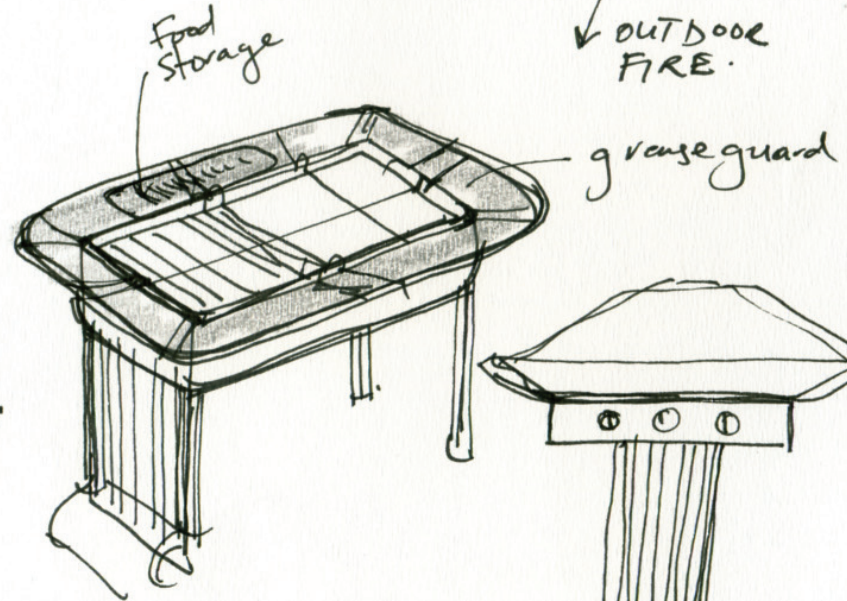

BBQ / BRAZIER. USING WOOD BURNER TECHNOLOGY

OUTDOOR WOOD BURNER.

Playing on NZ architecture.

© JASON KLENNER

8.12.2009

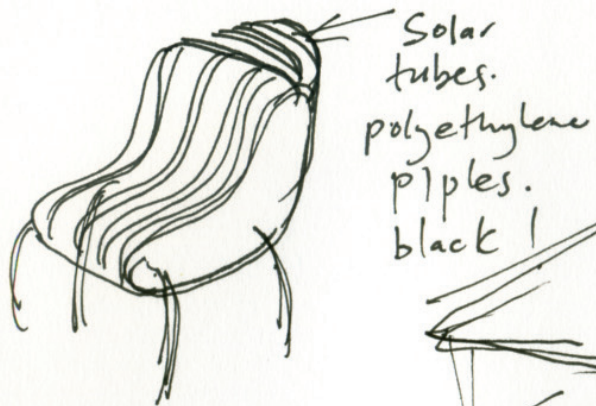

Laser cut sheets  
↓  
Flat pack  
↓  
COMBO "pizza oven"

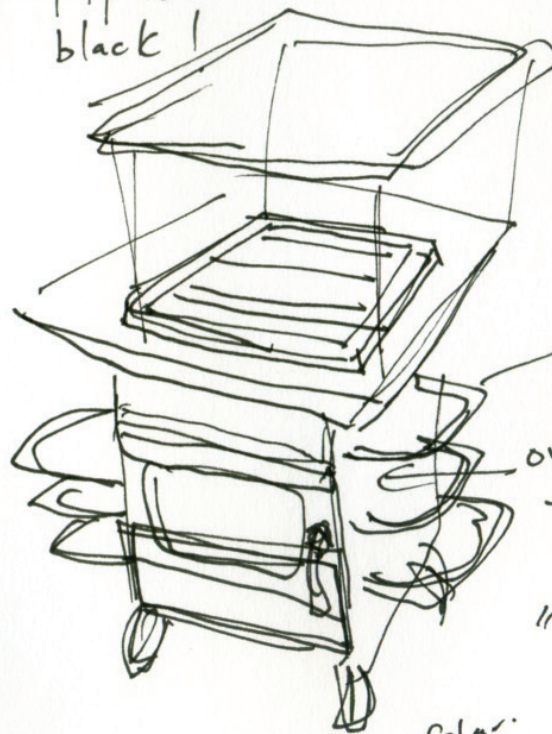

"outdoor wood burner"

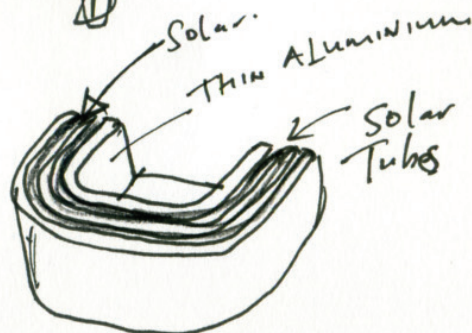

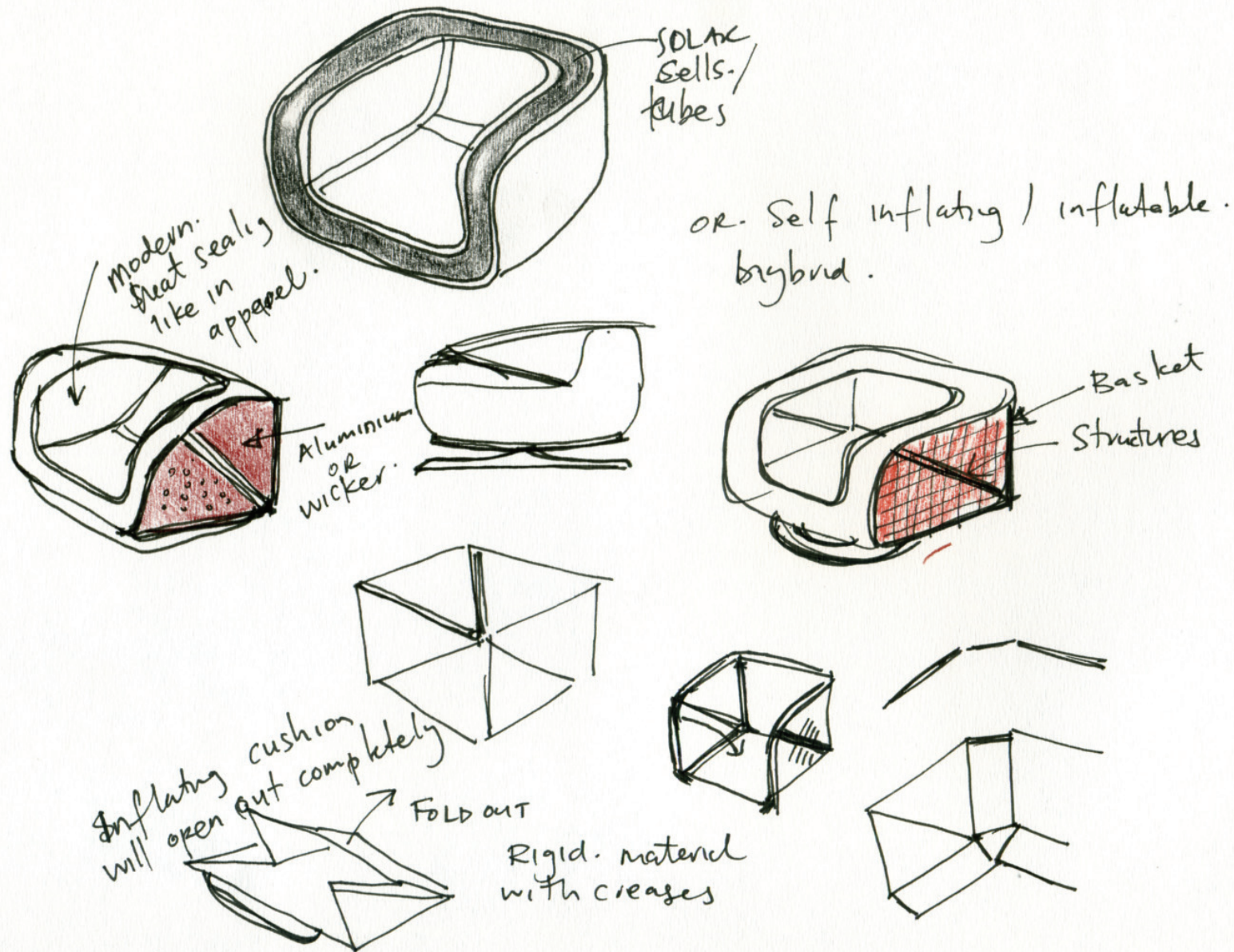

© JASON KLENMUR 8.12.2009

# INDOOR FLOWER/HERB FURNITURE

TAKING THE OUTDOORS  
INDOORS — IDEAL  
FOR SHORT SUMMERS.

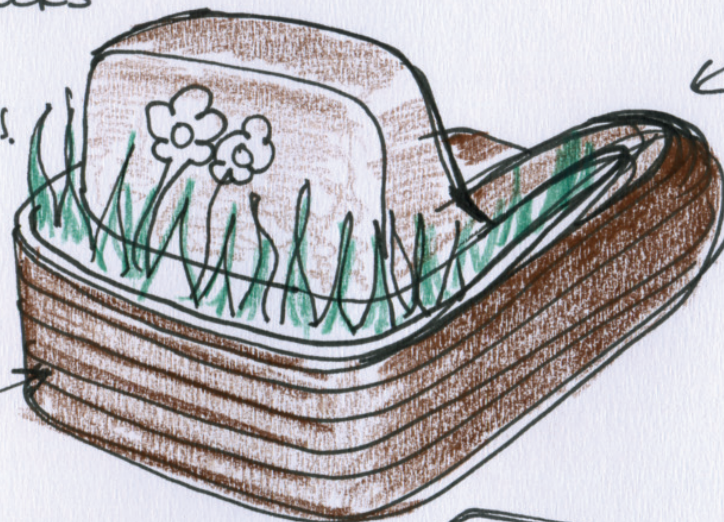

PANCAKE  
LIKE ROCK  
CONSTRUCTION  
"LAYERS"

STRIKING TO  
GRAB THE MEDIA'S  
ATTENTION?



WITH VACUUM  
INSULATION

CHILLY BIN  
REINTERPRETED

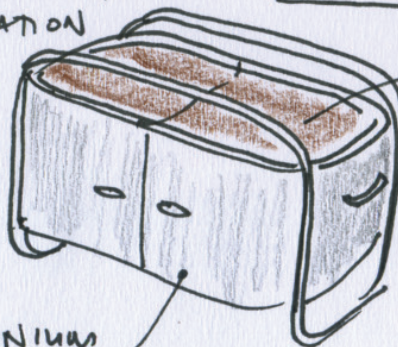

ALUMINIUM  
CLADDING  
WICKER

BAMBOO

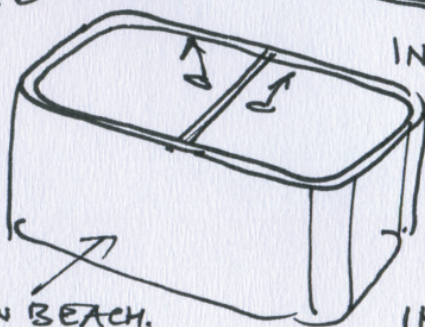

ON BEACH.

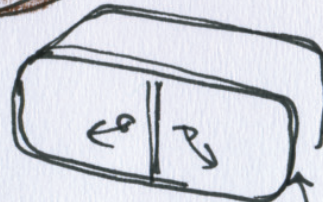

IN KITCHEN

WALL HANGING LIVING  
HERB RACK →  
ANALOGY OF A PAINTING/  
FRAME?

DUAL PURPOSE → PLATE  
IN HOME STORAGE AND  
ON HOLIDAY. STORAGE

© JASON KLENNER 9.12.2009

# "WELL INSULATED" OUTDOOR CHAIR - MAKING THE MOST OF SUMMER.

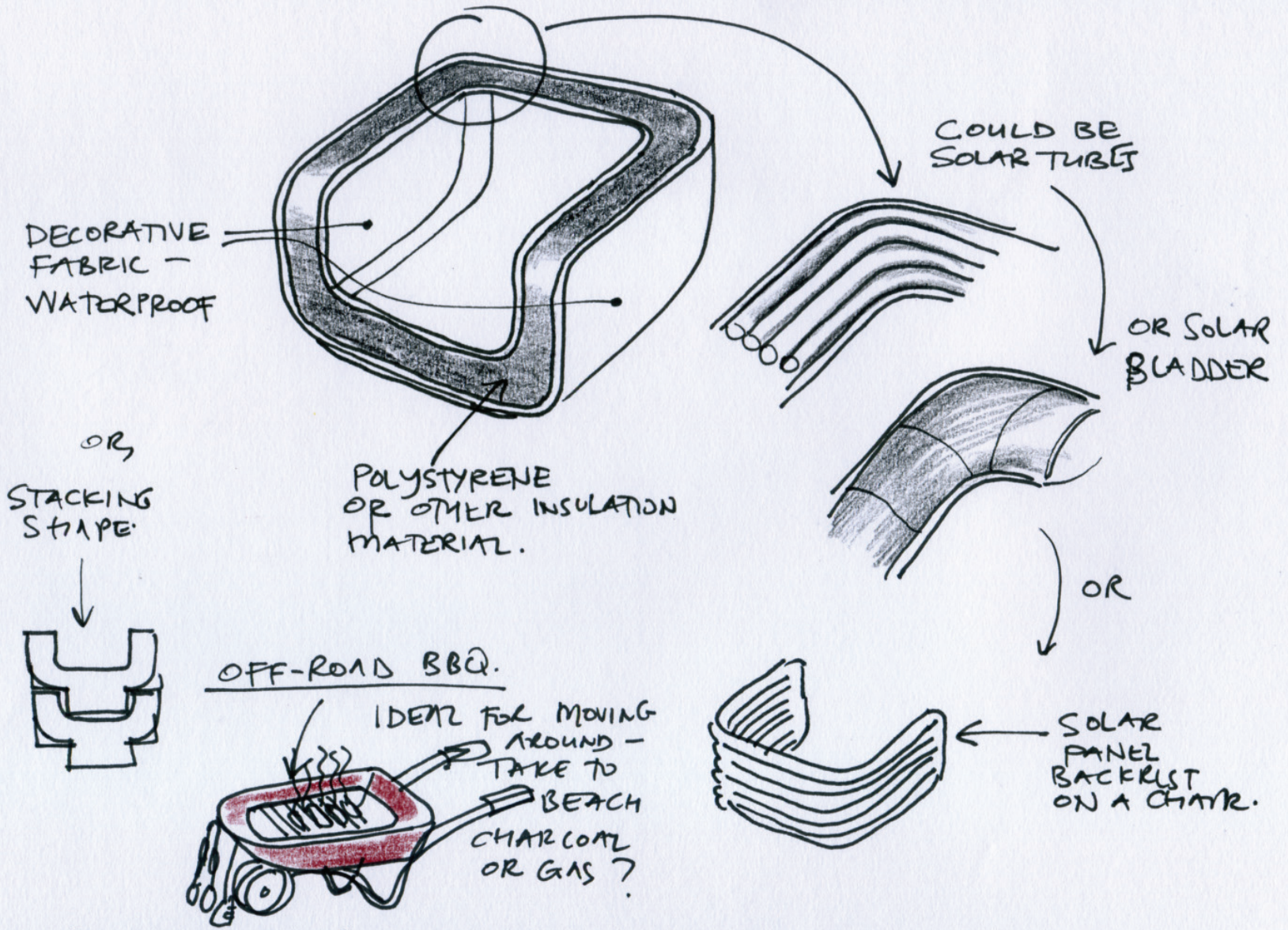

© JASON KUENNER 9.12.2009

# "OUTDOOR ARMCHAIR"

## INFLATE CHAIR WITH EXTERNAL STRUCTURE (OUTDOOR CHAIR)

BIG SIZE/  
THICK PADDING  
RESEMBLES  
AN INDOOR  
LOUNGE  
CHAIR.

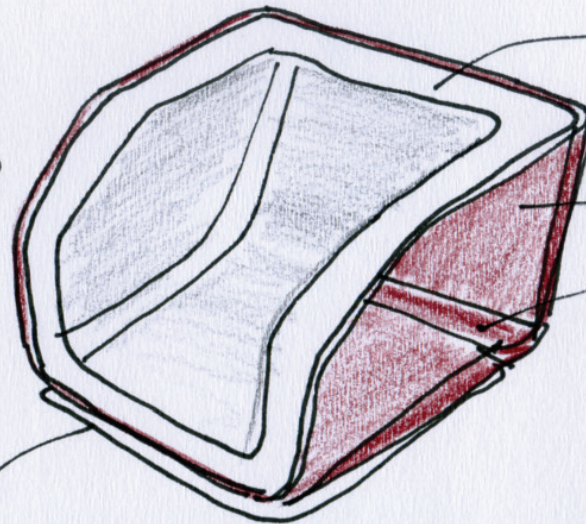

INFLATABLE FABRIC

RIGID STRUCTURE

WICKER?  
ALUMINIUM?

FLEXIBLE CREASE LINES

STRUCTURAL  
BASE: ALLOWS SWIVEL

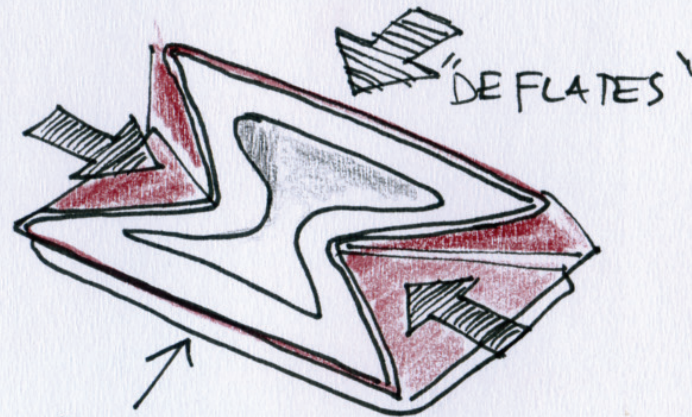

FLAT PACKS  
FOR SHIPPING/STORAGE

TWO SEATER/  
COUCH TOO?

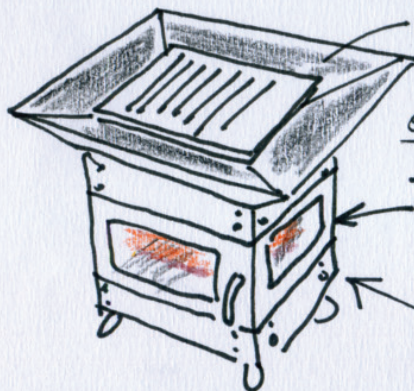

SPLASH GUARD

OUTDOOR WOODBURNER/  
BBQ/BRAZIER.

4 SIDED WINDOWS

SHEET METAL CONSTRUCTION -  
FLAT PACK/LASER CUT

© JASON KLENNER 9.12.2009

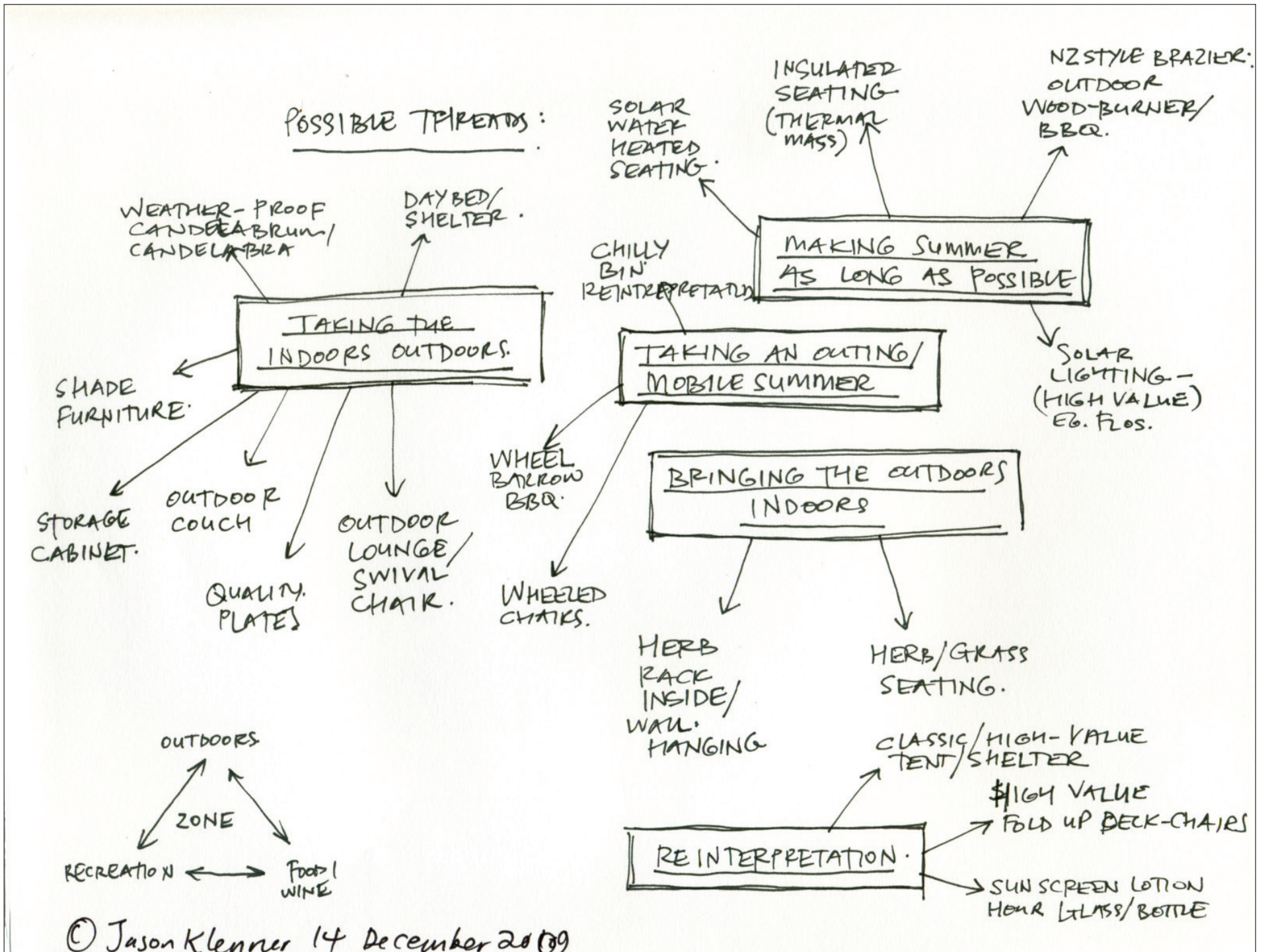

© Jason Klenner 14 December 2009

Jasper Morrison

- 1986 - setup office in London
- 1987 - designed Reuters news centre installation - included in The documenta & exhibition in Kassel in 1987

designed for aram + scp, PSB, Cappellini

Philippe Starck

- (untrained)
- worked with Carden
- gained recognition in 1980s by designing furniture for President Mitterrand.

moved into designing for Italian computers

Marc Newson (sculpture, jewellery design)

Lockheed Lounge in Sydney.

Japan - Teruo Kurosaki (design entrepreneur)

Milan Furniture Fair  
Cappellini, Flos.

Ron Arad (Architect)

Known for area between art and design.  
Co-founded One-off Ltd.  
Rover Chair established a reputation.

Well tempered chair 1986

Career History

Ross Lovegrove

1980s Frog design in Paris  
Knoll International big break

mixed with great intellects  
Sottsass, Sapper.

started visiting Nimes and became involved in the Atelier de Nimes

gained endorsement from Starck

1986 returned to London.

Tom Dixon

(Untrained designer)

1980s created a range of welded salvage furniture (Creative Salvage Collective)  
commissions + exhibitions

Milan furniture fair

Cappellini 1985 's' chair into production

kleiner 15. december 2009

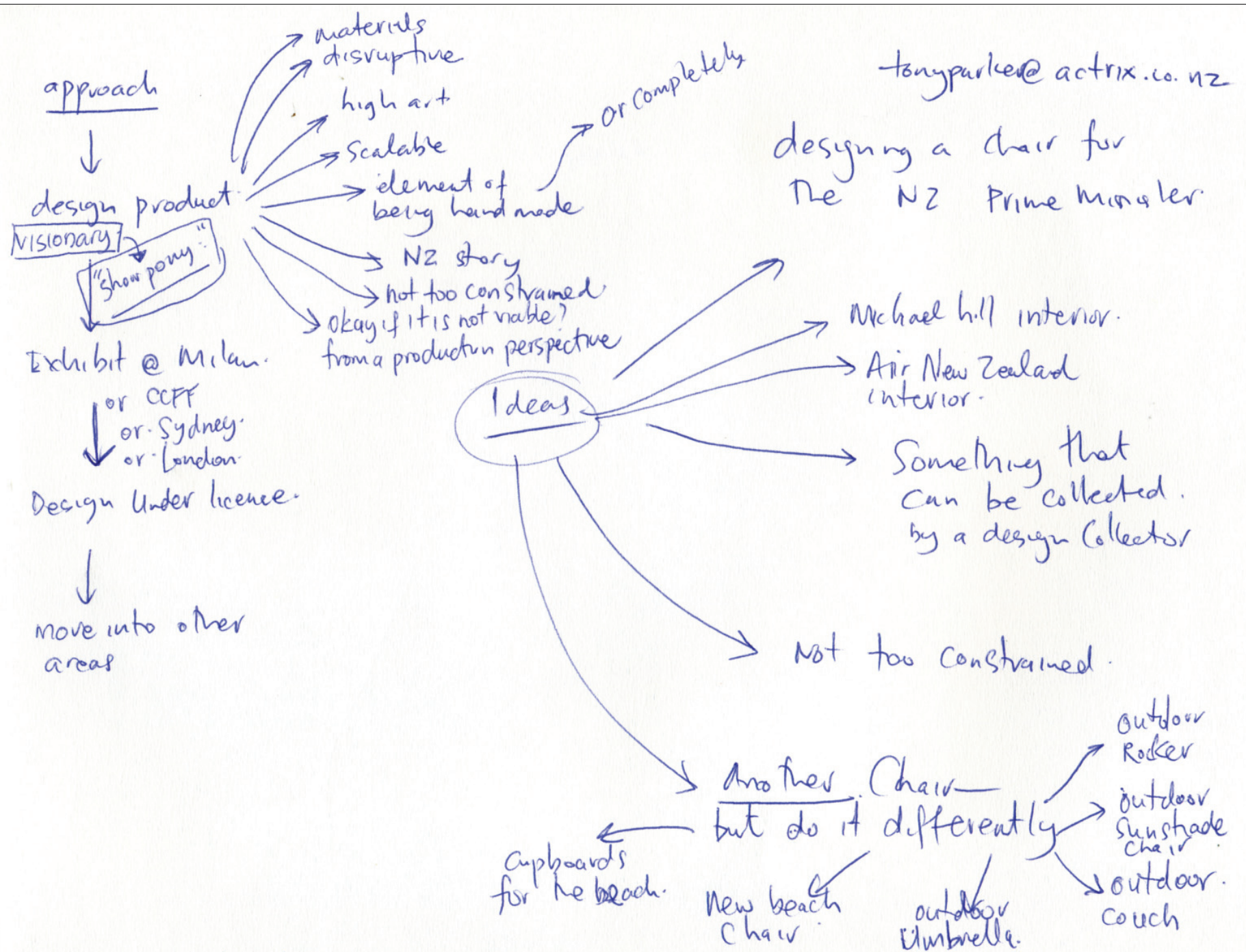

© Klenner 15 December 2009

Agenda

1. Dates for 2010
2. Current Status. - research - still summarising  
- Started sketching.
3. → Looking for work in Wellington.

avant garde work

Poetic with Practical.

approach from a number of artistic perspective



orientation that counts

chard light BBQ.

orientation that is Sculpture art First

clever  
idea-

and.

Sculpture

---

that it is Jason → ~~thing~~  
What is Jason about?

Ross Lovegrove Amara

---

Sculptural art

Julian Brown

---

how you design:

object age with time

---

see how people interact with their products

---

See how peoples habits are changing →

© Jason Klenner 15 December 2009

Outdoor  
chaise lounge

approach →  
Sculpture

approach →  
material

approach  
shade

approach  
telling a story

He. Irvine  
Installation used  
to work for Sotheby's

Tony Durnin  
@ RCA.

Tell a  
Story through  
objects  
"Trubridge"

Fine artist talk about installations.

→ Producing a place - installation  
that is Eutopia. →

a total experience → forced  
to look at something differently

© Jason Klenner 15 December 2009

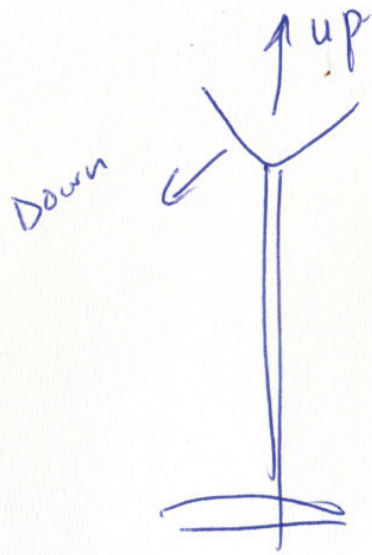

what I try to  
say through the work

Must spin my wheels.

Super ellipse

Beautiful and clever.

"Through experimentation"

Find out what  
I value  
- what I am about

© Jason Klenner 15 December 2004

Golden Rule = prototype

externalise ideas

explore → make mistakes → make again

test = test of an artist

March = prototype

take risk \$.

They won't laugh at me.

Contemporary art and Sculpture.

"Sculpture Magazine"

what do I want to say → what is my story — passionate about something → "Jokes"

© Jason Klemmer 15 December 2009

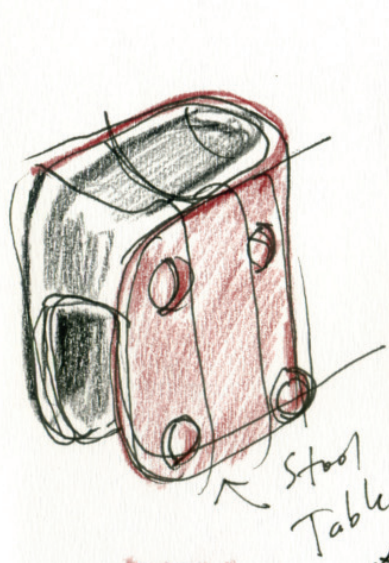

Stool  
Table

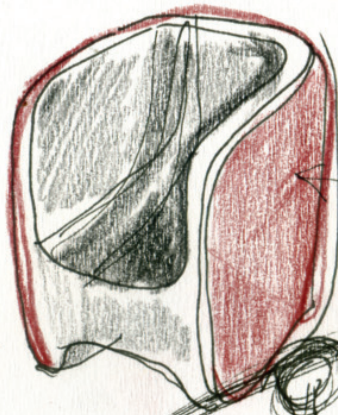

Seat/lounger



What types of furniture are there?

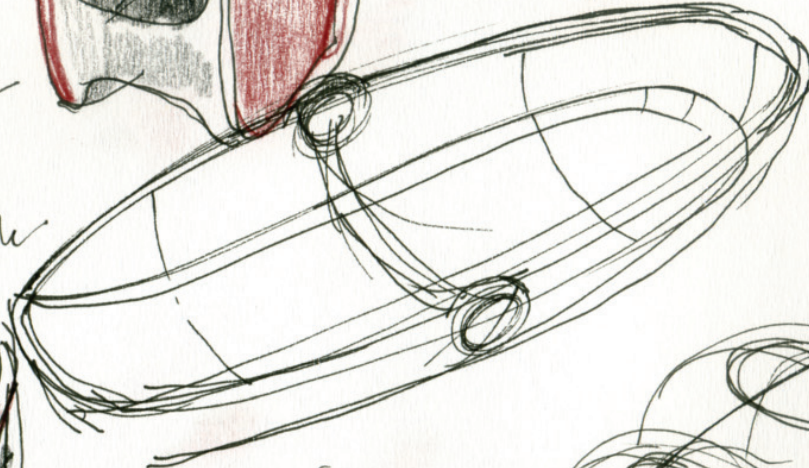
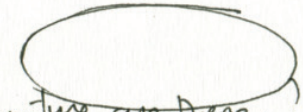

What is the idea?

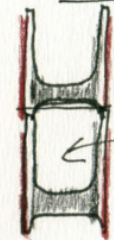

shelf

Stacking

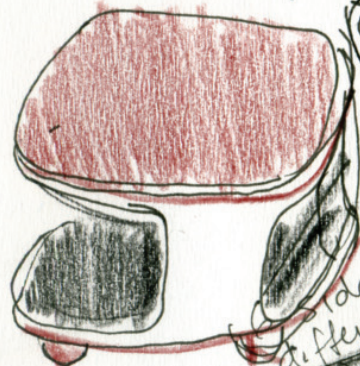
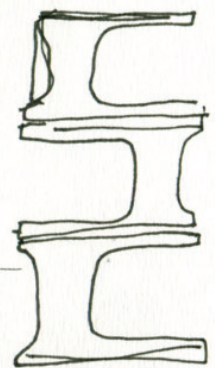

folded outdoor chair  
different seat heights etc

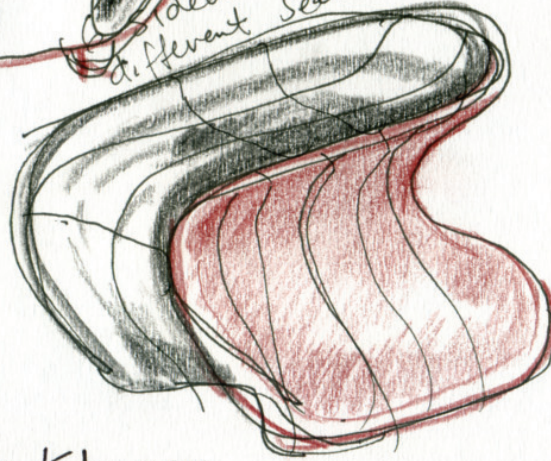

Taking  
inspiration  
from other things  
- architecture food  
- bontology  
- rockets

© Jason Klennor  
5 January 2010

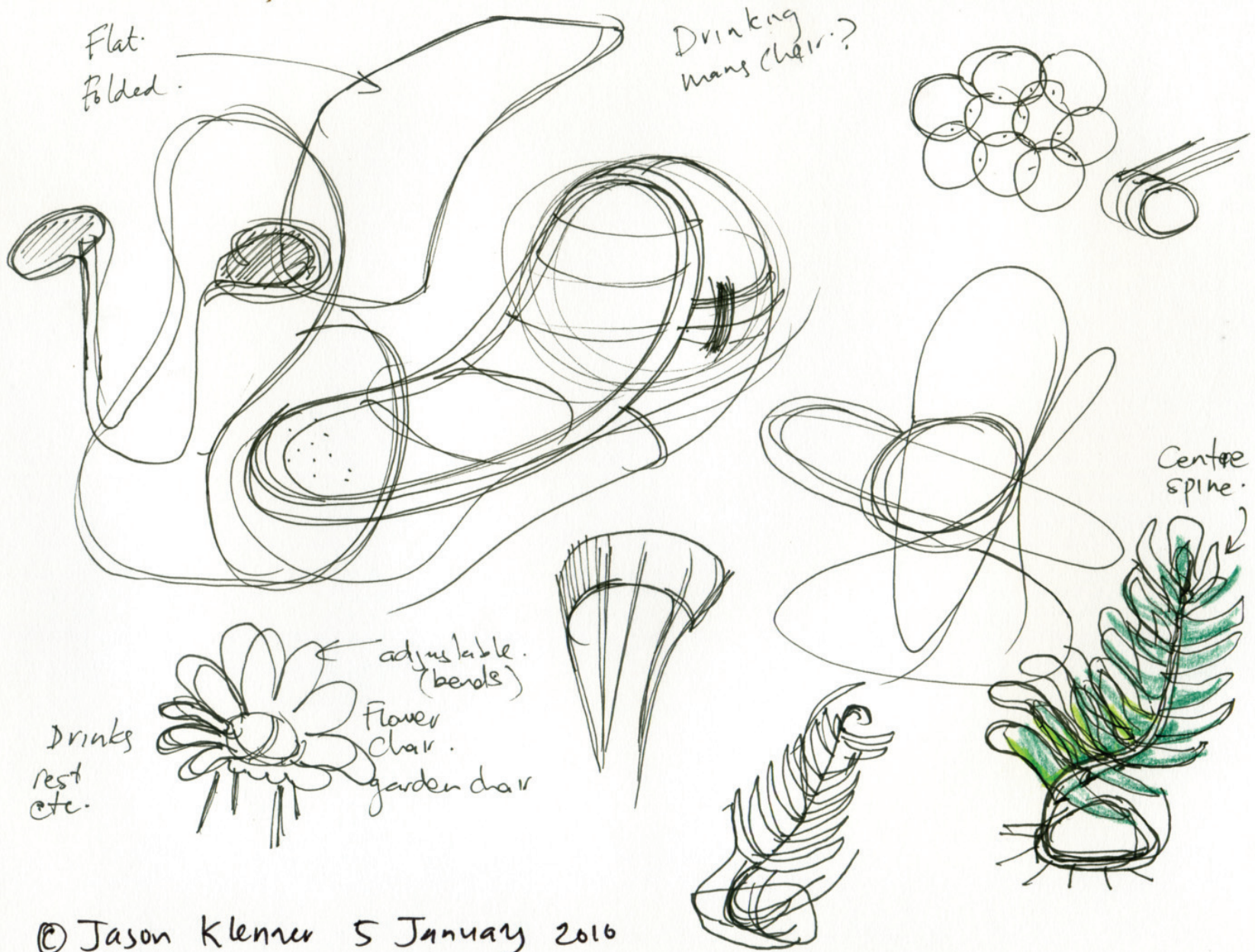

© Jason Klenner 5 January 2016

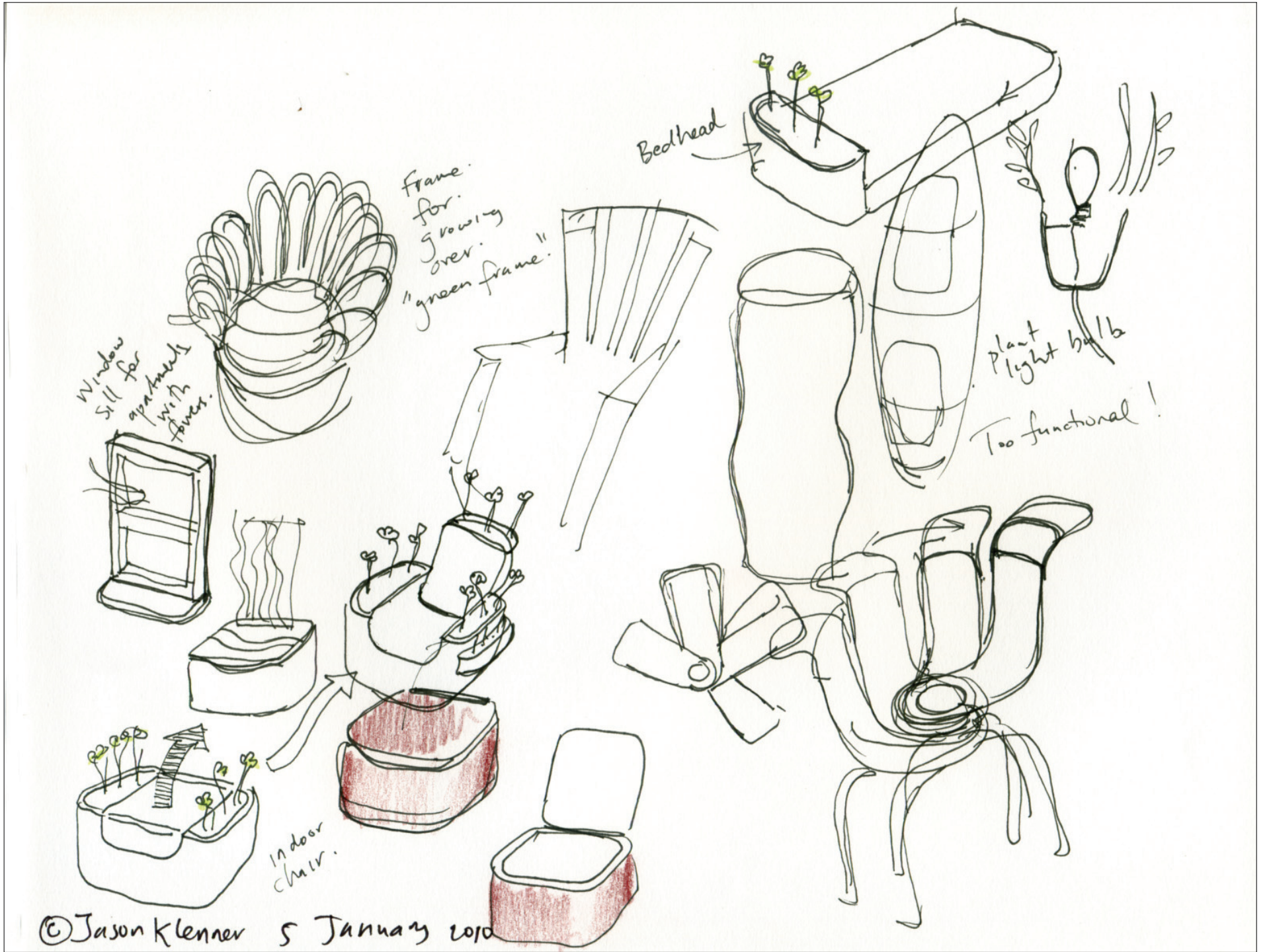

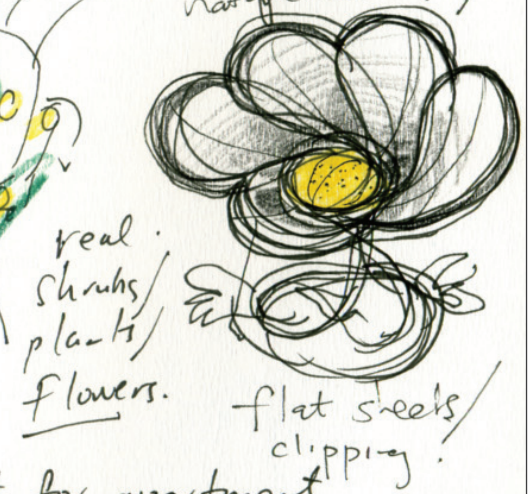
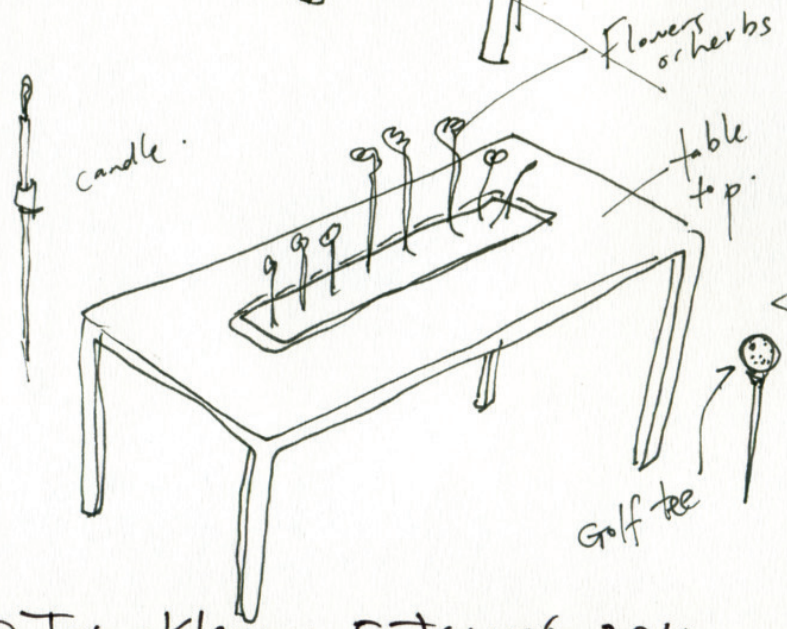
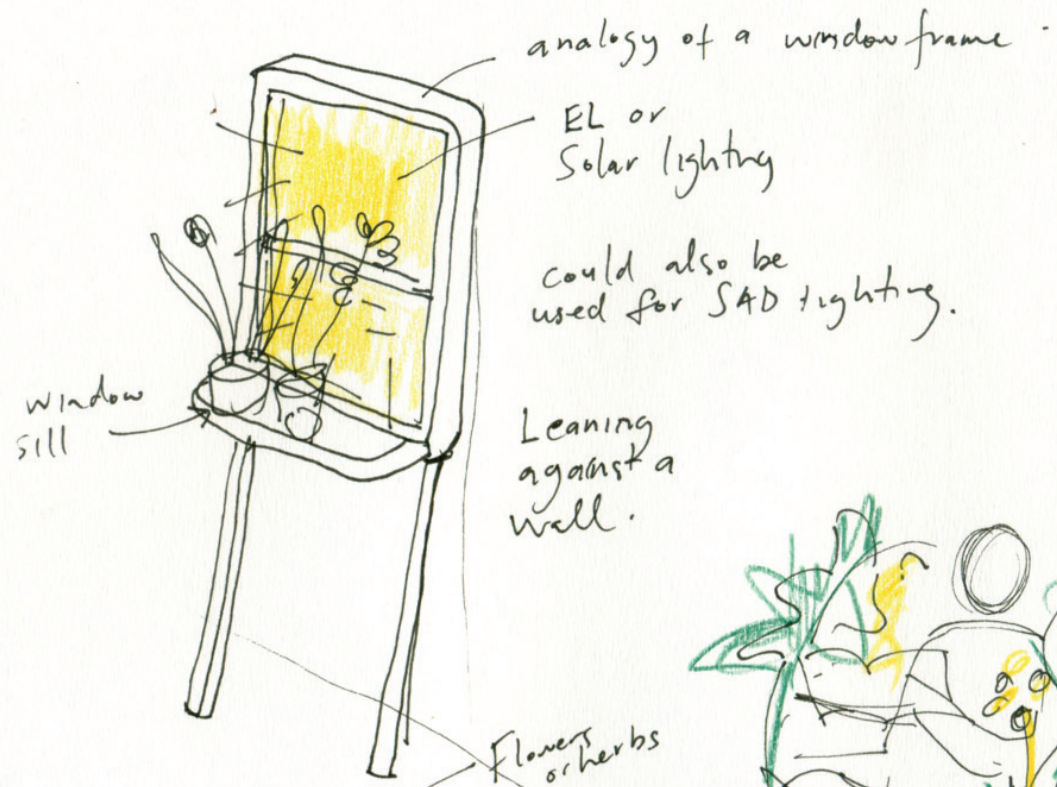

great for apartment dwellers - indoor / outdoor zones.

relaxing to be amongst the beauty of nature.

© Jason Klenner 5 January 2010

Beach / architecture / birds / boat houses

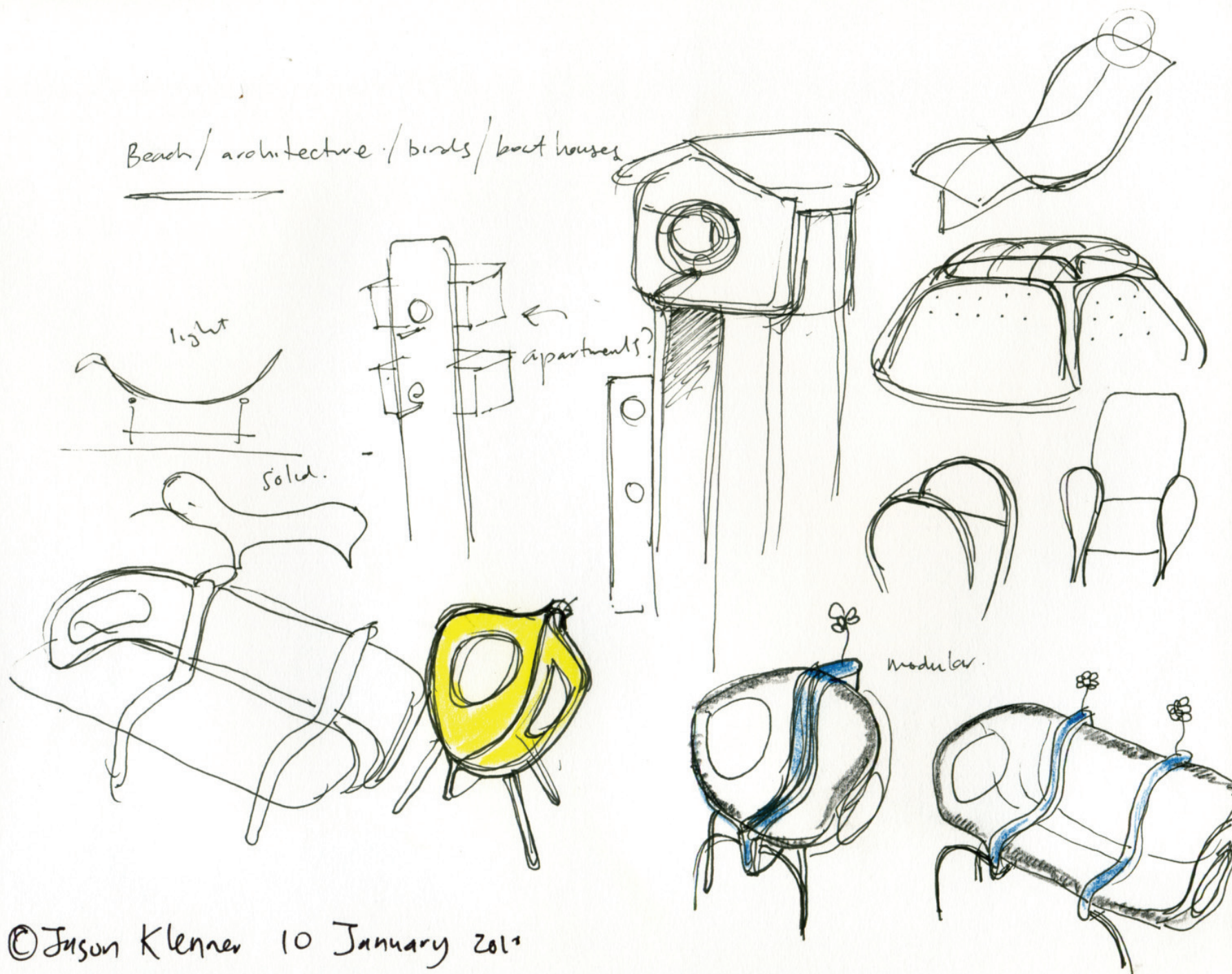

© Jason Klenner 10 January 2013

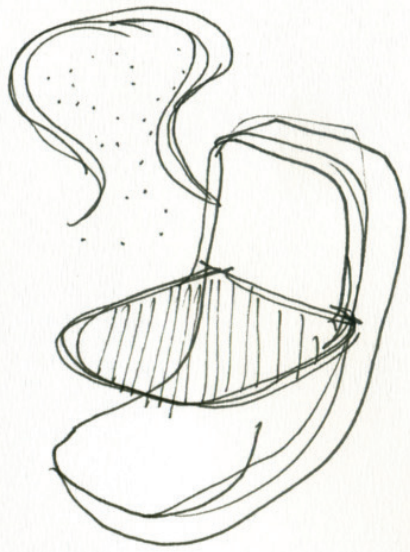
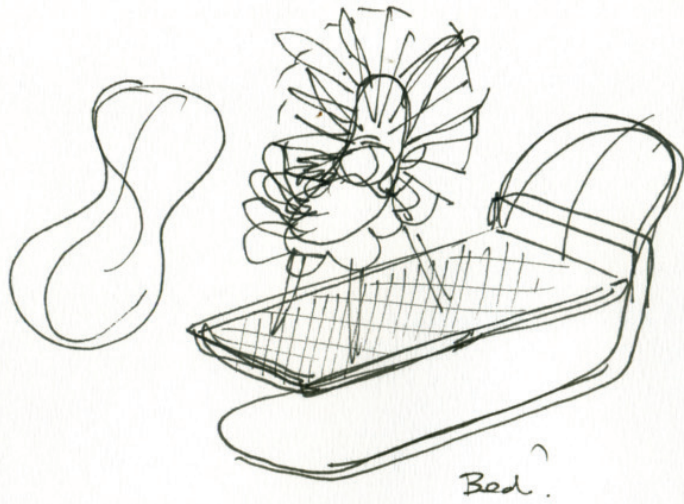

○  
Newson = organic wholesome  
Trubridge = ?

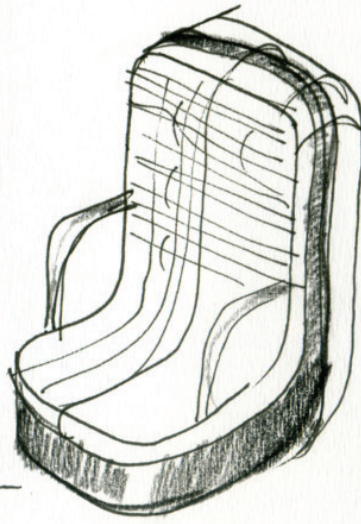
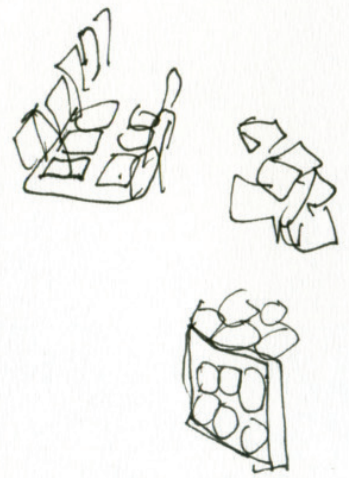
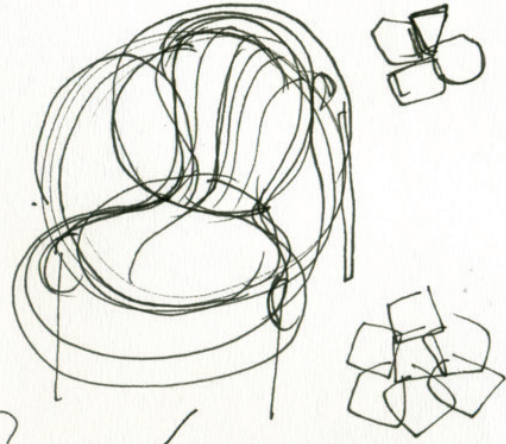

○  
Too functional?

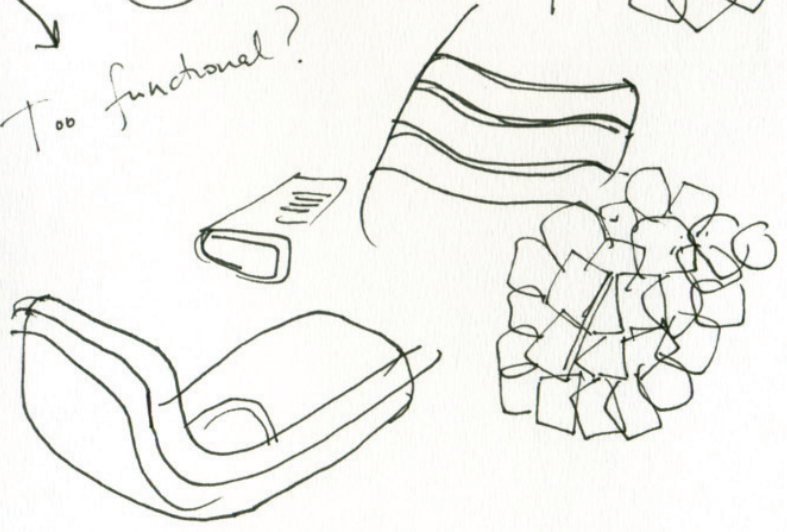

© Jason Klenner 10 January 2010

"

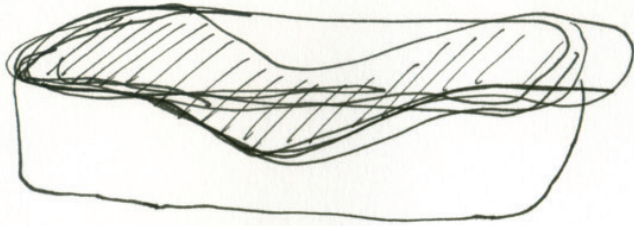

- outdoor lounge
- indoor chair/lounger
- indoor planters

"

" poetic with practical "

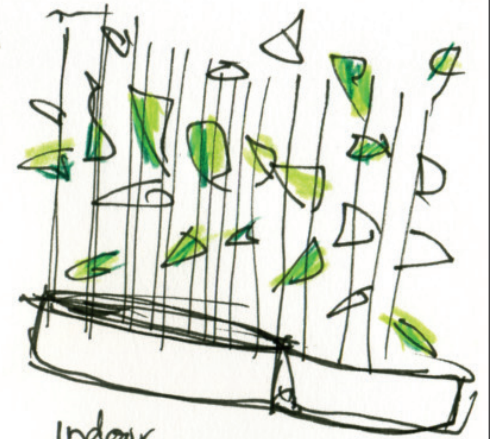

What am I about

indoor growing partitions

1. pragmatic
2. interested in seeing how things are used
3. interested with experimentation.
- 4.

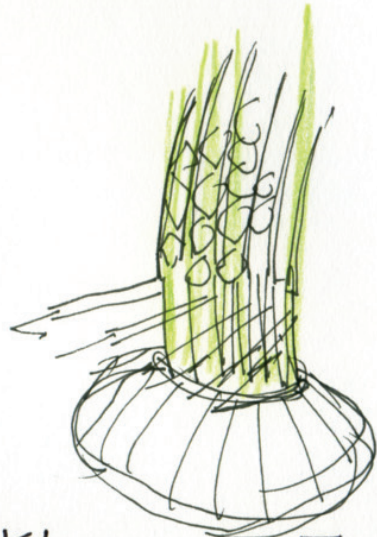

Sculpture with design?



Vase / planter boxes

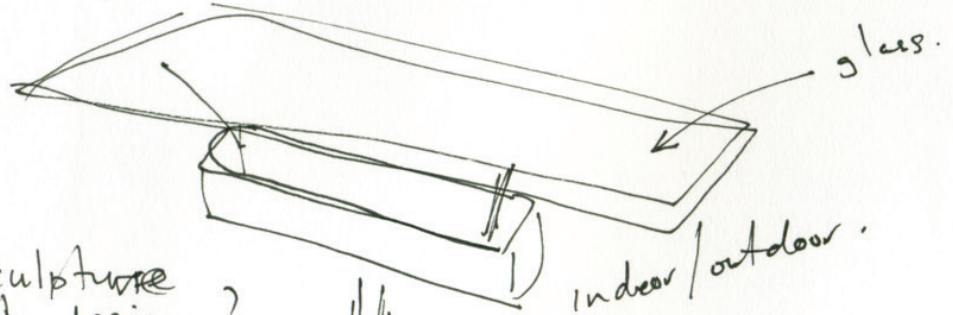

© Jason Klenner 10 January 2010

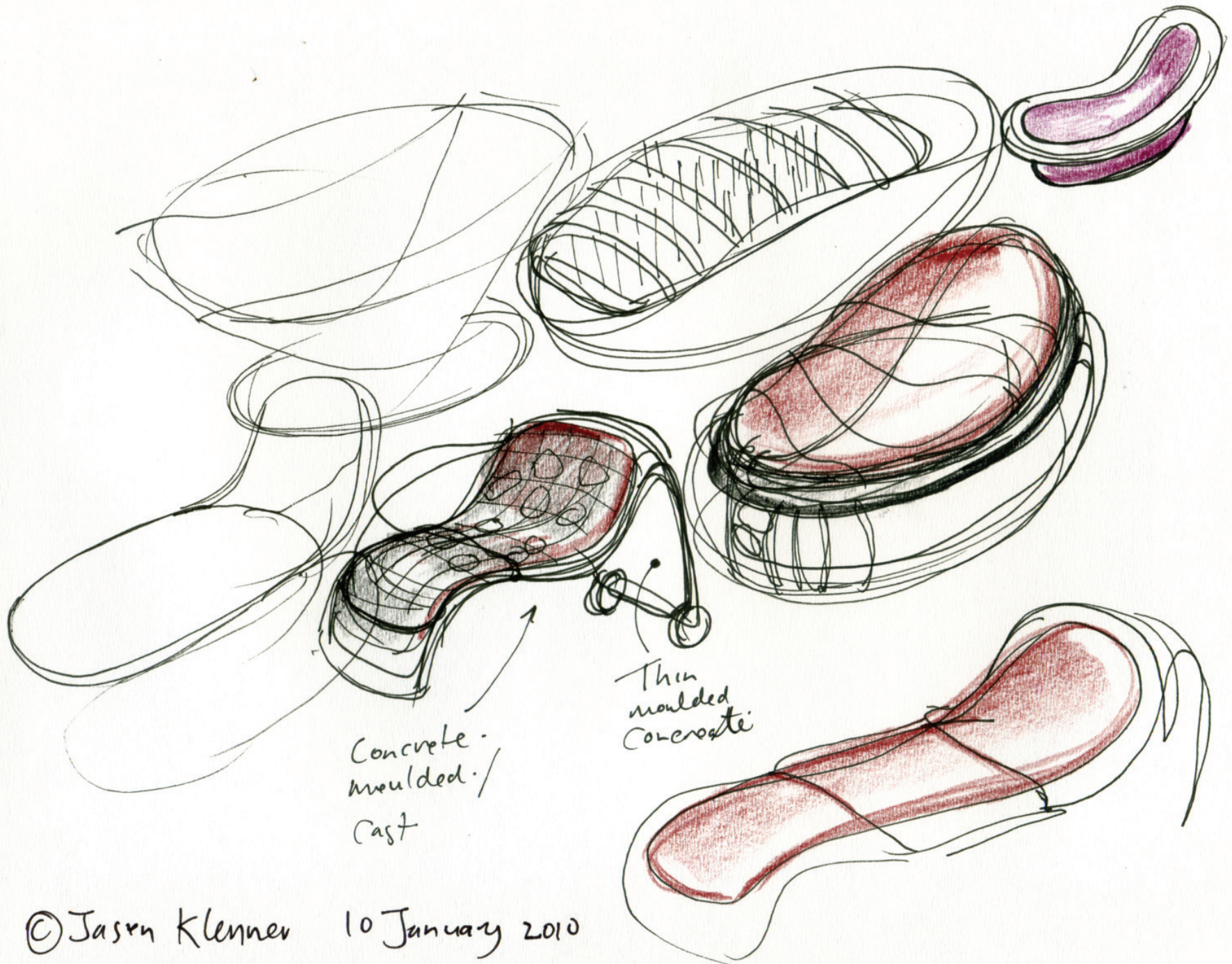

Concrete-moulded/cast

Thin moulded concrete

© Jason Klenner 10 January 2010

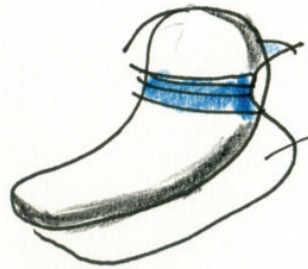

wrap.

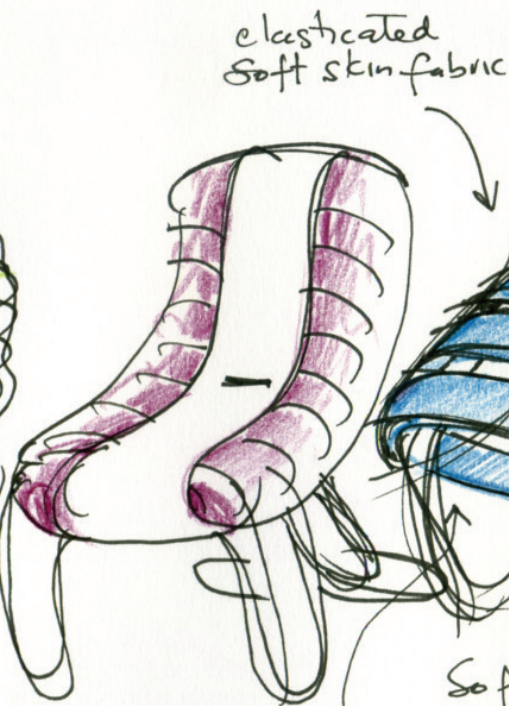

elasticated soft skin fabric

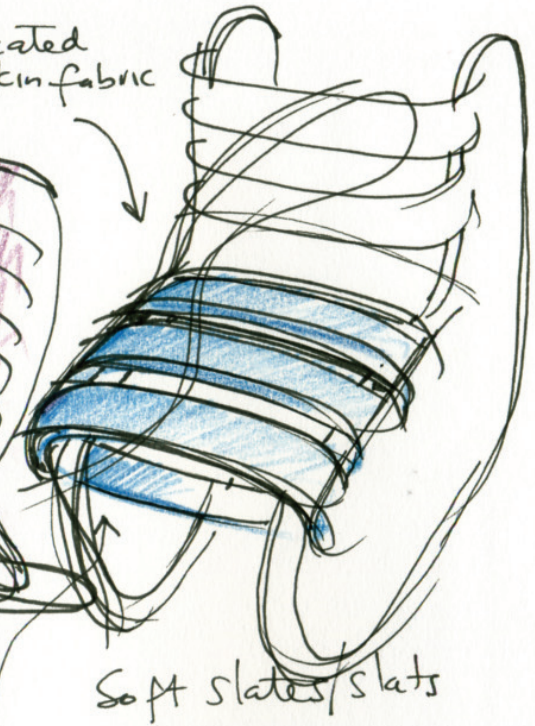

soft slates/slats

nice popping under detail.

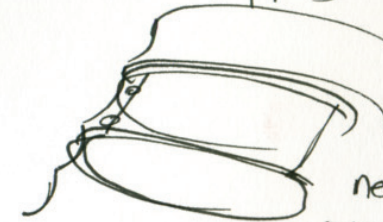
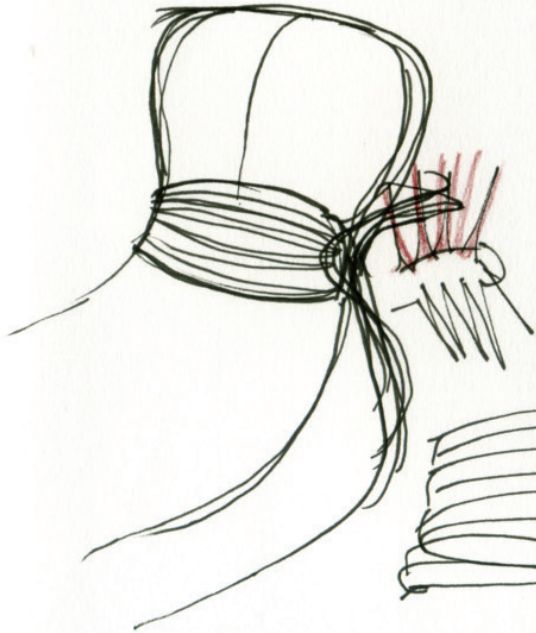

Summer '65 revisited.

new Zealand. pre commercialism style.

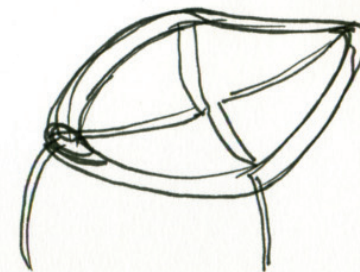

© Jason Klenner 10 January 2010



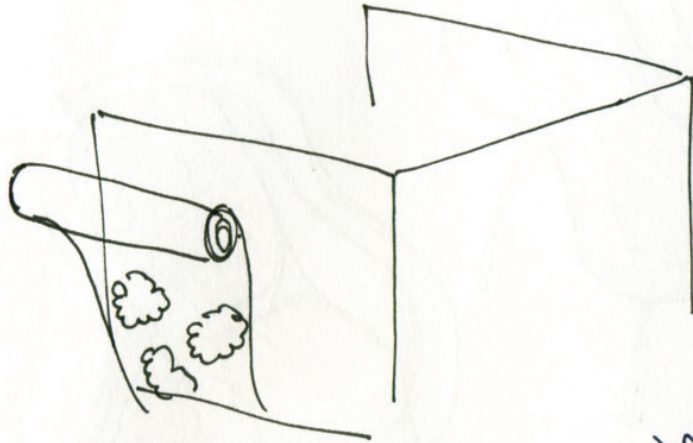

wallpaper  
chair.  
to match your  
interior.

"furniture  
for life"  
lasting your lifetime.

analogy  
from consumer  
electronics -  
front fascia/  
chip-on etc.

©Jason Klenner 14 January 2010

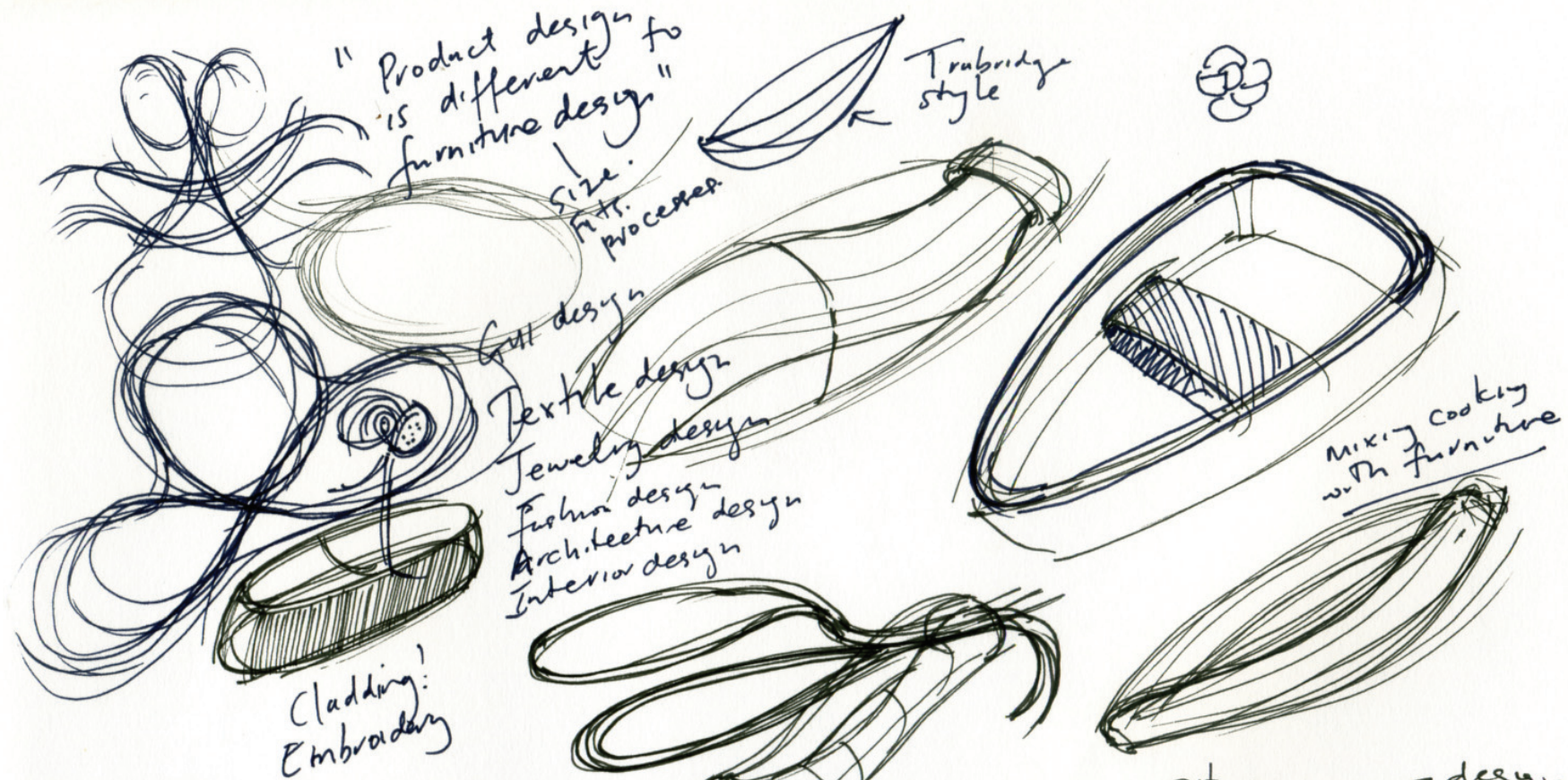

Consumer electronics  
appliances

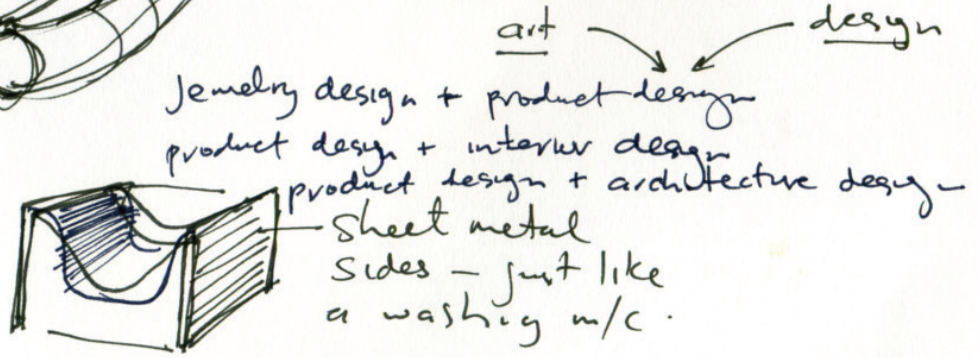

- mixing cooking with furniture
- mixing furniture with interior/space

© Jason Klenner

14 January 2012

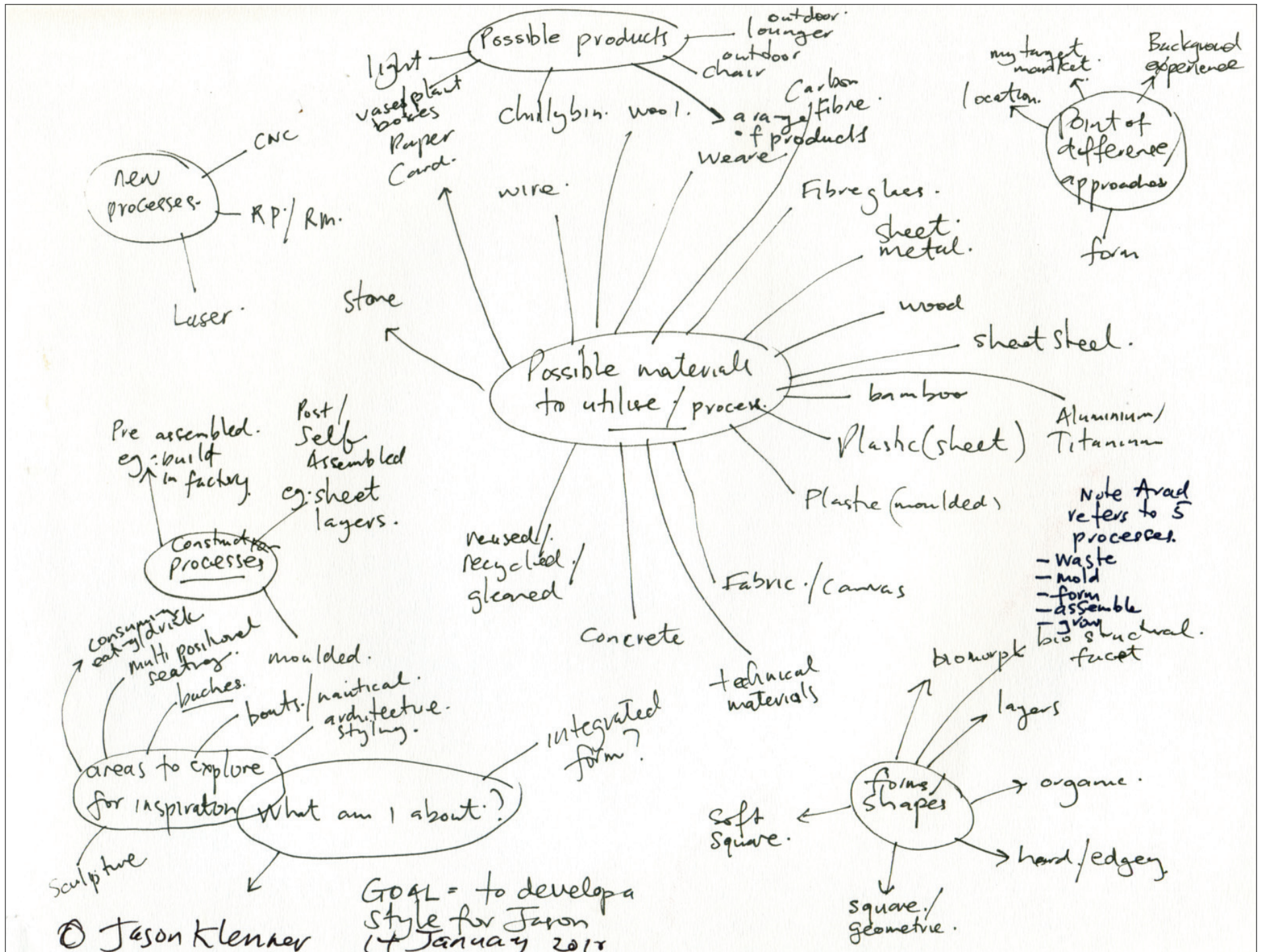

approach 1.

'Thinnest Chair'  
Carbon Fibre to  
create a chair  
of unbelievable  
thinness.

approach 10  
clip on panels

approach 4

NZ Summer of 65'  
revisited.  
precommercialisation

approach 7

pure sculpture.

approach 2

Taking the outdoors  
indoors.  
green/flower  
friendly furniture.

approach 11

approach 5

Taking inspiration  
from Kiwi beaches.  
The 'bach lounge'

approach 8

Complete minimalism.  
→ materials used  
for their natural  
properties

approach 3

Plant/flower  
metaphor.

approach 6

The drinking  
person's chair.  
chair with areas for  
drinks./food/books.

approach 9

DIY chair.  
- well paper covering?  
- paint the m?

© Jason Kenner 17 January 2010

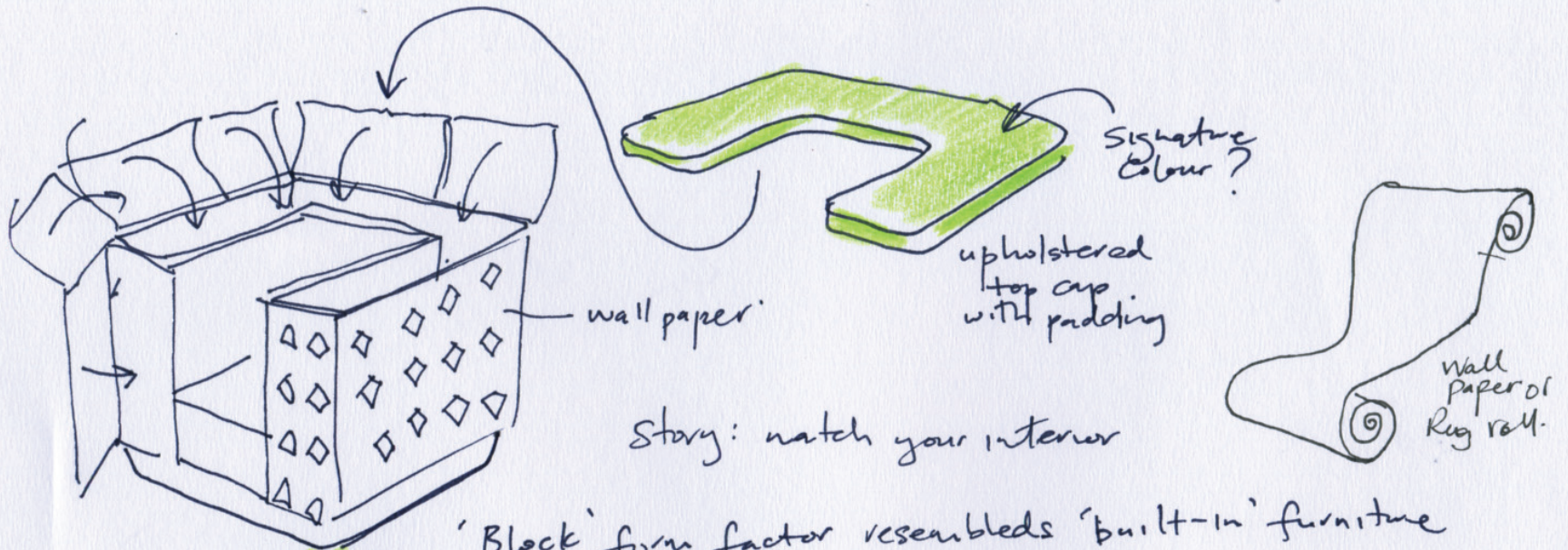

Story: match your interior

'Block' form factor resembles 'built-in' furniture  
Such as shelving → even doors?

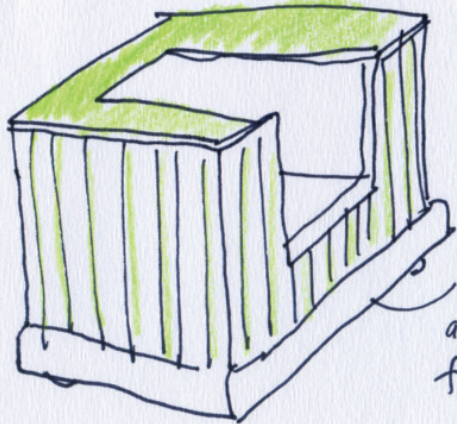

skirting boards?  
another metaphor  
from interiors.

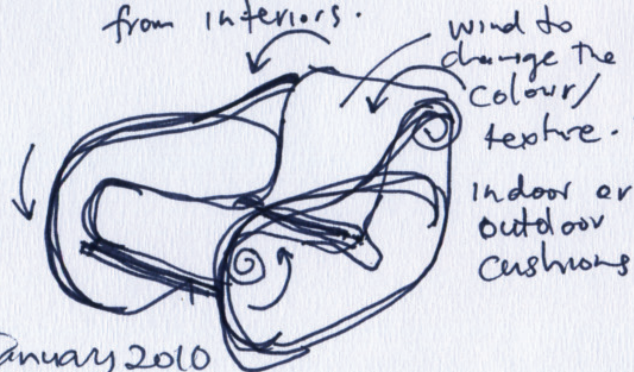

would to change the  
colour/  
texture.

indoor or  
outdoor  
cushions

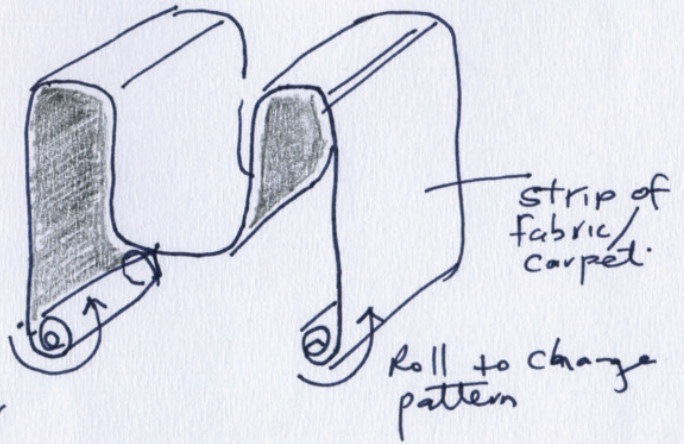

© Jason Klenner 19 January 2010

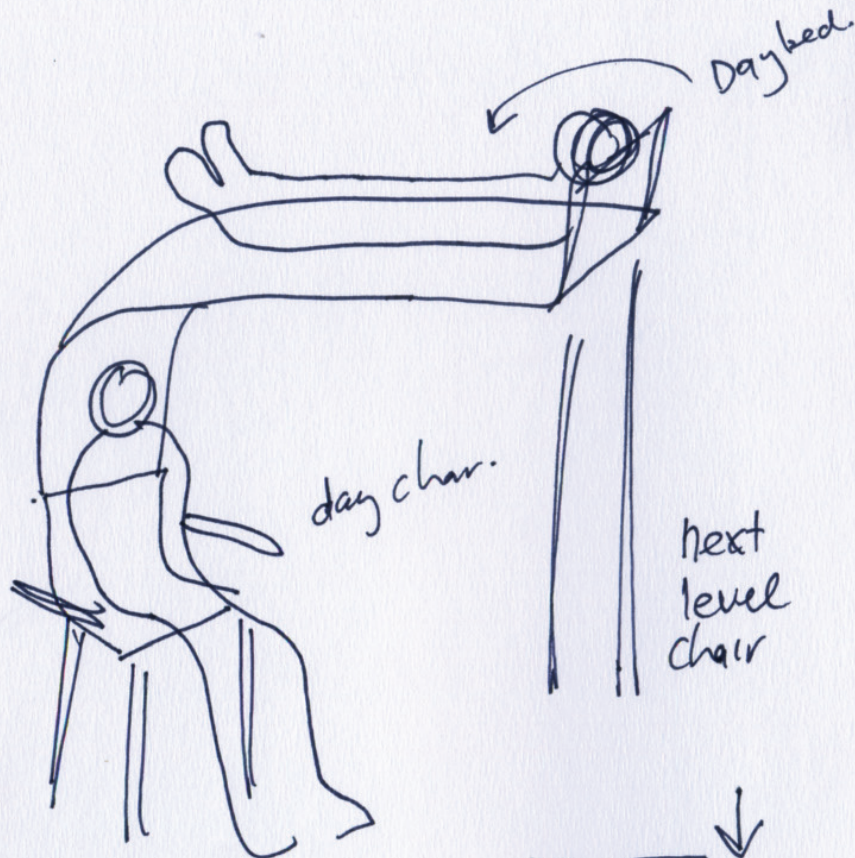

funk style.

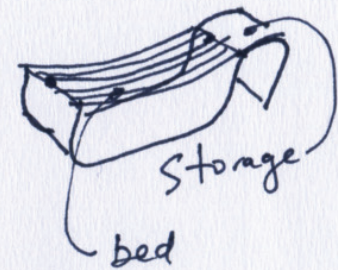

112 music chair

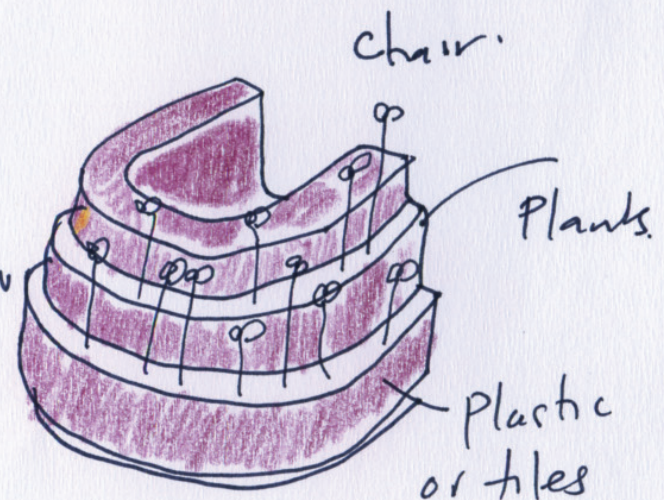
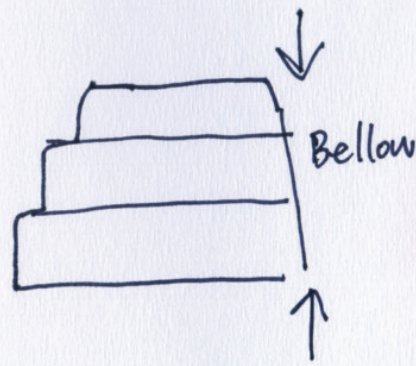
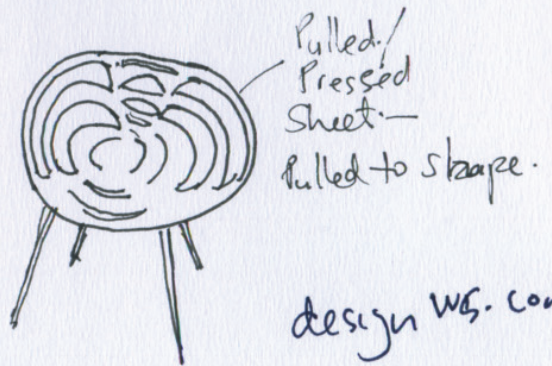

design WS.com

© Jason Klemmer 19 January 2010

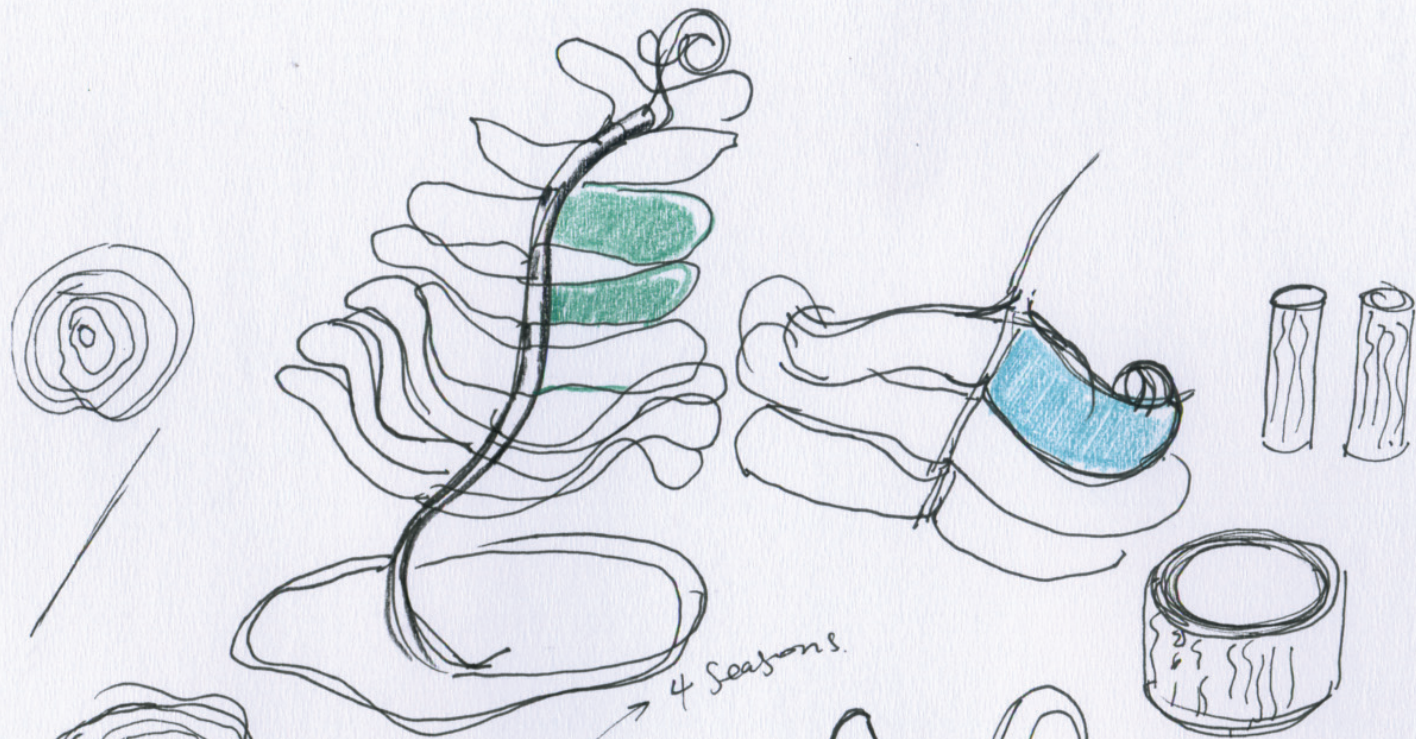

4 seasons.



outdoor chair.

clear weaving with green tint

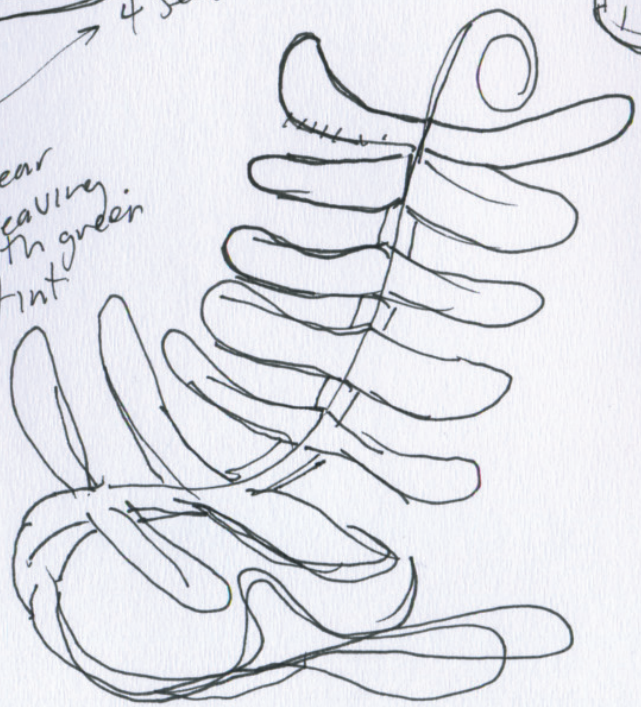

clip/snap in ribs.

©Jason Klemer 19 January 2010

Point of difference could be. — new combinations of materials

Concrete. Carpet. Stone. Wood. Sand. glass.

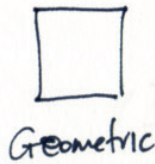

Geometric



facet



organic.



organe Structural. lovegrove



Soft block morrison fukasawa. Newson.

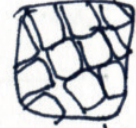

geometric structural

trubridge



Trubridge = wood. Steel?? = who.

Arad. = Sculpture. = design language.  
 Newson = Contemporary Style + vision = design language / approach  
 Lovegrove = Nature + Vision = design language / approach



Trubridge = Timber + CNC processing = design language.

Morrison = Simplicity of form = design language  
 reduction

Arad = Angles facets = design language



Fukasawa = Simplicity of form = design language.

more art orientated style

Aiad.

Form: Sculpture / Sculptural (emotional not rational)

Iterations / Themes / studies.

experimental (-story, -processes, -forms)

uses steel -> metals

more commercial style

newson

uses colour.

Form: refined / slick (emotive not rational)

works across a variety of media.

signature forms / integrated forms throughout ranges

Developed into a very contemporary style, but distinctive. (minimal)

Lovegrove

more commercial style

form (signature) 'organic essentialism' natural world, reinterpreted into futuristic forms.

structural forms.

subdued colour.

expressive form.

Simple but structural.

more craft orientated style

Trubridge

use of wood / timber

turns 2d into 3d

uses CNC technology

makes his own products.

Quality of hand-crafted objects.

signature.

Mechano/Torro. (building blocks)

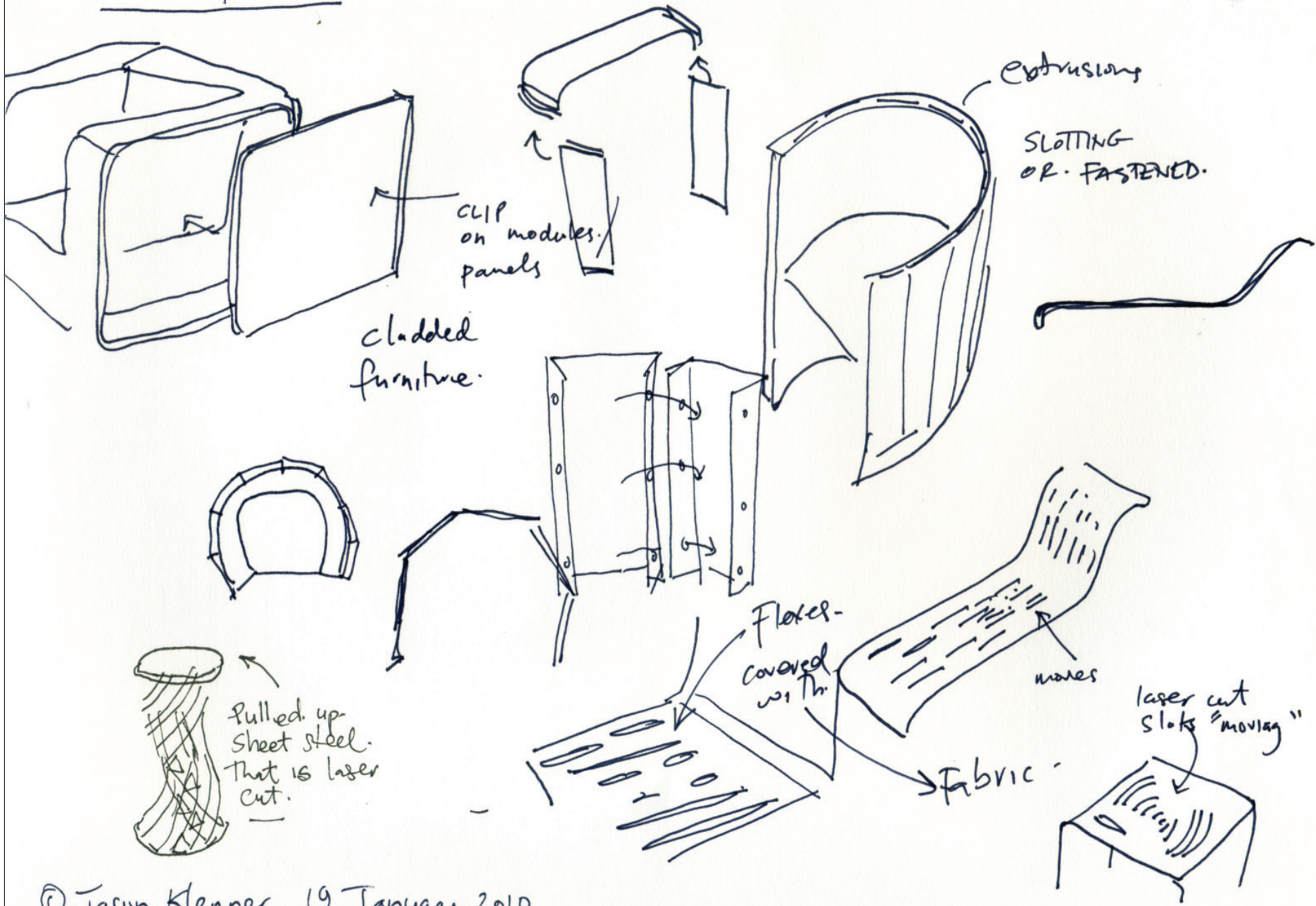

© Jason Klenner 19 January 2010

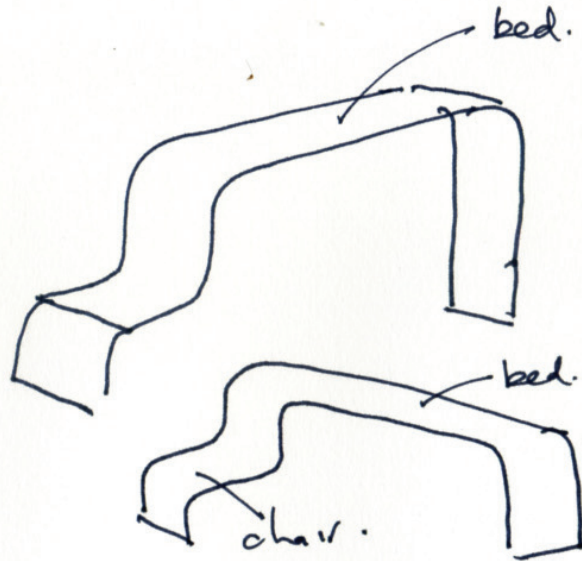

## Research (summary findings)

1. Summarise findings
2. add depth to findings.
3. Proof read. - interview summary sheets  
- interview condensed sheets  
✓ research findings.

4. Summary of Trubridge, Arad, Lovgrove; Neeson, Morrison.

- key phases of life
- timeframe
- point of difference
- Background.

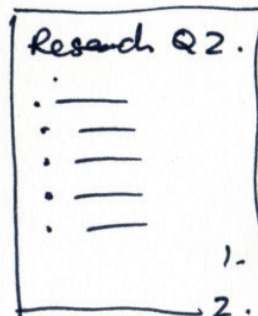

- 1.
- 2.
- 3.

## Synthesis

- Design objectives → reinvent. (eg)
- Design Brief → design a chair (eg)
- Requirements → exhibit @ Milan (eg)

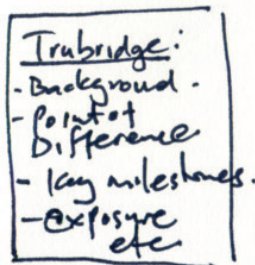

© Jason Klenner 19 January 2010

→ Design Signature <sup>furniture</sup> product → exhibit @ milan → gain exposure.

Apply this approach to another area?

Grow the ~~from~~ other industries like the furniture industry in Italy.

ANGLE = OUTDOOR PRODUCTS. (FURNITURE)

Criteria

must be a product that is considered emotive.... (not a commodity!)

express "Jason"

gain international exposure at a relevant fair/show.

Poetic and Practical

(combining a clever idea with sculpture)

reflect/be associated with NZ. renowned with 92

Tell a story

incorporate an element of craft. hand-made

Arad = Sculpture with Art/design = Furniture + Architecture

Newson = Strong style with Art/design. = all products

Lovegrove = Organic + Future = products.

Trubridge = Timber + CNC = products.

Furniture → owned by lots of celebrity designers

Home goods → owned by less designers?

→ Apply the lessons learned to a new product category → not furniture?

19 January 2010 © Jason Klenner

We must acknowledge the established process for gaining exposure as a designer:

furniture → exhibit @ Milan → commission → further commissions.

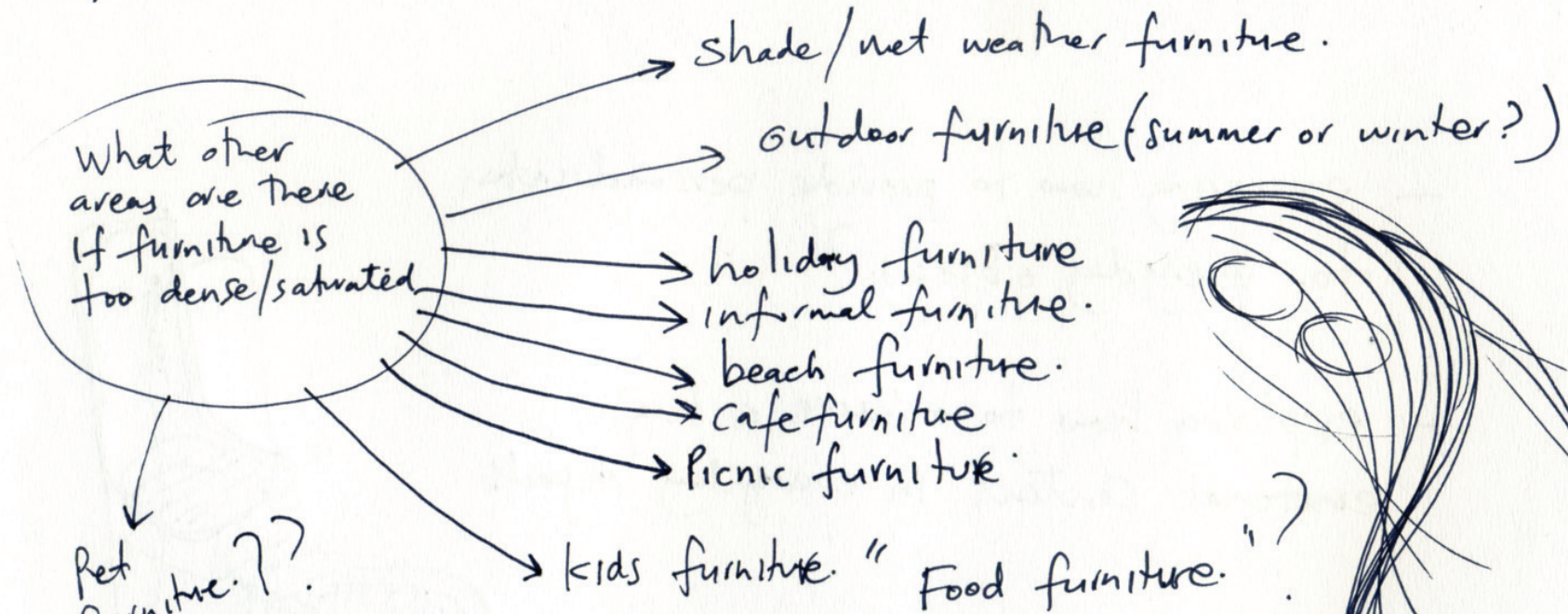

Pet furniture.??

chairs  
Seats  
loungers

tables  
Stools.



19 January 2010 © Jason Klepper

- exploring how to provide personalisation  
to everyday objects?

- exploring how to achieve a high  
emotional content in everyday objects

-

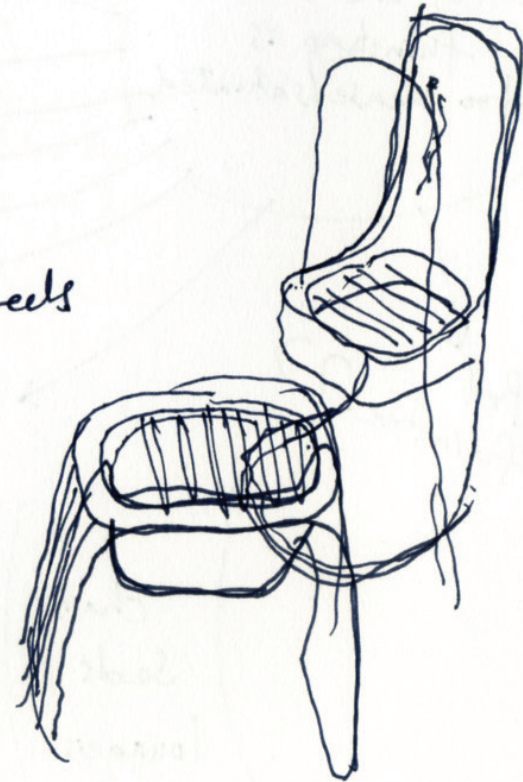
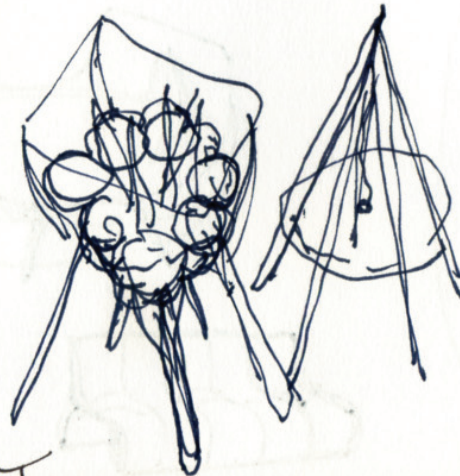

© Jason Klenner 19 January 2010

Picnic - towels  
BBC → classic kiwi icon.

Furniture.

Wool.  
appliances — washer  
toaster. etc

Wine — glasses. / stoppers. / racks /  
decanter

food prep. — knives  
— cutlery.  
— plates  
— chopping boards  
— herbs/spices — racks  
— scales.  
— racks

An Invention!!  
Coffee. (handpress ??)

Beer.  
Knick Knacks. — new interpretations. → vases. etc.

Water.  
clocks

Cooking:

what else has a high  
emotional content. →  
what other product categories:  
Personal:  
- Jewellery.  
- watches  
- fashion. / shoes.  
- phones.  
- bicycles.  
- Sunglasses.  
- bags / wallets.  
- pens.  
Shared:  
- furniture

(Evolving a range of something

Simple technology

- > radio
- > clock.
- > both.
- > light / lamp.

• gallery pieces →

creating a series of alternative cookers. or chairs etc

→ transforming low tech into desirable "desirable lowtech"

or. a super simple  
blog.

Gallery Pieces  
for a beach  
picnic.

inspiration  
a "Royal BBQ."

Product  
Story / Approach.  
Visual Idea.  
Show Case / target  
Target Audience

© Jason Klenner 19 January 2010

Transforming <sup>regular</sup> technology into emotive products. → high value:

- radio + form = desirable.
- clock + form = desirable.
- kettle + form = desirable.
- lamp + form = desirable.
- telephone + form = desirable.

lessons learned  
from limited edition  
furniture industry?

↑  
not reinventing myself though?

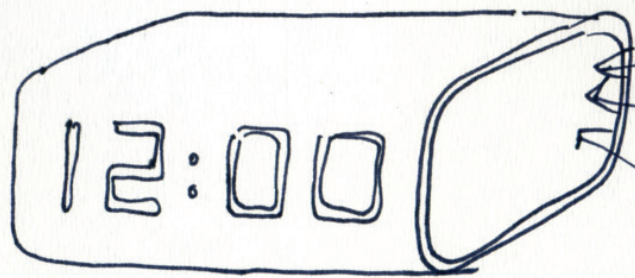

ceramics?  
carbon fibre?  
upholstered? ← or →



- applying:
- > Domesticating appliances
  - > Applying craft to appliances. (craft principles)
  - Moving to emotional products
  - " limited consumption "

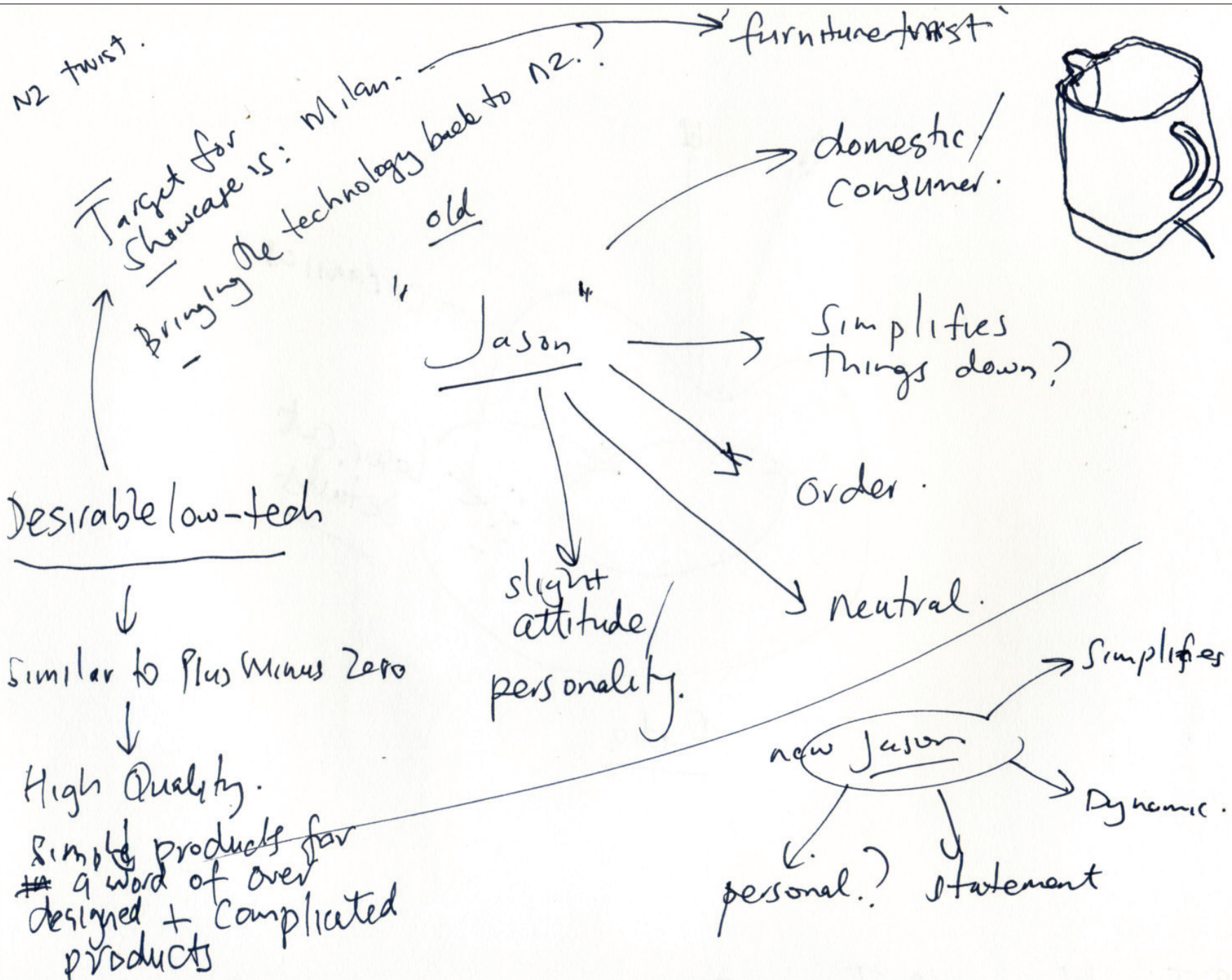

19 January 2010 © Jason Klennor

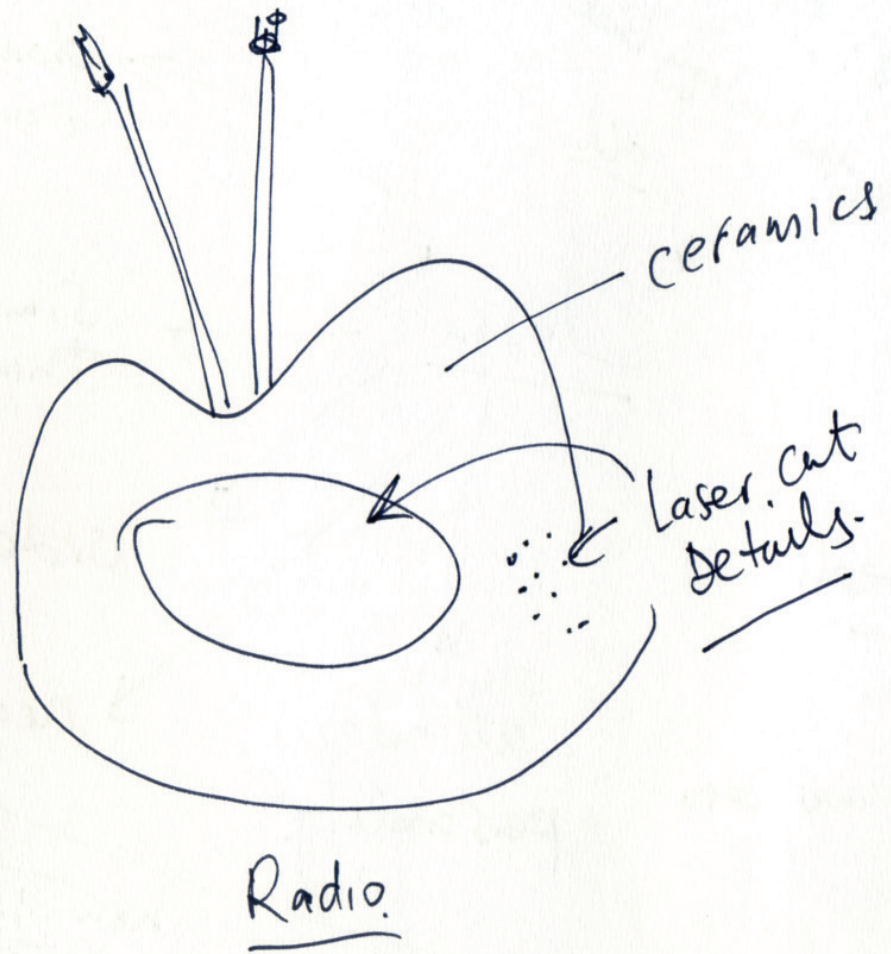

© Jason Klenner 19 January 2010

Reference points:



well tempered chair.



lockheed lounge.



body raft



spring  
In out

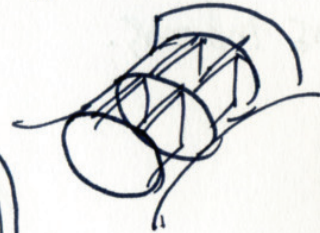

CARPET COVERED FURNITURE.



like leather covered.

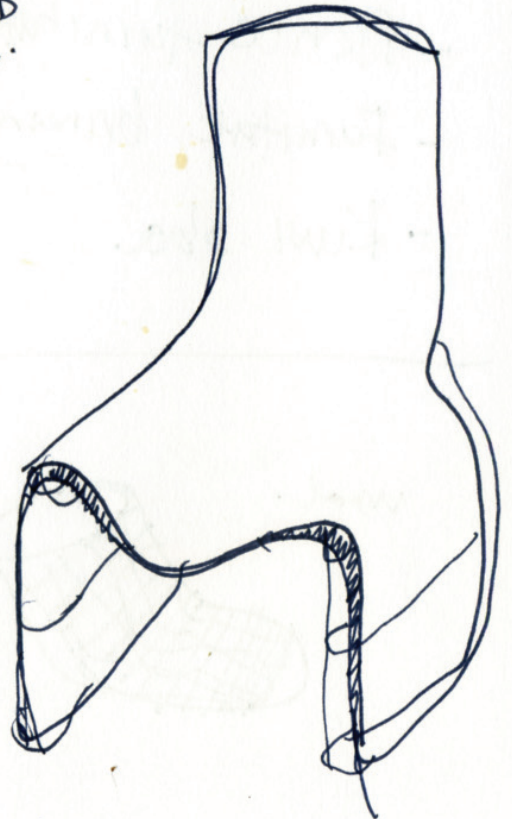

© Jason Klennco 19 January 2010

"Beautiful"

must be beautiful.

Threads.

- desirable low tech
- outdoor furniture (~~indoors outdoors~~)
- picnic furniture.
- furniture bringing the outdoors indoors.
- kiwi bba.

- limited edition
- gallery pieces
- element of hand-craft

wool.

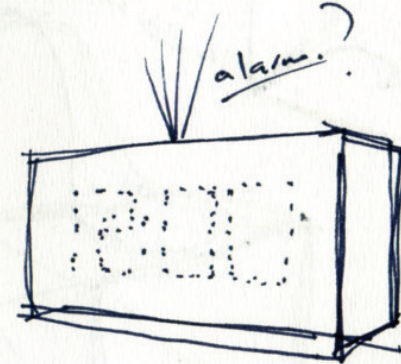
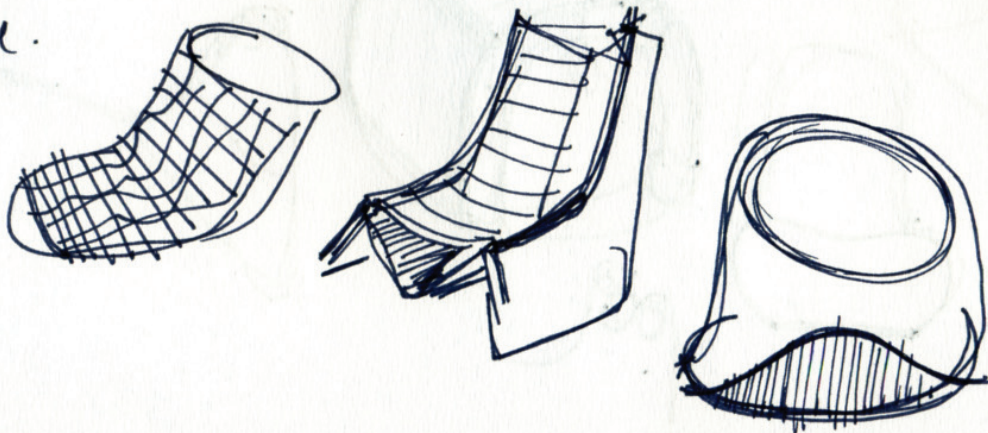

Bluetooth  
a message  
to this unit.

Materials/processes.

- Steel.
- plastic.
- wood.
- Ceramic & glass.
- foam.
- Sheet moulded.
- cut.
- extruded.



sequins.  
covering.



3d carpet?  
wool.  
hanging?



draped cloth

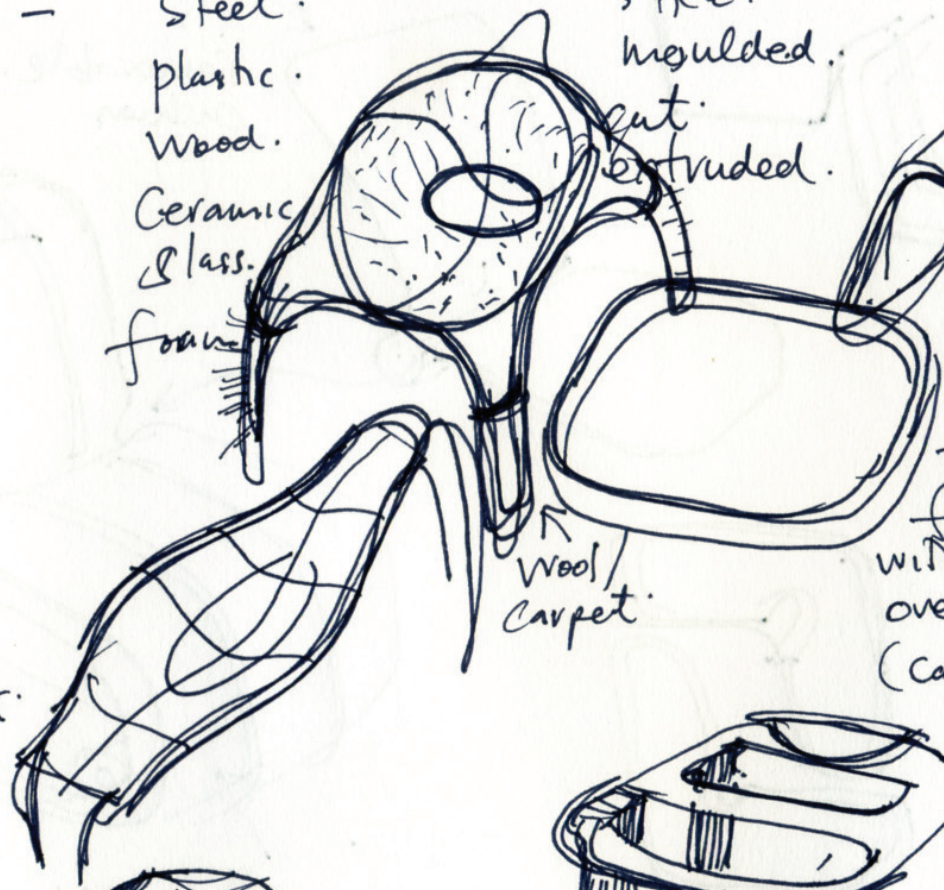

wool/carpent



3d formed structural fabric with wool over the top (carpet)

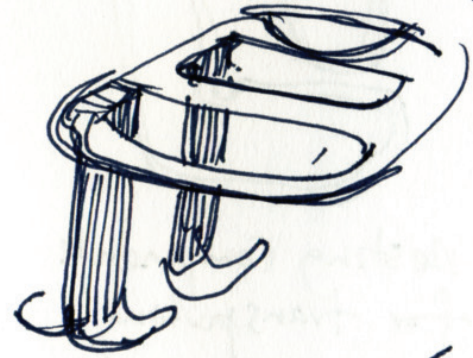

outdoor  
chair.

removable  
cushion

Fabric/  
flap

Roto mouldings

Too heavy?

Nesting components  
for transporting.

Note: Is this material really premium?

© Jason Klenner 20 January 2010

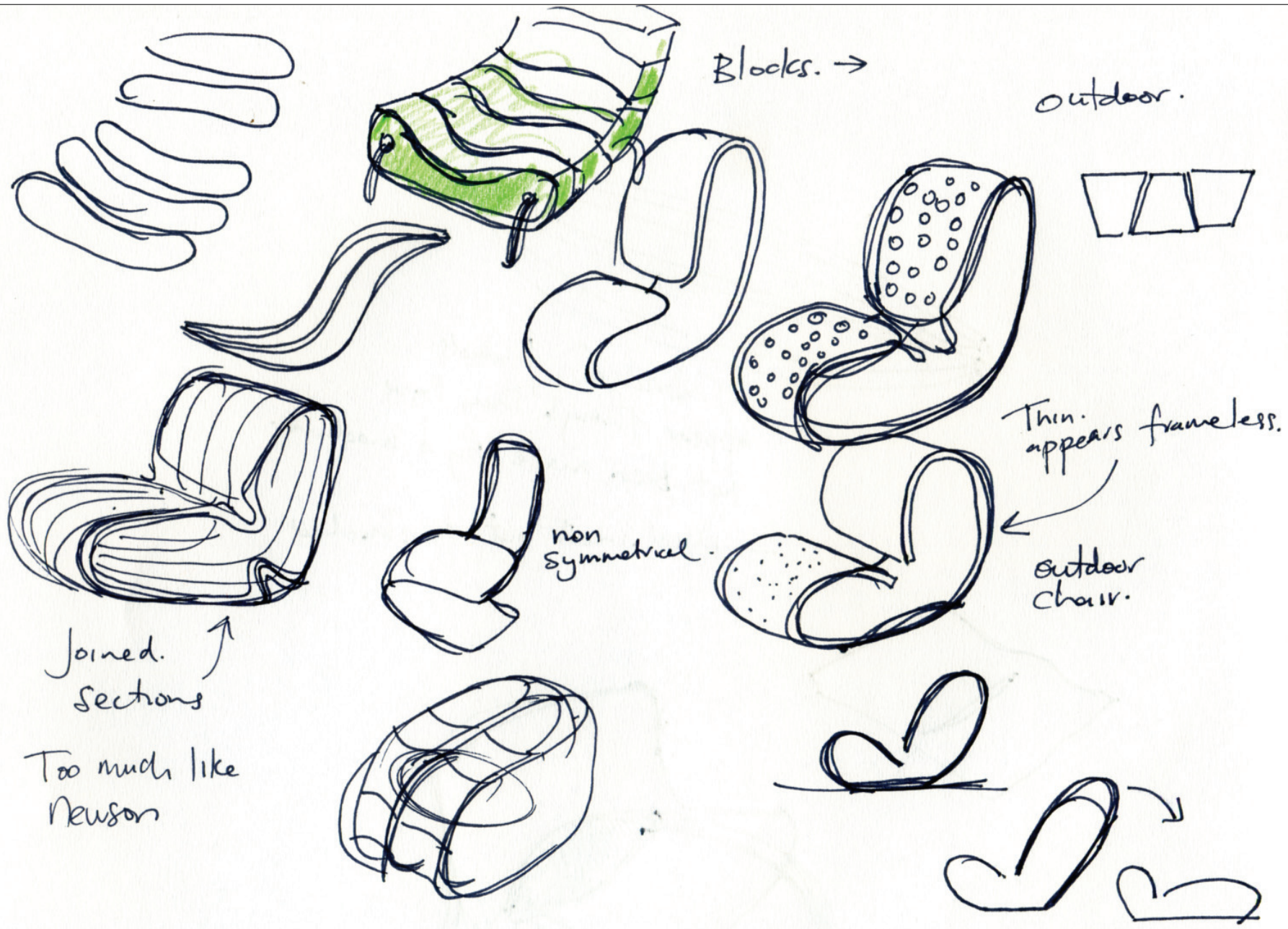

20 January 2010 © Jason Klenner



Trubridge's products  
appear though they have  
not been made by a machine.  
→ machined but constructed.

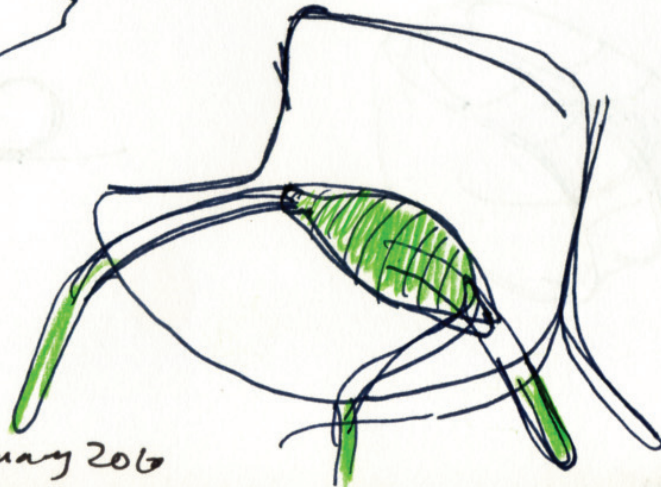
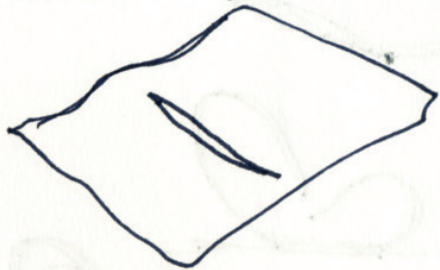

© Jason Klenner 20 January 2016

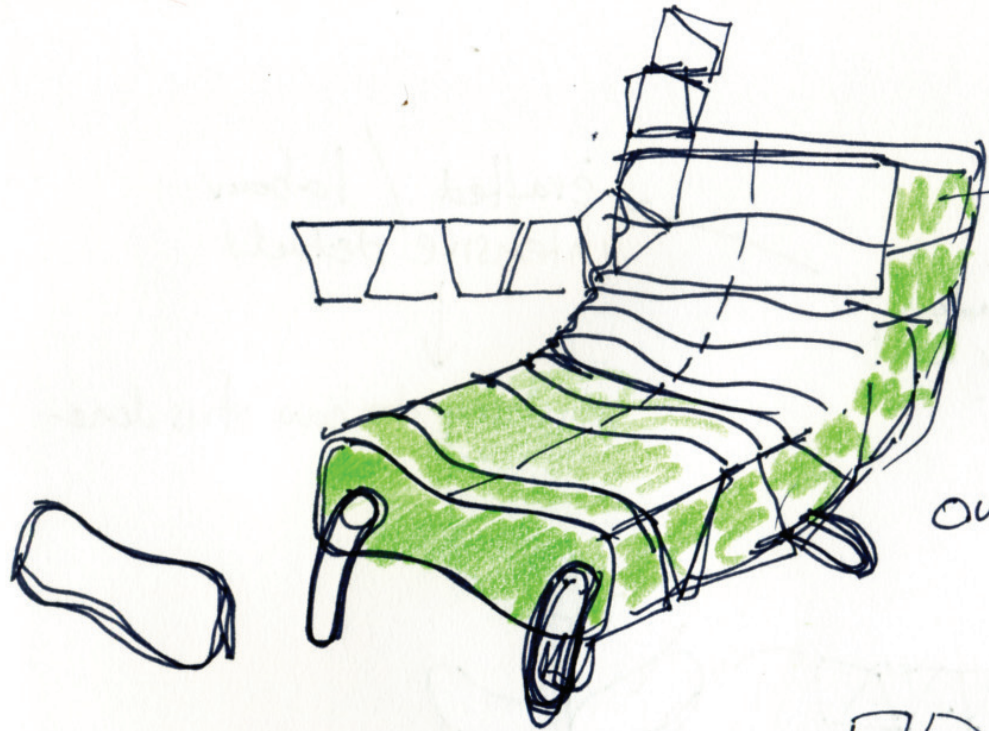

Plastic. or.  
rigid foam?  
laser cut.

Outdoor chair.

Outdoor  
chair

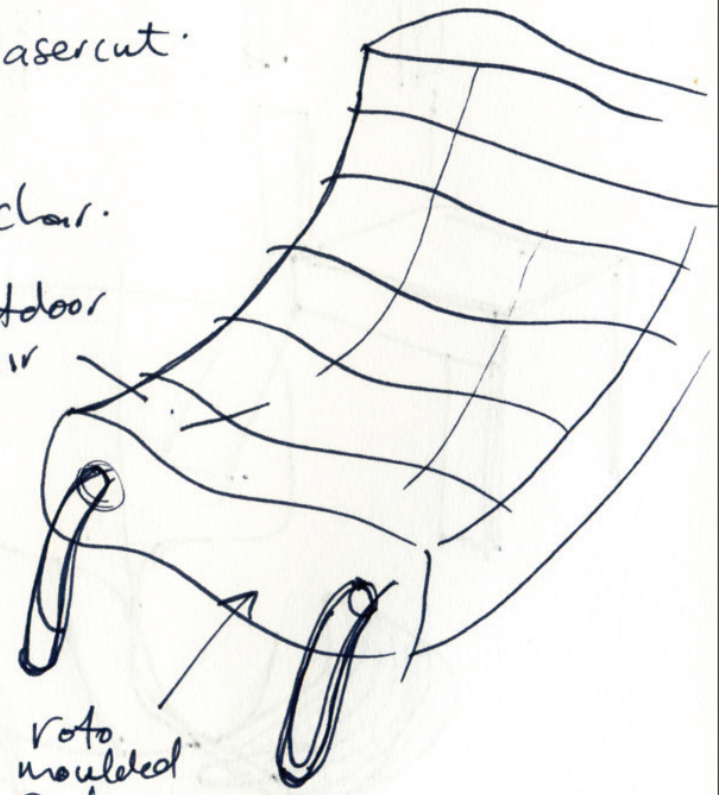

rotomoulded  
sections

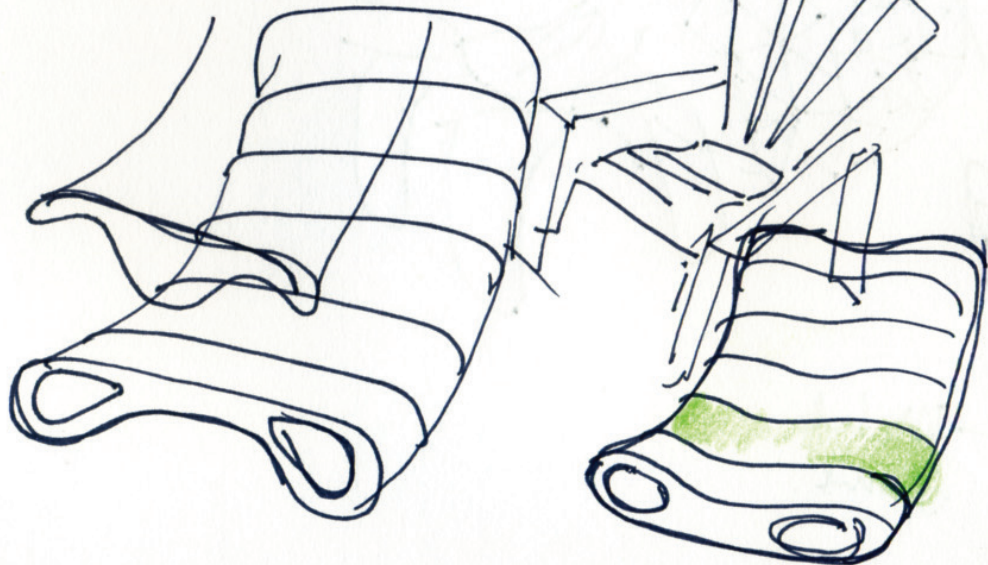

where is the craft?  
limited edition.?

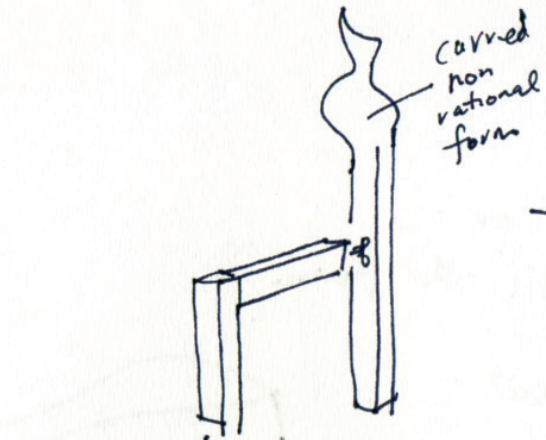

→ This is craft as the result is hand made. no matter what material.

→ crafted / labour intensive details  
↓  
mystery to how it is done

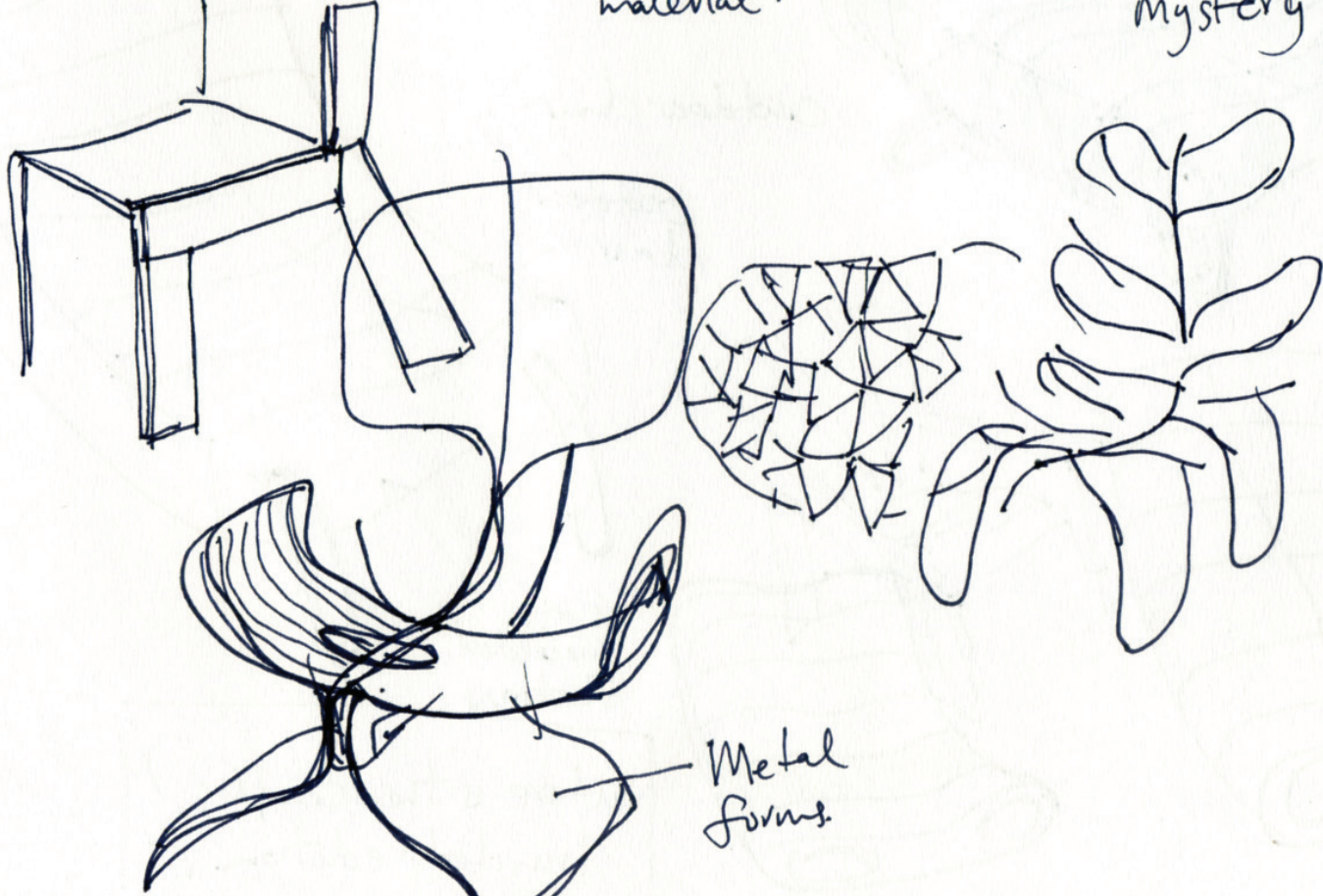

→ Metal forms.

© Jason Klenner 20 January 2010

- is exploring the area between craft and design about production using craft techniques?

Mora says, it is about manufacturing in volume where one process is outsourced/  
not made by the designer/crafter.

design | manufacture.

design ↔ manufacture —

or a high crafting content.

Materials suited to craft are.

- timber
- metal

or any material that can be worked  
into a form/shape.

Joining materials  
to create a pattern./random.

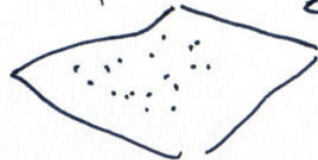

glob of plastic  
material =  
art?

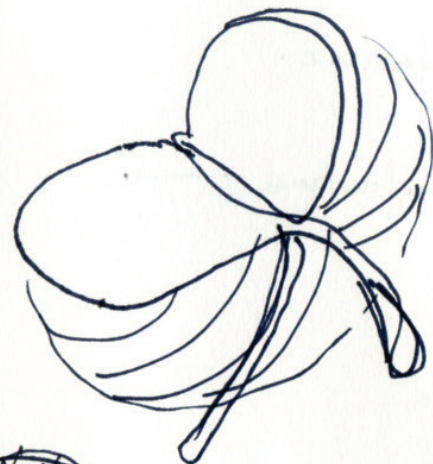
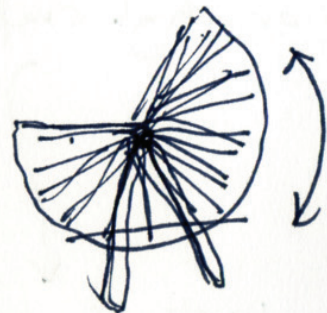

Spring steel.



© Jason Klemmer 21 January 2010

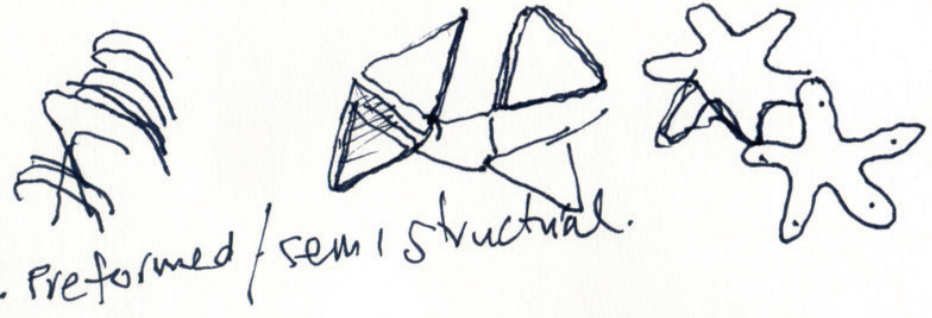

Preformed / semi structural.

woven metal.  
aluminum  
copper  
brass

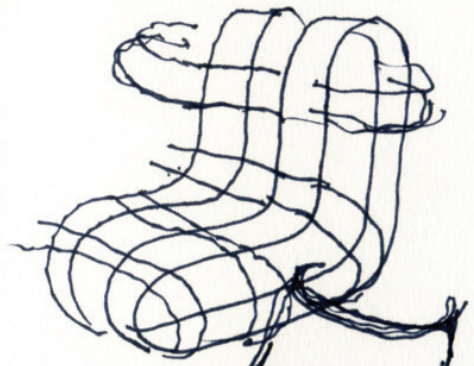

Vac forming over frame.

Crafting = Building something up from a lot of little pieces.

21 January 2010 © Jason Klenner

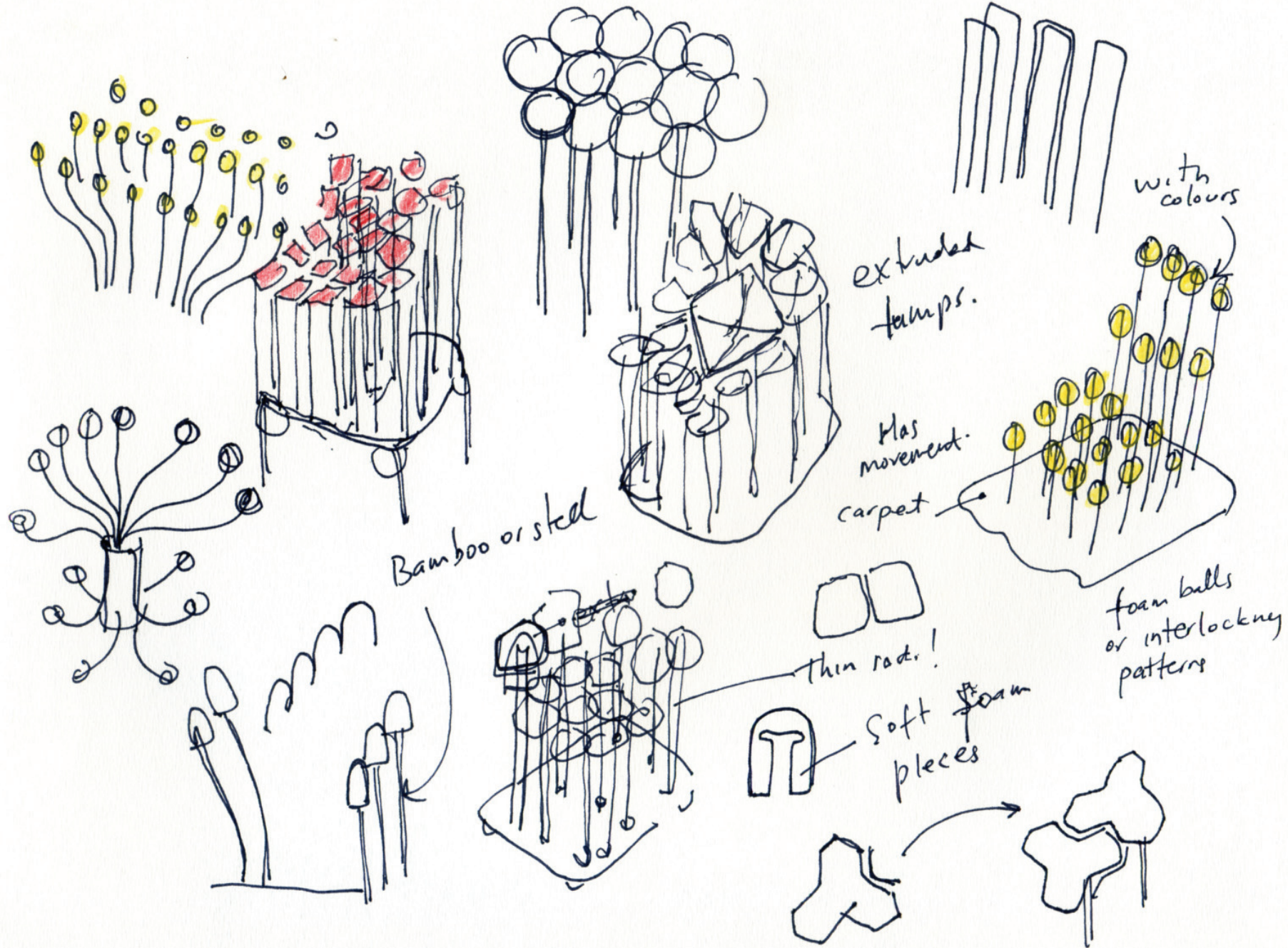

21 January 2010 © Jason Klenner

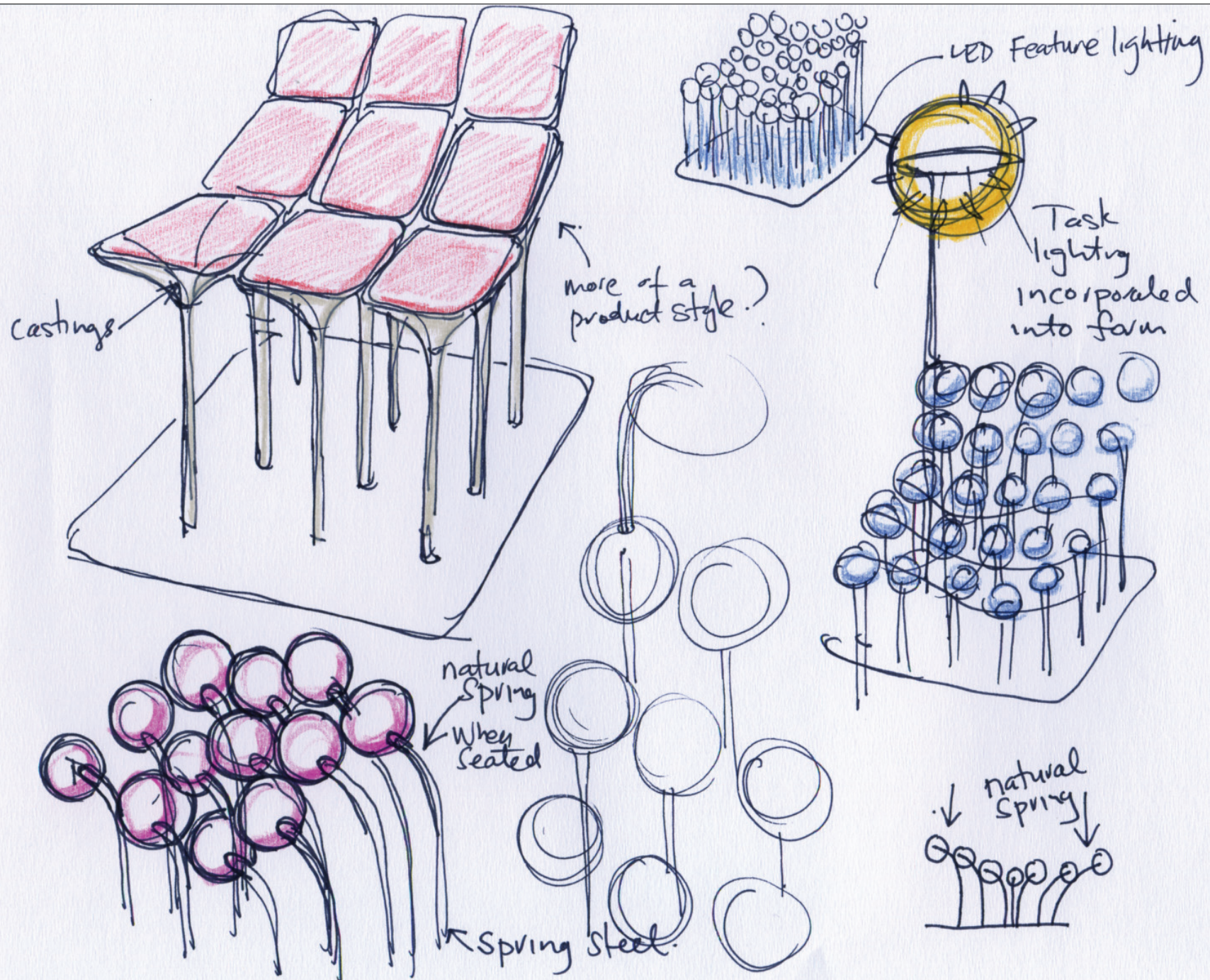

24 January 2010 © Jason Klenner

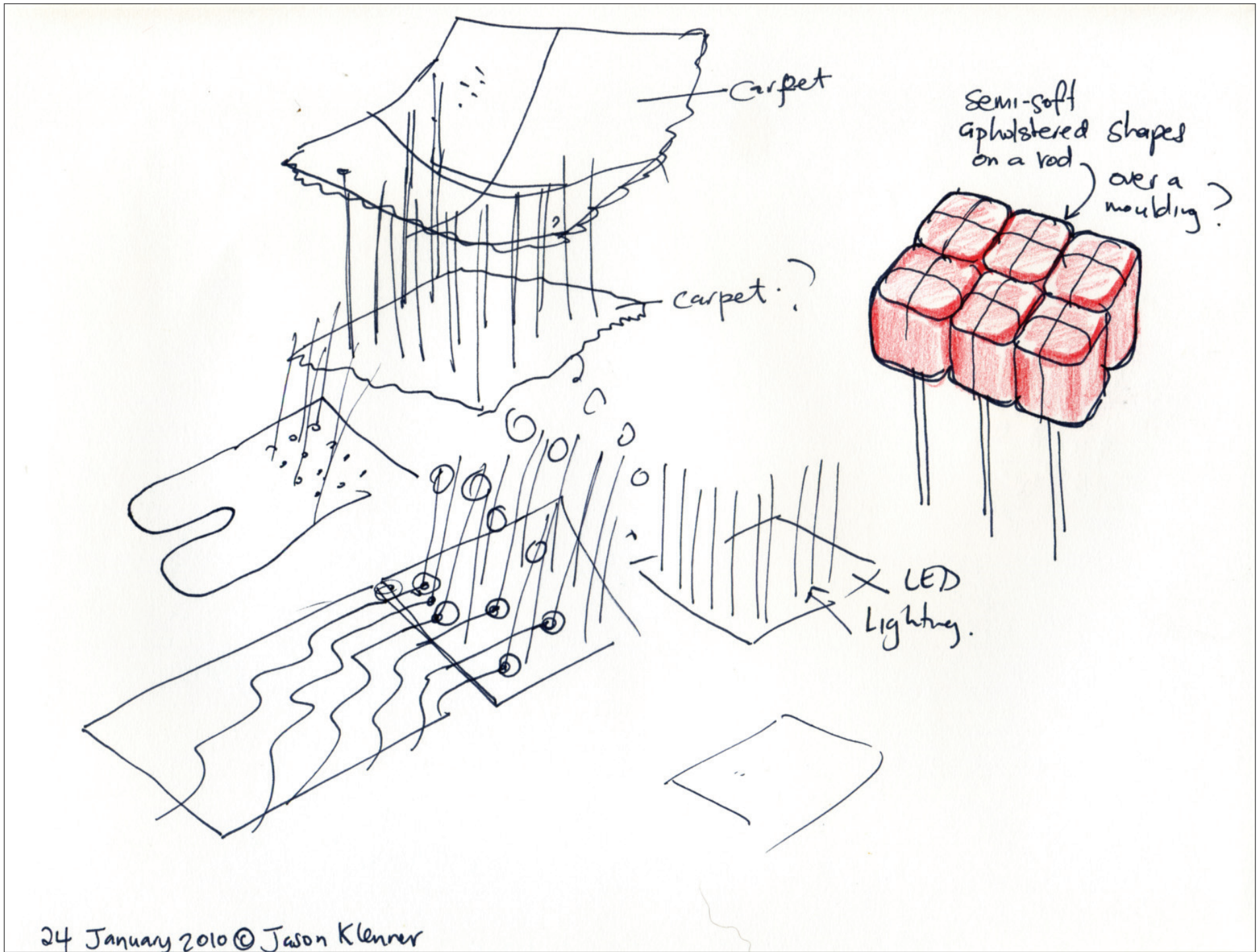

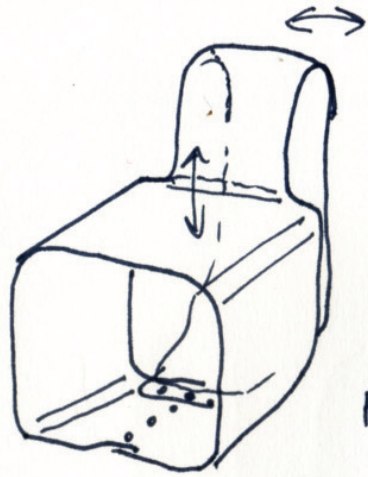

Single sheet  
of material  
plastic or steel?

with a fabric carpet  
covering.

has natural "give" or "spring"

OR

physical  
joints.

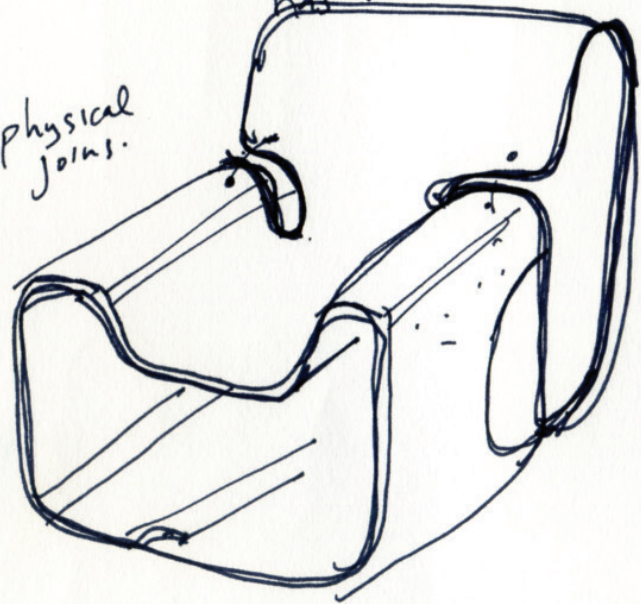

Hollow chair?  
Carpet??  
inside and outside?

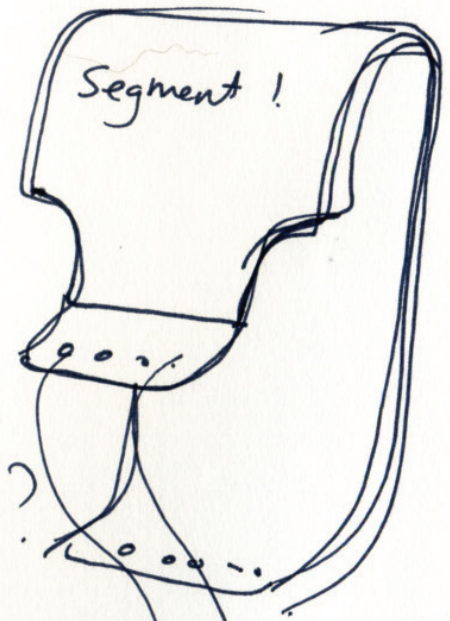

Flat pack?  
made from separate  
segments

interlocking  
carpets.

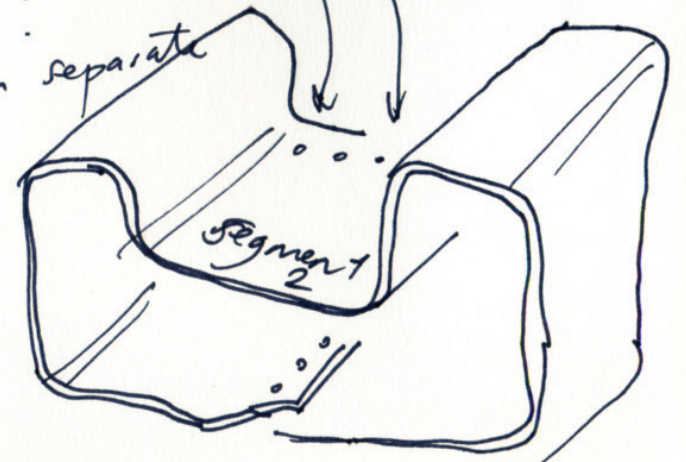

Facet?  
Watch strap?

Too much  
like Grcic?  
?

Natural  
Spring?

Segments

Fabricated  
Style?

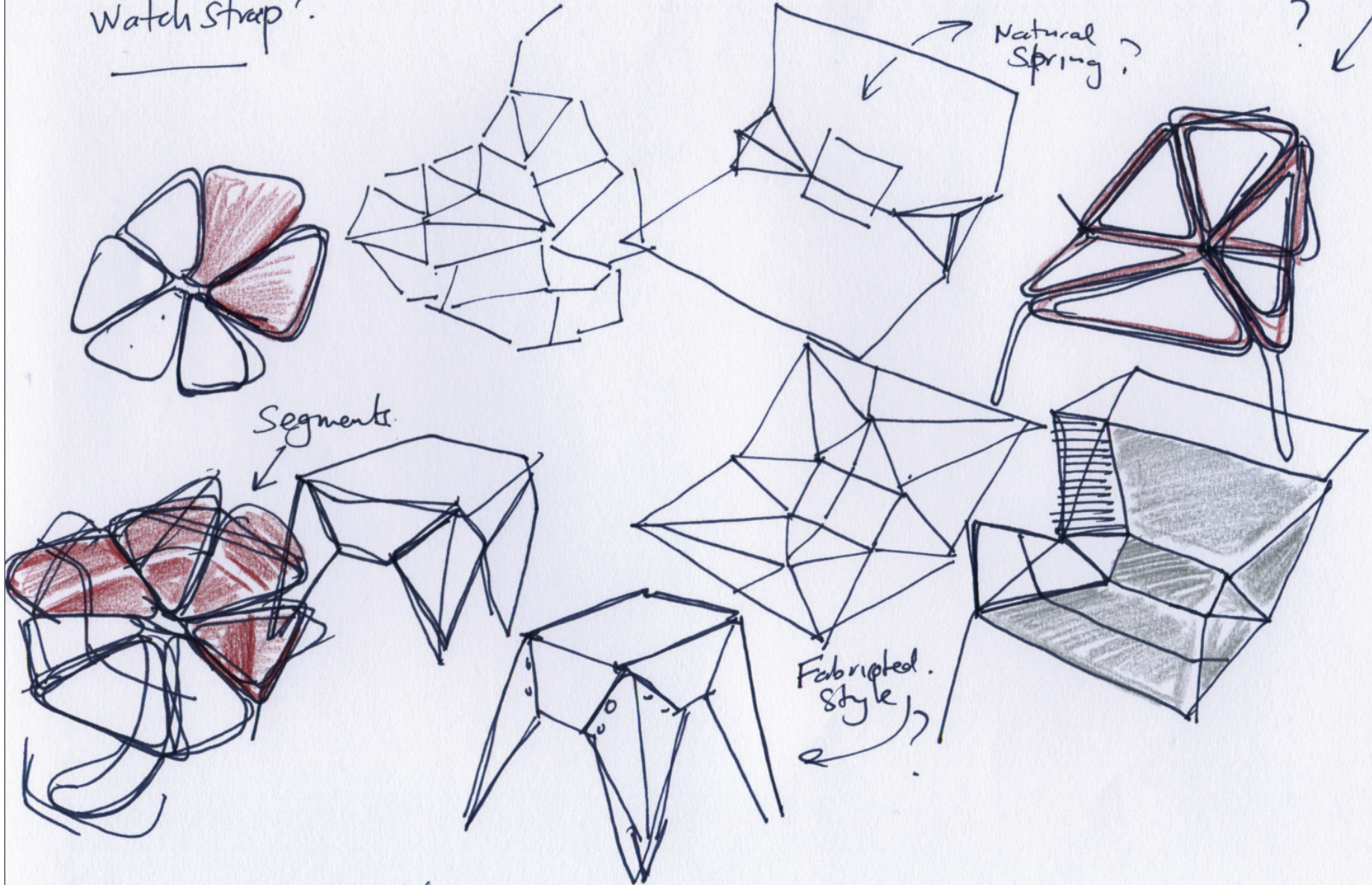

25 January 2010 © Jason Kleen

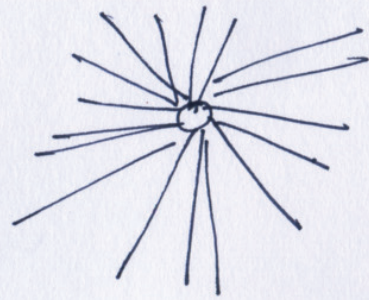
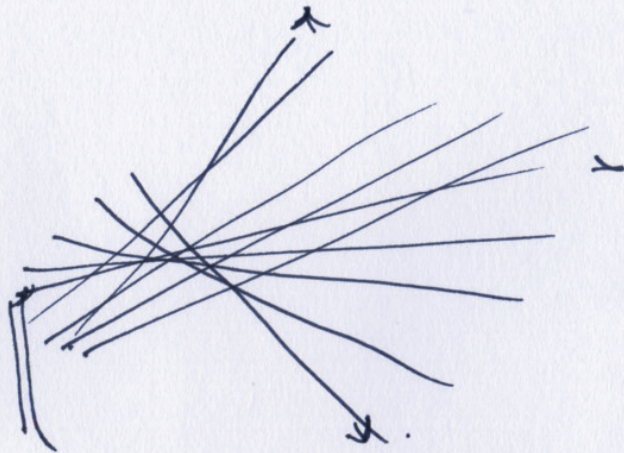

spiders  
web.

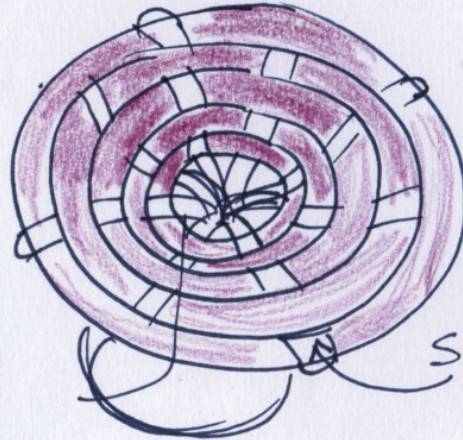
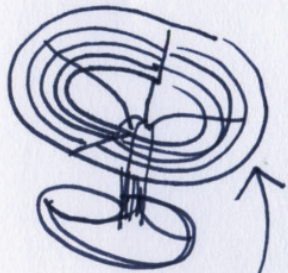
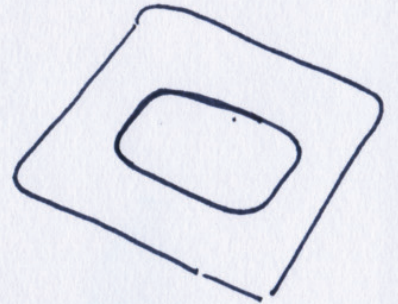

slats/strips

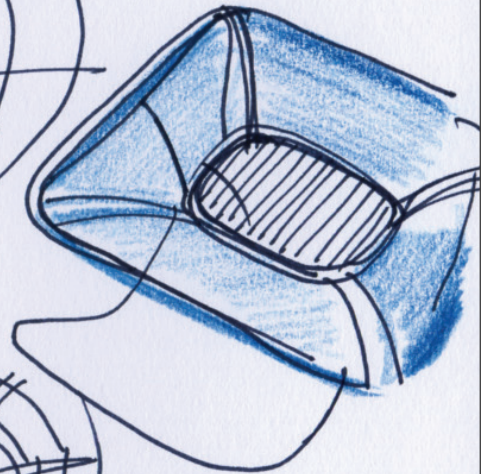
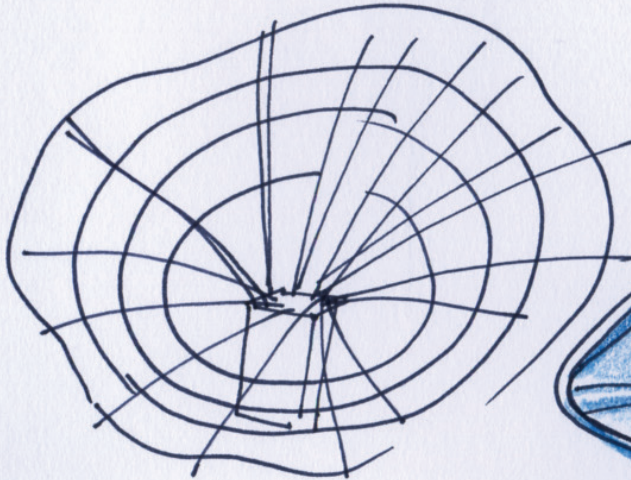

Series of laser  
cut circles ?



25 January 2010. © Jason Klenner

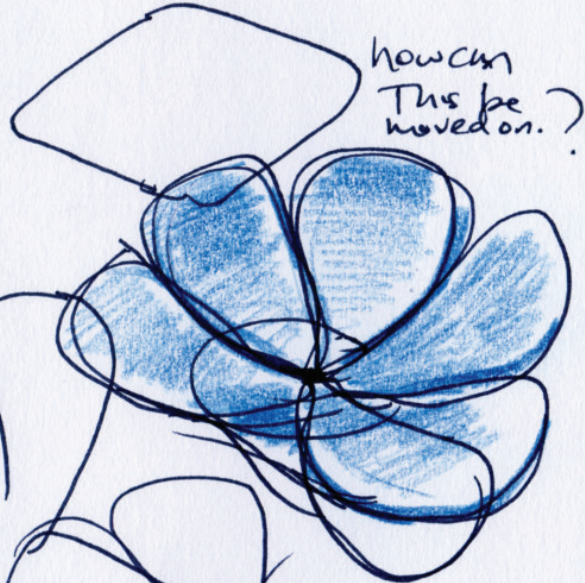
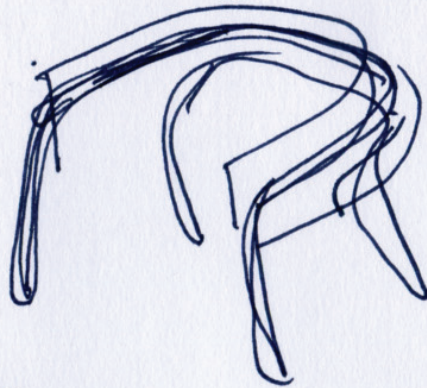
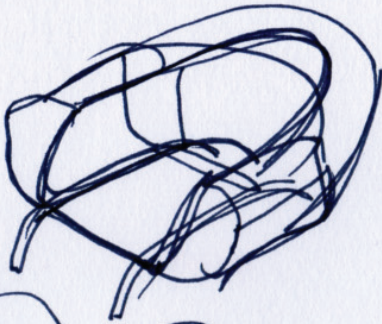

how can  
this be  
moved on.?

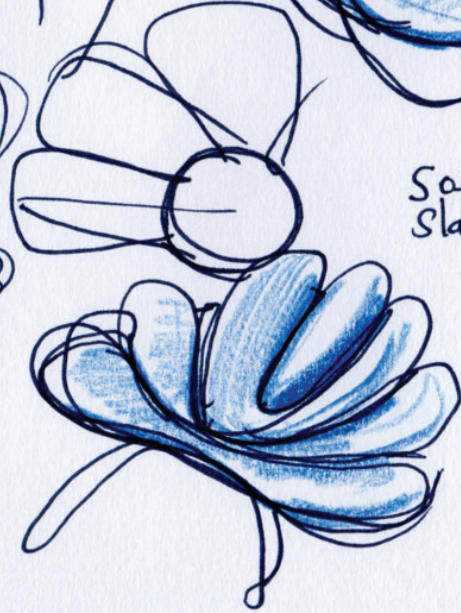
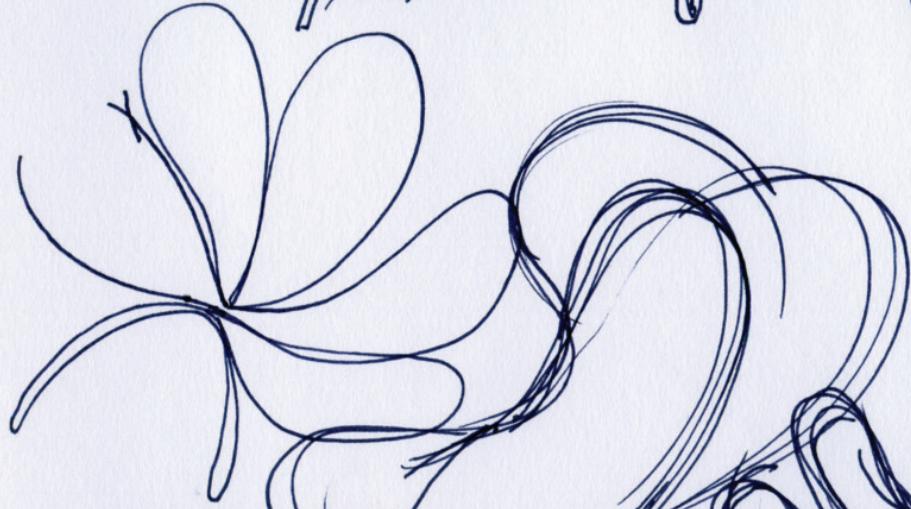

Soft  
slats

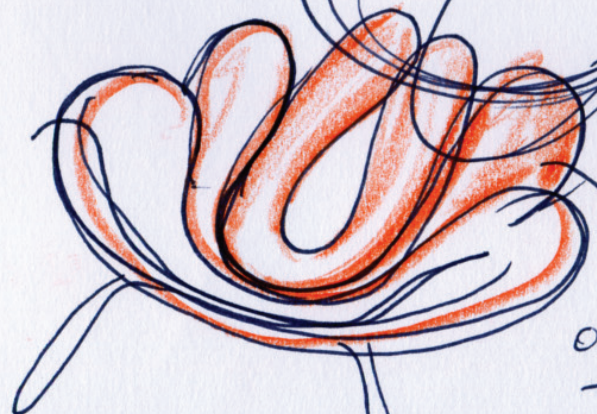

Soft  
Slats.  
outdoors/  
flower chair.

25 January 2010 © Jason Klenner

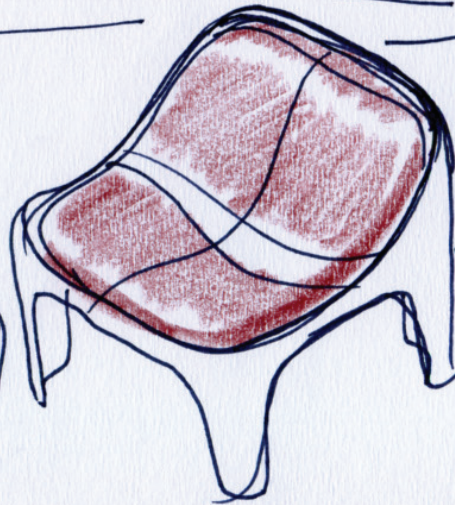
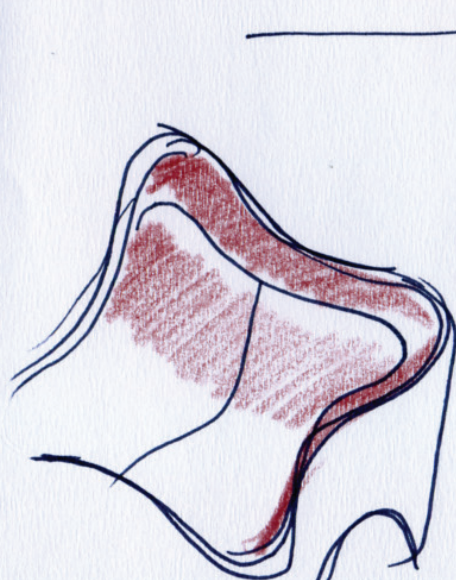
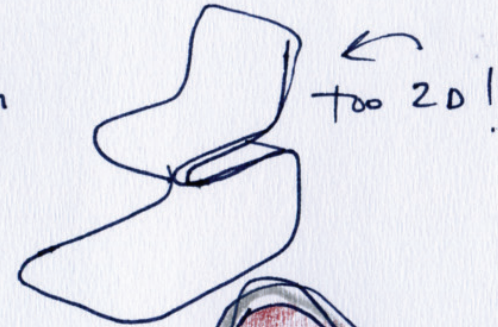
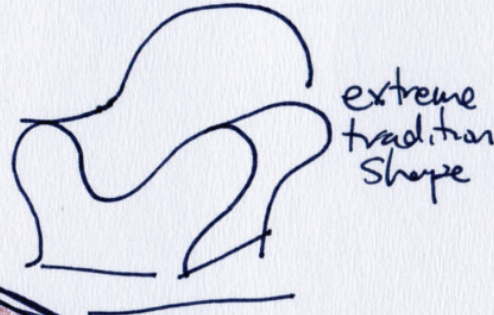
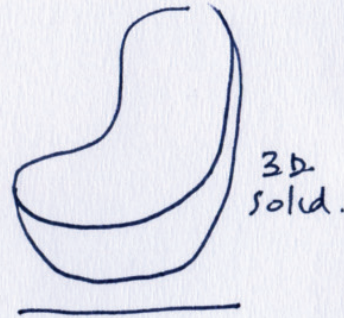
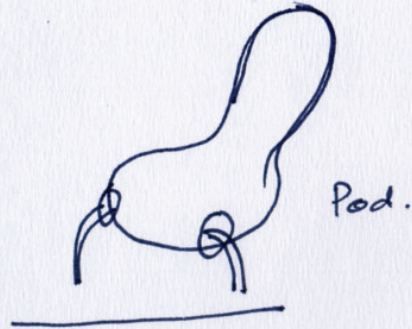

Clean/  
Simple.  
form.

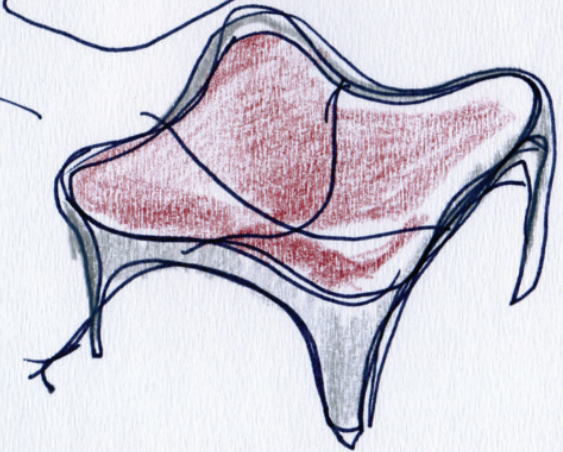

25 January 2010 © Jason Kleener

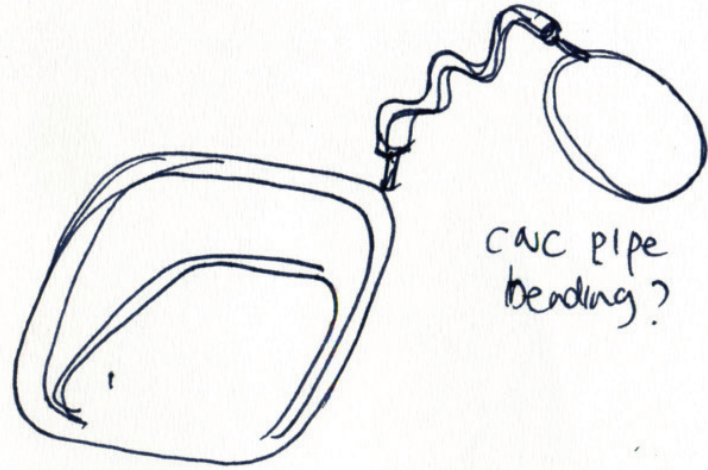
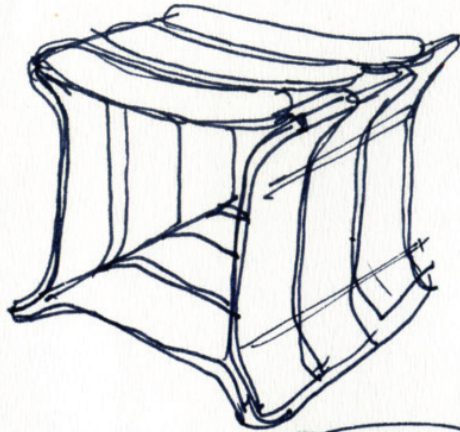

CNC pipe bending?

Chair mounted into the ground

Steel forming?

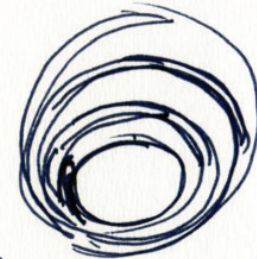
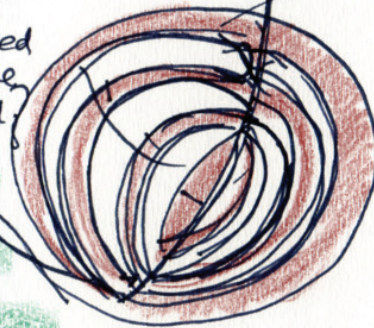

Carpet chair?

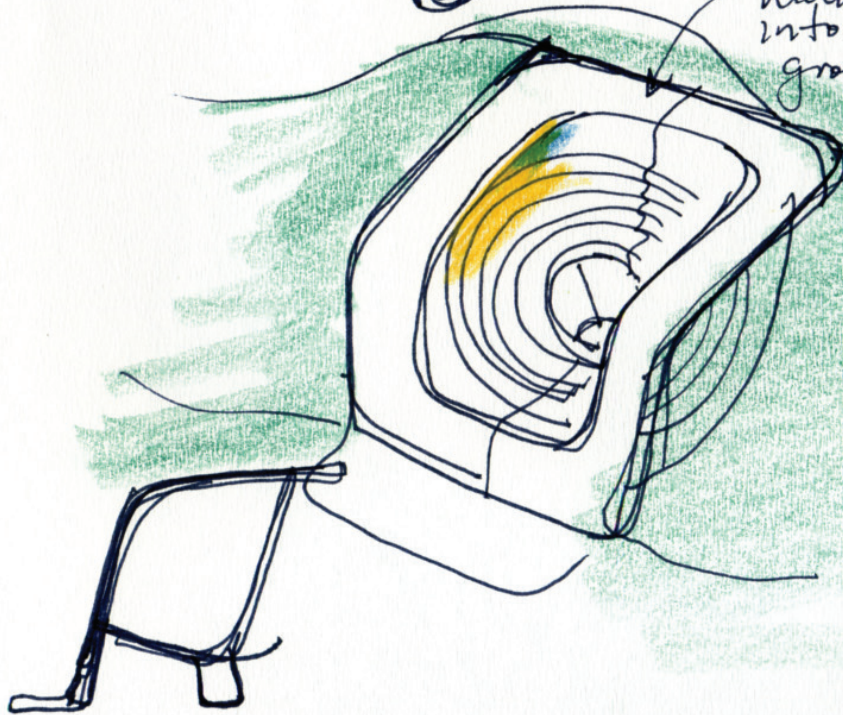

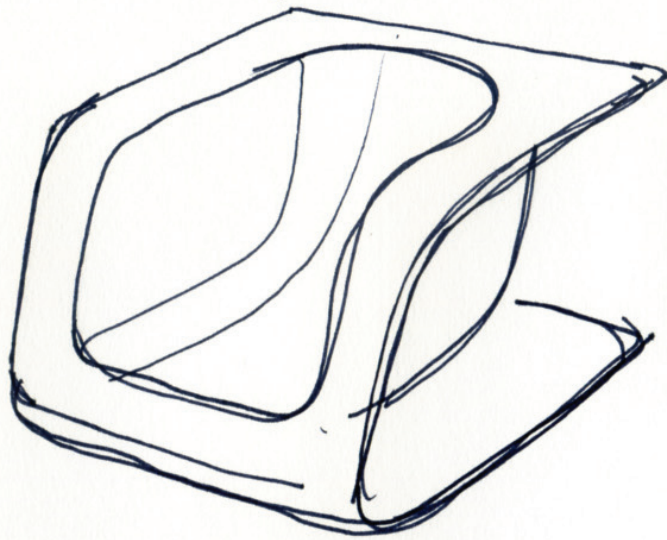

how about a form?

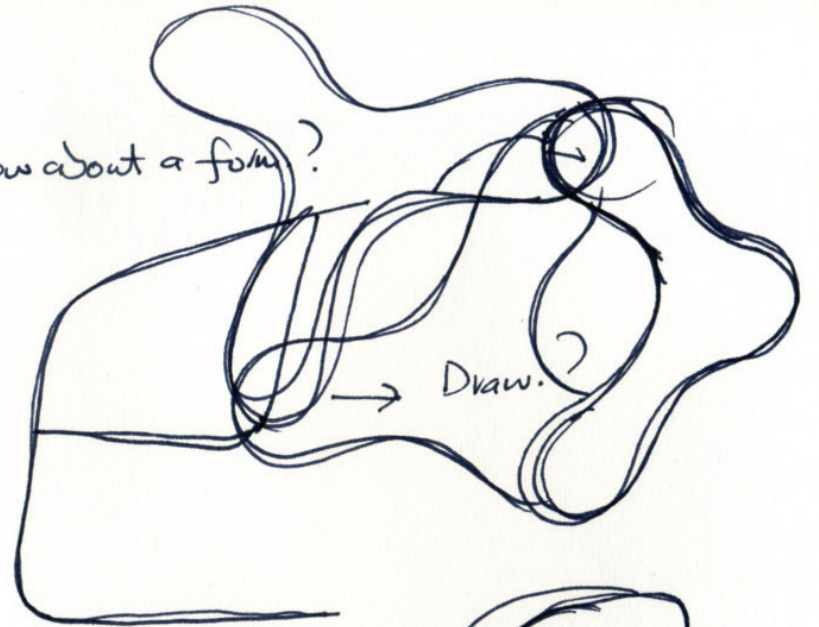

Draw.?



Neuron

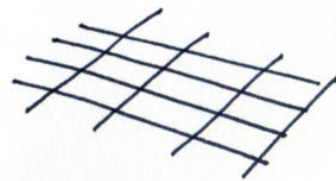

slates

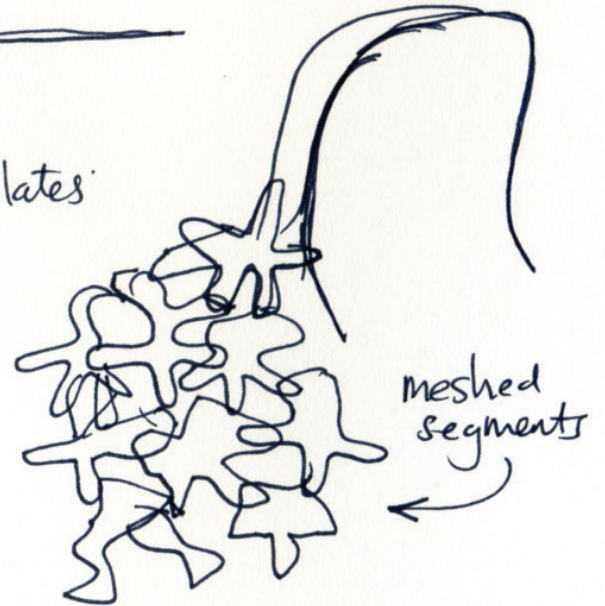

meshed segments



25 January 2010. © Jason Klenner

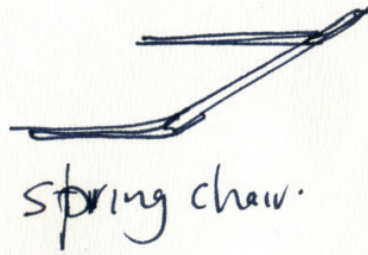
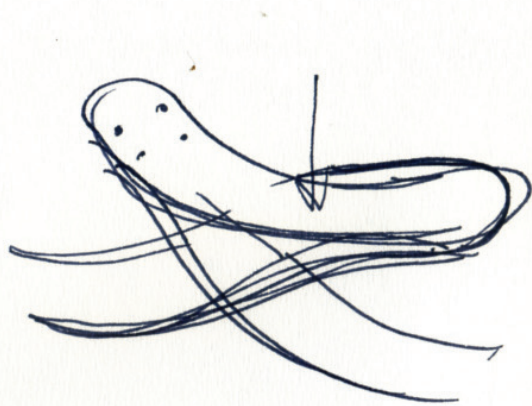

spring chair.

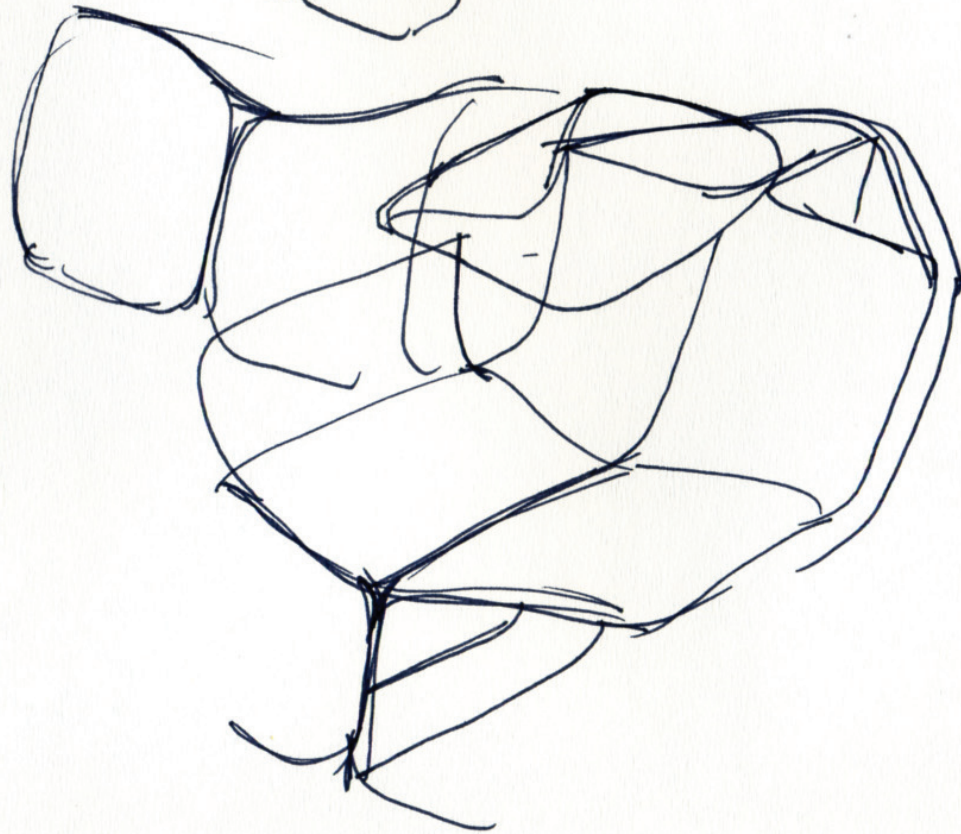
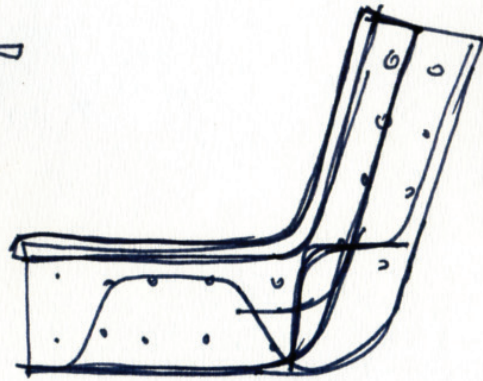
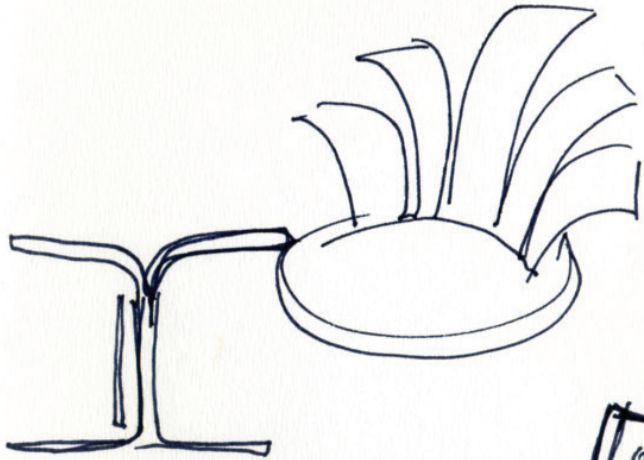
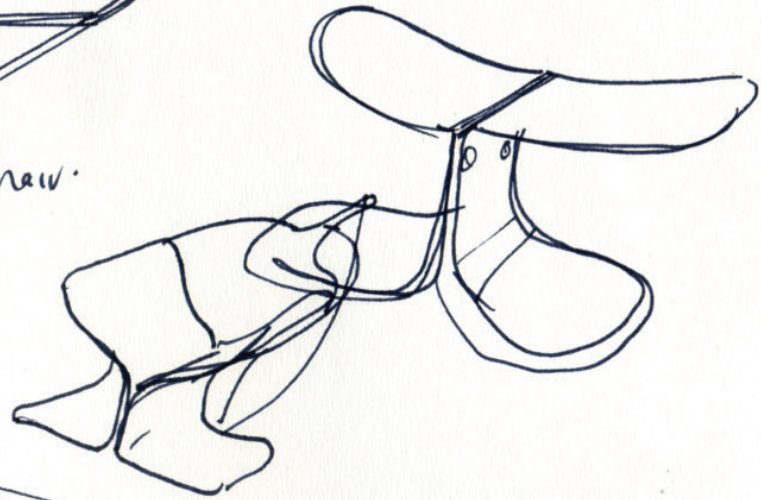

25 January 2010 © Jason Klenner

Joined back  
and seat pan.?

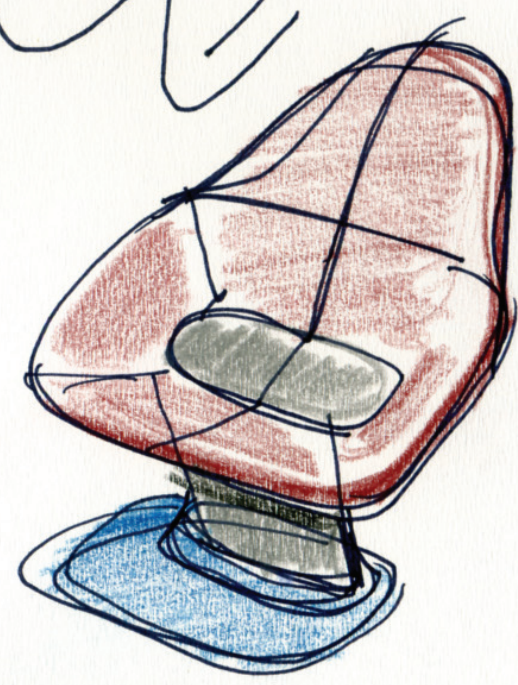
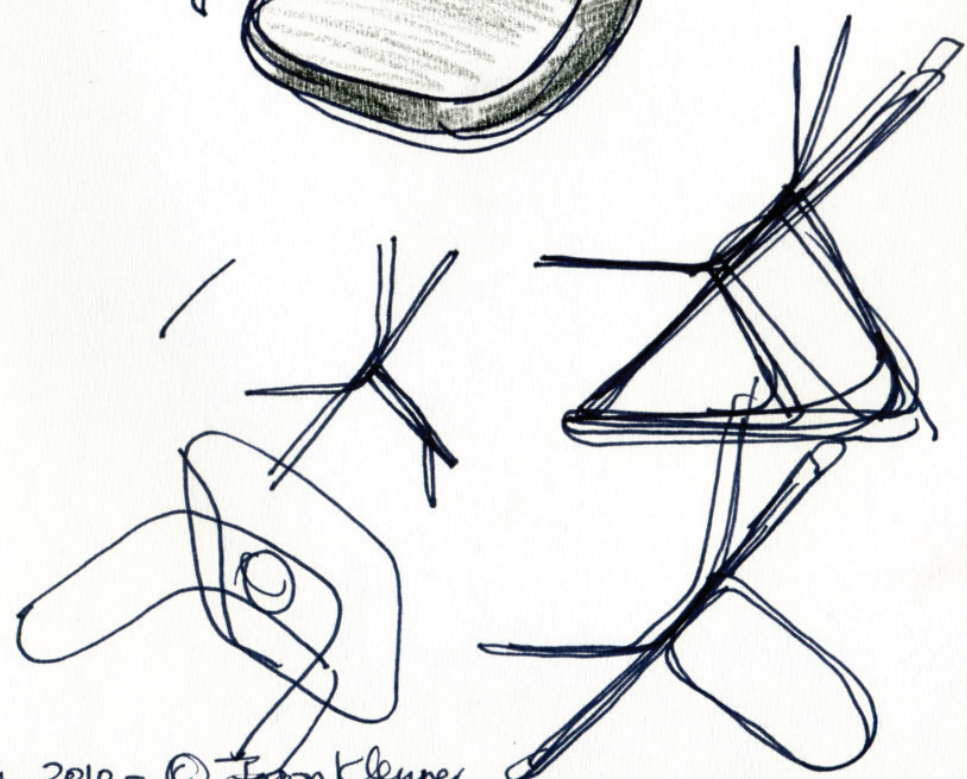
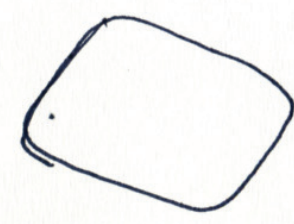
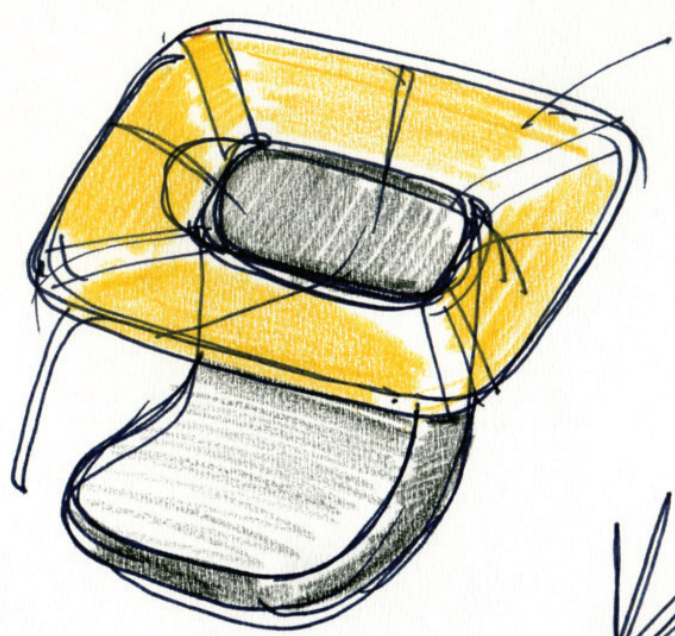

21 January 2010 - © Jason Kleener



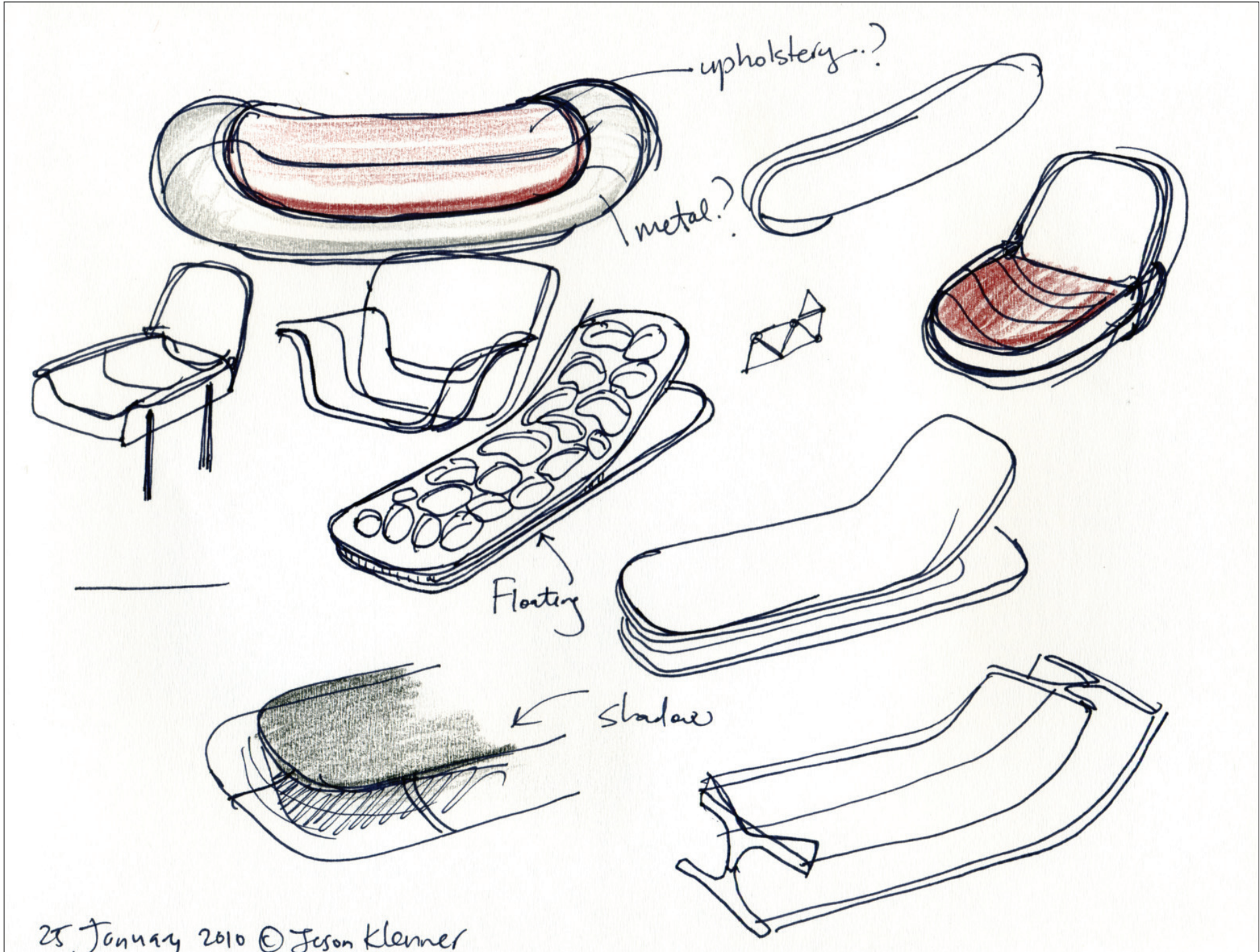

25 January 2010 © Jason Klemmer

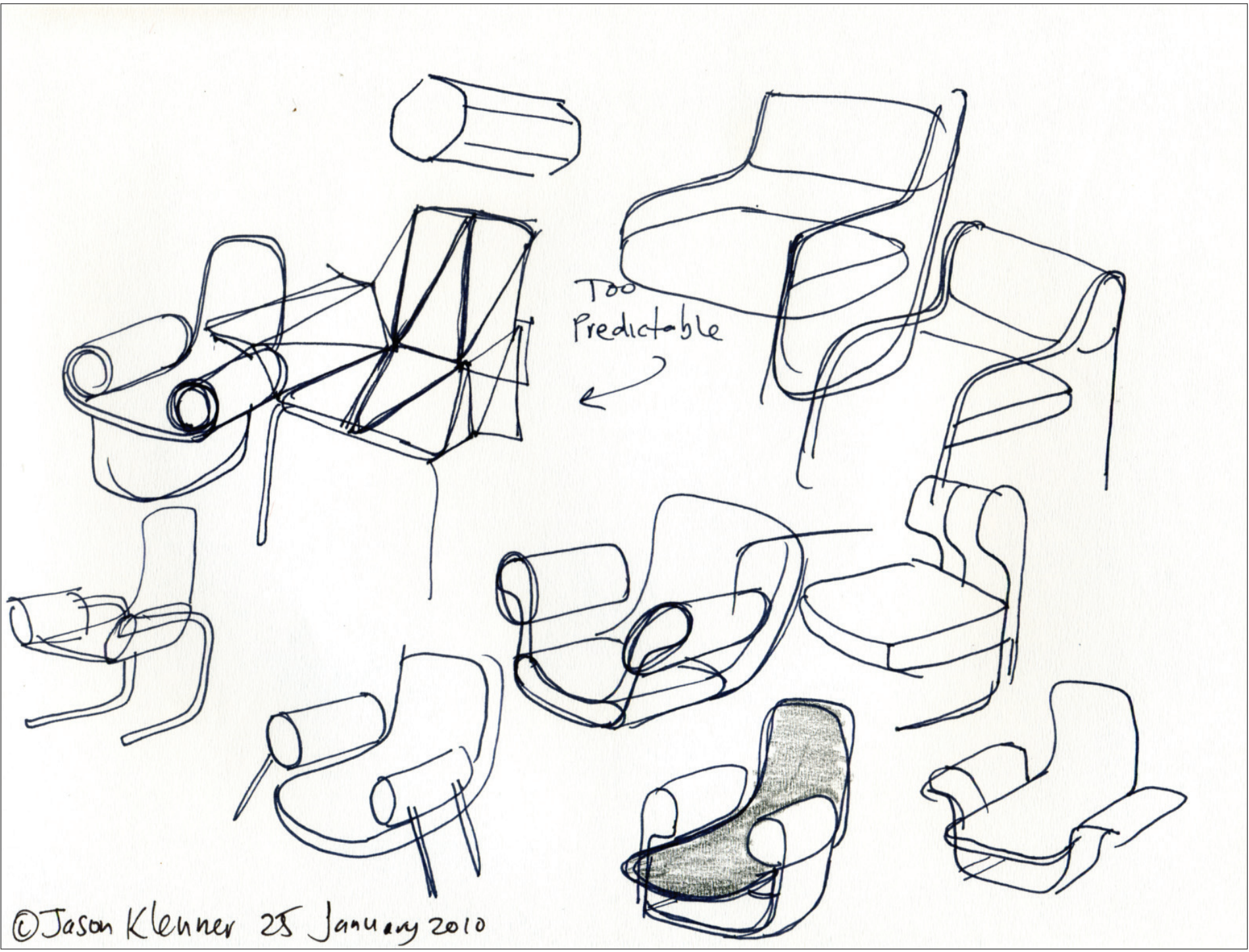

©Jason Klenner 28 January 2010

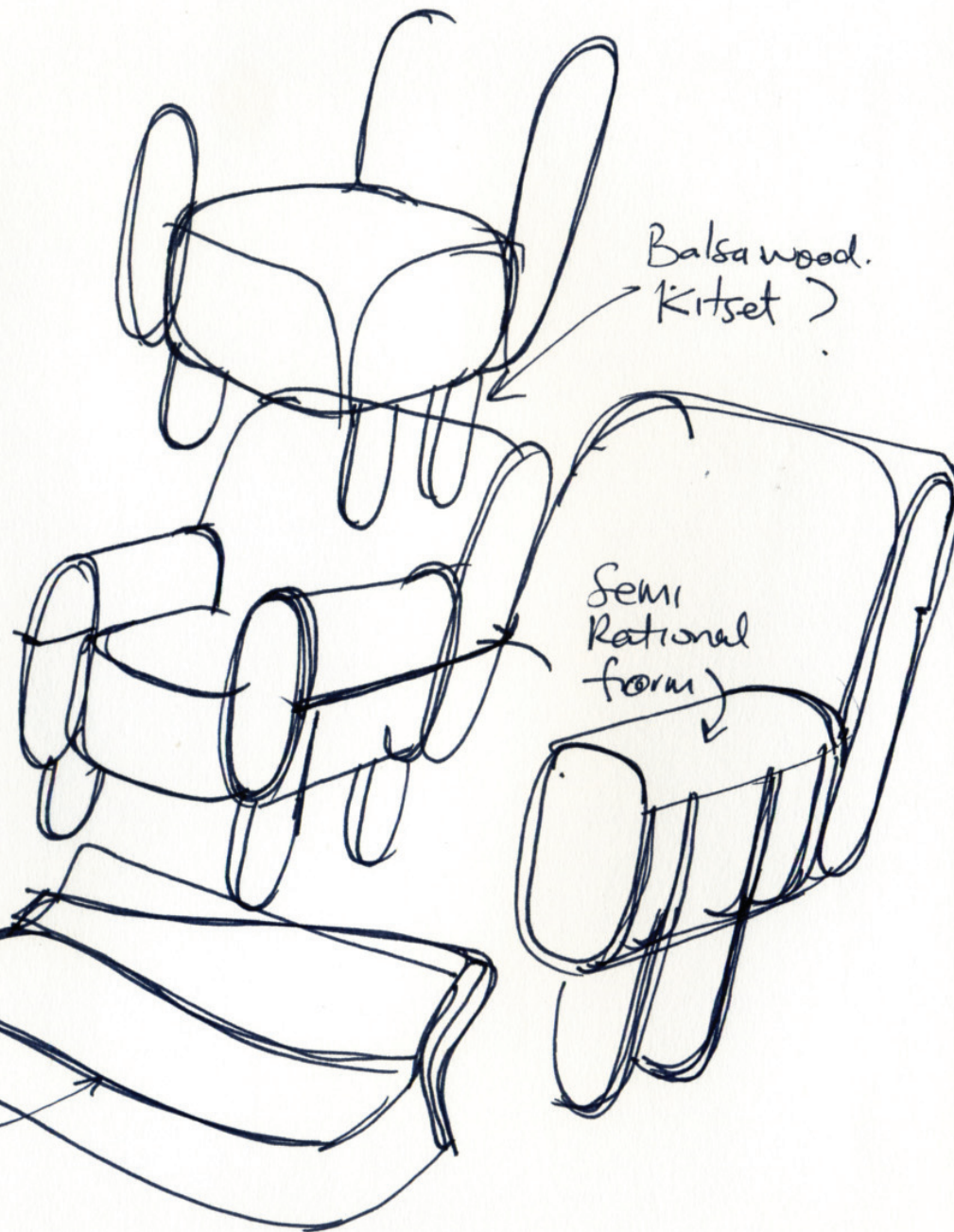
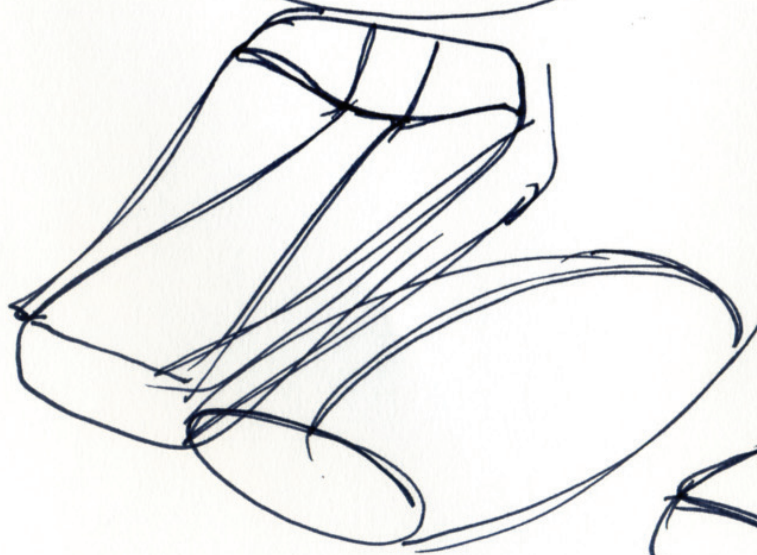
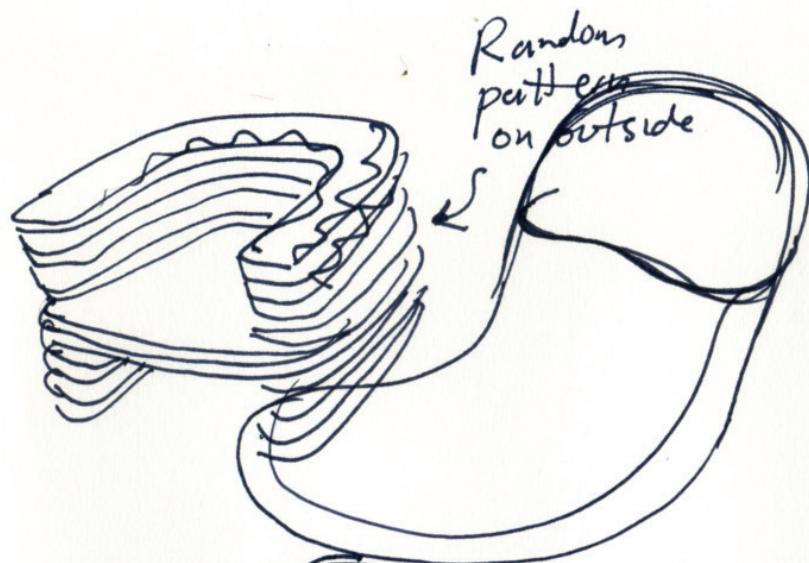

25 January © Jason Klemer

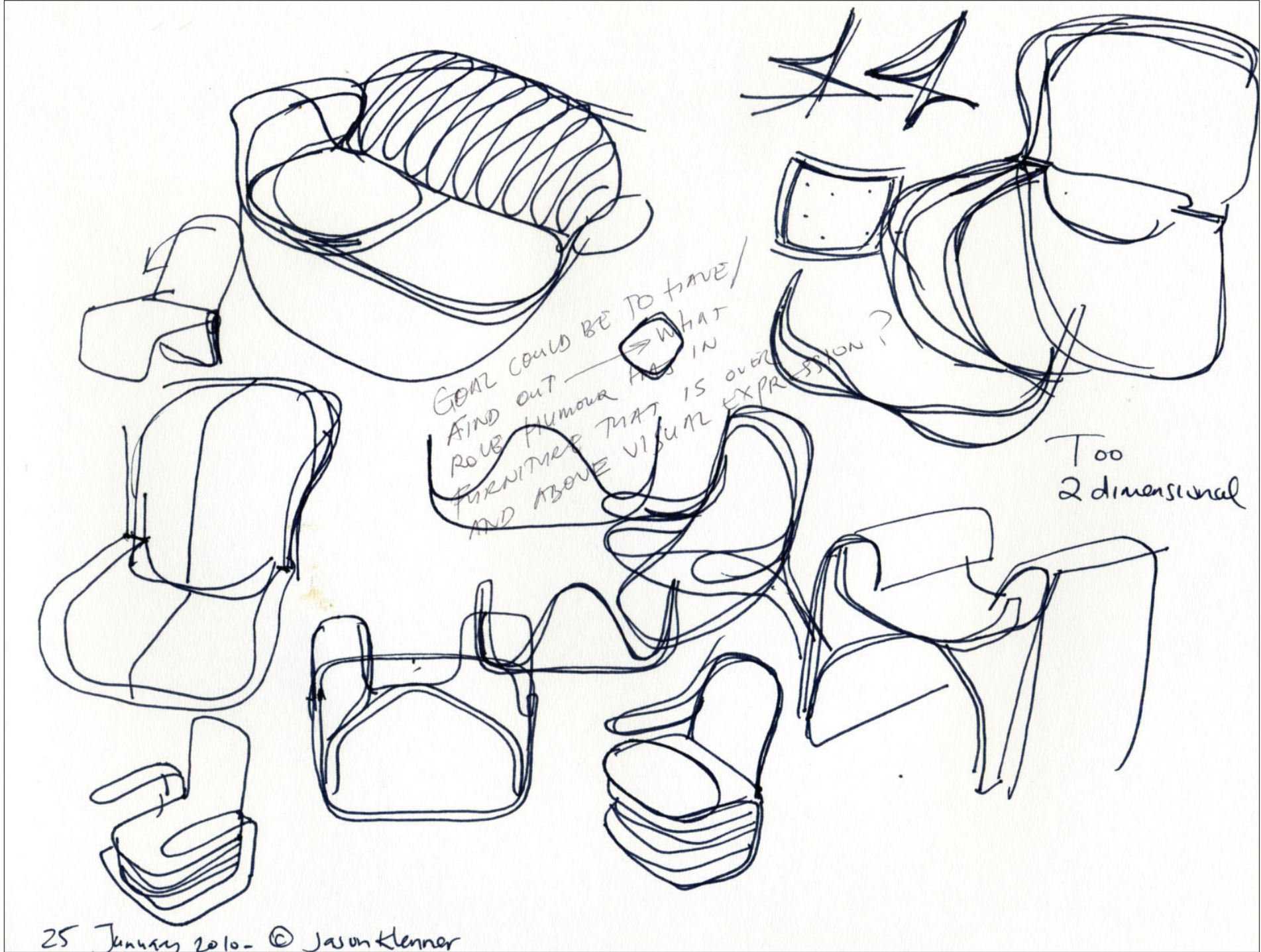

GOAL COULD BE TO HAVE /  
FIND OUT —  WHAT  
ROLE HUMOUR HAS IN  
FURNITURE THAT IS OVER  
AND ABOVE VISUAL EXPRESSION?

Too  
2 dimensional

25 January 2010 - © Jason Klenner

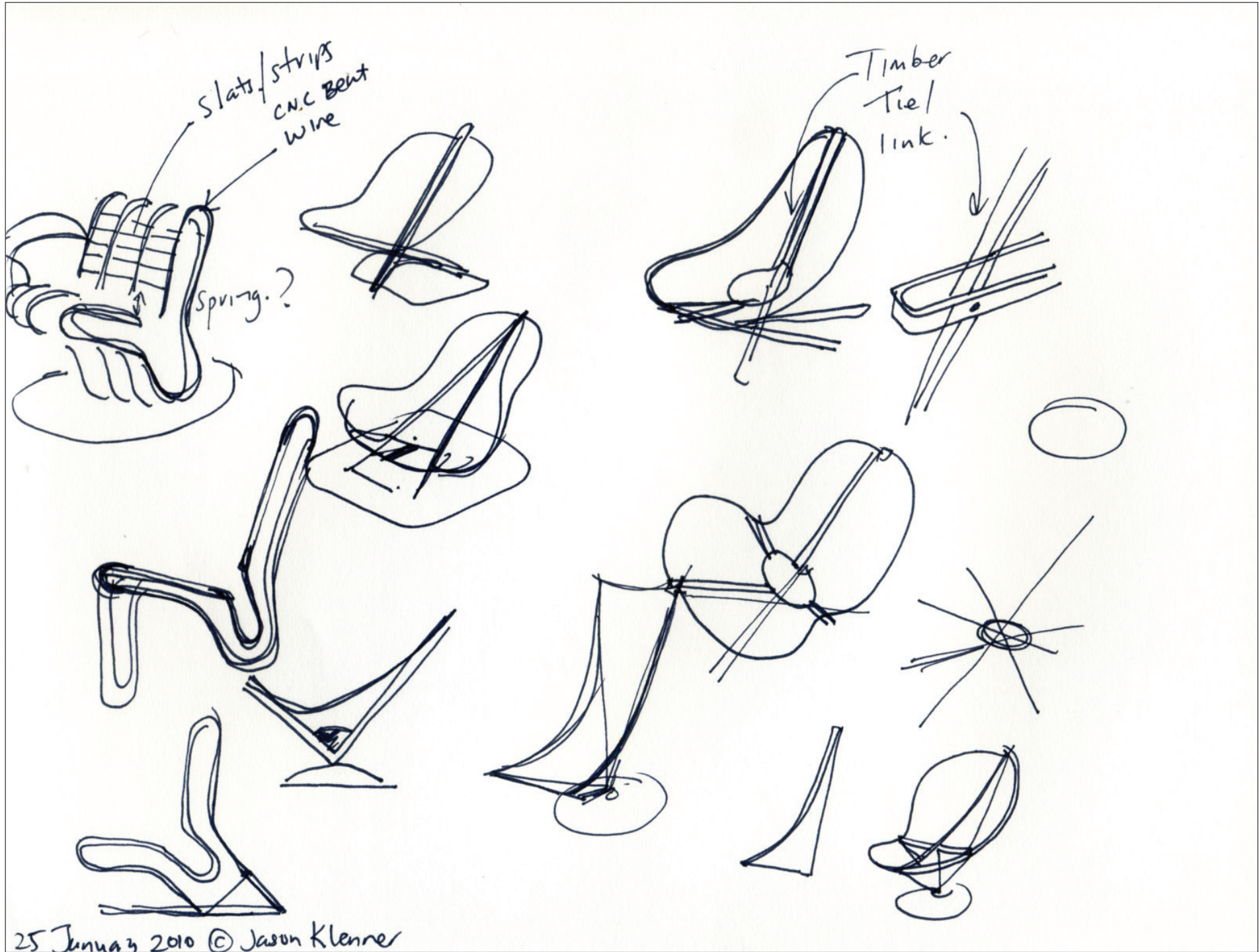

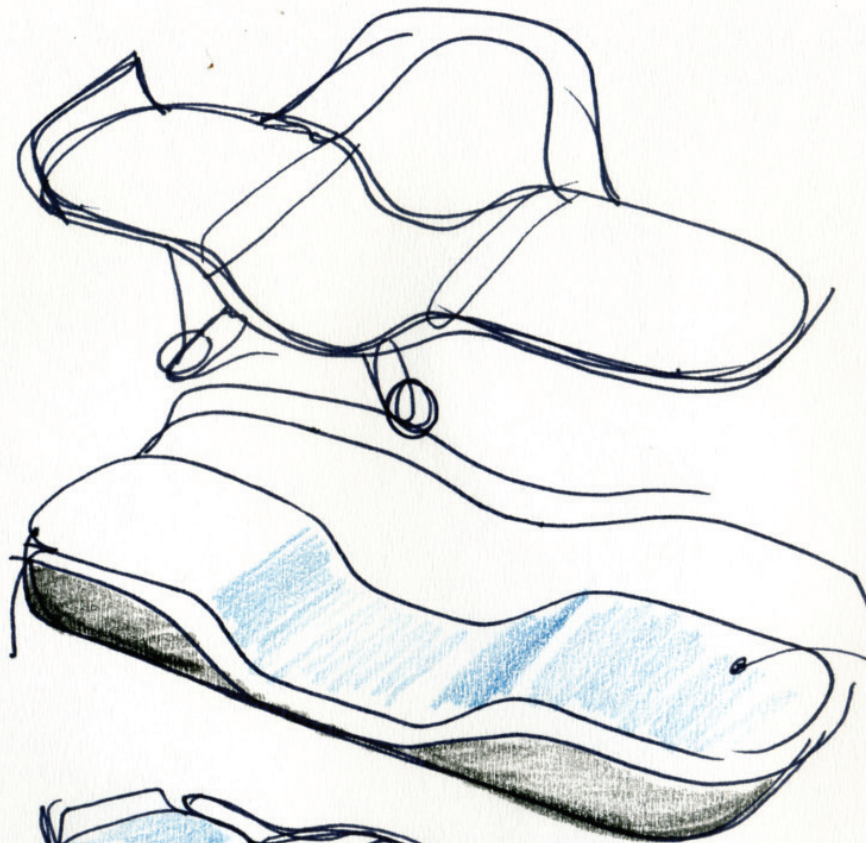

oversized  
armrests

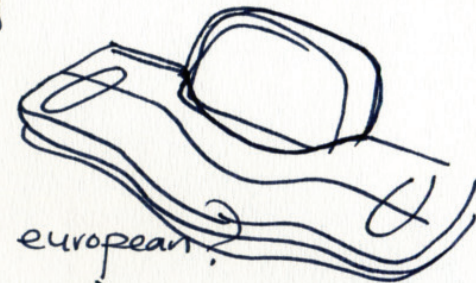
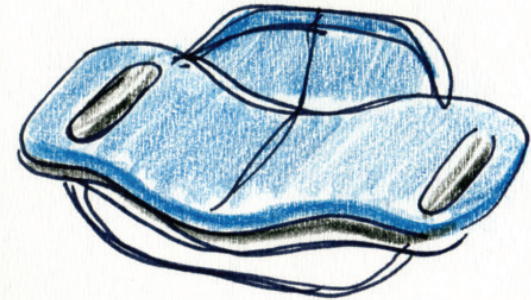
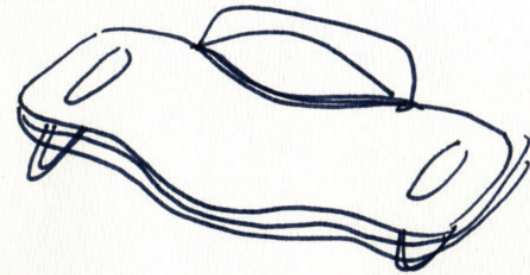

Too european?

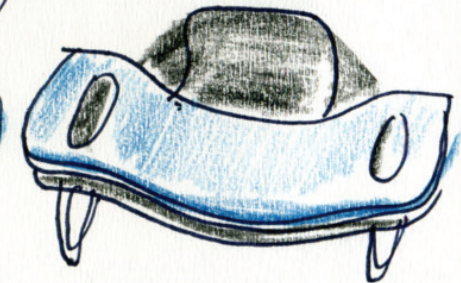
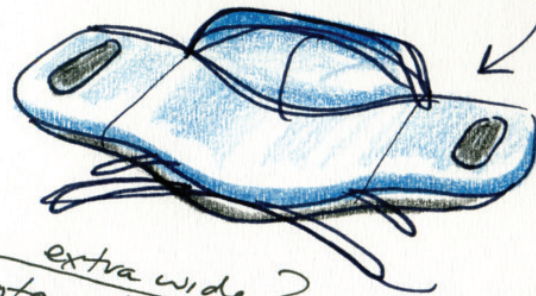
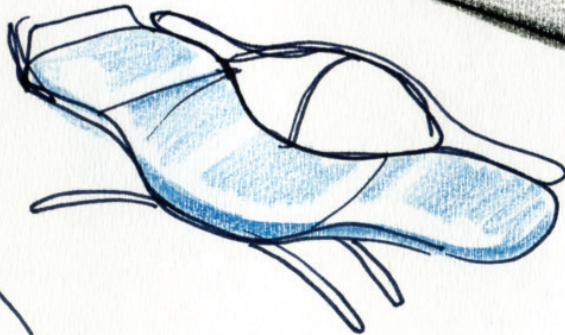

← extra wide? →  
interesting proportions

25 January 2010 © Jason Klenner

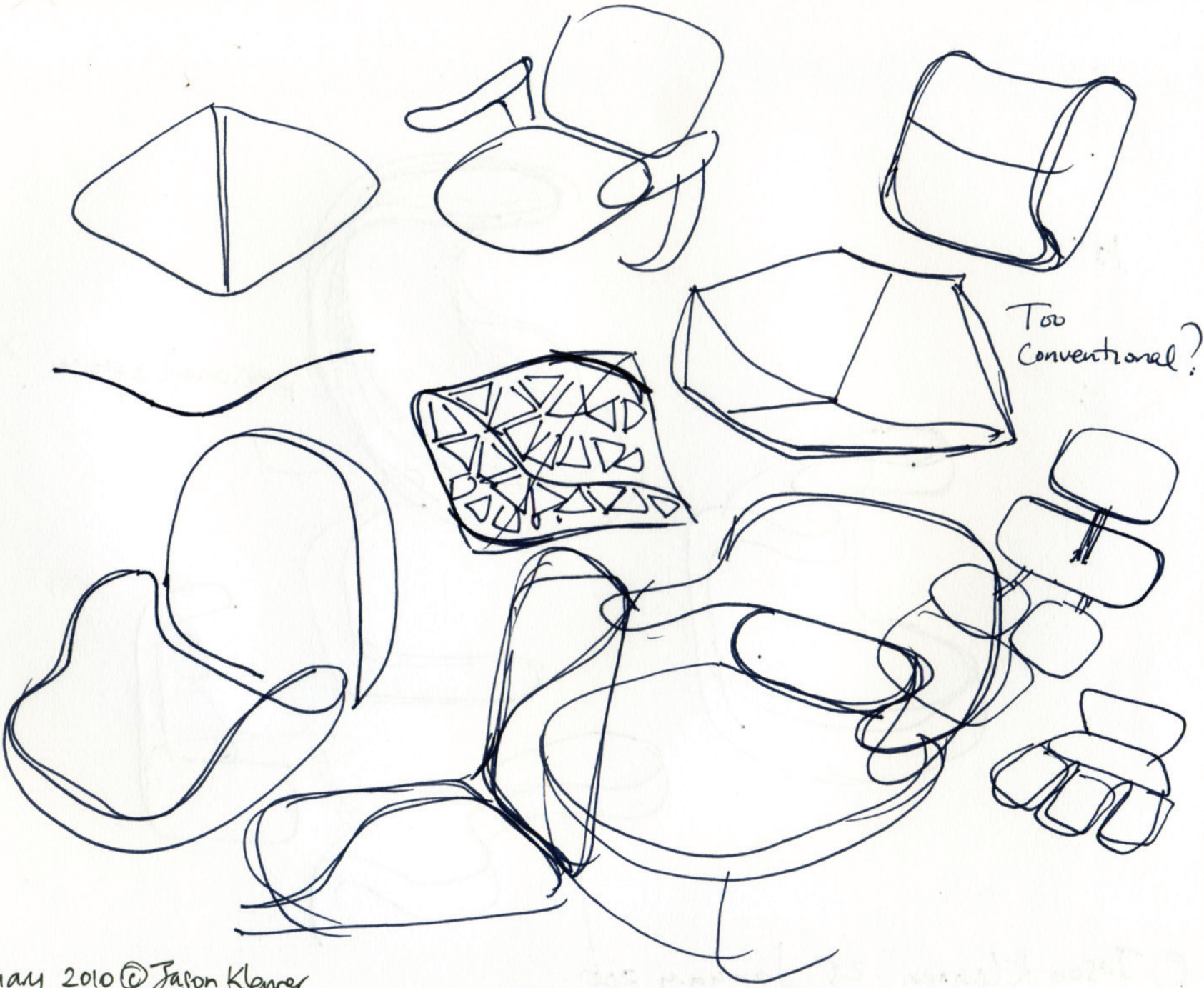

Too  
Conventional?

25 January 2010 © Jason Klenner

Art

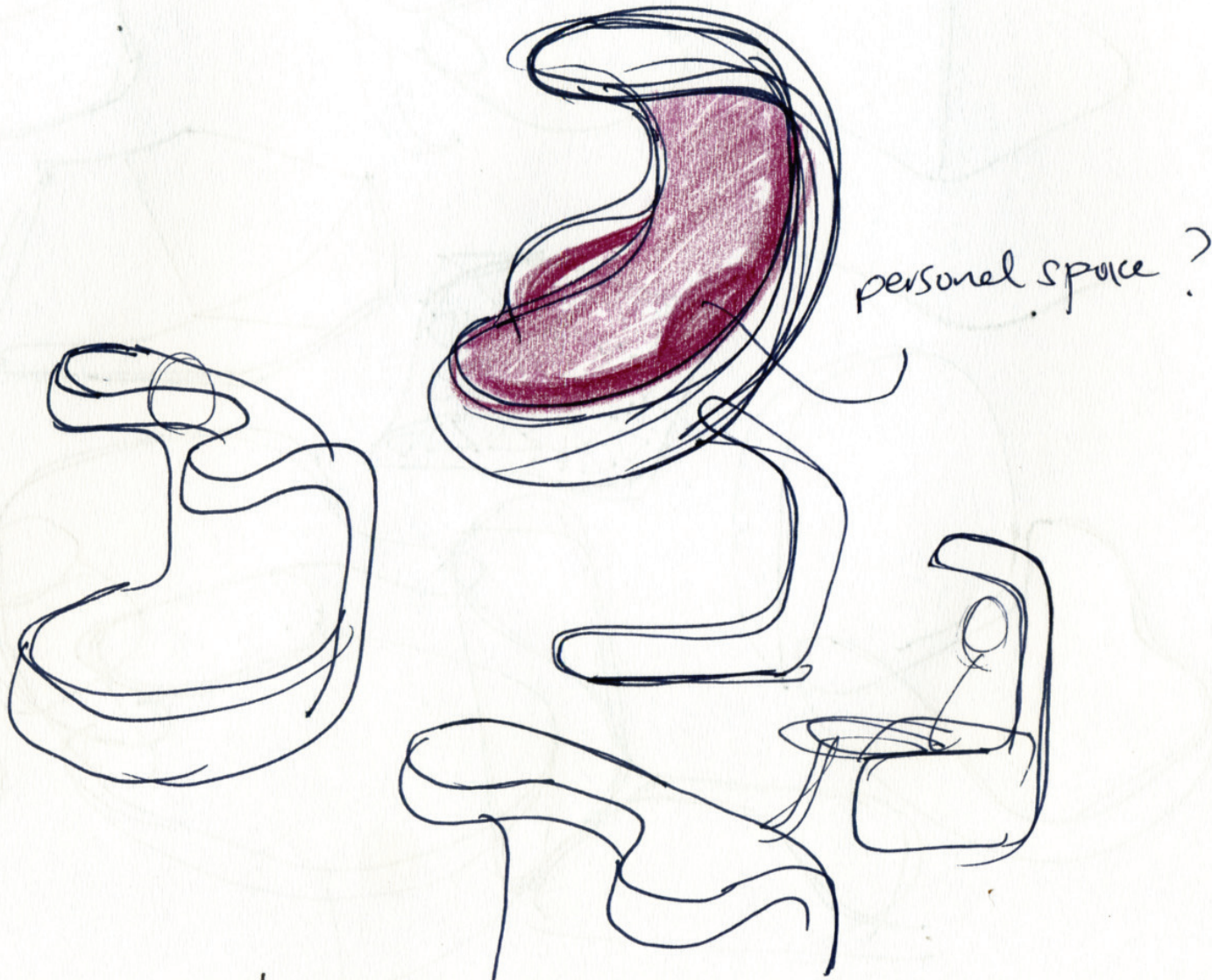

© Jason Klenner 25 January 2010

1. Spheres
2. Carpet wrap.
3. Round. weave



Round weave.  
Metal?

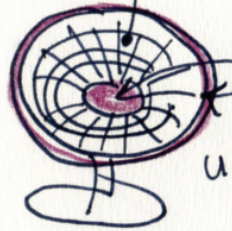

upholstery

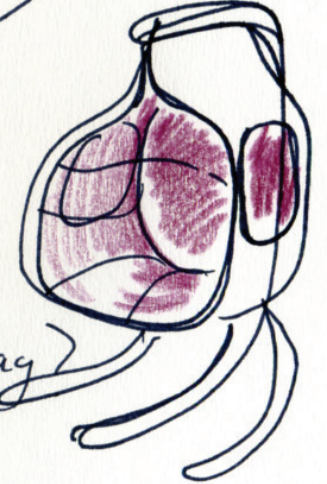
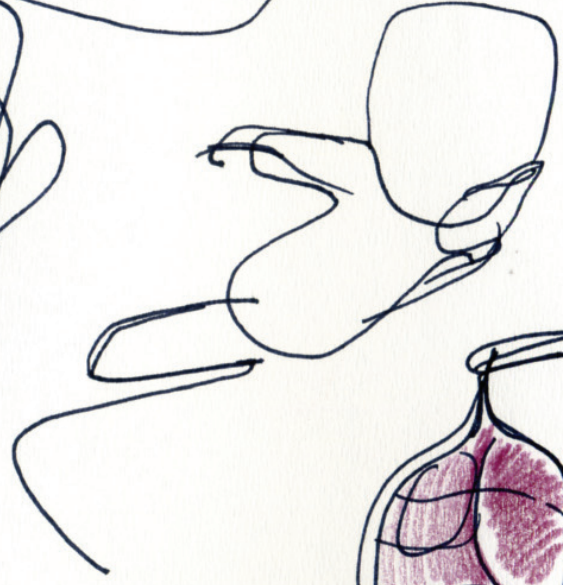
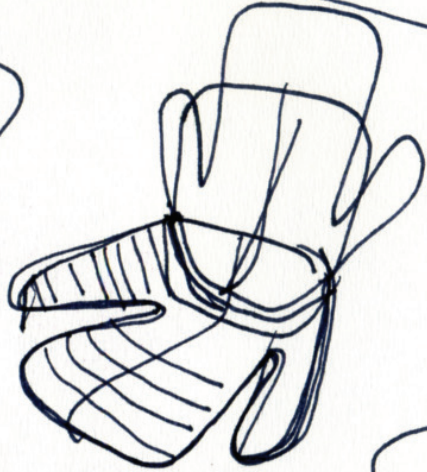
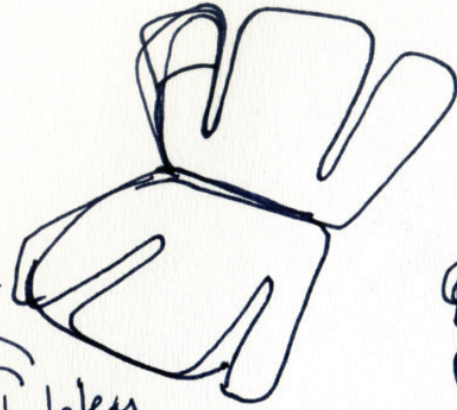

on a bean bag?

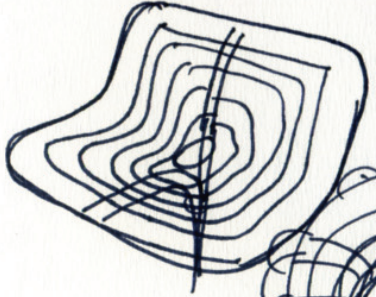

metal  
weave

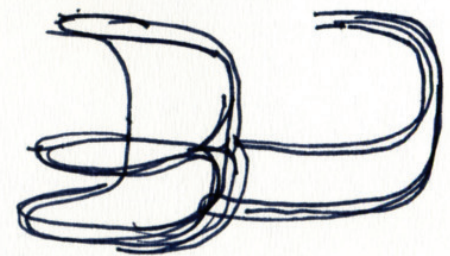
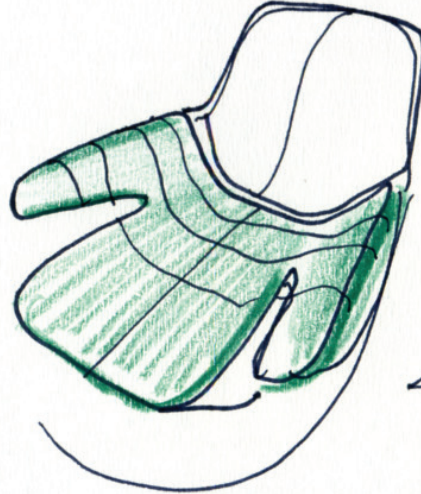
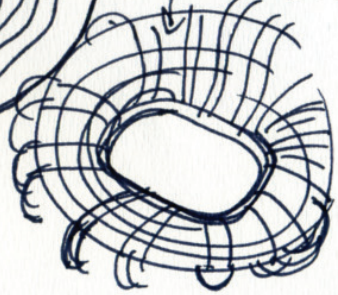

25 January 2010 © Jason Klenner

- 1. Spheres → idea.
- 2. book
- 3. carpet

Inspiration

Clever idea +  
Sculpture.

Poetic with practical indoor

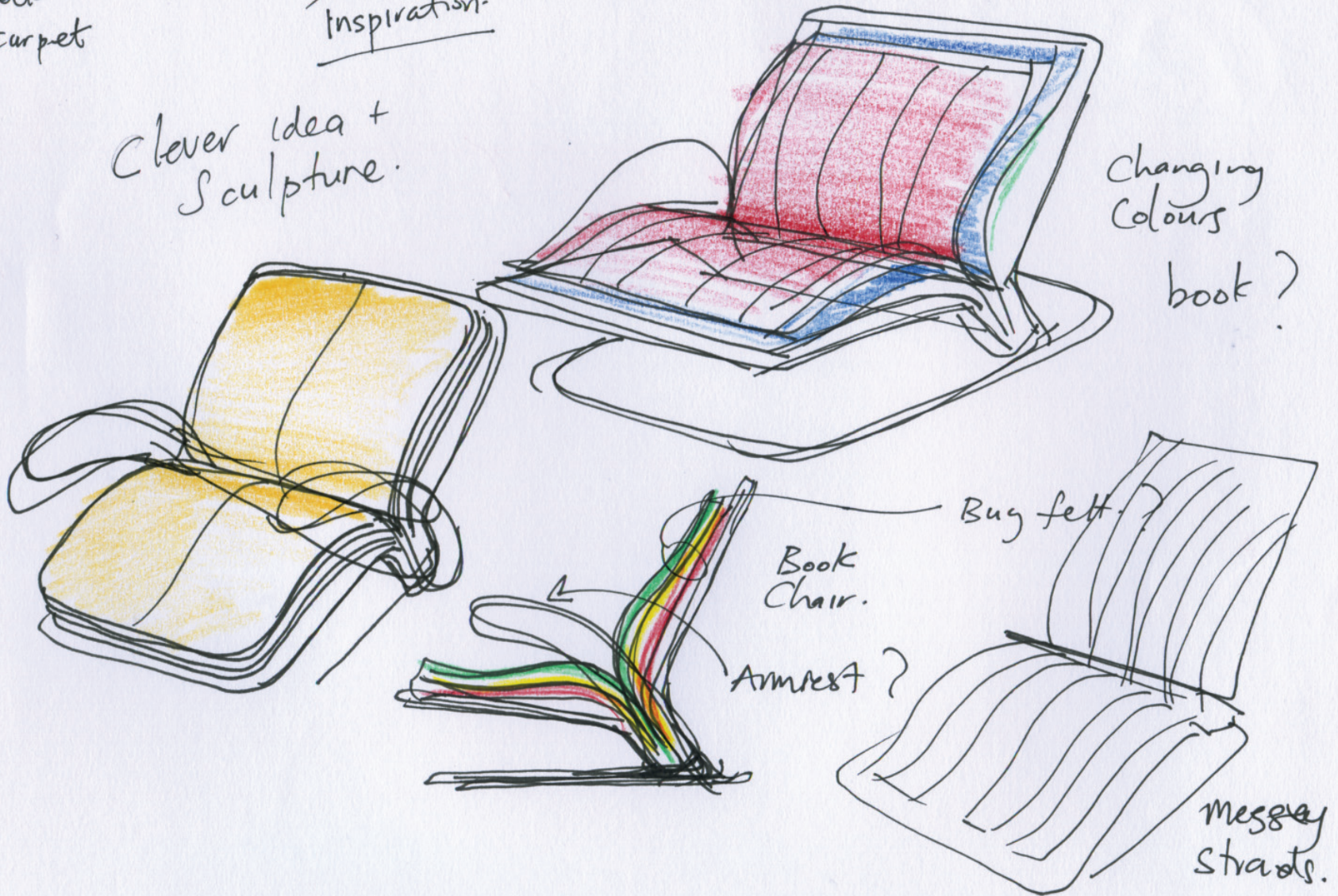

25 January 2010 © Jason Klenner

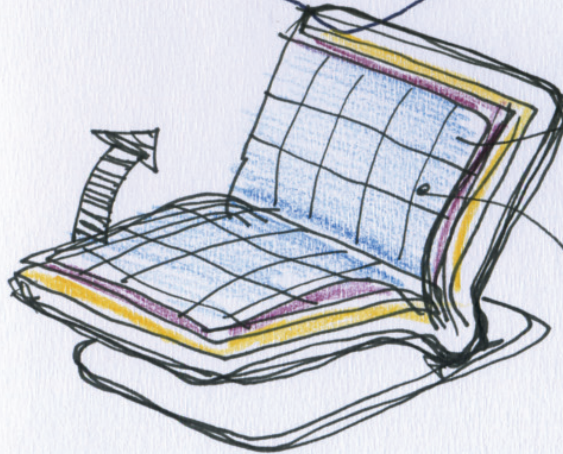
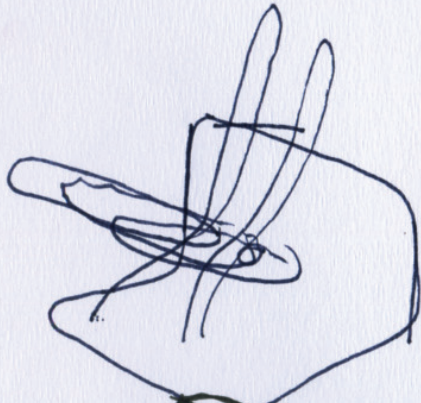
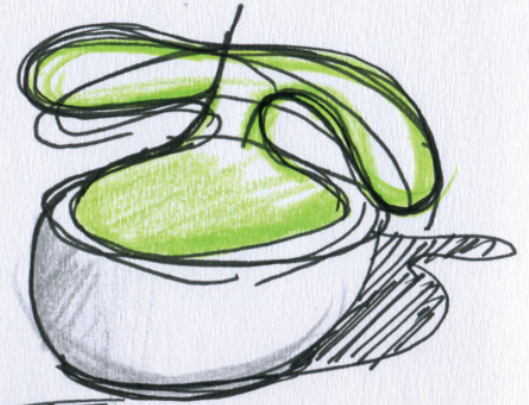
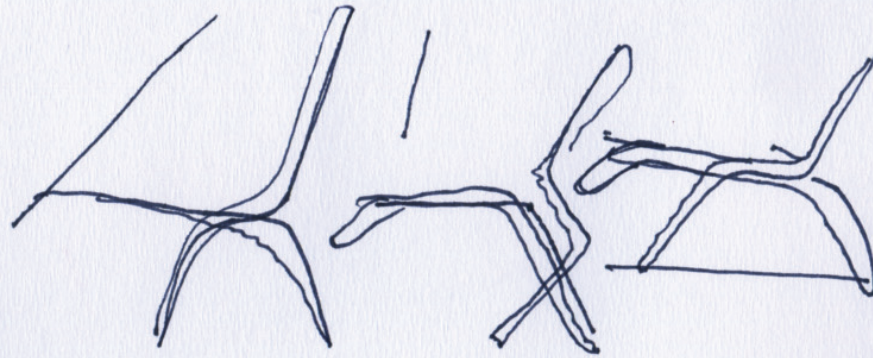

3D Laser cutting  
to create a flexible  
area of stainless  
steel tube

OR FELT?  
colour  
book

interchanging  
pages/colours.  
Mix and match for interiors?

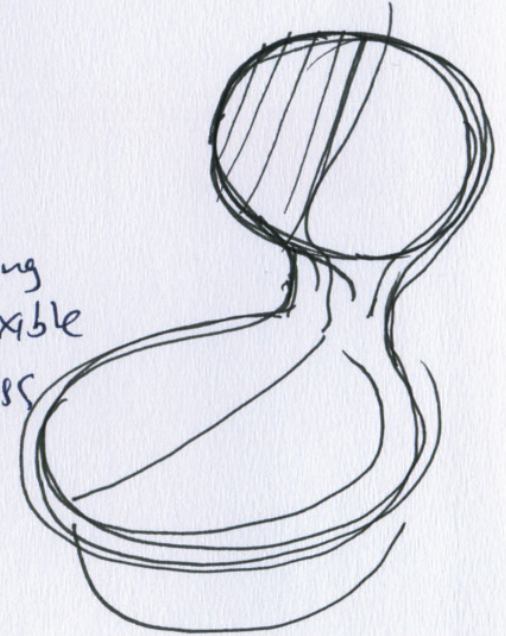

Sheets of Coloured foam (upholstered back)

Carved Slats.

Foam over tube  
Pipe cleaner chair.  
upholstered pipe.  
CNC Pipe bending

Mirror Surface

interlocking forms?

26 January 2010 © Jason Klenner

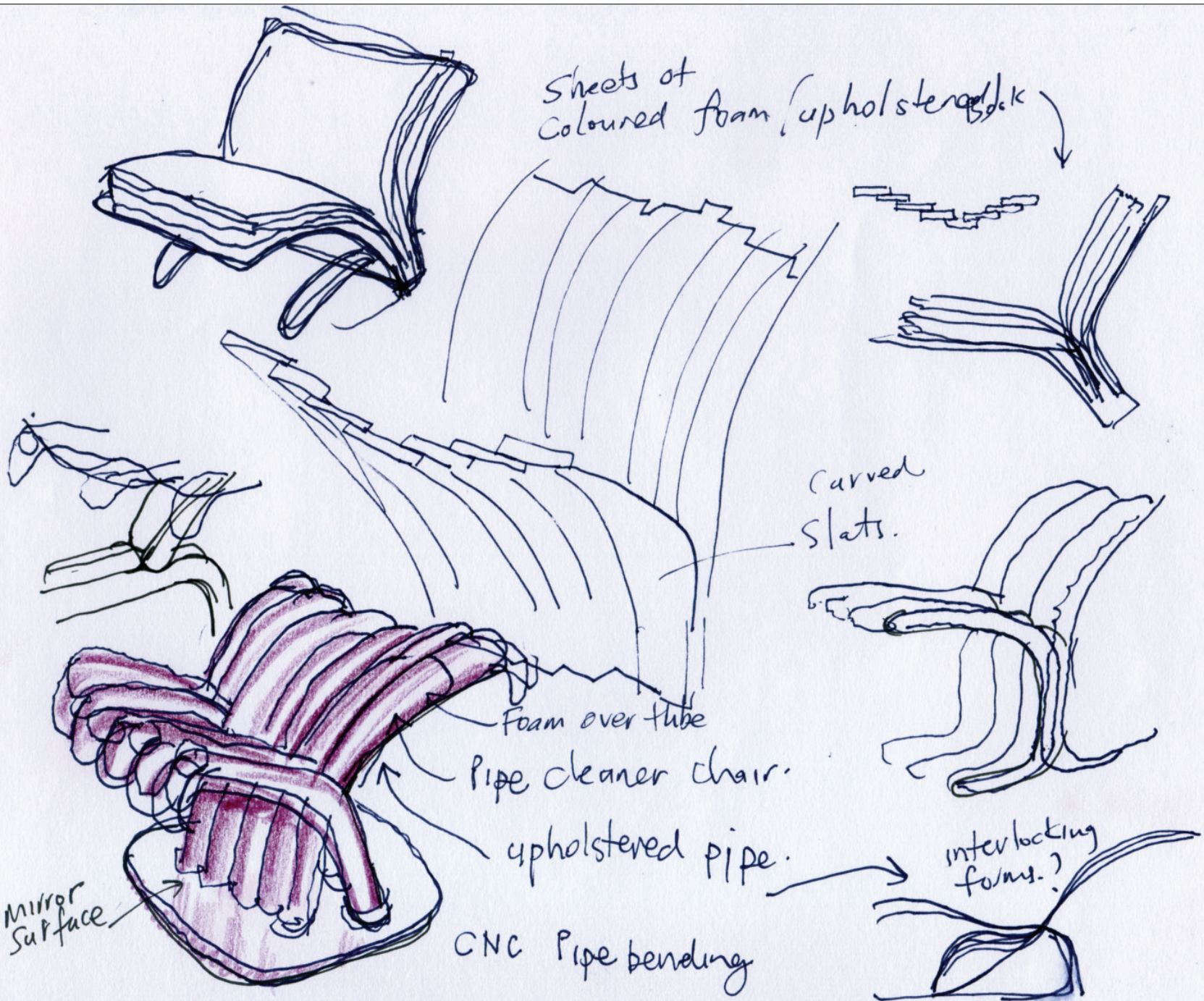

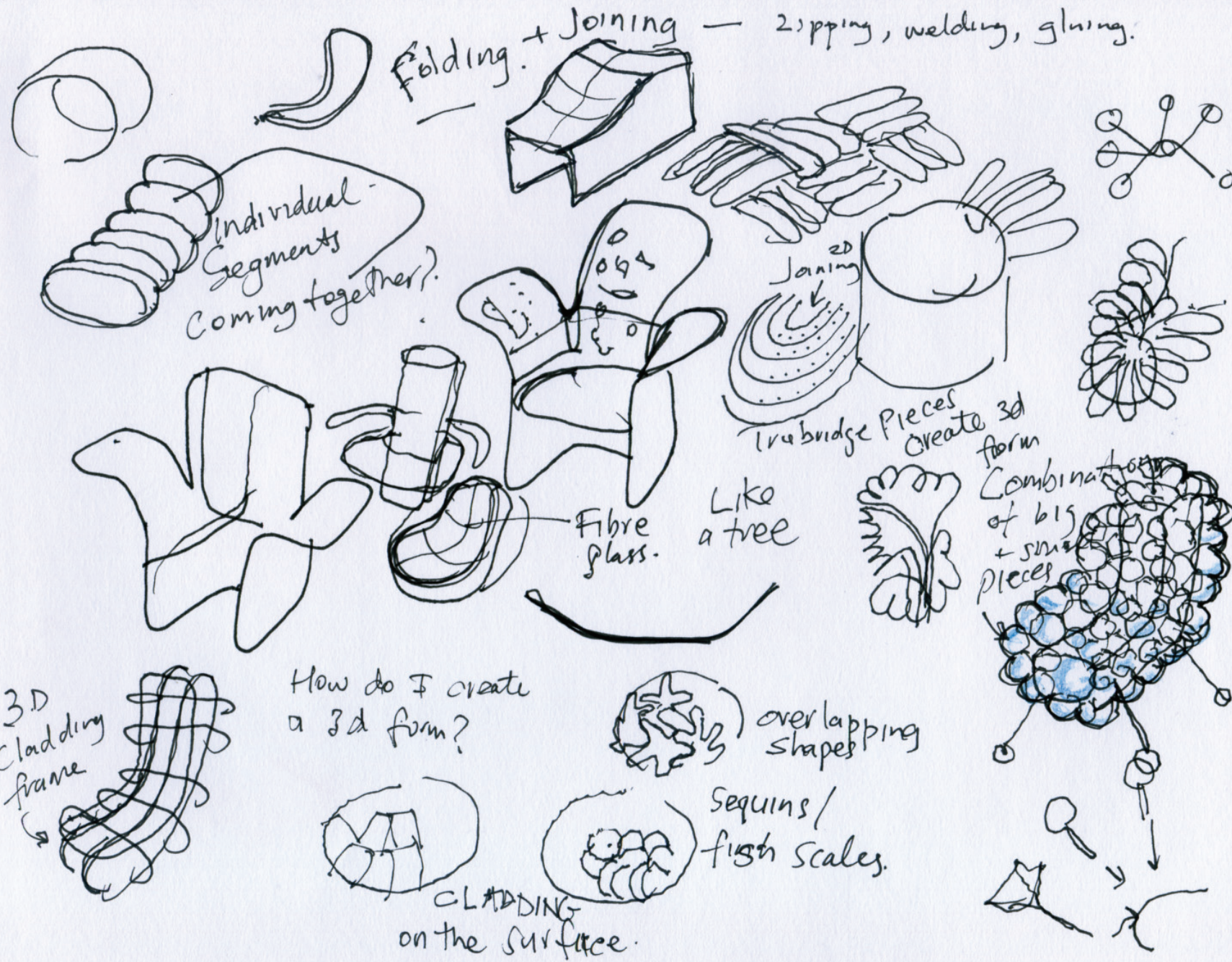

26 January 2010 © Jason Klenner

Break proportions by:

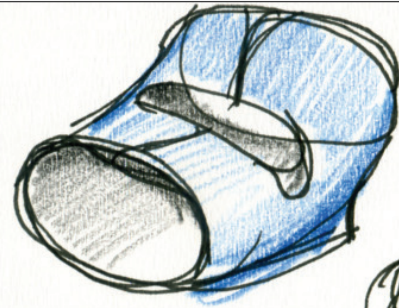

Structural  
carpet?

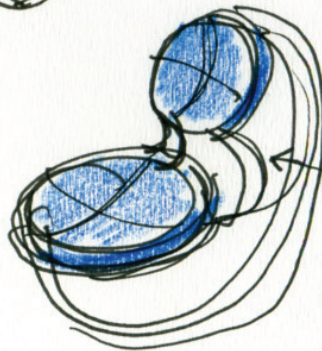
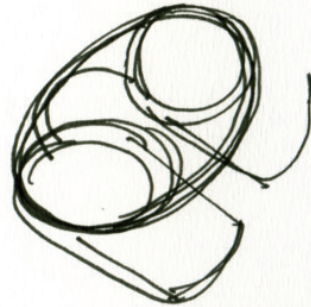
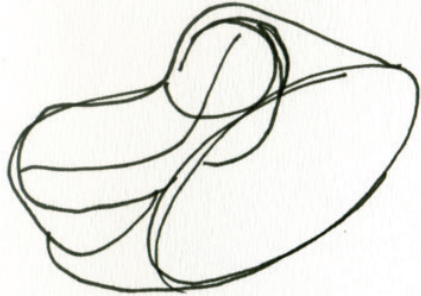
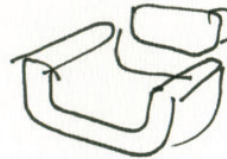
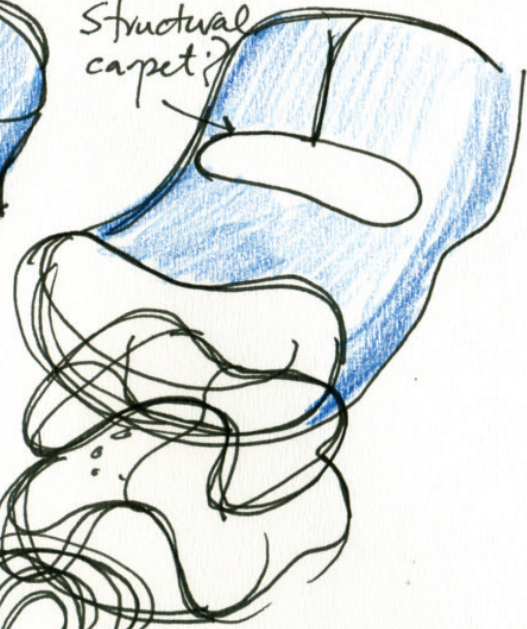

Too much  
Litce  
mark  
Newson?

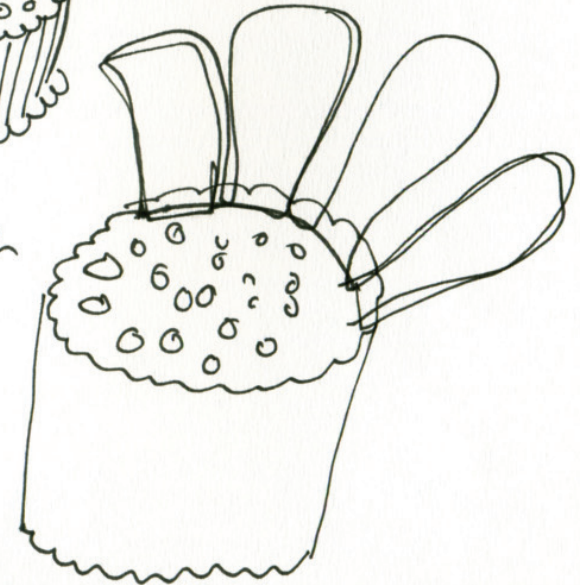

26 January 2010 © Jason Klenner

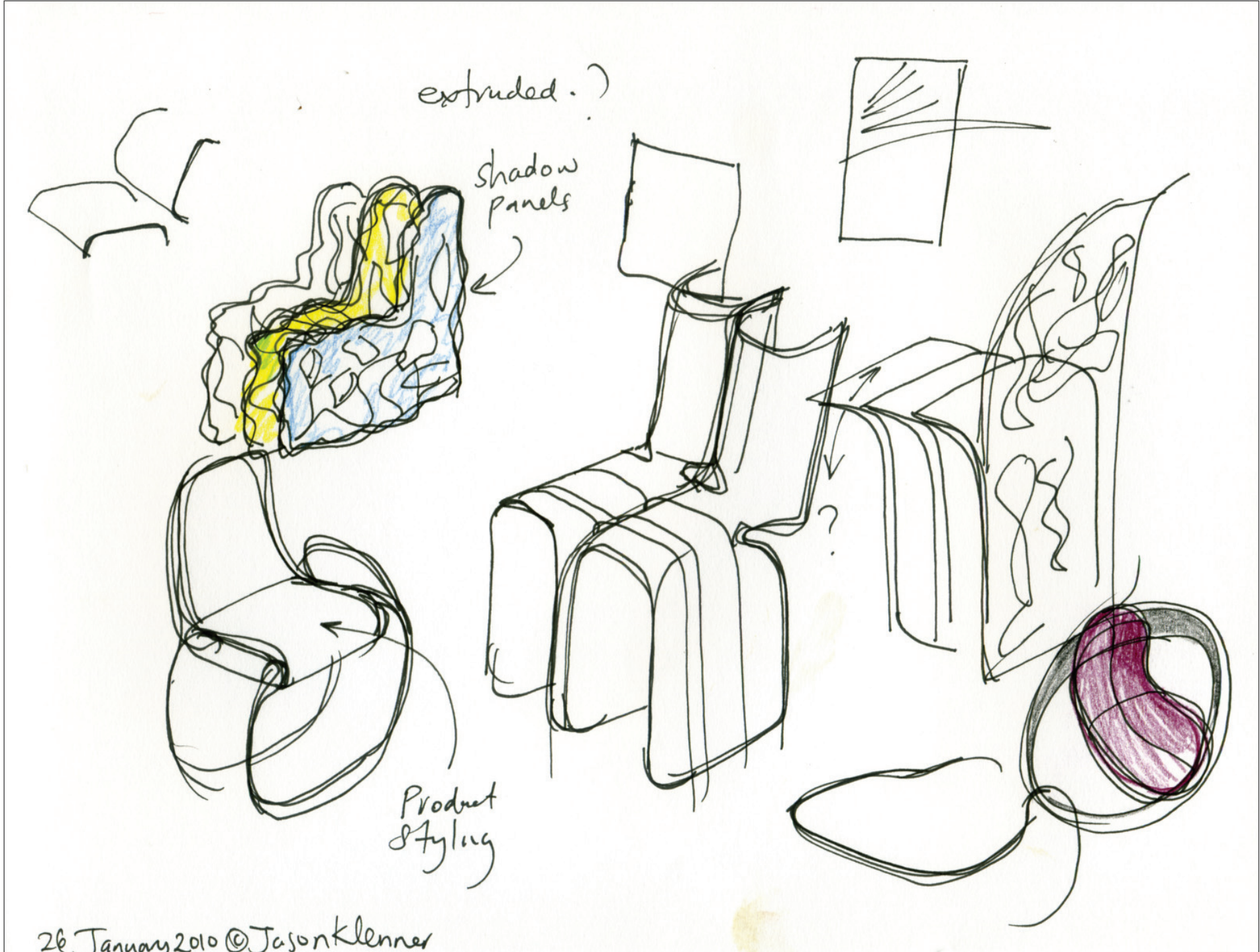

26 January 2010 © Jason Klenner

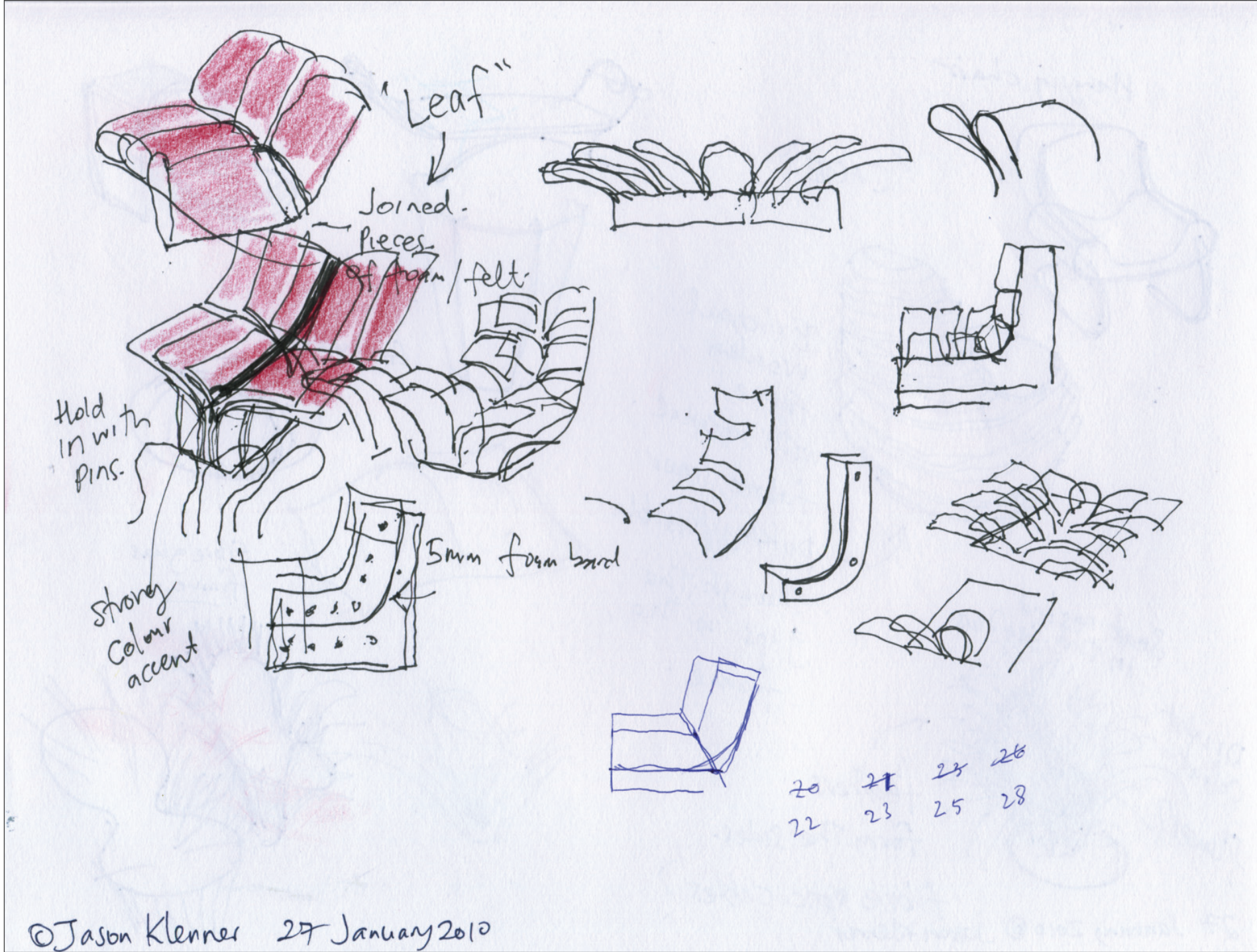

©Jason Klenner 27 January 2010

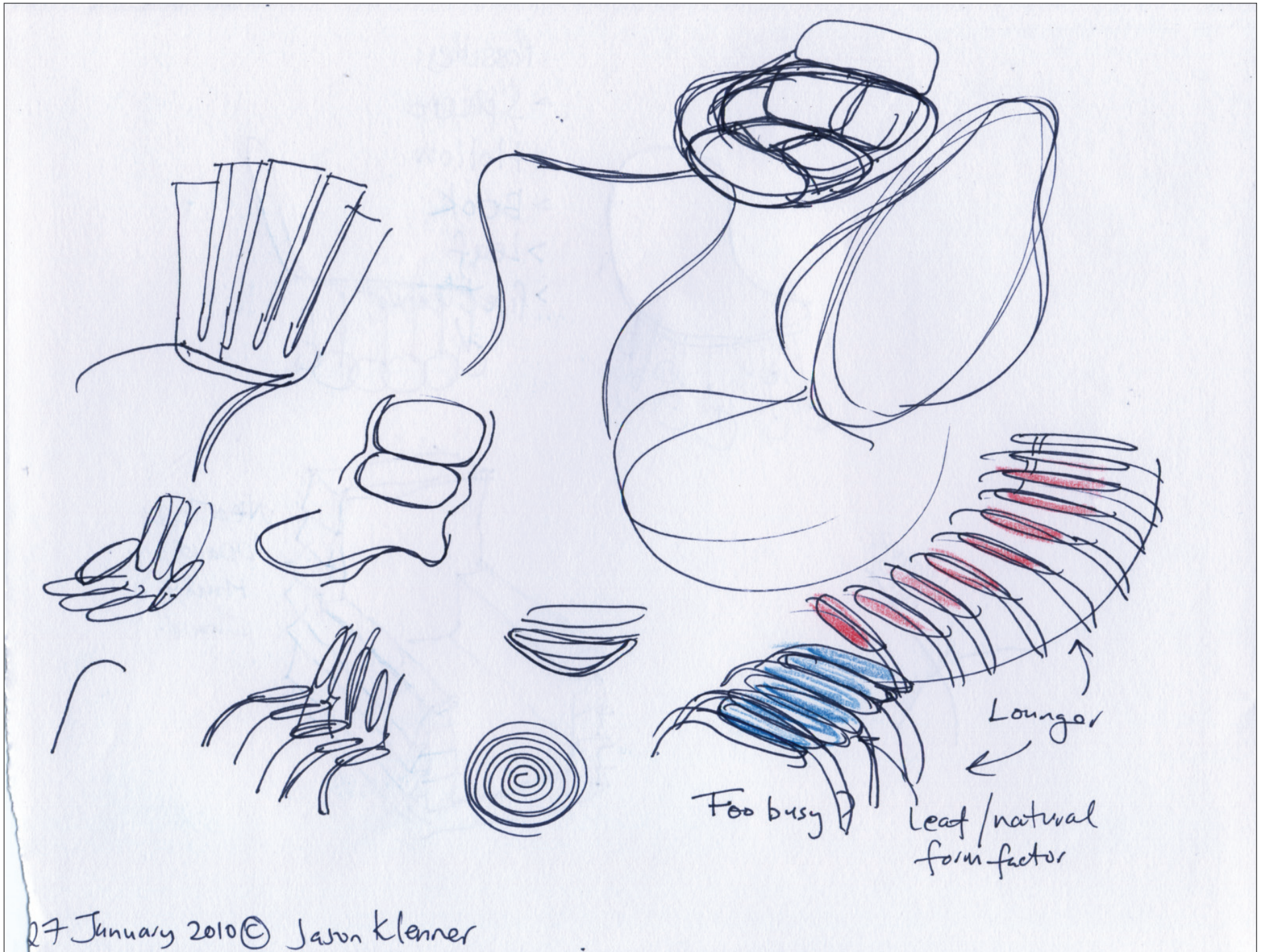

27 January 2010 © Jason Klenner

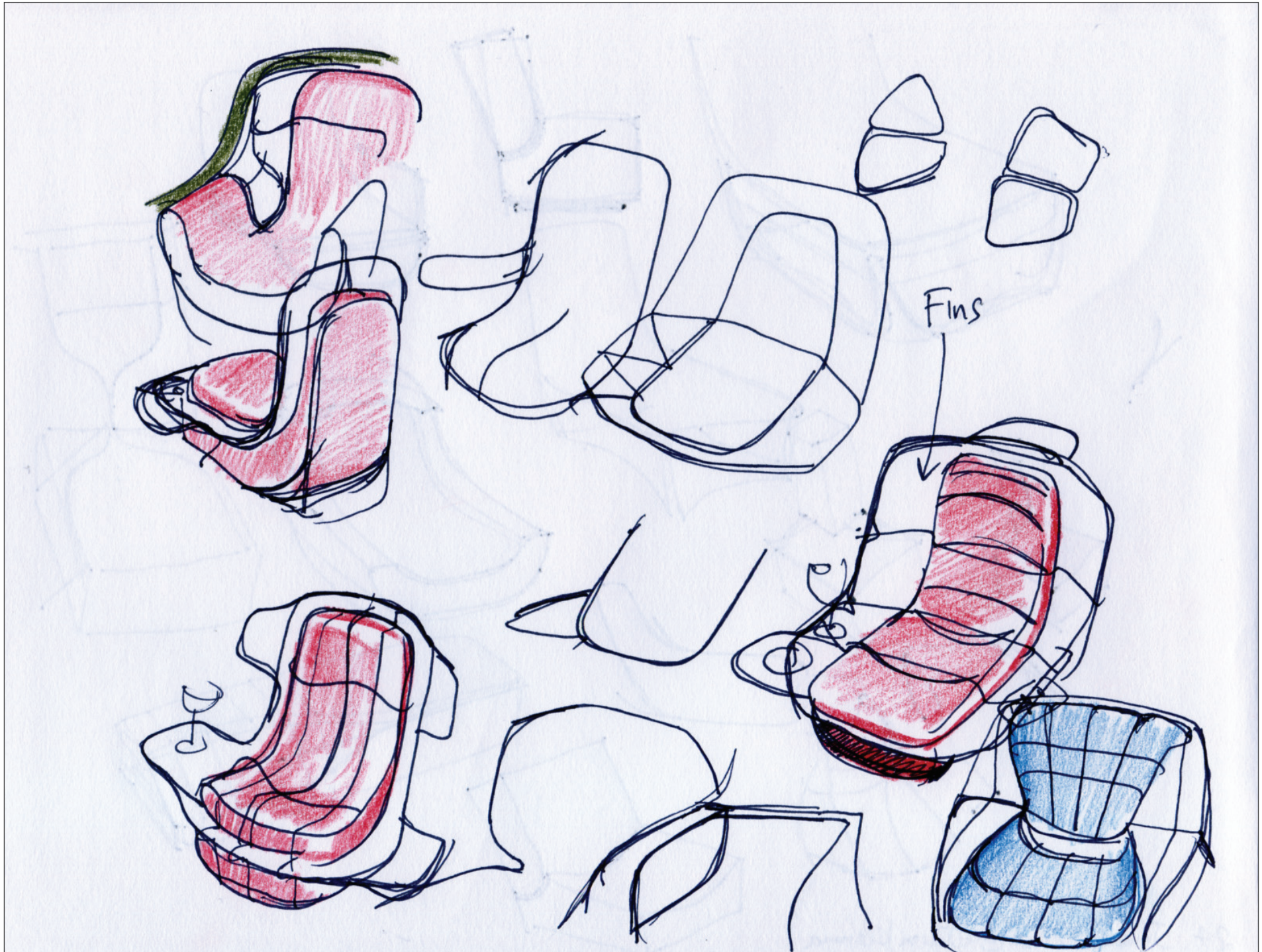

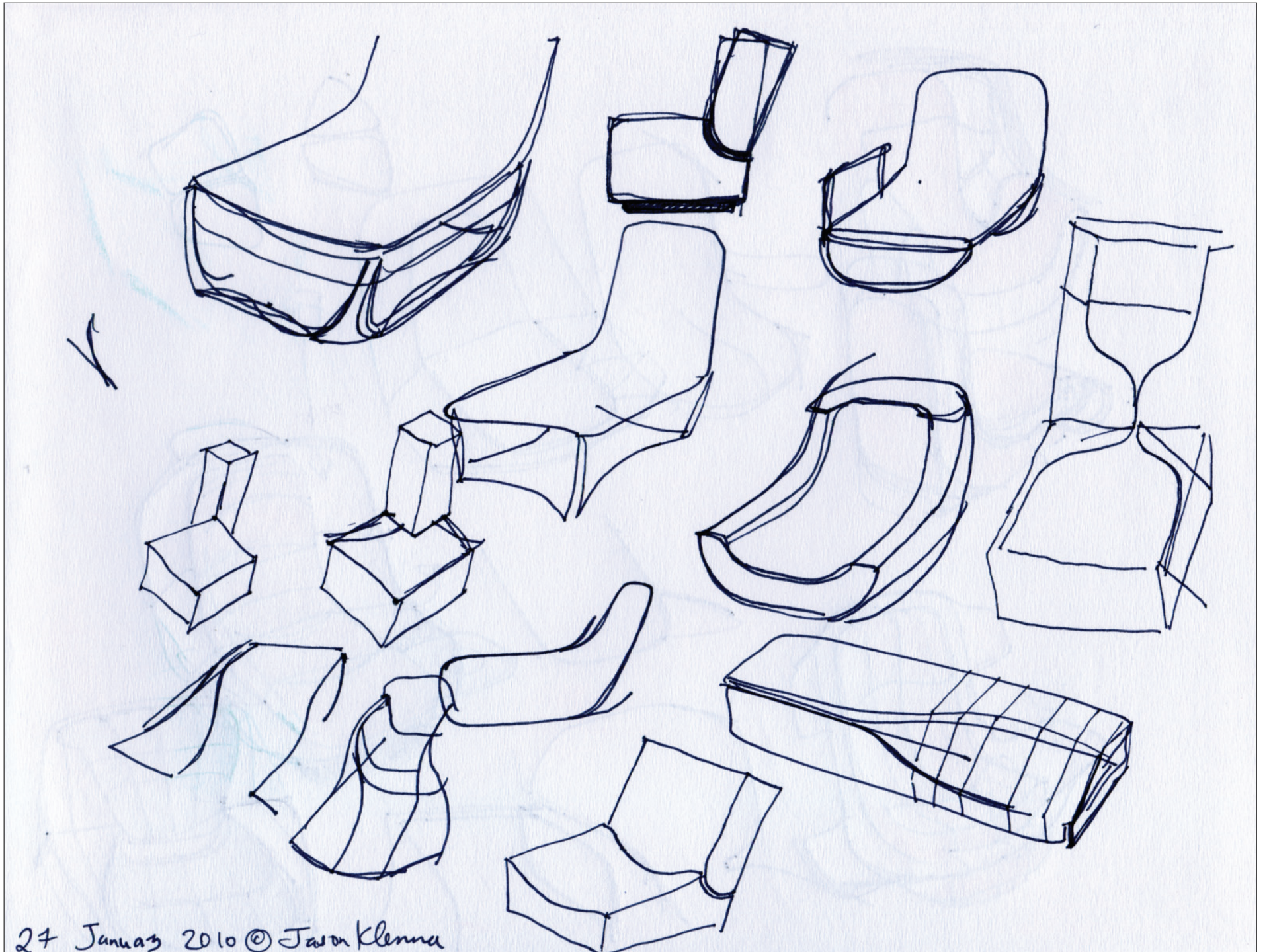

27 January 2010 © Jason Klenna

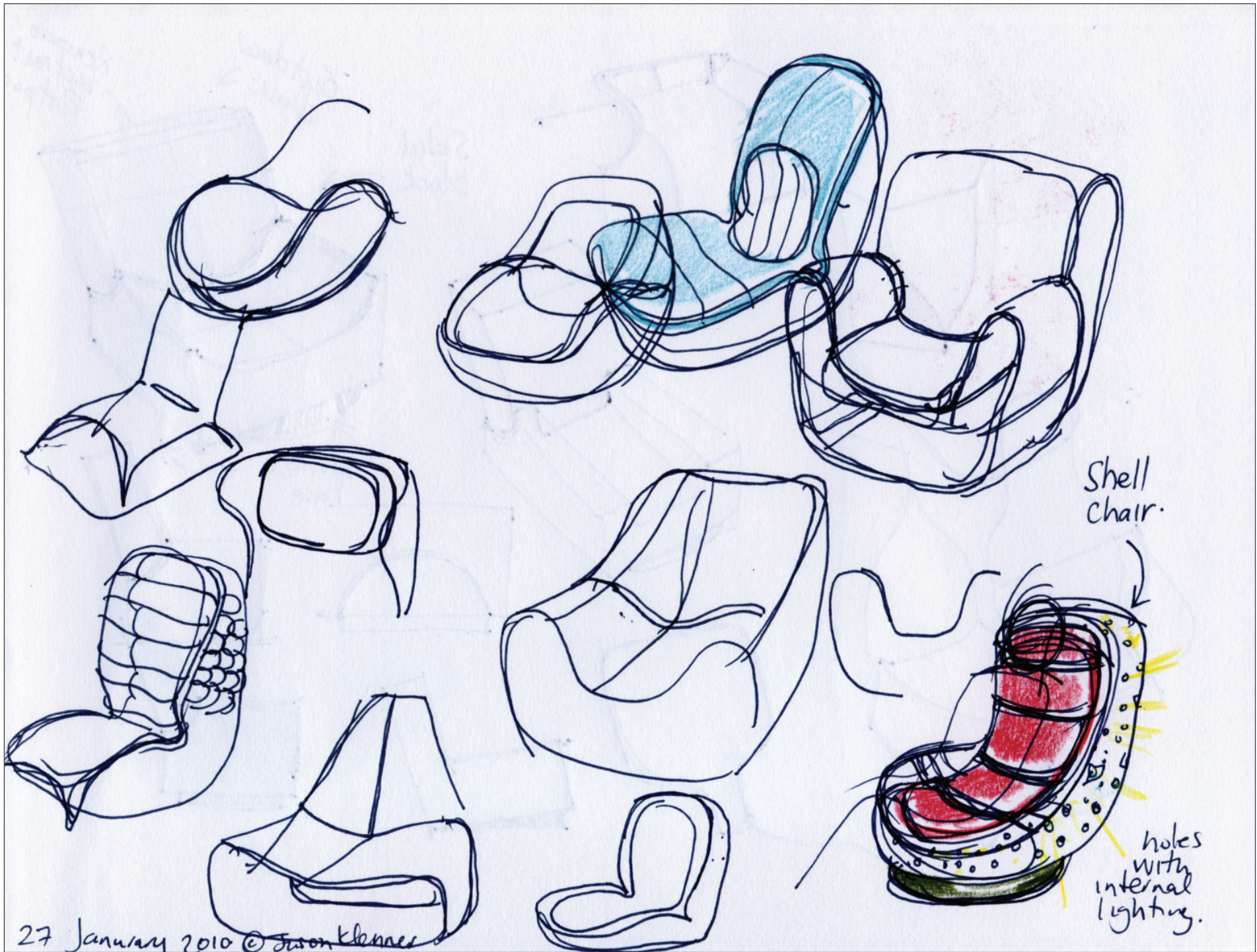

27 January 2010 © Jason Klenner

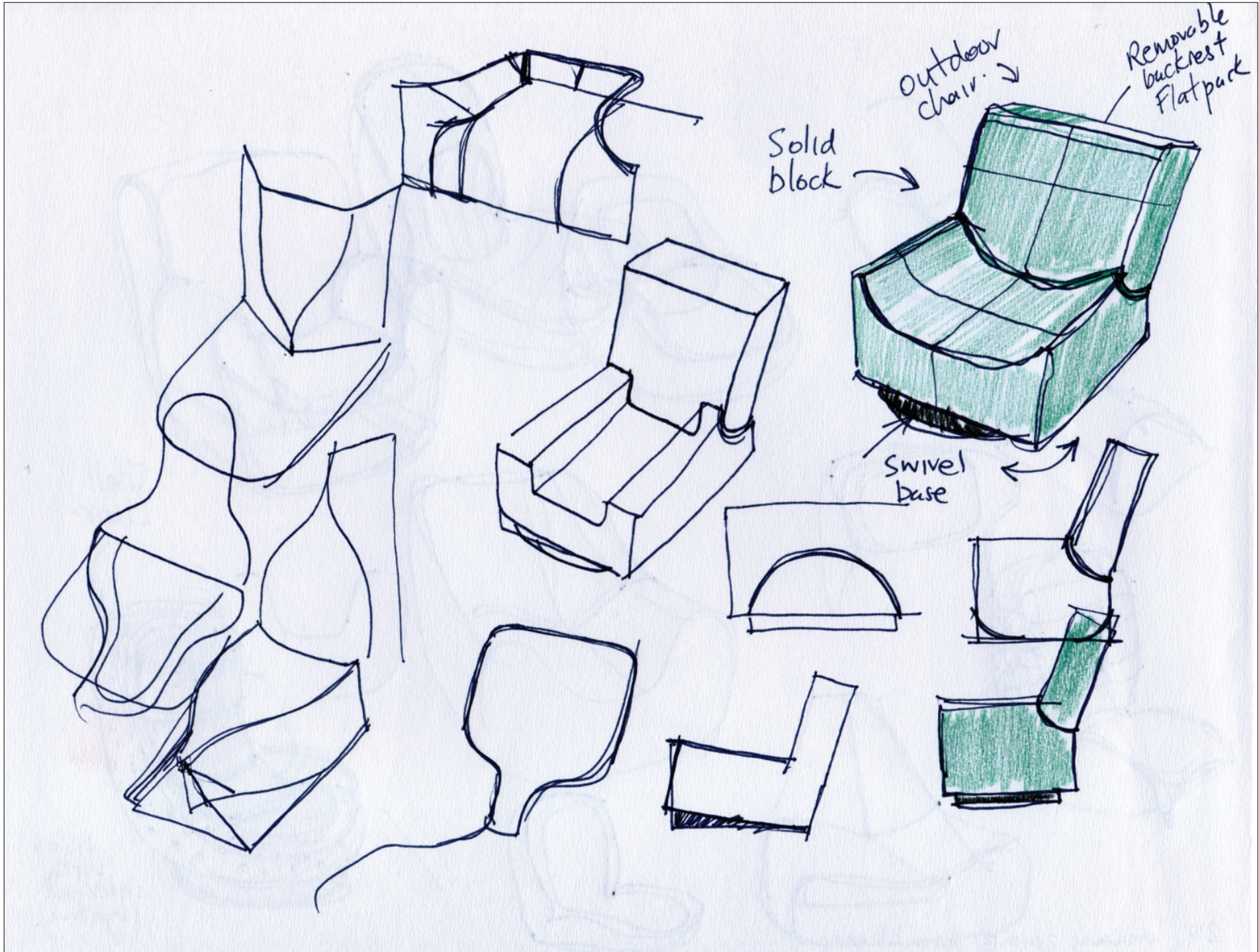

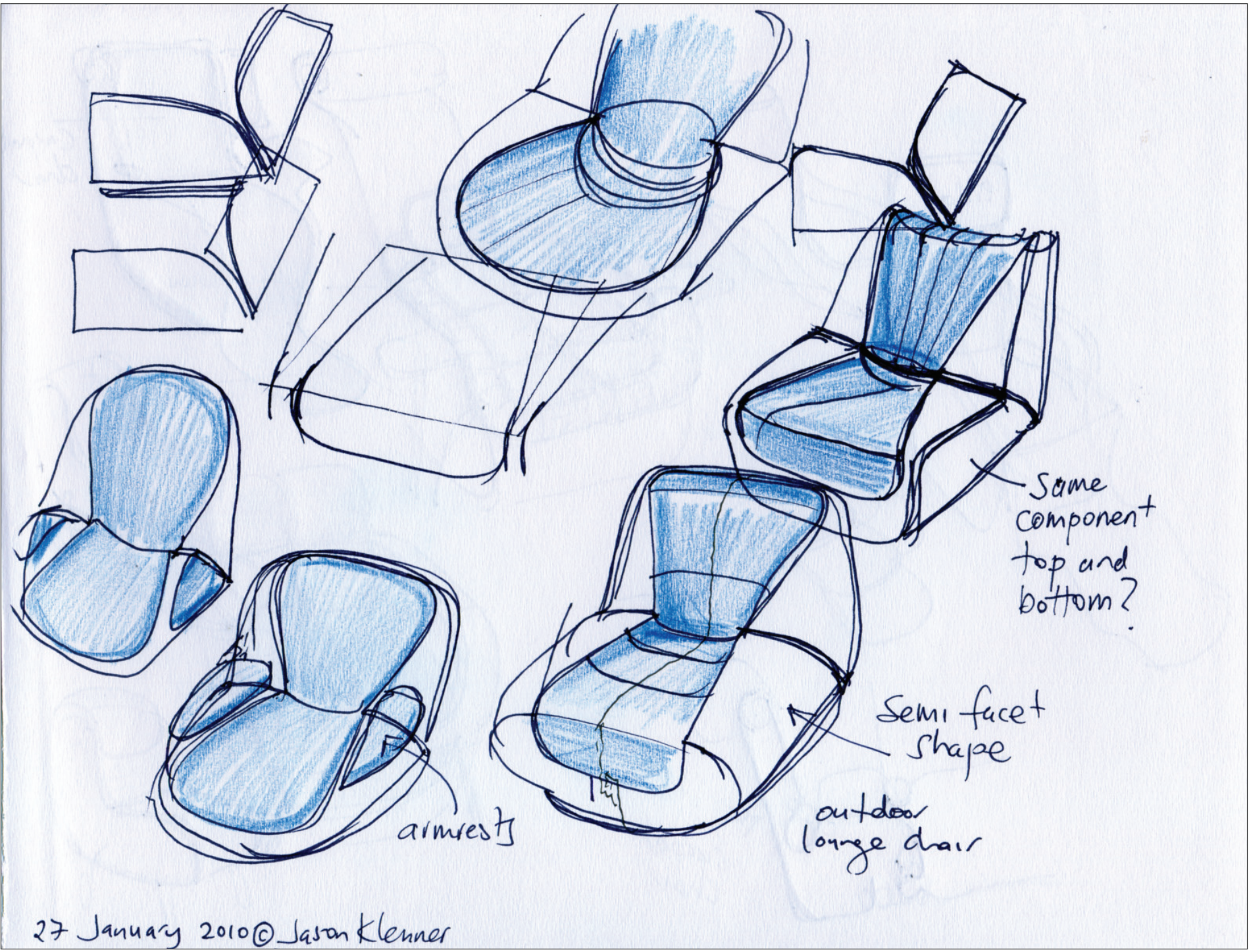

Some component top and bottom?

armrests

semi facet shape

outdoor lounge chair

27 January 2010 @ Jason Klenner

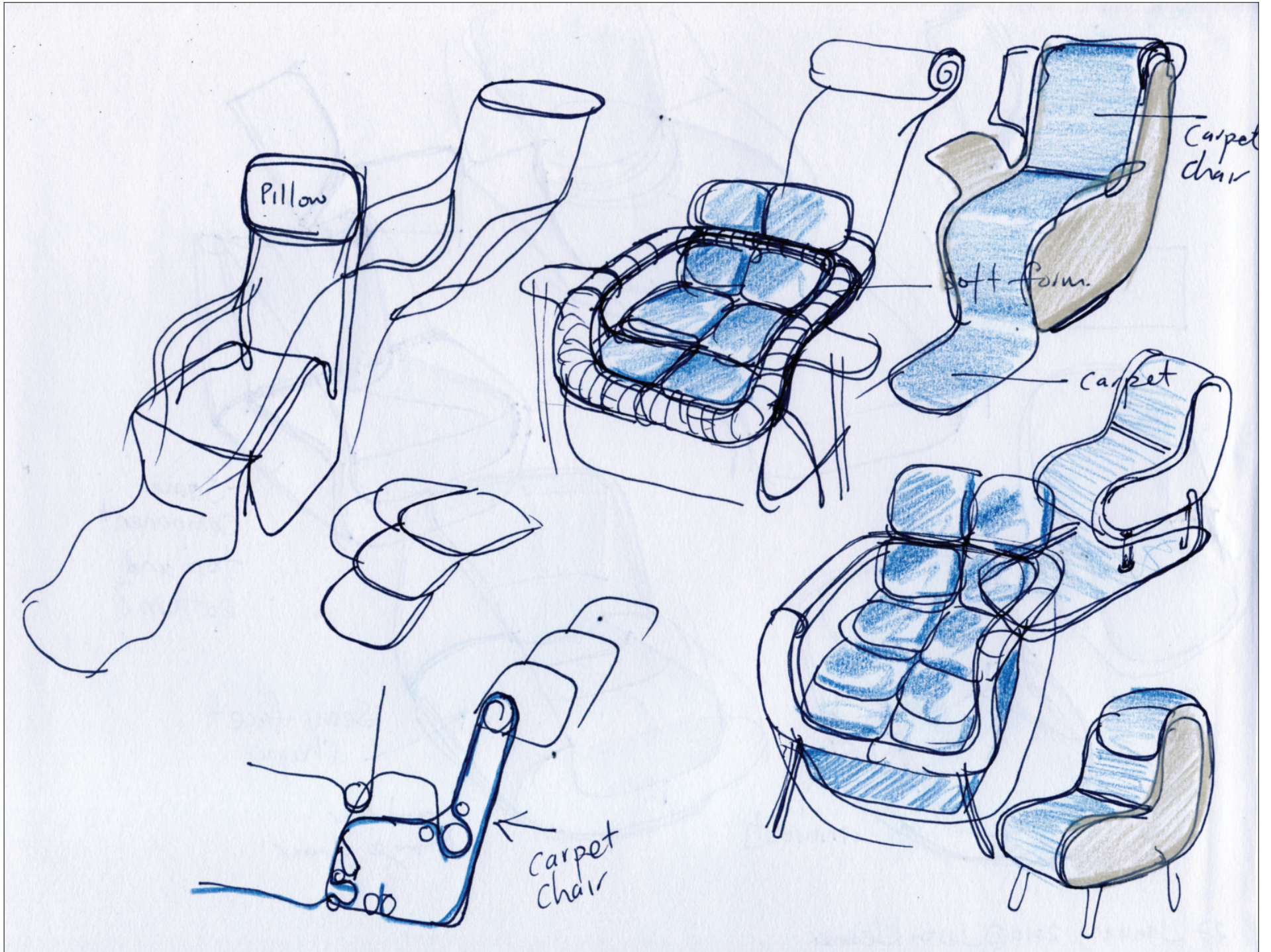

Hanging chair



"CAGE"

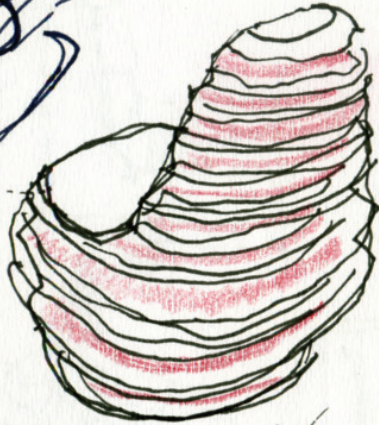
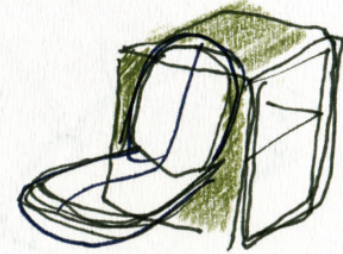

External  
Wooden  
Frame.  
with internal  
fabric liner  
poking/visible  
through the  
gaps in the  
frame.

Too  
Geometric.

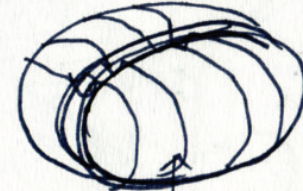

Fibre glass  
frame.



Seat rested  
in the feathers

bright  
colour?  
flower?



feathers.  
form the sides.

fibre optic cables?



27 January 2010 © Jason Klenner

Possibles:

- > Sphere
- > Hollow
- > Book
- > Leaf
- > Pipe cleaner

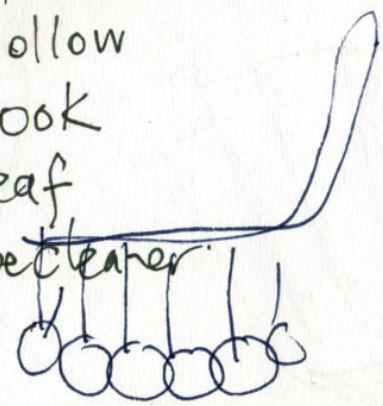
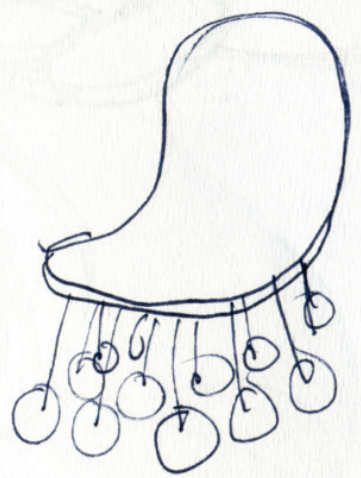

Mean here

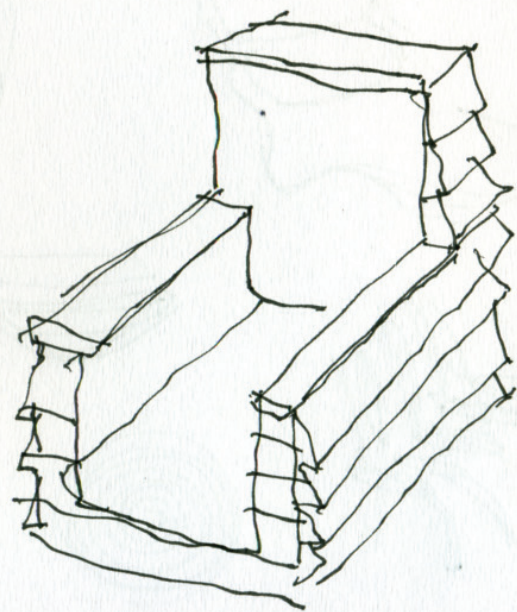

Weather board  
House  
Chair.

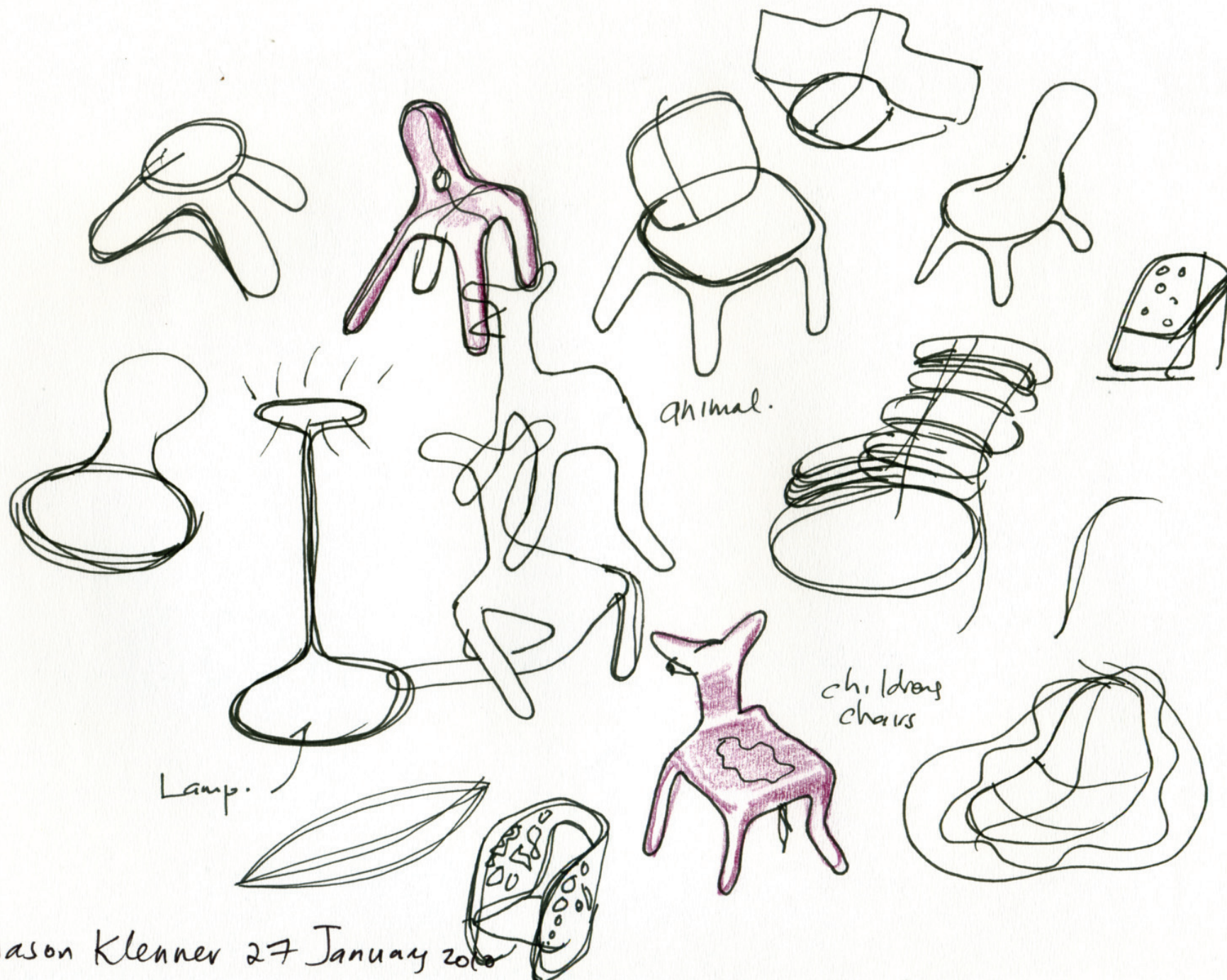

© Jason Klenner 27 January 2010

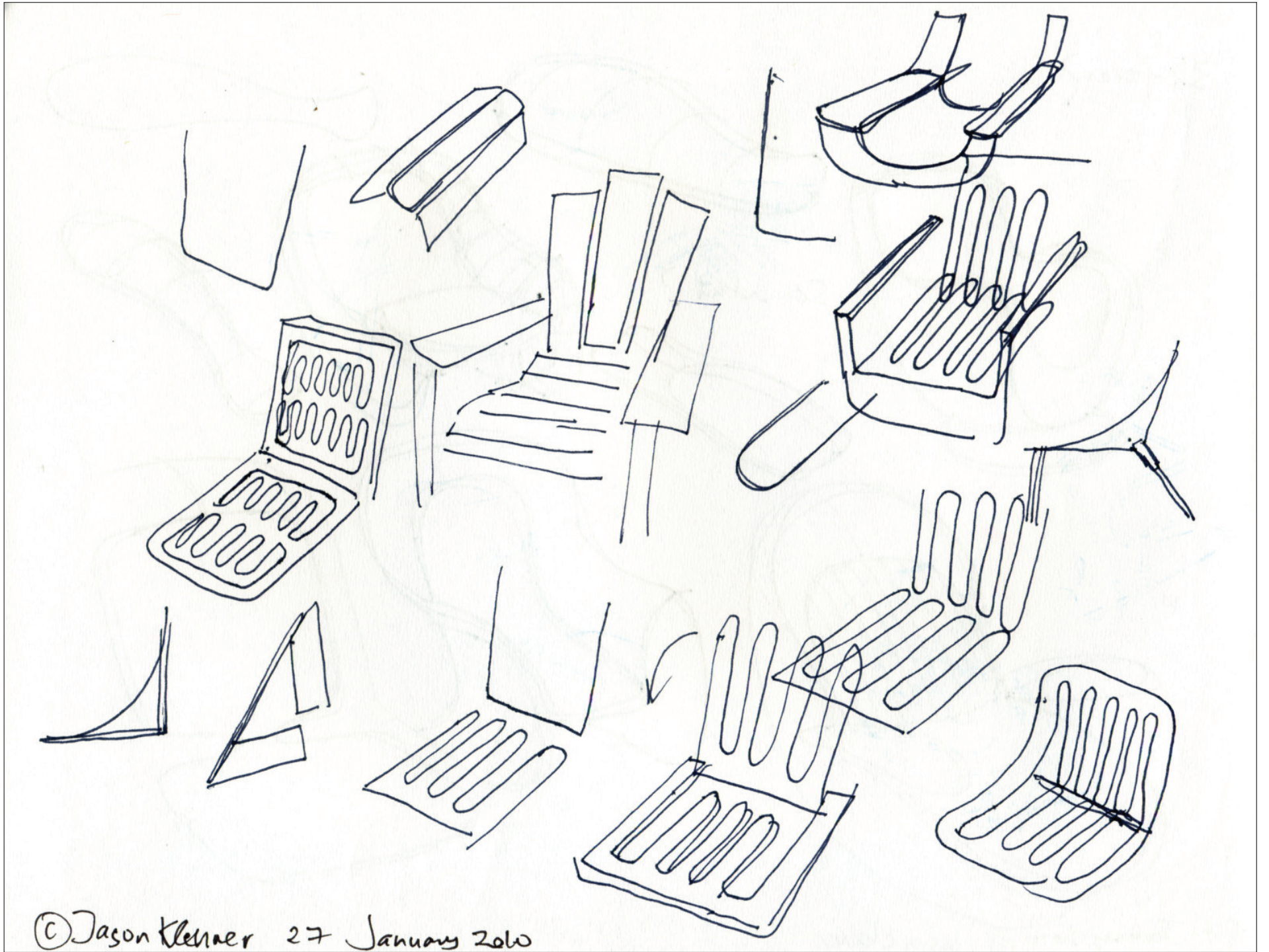

© Jason Klehaer 27 January 2010

3D form?

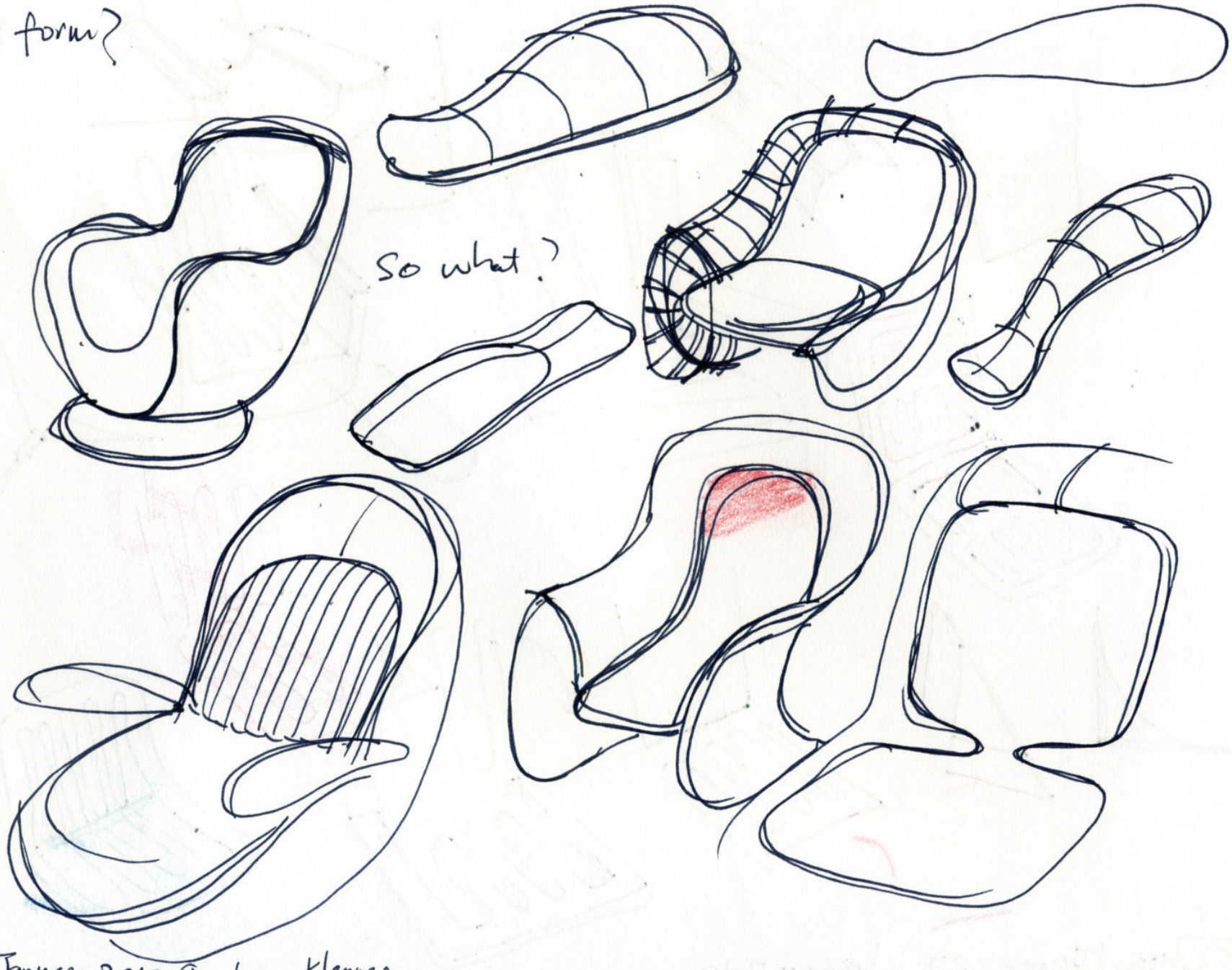

So what?

27 January 2010 @ Jason Klenner

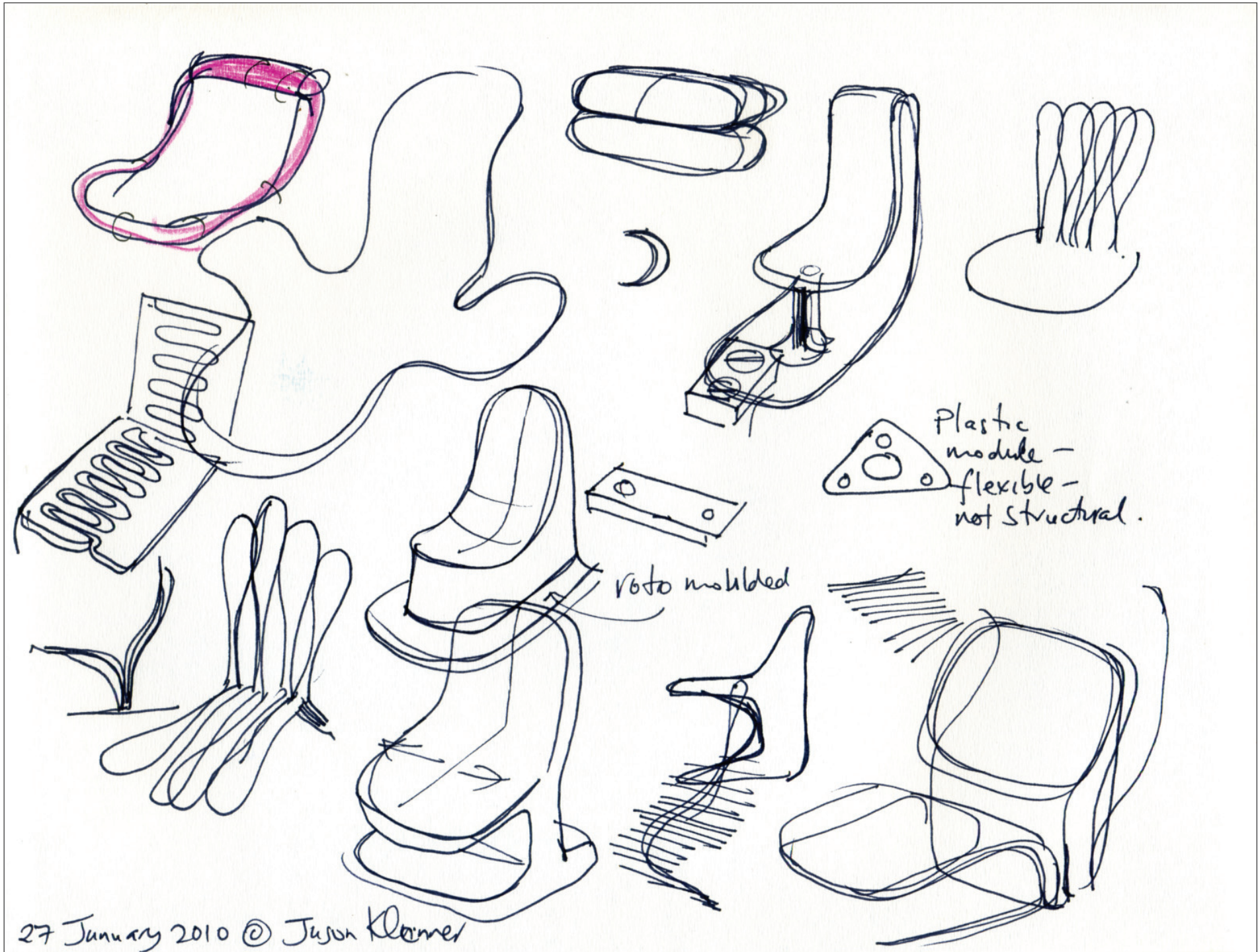

27 January 2010 © Jason Klamer

Carpet  
strips

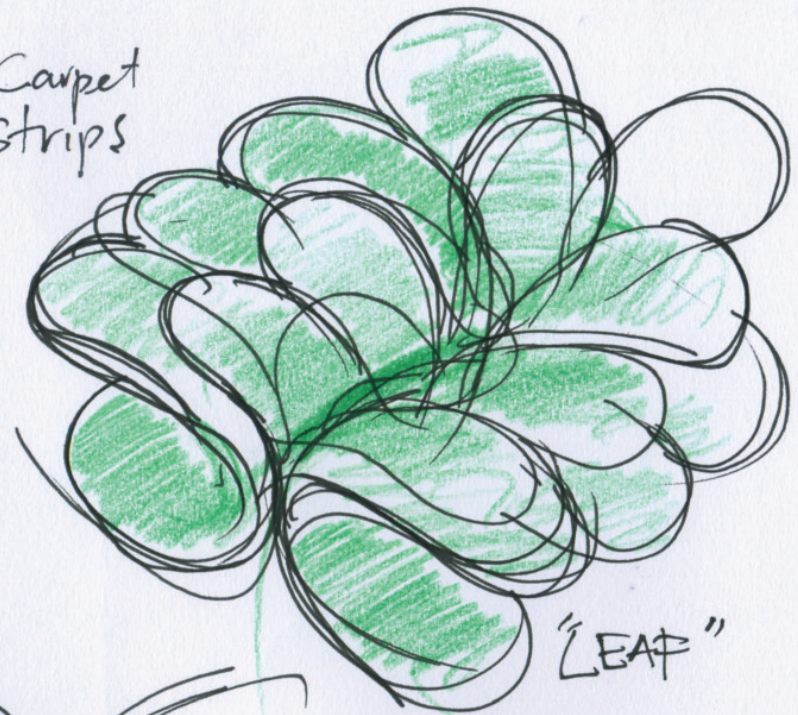

"LEAF"

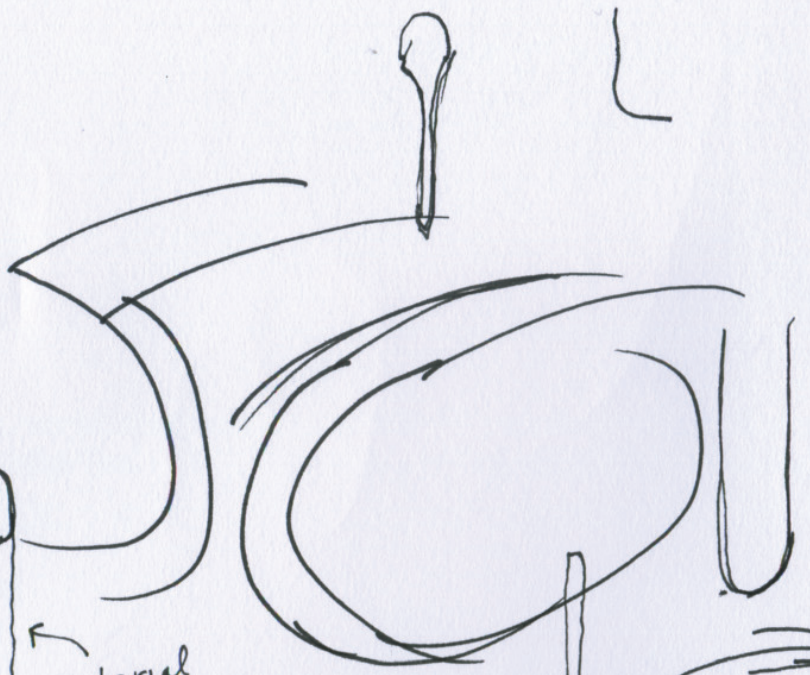

Material  
usage?

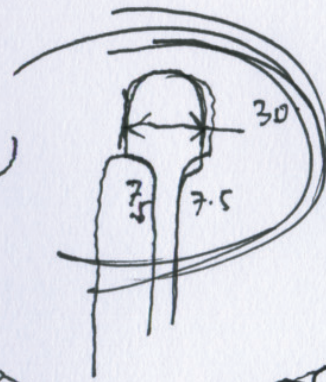

Bent and  
covered in felt

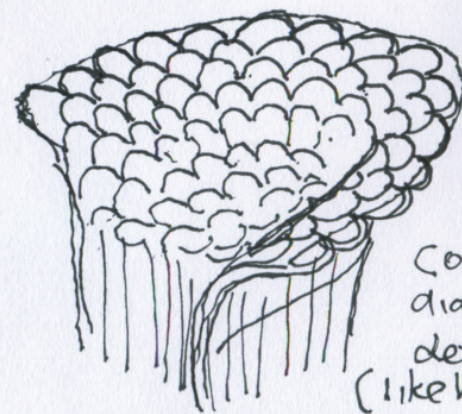
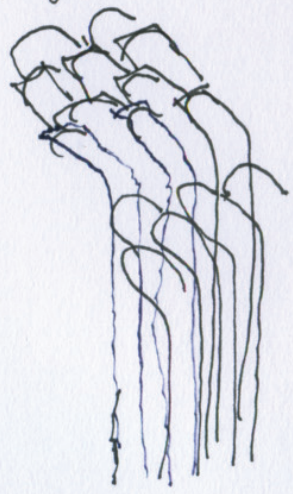

Cool  
diagonal  
detail.  
(like honey comb)



4 February 2010 © Jason Klenner

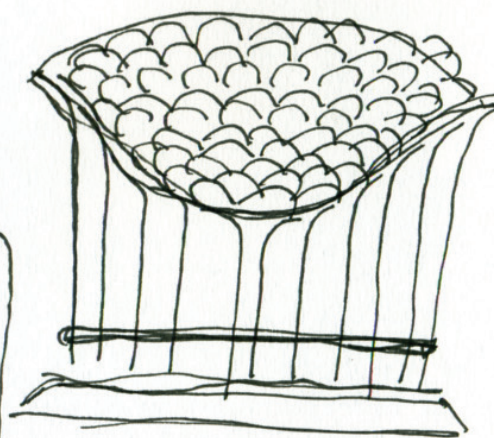
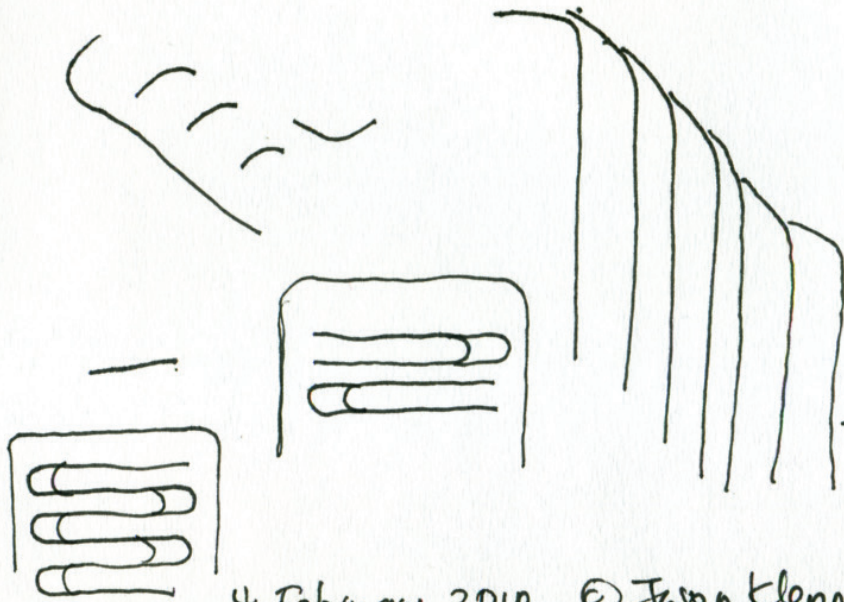
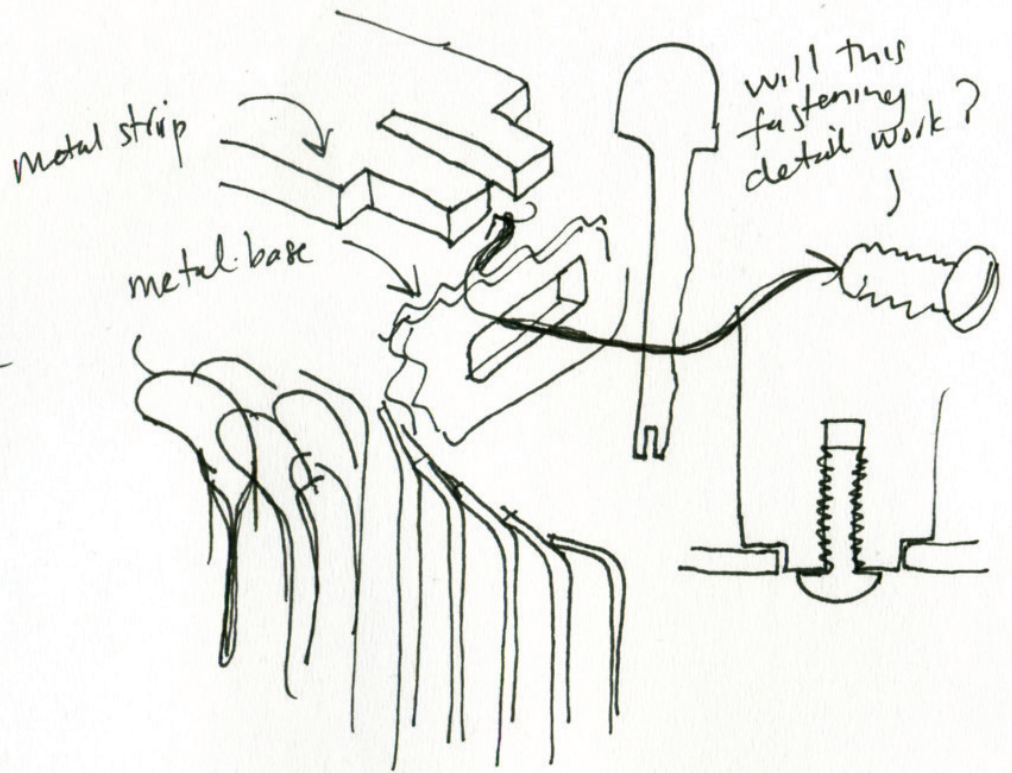
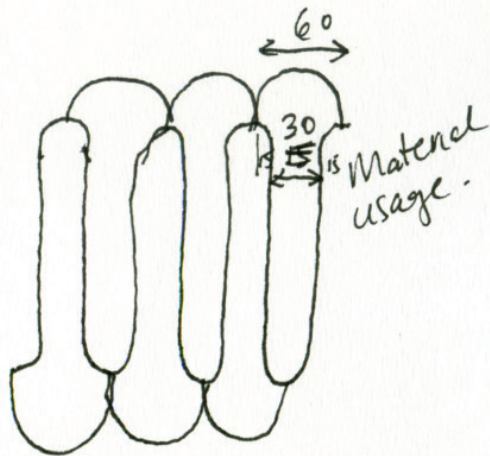

Bent metal strips  
joined together  
to form a solid  
flowing object

4 February 2010 © Jason Klenner

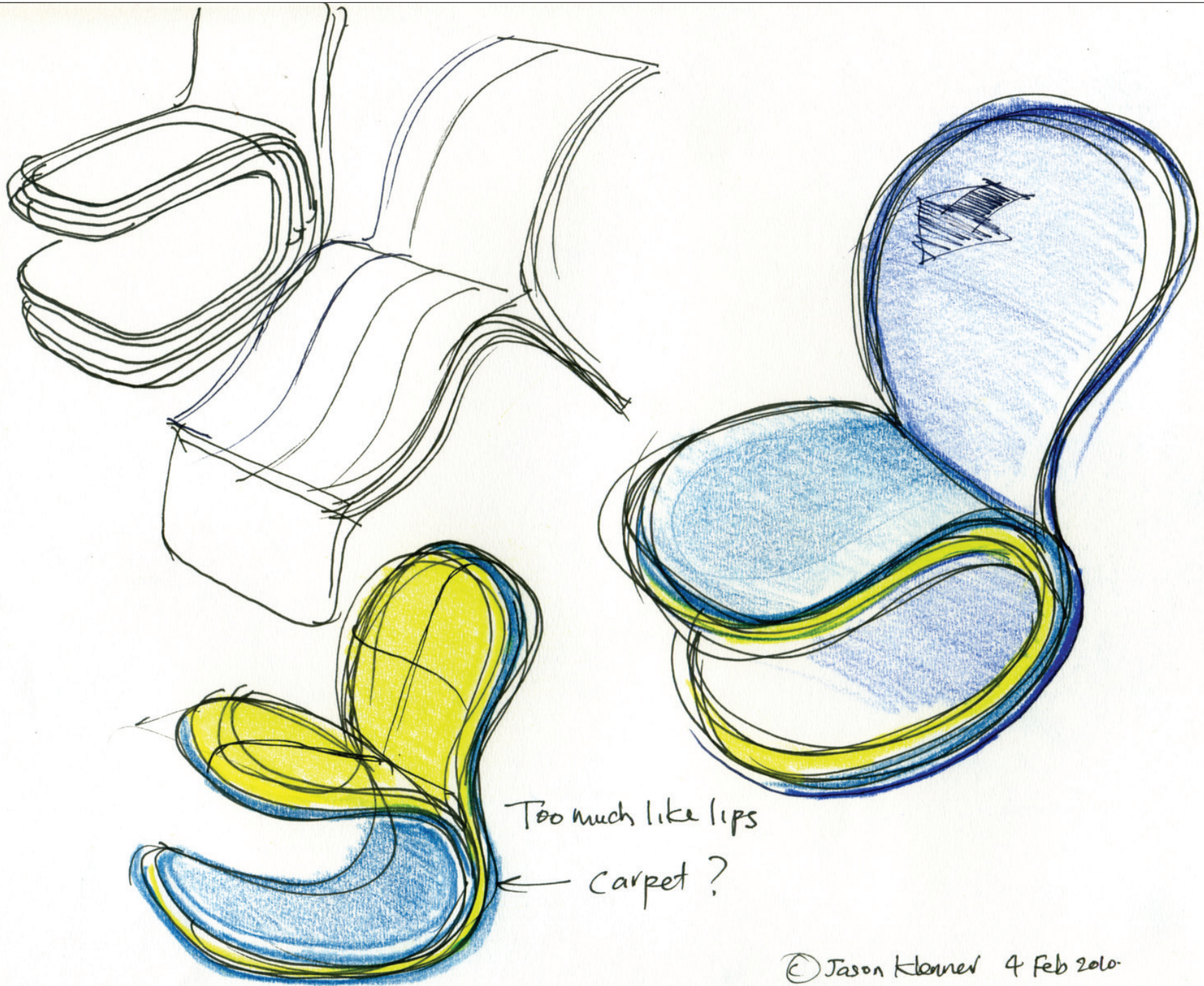

Too much like lips

← Carpet ?

© Jason Klanner 4 Feb 2010

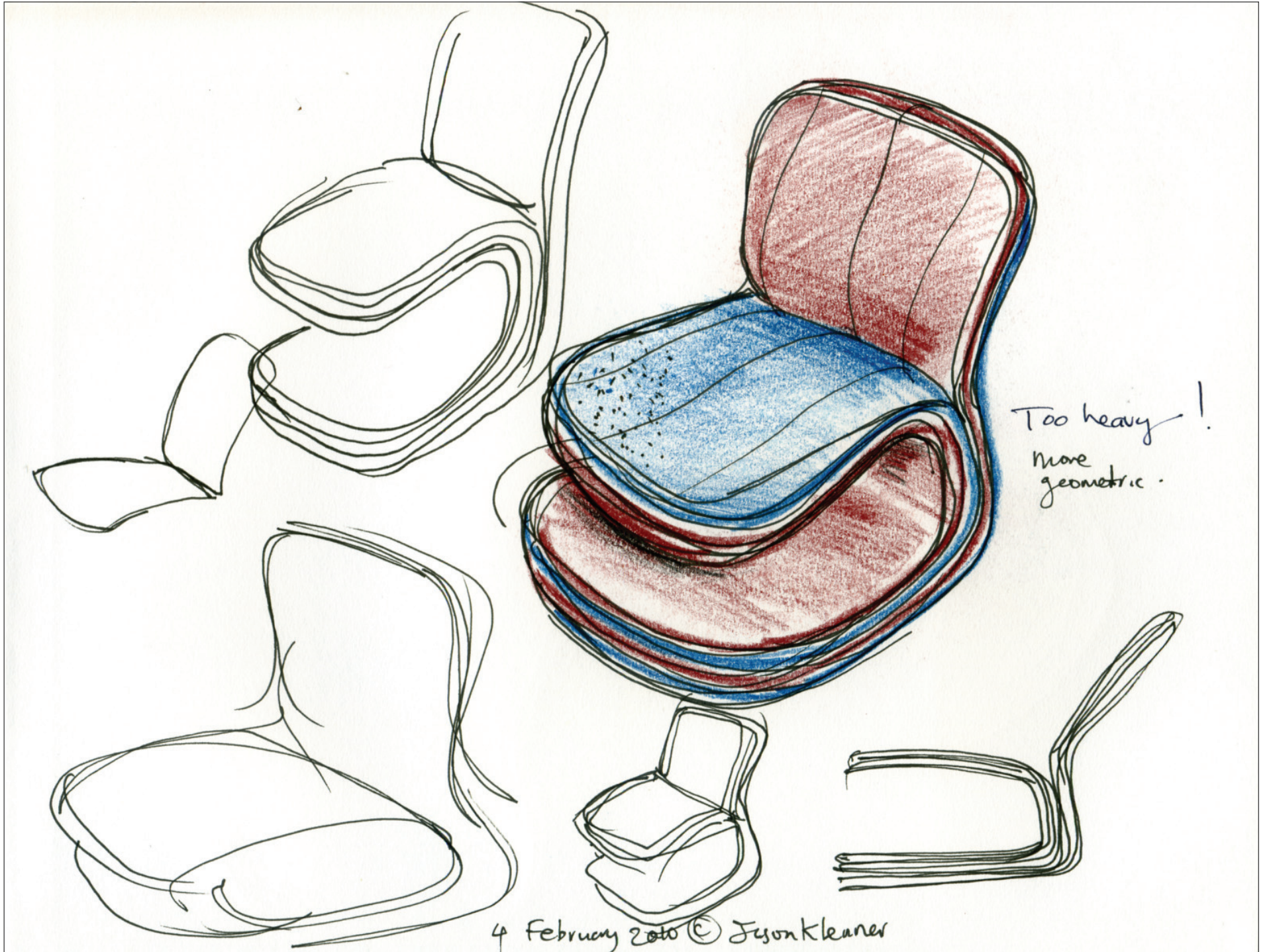

Too heavy!  
more  
geometric.

4 February 2010 © Jason Kleener



4 February 2016 © Jason Klenner

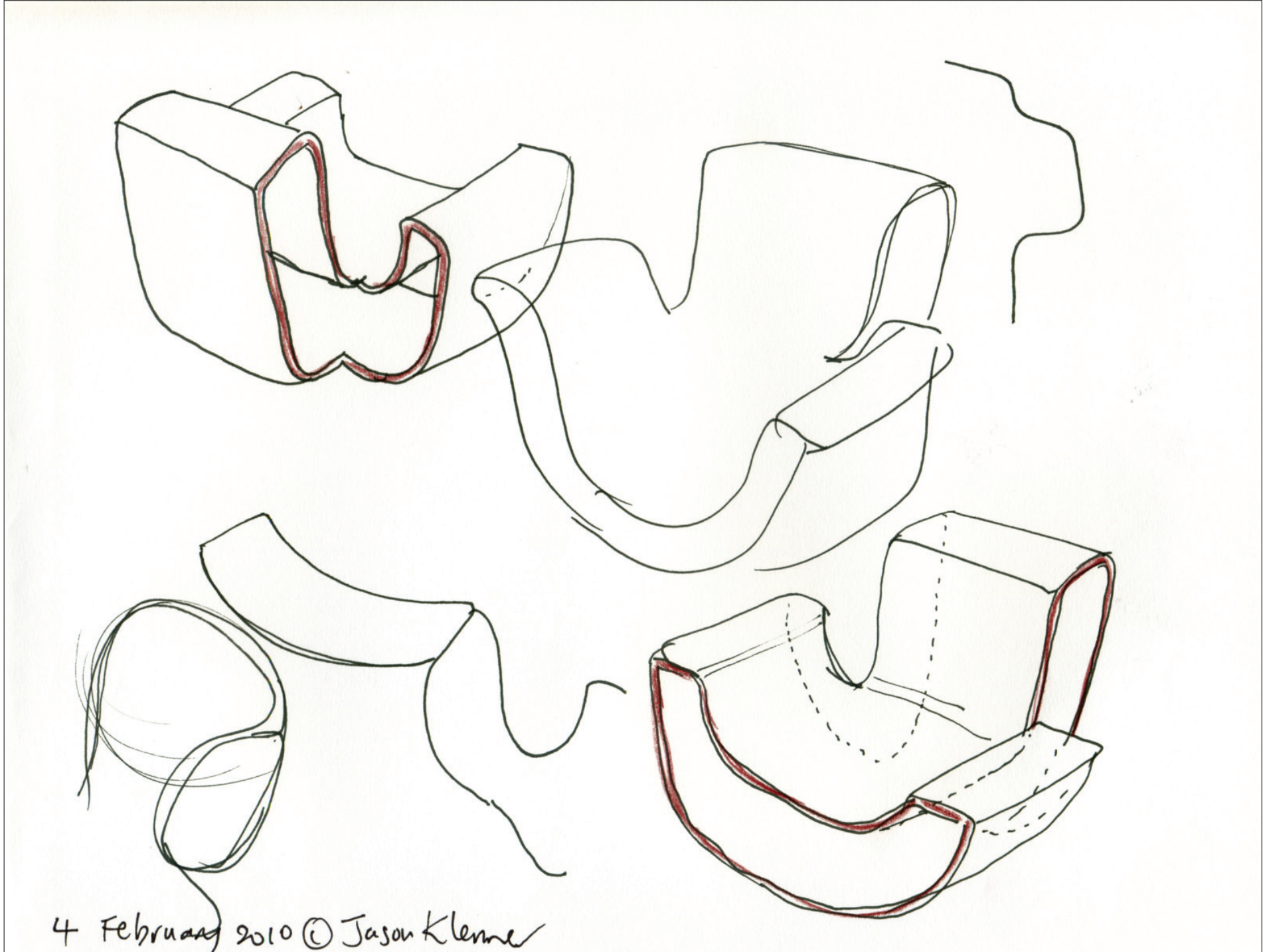

4 Februar 2010 © Jason Klemme

Pg. 2

© Jason Kleener 6 February 2010

Design Art → d moment within product "design."

'Design Now'  
piece by Zaha Hadid.

"A moment between traditional batch production and art!"

Finding my voice as a designer →

generalising, I can be specific about myself

using my view perception about something out of NZ  
that expresses me.

Anecdotal stuff → NZ.

Designer is acting as an artist → reflect their views in a product

© Jason Klenner 6 February 2010

I am acting as a design artist - not a corporate designer.

↳ I have a view perspective of this stuff

---

CREATIVE WORK THEY PRODUCED  
IS WHY PEOPLE CAME TO HIM.

(Newson)

---

Establish my design perspective

---

Alessi → clearly articulate what they are after from design  
↳ transselection process. (art based)

© Jason Klenner 6 February 2017

Companies → I really like where they  
are coming from

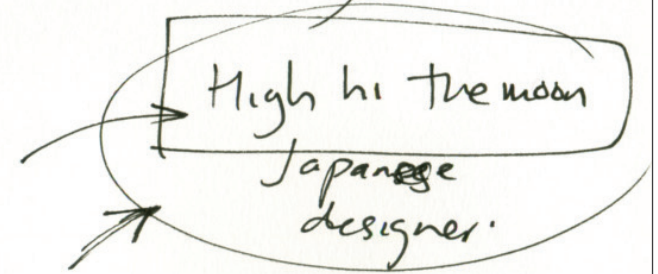

Are there other opportunities apart from  
chairs. →

Fullscale  
→

exploring design ideas → This is what  
it is about

spheres → new dynamic

body support  
↳ erotic

bean bag → classic example

moving  
Spheres →

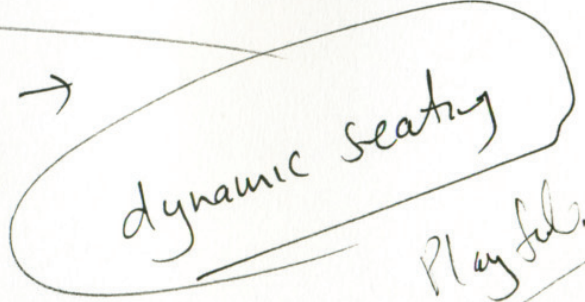

Playful.

Verner →  
Colombo. →

Droog Mecromy Chair.

mat of carbon. → → cold to sit.

Worth pursuing → ~~to~~ pages. → think of  
guys like.

Super ellipse  
table

↓  
when you analyse it  
as a designer you can't  
take anything away

Roots  
as a designer

add to  
this beauty  
↓ supported

## Summary of Discussion with Tony + Mark on 8 Feb 2010

1. Check out the book, Design Art - A movement within product design (this is a movement between traditional batch production and art)
2. Generally, I need to make the theory match the object - it needs to be more personal, I can be specific and talk about myself and it is about finding my voice as a designer.
3. Theory needs to be modified to say 'my perception' about New Zealand rather than reflect the New Zealand aesthetic.
4. Think like I am a designer acting as an artist and I reflect my views into a product or designers like Newson act like artists and they reflect their views into products they design.
5. This is a shift change where I am working as a design-artist, not a corporate designer, where I reflect my perspective onto the product.  
This is a personal perspective in comparison with a result of extensive ~~user~~ design process. (like IDEO + Continuum would perform) i.e. Design by Justification.
6. Check out what each Italian manufacturer is after and target the brand that matches your style.
7. Newson, Starck, etc. These guys are all about the creative work that they produce → that is why people commission them.
8. Also check out Alessi. They have clear documentation about what their selection criteria is all about.

9. Look/explore to see if there are other opportunities apart from chairs
10. The study is all about - exploring design ideas.
11. Tony described my work as playful.
12. Look at dynamic seating further, for example Verner Panton and Joe Colombo did this in the past. They were experimental.
13. Start to work in a full size scale → Truly experiment
14. Imagine things like, the spheres could move up and down as a sculpture until you approached the chair, then it went into a seating position.
15. Spheres was described as interesting.
  - dynamic was liked
  - too static currently
  - investigate more of an associated experience
16. Sheet/mesh was described a more conventional → investigate more of an associated experience - wobble factor.
  - carbon - warm <sup>to sit on</sup> but still could wobble.
  - Look at Droog Macramey chair
17. Book was liked, ~~this~~ Tony was excited by the sketches - the form does not match the idea. Different cushions could be for pets, unwanted guests, indecisive couples etc.
18. Poetic is difficult to achieve → it is <sup>about</sup> if you analyse the design nothing can be taken away.

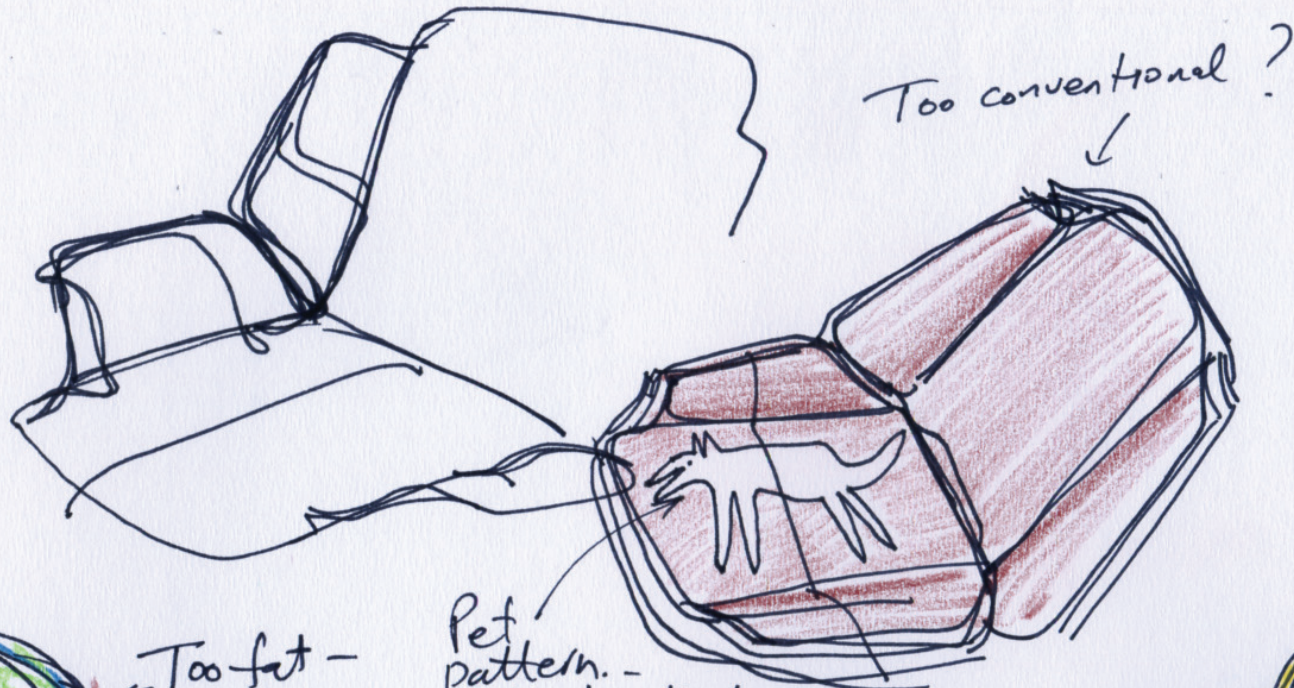

Too conventional?

Tube?

Too fat - proportions

Pet pattern. - indicating that it is the pet's layer. i.e. durable fabric etc

height varies depending on colour pattern choice.

lovely

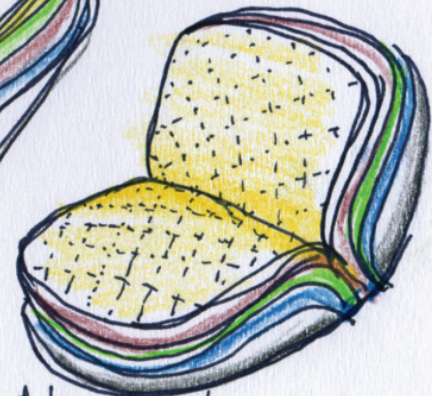
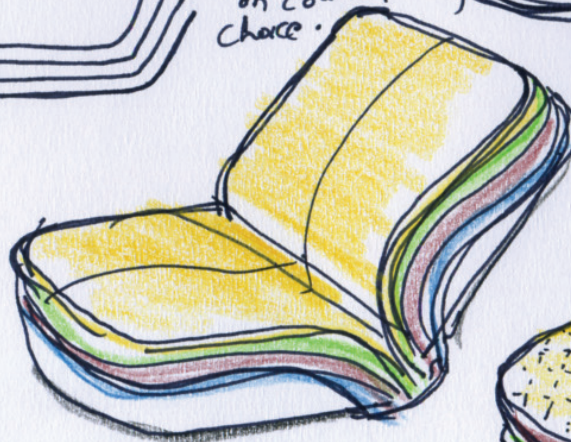
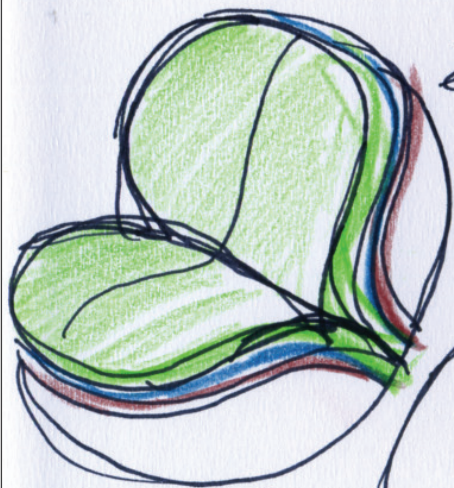

Symmetry. (same component base base)

13 February 2010 © Jason Klemmer

Other items to design:  
other possibilities

- Lighting
- Seating
- Toaster / small appliances.
- Clocks.
- Jewelry

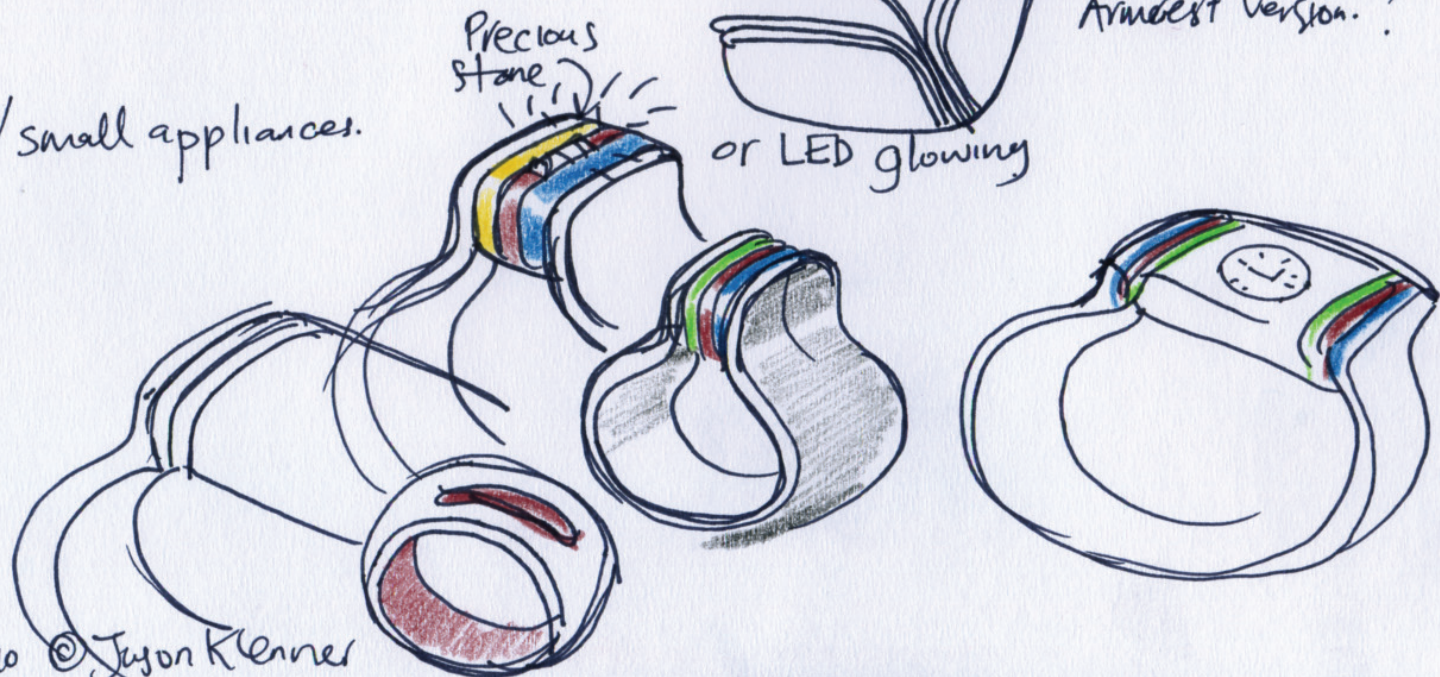
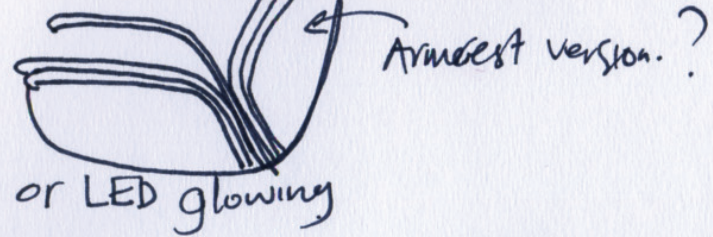
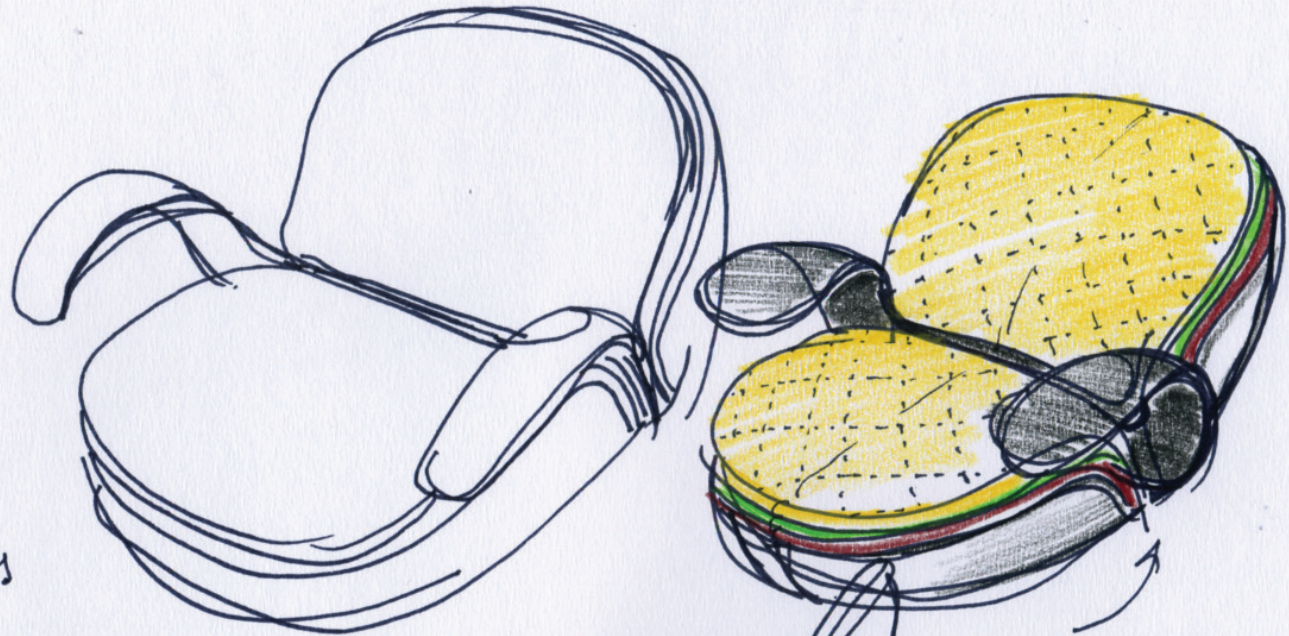

13 February 2010 © Jason Klenner



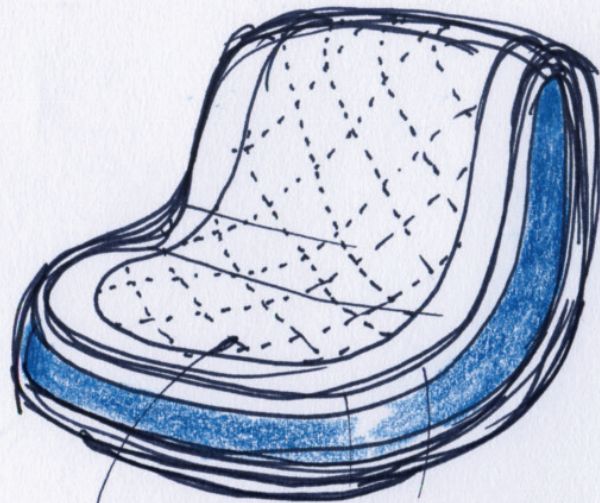

Carpet wrapped around frame.

Large Lounger

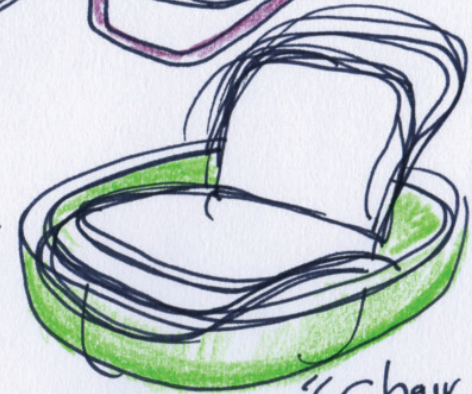
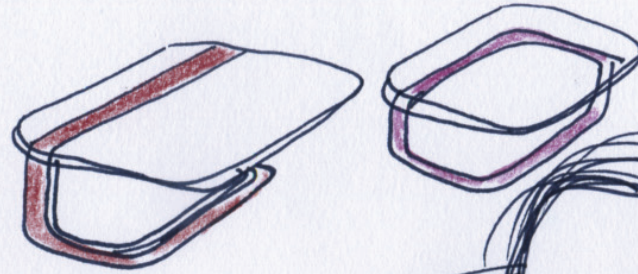

"Chair in a tub"

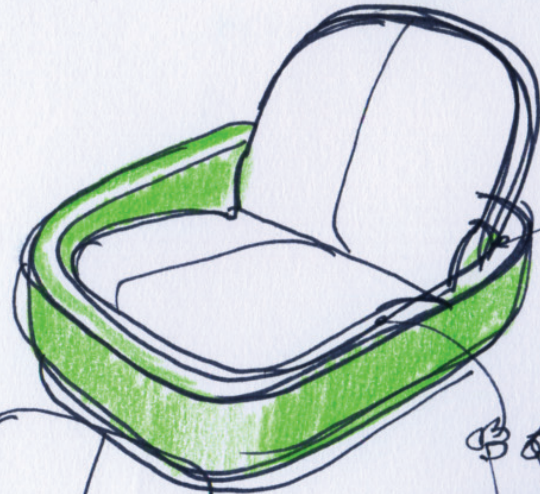

Armrests

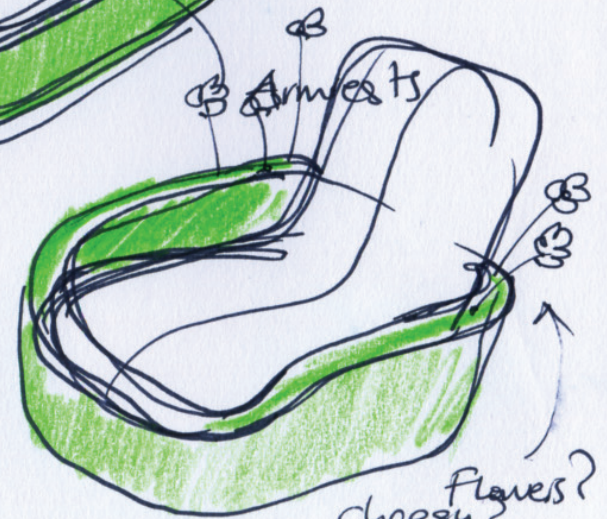
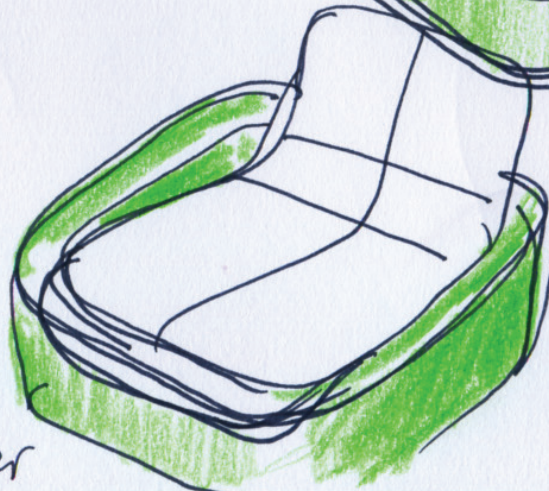
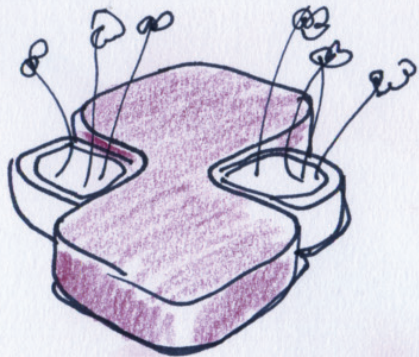

Armrests

Flowers?  
cheesy?

13 February 2010 © Jason Klenner

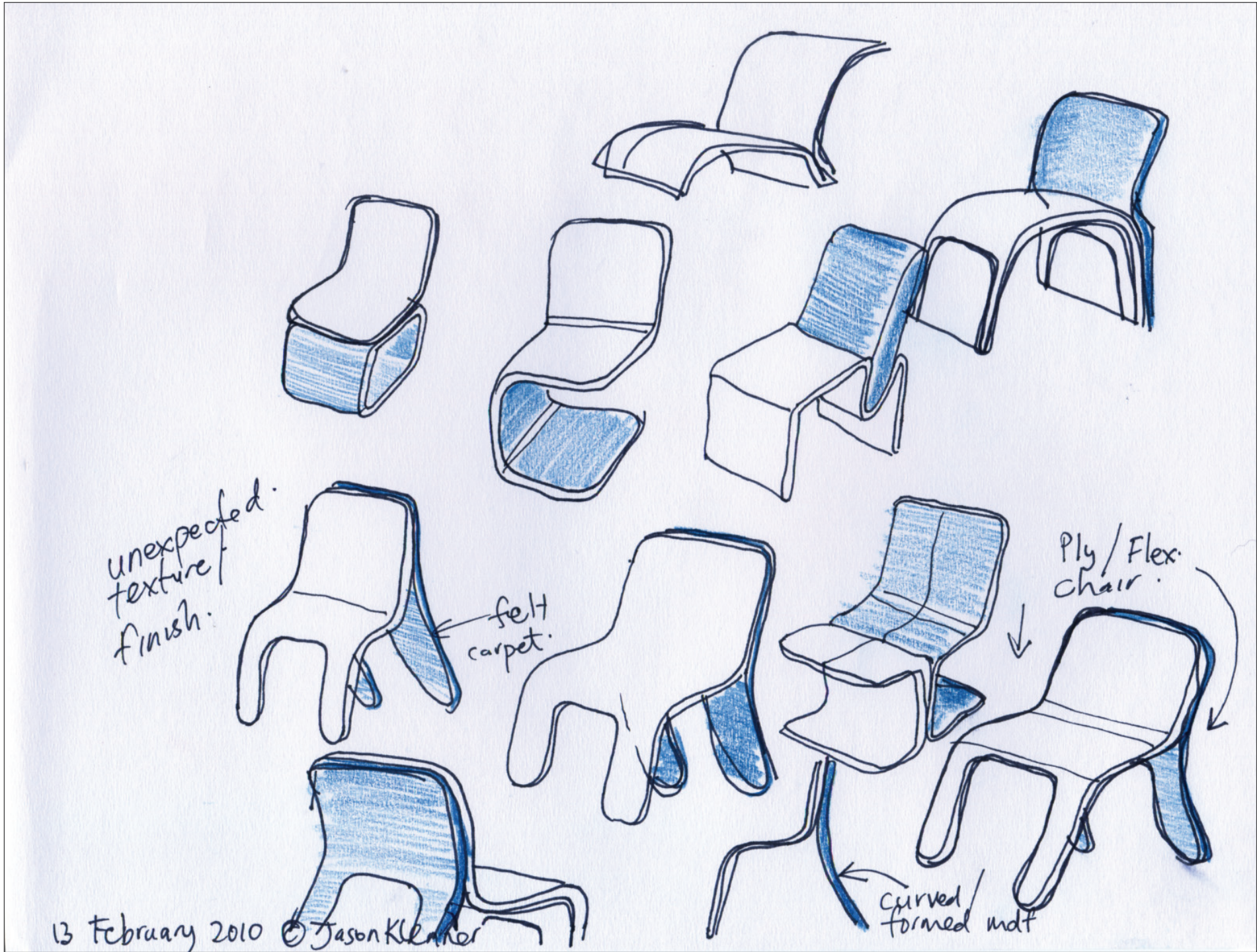

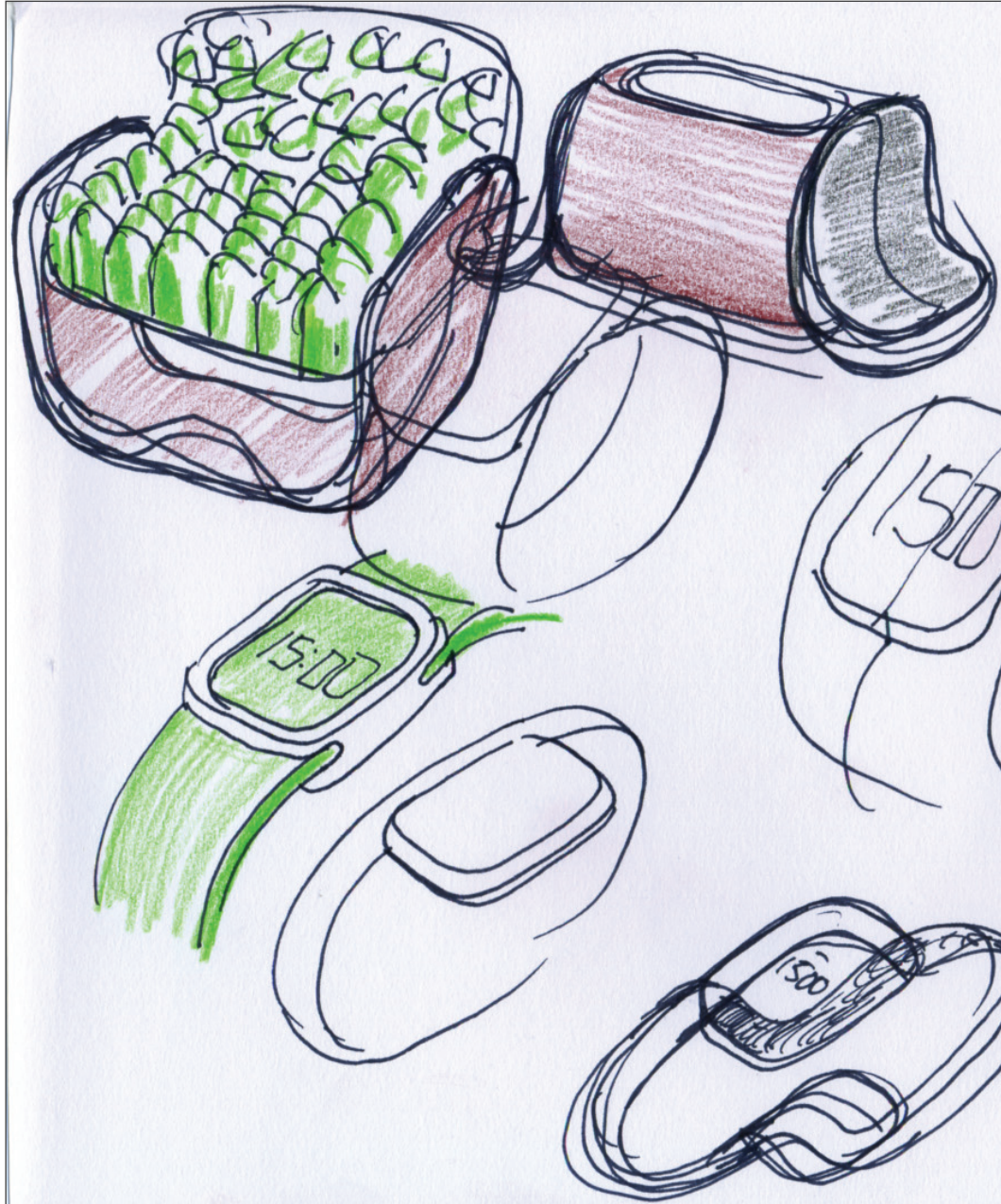

What is my personal position. → light hearted. ?  
Joke.  
Playful. ?

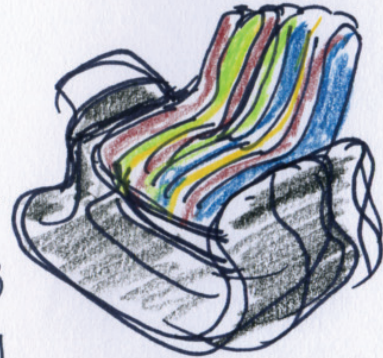
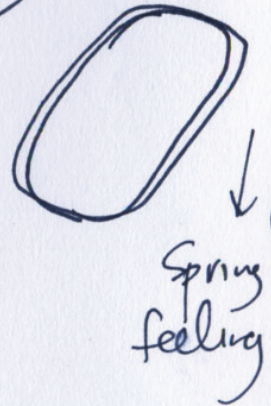

13 February 2010 © Jason Klemer

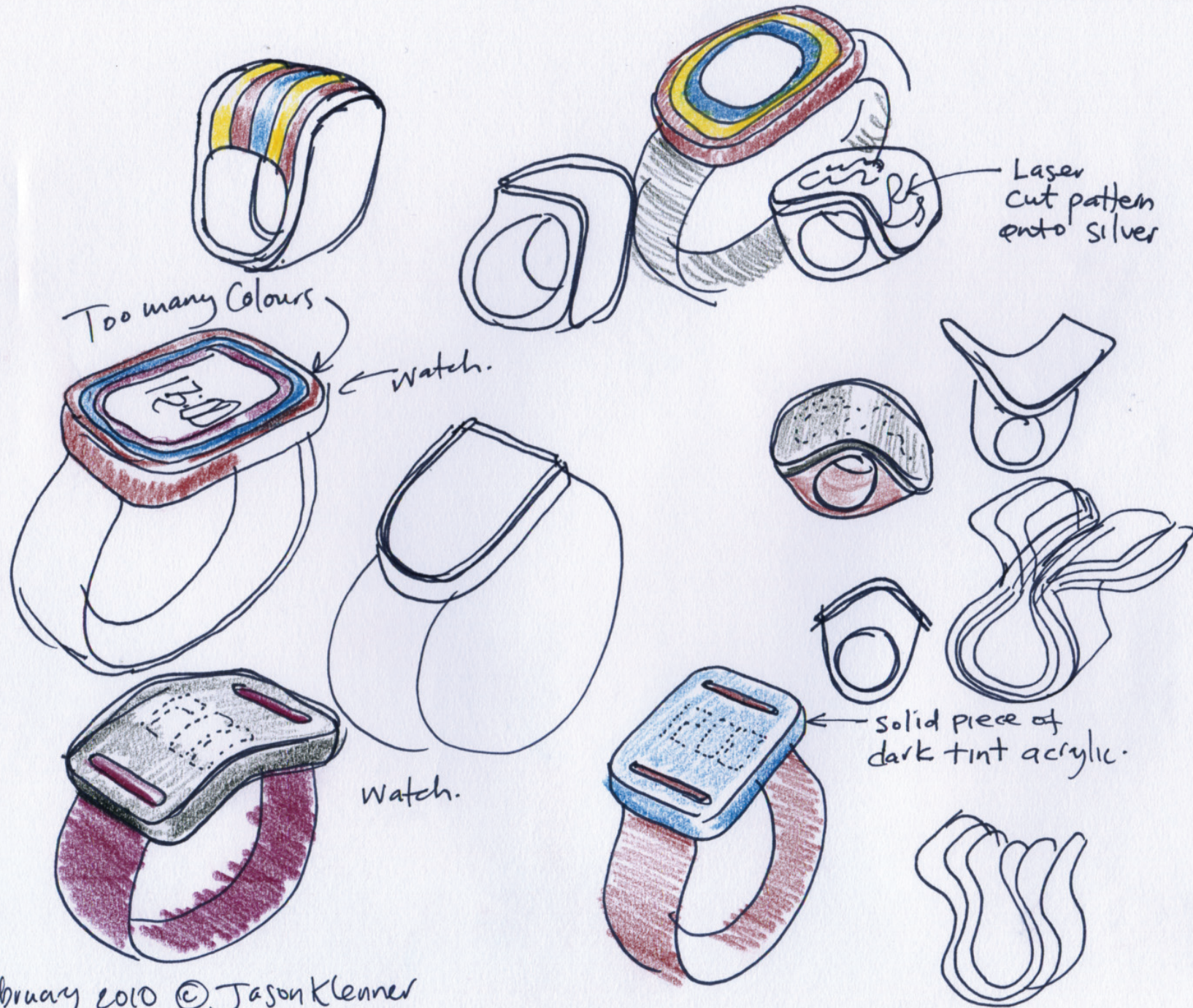

13 February 2010 © Jason Klenner

Summer/  
winter

integrating armrest ↴

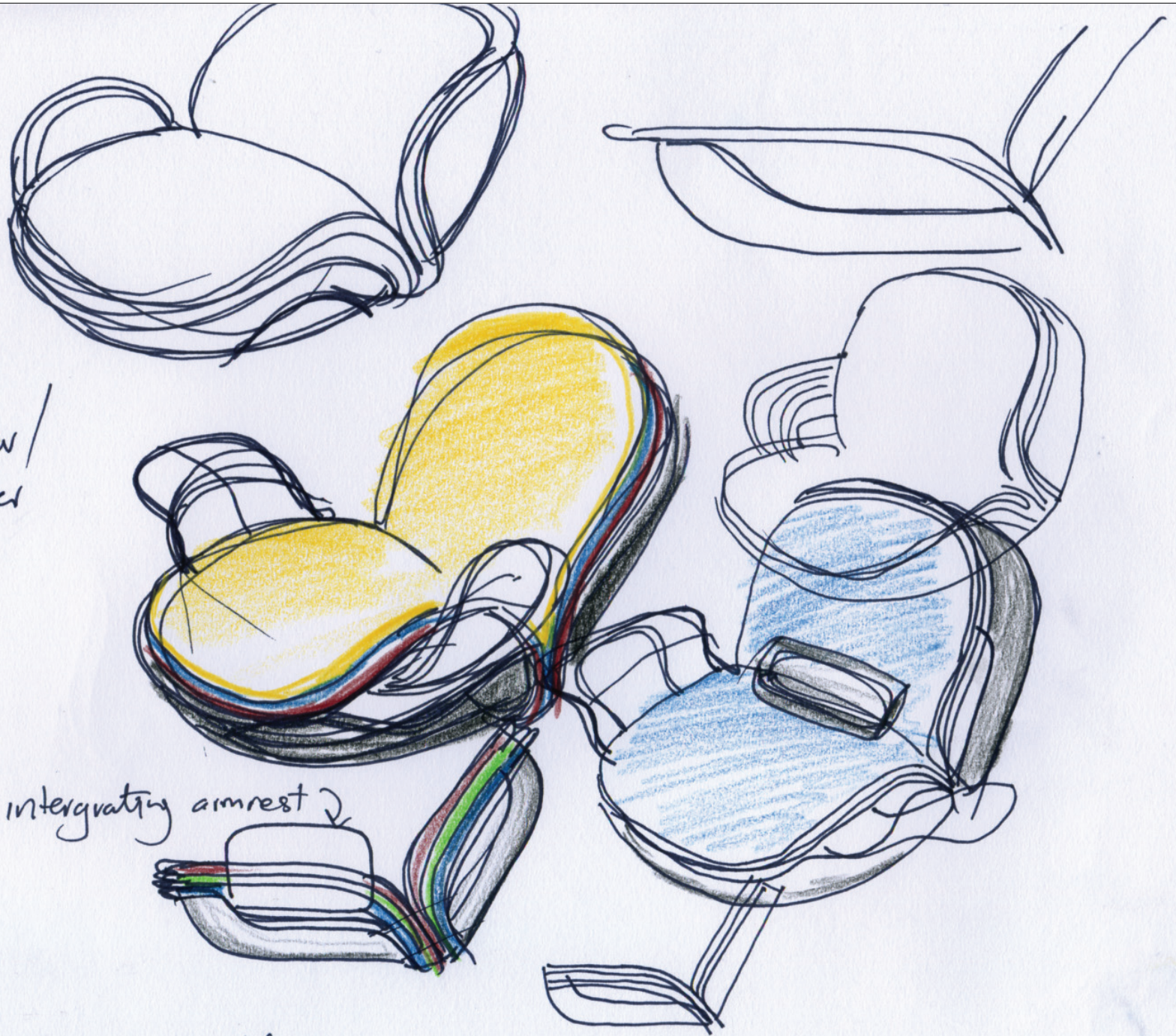

13 February 2010 © Jason Klenner

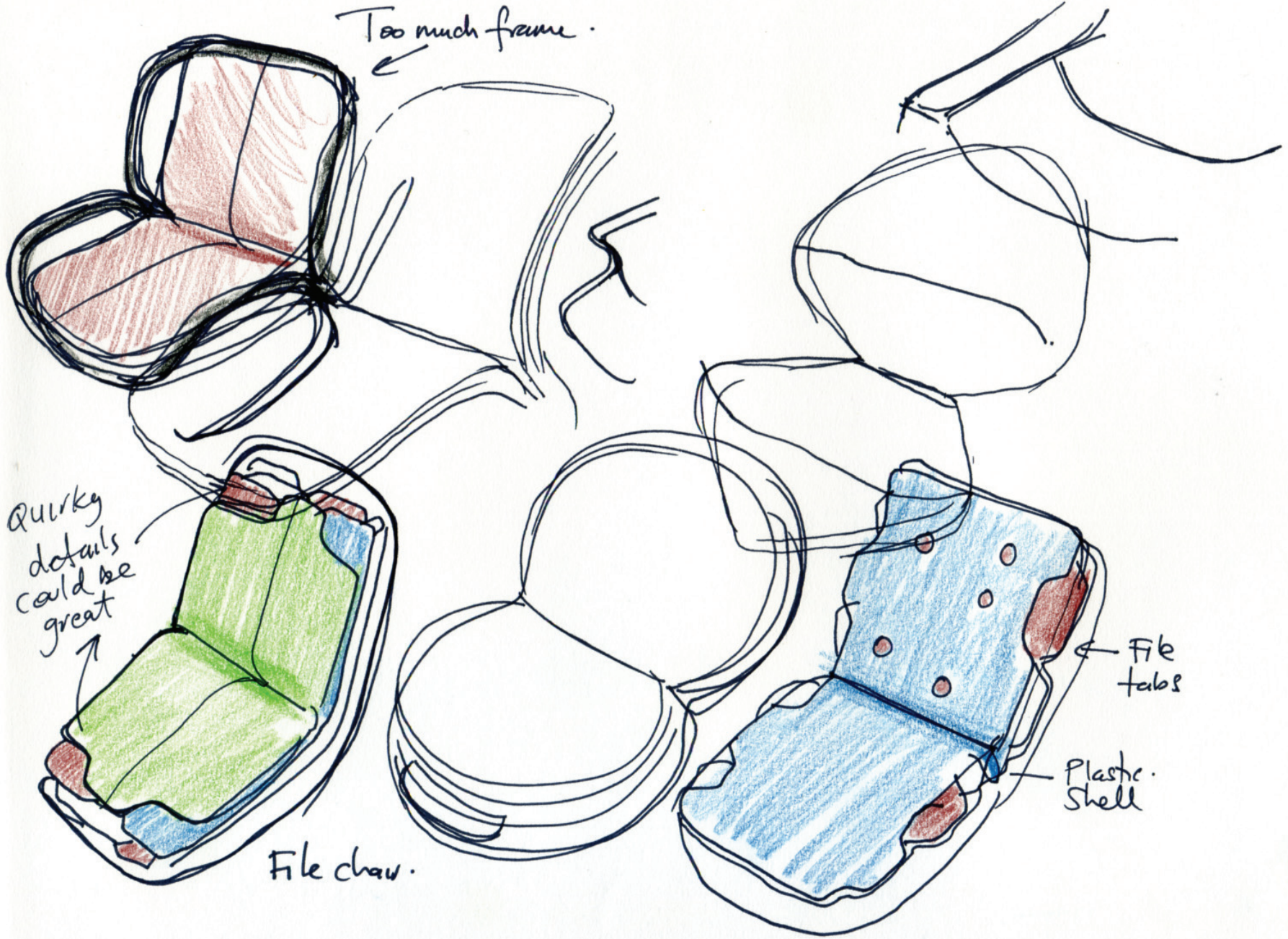

13 February 2010 © Jason Klenner

Armrests

How can this be achieved.

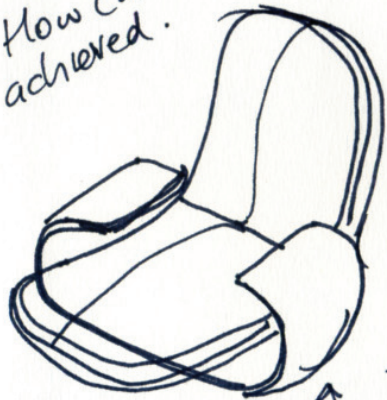

Floating ?

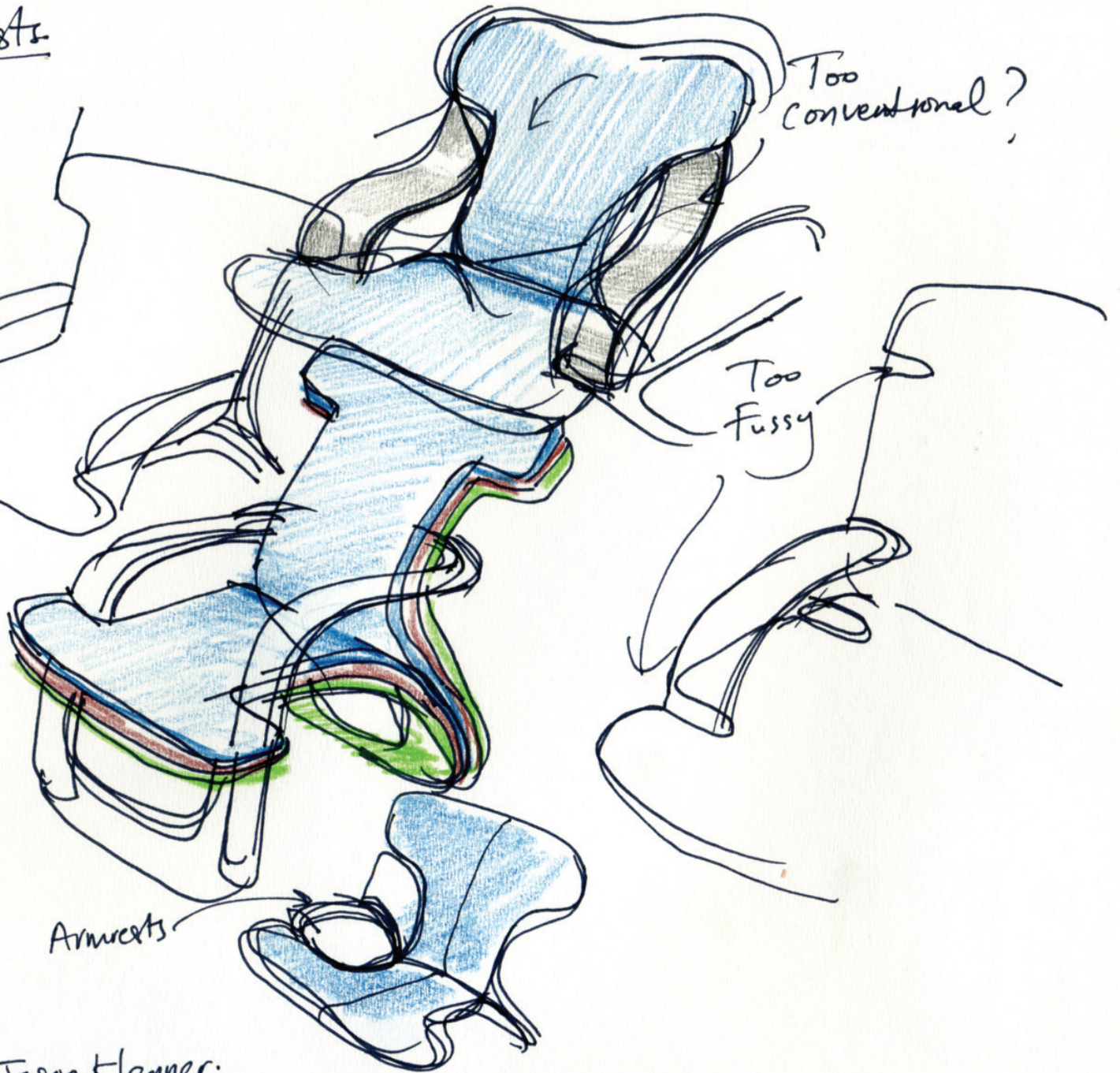

Too conventional?

Too Fussy

Armrests

13 February 2010 © Jason Kleener.



Problem = The bulk of  
The chair is the body  
colour, not the upholstery  
colour.

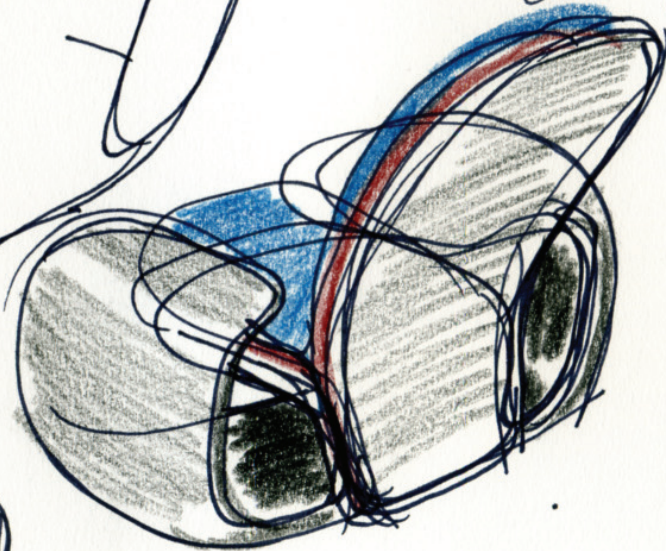
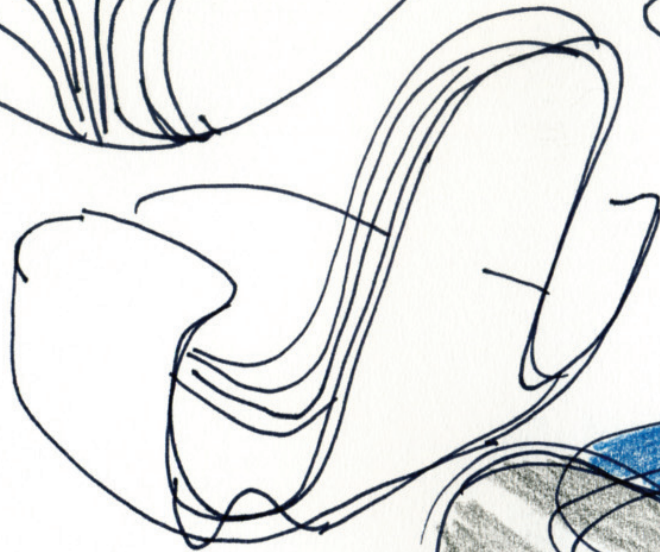

light weight



Carbon  
Sheet  
bent?

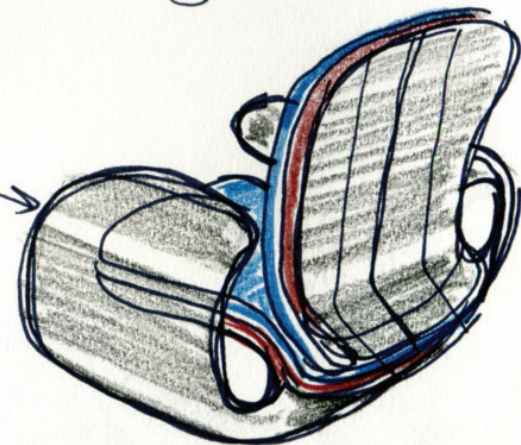

13 February 2010. © Jason Klenner

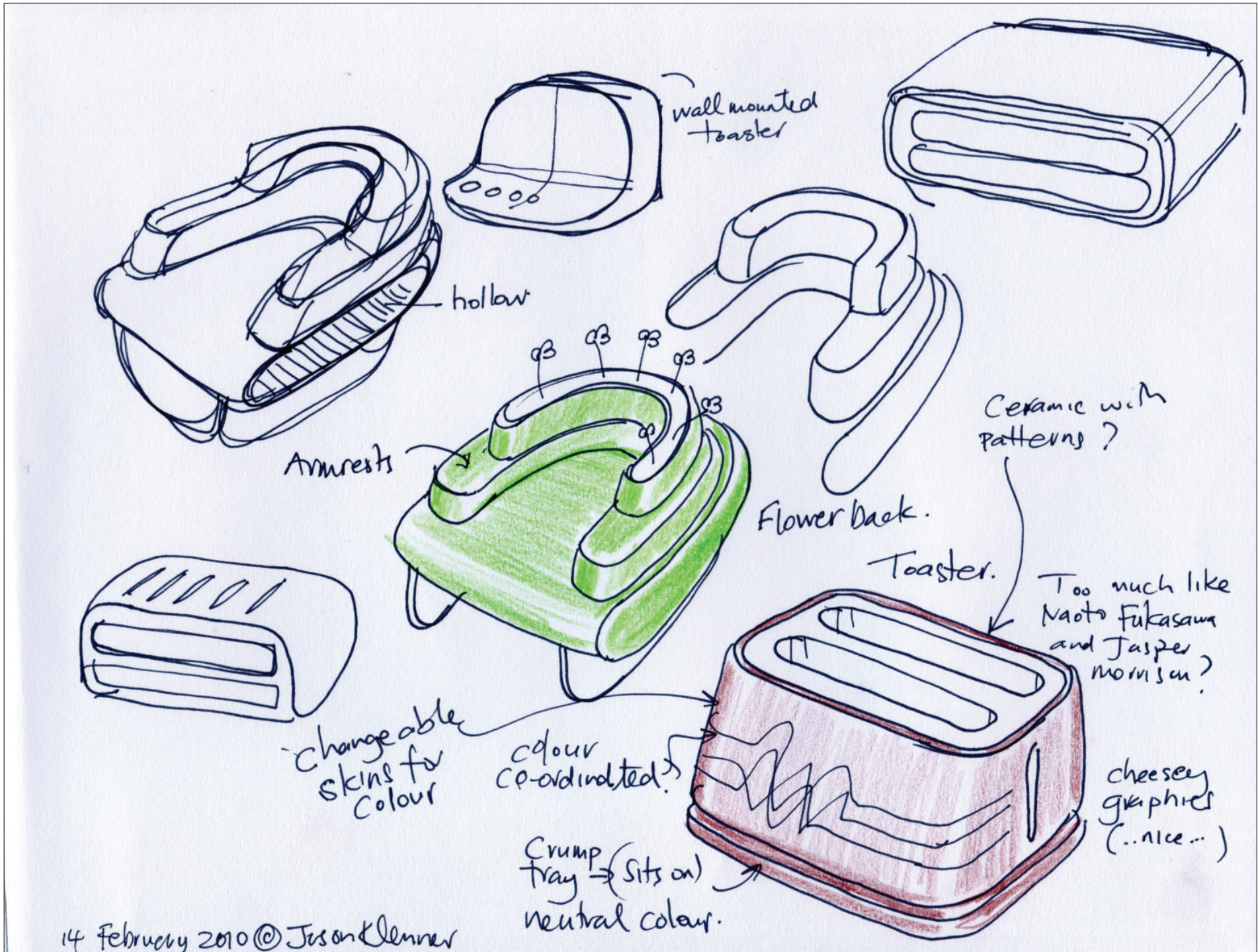

14 February 2010 © Jason & Jenner

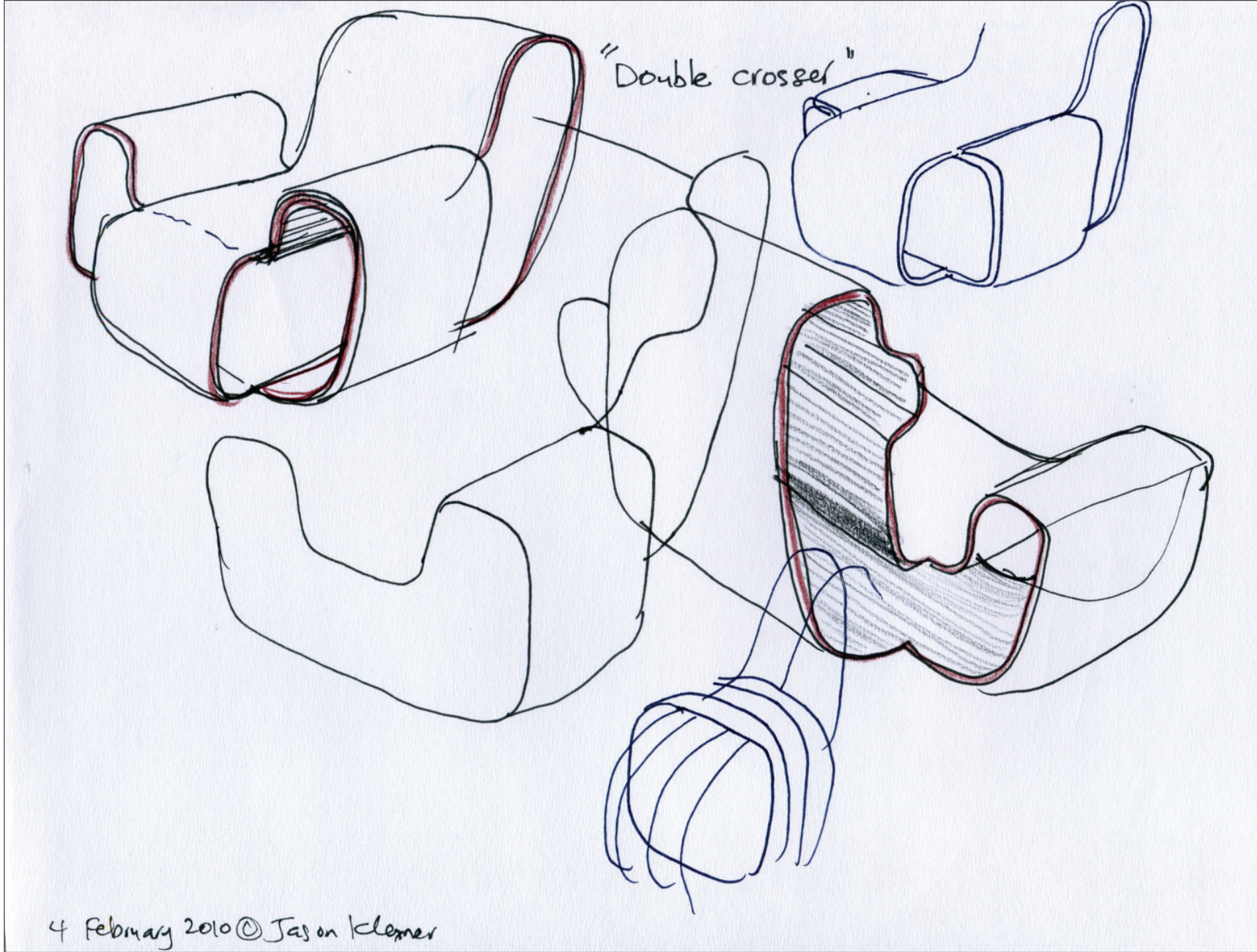

"Double crossover"

4 February 2010 © Jason Klemmer

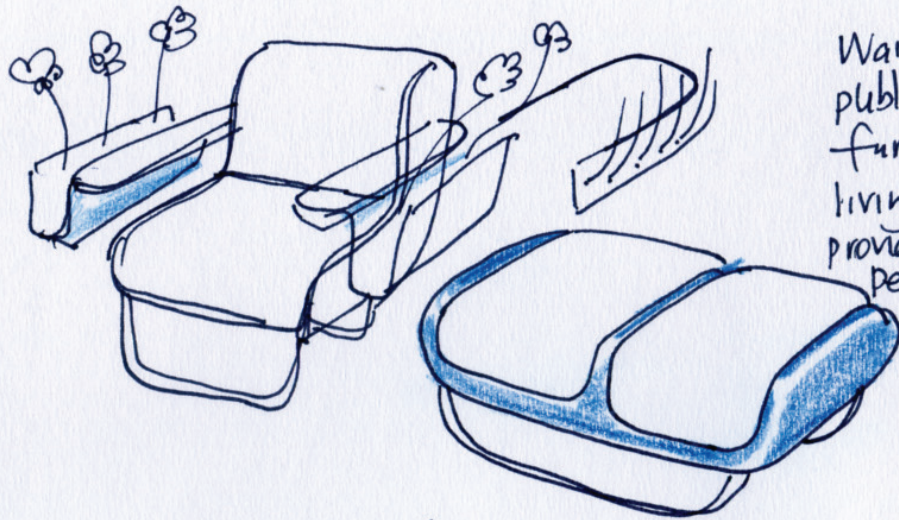

Waiting room/  
public space  
furniture.  
living plants  
provides  
personal  
space.  
(illusion)

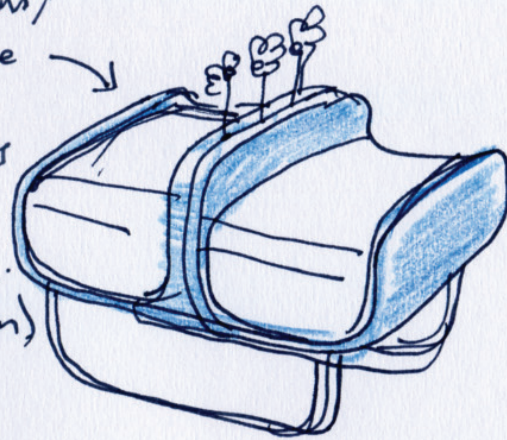

What possible themes/statements could  
be used for this object:

- Day on the beach.
- Dynamic/moving seating
- Multi-positional seating.
- shade for outdoor furniture
- lovers seat
- incorporates plants
- Dressable.
- lightweight chair
- Jewelry
- Spice rack

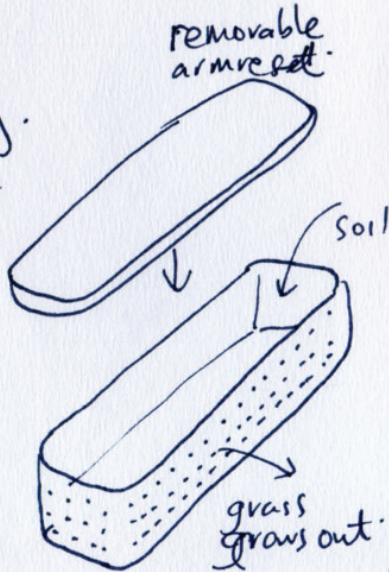

- Possible products
- Furniture
  - outdoor furniture
  - Picnic furniture
  - kiwi bbq
  - low tech household products

outdoors indoors  
indoors outdoors

- radio
- clock
- kettle
- lamp
- telephone.

add an emotional  
and desirable form.  
apply the lessons  
learned from furniture  
industry



14 February 2010 © Justin Klenner

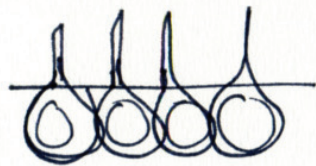

Book storage

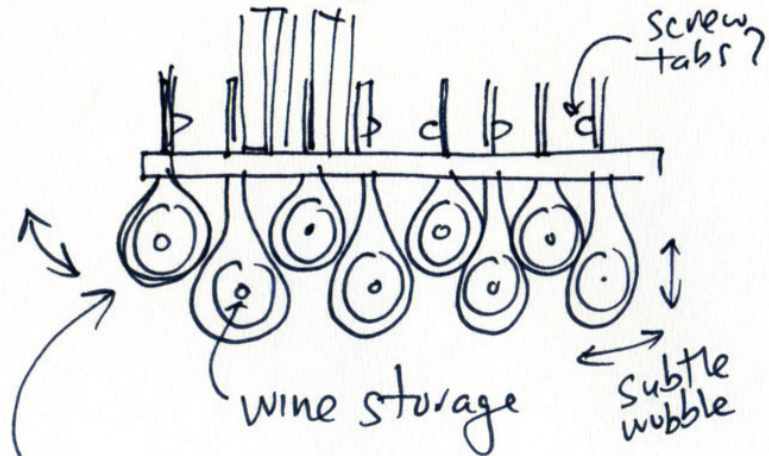

Floating feeling  
Suspended.

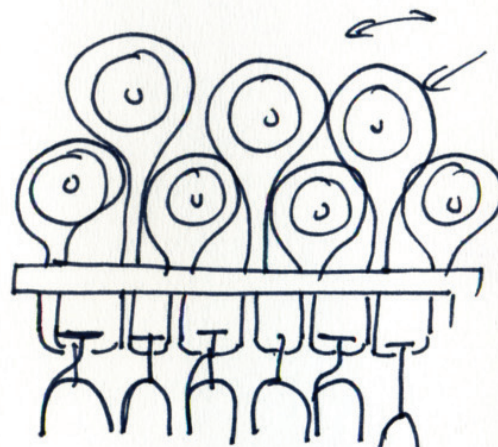

Note: Too heavy for wall?

14. February 2010. © Jason Klenner

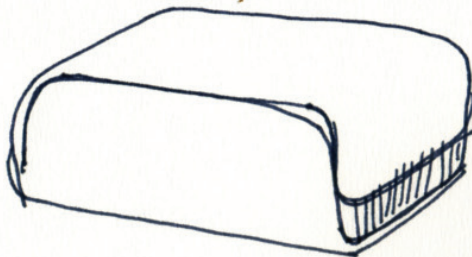

OLD School  
STYLING:

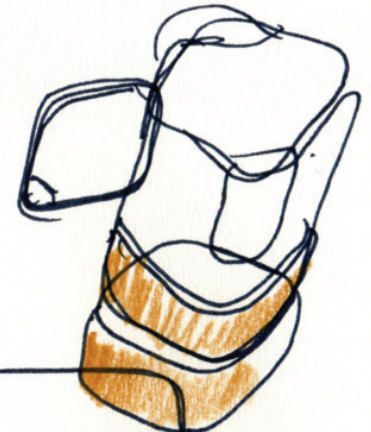

Bread Metaphor?

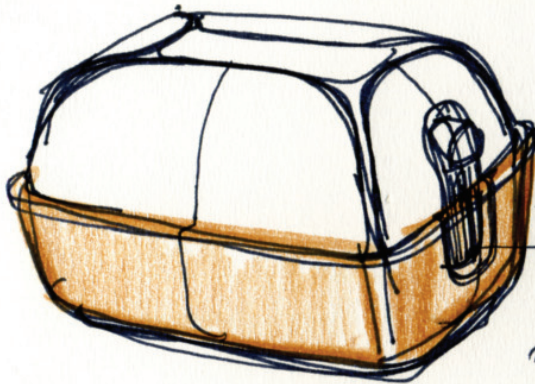

Toaster.

earthy  
terracotta  
base.

"Solid feel"



metal.

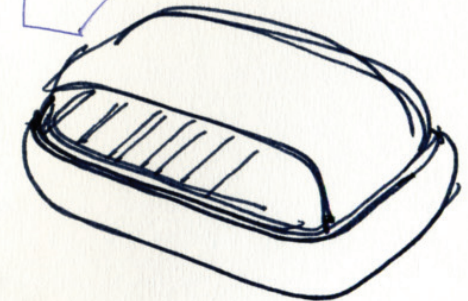
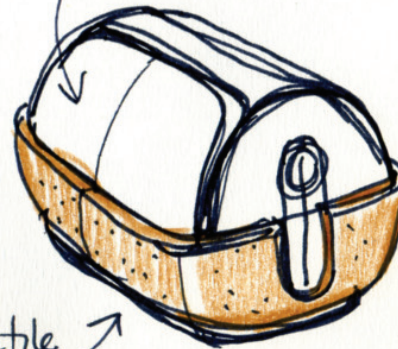

Provides a tactile  
zone



Electric kettle.

terracotta.

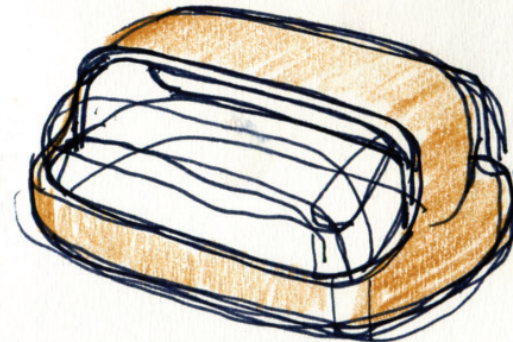

14 February 2010 © Jason Klennor

# Kitchen products -

- Compact
- Stackable/system for storage/rational outline
- Colour.
- New proportions

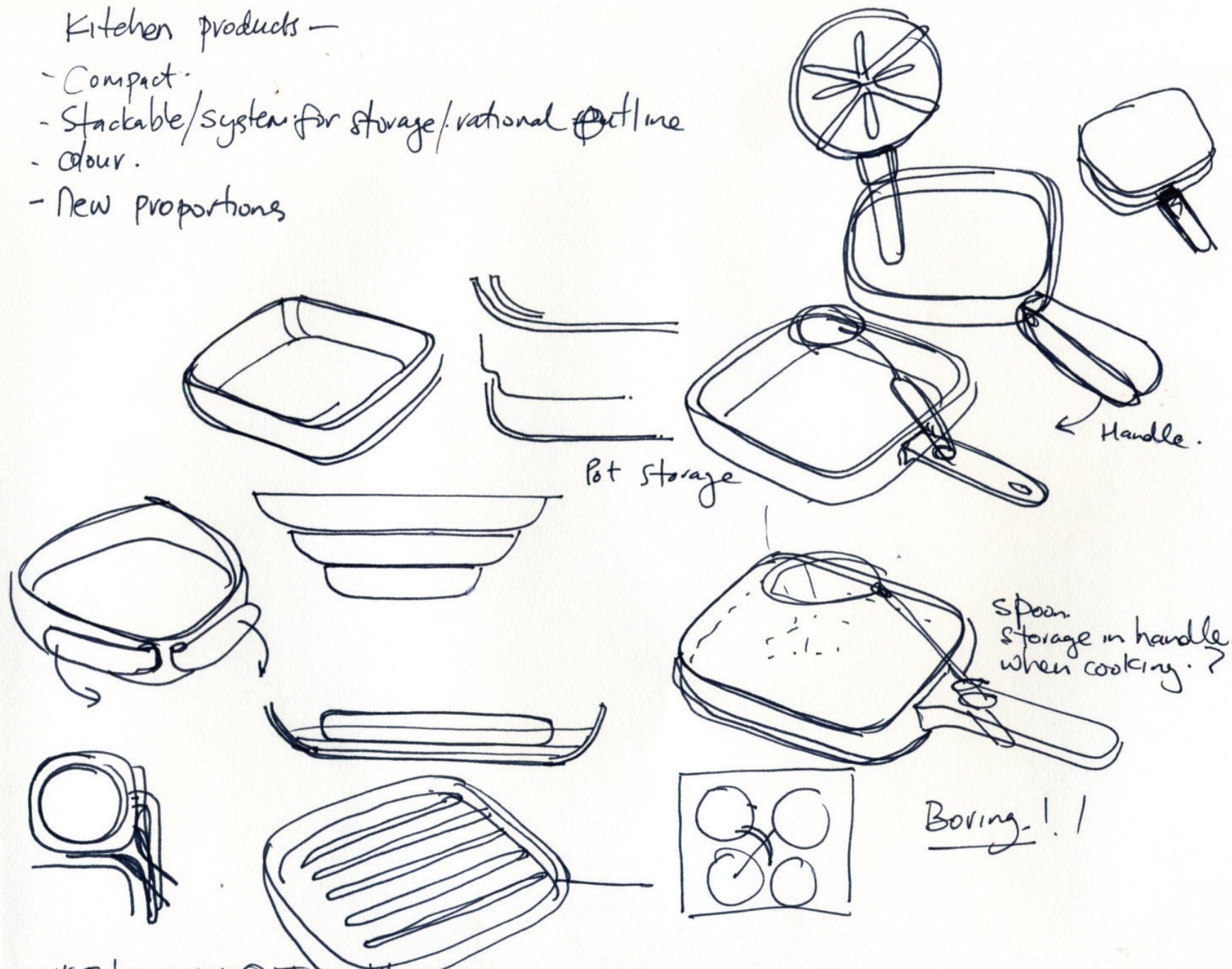

14 February 2010 @ Jason Klenner

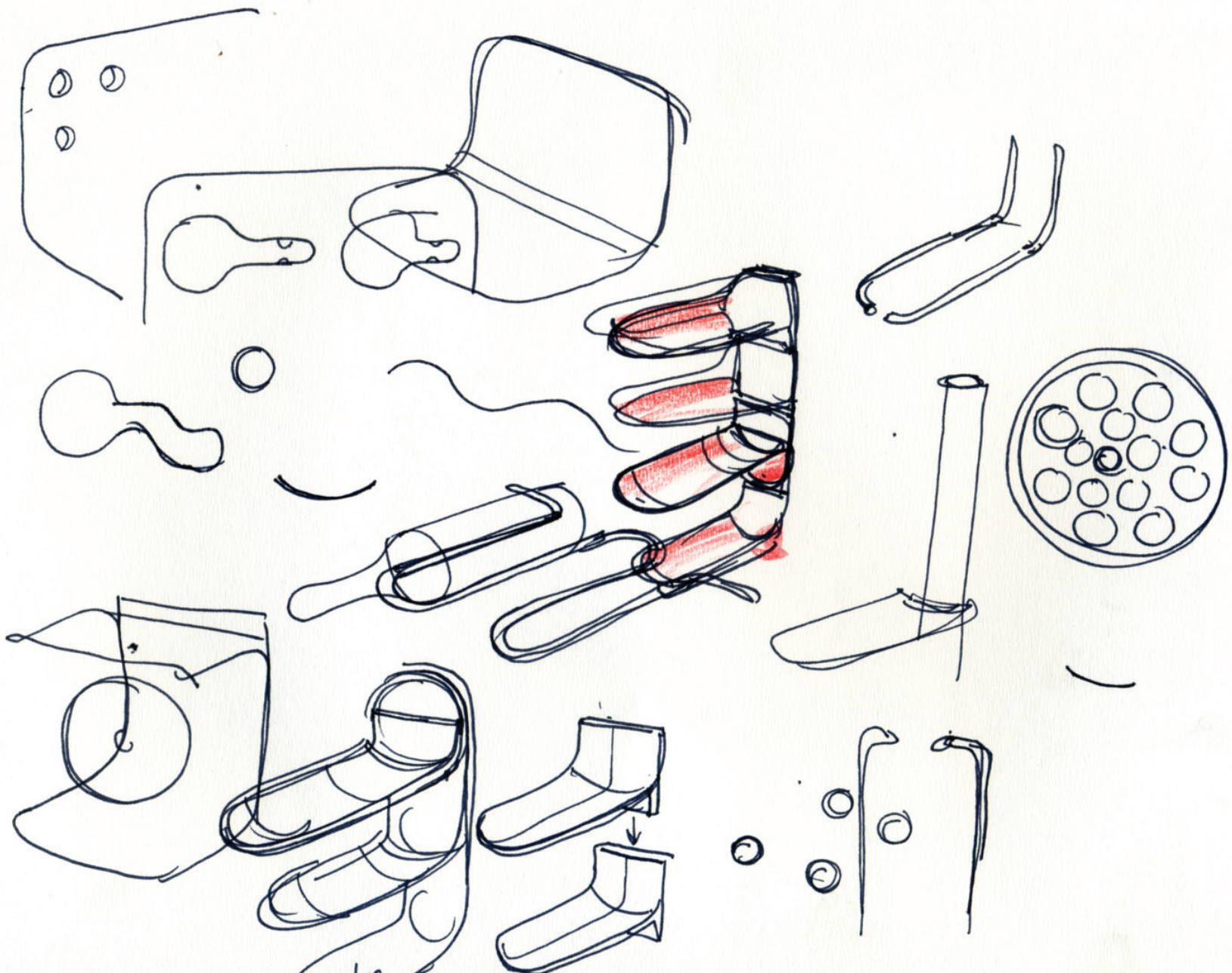

14. February 2010 © Jason Clanner

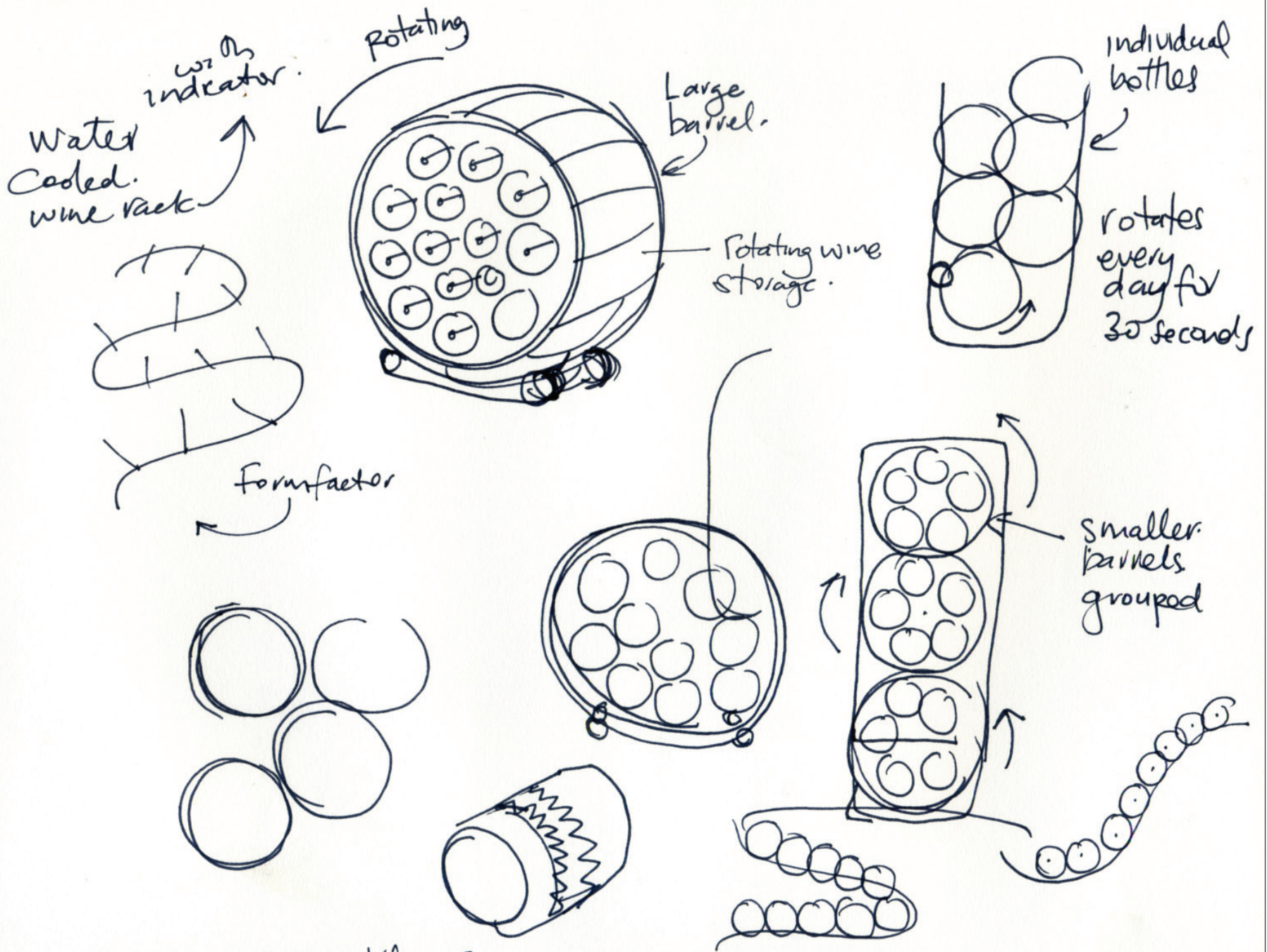

14. February 2010 © Jason Klenner

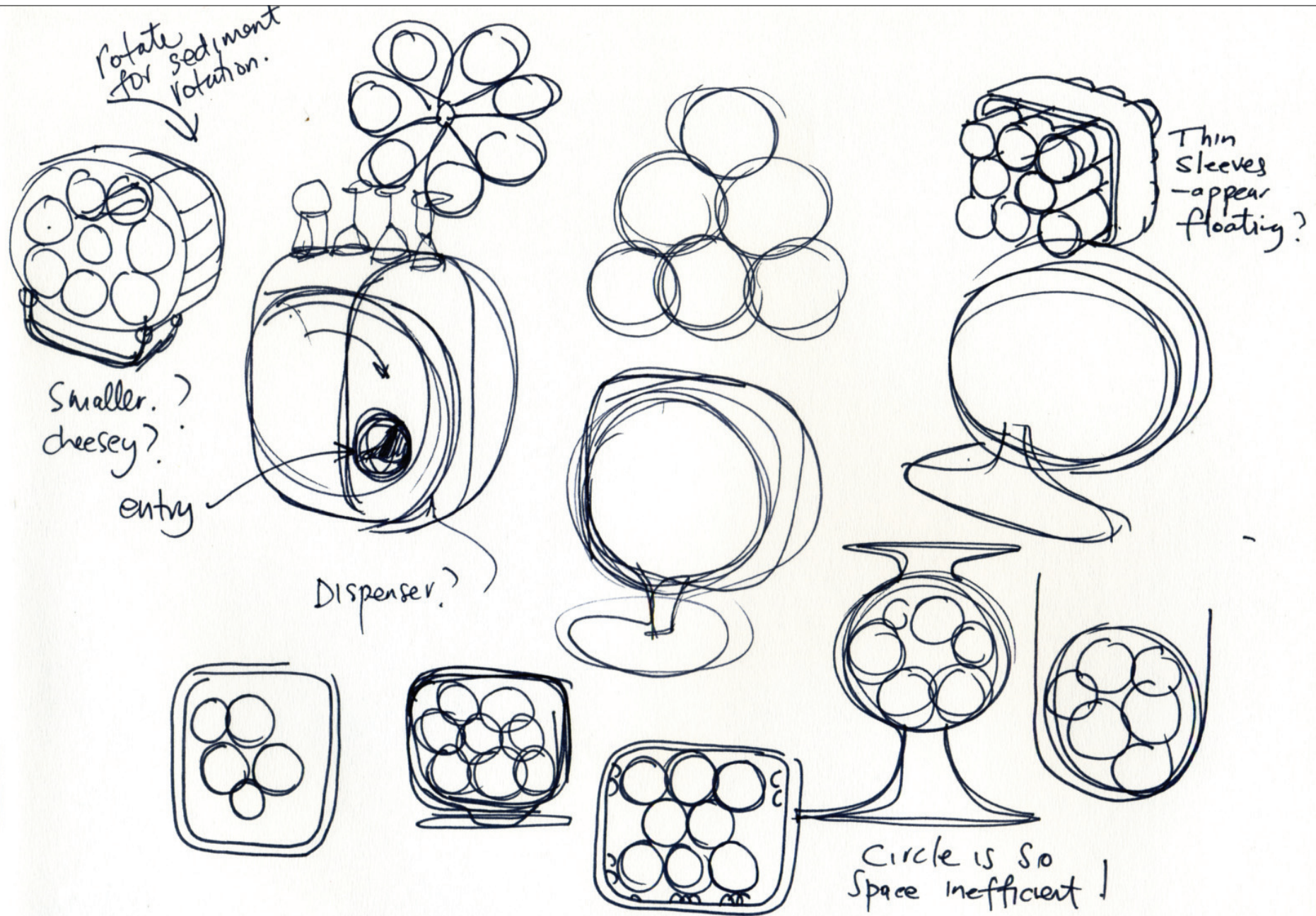

14 February 2010 © Jason Klemmer

Semi formed profiles  
of PP or spring steel.

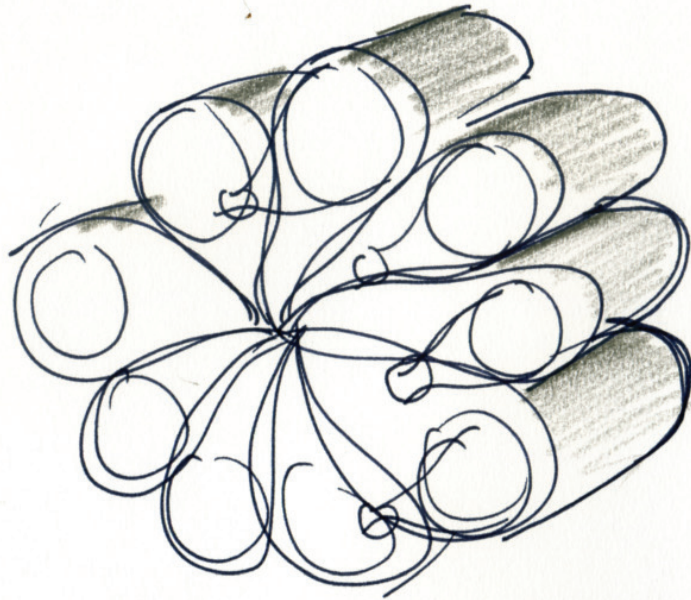

More Sculptural  
wine bottle storage.

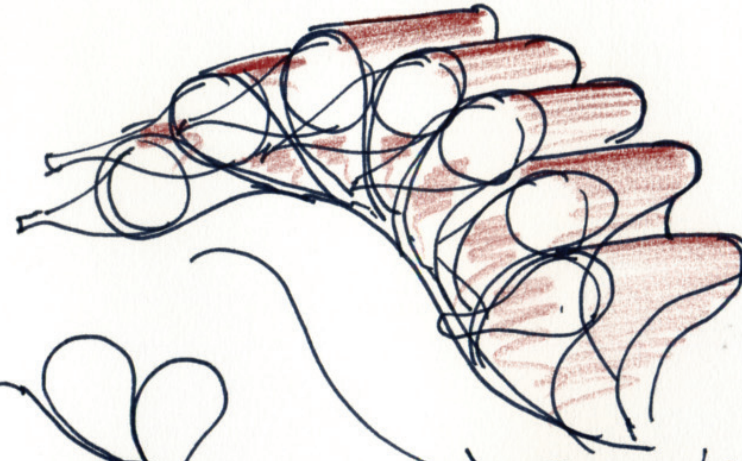

Flowing form

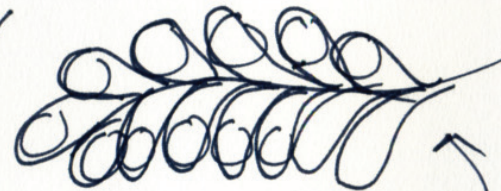

Wall hanging

Books too!

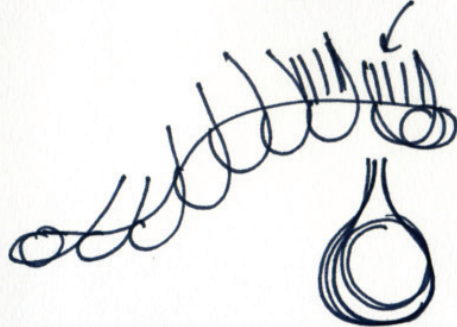

Freestanding



14 February 2010. © Jason Kenner

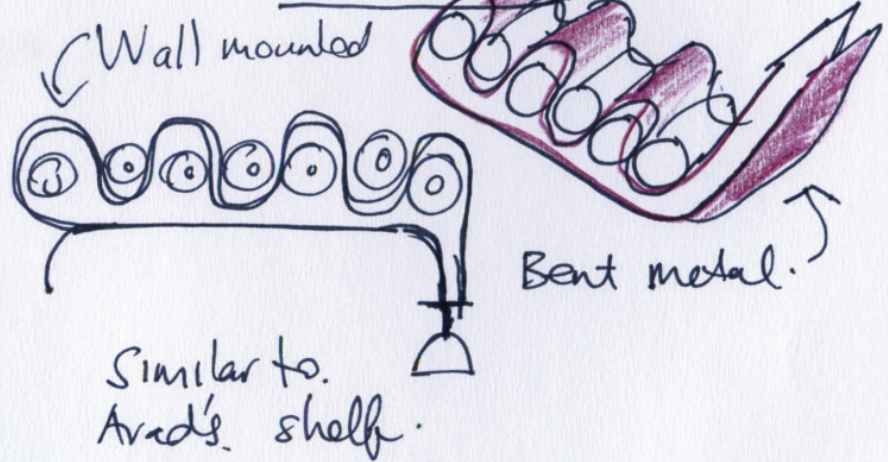
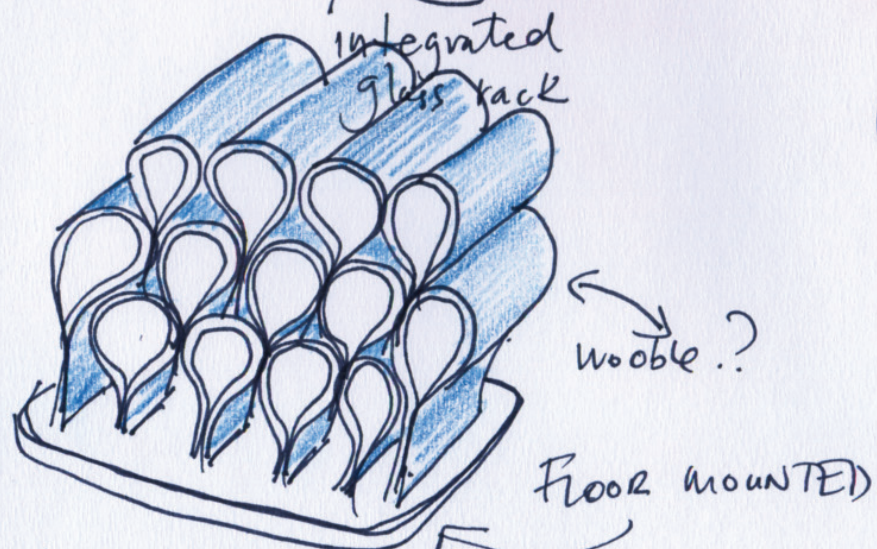
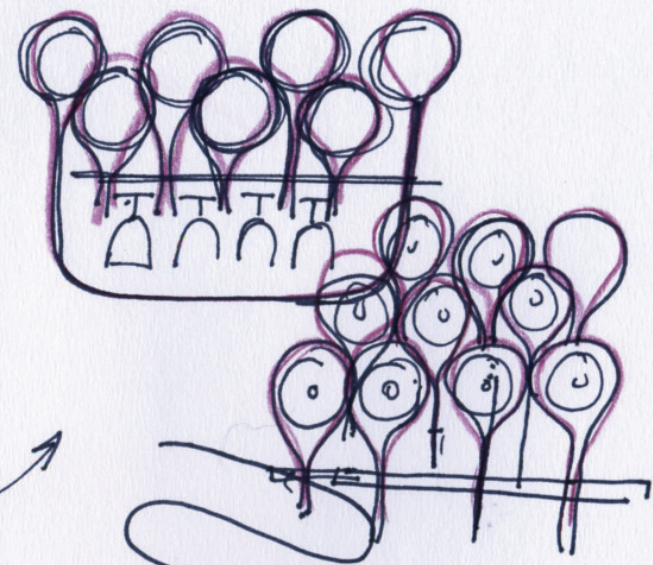
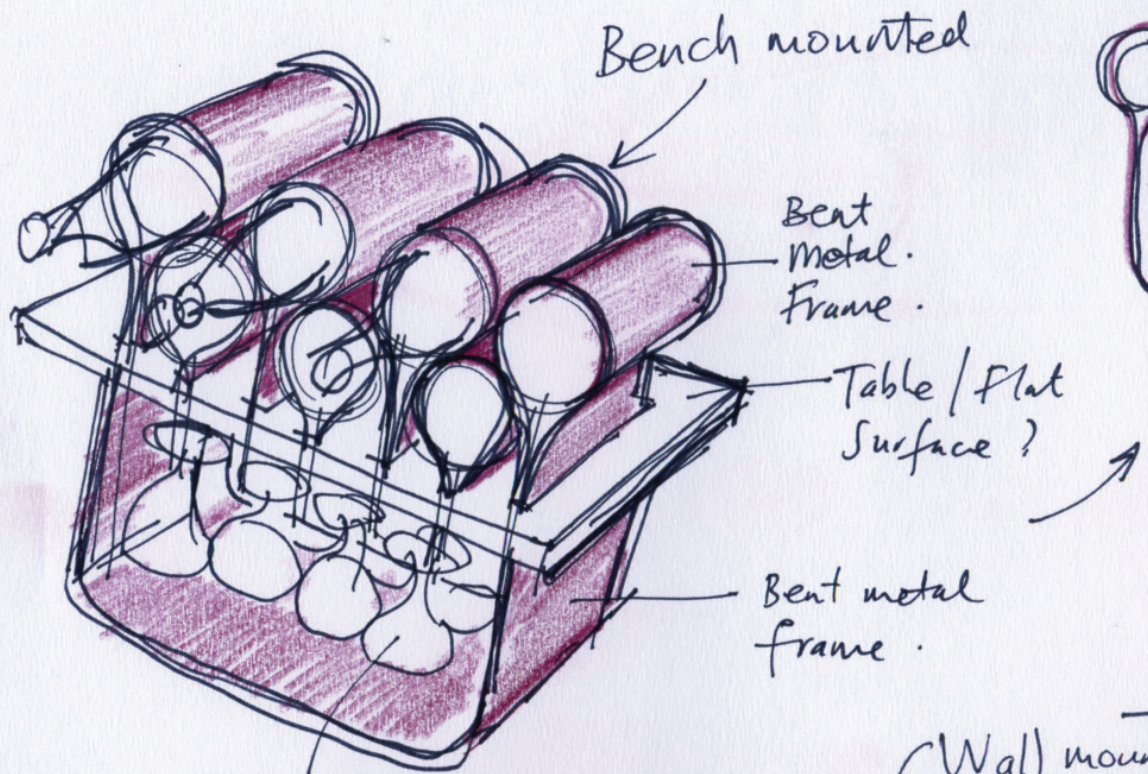

15 February 2010 - © Jason Klenne

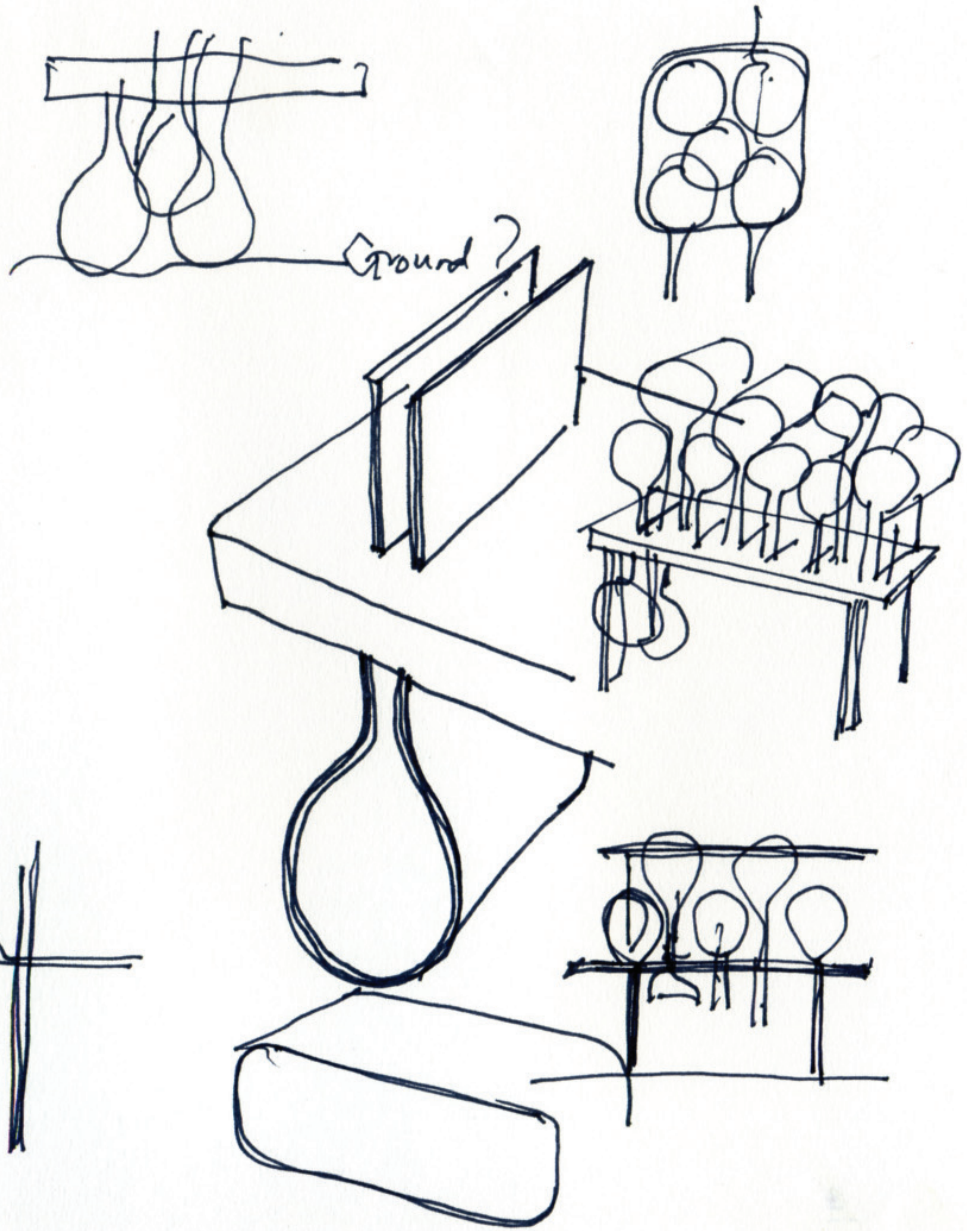
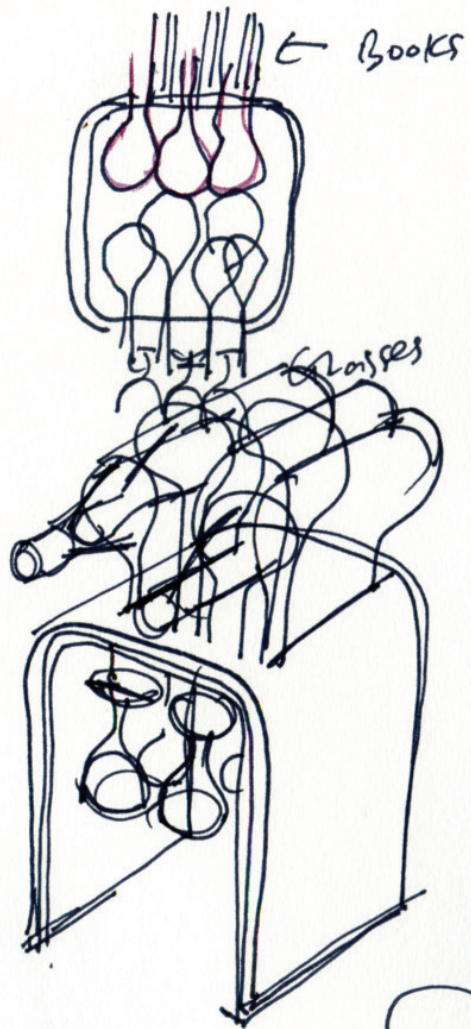

15 February 2010 © Jason Klenner

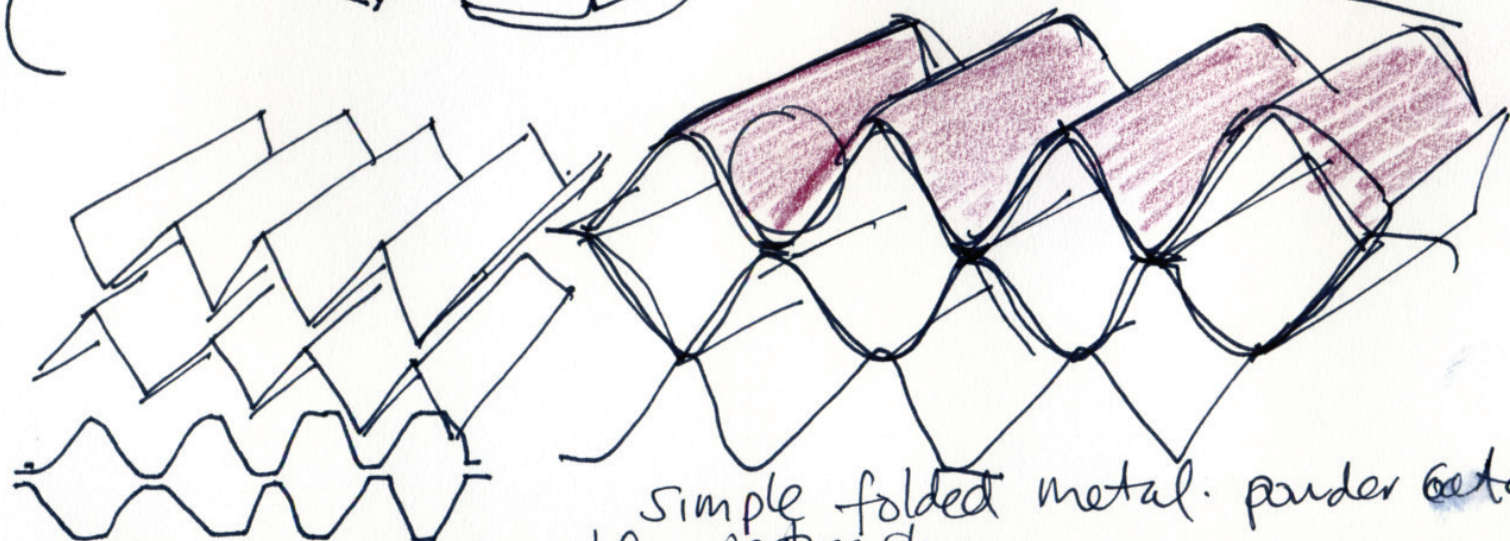
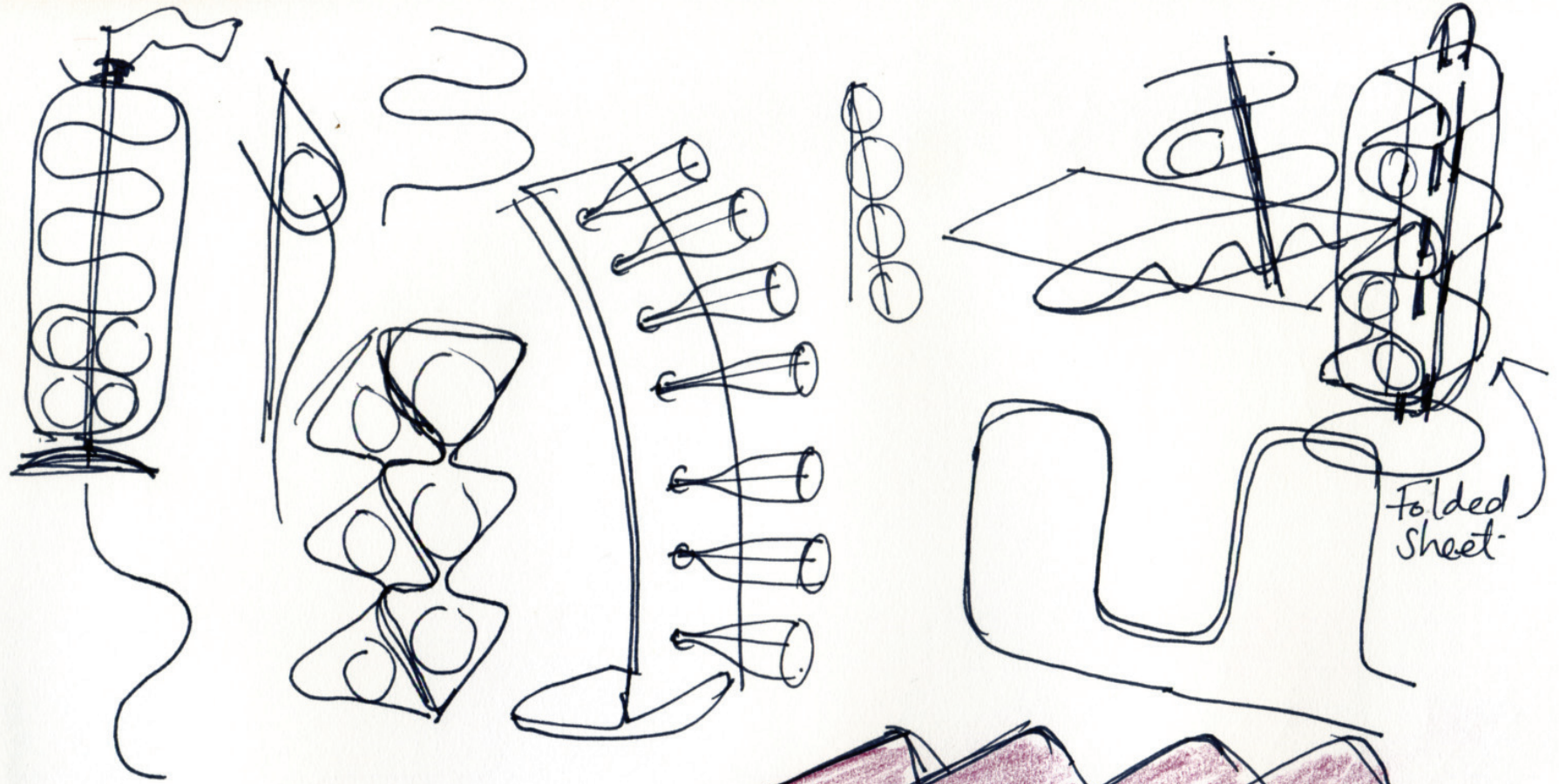

15. February 2010 © Jason Kerner *Nesting Shapes*

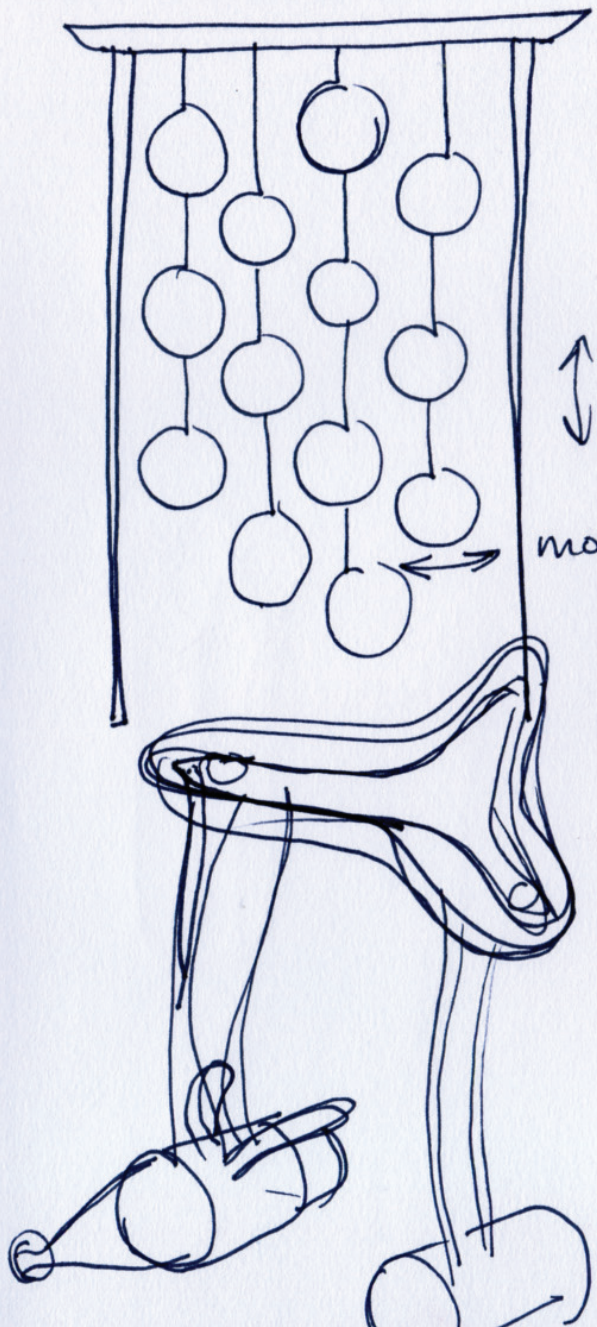

↑ movement/  
stretch.  
↔ movement

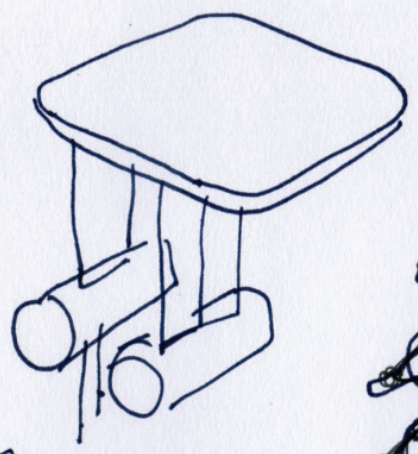

Wine racks.

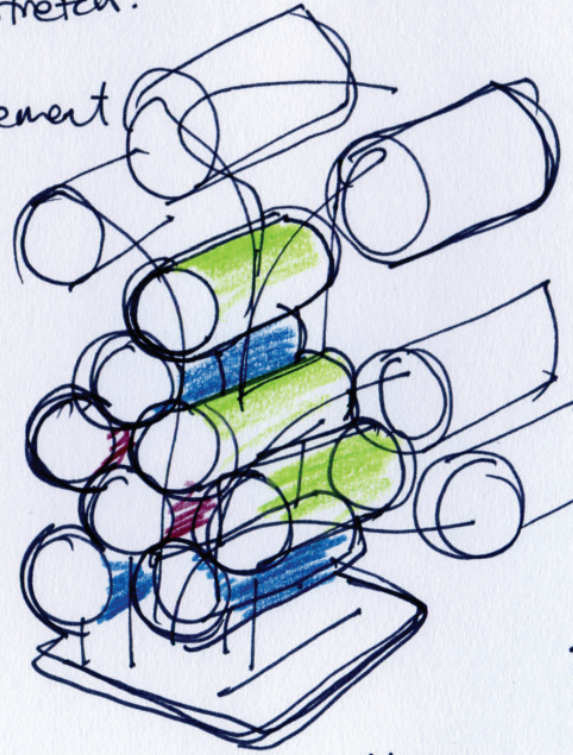
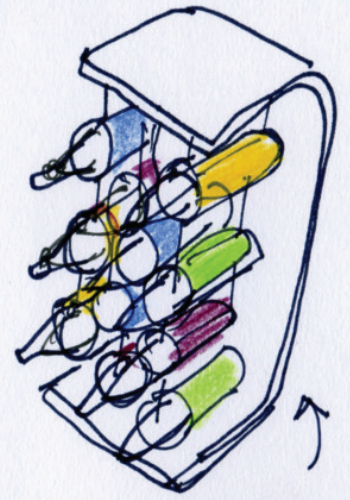

Floating Colour. palette  
of tubes.

Wine  
tree

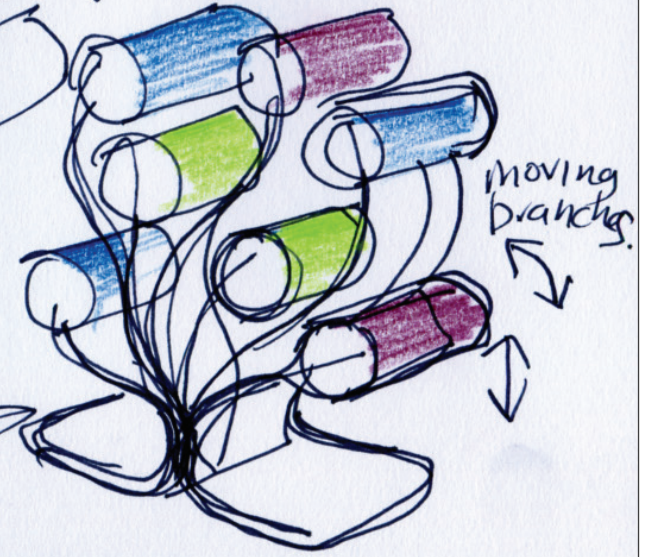

moving  
branches

16 February 2010 © Jason Klenner

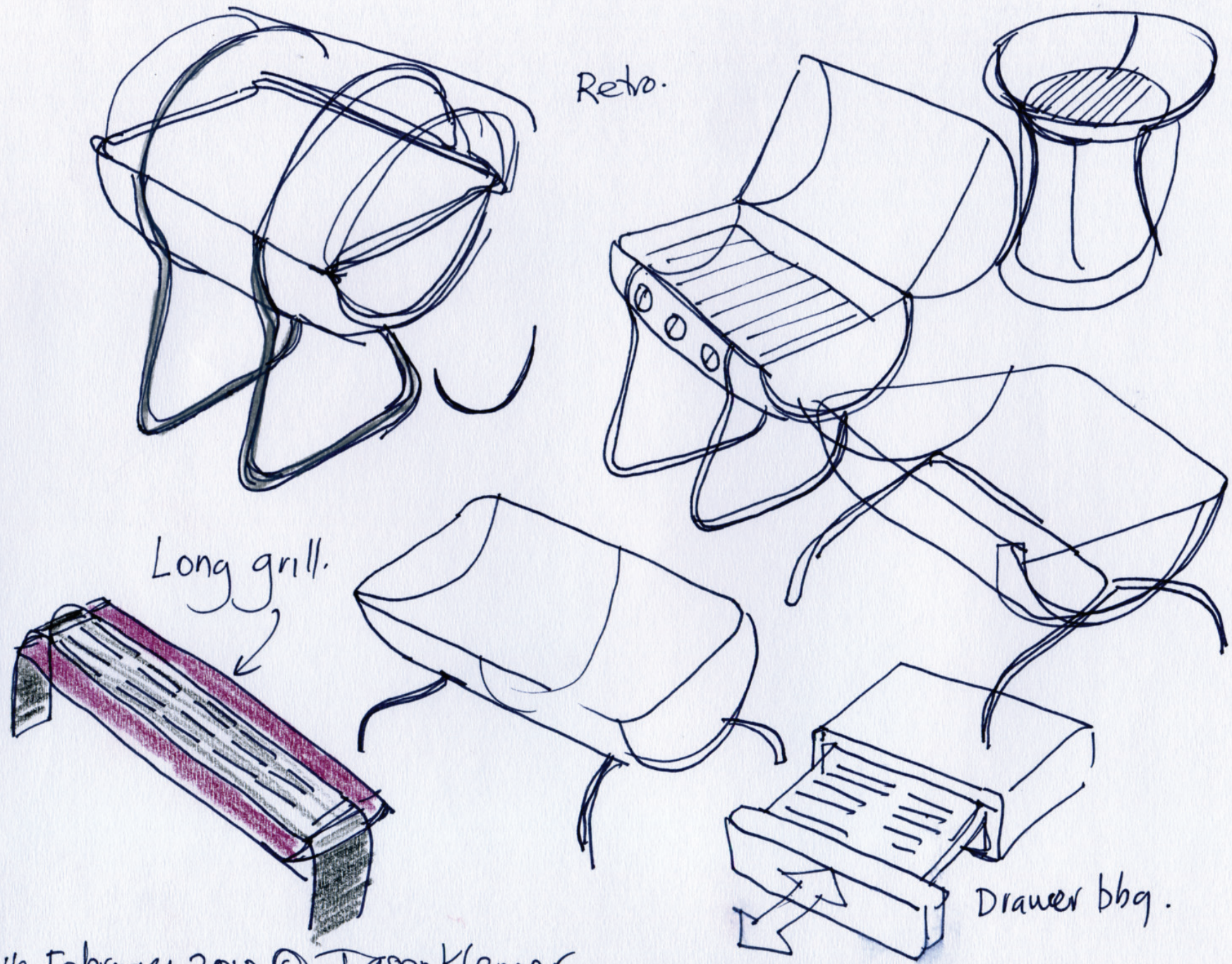

Retro.

Long grill.

Drawer bag.

16 February 2010 © Jason Klenner

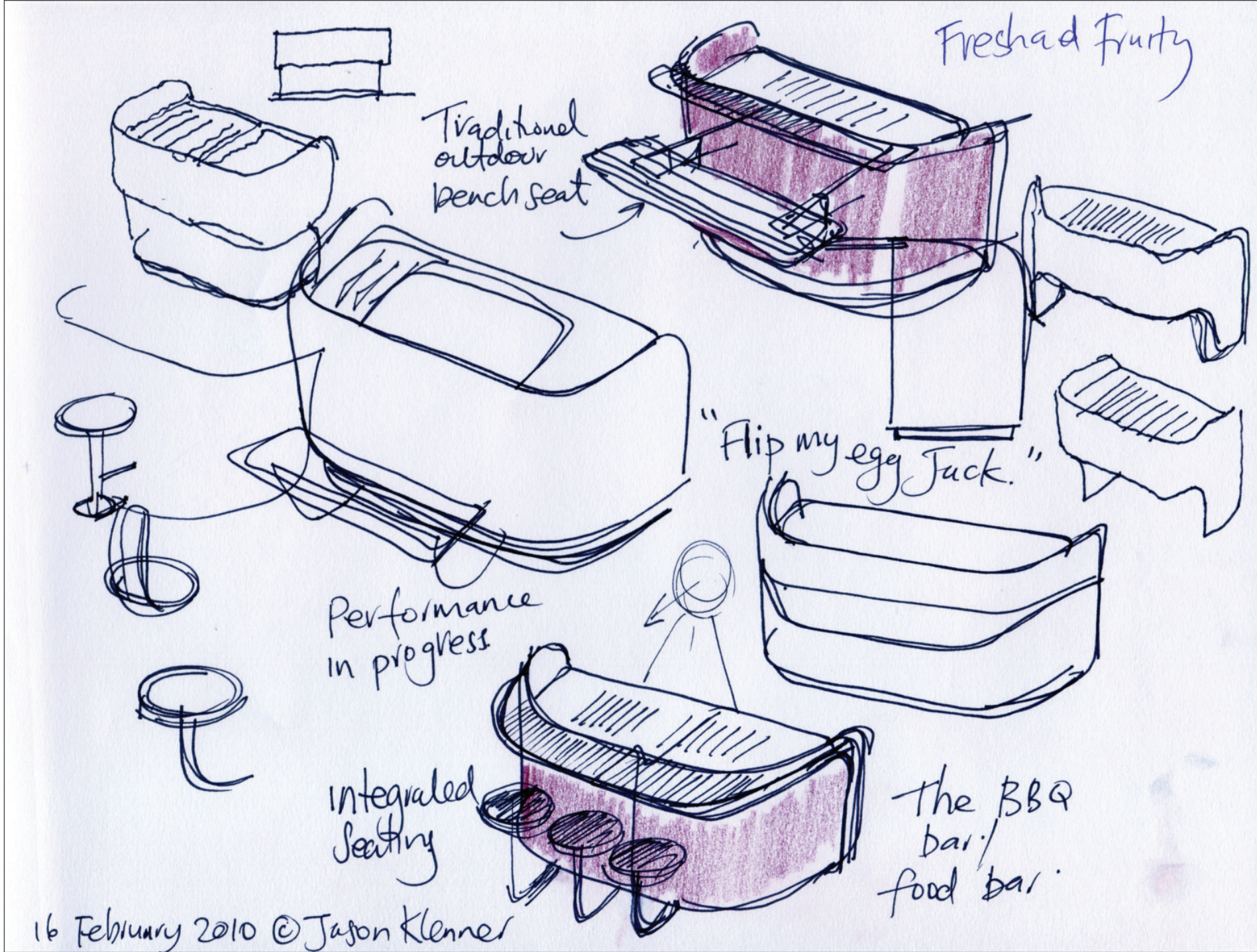

16 February 2010 © Jason Klenner

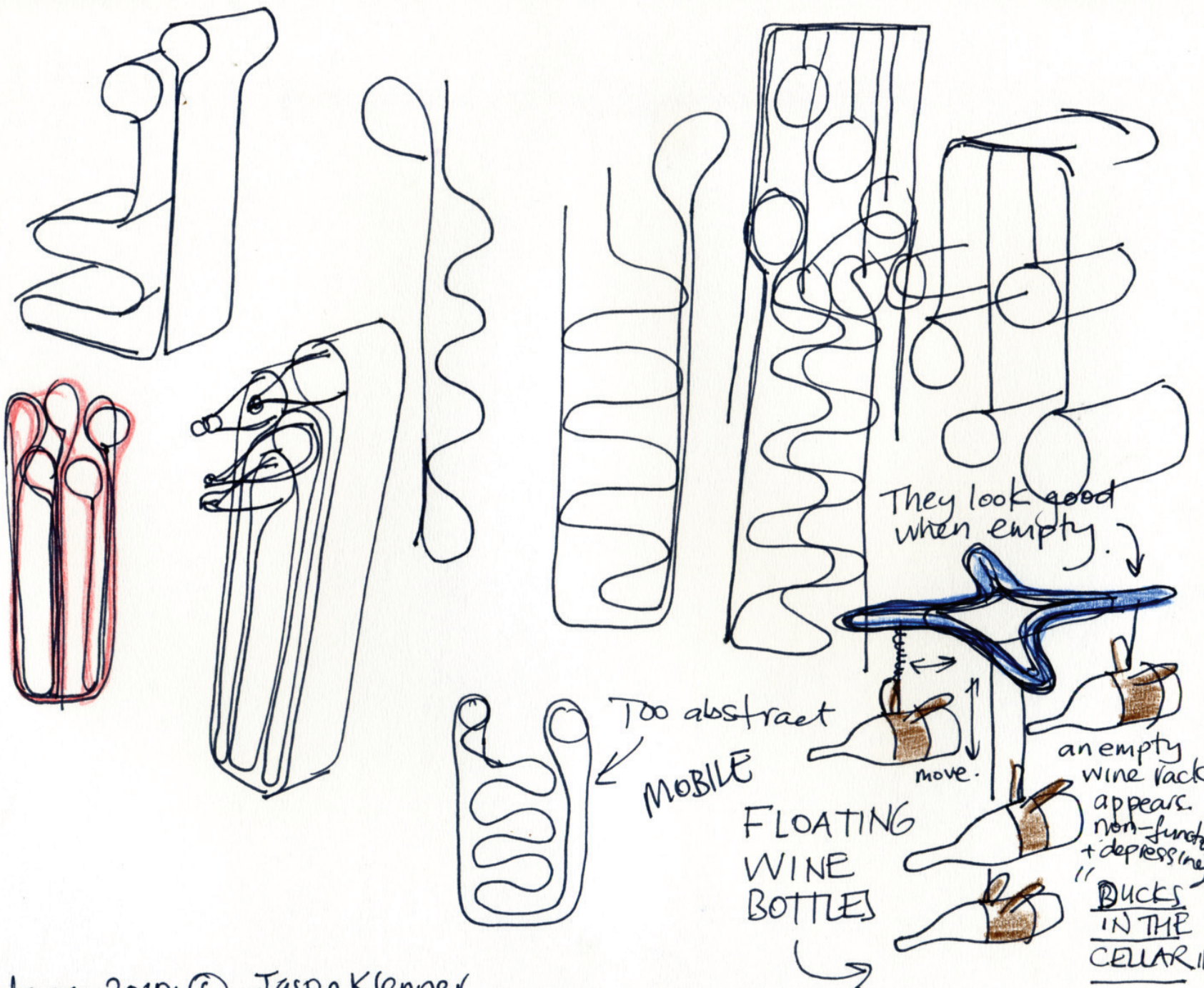

16 February 2010. © Jason Klenner

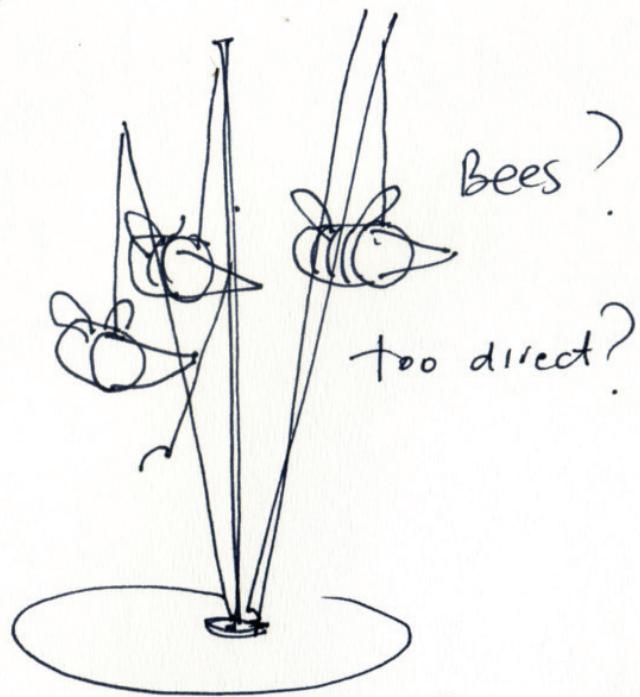

Bees?

too direct?

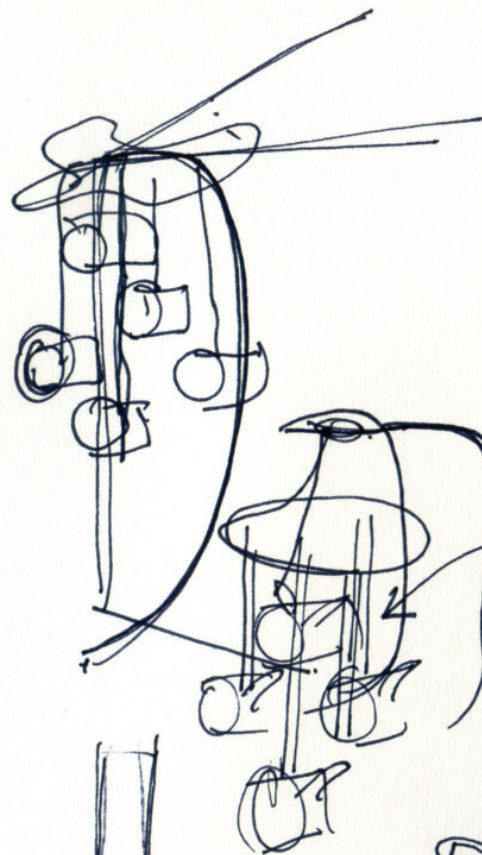
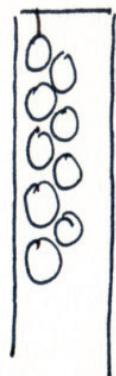

Sold as  
Singles?

they  
need  
space/  
"presence"

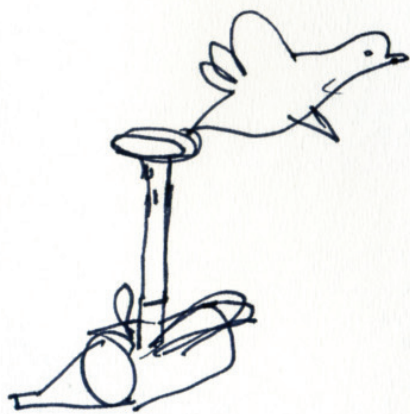

Ducks.

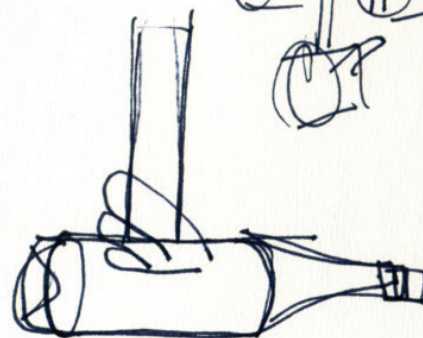
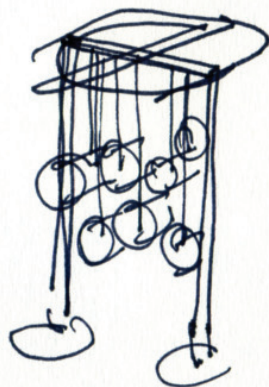

Falls out? ↙ ↗

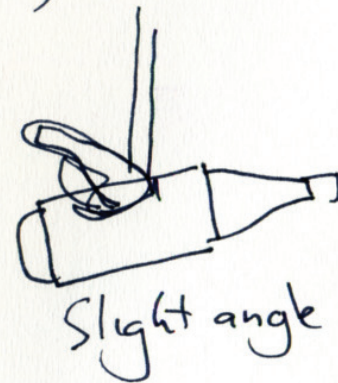

Slight angle?

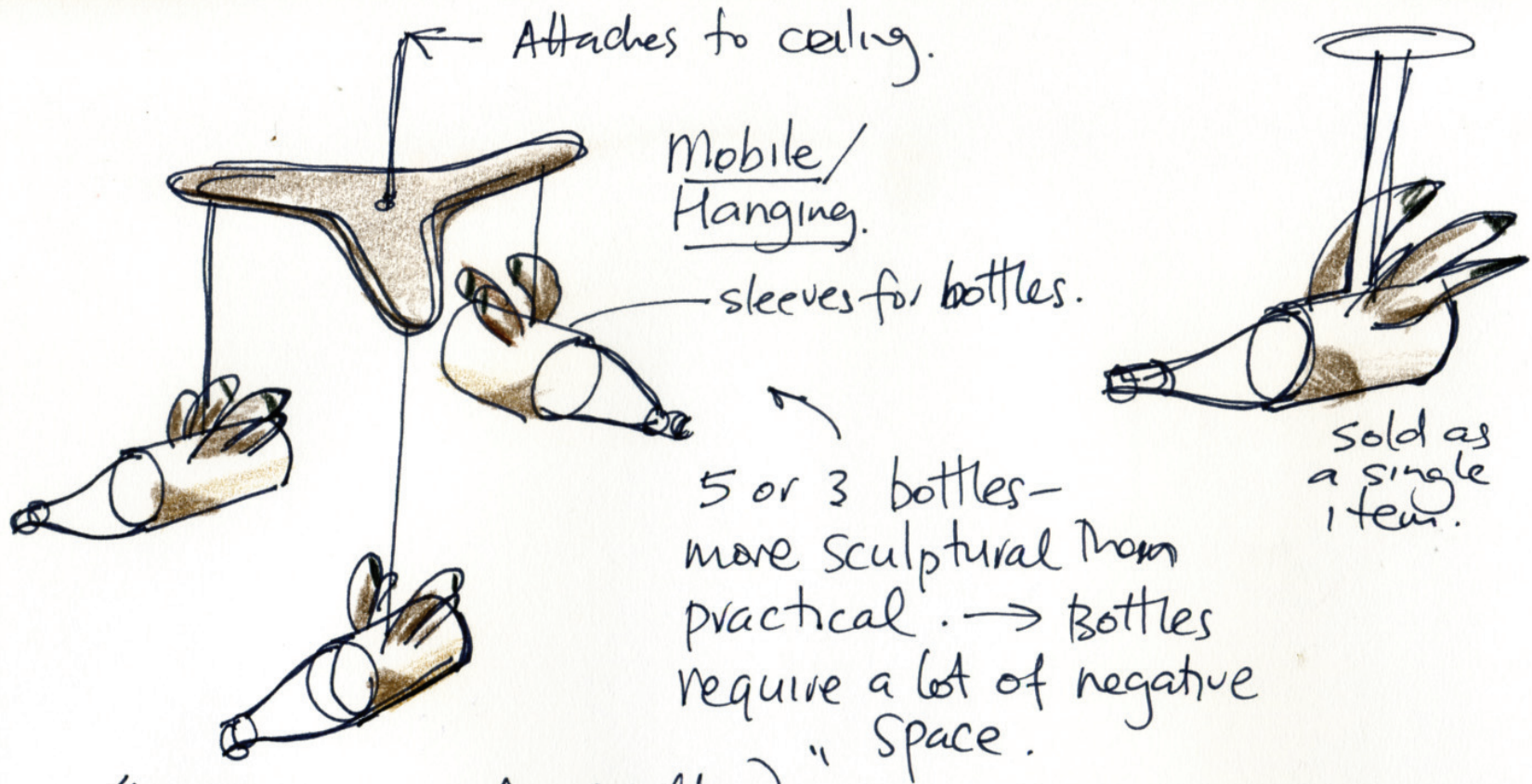

"Entertainment for Adults"



light hearted.  
Nostalgic.

16 February 2010 - © Jason Klenner

Eat as you Cook  
Small modest size.

# "Galbi BBQ"

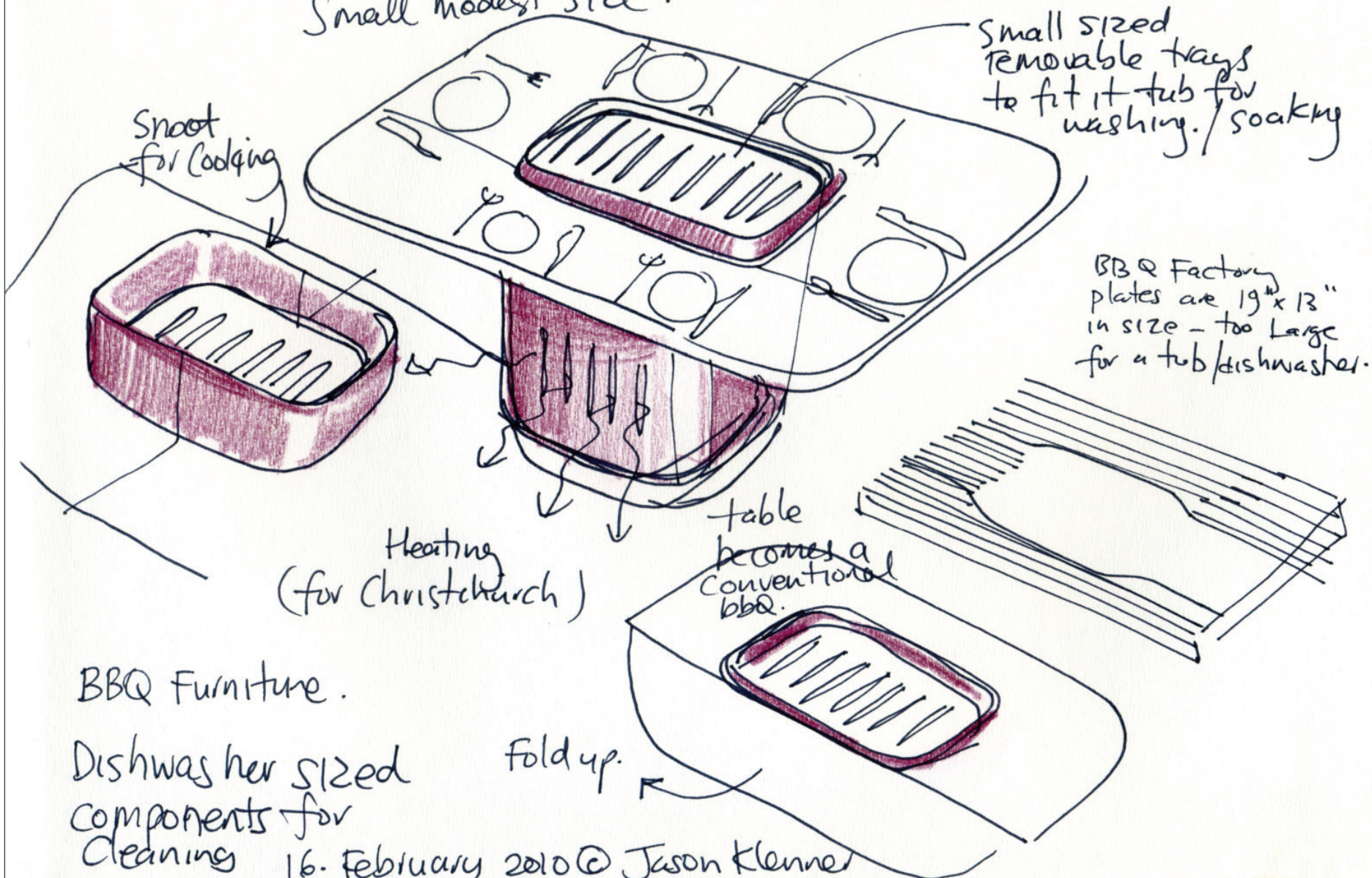

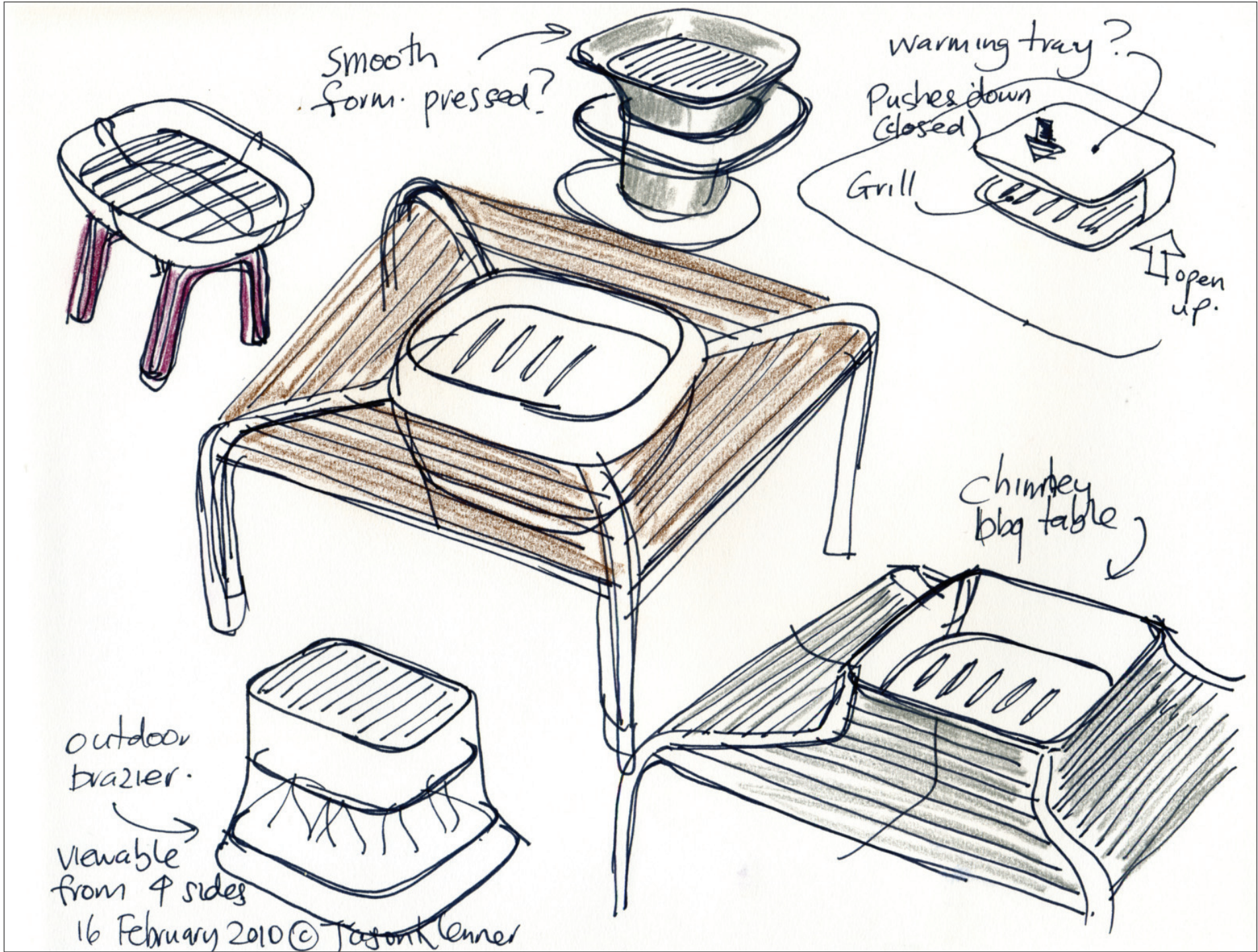

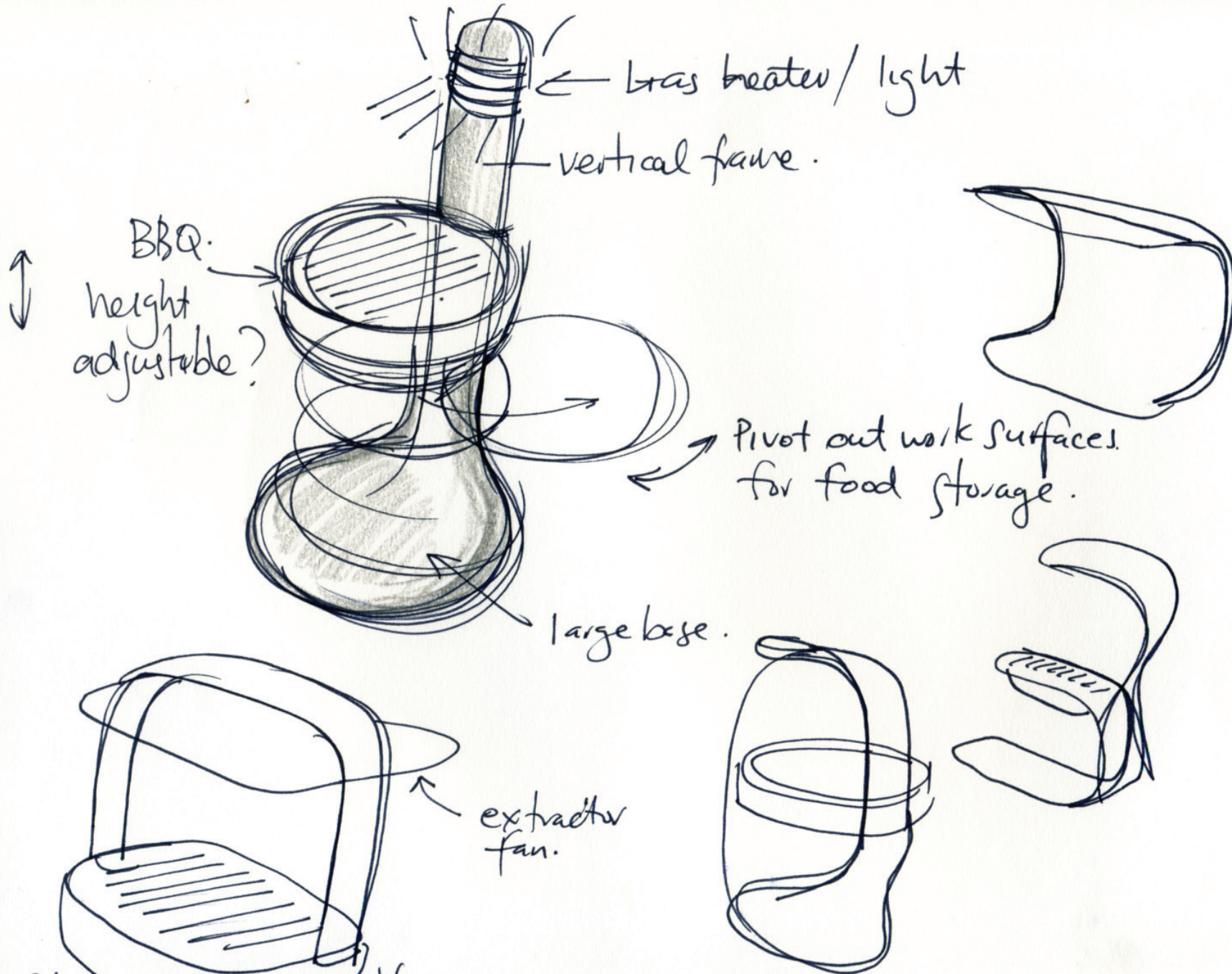

16. February 2010 © Jason Klenner

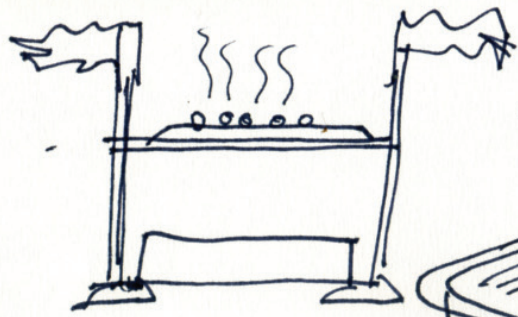

← Stage Theatre.

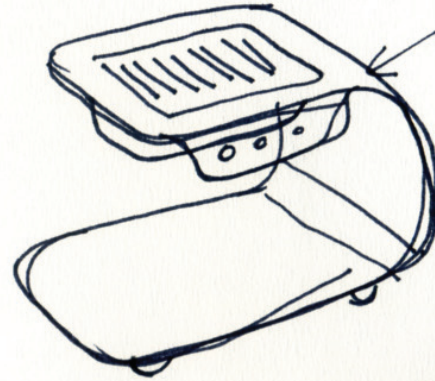
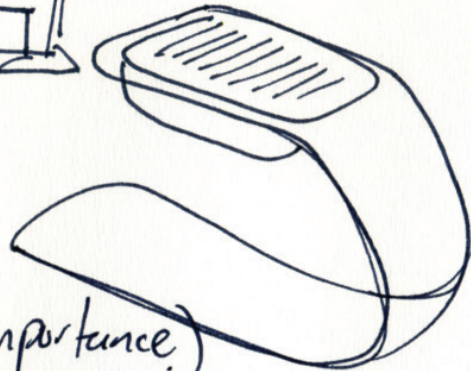

5mm steel.  
Rust finish

Raised  
plinth (sense of importance)

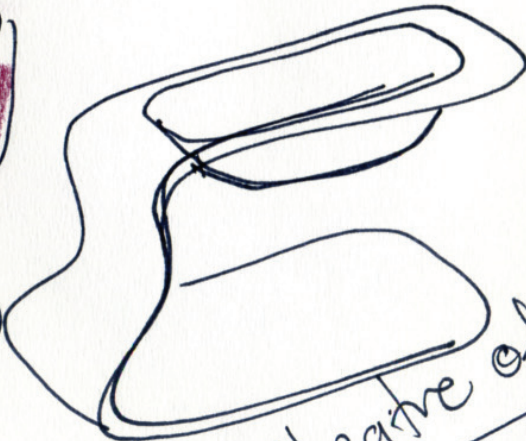
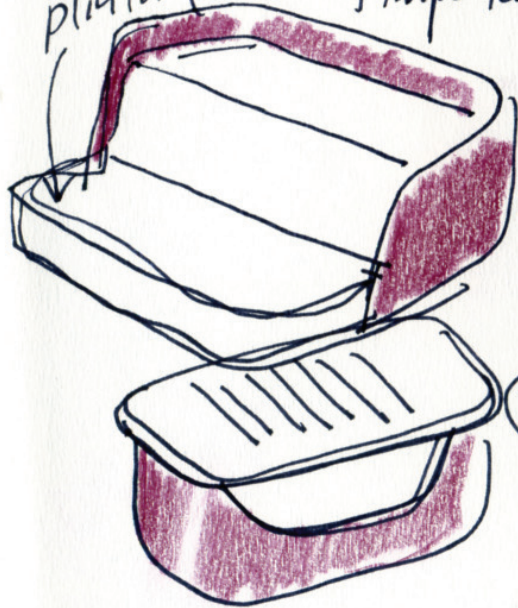

" The theatre of food."

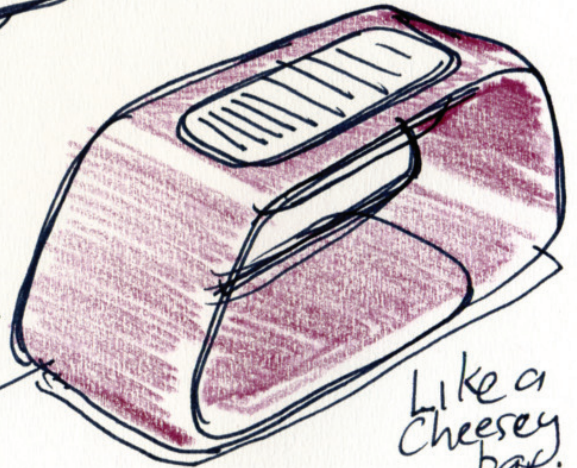

Like a  
Cheesey  
bar.  
vinyl  
back  
front

Audience  
Back hers.

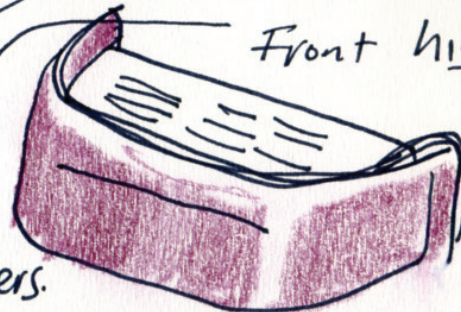

Front his

Performer

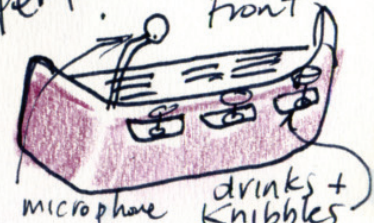

drinks +  
knibbles  
microphone

16. February 2010 © Jason Klenner

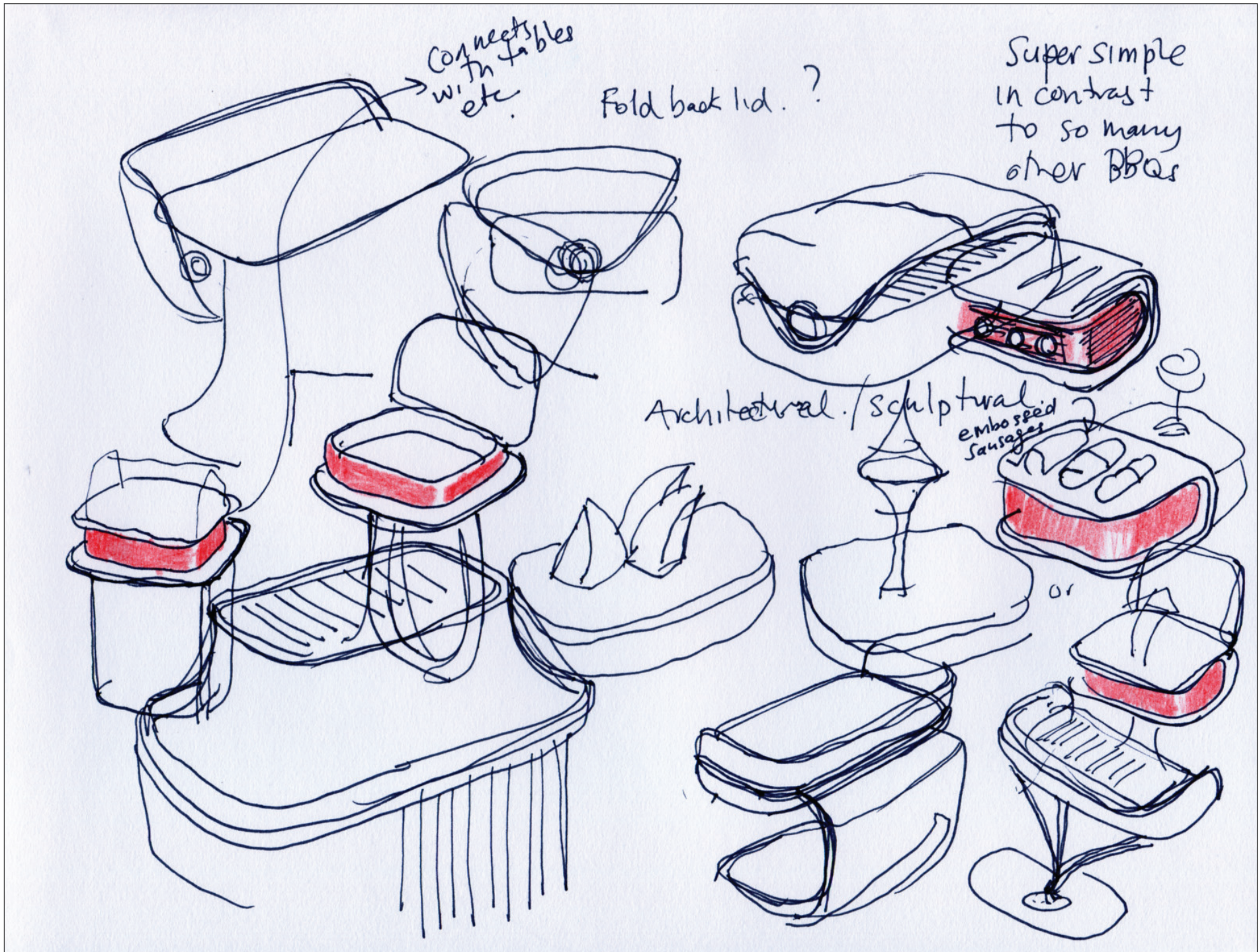

Connects with tables etc.

Fold back lid. ?

Super simple in contrast to so many other BBRs

Architectural / sculptural embossed sausage

or

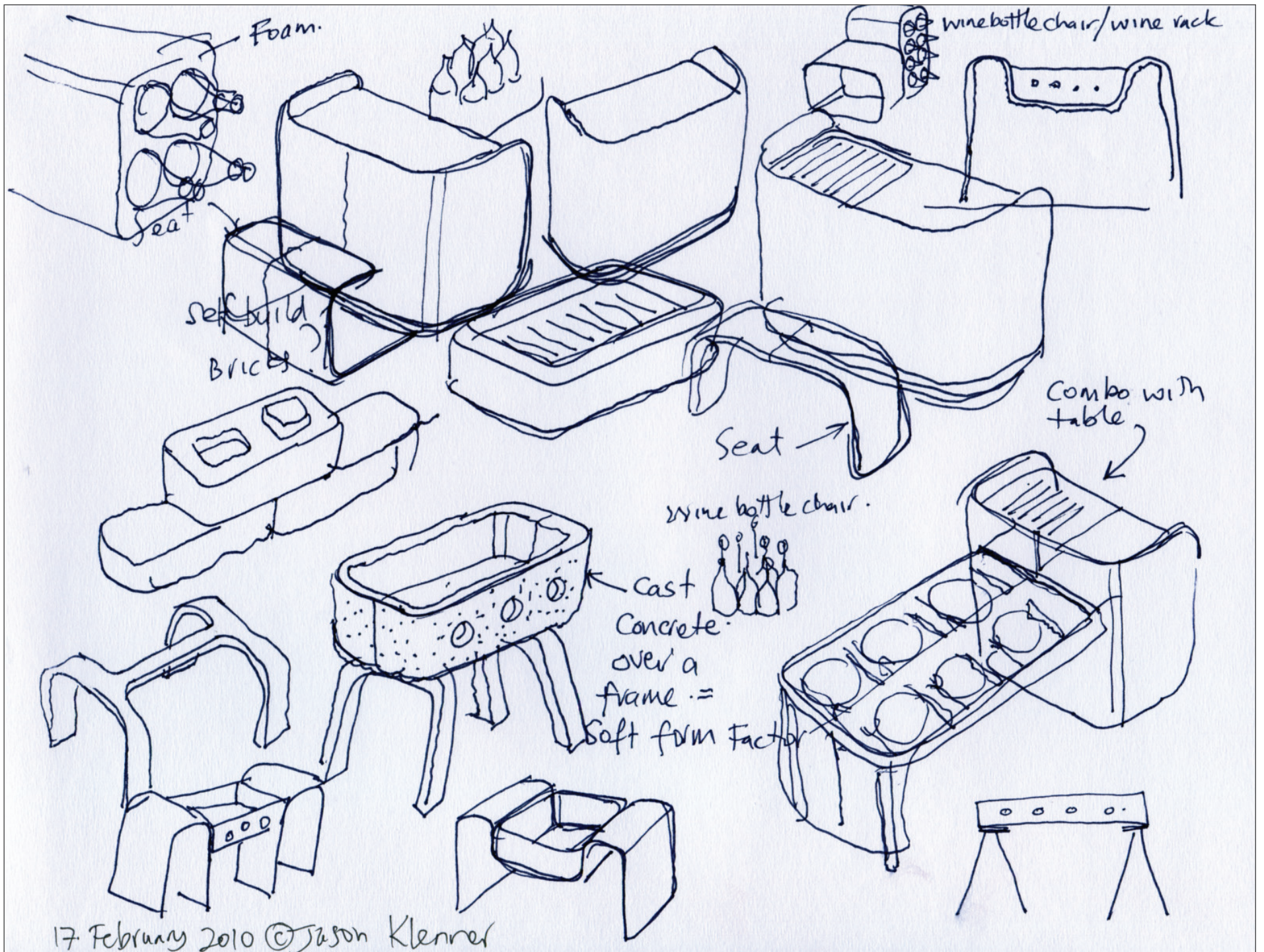

17 February 2010 © Jason Klenner

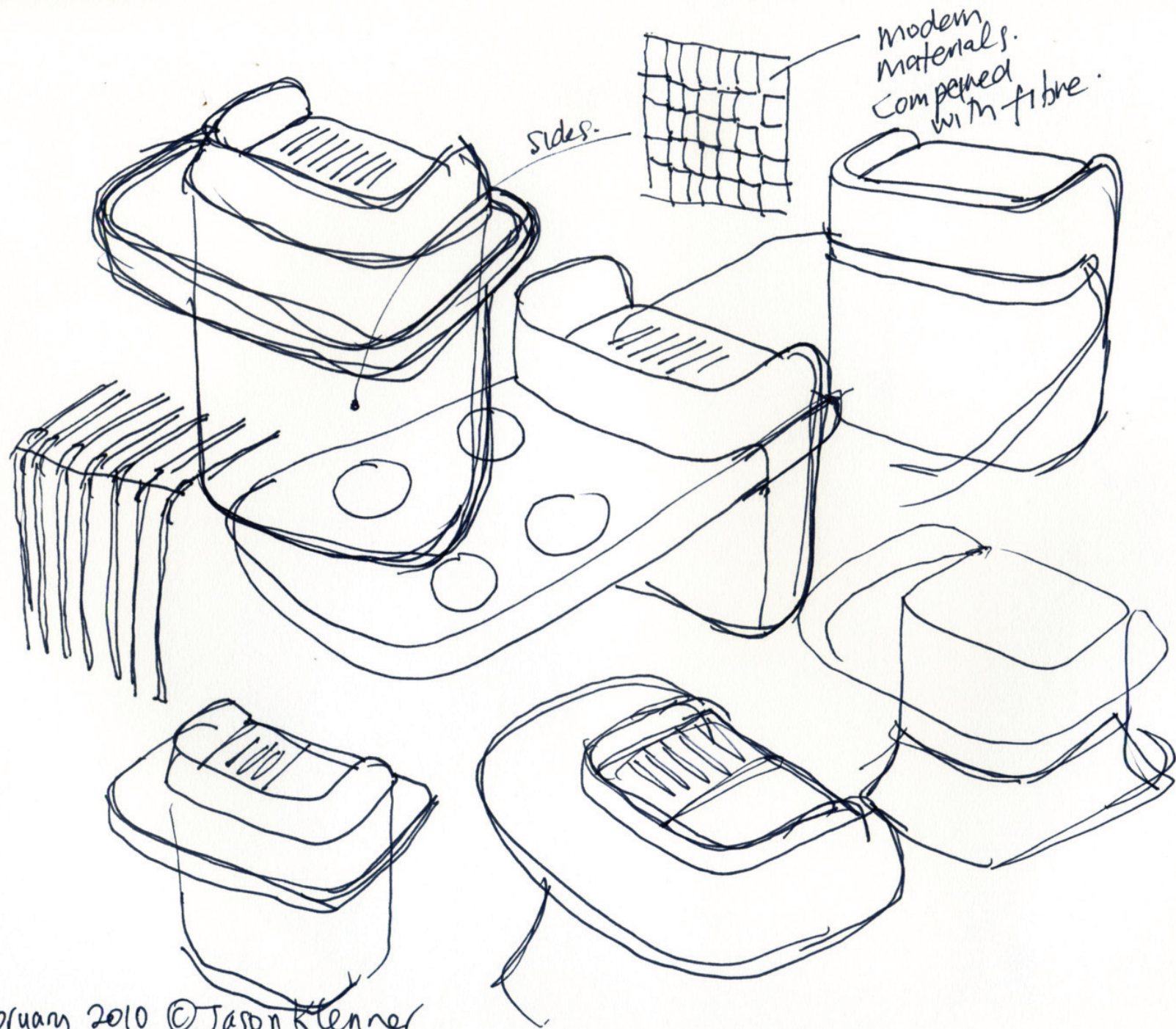

18 February 2010 © Jason Klenner

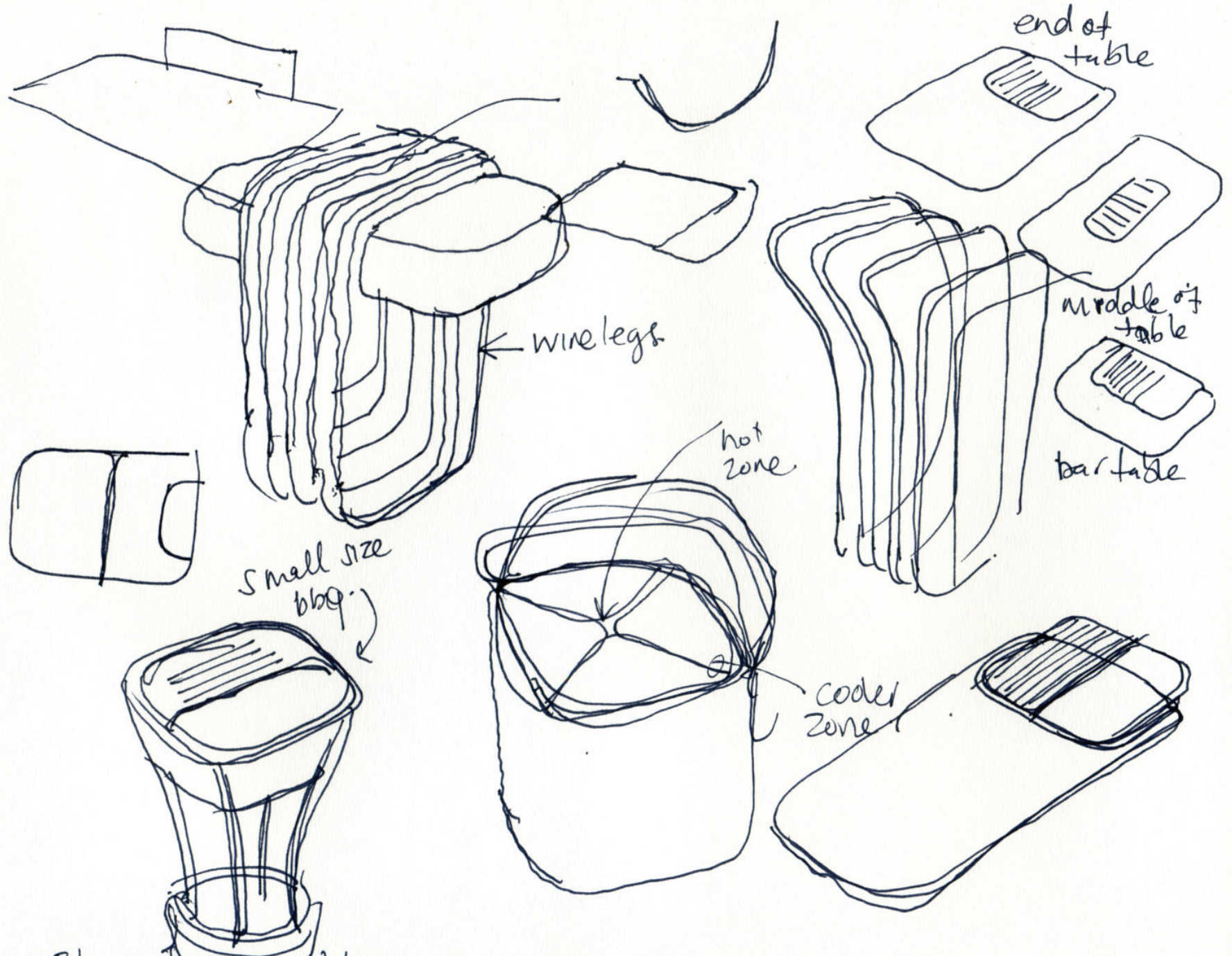

19 February 2010 @ Aaron Klemmer

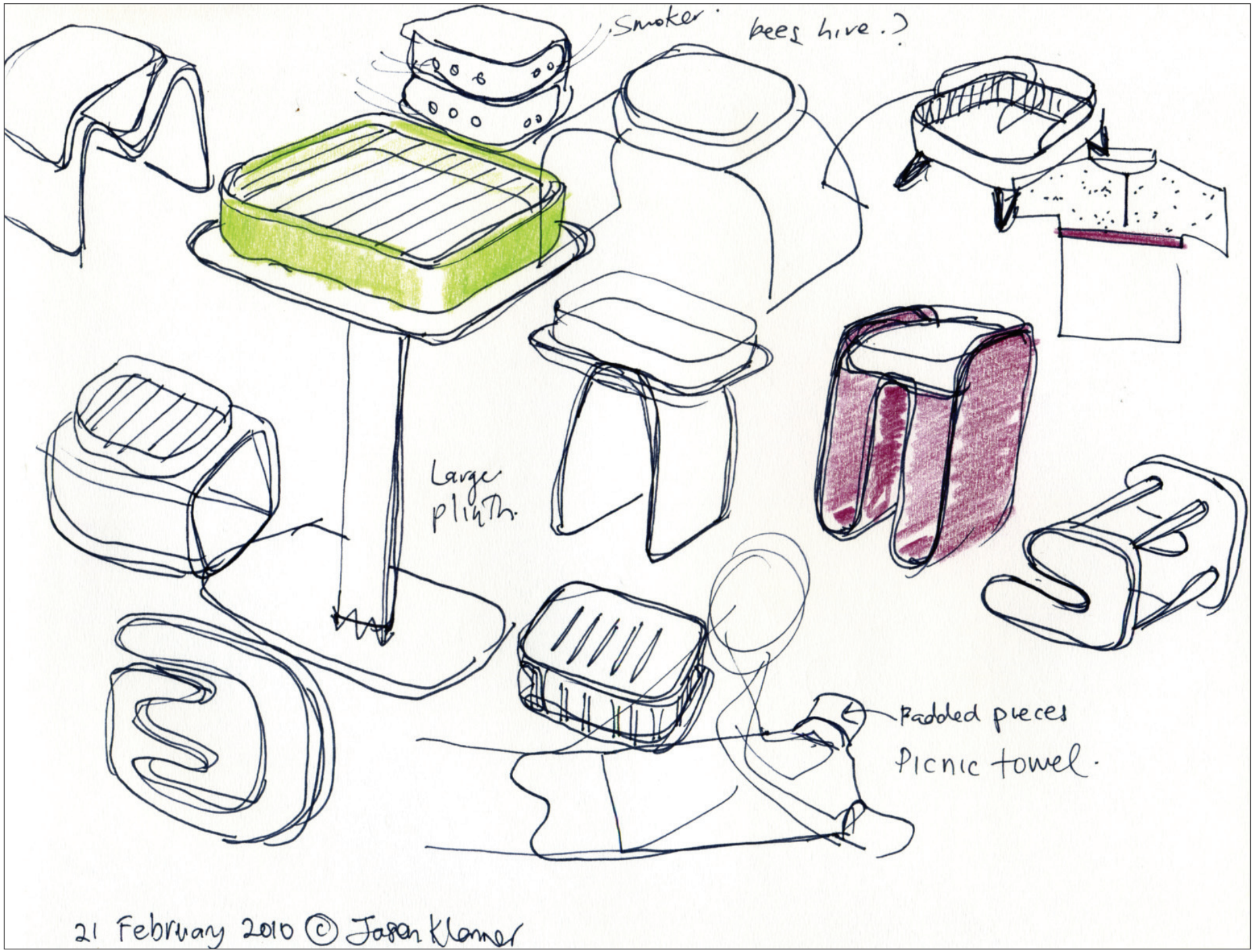

21 February 2010 © Jason Klamer

ROCK AND  
ROLL  
DRUM KIT  
BBQ.

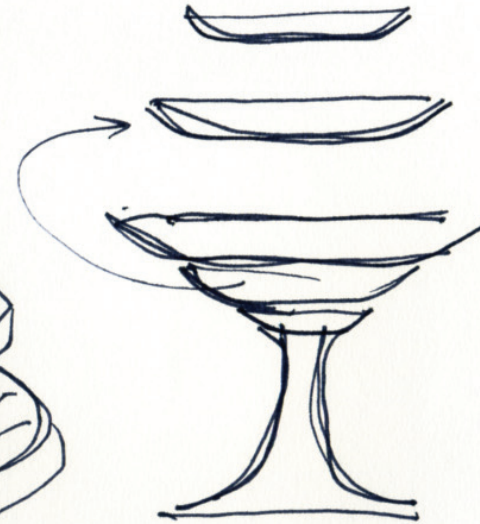
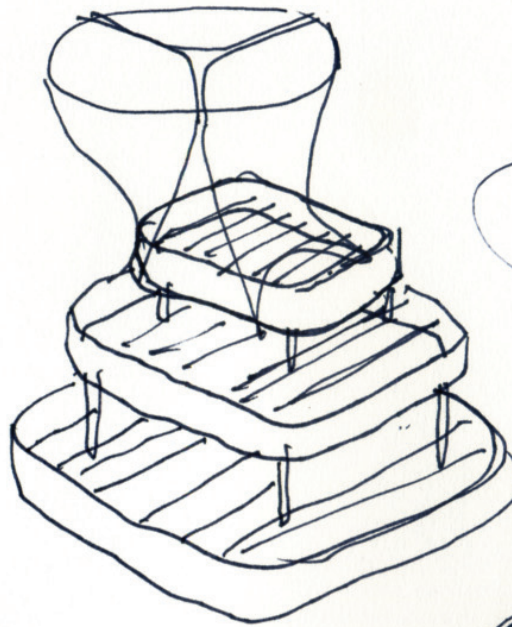
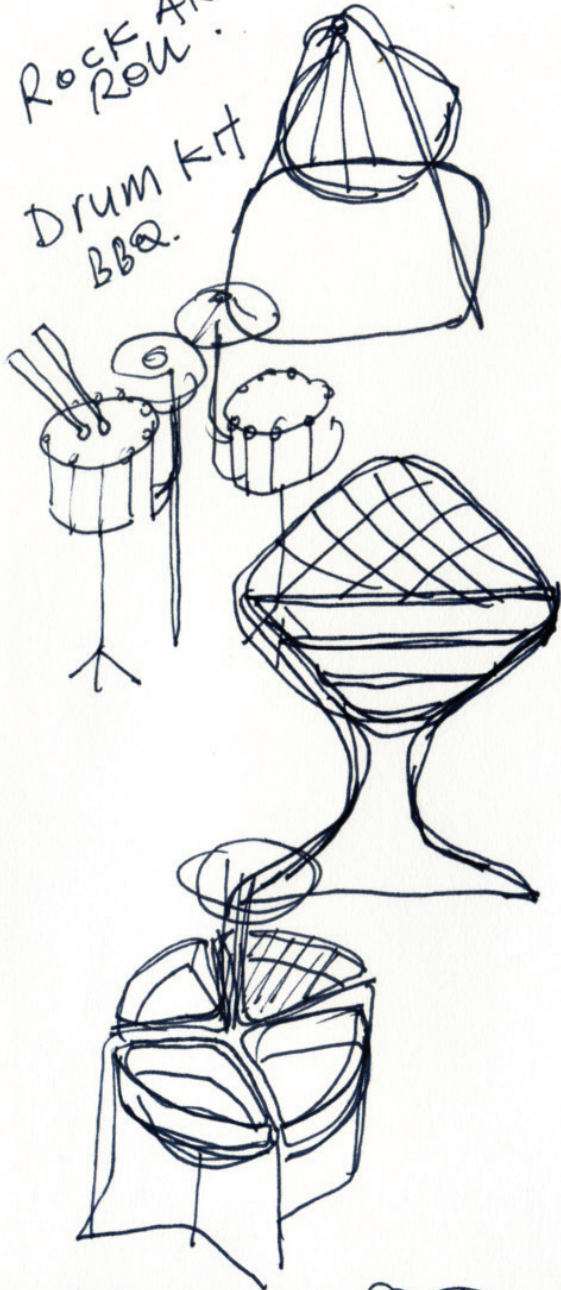

Space van  
BBQ.

Super bulb  
Form.

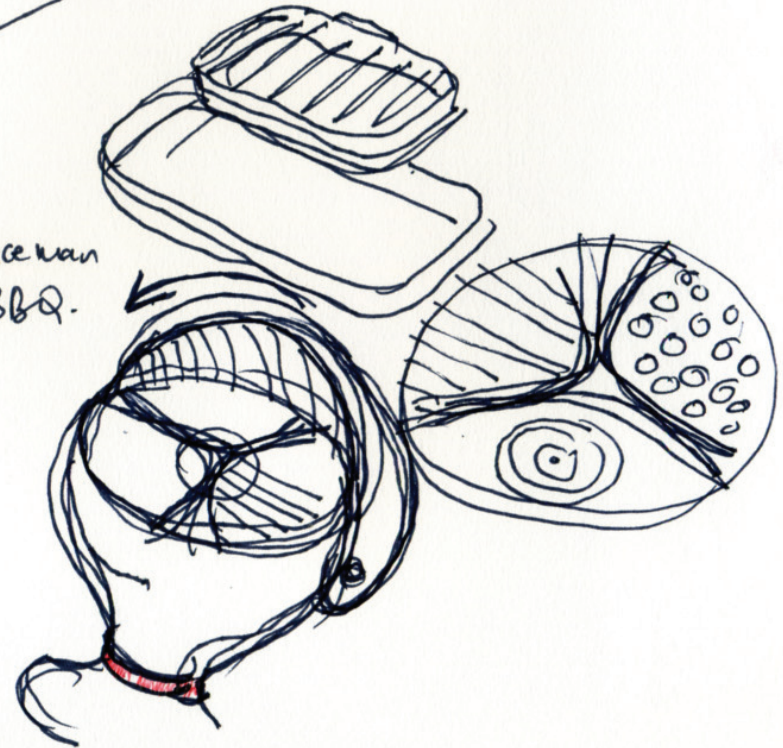

22 February 2010 © Jason Klenner

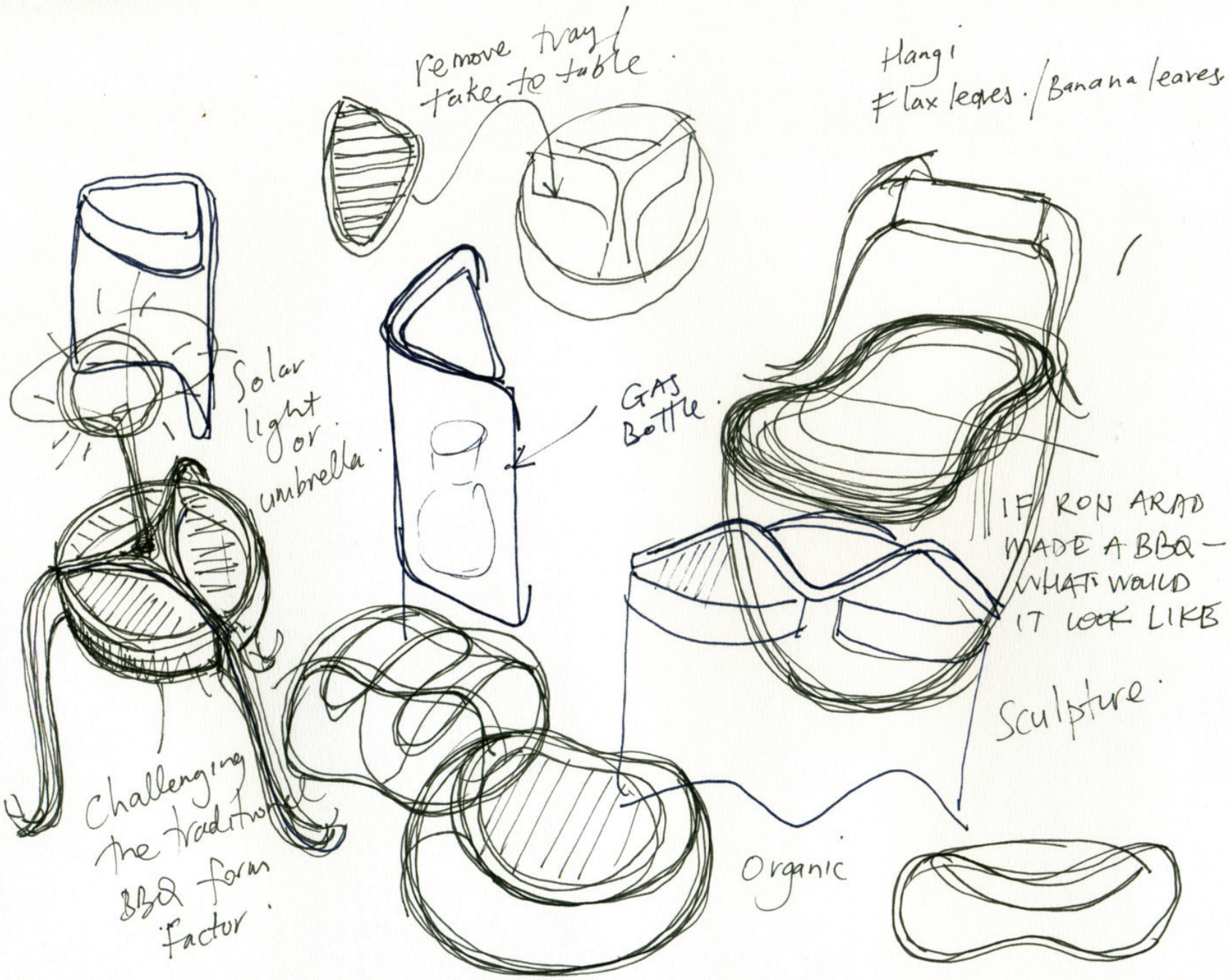

27.02.2010 © Jason Klemmer

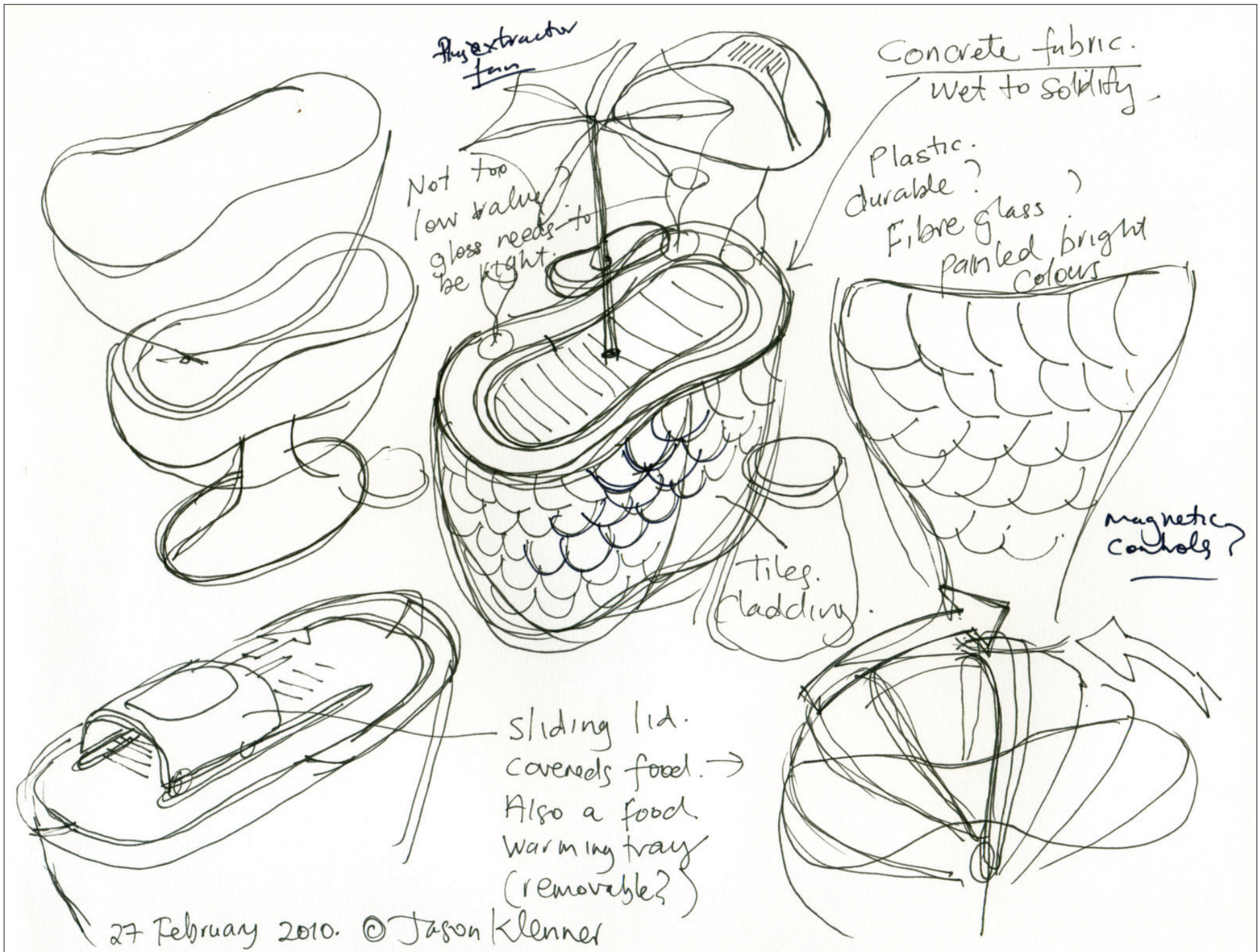

27 February 2010. © Jason Klenner

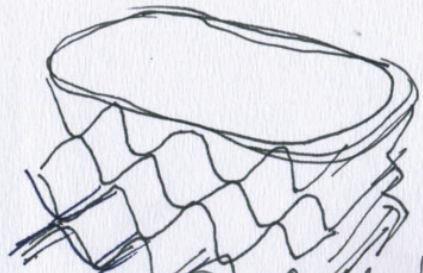

Easy way of forming a solid shape.

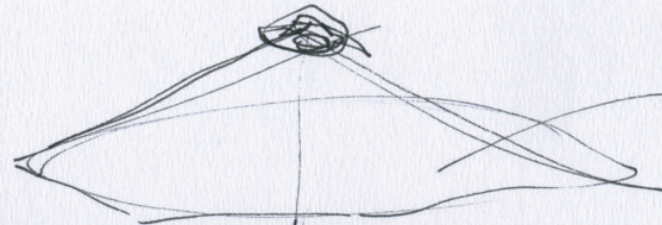

heat from BBQ? too much

Easy to clean  
Continuous form

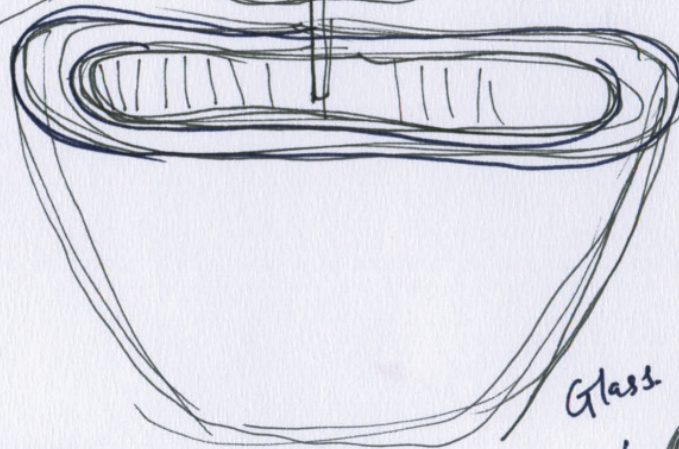
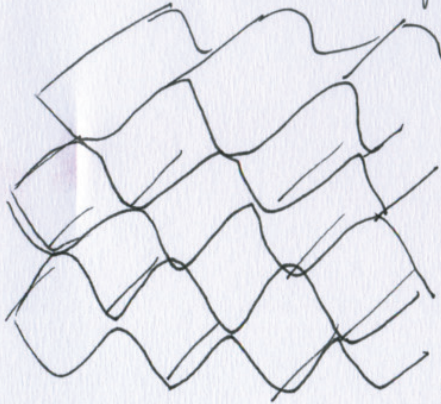
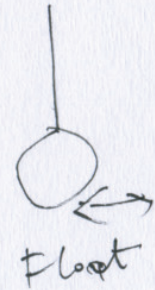

"cooler"

Wine glass floating

Wire stand.

No base:  
Wine glass must be placed back in stand.

Glass

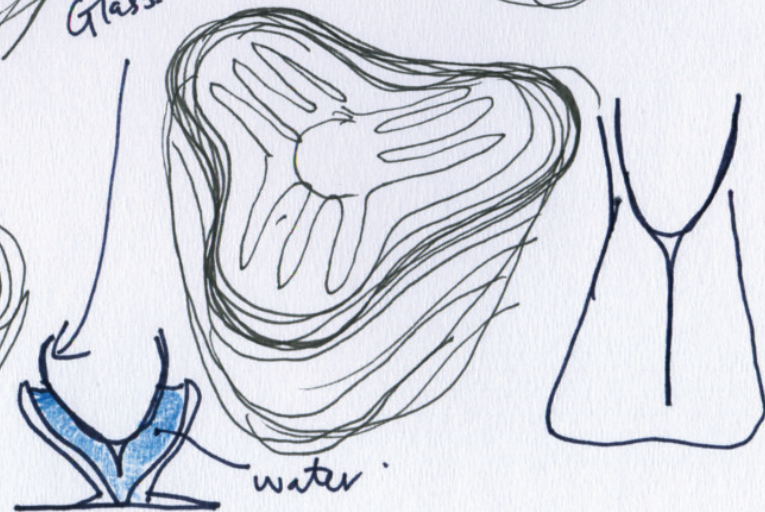
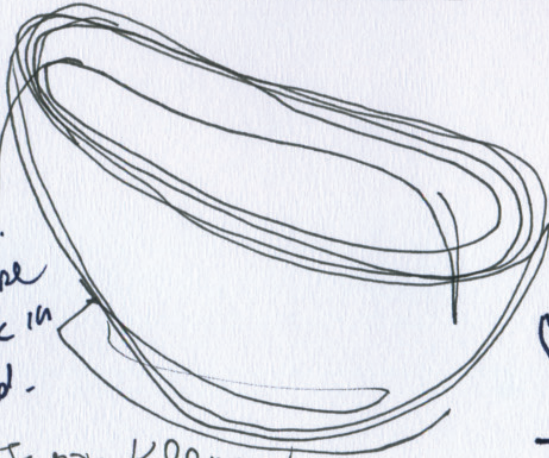

water

27 February 2010 © Jason Klennel

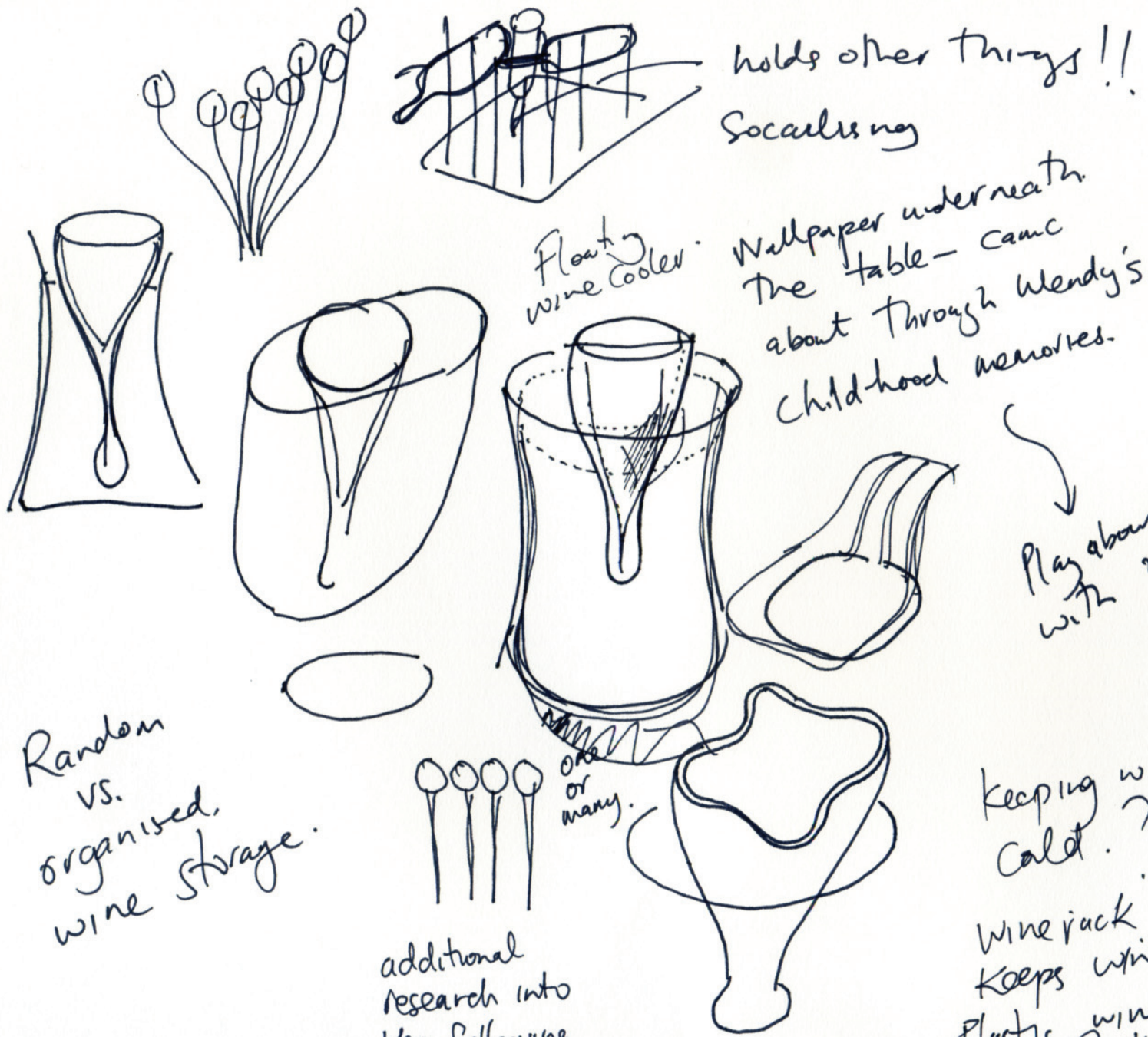

holds other things!!  
Socialising

Floating wine cooler.

Wallpaper underneath the table - came about through Wendy's childhood memories.

Play about with 30

Random vs. organised wine storage.

one or many.

Keeping wine cold. ??  
Wine rack that keeps wine cold. Plastic wine bottles and their role on wine racks

additional research into the following areas:

1 march 2010: © Jason Klenner

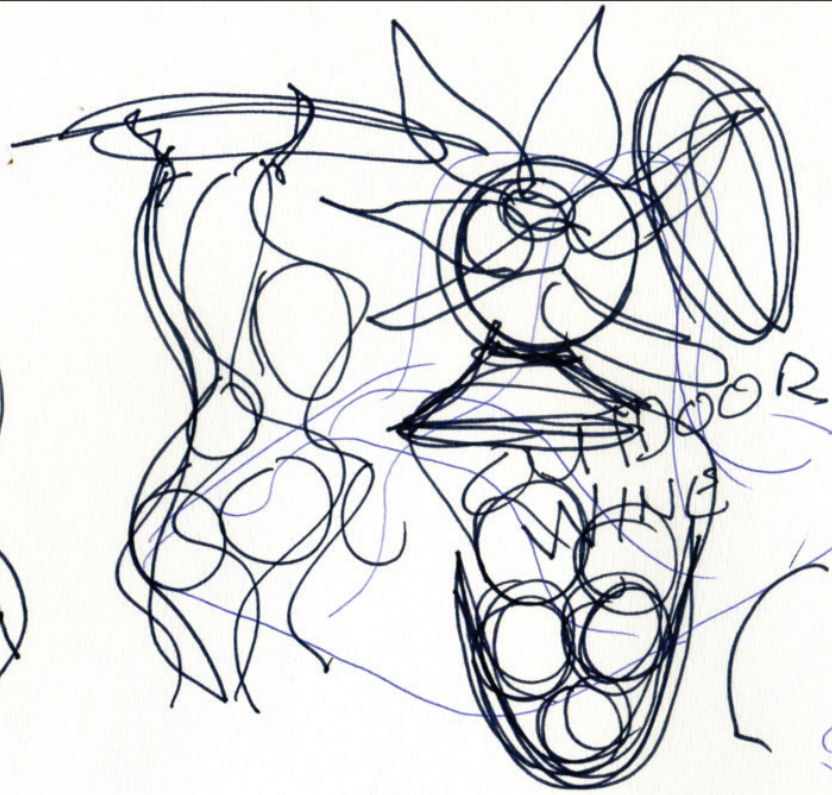

Clusters  
1.

domestic space  
outdoors



perhaps sometimes  
that fit together  
as a collection of things....  
The base  
being carpet



## Critical Reflection: (Based on "The Zone")

### Pros:

- New form factor.
- No front/back of BBQ.
- Socialable form factor.
- High Value? Limited edition possibilities.
- Could incorporate umbrella/extractor fan.
- Holiday/Club med. feeling.
- Simplified the bbq into a new form. (all current bbqs look the same)

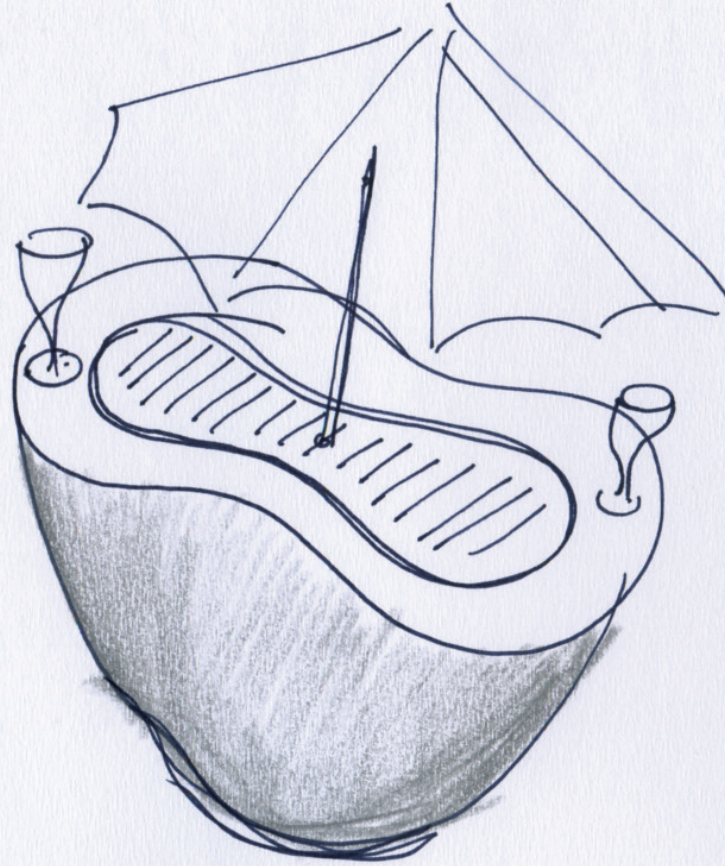

"BBQ ISLAND"

### Cons:

- Too large to exhibit.
- What else would be in the range?
- Art? → this will get dirty - will it still be art?
- Too many functional requirements.

6 March 2010 © Jason Klenner

## Critical Reflection: (Based on "The Zone")

### Pros:

- Captures NZ bbq personality.
- Could be a larger/modular system.
- Could incorporate under table heating.
- Modules could include:
  - Coal pit
  - Gas pit.
  - Flower pit.
  - Lazy Suzy pit.
  - Heater pit.
  - Hot rock.



"Tabletop BBQ"

(Korean Galbi influenced.)

### Cons.

- Too large to exhibit/show
- Only one item. - one large item.
- Too many functional requirements.
- Do people really want to bbq at their table - especially if it starts to rain.
- a serious purchase.
- Limited edition/art?
- Does this go against the traditional kiwi bbq culture? - (man cooking with nites)
- where is the NZ style.
- Gas = Low value?
- Coal = High maintenance.

6 march 2010. © Jason Klenner.

# Critical Reflection: (Based on "The Zone")

## Pros:

- Unique./ Distinctive.
- Strong personality - good for a Art based piece.
- Good for limited edition possibilities
- Fun. light hearted.

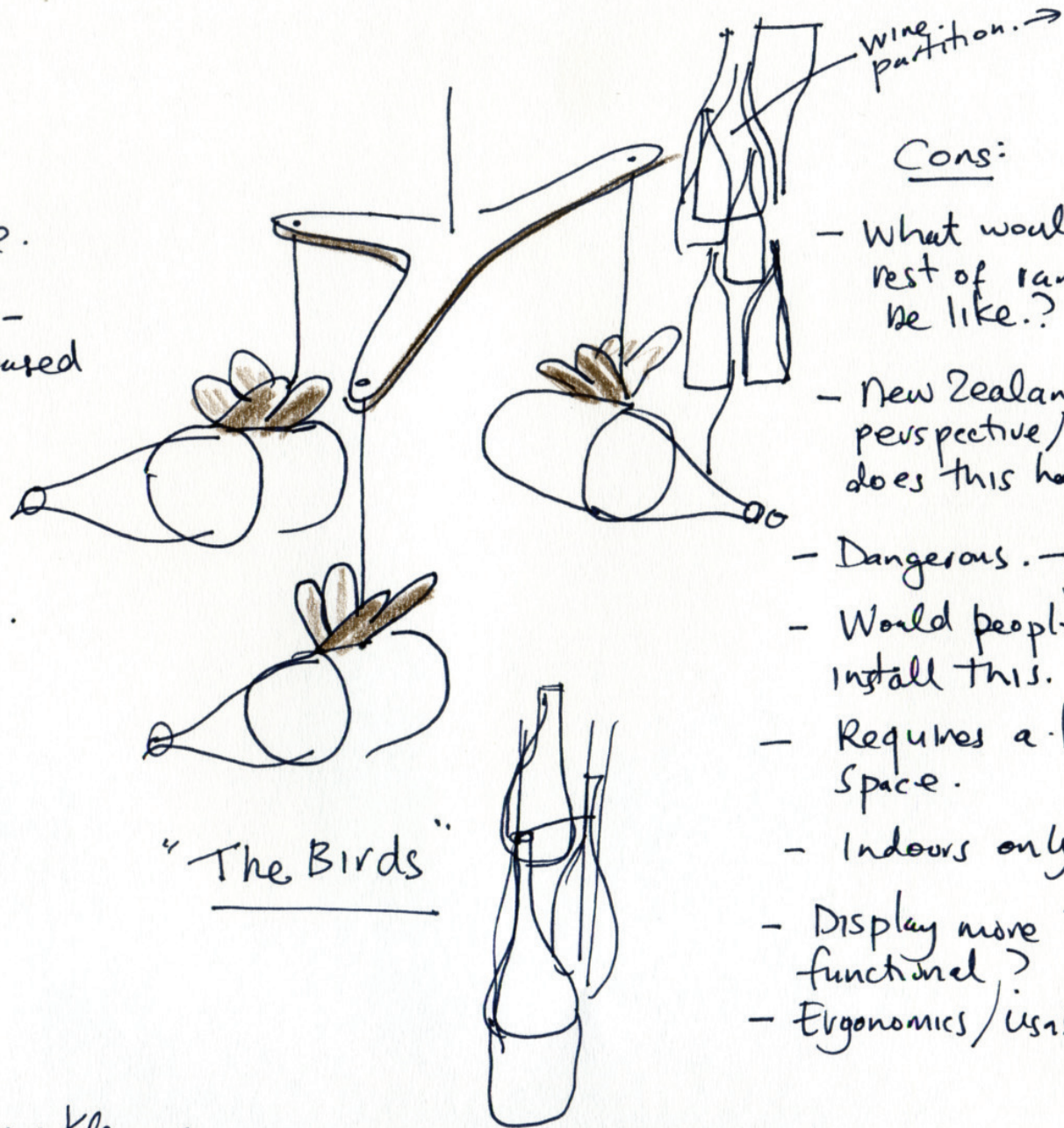

## Cons:

- What would the rest of range be like.?
- New Zealand perspective/angle - does this have one.?
- Dangerous. - hanging glass..
- Would people install this.
- Requires a lot of space.
- Indoors only.
- Display more than functional.?
- Ergonomics/ usability.?

6 March 2010 © Jason Klenner

# Critical Reflection: (Based on "The Zone")

## Pros:

- Interesting ideas of combining wine-related items: bottles and glasses.
- Wine → good topic.
- Good size to display / to have a range.

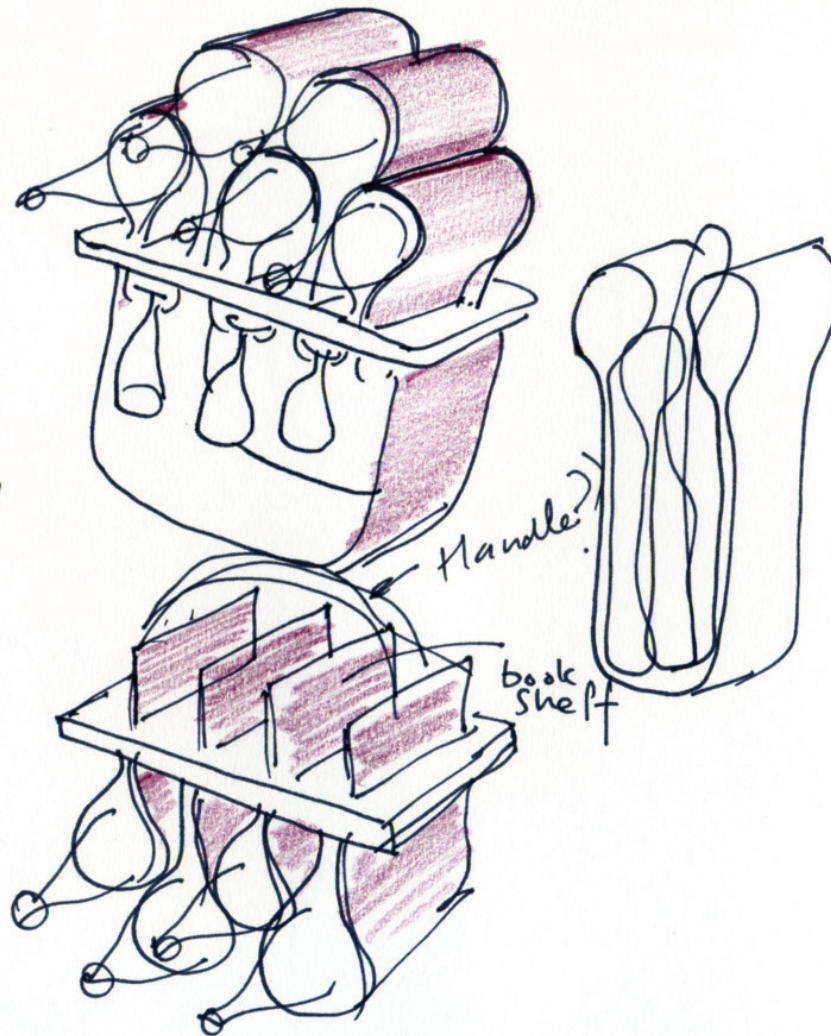

Wine Racks!

## CONS:

- Not light hearted?
- Too functional.?
- Too small. → not high value enough? → where is the art content?
- Object needs <sup>This</sup> presence — cannot be guaranteed.
- Looks like IKEA or Habitat (at best)
- Limited personality
- Too rigid.
- No New Zealand outward story in the form factor.
- Too static. → more information is required about how/why racks are used.
- Indoors only.?

6 March 2010: © Jason Klenner

## Critical Reflection: (Based on "The Zone")

### Pros:

- Idea has good limited edition possibilities
- Can be personalised.
- Idea can be taken to new areas.  
eg. Summer/winter skins.

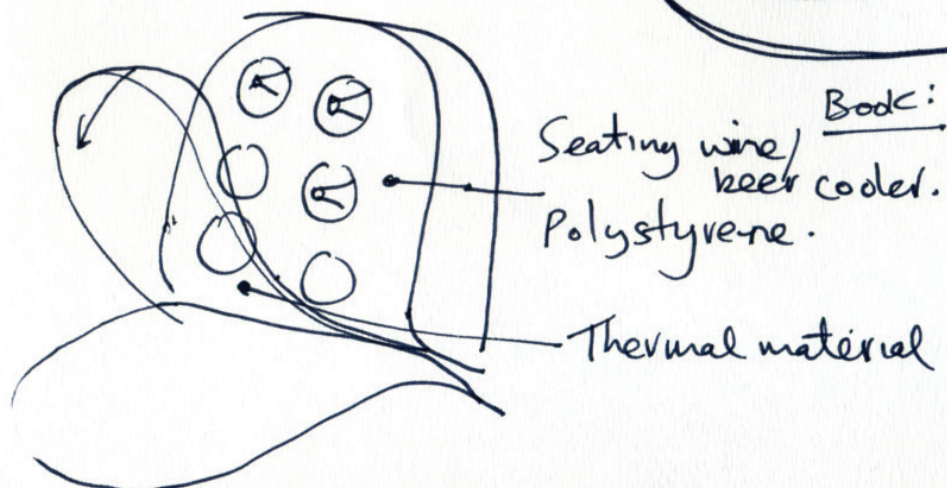
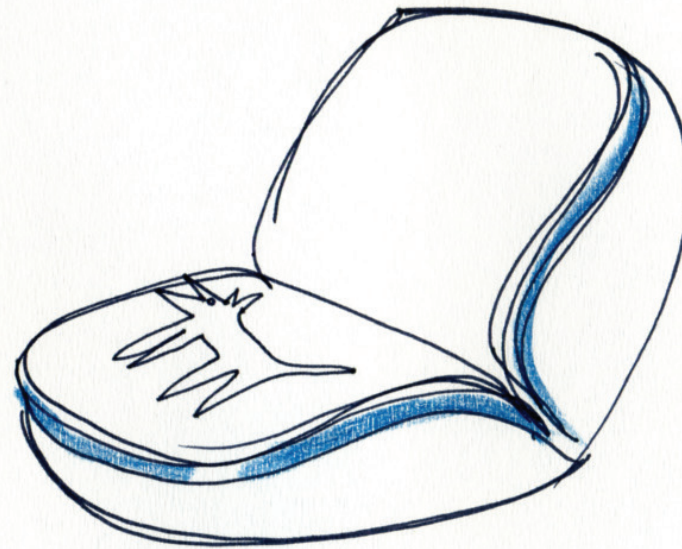

### Cons:

- Idea has been used before - but not exactly in this way.  
(IKEA, ICFP, Jane Atfield)
- Where is the social aspect?
- Current model = big and clumsy
- Indoors or outdoors? not obvious.
- Not linked with New Zealand.
- Not easily linked with a range of products?
- Too much like a regular upholstered piece of furniture.
- It is a chair/seat
- Too mass market?

6 March 2010 © Jason Klenner

## Critical reflection: (Based on 'The Zone')

### Pros:

- Unique./distinctive.
- Easy to develop a range.
- Indoors and outdoors.
- good limited edition possibilities.
- Good. high-value niche possibilities

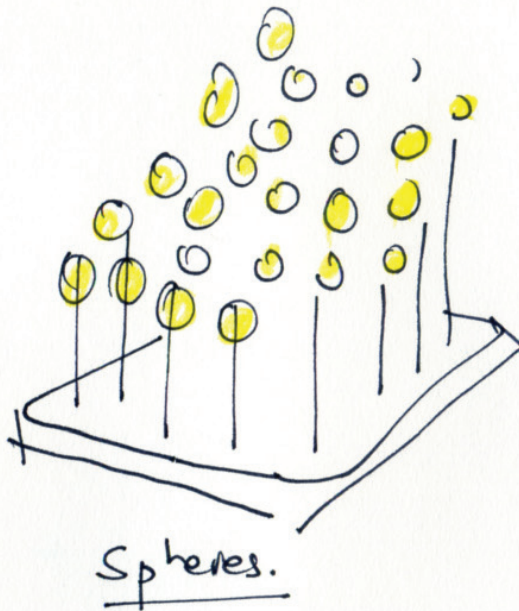

### Cons:

- (Model) is too rigid.
- Not linked with New Zealand.
- Appears 1980s
- Comfort.??
- Indoors or outdoors? not obvious
- It is a chair seat.
- Where is the social aspect.

note: The "chair" needs to be combined with something else to create the "social" aspect.

6 March 2010 © Jason Klenner

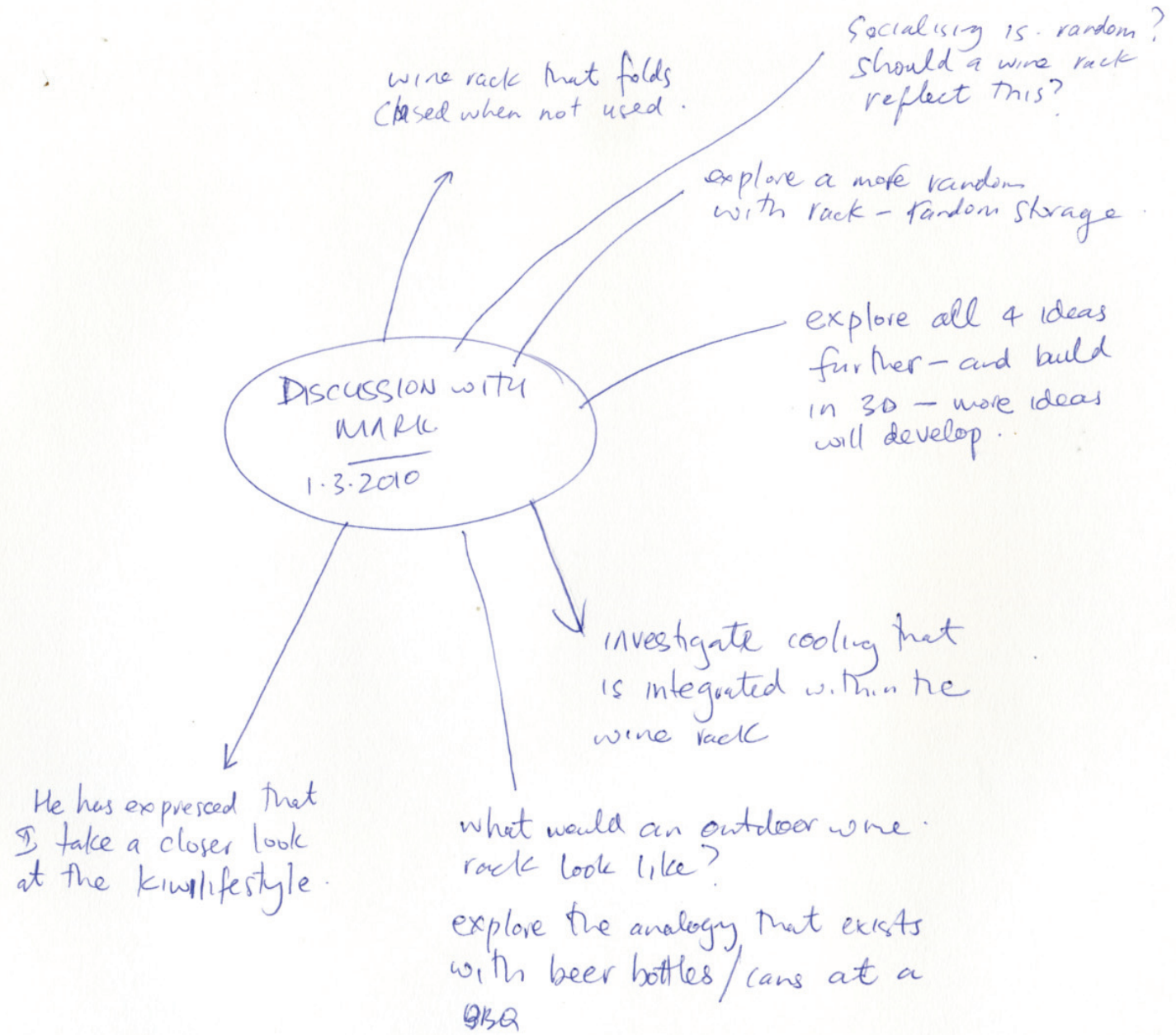

6 March 2010 © Jason Klenner

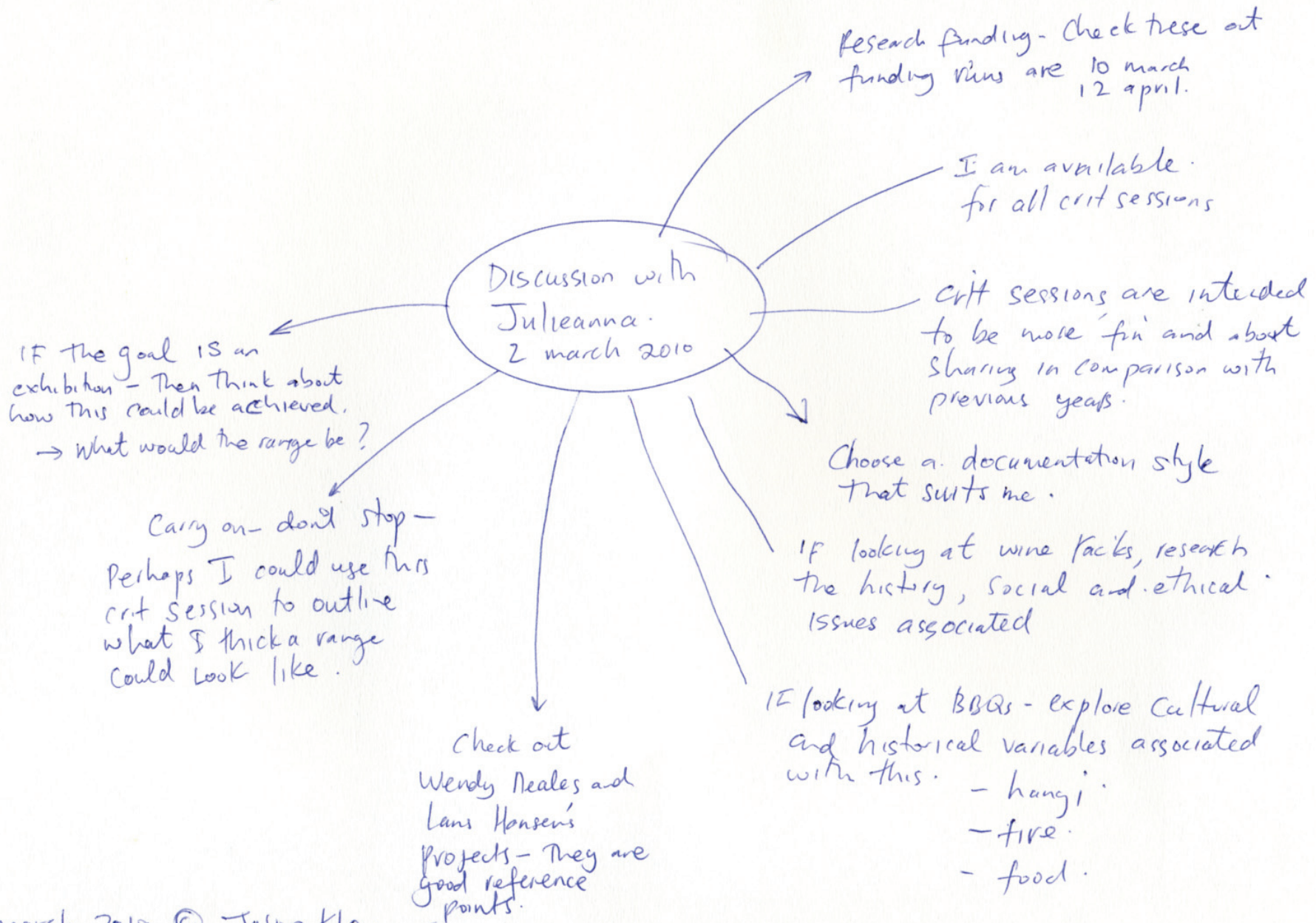

6 march 2010 © Jason Klenner

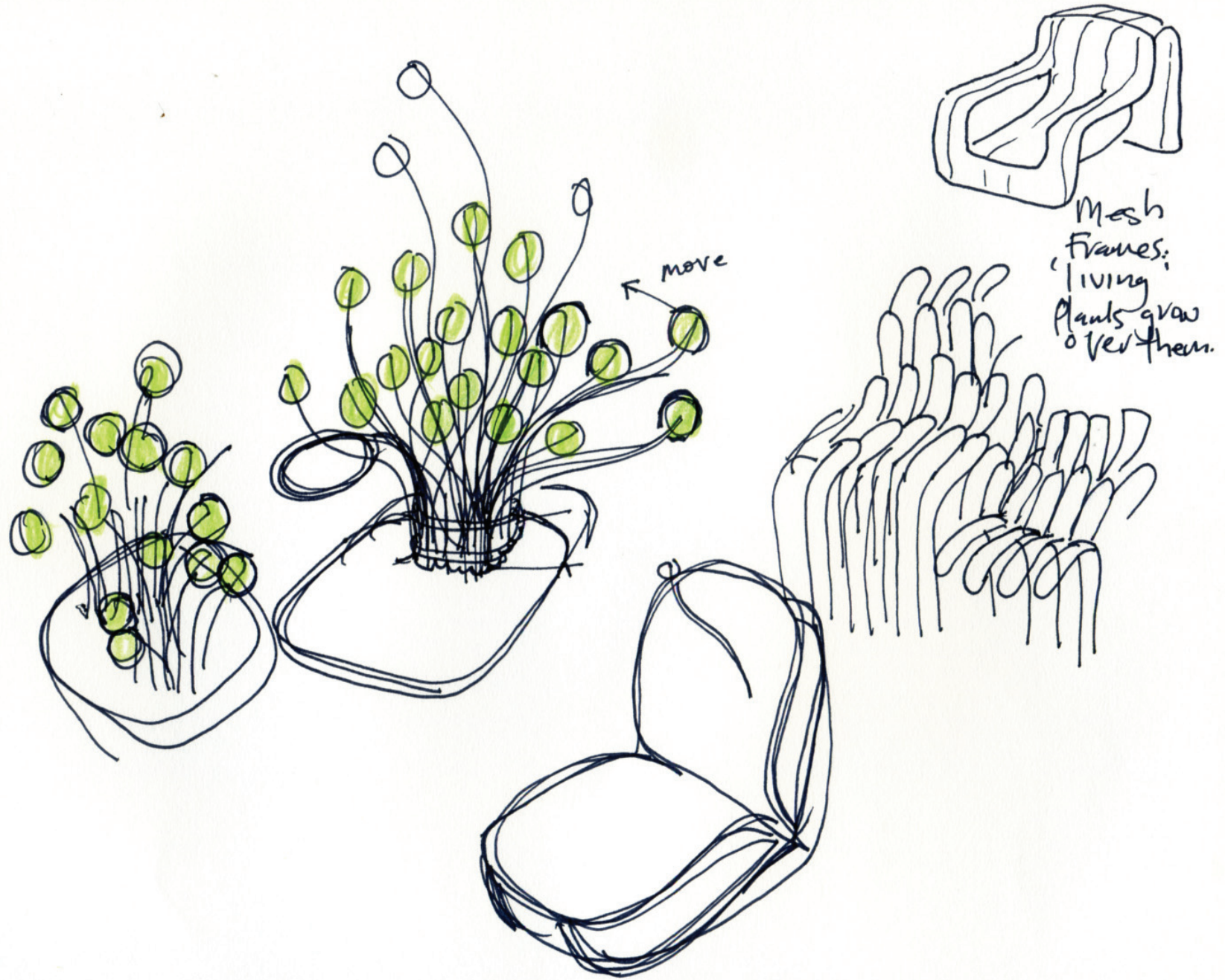

6 March 2010 © Jason Klenner

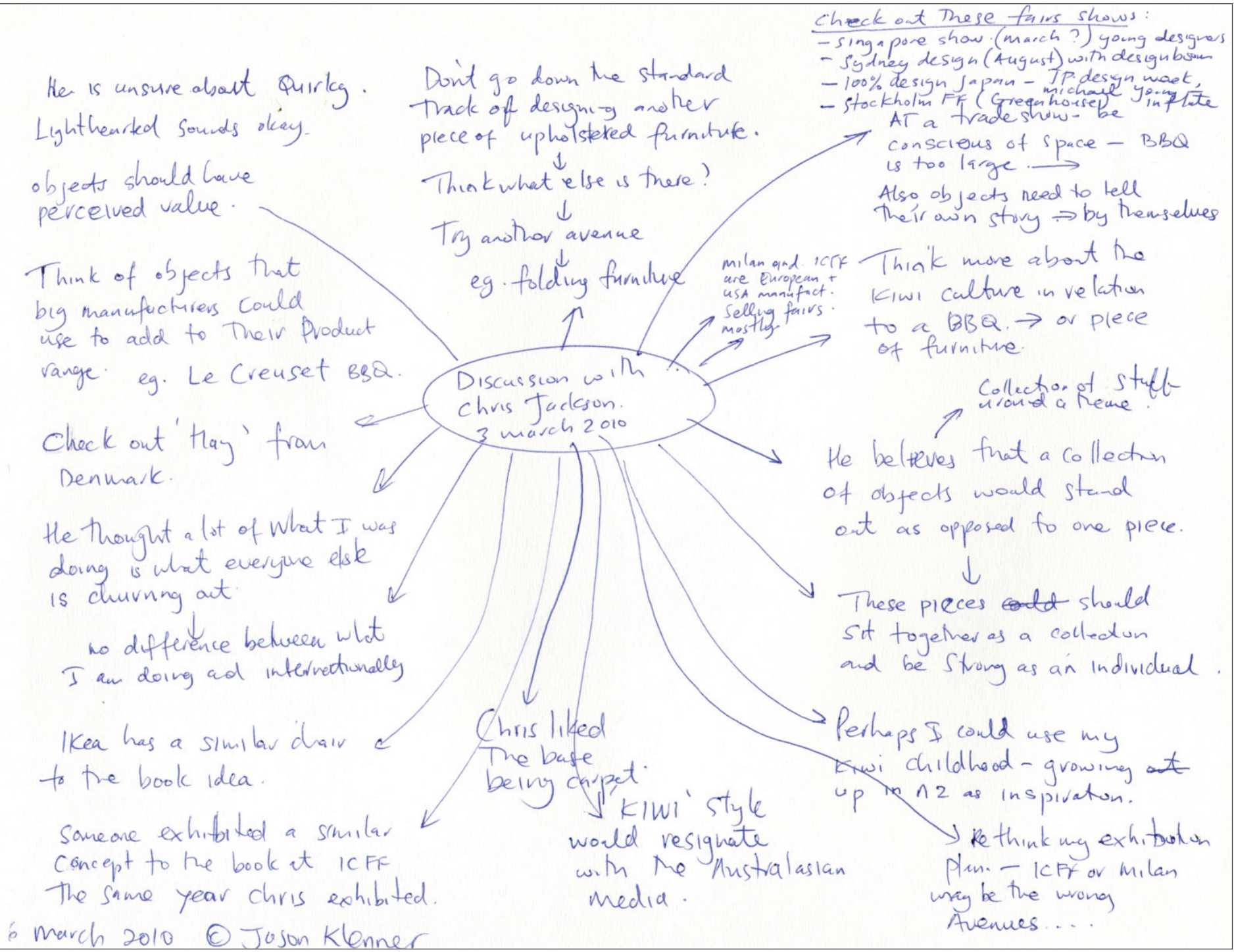

Direction Refining:

Research on:  
 → flowers increase  
 → Creativity  
 → flowers promote happiness.  
 → Casual mood.

Build up a series of images that express what I am trying to achieve.  
 ↓  
 What are these.?

IS THIS A GIVEN?

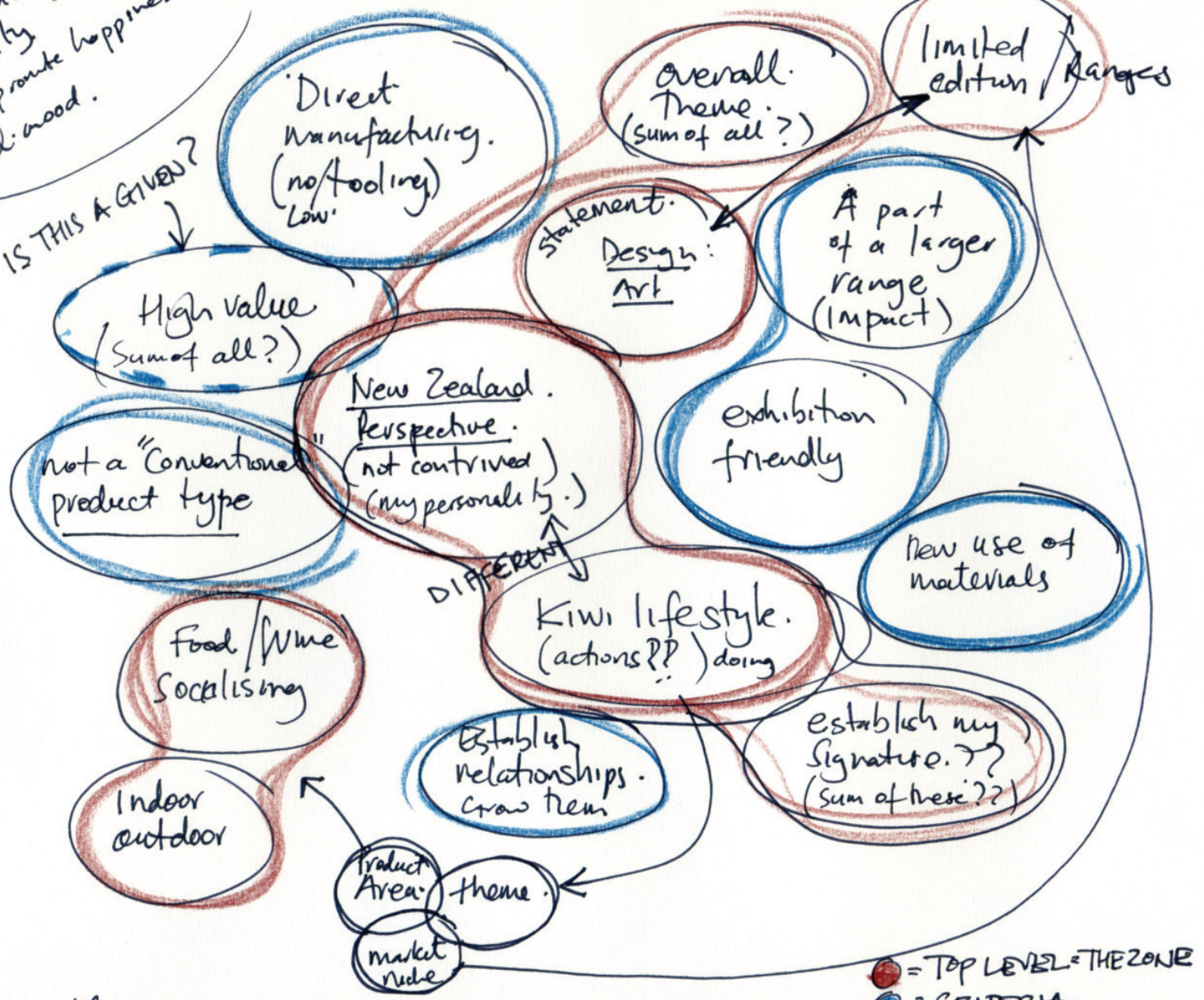

6 march 2010. © Jason Klenner

Direction Defining:

Food/wine/socialising.  
?. indoor/outdoor.

Associated  
Synonymous  
with a New  
Lifestyle.

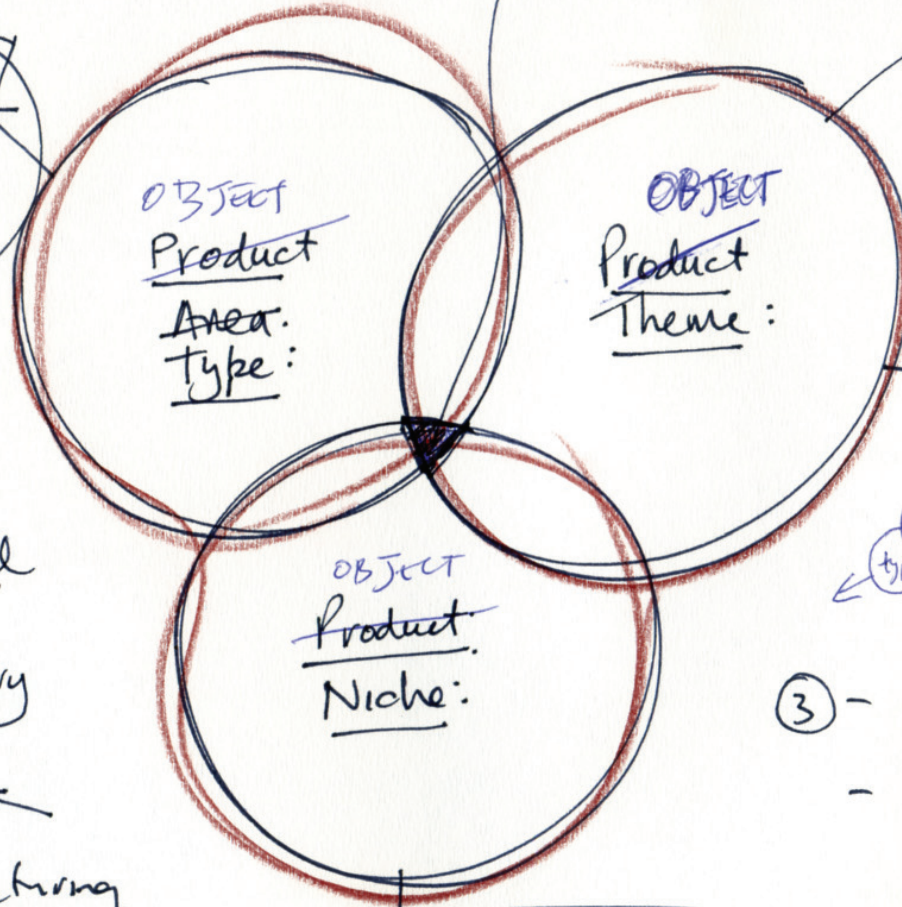

"Contextual field"

An expression of my  
view of the world  
as a New Zealander.

what is  
This.??

Associated/  
synon

light  
hearted!

Fun.?



①  
- Not a conventional  
product type/  
product category

③ - Apart of a larger  
range.  
- exhibition friendly.

②  
- Direct manufacturing.  
- New use of materials.

- Limited. edition. ↔ "Design Art"  
- High value.

Find out!  
Discover who  
I should target  
→ what manufacturer.

use images that express This!!!

Possible Product Families:

"The experience of wine" → Indoors + outdoors.

outdoor chair + outdoor table + outdoor lamp.

Wind break.

Storage outdoor:

- blanket → Hangi.
- Folding chair.
- table.
- Umbrella.
- lamp
- chilly bin.
- shade/shelter
- Lounger/couch.
- bbg
- bar /
- food storage.
- wine rack
- Pantry.

clock. Foot stool.

outdoor modular system



Pivot chair.

Herbs

Flower pots

THREADS COULD BE:

- EATING
- DRINKING
- COOKING
- TALKING
- READING
- PARTY.

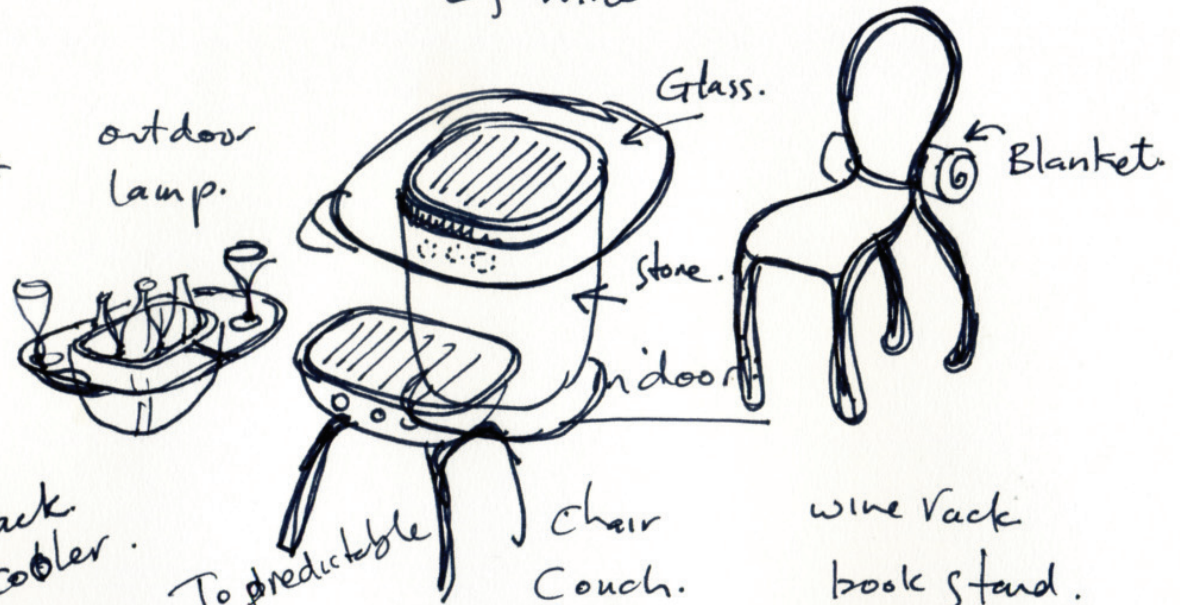

Outdoor fireplace.

side table.

Foot stool.

owner ship of seat.

- romance.

- SUMMERS NIGHT OUTDOOR



clusters.

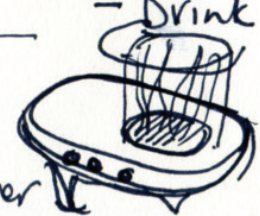

6 March 2010 © Jason Kleener

# Possible product families

Jandal Rubber

allowing cooling?

- Wine rack + wine cooler + table + chilly bin. + Jandals

- indoor chair + book + rug.?? + lamp.

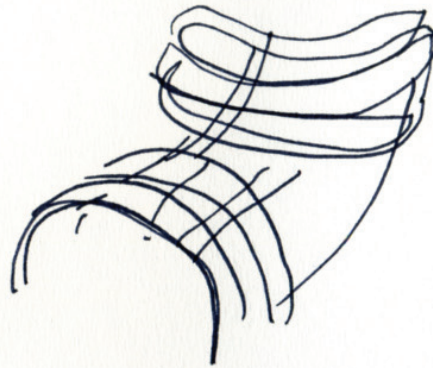
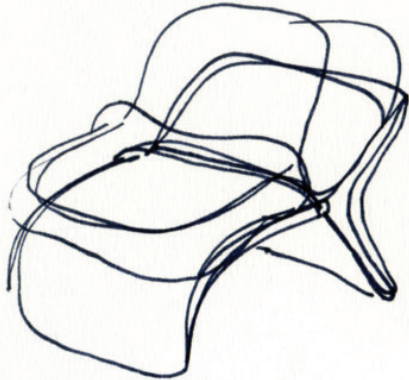

3 pieces



- outdoor chair + outdoor lighting + outdoor couch + outdoor table. or storage

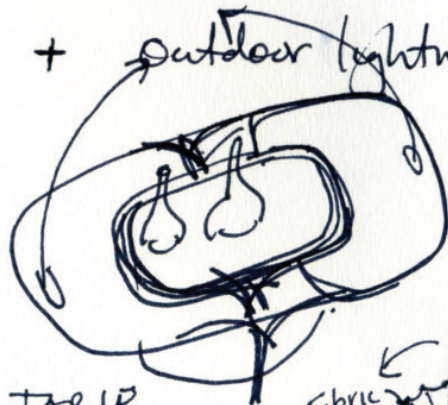
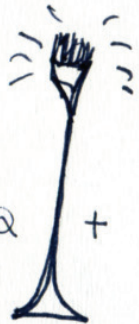

chilly bin table.

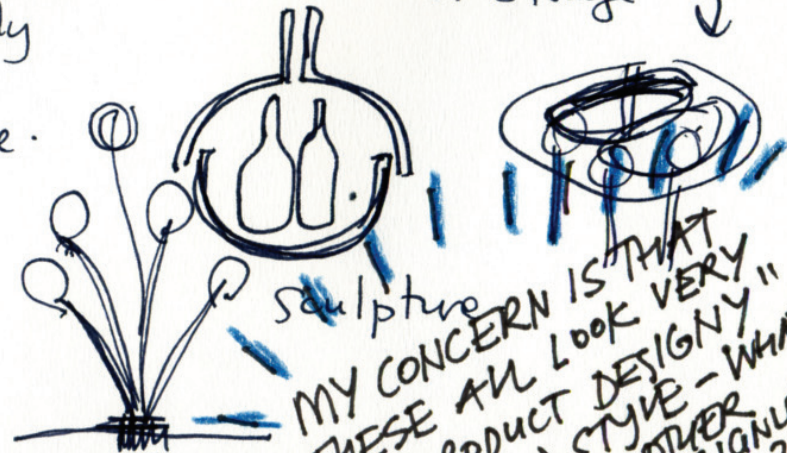
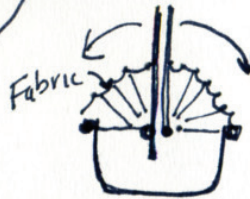

sculpture  
 MY CONCERN IS THAT  
 THESE ALL LOOK VERY  
 "PRODUCT DESIGNY"  
 IN STYLE - WHAT  
 DO OTHER  
 DESIGNERS  
 DO?

- BBQ + SIDE TABLE

6 March 2010 © Jason Klenner

# SNAPSHOT SESSION: What I need to prepare

1. INFO = Jason Klerner, etc.
2. Topic and Preliminary/emerging/refined questions or issues:

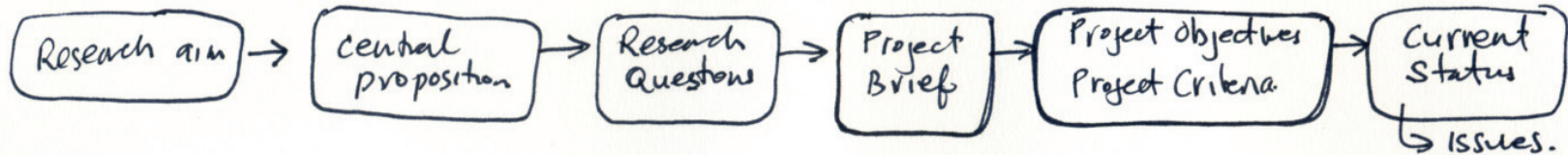

3. Context: An updated bibliography. creative works currently figuring as primary

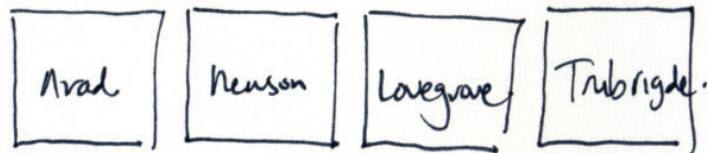

images of their work.

4. Diagram
5. Methods, processes and practice.

~~Res~~ Research for design  
Research Through design.

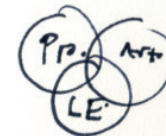

Lockheed.

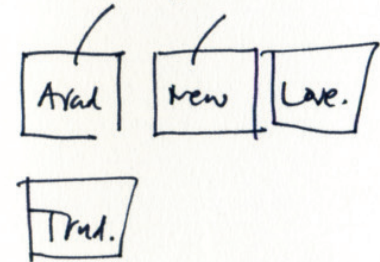

6. Visual map.



7 March 2010 © Jason Klerner

Possible model range / collection range:

Inspiration:

"indoor skins"

OR 4 Seasons of furniture.

- Mobile.
- light-weight.
- moveable.

Practical.

"indoor and outdoor. materials to express NZ more?"

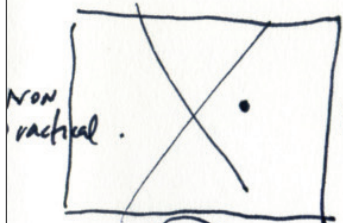
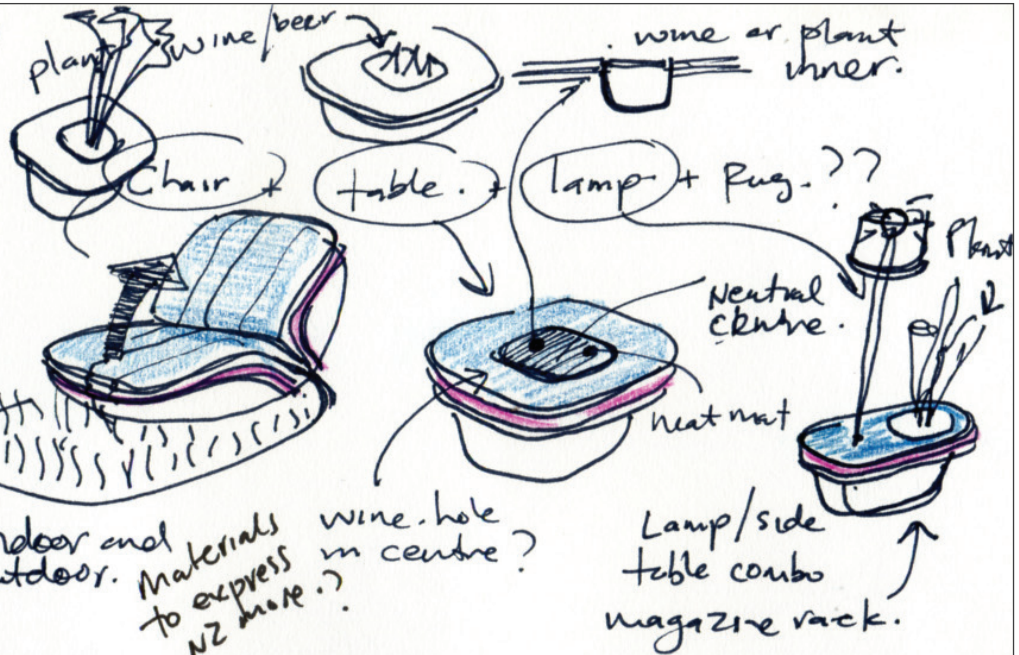

"experience of wine"

Wine racks. + chilly bin.

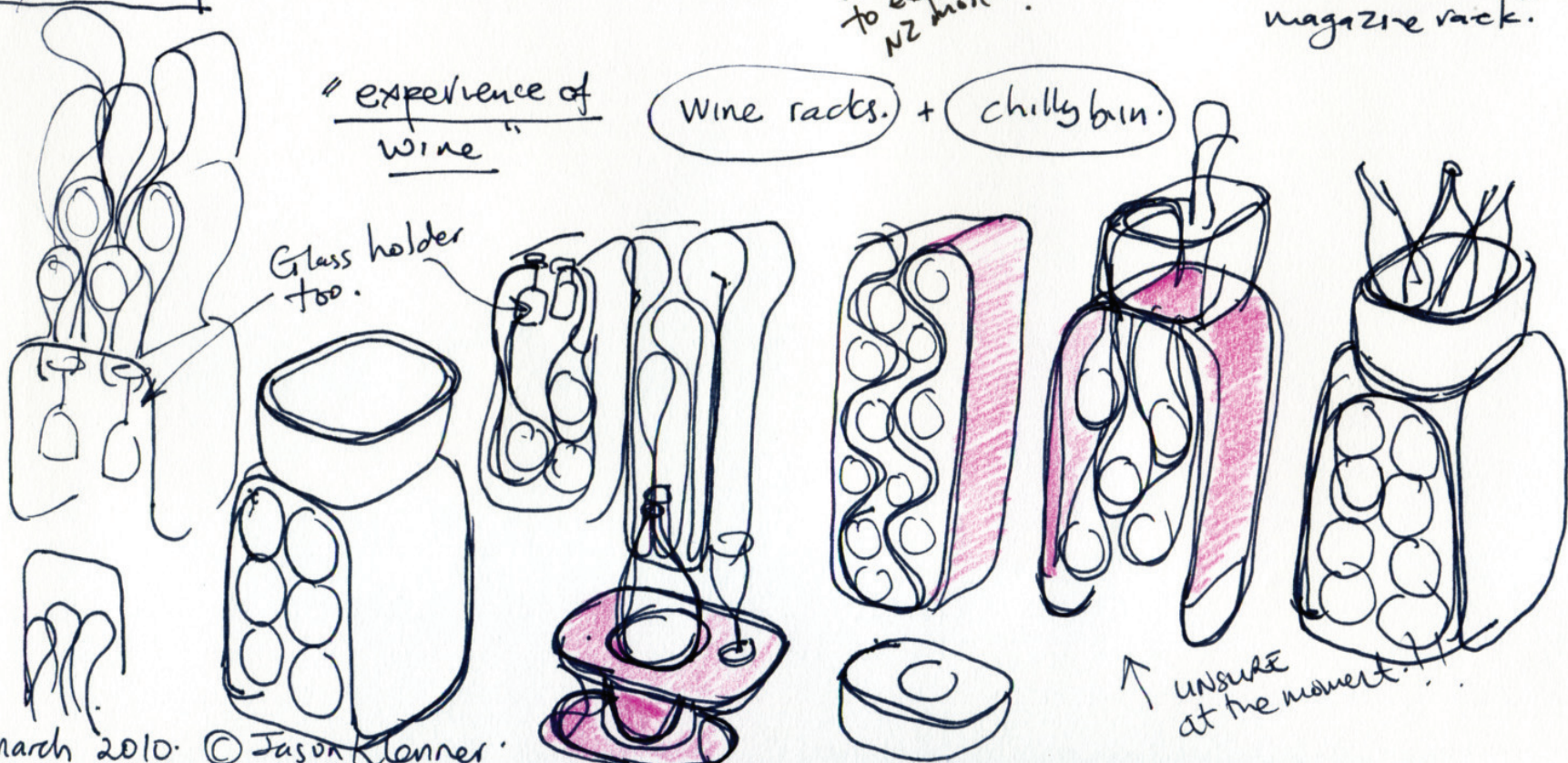

7 March 2010. © Jason Jenner.

Possible model range / collection range:

Inspiration. "The kwi BBQ" → BBQ. / chimney BIN / JANDALS / chair / stool  
 ↓ ↓ ↓ ↓  
 Setup and eat? Portable. wine / Table. Cool. / ledge..back. culture.

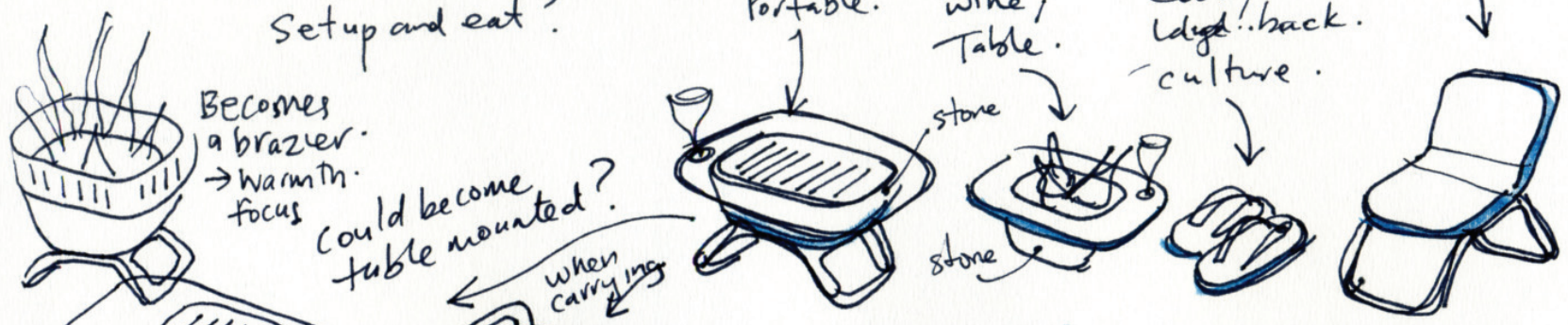

BECOMES a brazier. → warmth. focus

could become table mounted?

when carrying

Quality materials, laid-back, relaxed. simplifying. The new over-the-top outdoor experience.

Is there a market for this.? who are the potential manufacturers that may be of interest?

Too low rent?

"Outdoor Socialising"  
(not eating.)

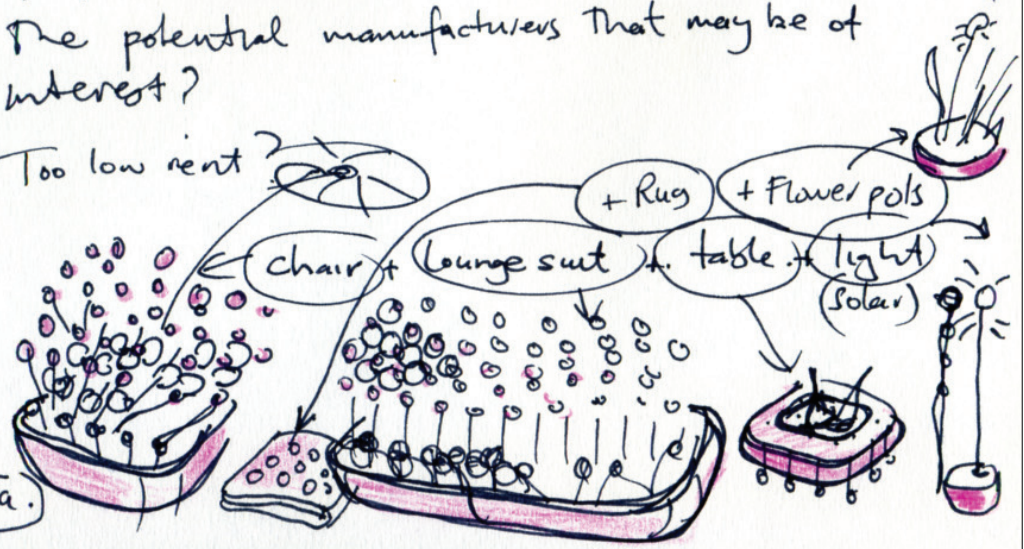
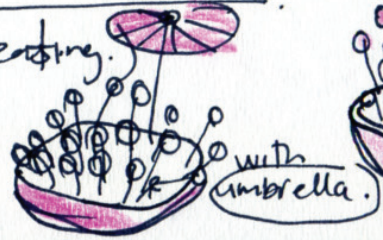

7 March 2010 @JasonKleener

Reference points: RON ARAD.

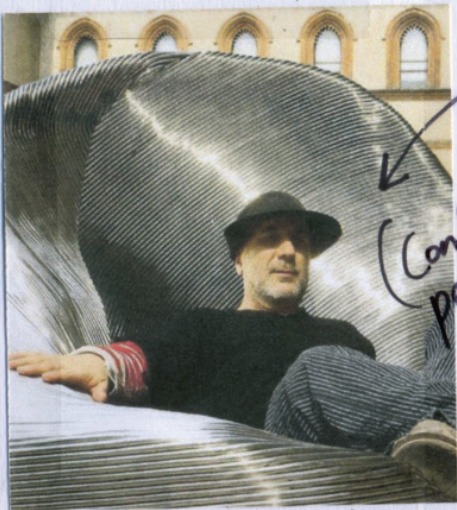

Artist Image

(Confirms his personality)



1986 Well Tempered chair.

1988 Big Easy Progression

1999 New Orleans chair

style is an art/sculptural inspired style?

High level concept Through various derivatives.

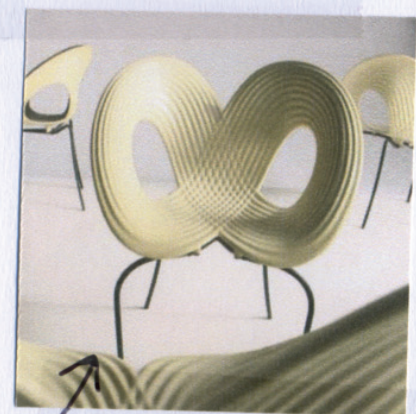
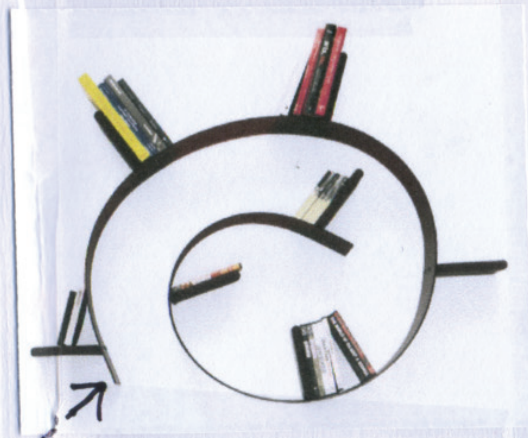

Concept transformed into a production item.

Art.

Production

Art + production?

Based on these images → Arad exists on the art side of Design Art. → more of a sculptural style.

7 March 2010 © Jason Klenner

Reference points : Ross Lovegrove.

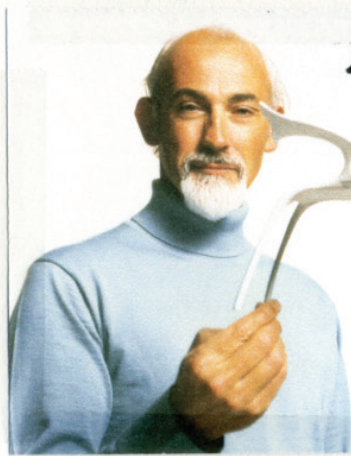

← (Calm, restrained and considered image. Lovegrove appears as though everything is under control. He is a thinker.)  
→ (Confirms his personality)

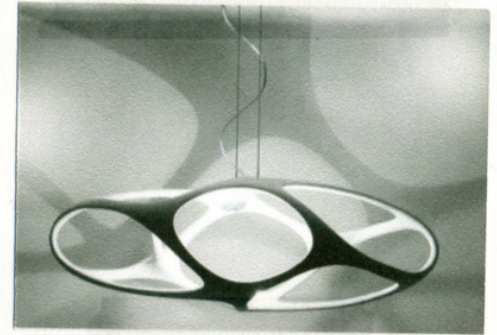
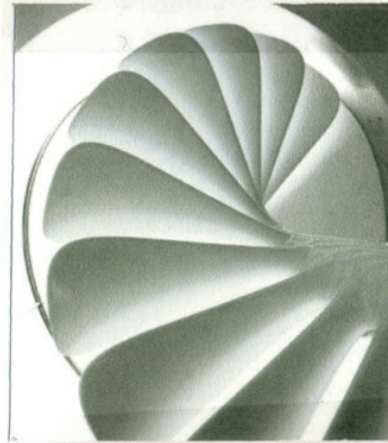

Pure/organic forms.

Style is Product  
Still a Product  
design style?

"Organic Essentialism"

Common Visual  
language.



Pure colours./  
materials.



20 million sold  
in one year.



Based on these images → Lovegrove exists on the design side of Design art. (organic style)

Random surface details (non-rational) © 7 March 2010 Jason Klenner

Reference points: Marc Newson.



'Cool  
guy'  
image.  
Cool designer  
(confirms his  
personality)



Embryo chair 1988



Initial piece: 1986.  
Lockheed Lounge  
Distinctive signature.  
1950s  
style forms.



Based on  
these images  
Newson exists  
on the  
1950s, retro  
design side  
of design  
art.



Strong  
graphic  
qualities  
Solid/  
new  
form.

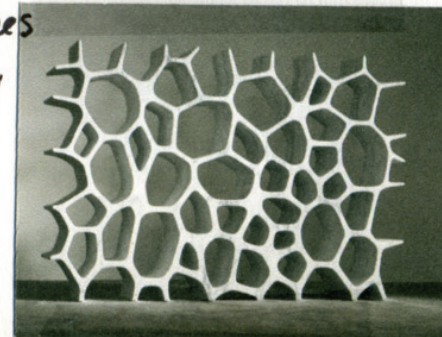

7 March 2010 © Jason Klawr Gallery Collection — Gagostian Gallery 2007 (Design Art/Highart)

Reference points: David Trubridge



maker/crafter image.  
(confirms his personality)



Based on these images, Trubridges signature is based around natural materials to create the illusion of being hand-made.

Natural material and handcrafted feeling.

repetition is an element through his work

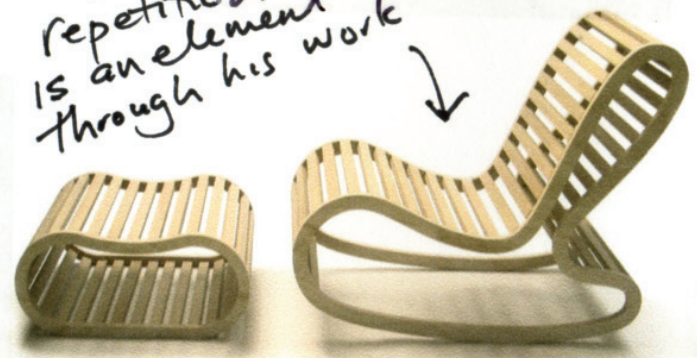
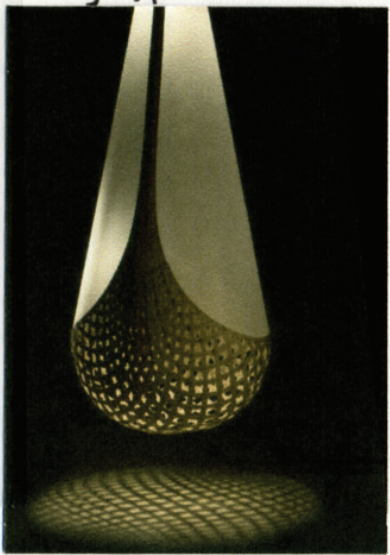

CNC router features heavily



These products look like they are an exception to David's signature (only through materials)

7 March 2010 © Jason Klenner

# Direction defining:

The creative process according to Trubridge:

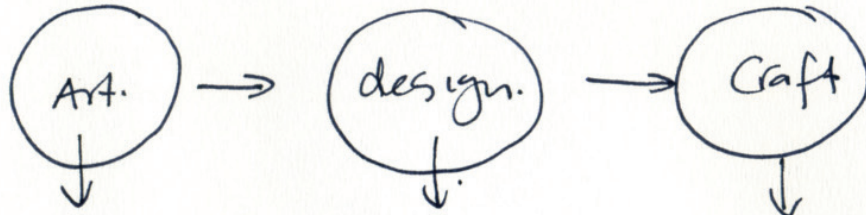

The development of your voice.

The articulation of your voice.

The making of the craft.

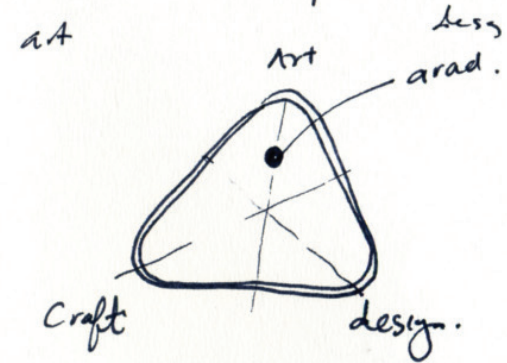
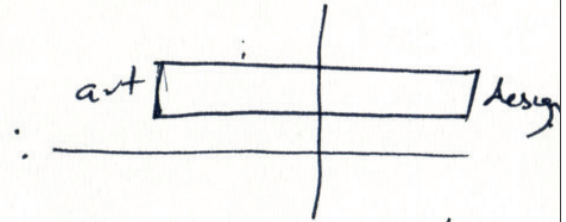

art → design



Lovegrove.

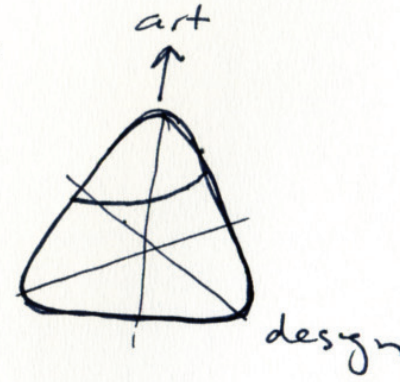

Craft

design



Newson.



Arad

Lovegrove.

Trubridge.

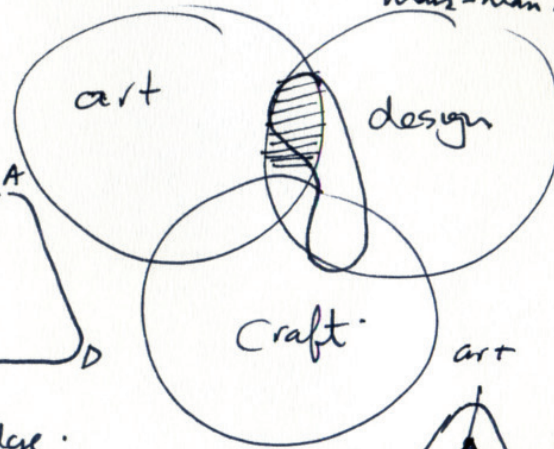

Craft.

art



design

art = creation of works of beauty  
design = work out the structure or form of something.

craft = occupation requiring skill with hands

A = art.  
C = craft  
D = design

7 March 2010 © Jason Klenner

Direction defining: Working Zones. art and design. or art vs design.

Design Art = Emotive more than rational.

emotional vs rational.

strong voice v neutral voice.

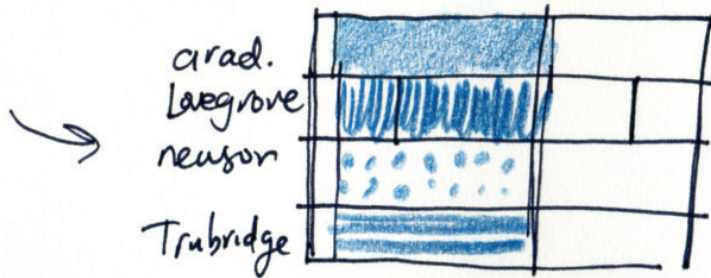

NOTE: These are the key elements behind. Their success - corporations and mass-market designers do not do this.

NOTE:

Arad, Lovegrove, Newson and Trubridge:

- > All have a strong voice.
- > All articulate this voice through their creative work.
- > All use materials and process to express their voice.

THIS TIES BACK TO TRUBRIDGES DESCRIPTION:

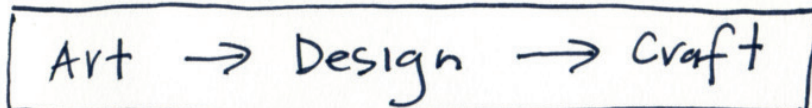

the creative process.      expressing.      Making

Art = creating the voice      Design = articulating the voice in an object      Craft = creating the object.

THEIR **STYLE** IS DIFFERENT, BUT THEIR APPROACH IS THE SAME → THEIR PROPORTION USED OF EACH ELEMENT ALSO VARIES.

← organic.  
- product style.  
- sculptural style  
- handmade style  
- 50s style.

↓ confirmed through their portraits.

Reference points



too conventional... but beautiful?

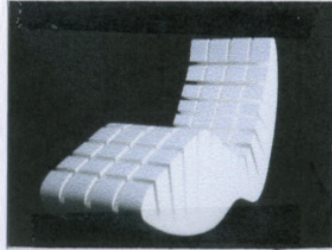

outdoor... - ?  
too rigid.



looks cheap?



Simple... but a wall flower? no statement statement

A chair in an exhibition?



Unrefined... no beauty

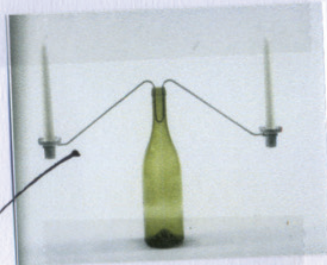

Simple/elegant



Left field: new approach

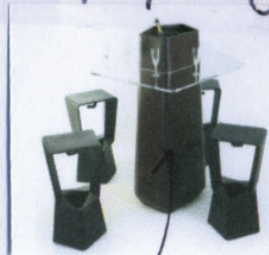

why? -



Label back



Beautiful.



personality



over the top - is this a Kiwi lifestyle?



potential range



Colour "personality"

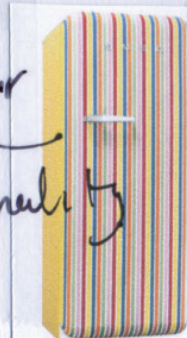

8 March 2010 @Jason Klemmer

Direction Defining

Rocking chair.

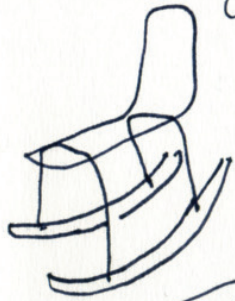

daybed



Indoor outdoor living

Outdoor tea set? N2 ceramics?

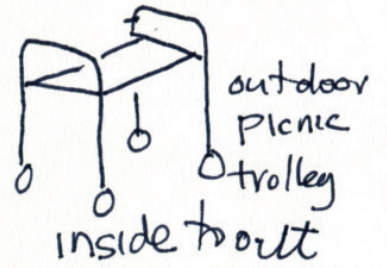

Outdoor living? Pots and pans for indoor/outdoor life.

New process of folding a chair.

Outdoor lantern



Safety flags around bly

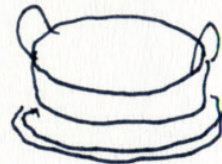

Also - Salt and pepper outdoors

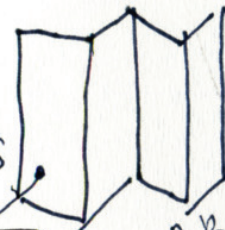

Screens

POSSIBLE OBJECTS

BBQ at the beach Project

BBQ in the Park Project

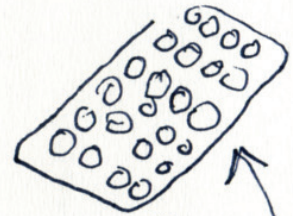

Dotty Rubber

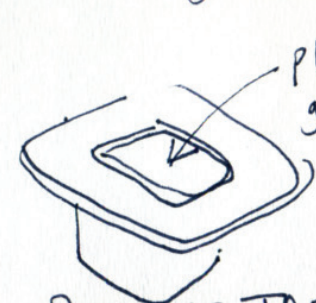

OUTDOOR TABLE

Plate/glass storage?



Plates!! in the garden

POSSIBLE THEMES

# THE ZONE: CONTEXTUAL FIELD



- HIGH VALUE
- LIMITED EDITION
- DESIGN ART.

- EXHIBITION FRIENDLY  
- A PART OF A LARGER RANGE.

- NEW/INTERESTING USE OF MATERIALS (DIRECT MANUFACTURING.)

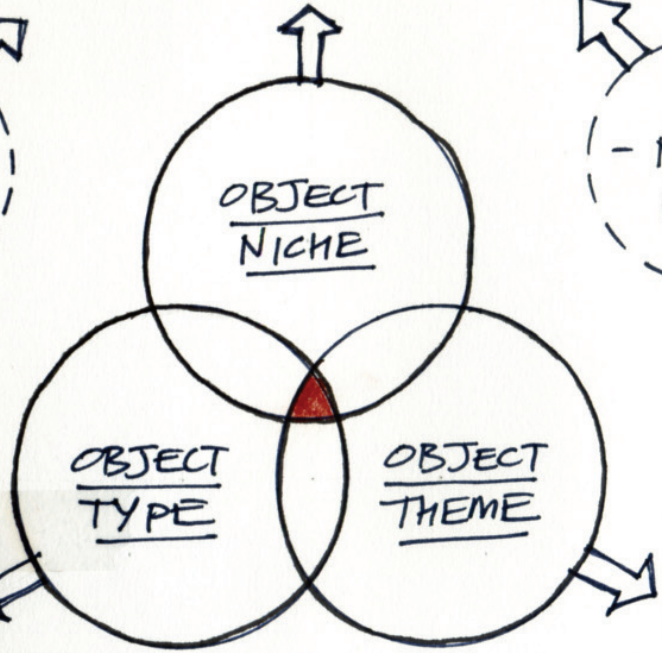

ASSOCIATED/SYNONYMOUS WITH A NEW ZEALAND LIFESTYLE.



FOOD/WINE/SOCIALISING OUTDOOR → INDOOR

- NOT A CONVENTIONAL PRODUCT TYPE / PRODUCT CATEGORY.

AN EXPRESSION OF MY VIEW OF THE WORLD AS A NEW ZEALANDER.

LIGHT-HEARTED/FUN / NOT TOO SERIOUS.



# FINDING AN ANGLE

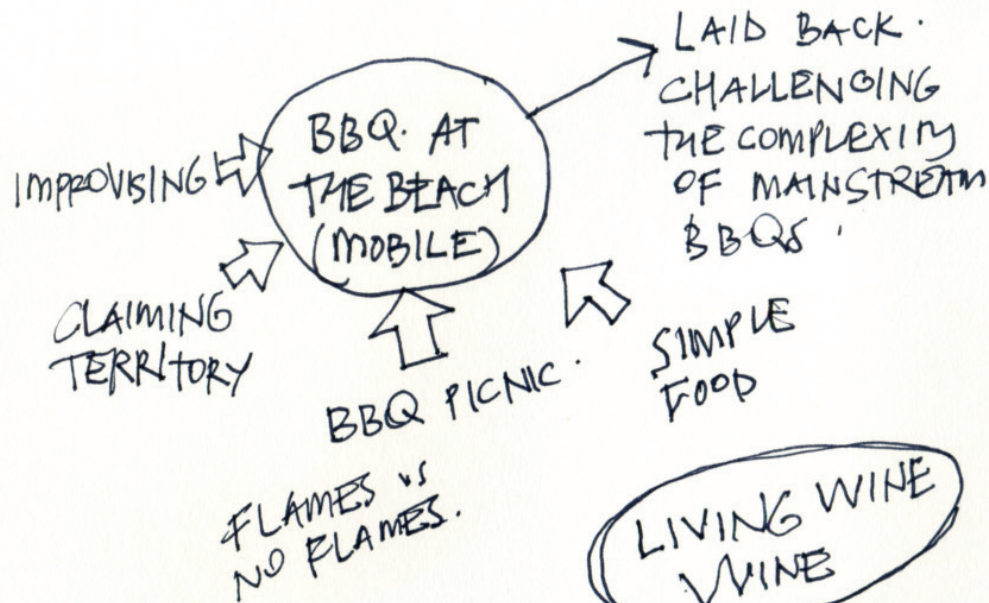

LIVING WINE  
WINE

Logic = keep the flame simple. as the bbq process is dirty. trolley will last for a long time.



SWIVEL / ROCKING CHAIR.

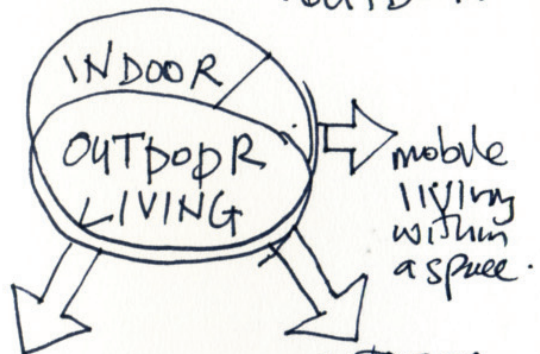
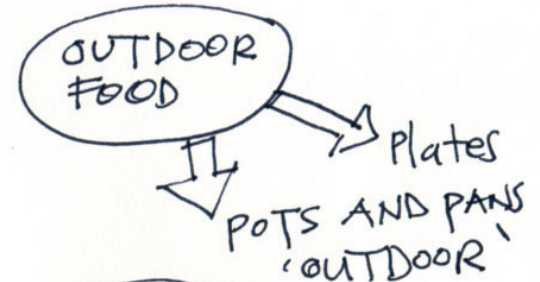

HYBRID FURNITURE / MULTI PURPOSE

OUTDOOR STORAGE CUPBOARDS

SEATING PROVISION TROLLEY



Wine Cooling

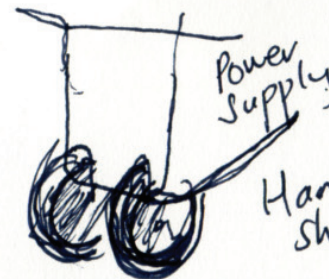

Power supply

Wine glasses

Handmade sheet steel.

9 March 2010 © Jason Klenner

Currently  
too  
Masculine

1. backup PC
2. Plan time
3. organize materials
4. email class
5. Print CRT Snapshot

ZSISICA

# CONCEPT FAMILIES.:

- > NOSTALGIC
- > LIGHT WEIGHT
- FOLDING



- > DELICATE
- > ROMANCE OF COOKING/FIRES
- > CASUAL
- > NEW RITUAL

mobile - picnic.  
 > chilli bin table. →  
 > Collapsible.



> Visual inspiration.  
 > which designer is it more closely aligned with?  
 > potential to get companies:?? materials.

→ high value  
 → Composite materials...  
 (Carbon)

> laid back social bbq.  
 (social cooking)  
 (Cooking system)  
 laid back  
 Jandal culture.

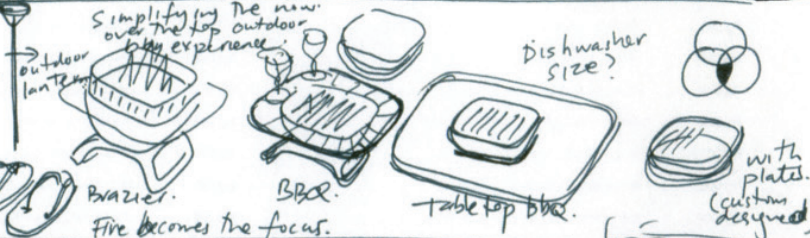

> Festive furniture.  
 > Sculptural.  
 > Planer like →  
 > uplifting fun forms.

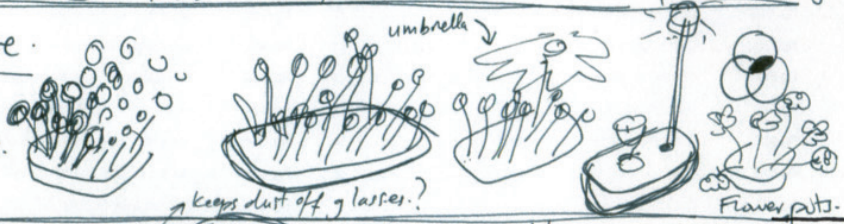

> The experience of wine.  
 > indoor/outdoor.  
 > Sculptural  
 > hot serious.  
 > Looks good full and empty.



- > FLOWING
- > STRUCTURAL.

- > OPTIMISTIC
- > NAIVE
- > RANDOM.
- > KINETIC.

13 March 2010 © Jason Klemmer

# CONCEPT FAMILIES



> Mobile Cupboards / Storage



NOT ENOUGH TIME TO DEVELOP!!

> Furniture Skives

4 season furniture.  
Bringing the outdoors indoors

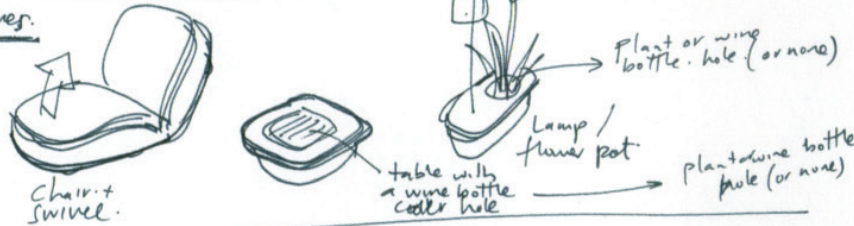

> FRESH  
> INDOOR ONLY??



FESTIVE:

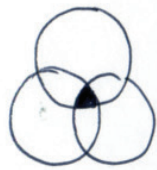

PAGES:

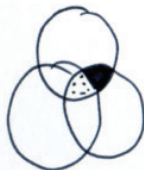

SHELVES:



BAR:



FOLDING:

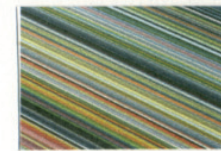
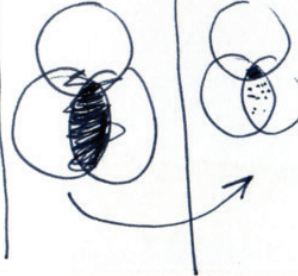

Needs more  
depth.

Needs more  
clearer  
direction.  
note of  
everything

Needs more  
niche  
depth  
→ Limited  
edition  
→ Craft/art  
element

Niche.

Type. theme

13 March 2010 © Jason Kerner

# UPHOLSTERY AUSORT: INDOOR FURNITURE RANGE

> CHOOSE/CHANGE THE UPHOLSTERY TO REFLECT YOUR MOOD.

> A SEASON UPHOLSTERY?

> SELECT THE UPHOLSTERY TO SUIT YOUR GUEST (COMFORTABLE VS UNCOMFORTABLE)

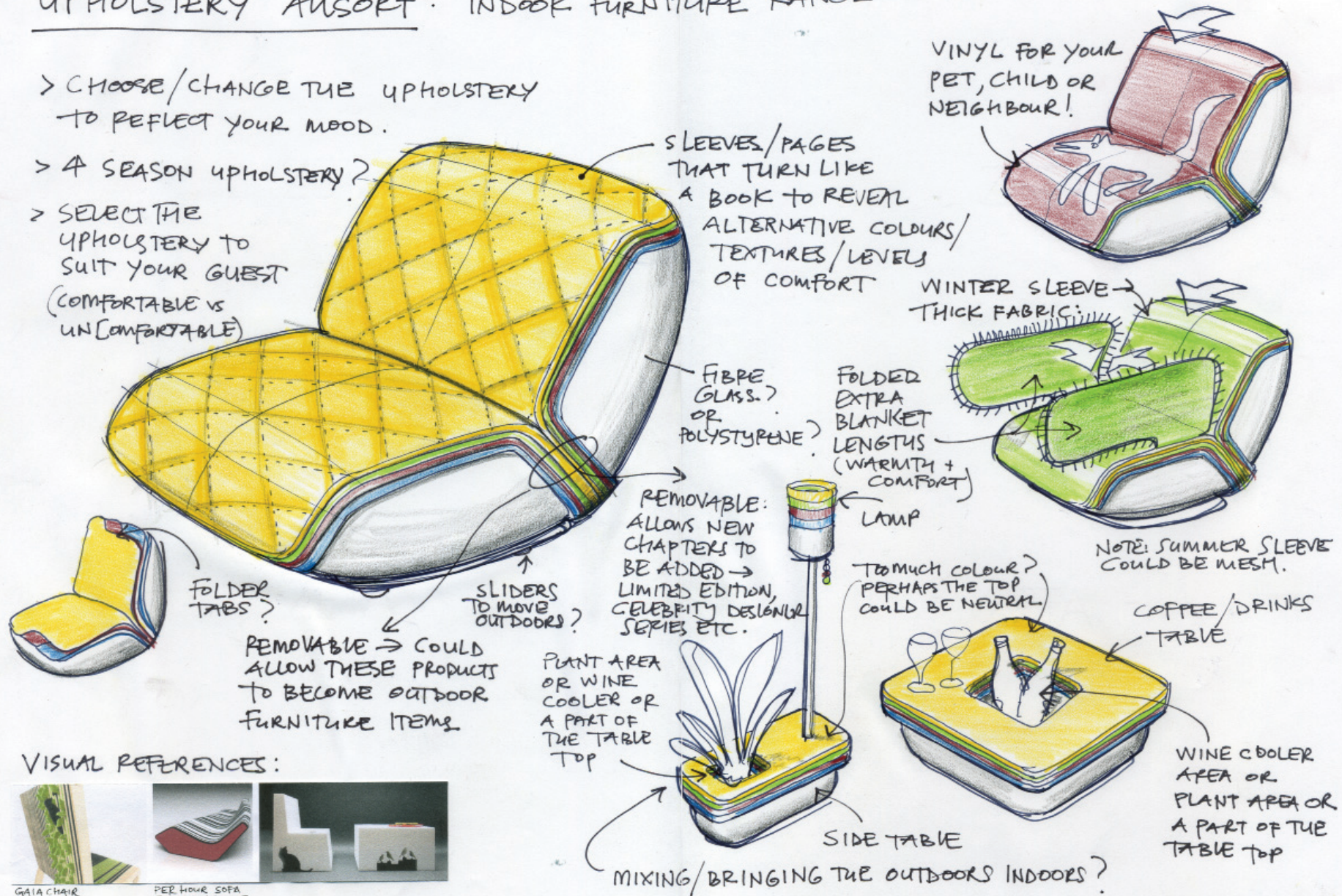

## VISUAL REFERENCES:

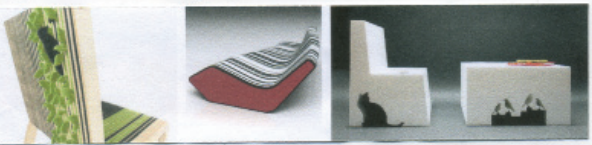

GATA CHAIR TUJO DESIGN  
PER HOUR SOFA FABIO NOVEMBRE

© Jason Klenner 14.03.2010

# FESTIVE OUTDOOR FURNITURE: OUTDOOR FURNITURE RANGE

- > SCULPTURAL
- > FLOWER LIKE/UP-LIFTING.

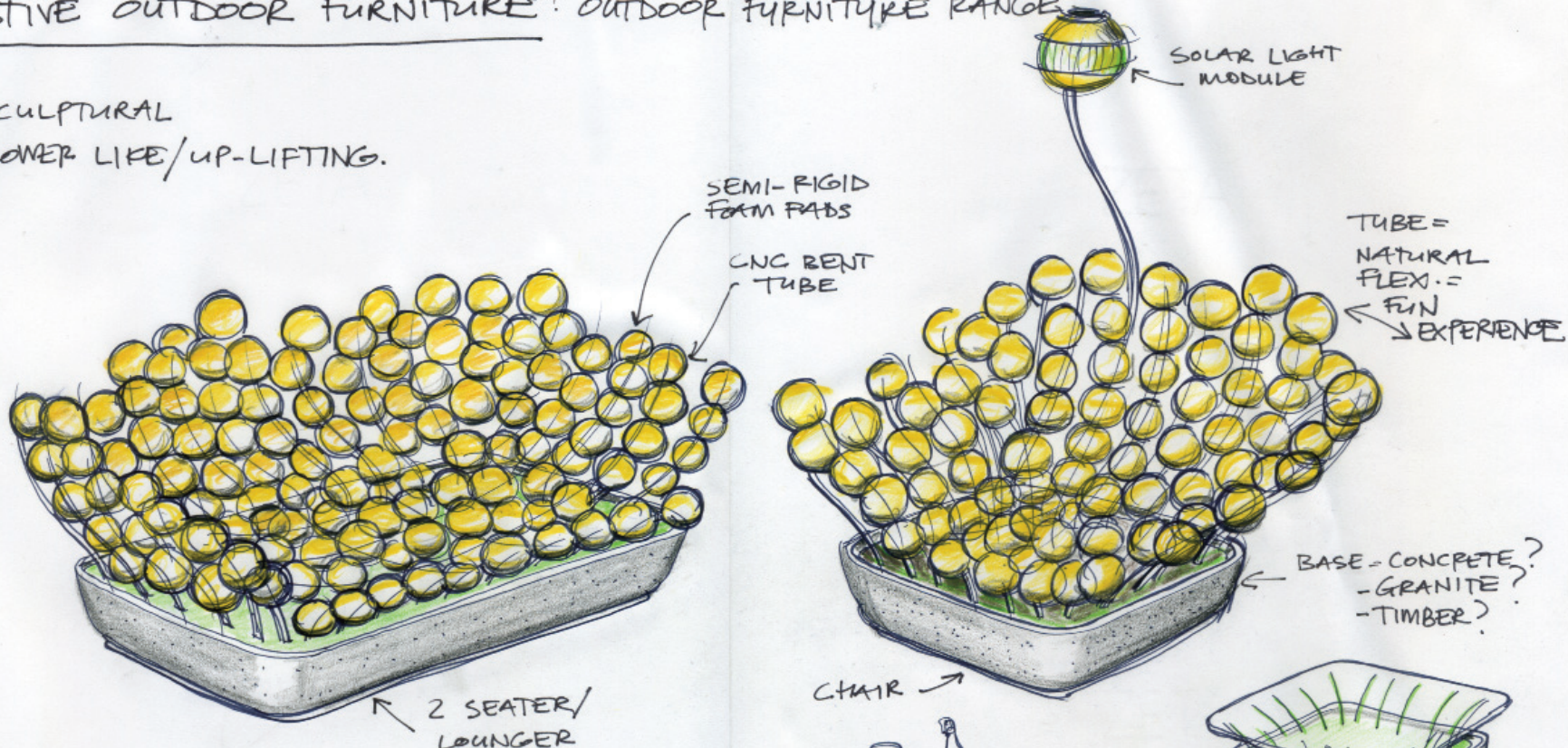

## VISUAL REFERENCES:



BLOW-UP: A BAMBOO COLLECTION  
CAMPANA BROTHERS



ZSISKA  
LUCITE  
CUBE  
NECKLACE

LODA EASY CHAIR  
KENNETH COBONPUE

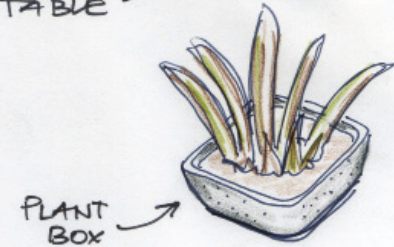
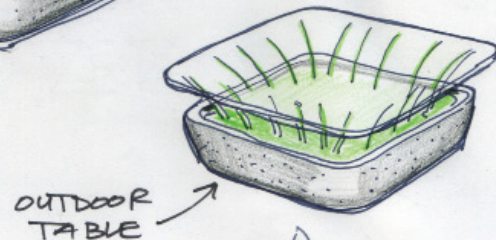
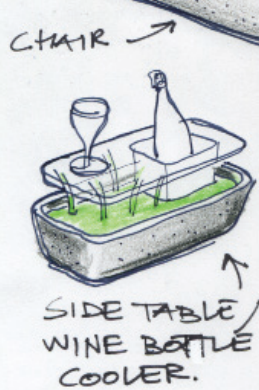
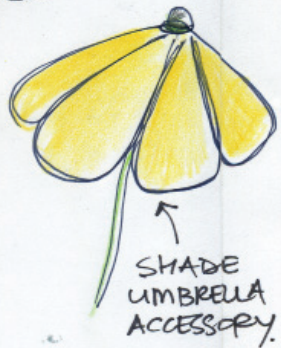

© Jason Klenner 14.03.2010

# WINE STORAGE : A FAMILY OF PRODUCTS. (MODULAR)

- > SCULPTURAL
- > NOT SERIOUS
- > LOOKS GOOD FULL AND EMPTY
- > EXPLORES THE EXPERIENCE ASSOCIATED WITH WINE DRINKING

## VISUAL REFERENCES:



JAMES IRVINE DADOI CLOTHES STAND

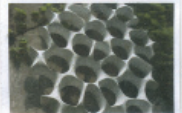

ELEGANT EMBELLISHMENT



SIGNATURE SHELF METACONCRETE



FRANK GEHRY TORQUE RING

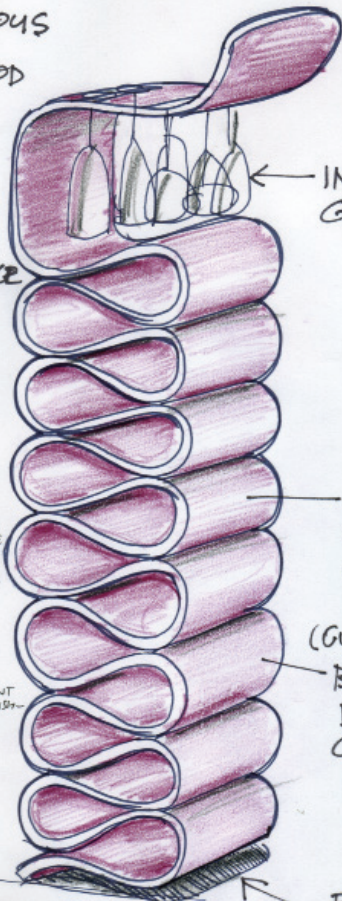

INTEGRATED GLASS STORAGE

SHEET METAL CNC FORMED/BENT (CURRENTLY TOO REGULAR SHAPE)  
BRIGHT COLOUR. DIFFERENT COLOUR INSIDE?

FLOOR MOUNTED. (BUT IT COULD BE HUNG AND HAVE A SPRING LIKE EFFECT - KINETIC)

NOTE: WINE COOLING NEEDS TO BE INCORPORATED → ALONG WITH AN UNDERSTANDING OF HOW THE WINE STORAGE INTERACTS WITH THE WINE DRINKING/WHOLE EXPERIENCE

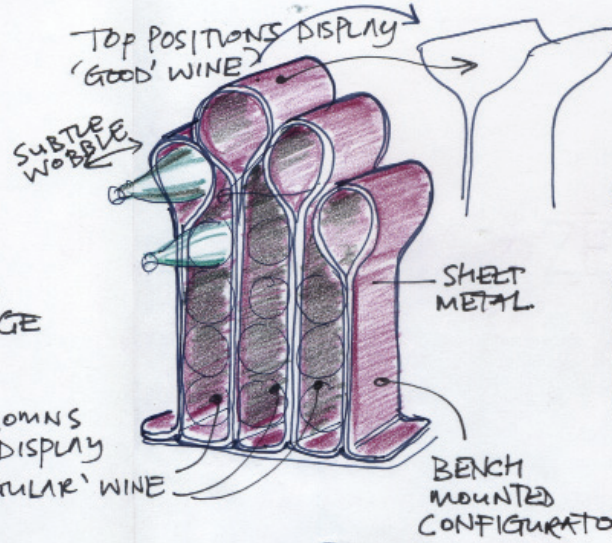

TOP POSITIONS DISPLAY 'GOOD' WINE

SUBTLE WOBBLE

SHEET METAL

COLUMNS TO DISPLAY 'REGULAR' WINE

BENCH MOUNTED CONFIGURATION

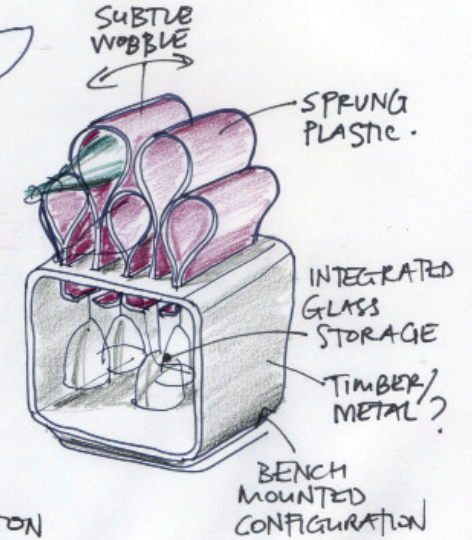

SUBTLE WOBBLE

SPRUNG PLASTIC

INTEGRATED GLASS STORAGE

TIMBER/METAL?

BENCH MOUNTED CONFIGURATION

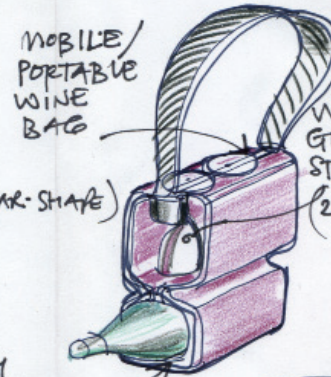

MOBILE/PORTABLE WINE BAG

WITH INSULATED WRAP

WINE GLASS STORAGE (2x GLASSES)

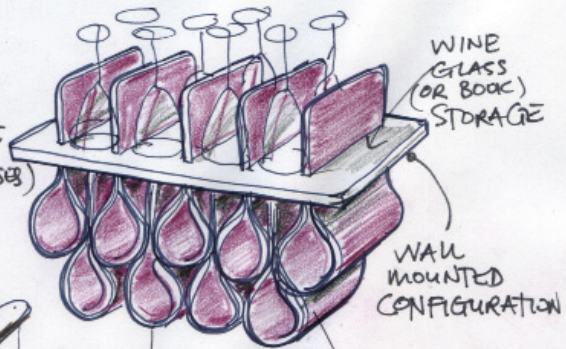

WINE GLASS (OR BOOK) STORAGE

WALL MOUNTED CONFIGURATION

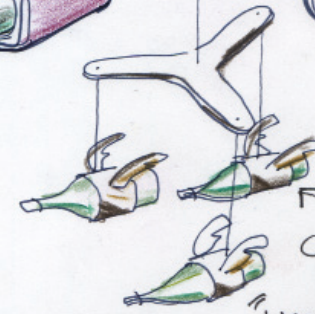

SPRUNG PLASTIC (OR STEEL)

CEILING MOUNTED MOBILE

"HANGING DUCKS"

©Jason Klenner 14.03.2010

# TABLE TOP / PICNIC BBQ : FOR COOKING QUALITY, NOT QUANTITY

> EAT WHILE YOU COOK.

> DELICATE / LAID BACK STYLE IS INTENDED TO CONTRAST THE OVER-THE-TOP / MASCULINE AESTHETIC FEATURED IN CURRENT BBQ DESIGN.

> INDOOR AND OUTDOOR FRIENDLY.

> SIMPLIFYING THE NOW COMPLICATED NEW ZEALAND BBQ EXPERIENCE

CANDLE TO SYMBOLIZE FIRE, COOKING + ROMANCE

COOKING PIT = STONE / SOLID (REMOVABLE FROM BASE)

DRINK / STORAGE SPACE FOR PICNIC SITUATIONS

BASE: MATT FINISH WITH DELICATE PATTERN.

HEAT / COOKING METHOD TBC. GAS, BUTANE OR FLAME.

CARRY HANDLES

BRAZIER COMPONENT FOR POST BBQ CONVERSATIONS

ACCESSORIES

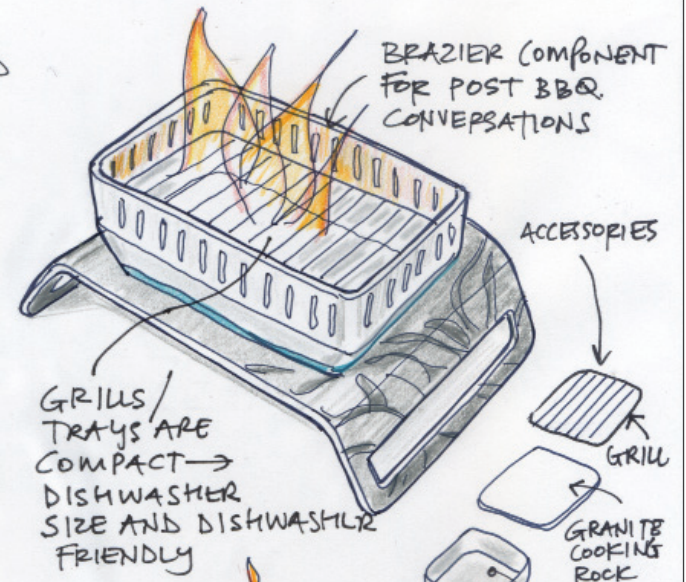

GRILLS / TRAYS ARE COMPACT → DISHWASHER SIZE AND DISHWASHER FRIENDLY

TABLE TOP CONFIGURATION.

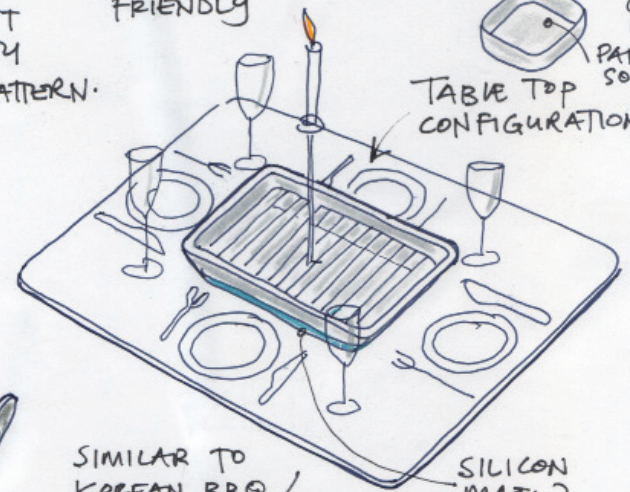

SILICON MAT. ?  
SIMILAR TO KOREAN BBQ / GALBI → PARTICIPATION FOOD → EAT SLOWLY AND SOCIALISE

BASE FLIPS TO CREATE CARRY HANDLES WHEN TRANSPORTING TO A VENUE

MATCHING JANDALS



VISUAL REFERENCES:

ANTITHESIS:



MONARCHY ROCKING STOOL YIANNIS GHIKAS  
CANDLOOP SEBASTIAN BERGME  
ELECTROLUX NEW ISLAND BBQ

© Jason Klenner 15.03.2016

# THE ZONE : CONTEXTUAL FIELD



THE AREA OF CRAFT AND DESIGN  
(HIGH-VALUE, LIMITED-EDITION, DESIGN ART)



> EXHIBITION FRIENDLY  
> A PART OF A LARGER PRODUCT RANGE

NEW/INTERESTING USE OF MATERIALS (DIRECT MANUFACTURING)



ASSOCIATED/SYNONYMOUS WITH A NEW ZEALAND LIFESTYLE  
(FOOD / WINE / SOCIALISING)  
OUTDOOR → INDOOR

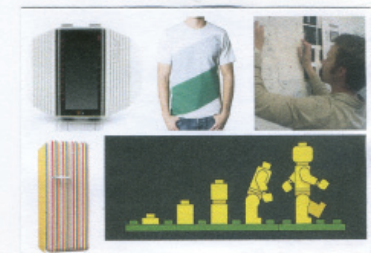

AN EXPRESSION OF MY VIEW OF THE WORLD AS A NEW ZEALANDER  
(LIGHT HEARTED / FUN / NOT TOO SERIOUS)

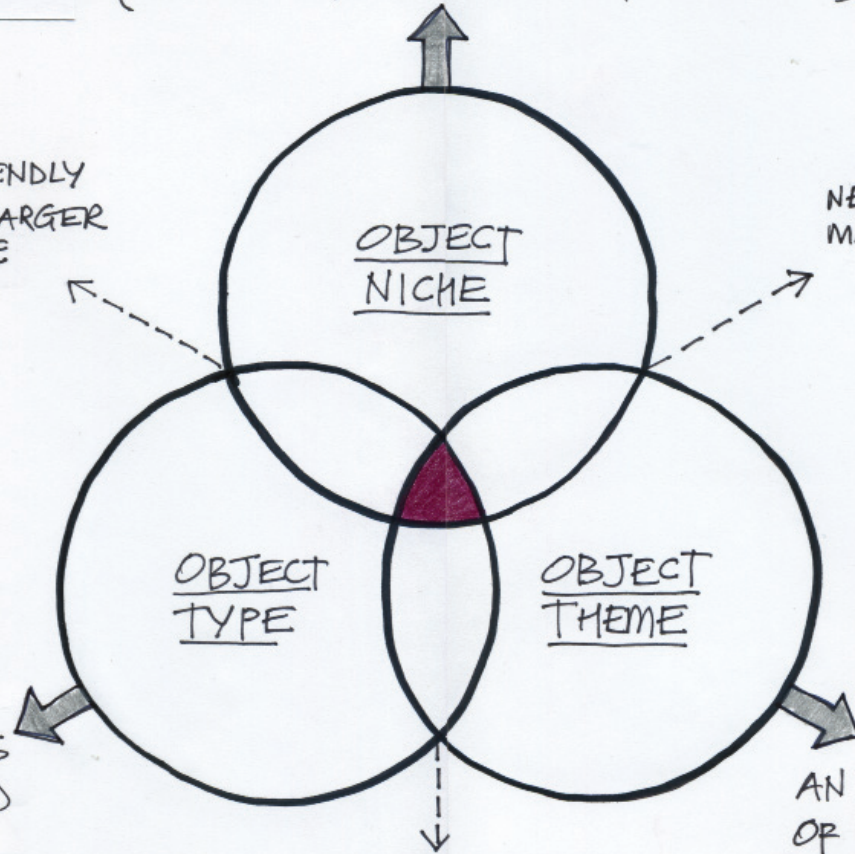

NOT A CONVENTIONAL PRODUCT TYPE/CATEGORY

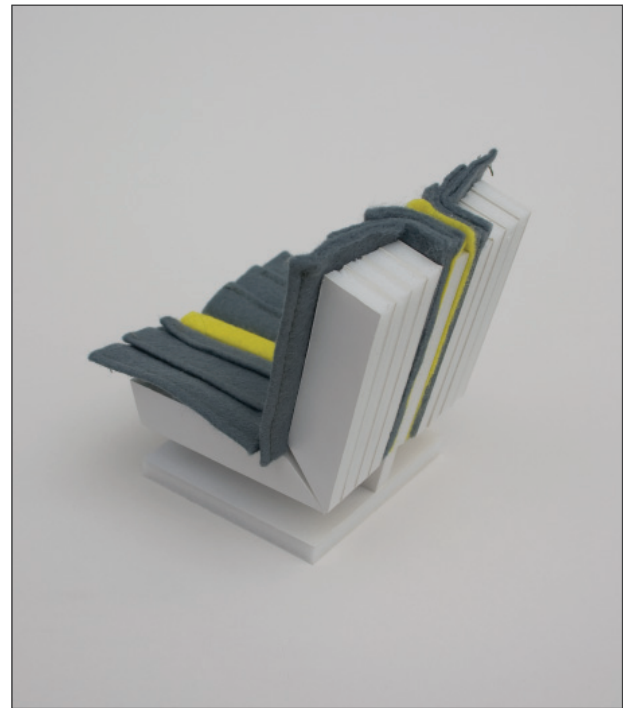
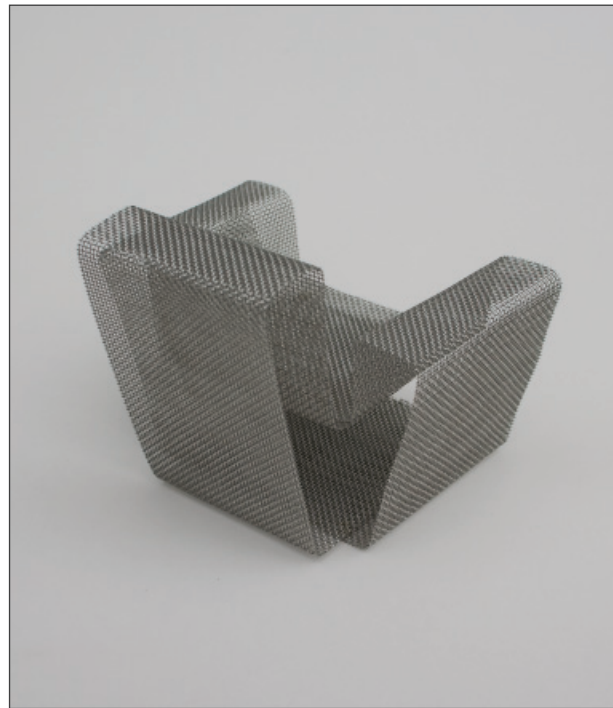
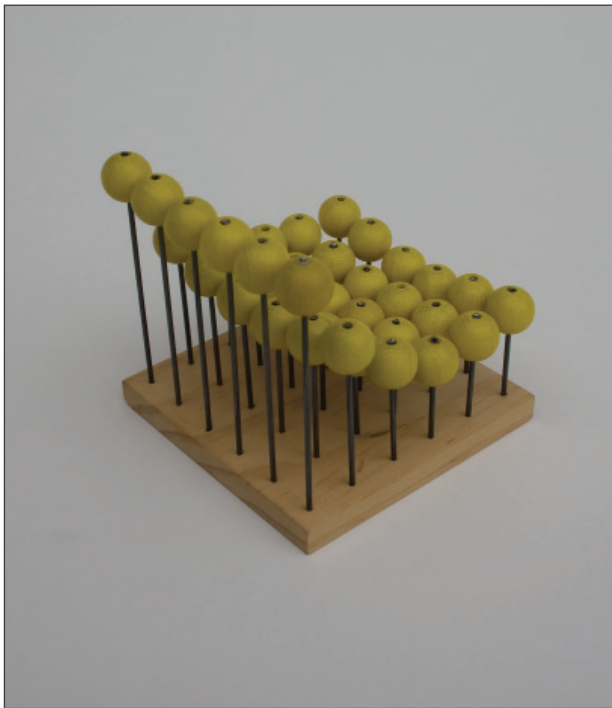
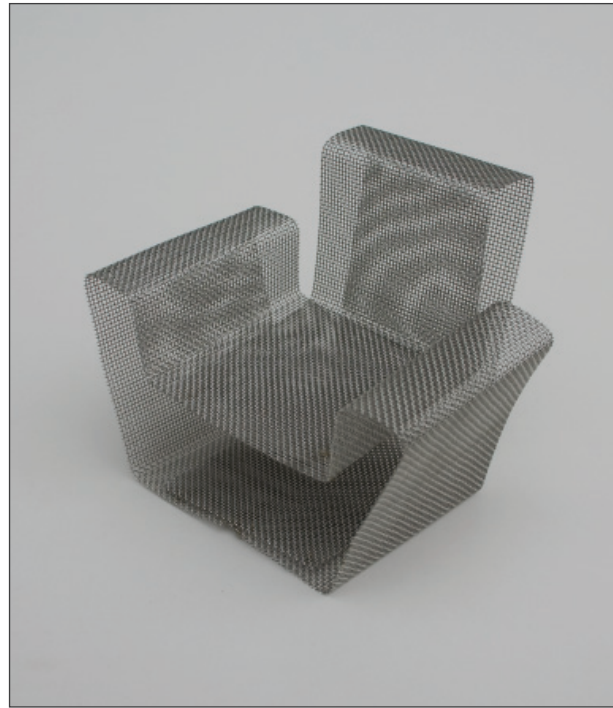
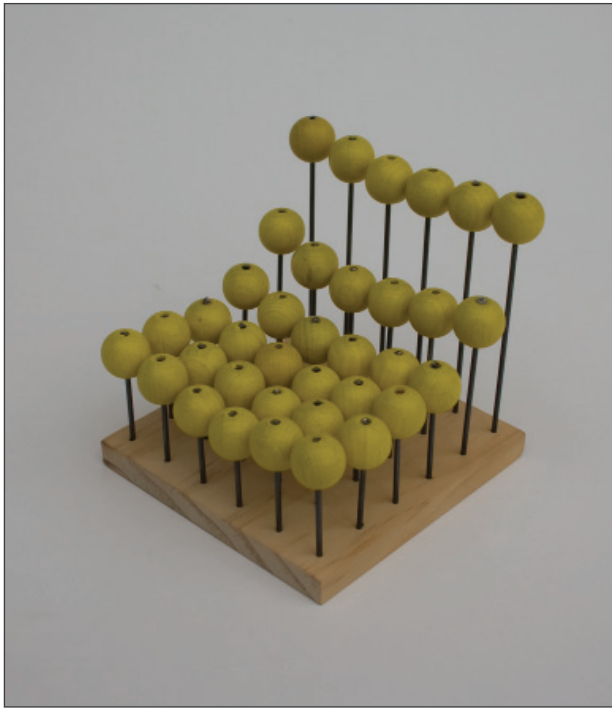

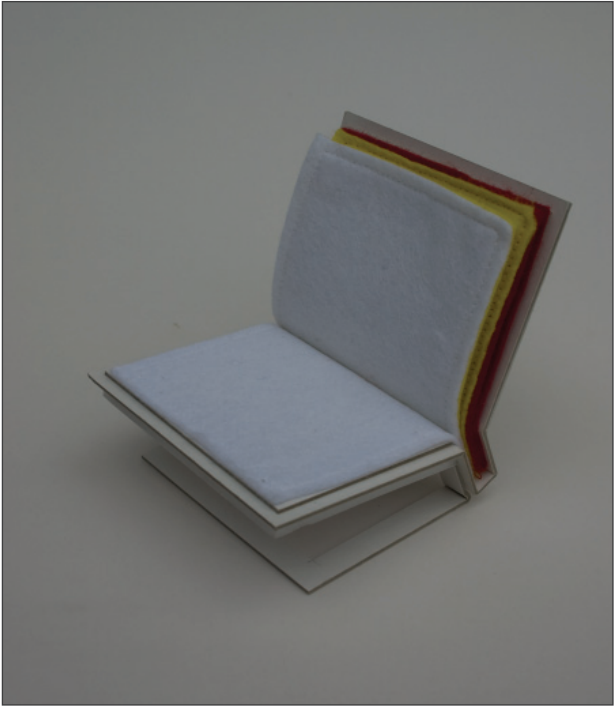
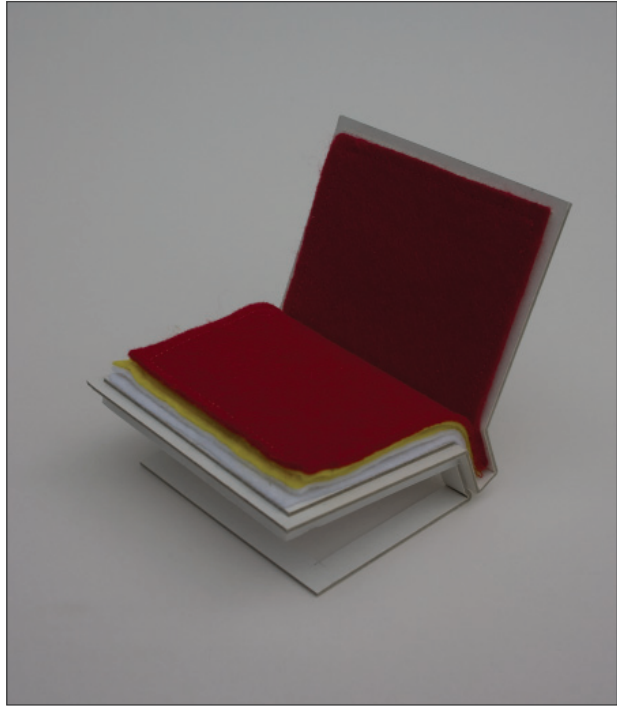

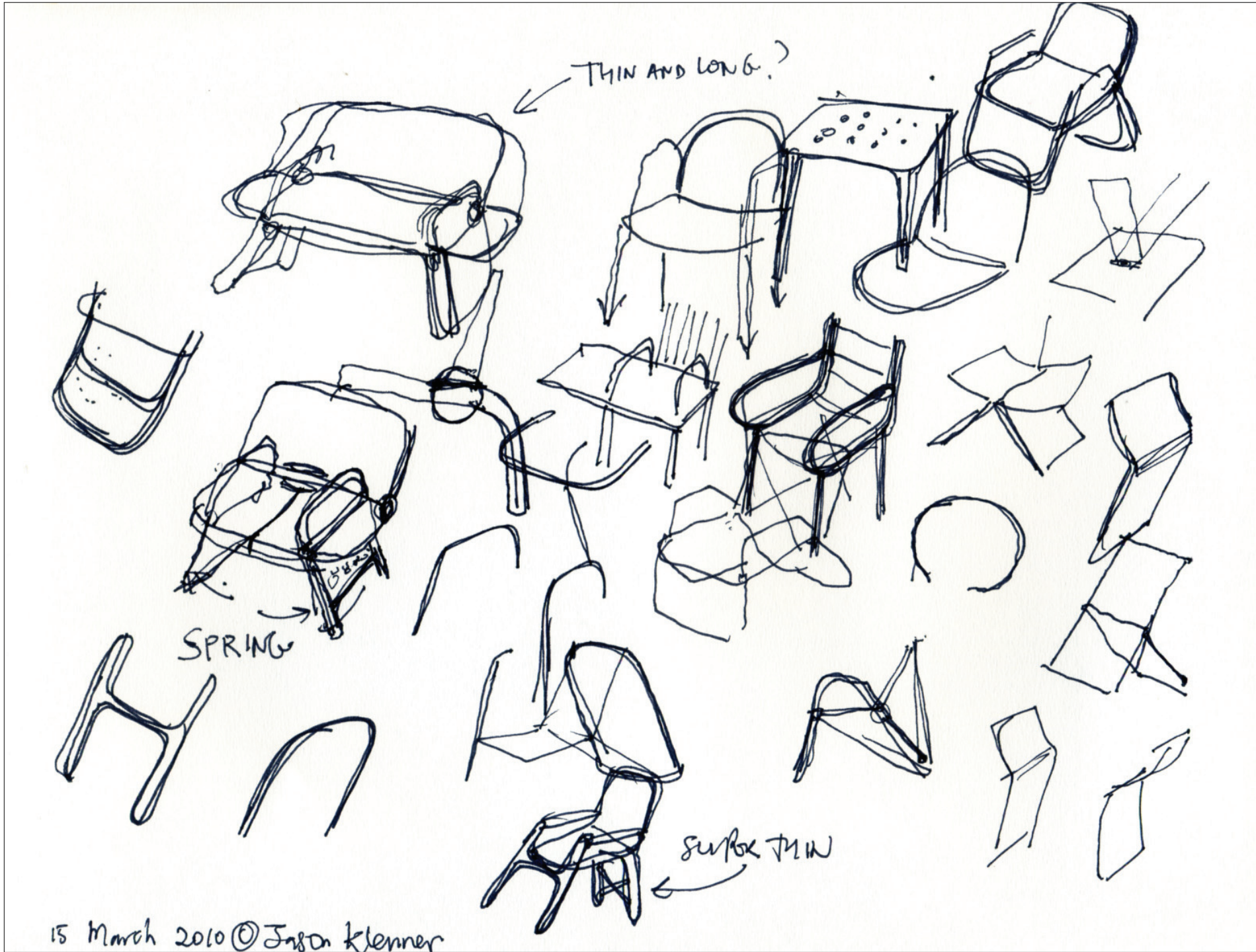

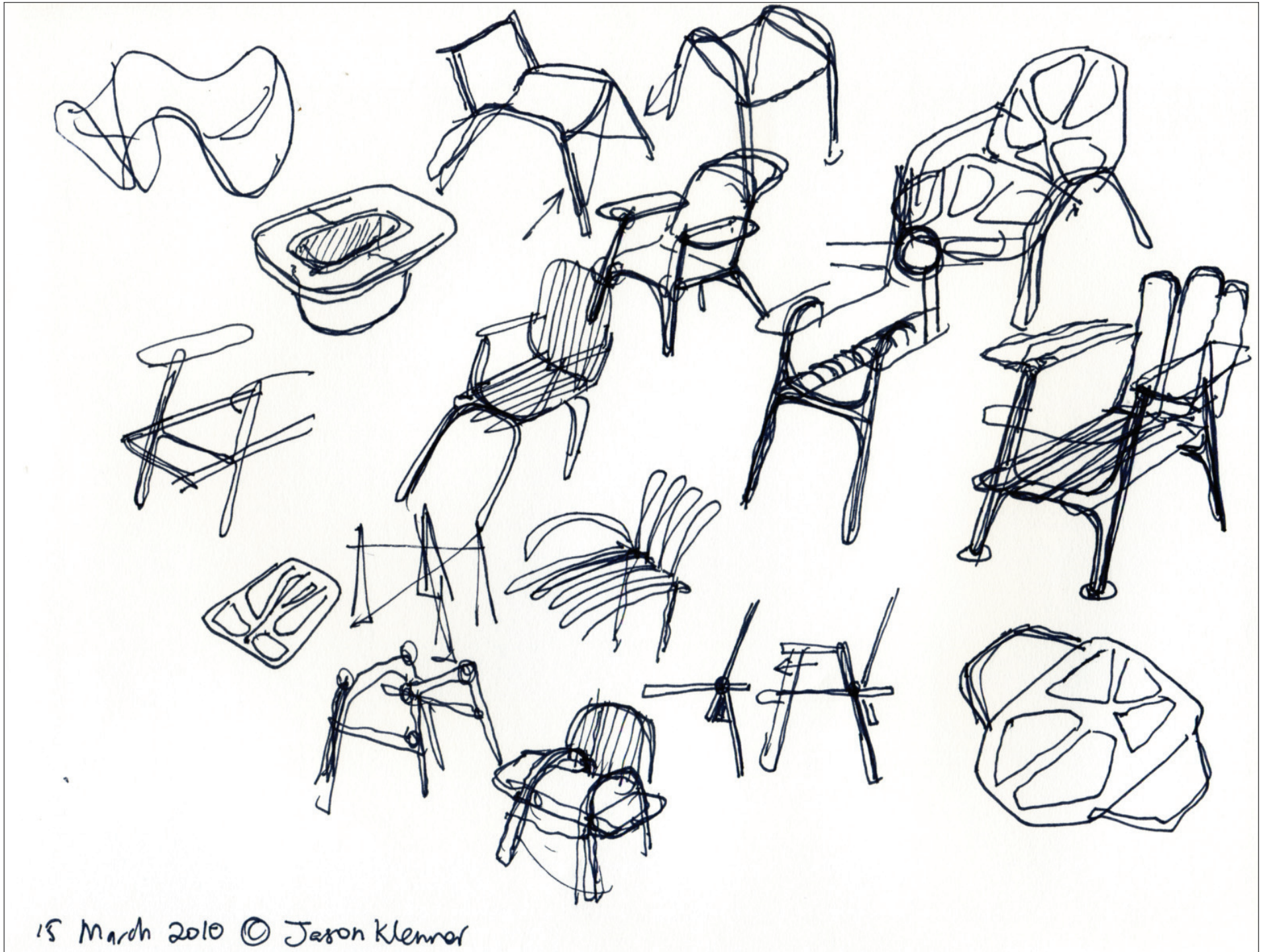

15 March 2010 © Jason Klemmer

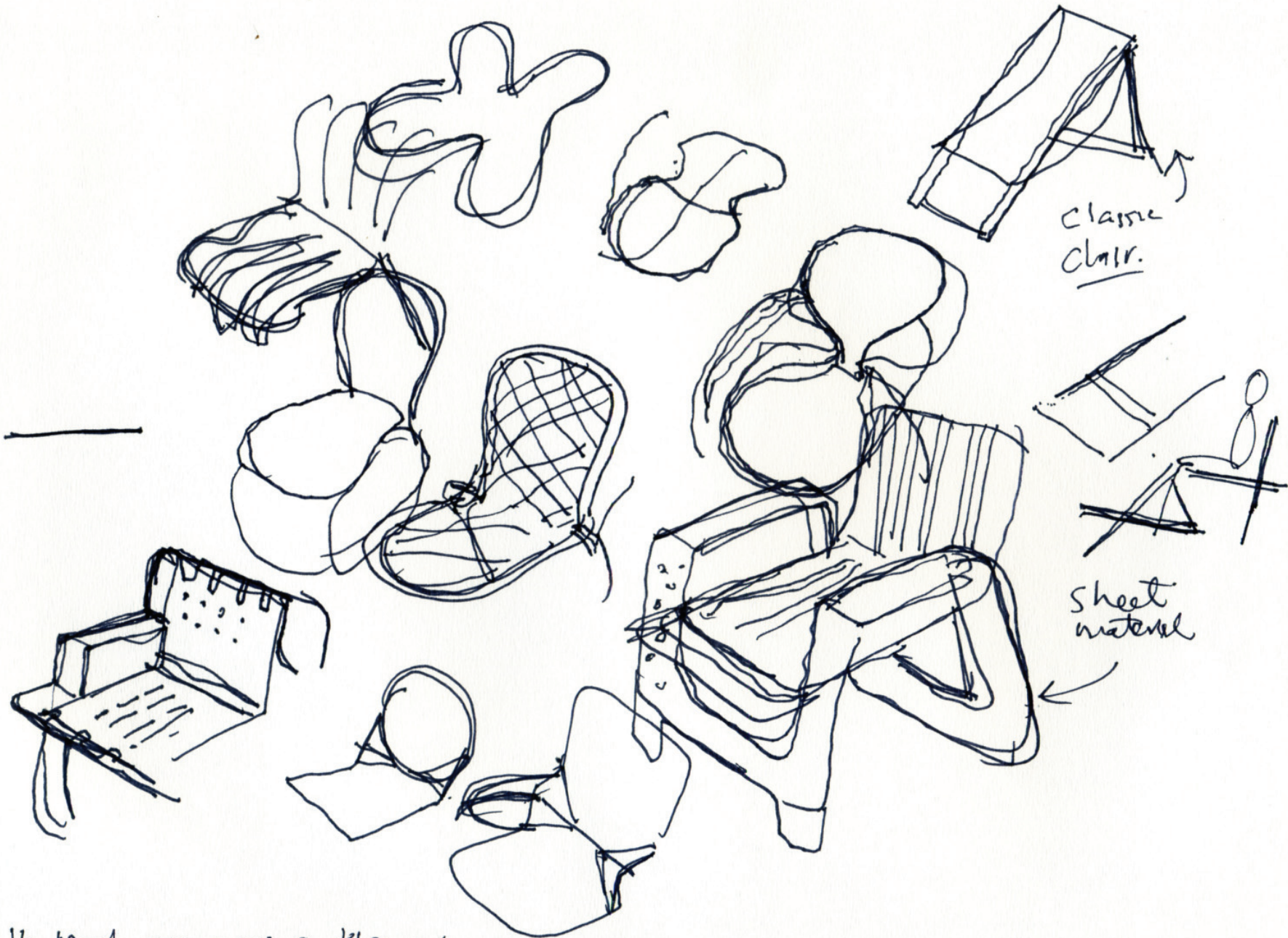

16 March 2010 © Jason Klenner

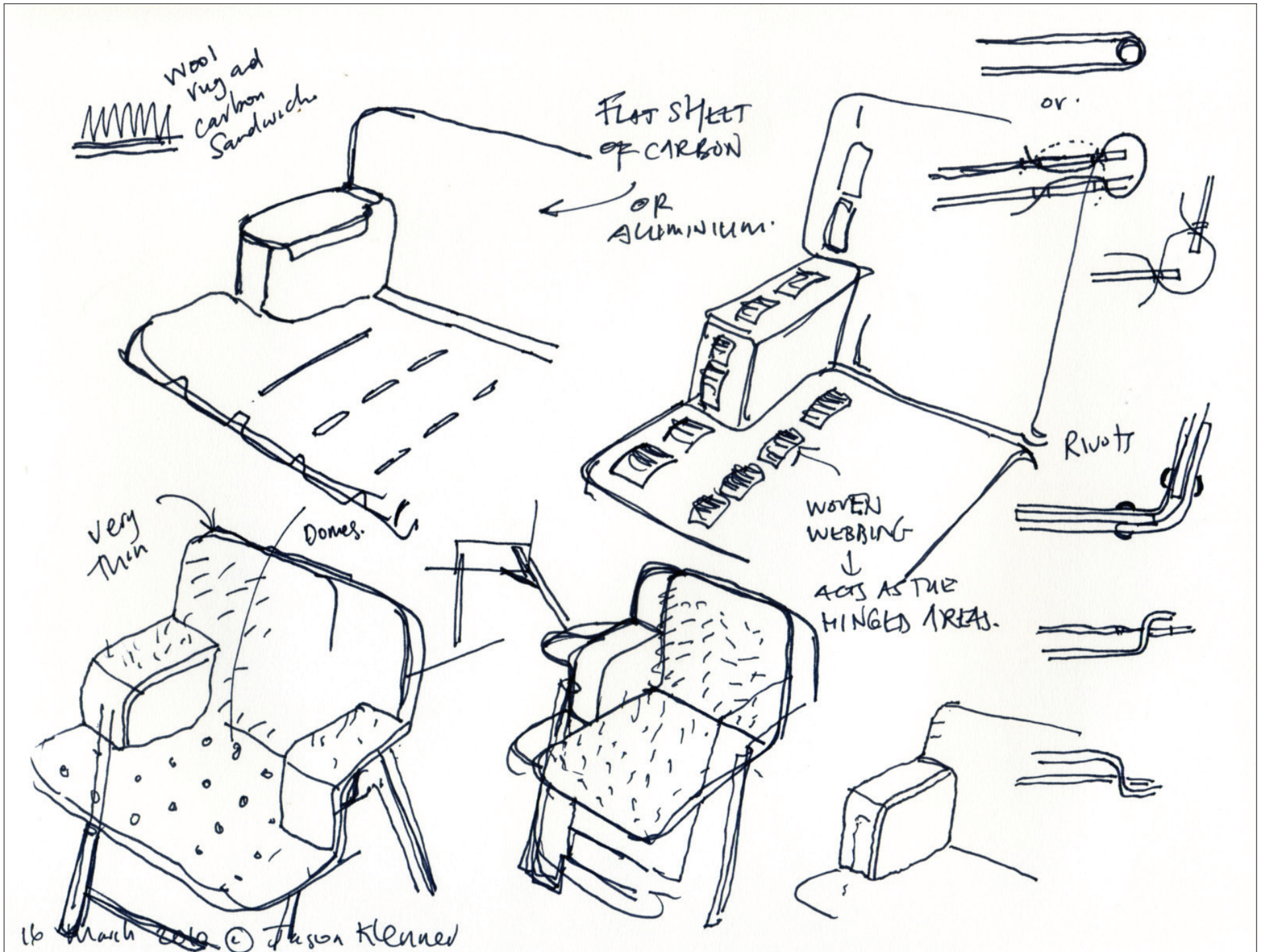

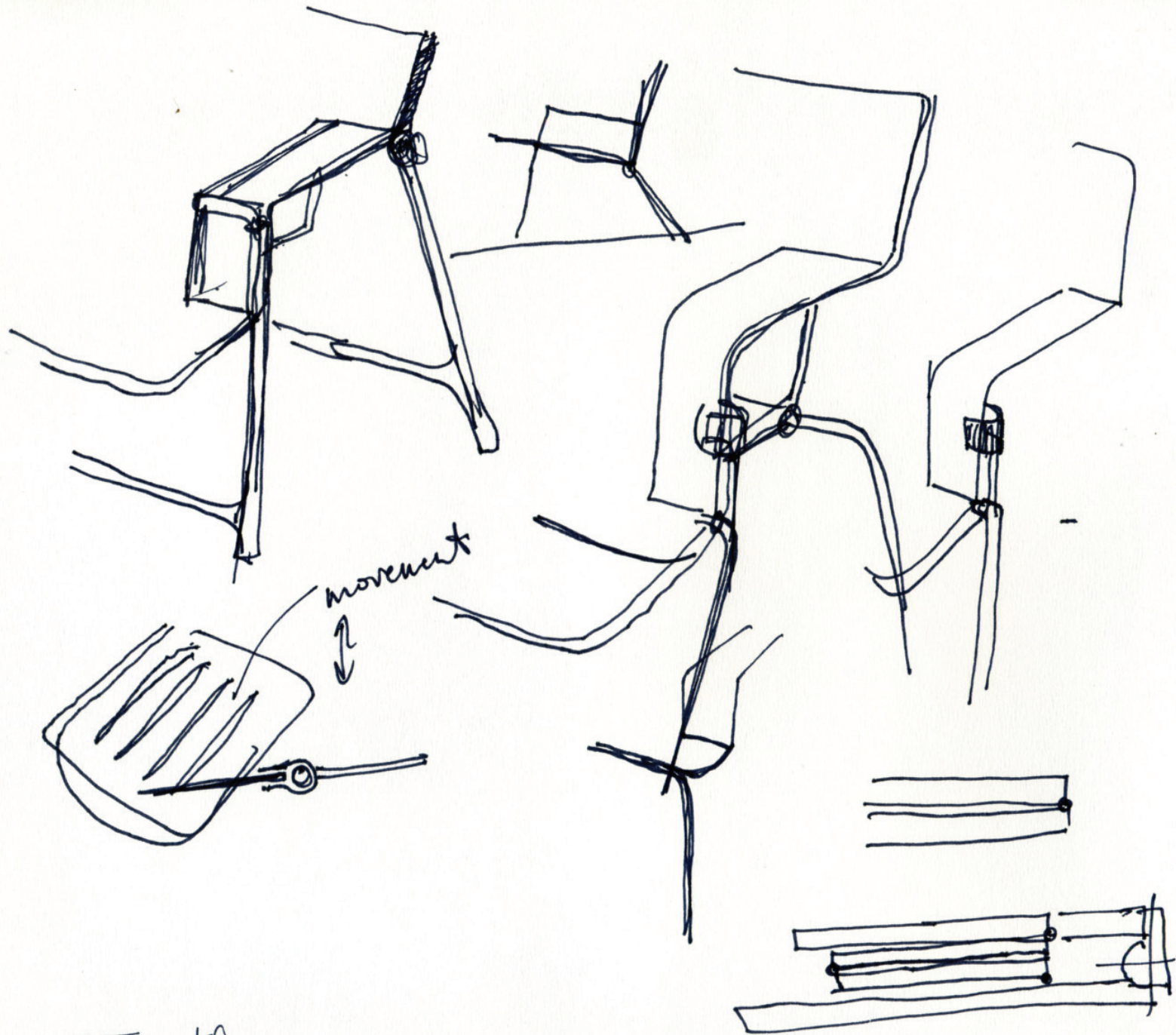

16 March 2010 © Jason Klemmer

# PICNIC FURNITURE: HIGH QUALITY PICNIC FURNITURE RANGE

- > HIGH PERFORMANCE AND HIGH QUALITY MATERIALS
- > SUPER THIN MATERIAL THICKNESSES
- > COMPOSITE MATERIALS
- > GREAT FOR PARK OUTINGS/ CONCERTS ETC.
- > SIMPLE, REFINED NOSTALGIC STYLE

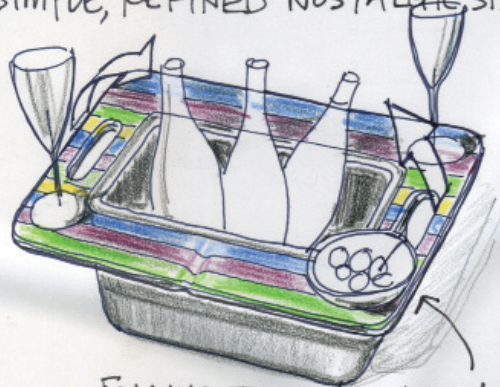

FOLDING TABLE/BASKET/CHILLI BIN

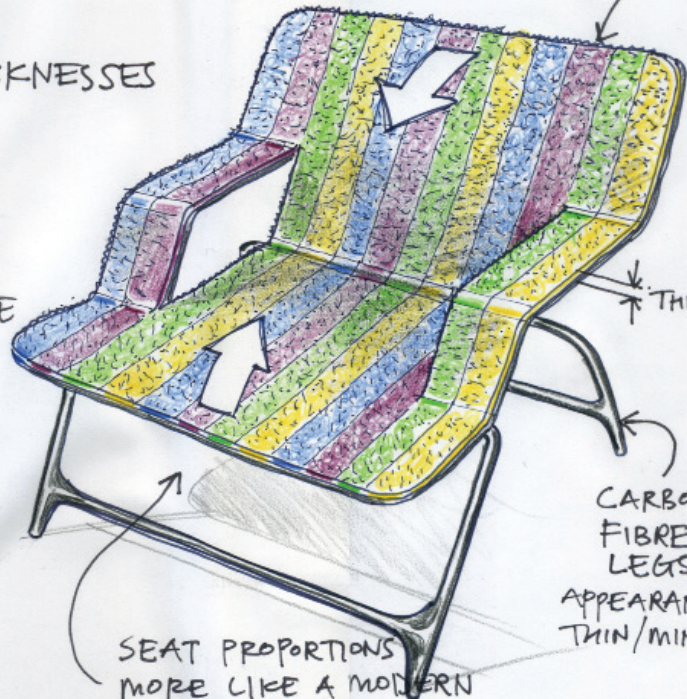

SEAT PROPORTIONS MORE LIKE A MODERN LOUNGE CHAIR. (WIDE, DEEP AND LOW TO THE GROUND)

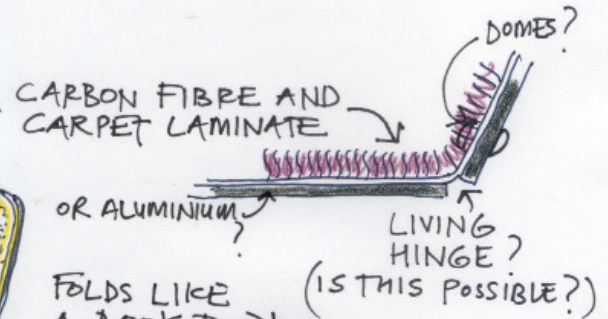

FOLDS LIKE A BOOK TO BE VERY THIN

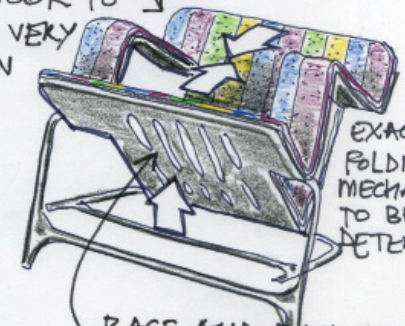

EXACT FOLDING MECHANISM TO BE DETERMINED

BASE AND BACKREST FLEX/COMFORT SLOTS

CARBON FIBRE LEGS. APPEARANCE = THIN/MINIMAL

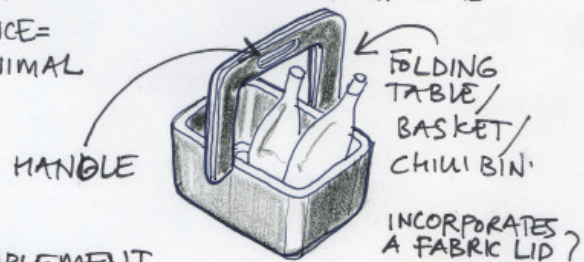

HANDLE

FOLDING TABLE/BASKET/CHILLI BIN

VISUAL REFERENCES:



ANTITHESIS:

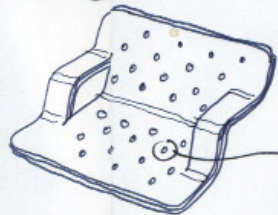

COULD COMPLEMENT THE TABLE TOP/PICNIC BBER PRODUCT?

DOMES SANDWICH CARPET (OR FABRIC) WITH CARBON FIBRE SHEET → DOMES = INDOOR FURNITURE AESTHETIC = COMFORT = 😊

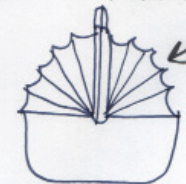

INCORPORATES A FABRIC LID?

© Jason Klenner 16.03.2010

# POST CRIT ONE REFLECTION:

17 March 2010 © Jason Klemer

JUST DO THE  
SPHERES → IT  
IS THE MOST  
DISTINCTIVE.  
(JULIEANNA)

LOCKHEED LOUNGE  
TYPE PRODUCT DAYS  
HAVE ENDED - THERE  
IS A DIFFERENT MODEL/  
PROCESS NOW TO BECOME  
ESTABLISHED (CHRIS)

THE CURRENT ECONOMIC  
SITUATION IS NOT SUPPORTIVE  
OF DESIGN ART (CHRIS)

A MODEL RANGE IS REQUIRED  
THAT IS UNDERPINNED BY A  
STORY OR AN EXHIBITION (CHRIS)

FINAL DETAIL DESIGN  
IS NOT REQUIRED →  
JUST ENOUGH TO GET  
YOUR FOOT IN THE DOOR  
WITH/FOR POTENTIAL  
LICENSING AGREEMENTS.  
(CHRIS) ↓

JUST DO A NICE RANGE -  
SOMEONE ELSE CAN WORRY  
ABOUT THE DETAIL.  
(LYN)

CONCEPTS LOOK COMPLEMENTARY  
→ BBQ + DECK CHAIR + WINE RACK

DO THE WINE RACK (NATALIE)

↓  
FOCUS ON THE EXPERIENCE

LOOK AT/EXPLORE THE  
TYPE OF HUMOUR TO BE  
USED IN MY PRODUCTS

↓  
WHAT IS THE SIGNATURE OF  
HUMOUR IN FURNITURE?



WHAT WOULD MAKE THE MASTERS  
CLASS LAUGH.?

TAKE IT TO THE PROTOTYPE  
PHASE.

THINK OF THESE PRODUCTS/  
RANGE AS A FASHION COLLECTION →  
THEY ARE CONSIDERED AS A SET.

ALTHOUGH THIS  
IS NOT FAVORED  
BY THE DESIGN  
SCHOOL →  
(FIND OUT WHY)

KARIN IS RECONSIDERING OUR  
EVERYDAY ENVIRONMENT.

LOCK IN THE HUMOUR/  
EMOTIONAL DESIGN INTO  
MY PRODUCT(S) (MARK)

CONCEPT 2 → INCORPORATE  
MORE SENSORY/PERSONALITY  
QUALITIES MARK

Combine concept 2 w. Th  
concept 5.

# POST CRIT REFLECTION:

RANGE SHOULD NOT INCLUDE 2 TYPES OF SEATING PRODUCTS.

PICNIC FURNITURE NEEDS TO FEEL.

APPLY A COMPLEMENTARY STORY ABOUT A NEW ZEALAND LIFESTYLE TO 3 OBJECTS

CONCEPT ONE:  
THE BASE IS IMPORTANT AS A LINKING ELEMENT ACROSS THE RANGE

EVERYBODY LAUGHED AT / WAS AMUSED BY THE PAGE / UPHOLSTERY IDEA

THE MILAN FAIR IS NOT THE EXAMINER.

CREATE KEYWORDS TO EXPRESS ME

CREATE KEYWORDS TO EXPRESS MY VIEW OF NEW ZEALAND (WORD COMPUTATION)

CREATE KEYWORDS ABOUT WHAT I WANT FROM THE AESTHETIC

## UNDERSTAND THE DIFFERENT TYPES OF HUMOUR

HUMOUR IN A PRODUCT.

- > SHAPE.
- > DETAILS
- > FUNCTIONS
- > COMBINATIONS

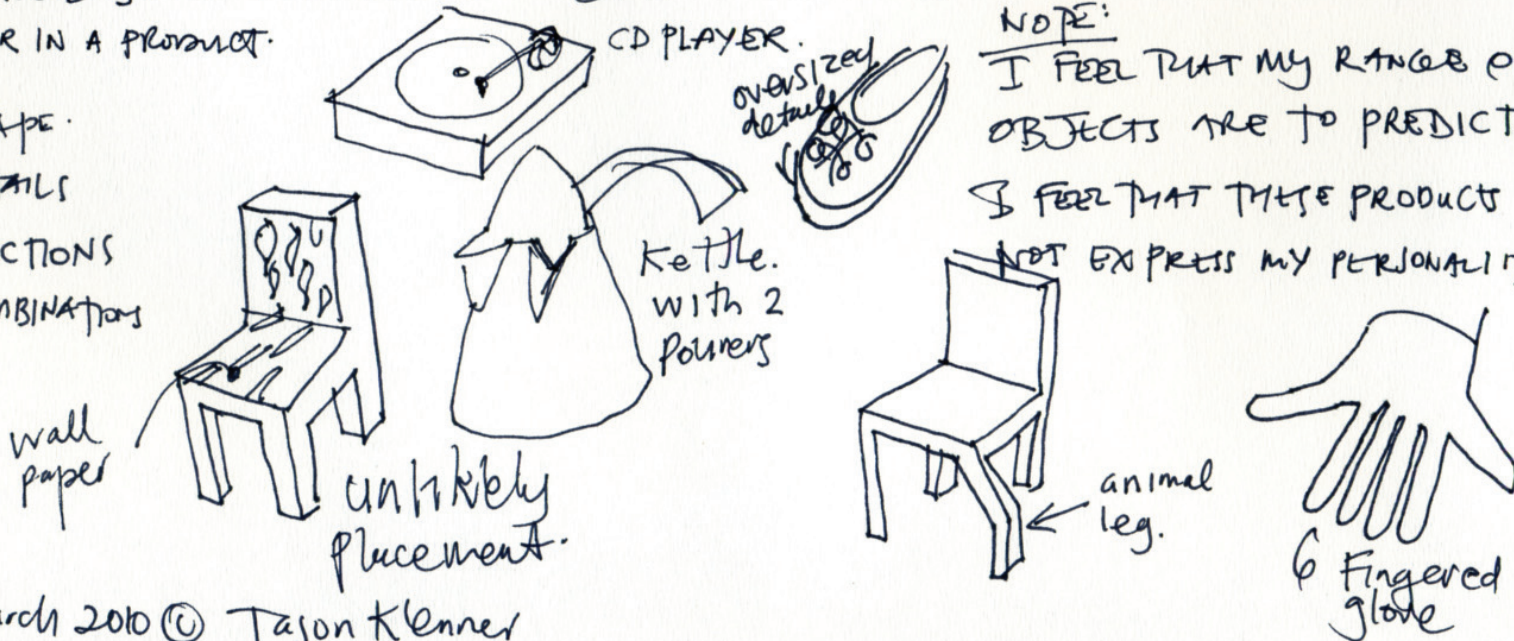

NOTE:  
I FEEL THAT MY RANGE OF OBJECTS ARE TOO PREDICTABLE.

I FEEL THAT THESE PRODUCTS DO NOT EXPRESS MY PERSONALITY

17 March 2010 © Jason Klenner

HUMOUR = medicine?

repetition = funny?

Placing one behaviour in another area.



CONTRAST/  
CONTIDITION.

childs  
playpen



how about  
MERGING 2 x  
social/moral  
point of views

ANIMAL/HUMANISING  
PRODUCTS

SOCIAL  
EXCLUSION



ANIMAL  
BTRD OF  
& GUN



What type of humour do  
I want?

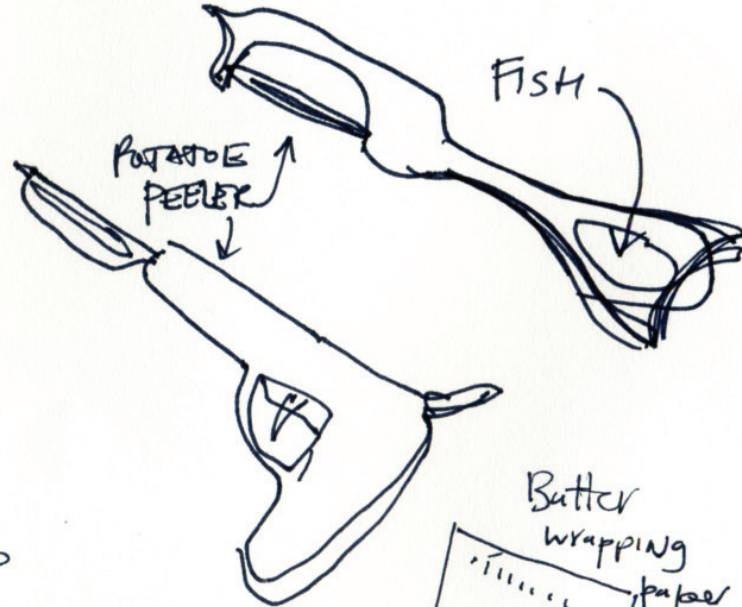

Nostalgic humour

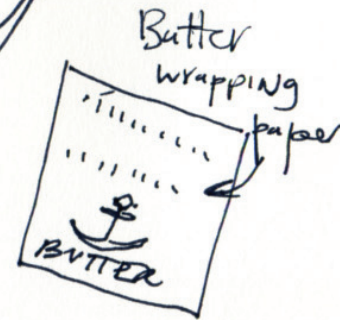

17 March 2010 © Jason Klenner

Light hearted!!

- Refreshing
- not too serious.

How do you ~~create~~ <sup>create</sup> light-hearted ~~bbq~~?



Perm.

Buzz saw



MAY NEED MORE THAN A VISUAL SIGNATURE →

FOR EXAMPLE → IS STYLING NOW CONSIDERED NOT ENOUGH.

WORD PLAY.

HOW CAN I TWIST/DISTORT A NEW ZEALAND POINT OF VIEW

BAA BAA CUE  
FOR LAMB RACKS.

New Zealand  
Areas for/of  
abstraction:

GIDDAY CHAIR  
BAA STOOL  
MOOMOO CUE

- sheep - outdoors - nature.
- flowers - beach - Flight of the Conchords
- water - boats - bogans

17 March 2010 © Jason Kleme

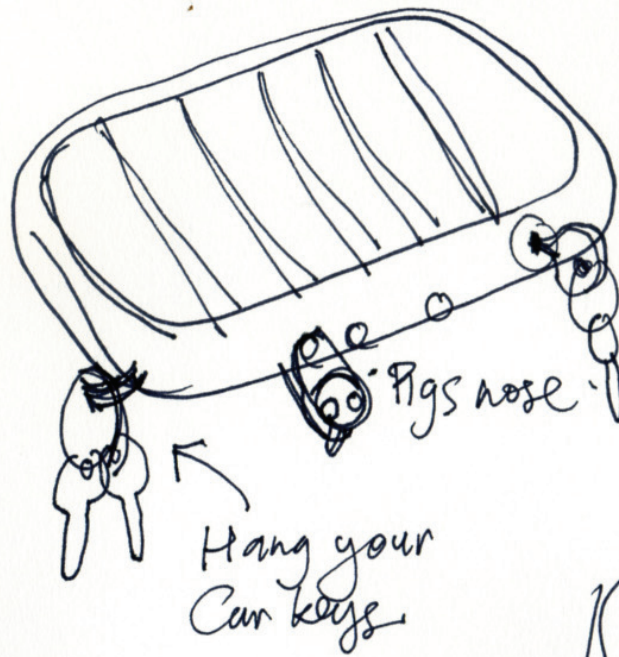

IS HUMOUR  
My THING ?



IS IT ELEGANT/  
ROMANCE.

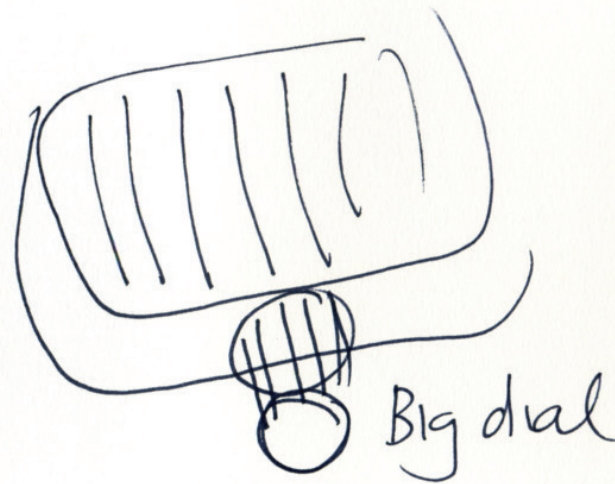

BEHAVIOURAL  
DESIGN →  
WHAT FUNCTION  
DOES IT OBJECT  
PERFORM  
PP 70  
EMOTIONAL DESIGN

17 March 2010 © Jason Koerner

Humour, like comedy, consists of a negative expressive element, a positive element, and a resultant

- > Thought Provoking.
- > Socialable.
- > functional
- > energetic
- > considered?
- > restrained?
- > reliable
- > Joyful.
- > intentional?
- > simple?
- > Happy
- > Gentle
- > Calming?

Psychological mood pp. 56 why bowk  
Laugh and cry - Moses Briny

Sociologists saw it (laughter/humour) as a means of social control to redress and punish non-conformists pp 37

What type of emotions do I want to engage?

AM I ABOUT BEING LIGHT HEARTED →  
NOT TOO SERIOUS.  
ABOUT THE EMOTIVE NOT THE TECHNICAL

NOT TOO SERIOUS

23 March 2010 © Jason Klemmer



A degradation of values (Stem)

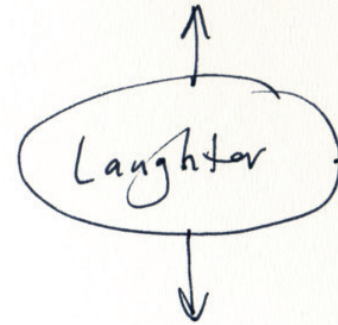

A juxtaposition of the living and the mechanical (Bergson)

Reaction to a perception of an incongruity (Kant, Schopenhauer)

"Funology."

Check out: "Positive Psychology"

or Positive emotions of product design  
Positive emotions, Product design

Google brand image: "Fun for the user of the site, good reflective design, and good for business" pp 104 Emotional Design

Fun  
Playful.  
unexpected →  
not unusual.

THREAD = JASON'S PERSONALITY + NEW ZEALAND PERCEPTION + DESIGN CRAFT

Jason = Light hearted ?? unexpected details  
= Gentle / delicate ?  
= Unexpected → surprise ??



24 March 2010 © Jason Klenner

Jaime Hayon's shapes are a reflection of his Spanish/European upbringing.

horse/saddle animals.

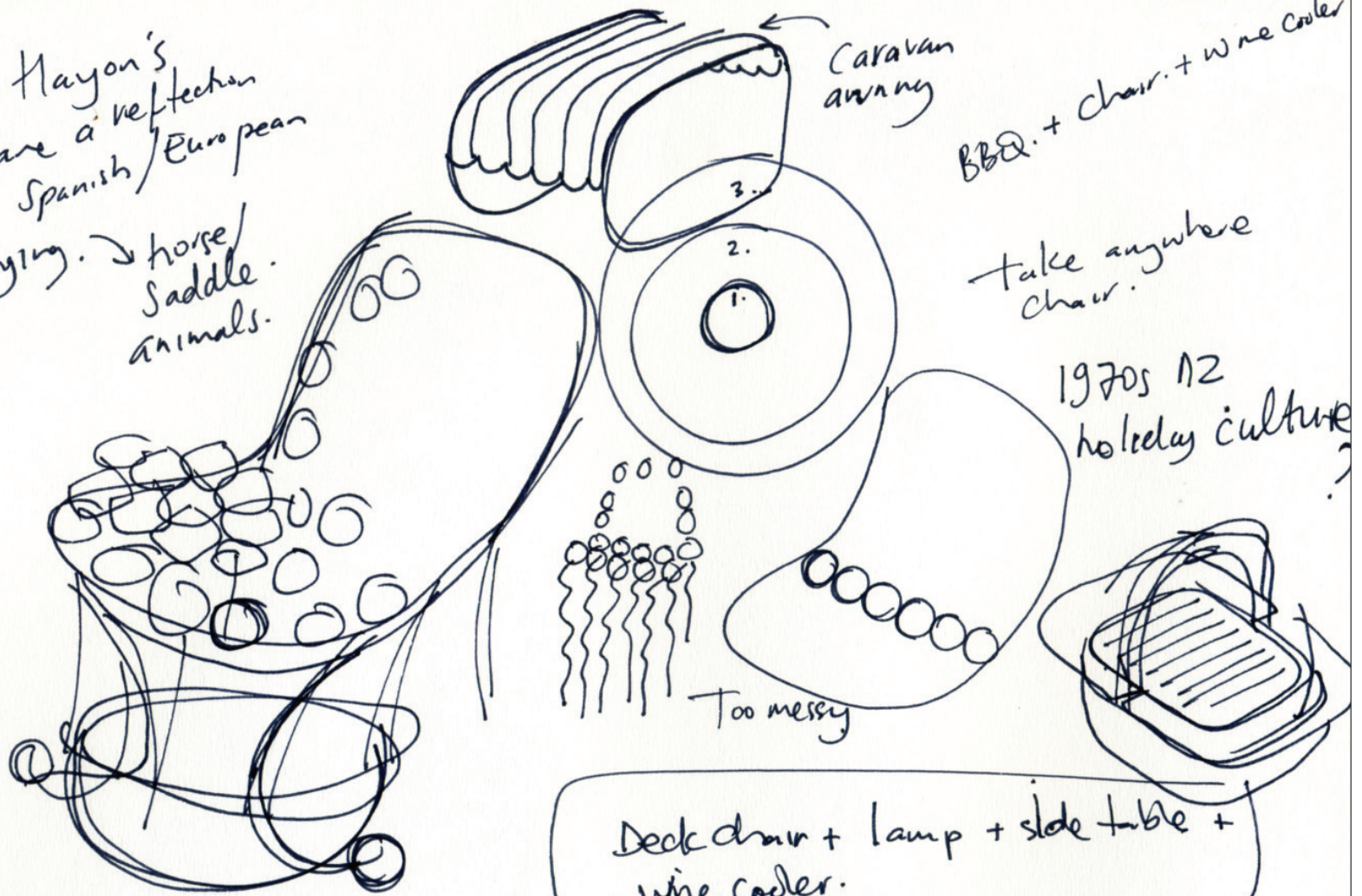

- 1. Deck chair
- 2. side table.
- 3. wine cooler.
- 1 Deck chair

What is the story → sifting at home.

Deck chair + lamp + side table + wine cooler.

Outdoor chair. + outdoor lounge + ~~lamp~~/table/ wine cooler.

24 March 2010 © Jason Klemmer

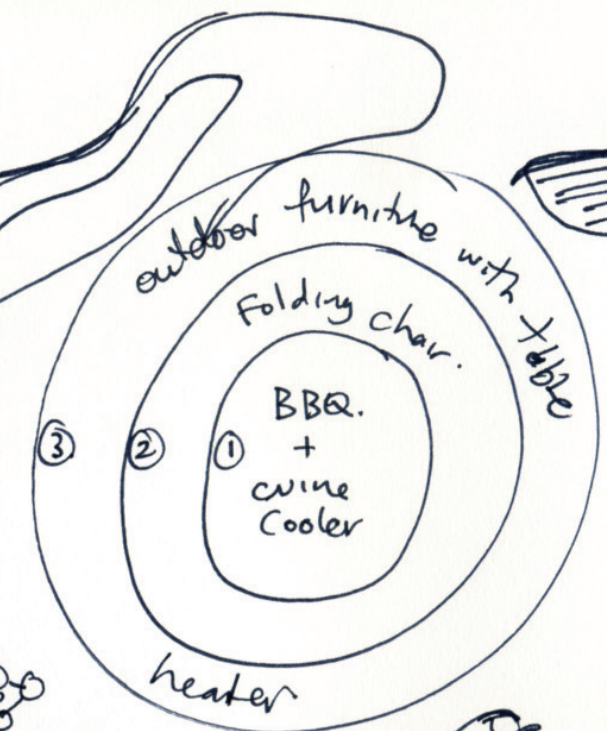
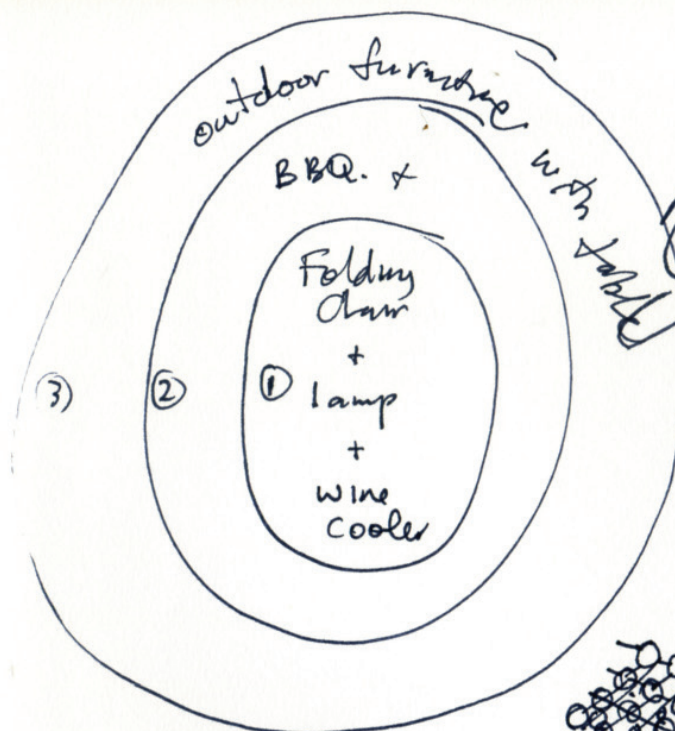

Pages/sleeves = flexible furniture.  
Folding Chair:

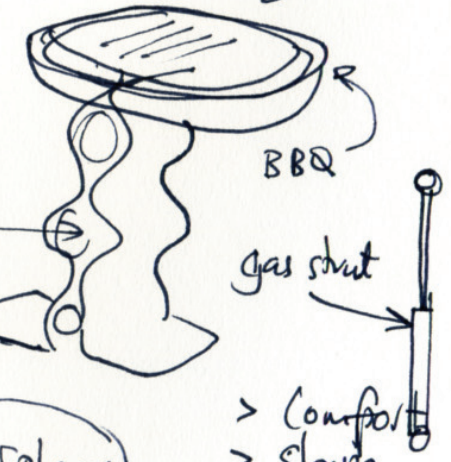

option 1.

option 2

Where is the light hearted aspect?

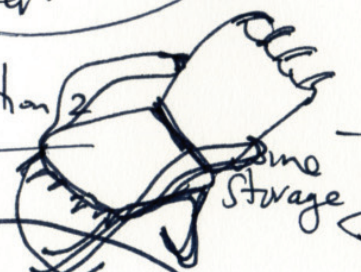
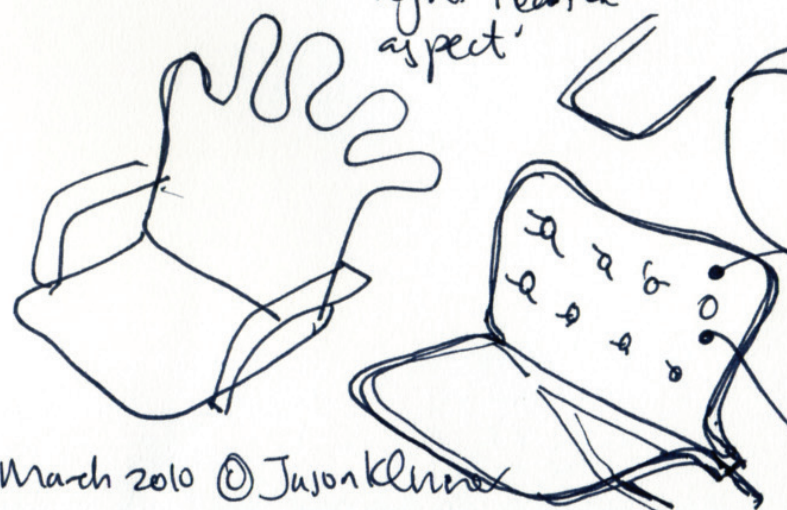

2: #. Spheres

- > Comfort
- > Shape
- > materials

Transforming the traditional outdoor folding furniture into a high value item

→ more sculptural → desirable emotive.

24 March 2010 © Jwanklenn

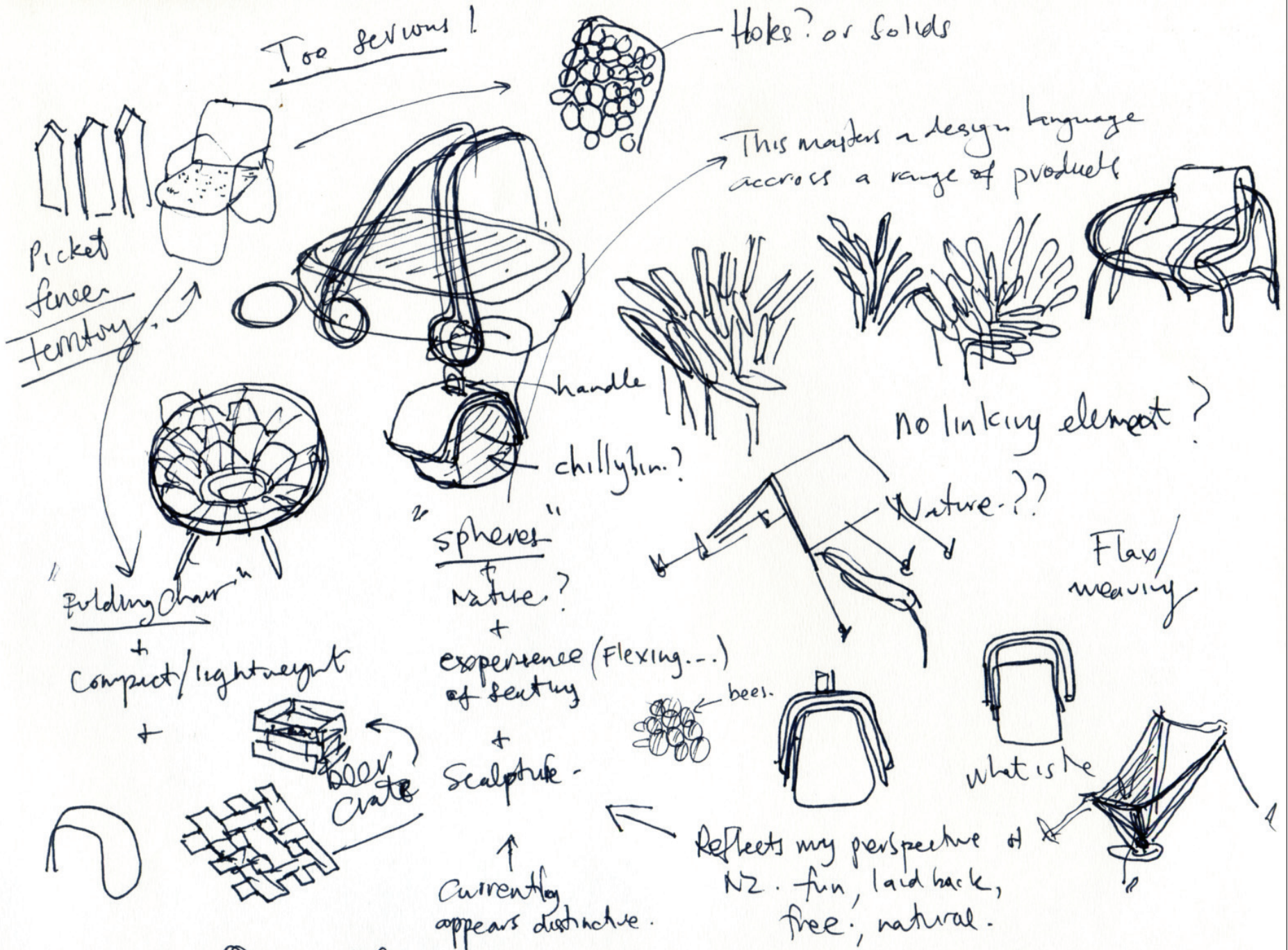

25 March 2010. © Jason Klemmer

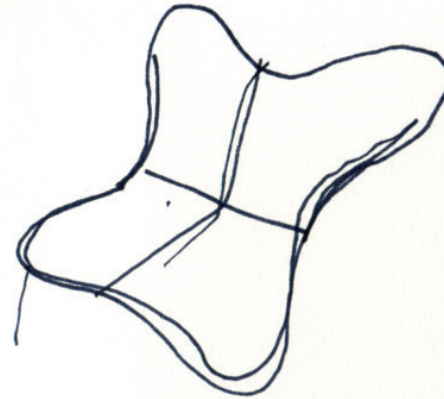

umbrella.



outdoor  
loungers./  
non-functional  
furniture!

↓  
Sculptural.  
↓

25 March 2010 © Jason Klenner

~~approach 1~~  
→ 3 good ideas - take to milan  
~~approach 2~~  
access market

do not use the process to conventionalise this →

take outrageous risks  
academic investigator  
fuel me up as far as creativity.

cover or wool into a 3d shape

Taxi driver  
net → ball  
net of balls.

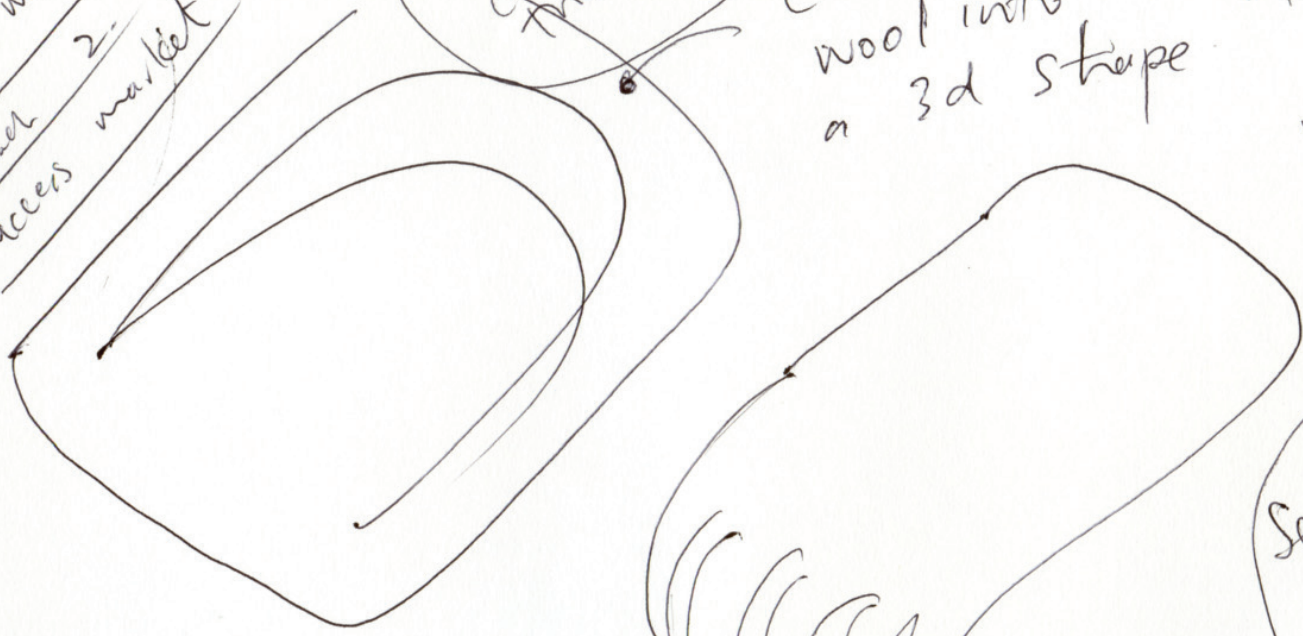

Semi solid surface in the spiral design

Integrity = high → cannot do something

design process → ①  
create ideas

design process → ②  
building, helps

Charity, helps solution  
a unique approach

Feet

deep learning will come from the next phase → rendering materials

Skype Conversation 29 March 2010.

deciding → Problem → too many ideas.

Juleanna:  
Concerned →

2 levels → idea generation loop  
→ bottleneck → She could not see  
the theoretical ~~and~~ underpinning  
of this →

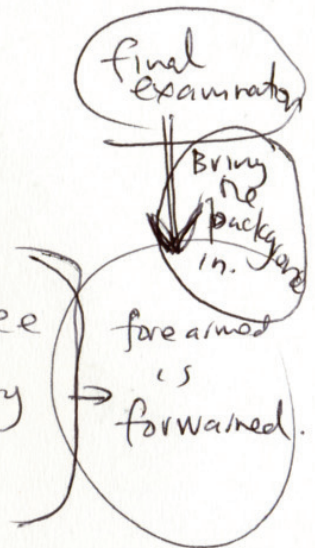

---

Combine - new concept with "swatches" )))

→ 2 types of products

play full

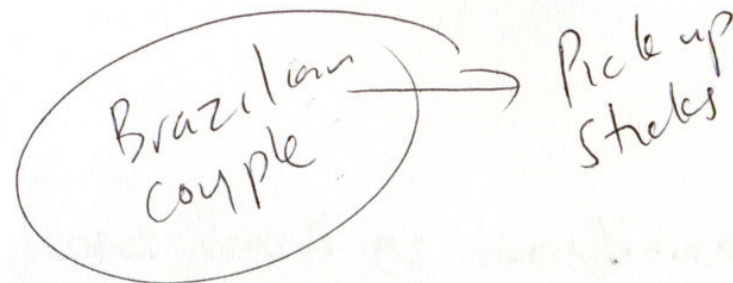

Small chapter  
Exe. thesis. → 3-4  
page  
Snapshot

Provide  
a market  
overview

These are the  
things that are  
close to it

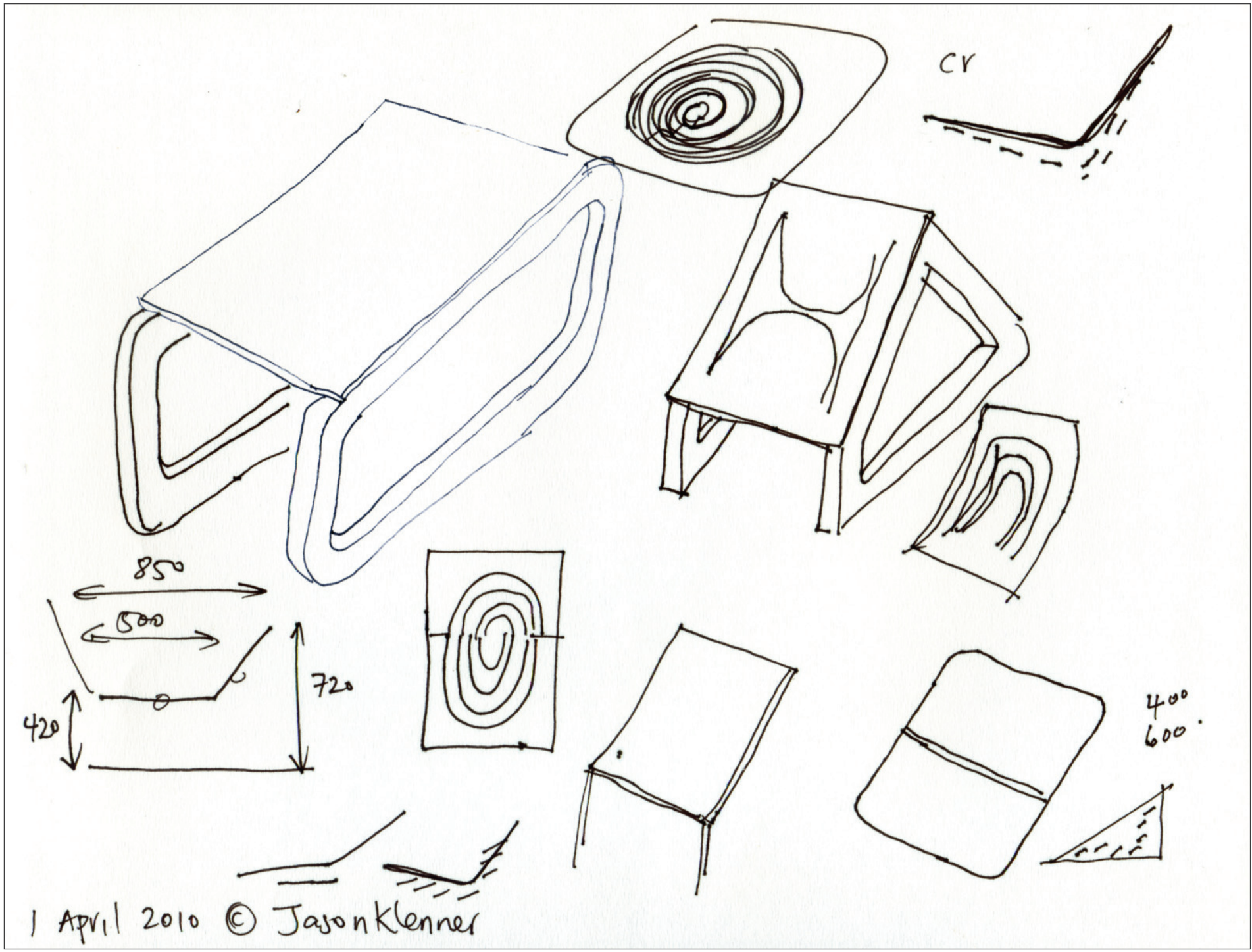

1 April 2010 © Jason Klenner

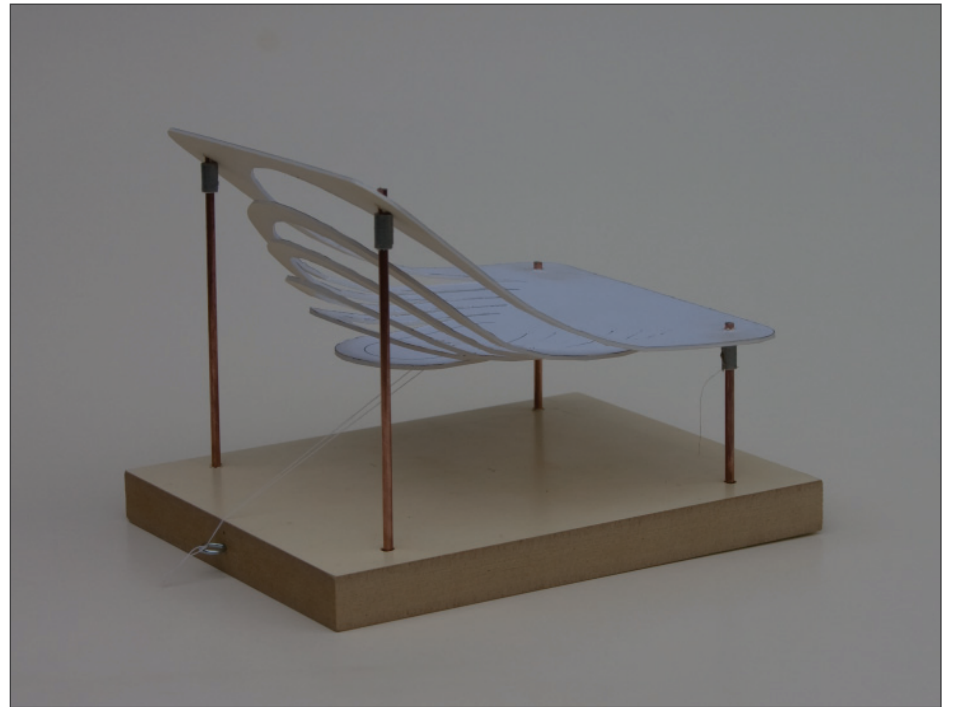
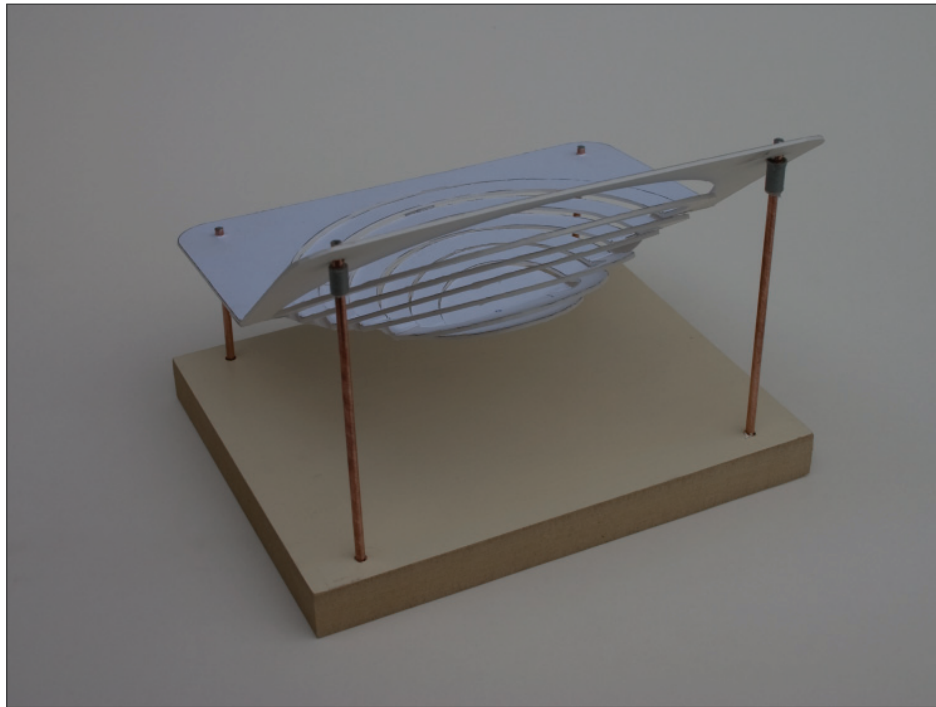
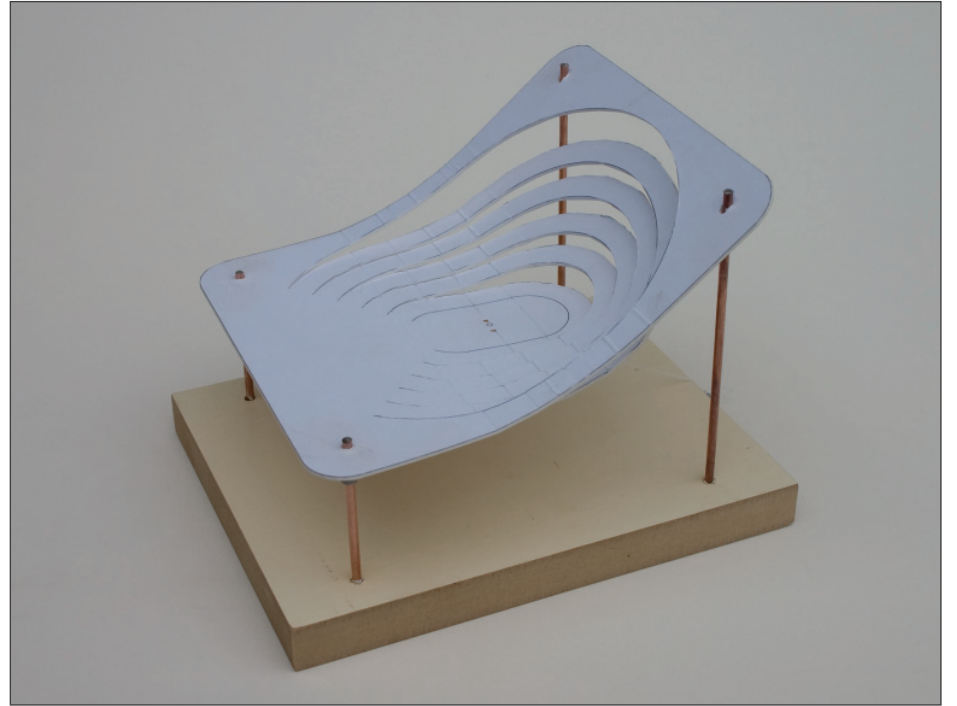
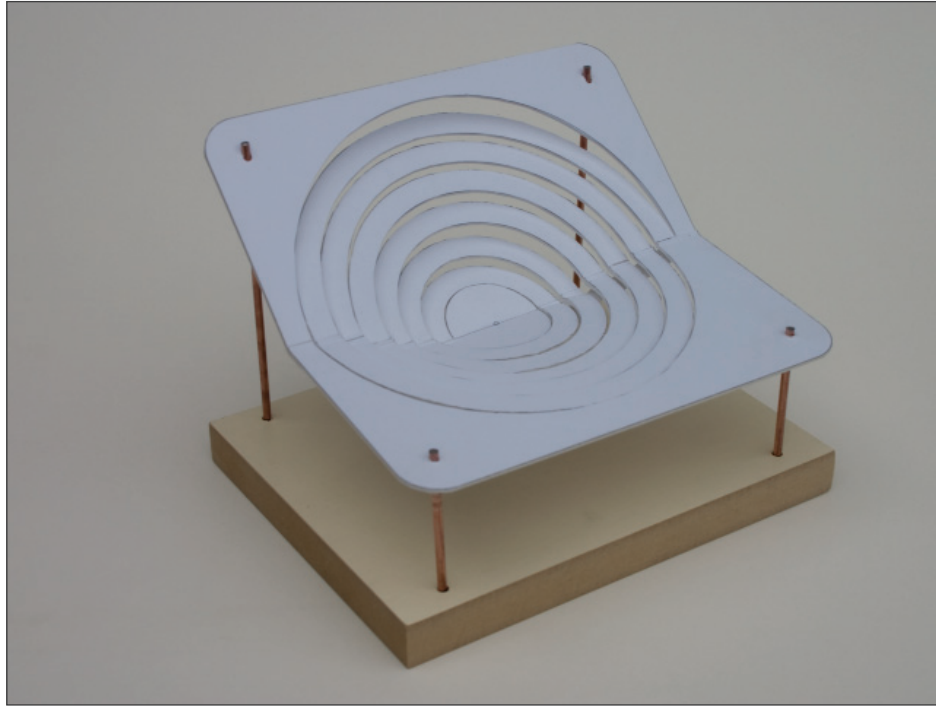

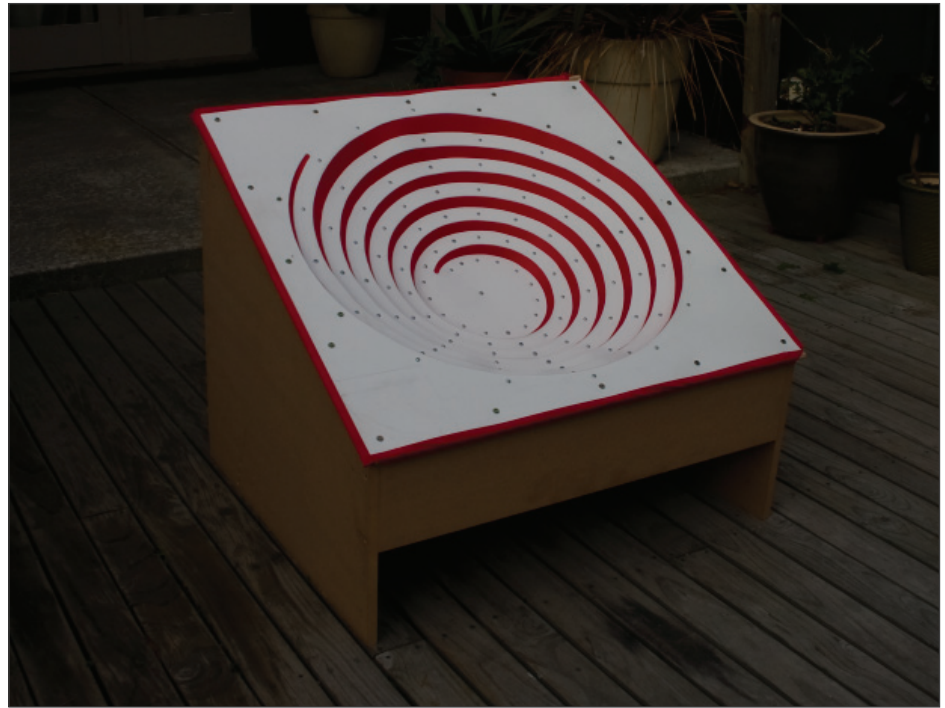
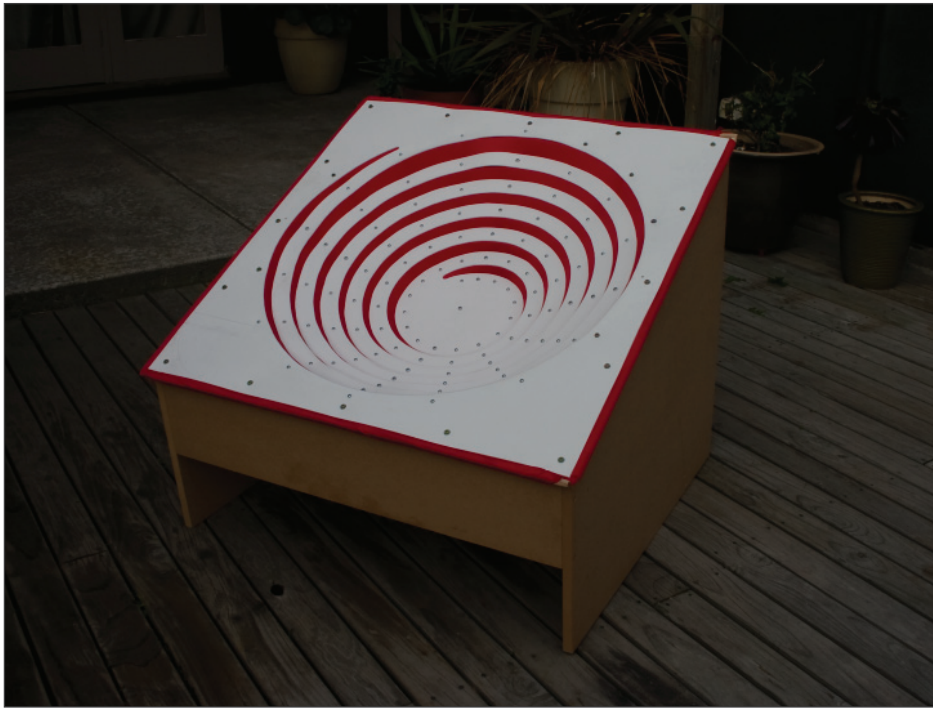

EVOLVING THE KEY ELEMENTS OF CONCEPT ONE.

PROTOTYPE ONE EVOLUTION  
 Single skin of material

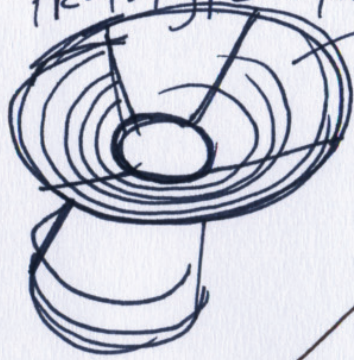

Spiral -  
 too flexible  
 in plastic. →  
 metal? →  
 Steel.  
 Aluminium →  
 Natural Spring?

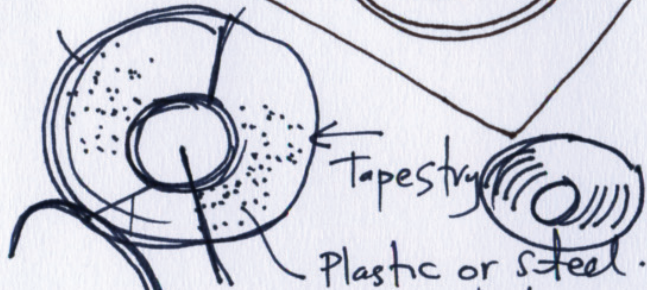
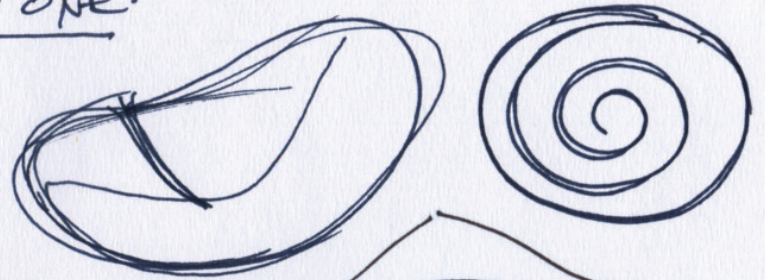

Plastic or steel.  
 what is it  
 that I do  
 not like about  
 prototype 1..?

What do I want  
 to achieve with  
 this →  
 adjustable?  
 outdoor?  
 natural flex?

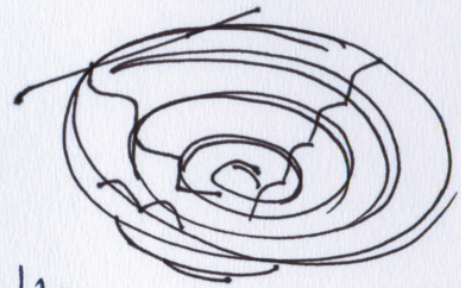

- too flexible
- square size is too large

I like the cup  
 shape.



7 April 2010 ©Jason Klenner

PROTOTYPE ONE EVOLUTION:

Rocker.

flex

"rigid."

Too much Spring.

Too conventional  
processes.

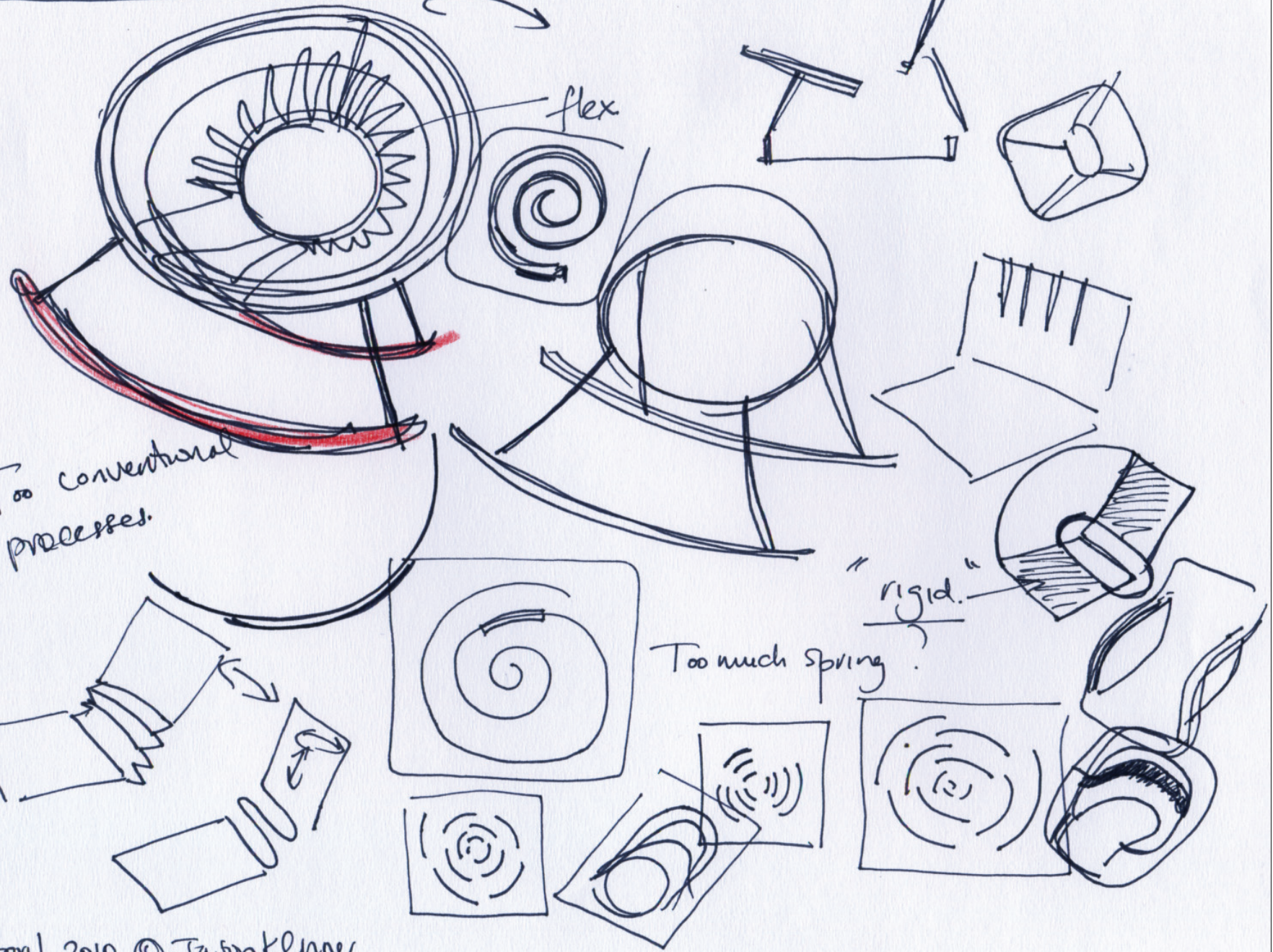

7 April 2010 © Jason Klener

EVOLVING THE KEY ELEMENTS OF CONCEPT ONE

PROTOTYPE ONE EVOLUTION:



7 April 2010 © Jason Klenner

PROTOTYPE ONE EVOLUTION

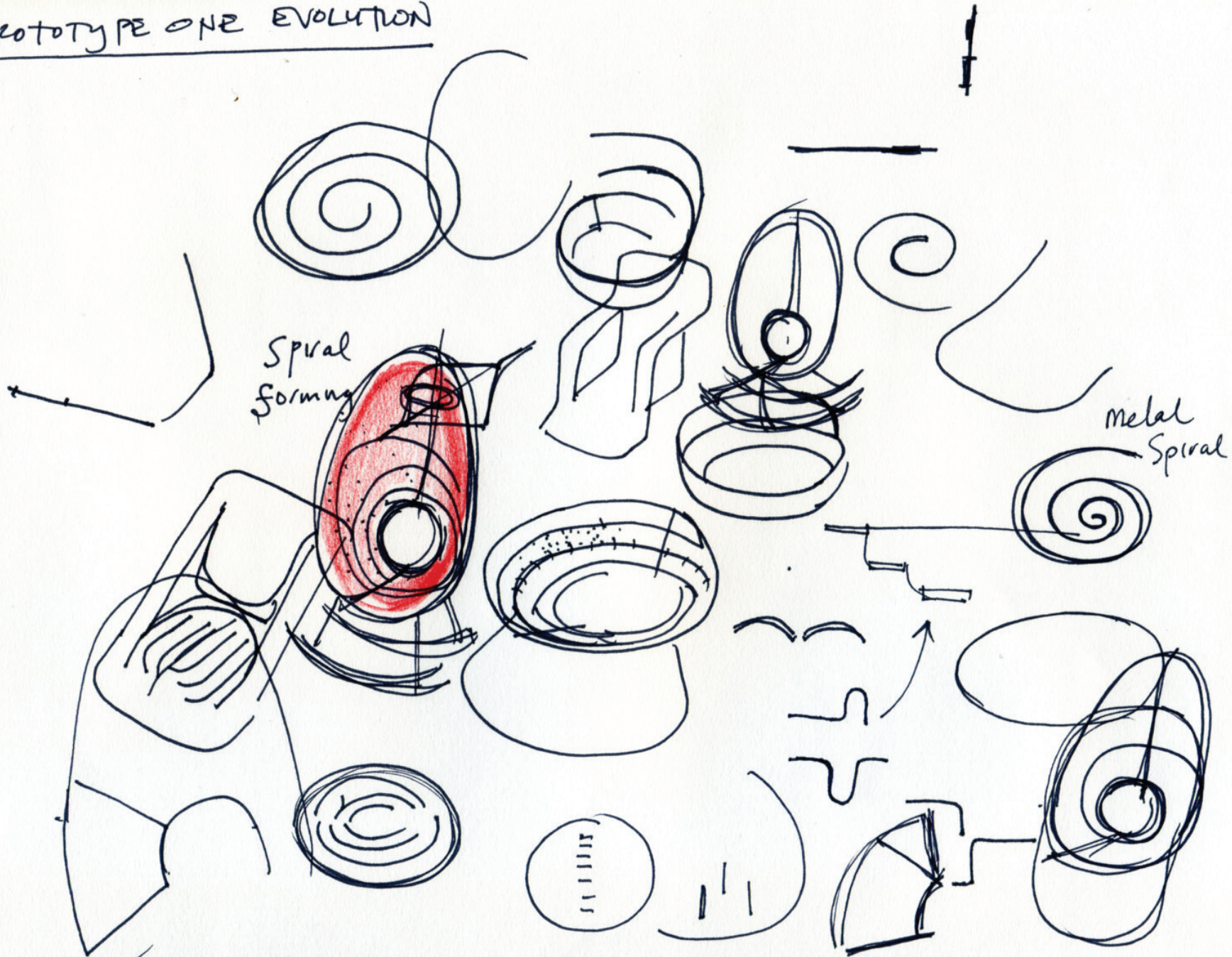

7 April 2010 © Jason Klenner

# Prototype One: Critical Reflection

Haircut needs improving.

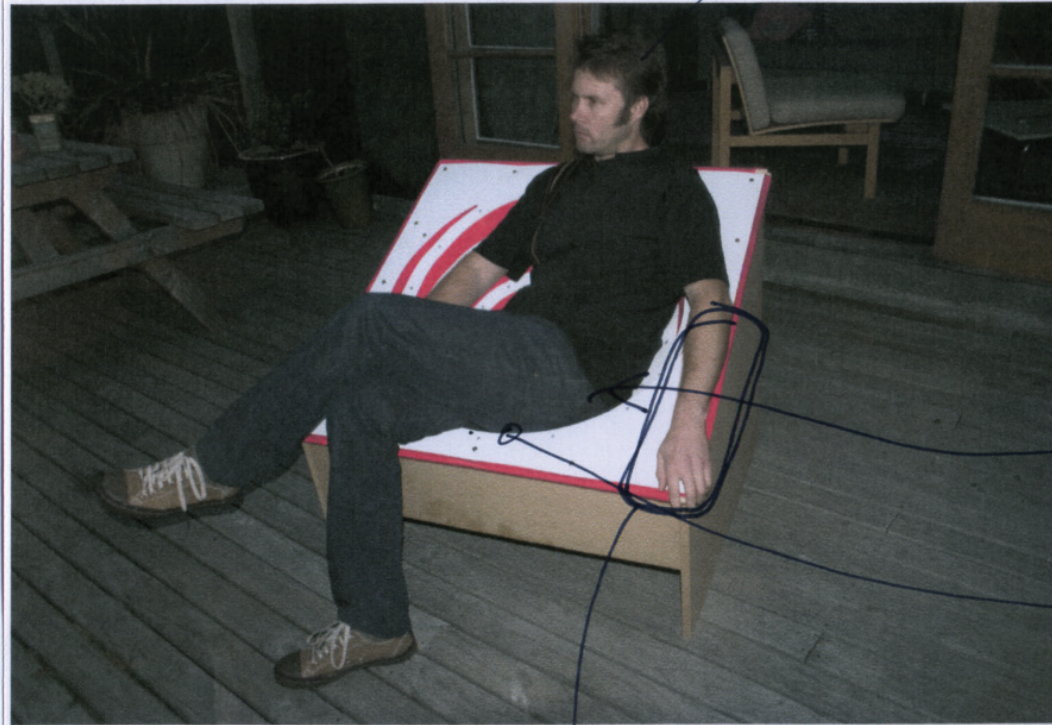

Circular shape of cavity allows seating in many positions

Sharp/uncomfortable edge.

Good armrest zones.

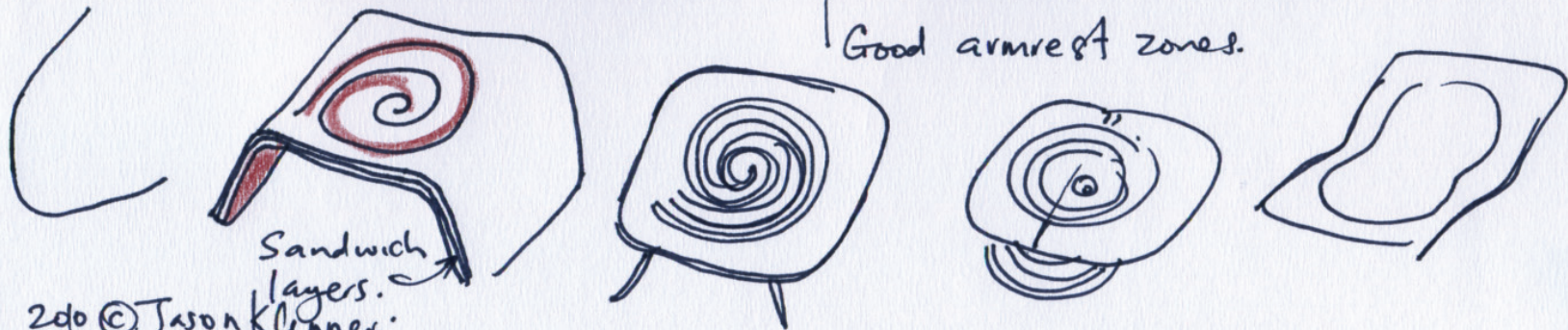

Sandwich layers.

9 April 200 © Jason Klenner.

# Prototype One: Critical Reflection

Prototype objective: proof of principle. (spiral shape + lycra. can create a seating system)

Polypropylene Sheet. (3mm thick) top and bottom.

850mm

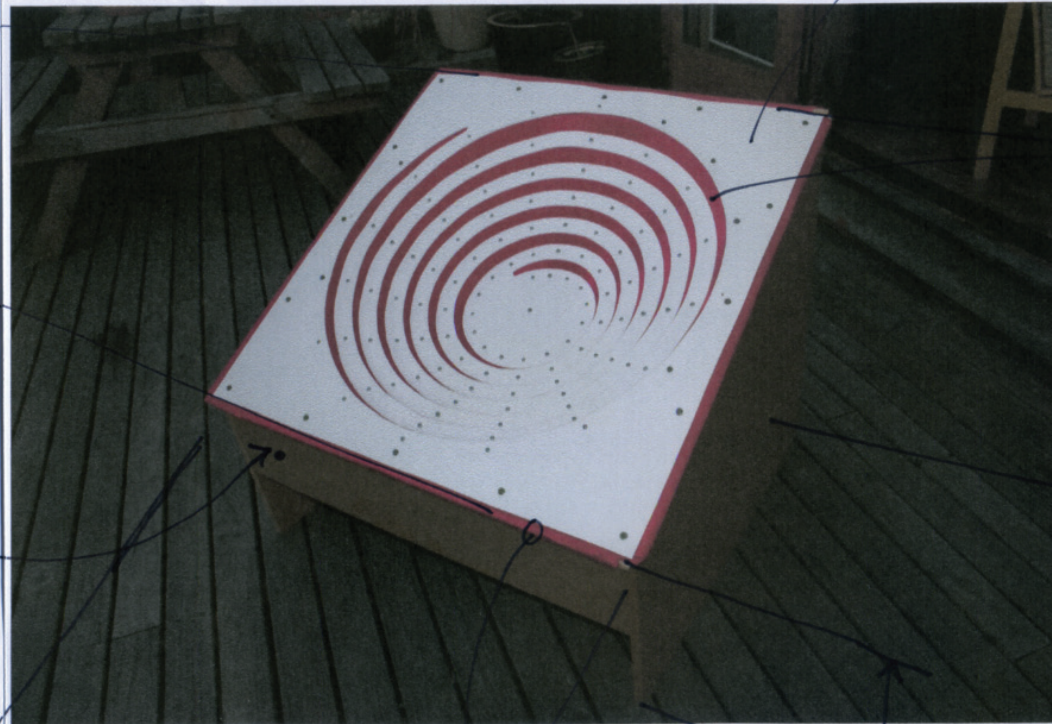

Lycra. (4x layers)

750mm

Chair type:  
outdoor / relaxing chair

Frame is too bulky / not elegant

without the lycra → The polypropylene is too flexible → too many revolutions.

360mm

850mm

Dowels tension the lycra.

Current status provides a comfortable level of natural spring.

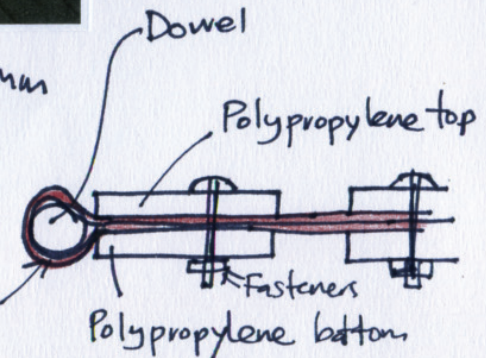

9 April 2010 © Jason Klener

# Prototype One: Critical Reflection

size of planar surface feels about right.

planar surface provides an adequate level of comfort and appears. / reinforces the appearance that the seat is cut from a sheet of material



Cavity created is more comfortable than it appears to be.

Circular shape of cavity allows seating in many positions

Concentric edge is too sharp.

Corner is very bulky.

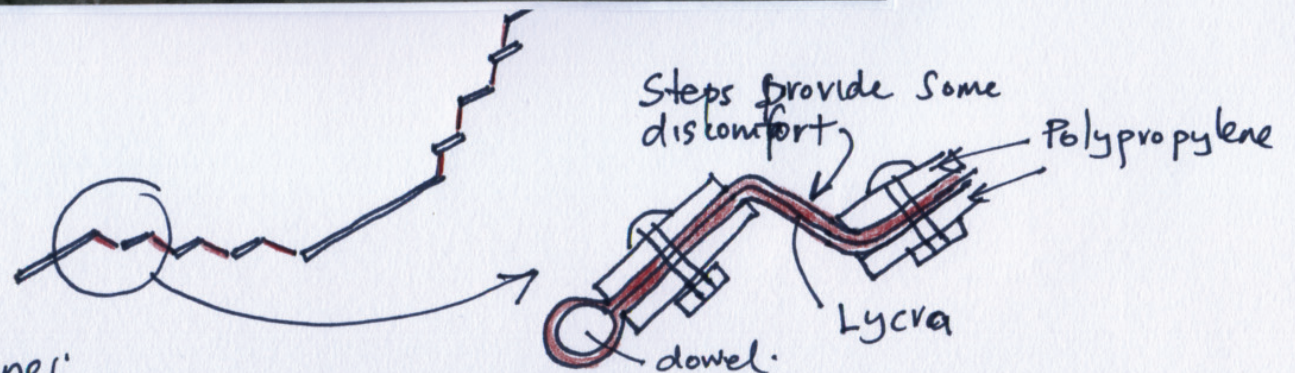

9 April 2010 © Jason Klenner

# Prototype One: Critical Reflection

Has the potential to look striking

Polypropylene is bulging up

Colour contrast is good.

If this idea was pursued. Screws would need to be eliminated.

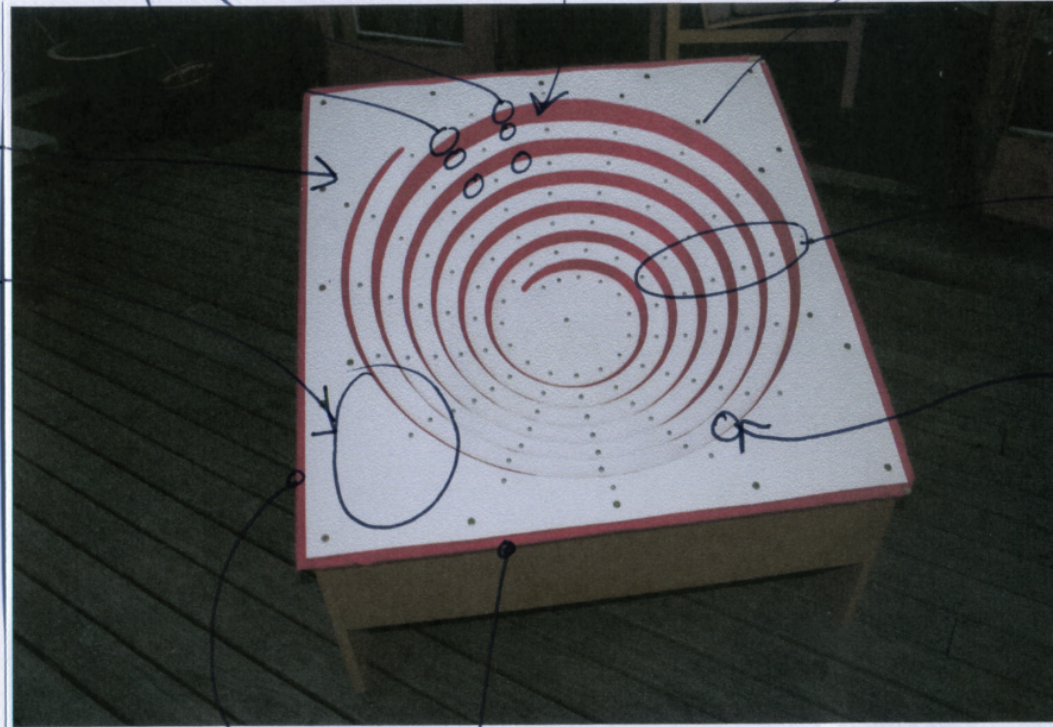

Visually too large → not interesting.

Seating allows people to sit in a few positions → but it is not overly dynamic.

appears to much like a Trubridge object.

## Problem:

The more spirals, the ~~less~~ more steps, the less severe ridges, the greater the comfort. → However, this makes the material more flexible. (weaker) perhaps metal would be better than plastic?

current idea requires a flexible fabric → then in an outdoor situation there may be issues about keeping it dry? → or is this moot given the design Art niche?

Dowels on 4 edges

9 April 2010 © Jason Klenner.

# Prototype One: Critical Reflection

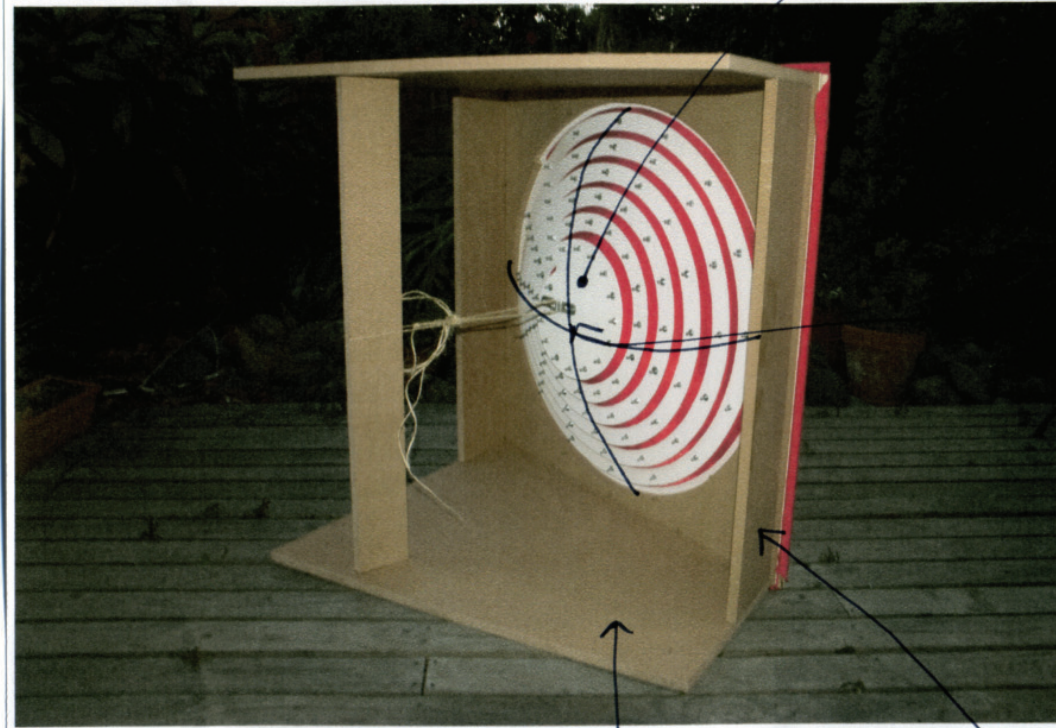

Surface is too rigid for seating.

Cavity is created/tensioned by a piece of string/rope.

Chair sides

Chair front

9 April 2010 © Jason Klenner.

# Prototype One: Critical Reflection

## Cons:

1. The use of lycra. would this limit its function?
2. size of frame.
3. Allows only a few seating positions
4. Not terribly unique. (from a distance)
5. Too many screws
6. Sharp seating edges visually and physically compromises comfort.
7. Materials. Plastic and lycra = premium?



8. Lycra. makes the shape solid in comparison with early scale models that was hollow. → It has lost that spacious/floating quality.

## Pros:

1. Spring/tension of lycra.
2. Size of cavity.
3. Contrast colour.
4. Size of planar surface.
5. Overall simplicity of spiral idea.
6. Ambiguous — indoor or outdoor specific.
7. Opportunity for future derivatives.

9 April 2010 © Jason Klenner.

Further thinking

Chair: Lounging / relaxing  
Chair. Sculptural. Indoor  
or Outdoor. Situations.

Design art →  
The object has to  
have an attribute  
of function → "Seating" is  
the function of a chair → the  
only function I am concerned about.  
Story is based around  
Casual, informal and flexible.

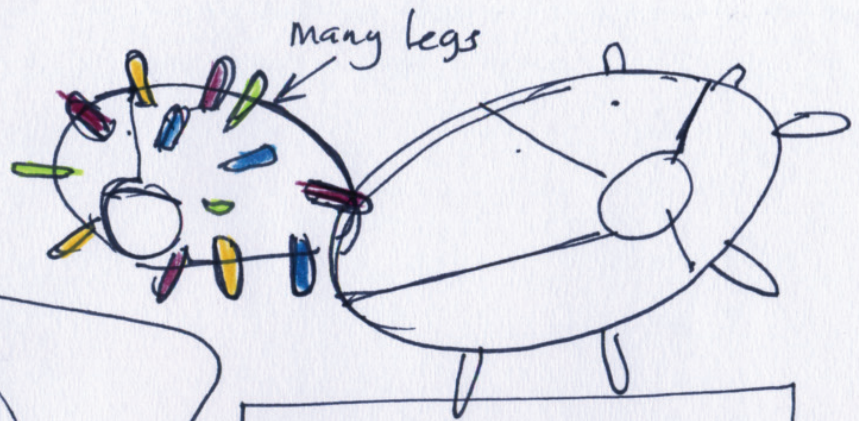

Dome form felt  
good → although  
it only provided  
a few seating positions

Carpet  
over a  
frame?

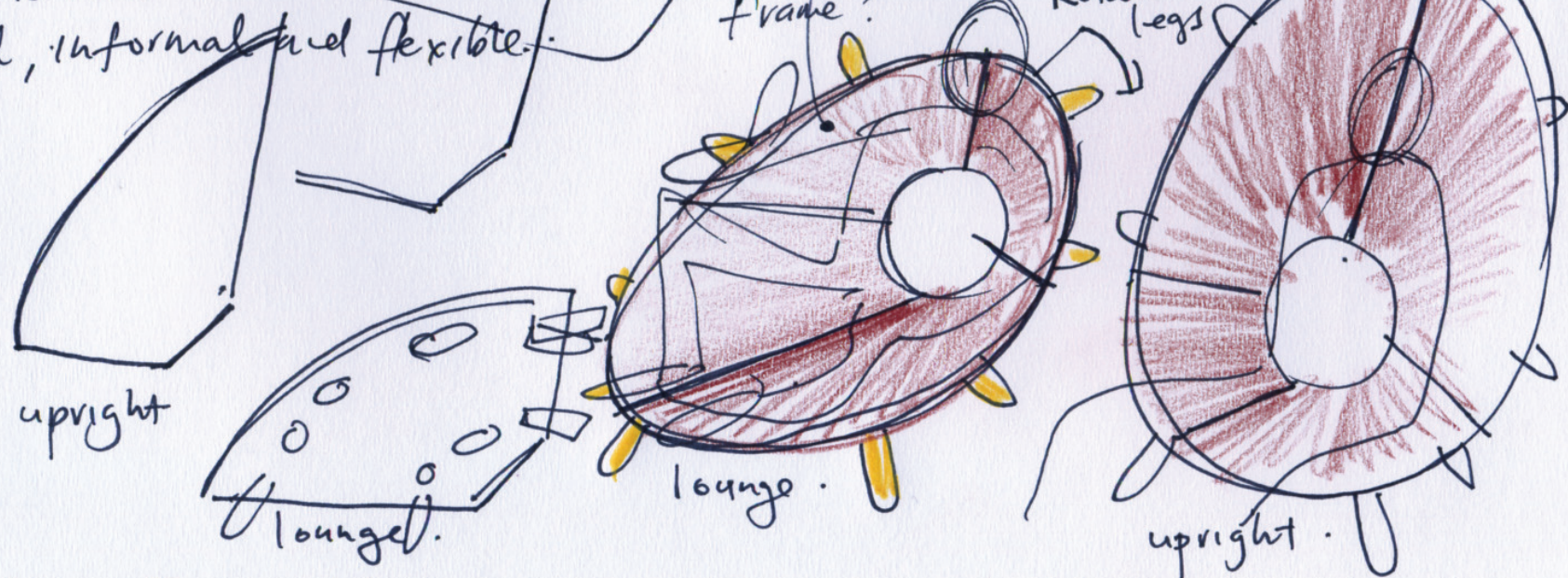

12 April 2010 © Jason Klenner.

# Post Prototype One: Thinking

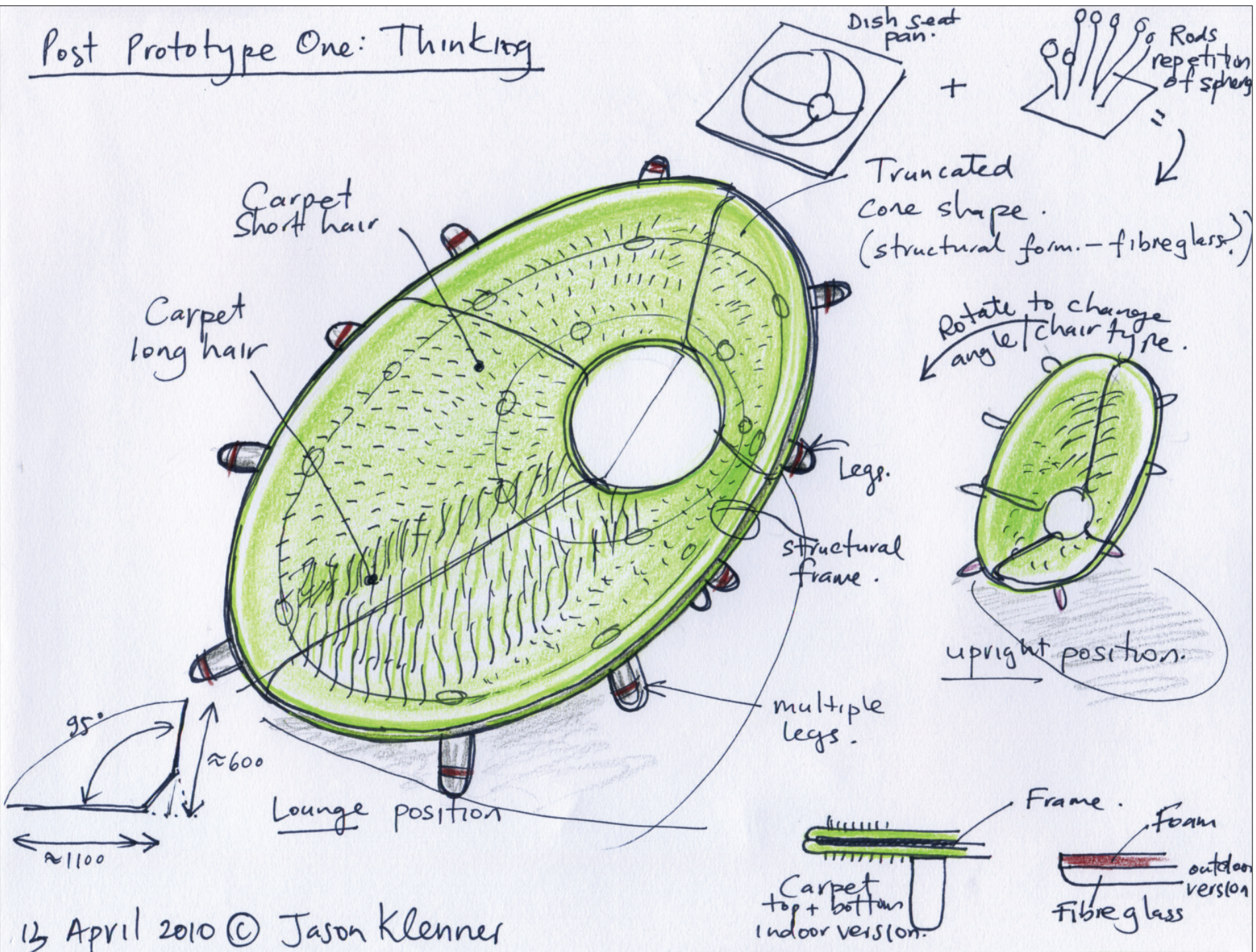

13 April 2010 © Jason Klenner



Post Prototype One: Thinking

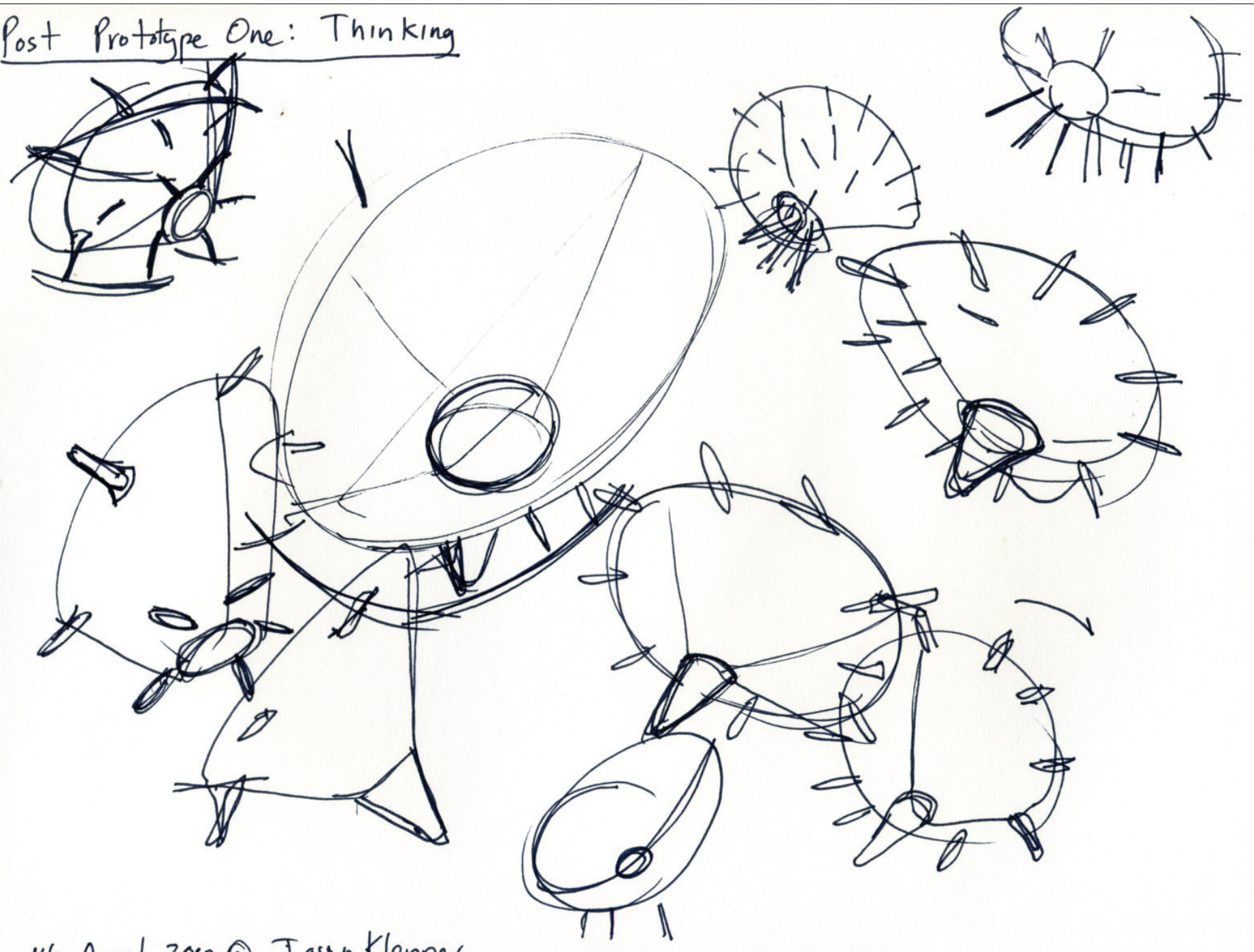

14 April 2010 © Jason Klenner

Post Prototype One: Thinking

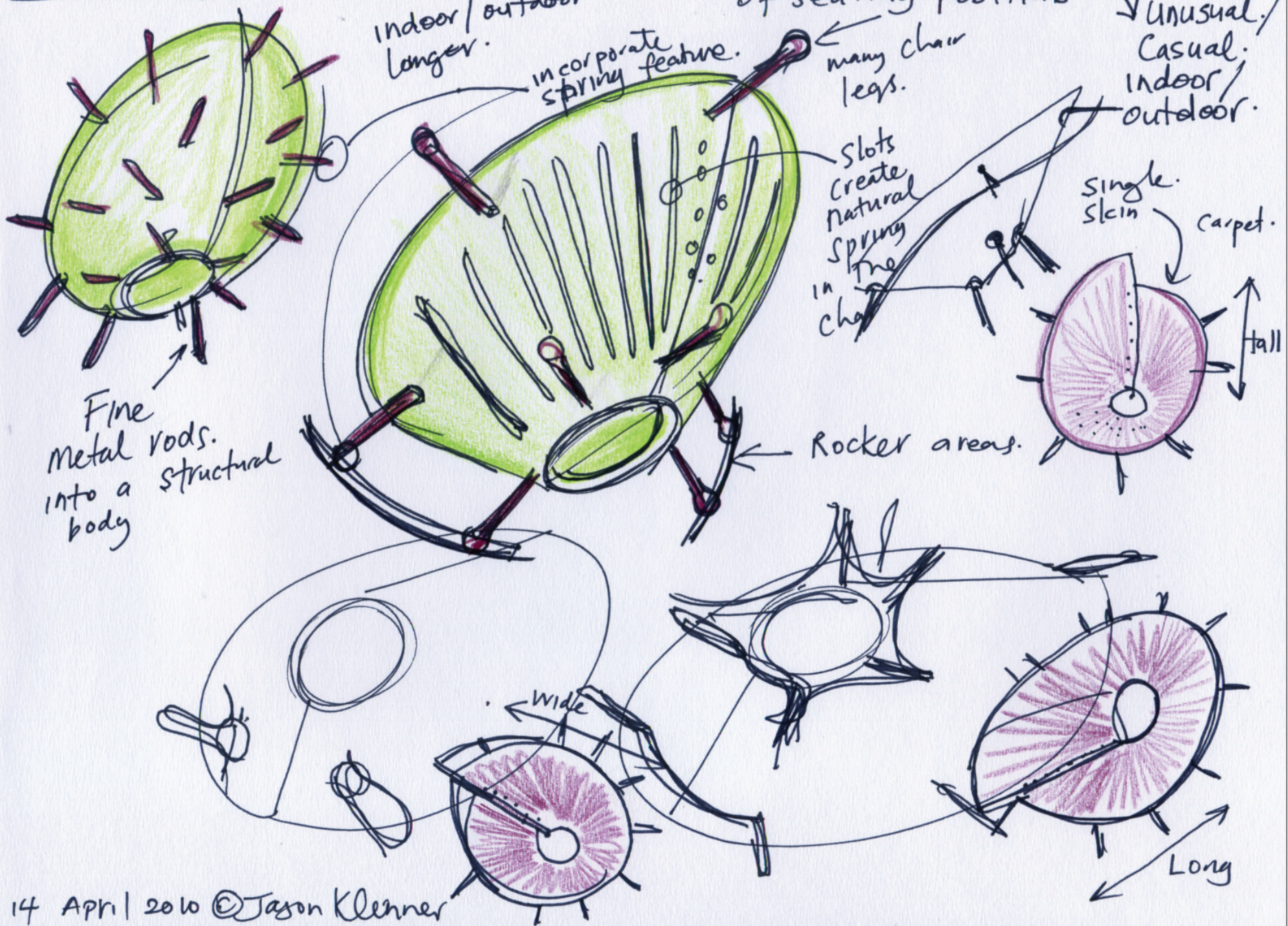

14 April 2010 © Jason Kleener

# Post Prototype One: Thinking

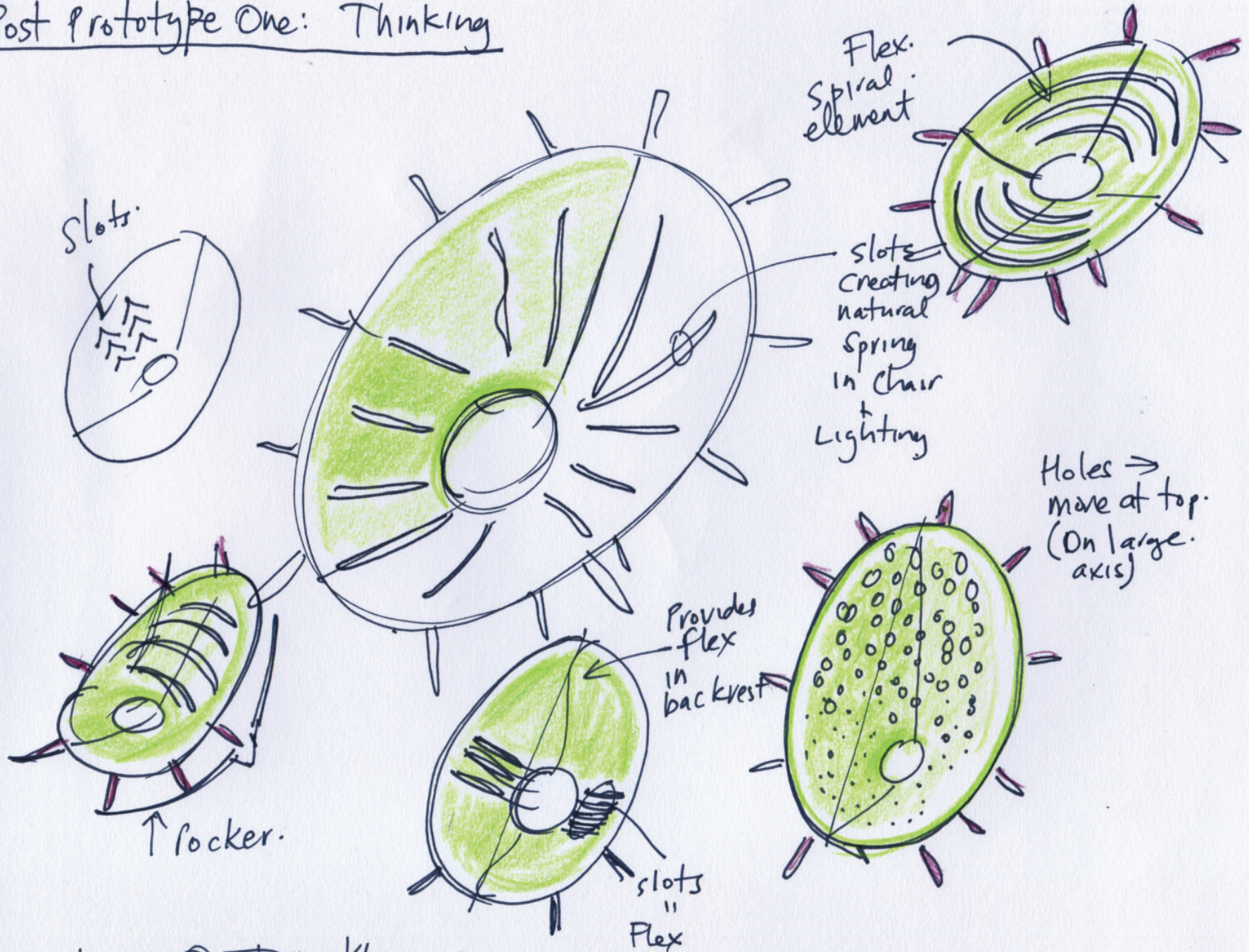

14 April 2010 © Jason Klenner

# SKYPE SESSION WITH MARK AND TONY

Mark - email him through the lycra chair



→ 2 dimensional fabric →

composite → flex and structural materials

→ Body goes numb →

→ semi rigid supports  
where support is required

bungy cord  
around a  
ring + a cone →

sticks  
for old  
days →

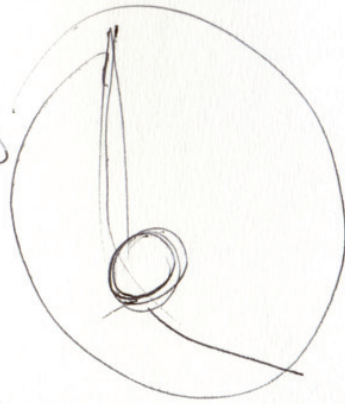

→ 1960s → 2 triangular  
frames →

rocking →

contraption  
too complicated

19 April 2010 © Jason Klenner

# POST SKYPE THINKING

Investigate material with one-directional flex to see what benefits this would provide

Check to see if the lycra chair has been done before in a similar way - 1960s triangular thing.

Having a structure spiral within the lycra chair is good as it provides support for legs backside → providing preventing hump bum that you get from fabric seats.

For the lycra chair → investigate flexible and structural materials combined to achieve a semiflex effect.

mark mentions for the backrest → Tony mentions for the seat pan. (composites)

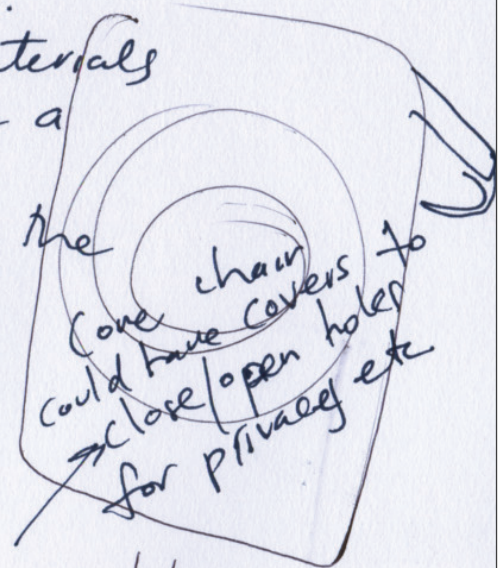

Looks like

art → could be hung on the wall when not used.

Don't try and make the objects too complicated / full of functions. → classics are so simple. eg. leCorbusiers Chaise Lounge.

instead of legs (many legs) The cone chair could sit inside a ring and thrust to achieve a greater number of positions.

20 April 2010 © Jason Kleuser

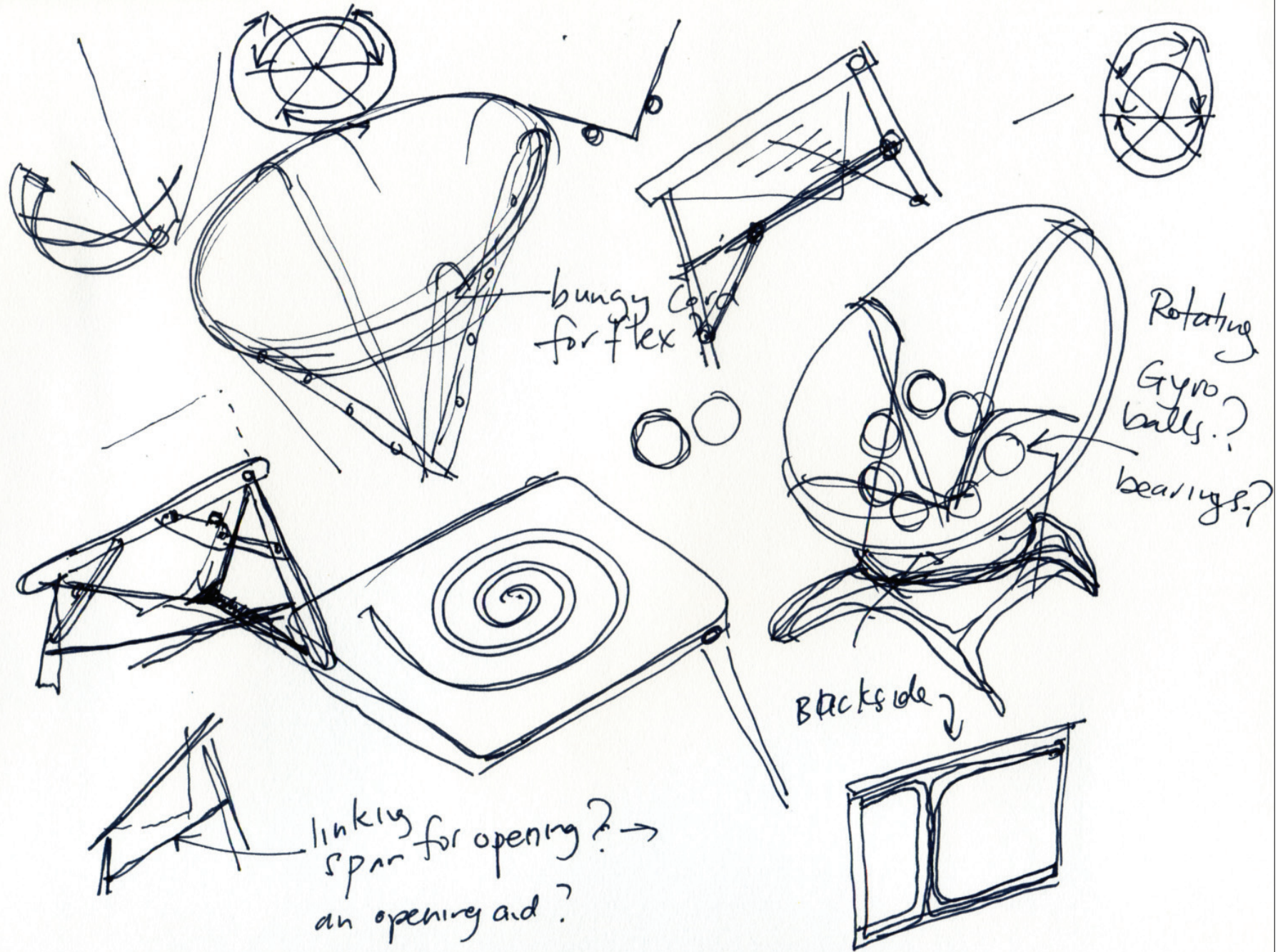

20 April 2010 © Jason Klenner

# POST SKYPE THINKING

Investigate material with one-directional flex to see what benefits this would provide

Check to see if the lycra chair has been done before in a similar way - 1960s triangular thing.

Having a structure spiral within the lycra chair is good as it provides support for legs backside → providing preventing hump bum that you get from fabric seats.

Feedback/Comments

For the lycra chair → investigate flexible and structural materials combined to achieve a semiflex effect.

mark mentions for the backrest → Tony mentions for the seat pan. (composites)

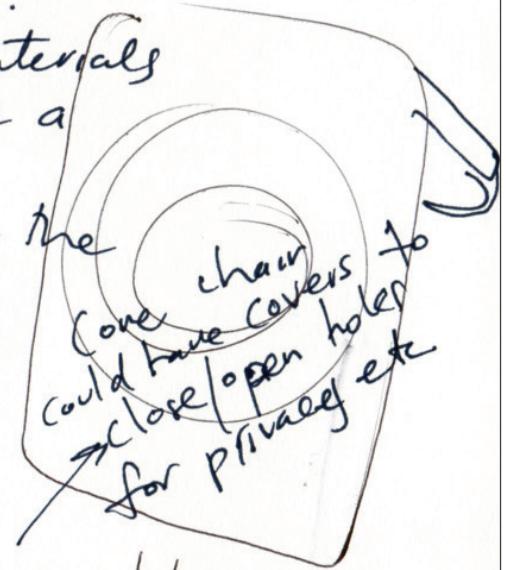

Looks like  
art → could be hung on the wall when not used.  
Art chair?

Don't try and make the objects too complicated/full of functions. → classics are so simple. eg. leCorbusiers Chaise Lounge.

instead of legs (many legs) the cone chair could sit inside a ring and twist to achieve a greater number of positions.

20 April 2010 © Jason Kleuser

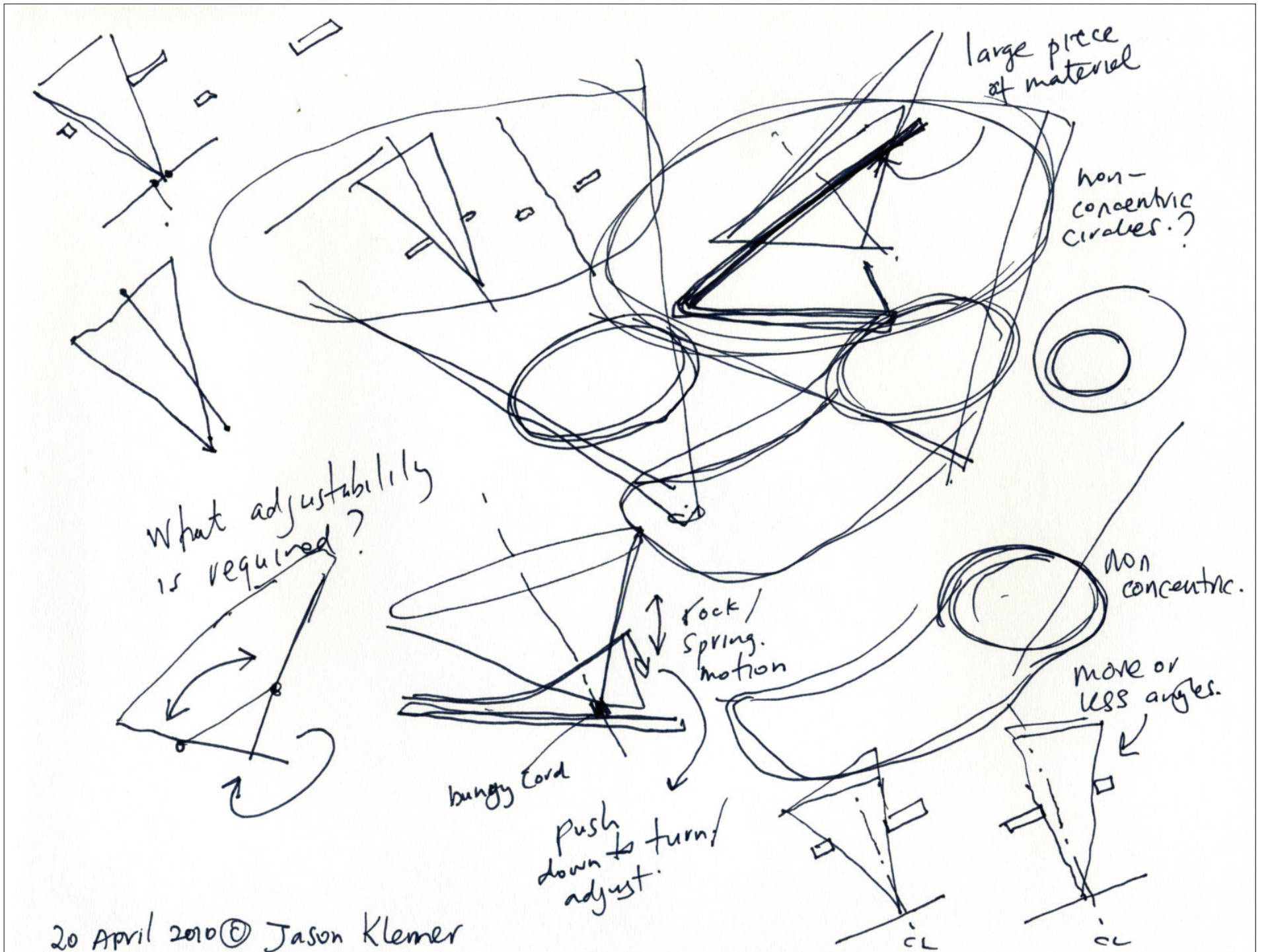

20 April 2010 © Jason Klemmer

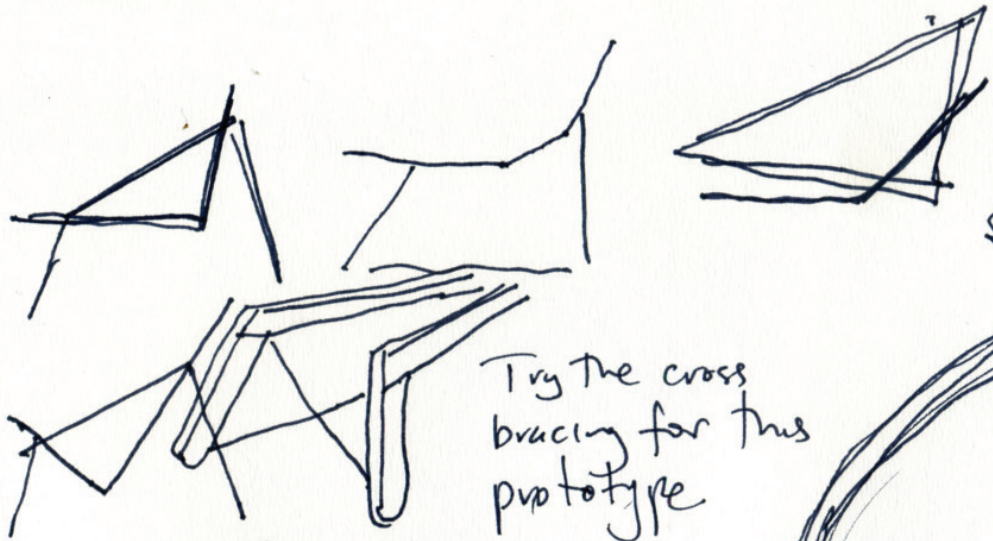

No legs at all?  
structural bean bag

Try the cross  
bracing for this  
prototype

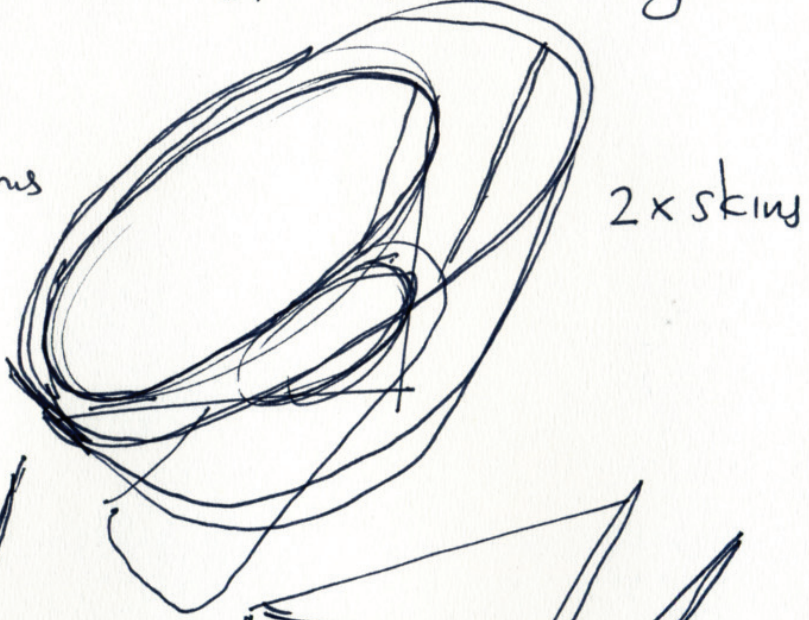

2 x skins

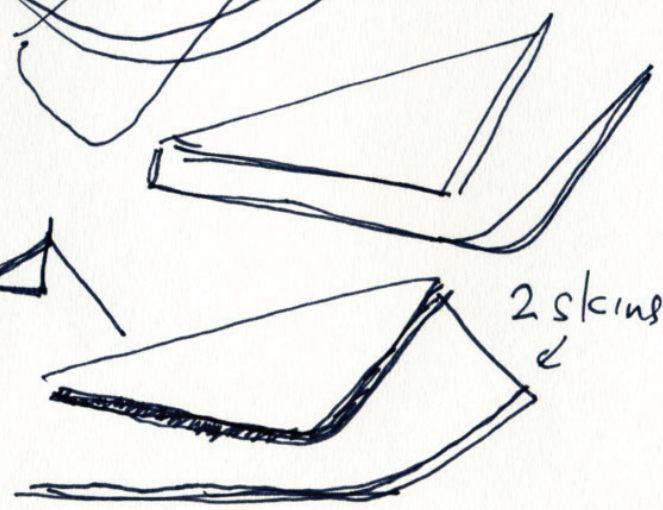
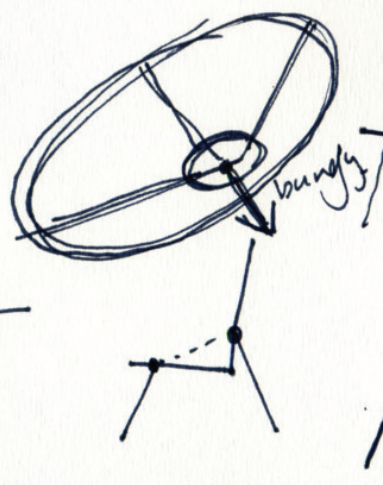
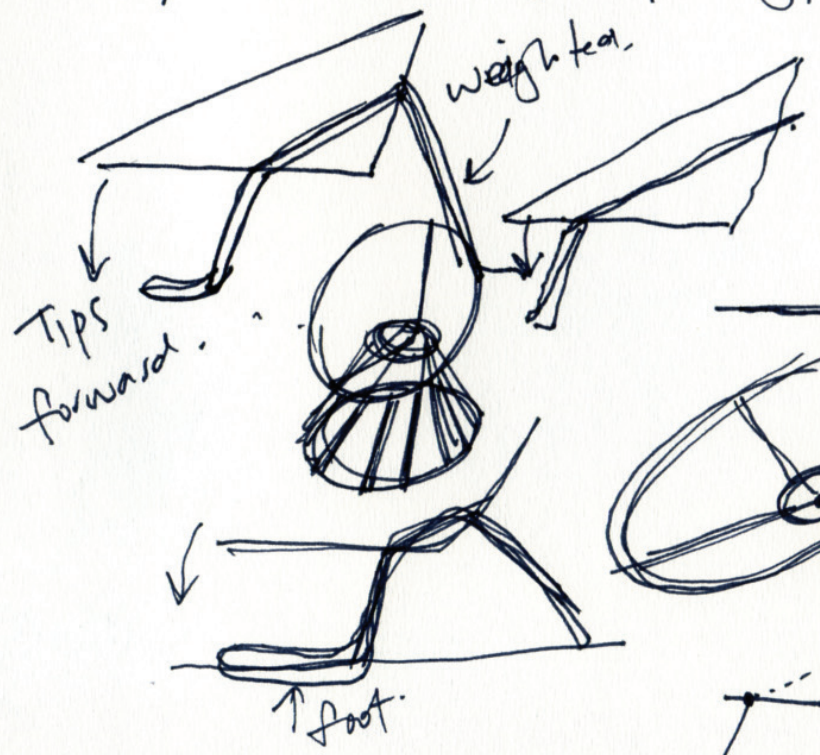

2 skins

21 April 2010 © Jason Klenner

Base materials?  
Separate legs?  
Solid?  
tube?

Non tip

This is good  
as it is always  
in the same relative  
position from to  
front edge

Non  
tip

Concentric rings allow the  
legs to be in the correct supporting  
position when rotating

Further  
Cone

hands

Random

21 April 2010 © Jason Klennar

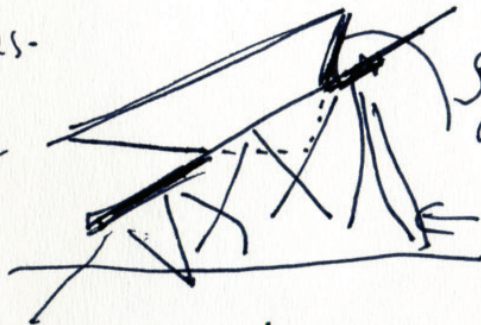
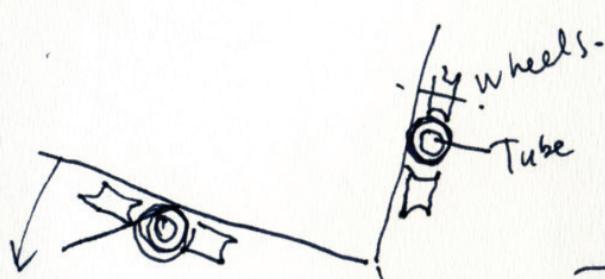
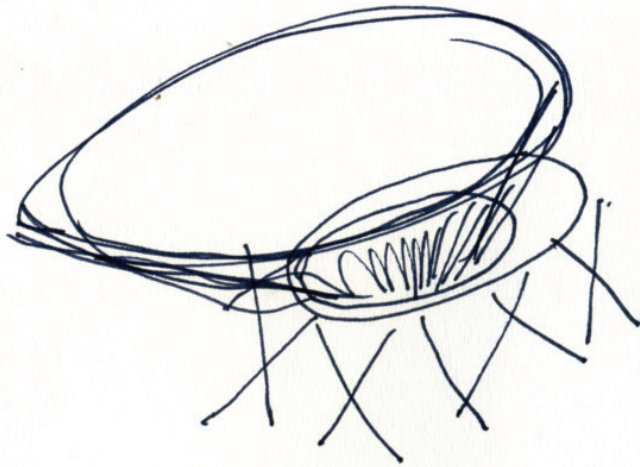

Smaller disk?

legs vandom + colour

Note.  
This runner  
system  
does not run  
on the same  
axis.  
force  
(bungs)

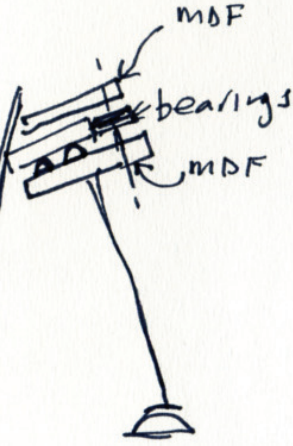
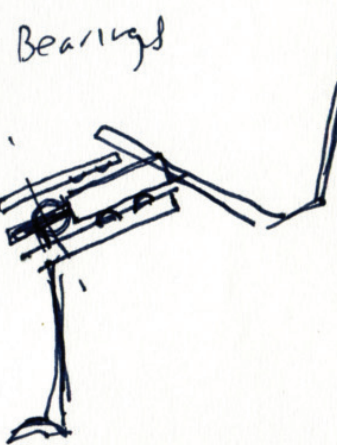

21 April 2010 © Jason Klenner





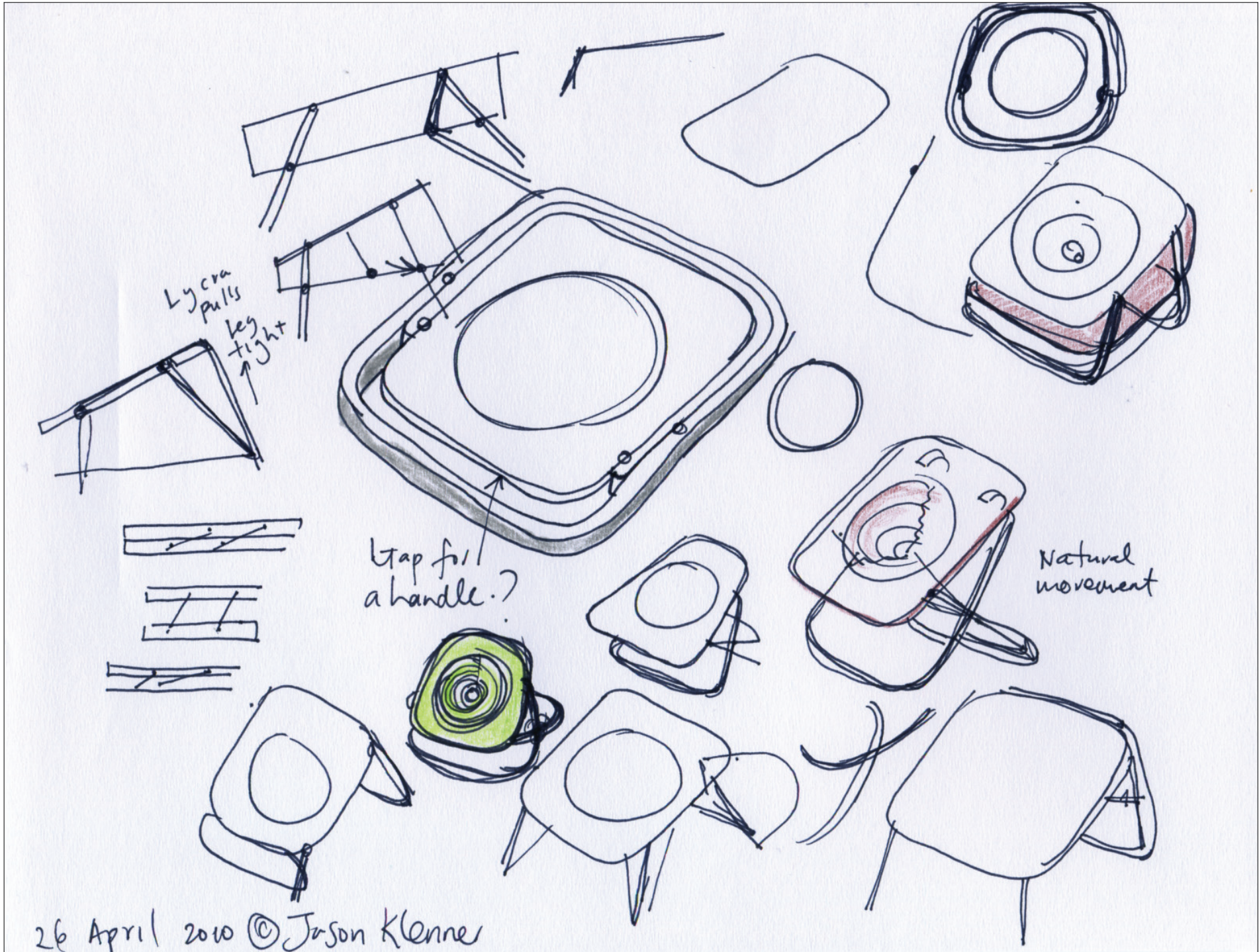

26 April 2010 © Jason Klenner

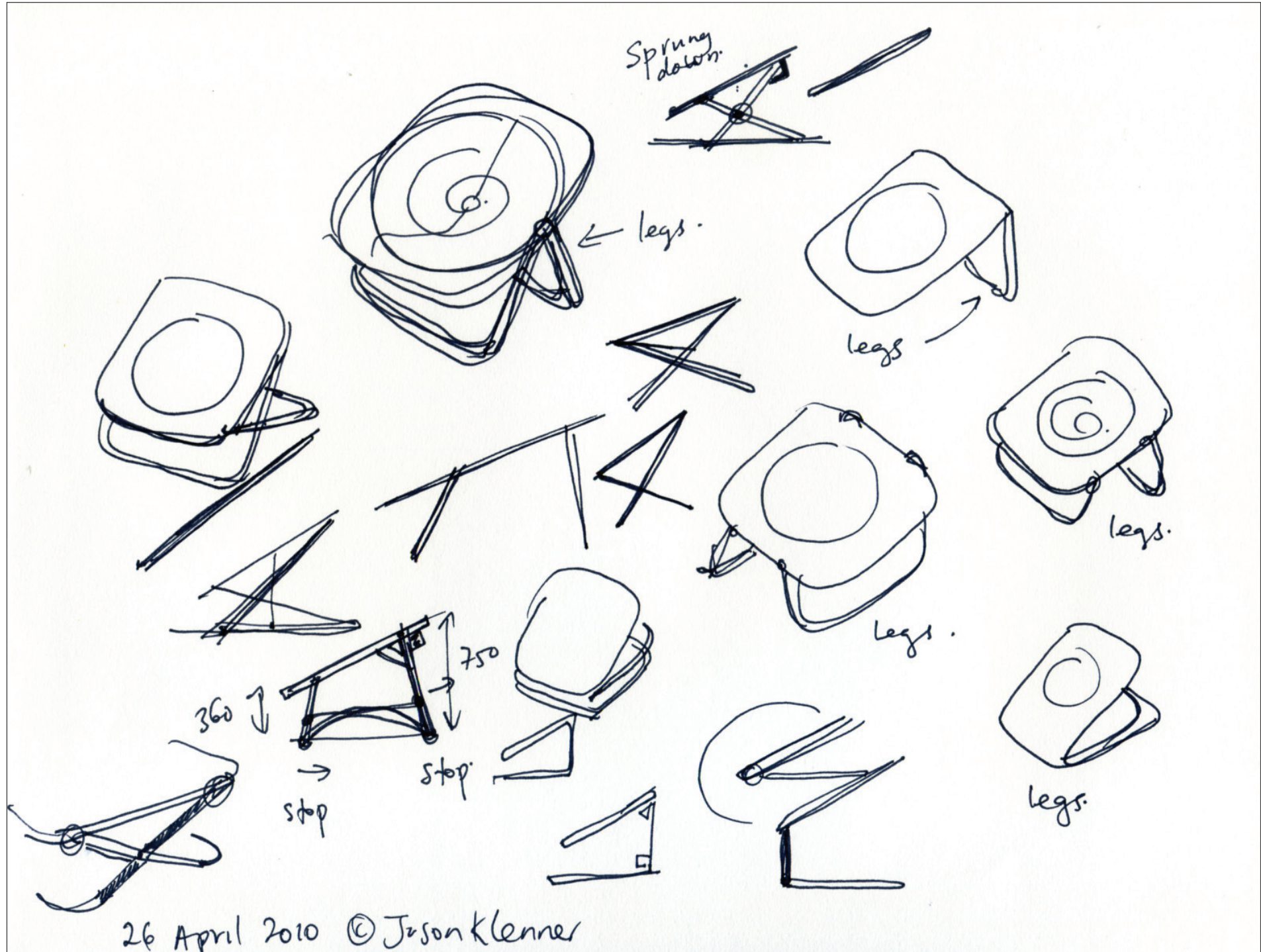

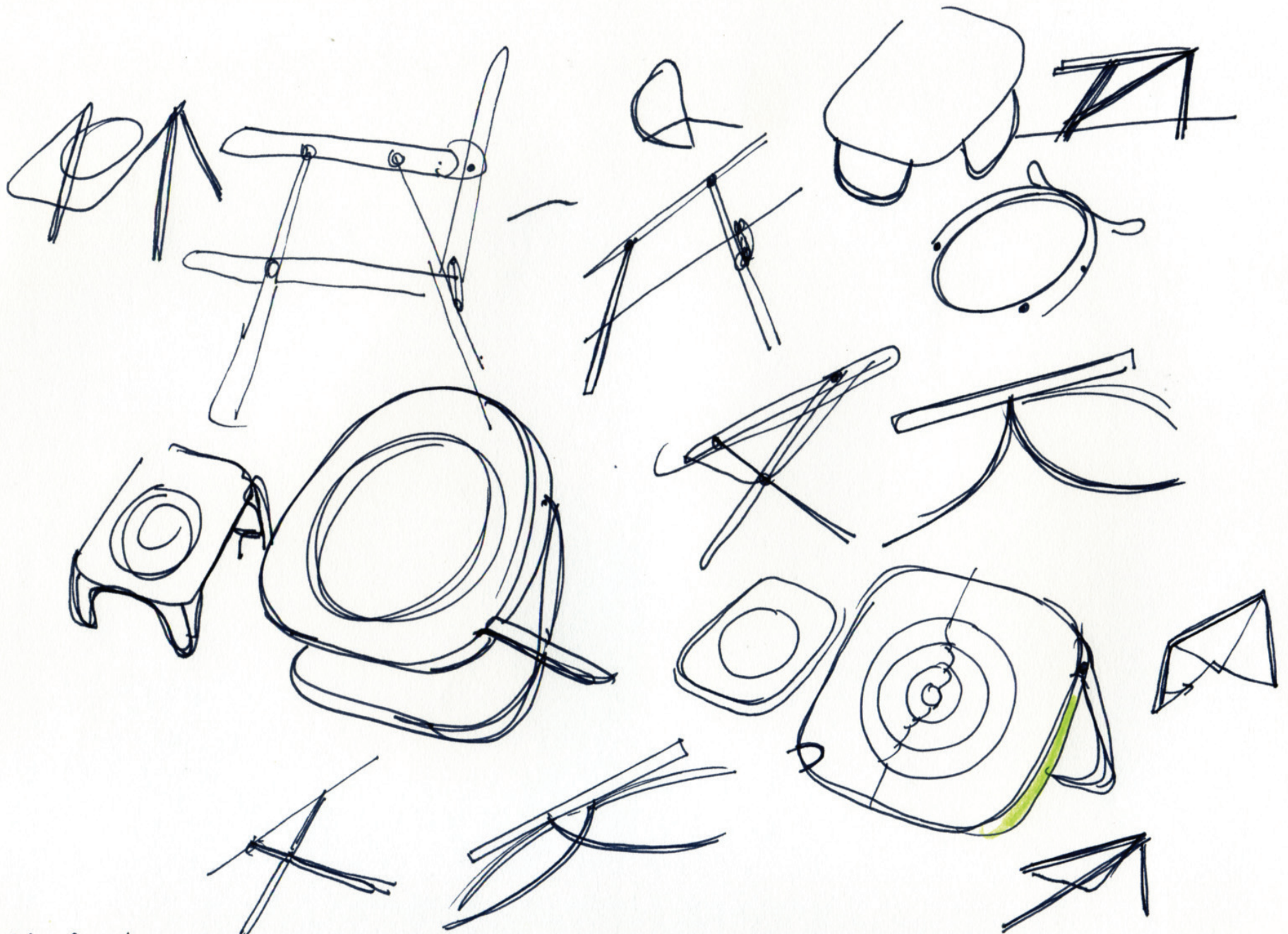

26 April 2010 © Jason Klenner

## Preparation for Crit Session 2.

Following Crit Session one. I concluded that there was a mismatch between the high level concepts generated and the area niche that I wanted to pursue.

In summary, the ideas generated appeared to be concepts generated that ~~were removed~~ did not consider materials and processes to achieve a point of difference and/or a level of personalisation.

note:  
I do have a style.

In order to understand this mismatch I further ~~researched~~ <sup>The meaning of</sup> Design Art and identified ~~examples~~ products to be used as examples.

XYZ describes Design Art as "... " Growing market too

Given this description, I have identified the following 3 pieces as reference points ~~for my~~ that I will use during development and evaluation phases.

26 April 2010 © Jason Klenner.

1. Pieces  
2. "  
3. "

All of these pieces. <sup>The</sup> use of materials is key ~~to~~ ~~the~~ success and ~~include~~ ~~or~~ incorporate processes. That ~~are~~ have an element of being worked by hand; not necessary by a production machine.

~~Comparing this~~ By using these findings to evaluate the high level concepts generated, I realised that these ~~have been generated through the eyes of a commercial mass-market designer, not a designer~~

generally key  
are interesting starting points, but do not ~~take~~ ~~explore~~ incorporate the use of materials in a interesting way to add functionality or increase desirability.

In conclusion, they ~~have~~ are tight and appear to have been generated through the eyes of a 'commercially' orientated designer, not a designer of items for limited edition or exhibition purposes.

26 April 2010 © Jason Klenner

In order to resolve this mismatch, I have focused  
on: ~~working at scale 1:1 at a full-size scale and incorporating~~  
~~materials that~~ → "and the experience of seating"

- > developing a chair as the first product in my range.  
The remaining 2 products will be smaller. Complementary products.
- > Working at scale 1:1, using the natural properties of materials  
in new ways
- > Using the lifestyle associated with New Zealand as a basis for my design  
my interpretation of the indoor and outdoor.

Combined, these elements will result in a design signature.  
So my earlier explanation of Quiky or light-hearted no  
are not necessarily valid any longer.

26 April 2010 © Jason Klemes

# Turning The spiral chair into a deck/folding chair

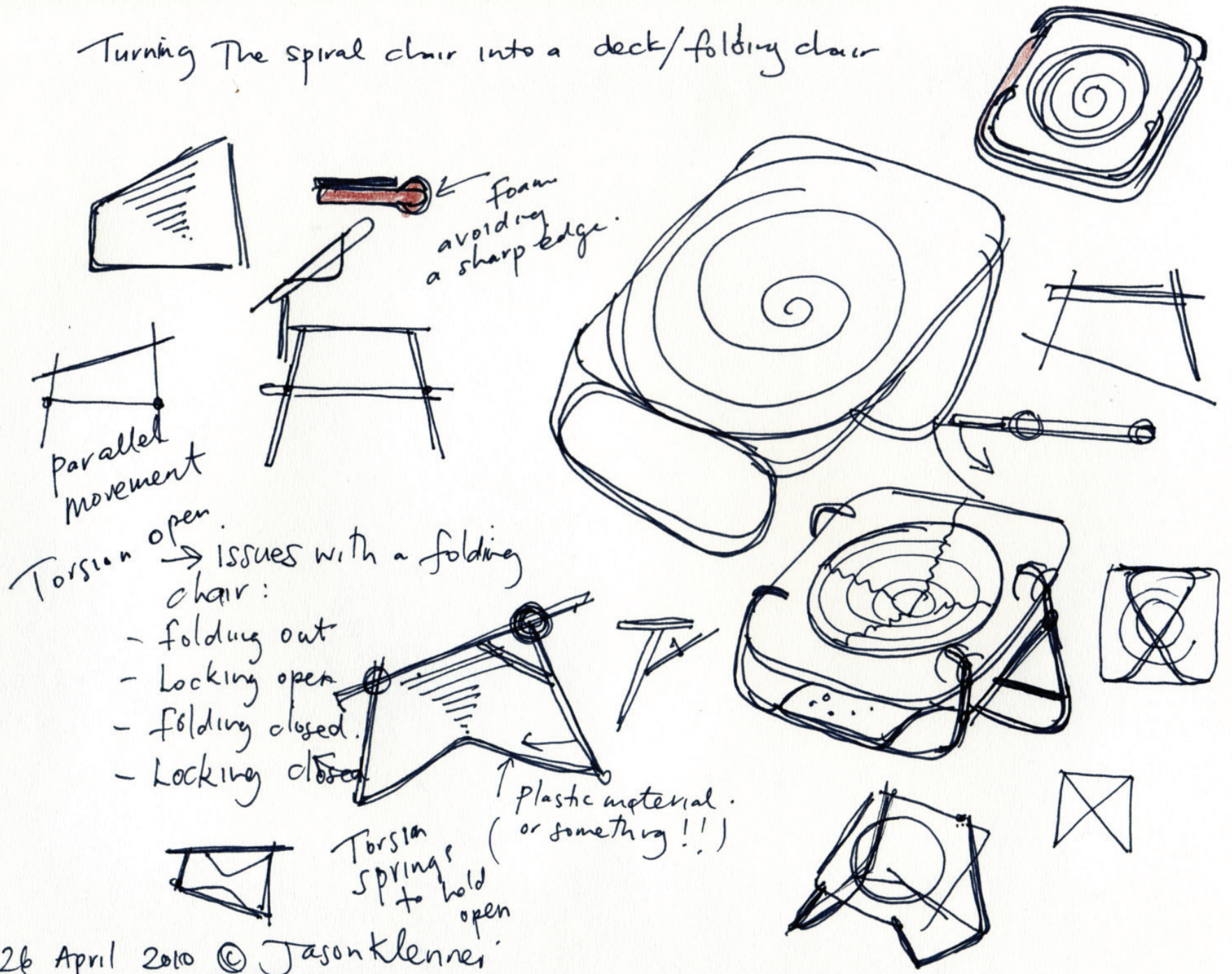

26 April 2010 © Jason Klenner



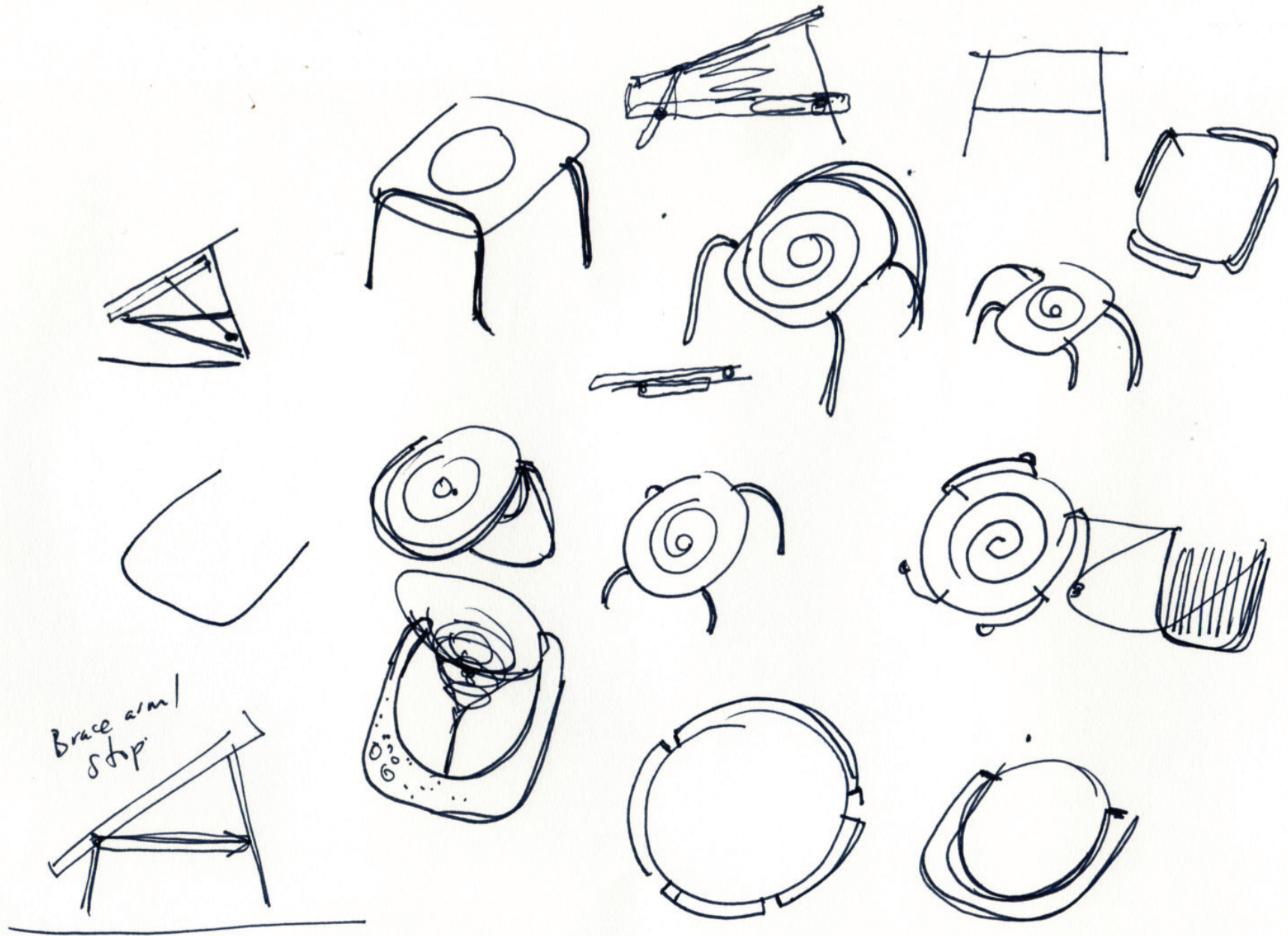

26 April 2010 © Jason Klemmer





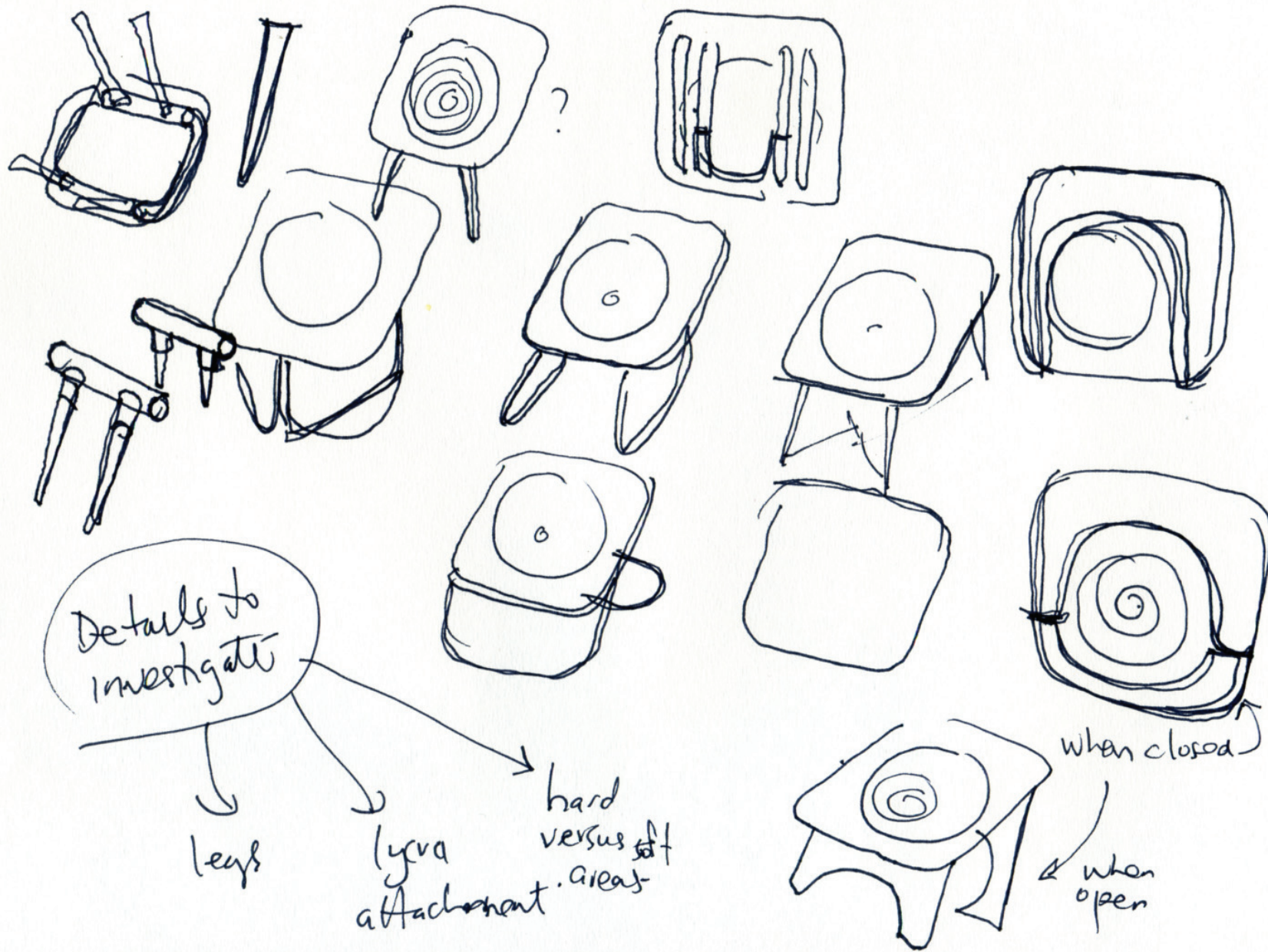

28 April 2010 © Jason Klenner

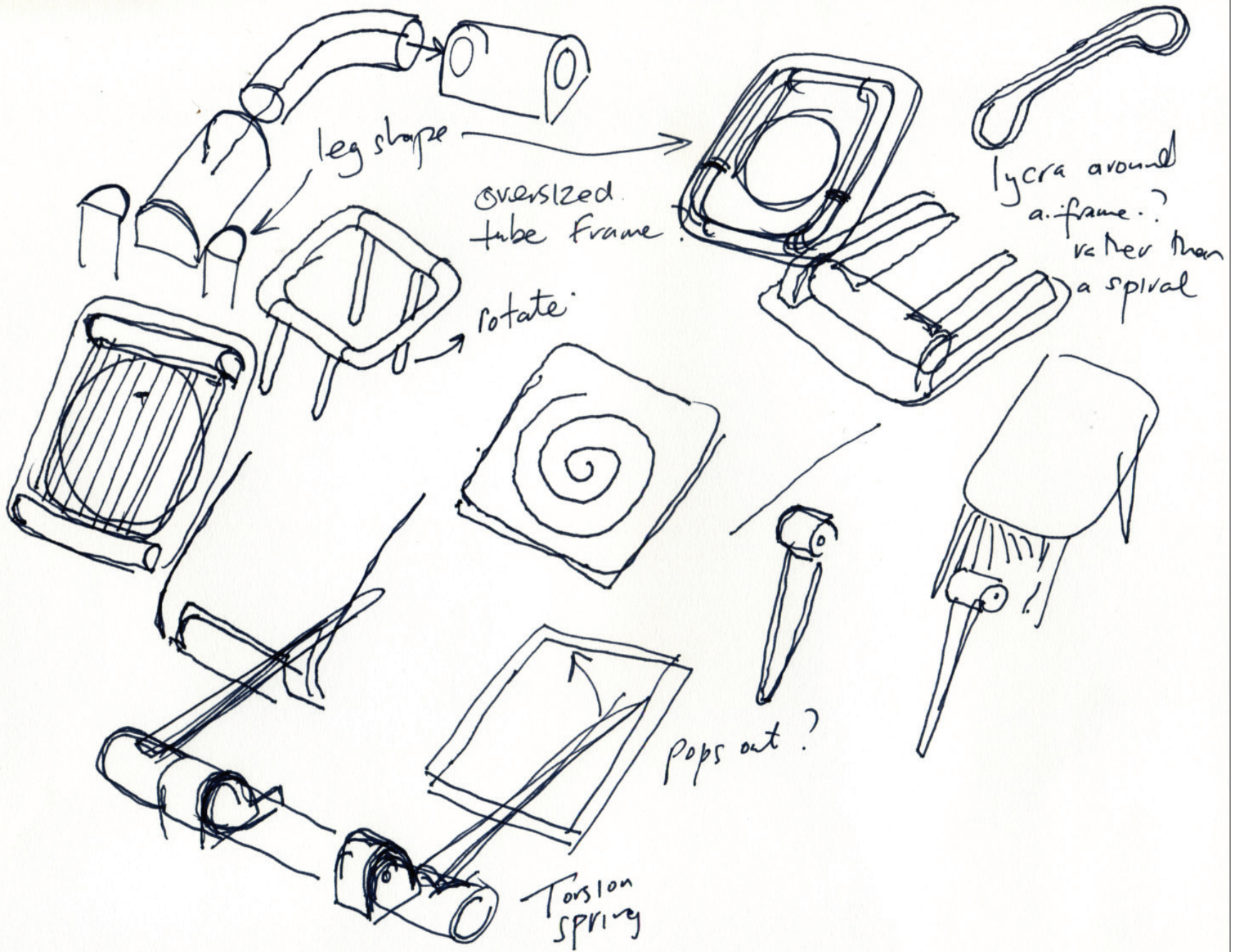

28 April 2010 © Jason Klenner

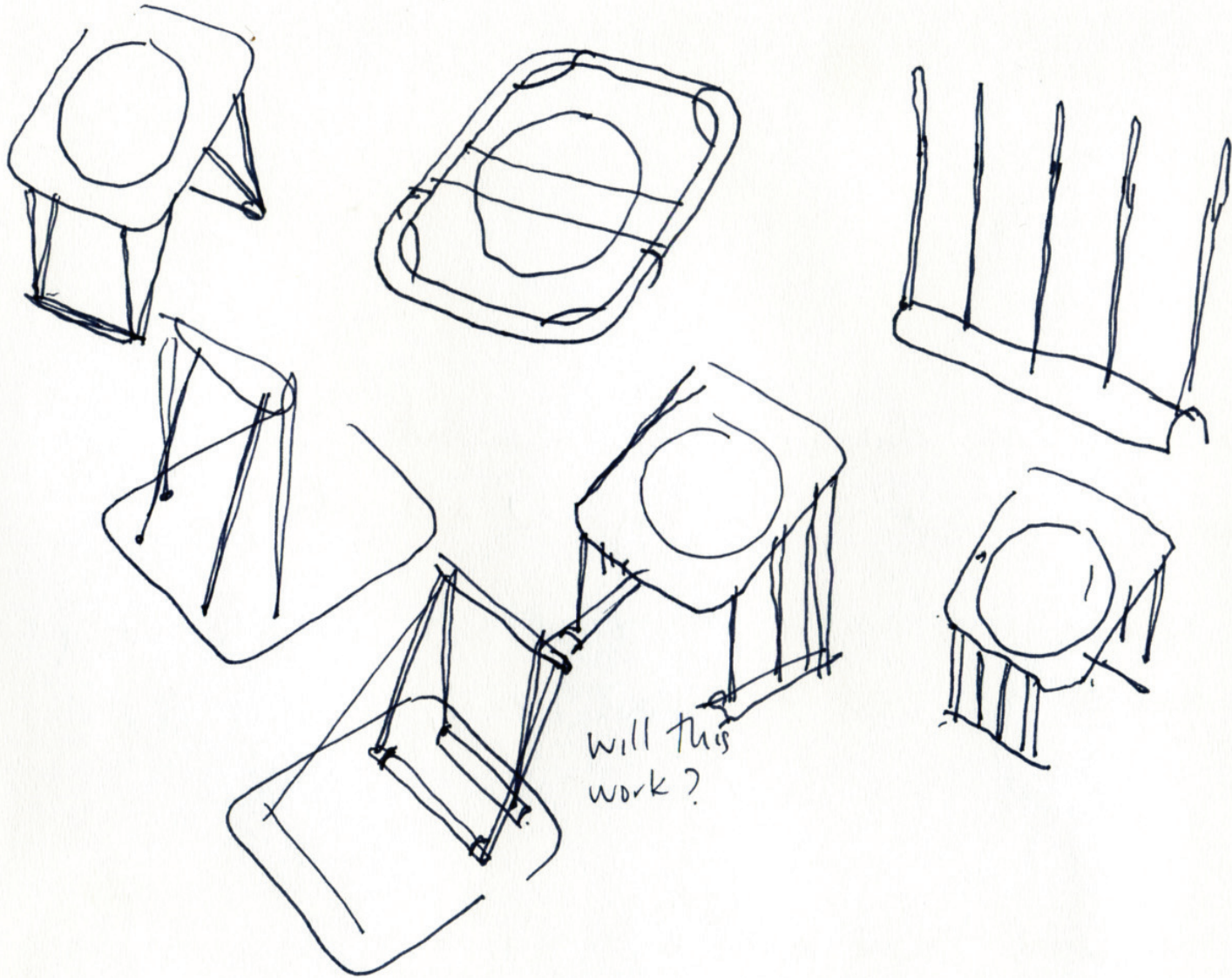

© Jason Klenner 28 April 2010

PROTOTYPE TWO: CRITICAL REFLECTION

The structure is very large → too large for a regular domestic situation and it is difficult to adjust the seating positions.

Note: Although it is probably not much larger than Le Corbusier's Chaise Longue. (TBC)



Too large?? Too small??

Rotating truncated cone is a clever idea → great for lounging / multi-positional seating.

corrugations

outline is visually interesting → But very large.

SEMI LOUNGE POSITION.

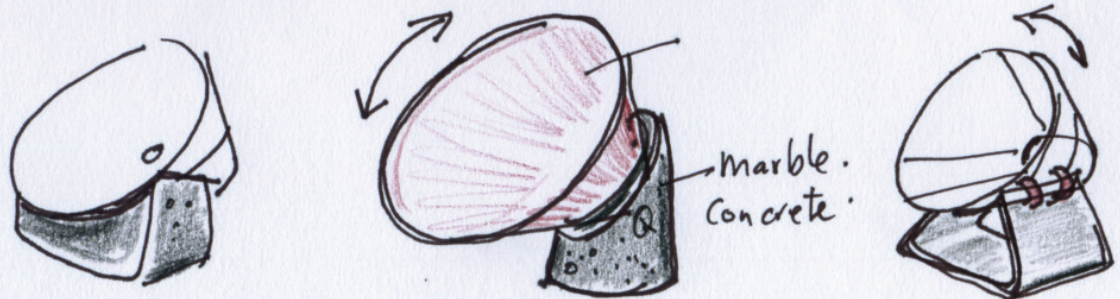

29 April 2010 © Jason Klenner

# PROTOTYPE TWO: CRITICAL REFLECTION

PROOF OF PRINCIPLE MODEL ONLY!!

DESCRIPTION:  
A ROTATING SEAT THAT  
ALLOWS UPRIGHT LOUNGING  
AND LAID BACK LOUNGING →  
FOR INDOOR AND OUTDOOR  
ENVIRONMENTS

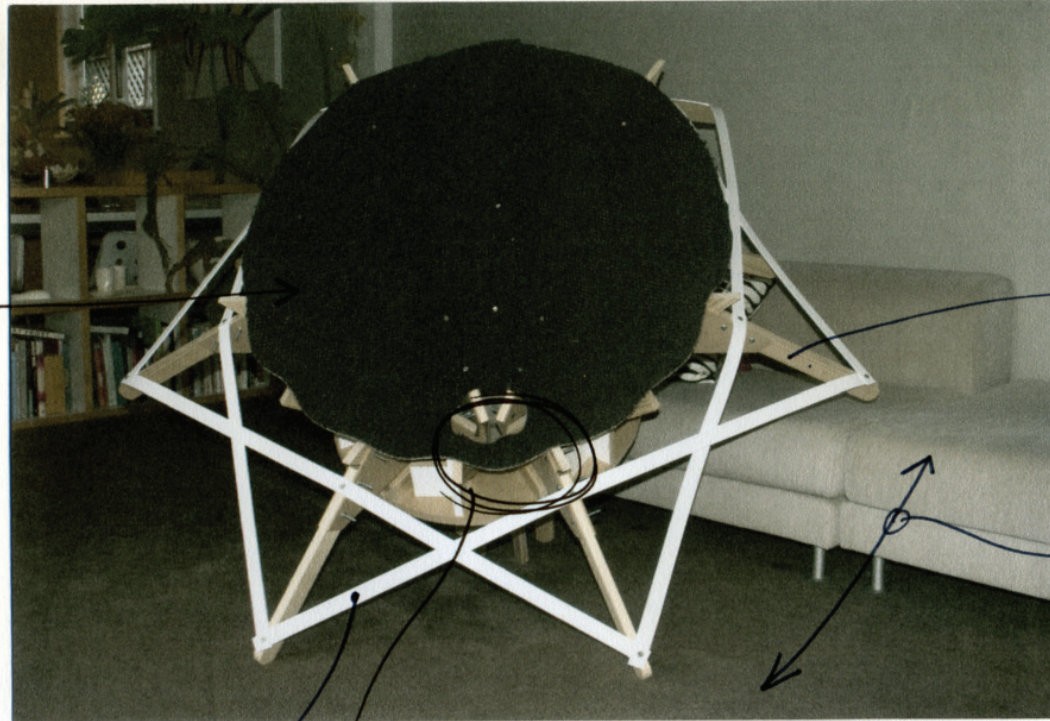

Carpet is used  
to create the  
seat pan and  
back rest.

This is not  
stiff enough or  
structural.  
Resulting in a  
weak and  
uncomfortable.  
seat support

Prototype has  
9 legs in  
total.

CHAIR.  
ROTATES

UPRIGHT - CHAIR ORIENTATION

TOO MUCH STRUCTURE!!

These spans would not  
be on a final design →  
They are currently used  
to strengthen the model.

Subtle corrugations appear interesting  
and provide subtle ridges for feet/  
legs and arms.

29 April 2010 © Jason Klenner