

Copyright is owned by the Author of the thesis. Permission is given for a copy to be downloaded by an individual for the purpose of research and private study only. The thesis may not be reproduced elsewhere without the permission of the Author.

Development of a Headrig Process Information System

**A thesis presented in partial fulfilment of
the requirements for the degree of**

Masters of Technology

In

Computer Systems Engineering

**at Massey University, Palmerston North,
New Zealand.**

Peter Bayne

1999

Abstract

A computer-based process information system was developed to gather operational information about the headrig bandsaw at the Timber Technology Centre (TiTC) sawmill in the Waiariki Institute of Technology, store the data in a database, and display the information in various forms to the user.

The project was the first part of an encompassing programme to instrument an entire commercial sawmill. This research programme aims to determine which variables are crucial to quantifying the sawing processes and to investigate the best techniques for measuring the variables.

The system developed was extremely modular. Both analysis modules and sensor hardware can be added or removed without any need for restarting the system. A client-server architecture using networking communications was used to facilitate this. A central server gathers and stores the data, and individual clients analyse the data and display the information to the user. This enables analysis modules to be added and removed without even restarting the system.

An experiment to determine the effect of wood density on the variables measured was used to test the viability of the completed system. The system successfully gathered all of the information required for the experiment and performed 70% of the data collation and analysis automatically. The remainder was performed using spreadsheets as this was deemed to be the most suitable method.

The loosely coupled design of the system allows it to be up-scaled to a mill-wide program easily. Experiments performed to gather information about pivotal process variables are currently being planned, and should be underway as the expansion into other machine stations is being designed.

Acknowledgements

I would like to acknowledge all the parties that were involved in the development of this project. In particular Tom O'Toole, Steve Hemsley, Bill Dalzell, and Margriet Theron at the Waiariki Institute of Technology, and Ian Hogg and Norm Agnew at Jaymor Industries Ltd, for their part in pulling all this together.

Contents

1. Introduction	1
1.1 Application of Technology to Sawmilling	2
1.2 Traditional evaluation techniques	3
1.3 Factors determining performance	5
1.4 Outline of Thesis	8
2. Facility Requirements	10
2.1 Introduction	11
2.1.1 Current situation	11
2.1.2 Proposed situation	12
2.2 Functional Requirements	12
2.2.1 Business Requirements	13
2.2.2 Technical requirements	13
2.3 Chosen Facility	13
2.4 Application to headrig bandsaw	14
2.4.1 Current headrig station	15
2.4.2 Instrumented headrig station	16
2.4.3 Headrig specific requirements	17
2.5 Summary	18
2.6 References	18
3. Instrumentation	19
3.1 Equipment Selection	20
3.1.1 Log Feed Speed	20
3.1.2 Lateral Sawblade Movement	20
3.1.3 Vertical Bandwheel Movement	22
3.2 Data Capture Device	23
3.2.1 Wiring Structure	23
3.3 Calibration and Error Management	25
3.3.1 Electrical noise	25
3.3.2 Device Calibration	25

3.4	Summary	26
4.	<i>Software Design</i>	28
4.1	Introduction	29
4.2	Architecture	29
4.3	Data Flow	31
4.4	Server Software	34
4.4.1	Monitor	34
4.4.2	Link Manager	37
4.4.3	Object Structure	39
4.5	Client Software	41
4.5.1	Headrig Operator	42
4.5.2	Operating Envelope	43
4.5.3	Statistics Reporter	44
4.5.4	Production Manager	45
4.6	Summary	45
5.	<i>Experiment: Effect of Wood Density</i>	47
5.1	Introduction	48
5.2	Experiment Objectives	48
5.3	Methods and Materials	48
5.4	Results	50
5.4.1	Density	50
5.4.2	Cutting Patterns	50
5.4.3	Process Indicators	51
5.5	Discussion	52
5.5.1	Log-Based Effects	54
5.5.2	Cut Position Based Effects	55
5.6	Conclusions	56
6.	<i>System Evaluation</i>	58
6.1	Function	59
6.2	Reliability	60
6.3	Modularity	61

6.4	System Response	62
6.5	Conclusion	63
7.	Conclusion	65
7.1	Major Points	66
7.2	Future Directions	67

Figures

Figure 1-1:	Operating Envelope	6
Figure 2-1:	The headrig bandsaw at TiTC	14
Figure 2-2:	Logical Layout	15
Figure 2-3:	New Logical Layout	16
Figure 3-1:	Inductive Proximity Sensor	21
Figure 3-2:	Proximity Sensor Mounting	21
Figure 3-3:	Linear Variable Displacement Transducer	22
Figure 3-4:	LVDT mounting Position	22
Figure 3-5:	Wiring Diagram	24
Figure 3-6:	Proximity Sensor Calibration (12V supply)	26
Figure 3-7:	LVDT Calibration (12V supply)	26
Figure 4-1:	Architecture Context Diagram	30
Figure 4-2:	Data flow Diagram	32
Figure 4-3:	Expansion of the data flow through the TiTC Process Information System	33
Figure 4-4:	Monitor Program Structure	34
Figure 4-5:	Link Manager Structure	37
Figure 4-6:	Server Object Hierarchy	39
Figure 4-7:	Alternate Architectural Links: a) Direct "has a" relationship b) Separate thread via data structure	40
Figure 4-8:	Analysis & Display object hierarchy (Client-Side)	41
Figure 4-9:	Operator Display	42
Figure 4-10:	Operating Envelope Setup Dialog	43
Figure 4-11:	Operating Envelope	43
Figure 4-12:	Sample Statistics Report	44
Figure 4-13:	Report Generator Screen	45
Figure 5-1:	General cutting pattern	49
Figure 5-2:	Specific cutting patterns used	50
Figure 5-3:	Effect of density on lateral blade position	51

<i>Figure 5-4: Effect of density on top band wheel position</i>	52
<i>Figure 5-5: Example of 'spiking' - Log F, cut 2</i>	53
<i>Figure 5-6: Effect of density on 'spiking'</i>	53
<i>Figure 5-7: Adjusted effect of density on wheel position</i>	54
<i>Figure 5-8: Effect of density on blade movement</i>	54
<i>Figure 5-9: Effect of density on wheel movement</i>	55
<i>Figure 5-10: Blade Bias by Cut Number</i>	55
<i>Figure 5-11: Wheel Position by Cut Number</i>	56
<i>Figure 5-12: Wheel movement by cut number</i>	56
<i>Figure 6-1: Response Times</i>	62
<i>Figure 6-2: Response degradation due to client loading</i>	63
<i>Figure 7-1: Layout of other machine centres</i>	67

Tables

<i>Table 4-1: Event database table format</i>	35
<i>Table 4-2: Description of Monitor Initialisation file</i>	36
<i>Table 4-3: Packet Structure</i>	38
<i>Table 5-1: Log sizes and densities</i>	50
<i>Table 6-1: Functionality provided by system</i>	59

Development of a Headrig Process Information System

1. Introduction

1.1 Application of Technology to Sawmilling

The popular opinion among many in the forestry sector is that solid wood processing is a low technology industry. It is thought that it is simply a matter of cutting logs into pieces of suitable dimension, and then selling them. The focus is mainly on how many cubic metres of product can be produced in a given day, and what the raw material cost is, in order to increase the margins. This has led to a commodity market for timber, where it is sold largely by volume.

The result is a low margin industry with a belief that investment in new technology, which claims to improve the quality of their process, is not feasible. This belief has been perpetuated through the use of machinery that is decades old in many of New Zealand's sawmills, some of which have shown sustained successful operation. Many prefer the older machines and techniques because they can understand them, and know what to do when they fail in any way. An example of this is the overseas research into thinner sawblades, which can reduce the amount of fibre lost to sawdust. Commercial trials of this technology in New Zealand have had mixed results because of the level of control of the process required to use it. Thinner blades need more precise maintenance and have a tighter envelope of operation to be successful (Beauregard, 1995). Figures on the sensitivity of the technology to varying New Zealand practices would help sawmillers to make the decision whether to use it.

Higgs (Higgs, 1989) stated in a keynote address "*There are three basic barriers to the adoption of today's saw technology: fear of the cost, fear of the cost, and fear of the cost. Horror stories abound regarding:*

1. *Initial costs in adopting new technology*
2. *Costs in operating and maintaining a 'sensitive' technology*
3. *The cost to egos and careers, 'bruised' by saw program failures*

What often goes unheralded, however, are the profits a successful sawmill can garner through technological adaptation. Competition tends to hush success."

The fact that there is any investment at all in modern technology shows that at least some of the industry would like to make higher value products, but many have expressed views that upgrading is too hard. Edlin (Edlin, 1994) stated that

“The big constraint is the old problem of capital investment, and shifting production towards more refined products with less product volatility”. Some of the complaints directed at new technology are that the new machines and techniques are too fussy and include a range of hidden costs. This seems to be due to the high level of refinement of these technologies in order to produce high quality products overseas, but which have to be altered to perform in New Zealand. An example of this is the typical North American log handling apparatus installed in New Zealand. The typical New Zealand *Pinus Radiata* log is both bigger in diameter and denser than the typical North American hardwood log that most of these systems are designed for. When installed in New Zealand without modification they have been known to either break within weeks of installation due to the excess loading or are unable to hold the logs in the correct position throughout processing (Labeda, 1993). The high cost of altering an off-the-shelf product so that it still performs as well in NZ as in the country of origin can be prohibitive, and unexpected. This is also reflected in the comments that new machines take too long to commission and do not gain as much as promised when complete.

In order to evaluate the suitability of technology to the operating environment of the New Zealand solid wood processing industry, and to determine the relative costs and benefits of implementing of the technology, it is necessary to consider internationally standard techniques or procedures by which the effectiveness of the technology may be determined. Technology is defined here as techniques or machinery applied directly to a given process with a view to improving the effectiveness or efficiency of the process.

1.2 Traditional evaluation techniques

The traditional method of evaluating a manufacturing plant is to break down the plant into discrete elements that each perform a conceptually simple task. The value added to the product as it moves through the plant is summed to produce the total value added in the plant. This concept is known as the “Value Chain” (Tzafestas, 1997). Therefore, to evaluate the manufacturing process’s performance the process is similarly broken up into discrete elements and evaluated piece by piece.

Tzafestas later states that these elements need to be examined from different points of view, so that the total impact can be realised. Three views are suggested:

1. User View. The impact that the technology has on the operator or user. Such things as ease-of-use, speed, and effectiveness of the operator due to the technology are taken into account.
2. Technology View. The impact of the interconnections of the elements in the plant. Things such as throughput that affects bottlenecks, compatibility with neighbours, and plant logistics are considered.
3. Enterprise View. The cost of the machinery and maintenance and the changeover cost, as well as the overall value to the company as a business is part of this view.

Often it seems that one or two of these points are considered and well catered for when budgeting for a change in a plant, but very rarely are all three.

Currie (Currie, 1994) offers some techniques for measuring some of these factors, such as Payback Period and ABC¹, but points out that in order to embrace advanced manufacturing technologies organisational changes are required. Regular performance measures are stressed and some trusted management techniques are suggested, such as JIT², TQM³, and TPM⁴. Currie points out that if this is to be successful, then it needs to be part of a long-term (longer than 3 years) plan. However, in some large New Zealand forestry companies it is indicated that a payback period of less than 9 months is required on any new technology investments.

Regular measurement of processes and taking action on the information gathered seems to be the cornerstone of improving manufacturing processes. This seems

¹ Activity Based Costing

² Just in Time

³ Total Quality Management

⁴ Total Productivity Management

to be something that is taken for granted by manufacturing industries but is found lacking in the solid-wood processing industry. In the development of the syllabus of a Joint European Project education programme for computer integrated manufacturing the topic of process control was considered too basic for inclusion.

“Comparatively low attention is given to such problems as control theory and automation, although these subjects form an indispensable part of the education process. This is due to the fact that these topics are covered by separate publications and are traditional from a certain point of view.” (Adelsberger et al, 1995)

The New Zealand solid-wood processing industry needs to identify the factors that are crucial to its industry and then build a comprehensive process control programme around them before it can consider becoming a world-class manufacturing and processing industry.

1.3 Factors determining performance

Many factors contribute to the successful performance of a sawmill. In New Zealand the log resource has a large impact on a sawmill's performance. In every situation, each log is different from the next, and requires different processing in order to produce the optimum yield of lumber. However, *“Optimising the value of products from logs and lumber requires accurate information about the types and locations of defects...”* (Tian et al, 1997). This has led to a booming industry producing log scanners utilising more and more innovative techniques. For instance the Lasar™ log imaging system developed by Perceptron, Vancouver, Canada, which uses a modified conventional laser log scanner and records time-of-flight data rather than triangulating the reflection with a CCD camera. This gives a unique three-dimensional map of the log from a single point of view in one single 'snapshot'. Many of these products have been produced for northern hemisphere hardwood species, and are therefore not always suitable for New Zealand radiata pine due to differing feature characteristics.

There is also a factor of uncontrolled use of the machines, even when they are suitable for the job. Libeda (Labeda, 1993) states “... sawmills invest huge amounts of money ... and then they do not control the effect of their function”. Once scanned and a solution generated, the process must be monitored in order to determine the level of deviation from the ideal solution.

One of the most common factors used in today’s mills to evaluate performance on an individual and aggregate machine basis is sawing variation, and ultimately saw stability. A survey of New Zealand mills in 1986 (Doyle, 1986) showed that the average standard deviation in lumber size was 1.318mm and was allowed for by over-cutting the final dimensions by 2.79mm. A general rule of thumb used in the forestry industry is that reducing the over-cut by 1mm will produce another 1% of annual turnover in revenue. Consequently, there is a lot of research in reducing sawing variation.

The Operating Envelope (Beauregard, 1995; Lunstrum, 1985) has been used in New Zealand as a guide to keep saw machines within limits as dictated by allowable sawing variation.

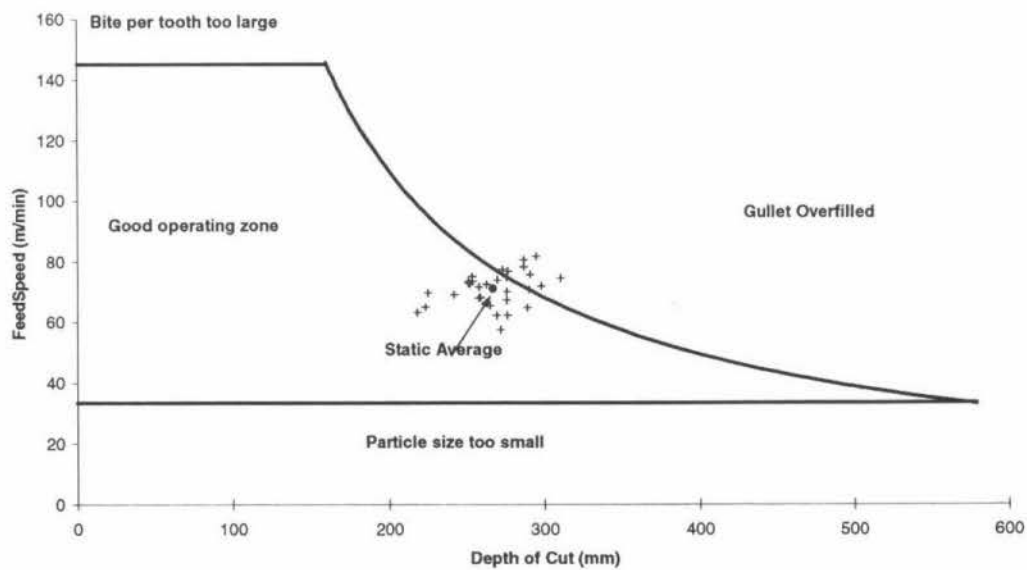

Figure 1-1: Operating Envelope

70% of the tooth gullet filled with sawdust upon exiting the cut has been determined to be the maximum allowable limit before excessive sawing variation occurs, as illustrated by Lunstrum (1985, page 4). The Maximum and minimum feed speeds for a workpiece are calculated from the bite per tooth that the saw design can handle, and the 70% gullet filling line is calculated from the depth of

the cut and the feed speed. This produces a closed envelope as shown in Figure 1-1, where the best operating position is next to the curved 70% line and just inside the envelope.

Analysis of vibrations in sawblades have been researched in Canada for some time and have shown that “... *because of a combination of some avoidable and some unavoidable circumstances real bandsaws always vibrate even during idling conditions*” (Hutton, 1997). There has been research to try to understand and perhaps remedy some of these circumstances using theoretical physics, especially on circular saws, such as Sindre Holøyen’s work at the Norsk Tretensik Institutt in Norway (Holøyen, 1983), and has had limited success in translating into today’s sawmills. Other researchers have attempted to remove vibrations using innovative damping techniques, irrespective of the causes of the vibrations. A fairly successful example is the work performed by Tan, Huang, and Fan at Wayne State University, Michigan. He states “*The on-line control is performed through a DSP (Digital Signal Processor) board and control actuation is provided by non-contact electromagnetic forces*” (Tan et al, 1997). Vibrations in the affected saw are reported to be “*significantly reduced*”.

One of the most common methods that is used to keep a saw stable is a guide. Usually, a guide is a lubricated, composite rubber block placed on either side of the non-cutting surface of the saw. Gary Schajer stated that in 1985 “*About half of the rotary gang-saw machines currently in use have guided sawblades*” (Schajer, 1986). However, it has been noted that guides in bandsaws are not designed to eliminate some non-vibrational instability. Taylor (Taylor et al, 1997a) states “*Laboratory and sawmill cutting experiments have shown that bandsaws tend to cut off-line, i.e., the mean sawblade displacement during the cut is biased toward one side.*” Taylor is currently investigating methods of reducing this effect.

The preparation in the sawshop is just as crucial as setting the guides up correctly. Chabrier (Chabrier et al, 1999) gives a good overview of the different aspects of saw doctoring listing some of the attributes that should be measured and benchmarked before a saw is released into service. Some of the factors mentioned include critical speeds, blade tension, and temperature effects, and the interaction of the three. The differences between static measurements on the saw

bench and dynamic measurements when the blade is spinning are also highlighted as important.

The surface finish and the visual grading of the product are areas that have been largely subjective. Features such as roughness and knottiness have only recently been able to be measured in an objective way. At the Institut für Werkzeugmaschinen und Fertigungstechnik in Braunschweig, Germany, “... *a new method is being designed and tested which can separately evaluate topographic characteristics originating in the wood anatomy and in the machining process by means of image processing*” (Westkamper et al, 1995). They suggest that the quality measure in this respect is a signal to noise ratio of the visual and tactile effect of the natural wood characteristics versus the machining marks.

With the advent of the Resource Management Act, the noise produced as a side effect of the process can be considered a performance criterion. Rhemrev (Rhemrev et al, 1997) shows how noise levels can be monitored objectively and how saws may be redesigned to reduce the noise level without reducing throughput. Conjecture within the industry is that low noise saws also produce less sawing variation due to the reduction of single frequency vibration in the saw, but this has yet to be tested.

Productivity and the economic bottom line seem to be the major driving factors in determining performance. However, Holøyen (Holøyen et al, 1991) states that sawmill productivity, as opposed to production, is not measured effectively if only described in subjective terms. He suggests an objective scheme of on-line productivity measurement to remedy this. Ultimately, a sawmill is part of a business; in order to evaluate any advance in sawmilling practices, the monetary effect on the business of any change must always be taken into account.

1.4 Outline of Thesis

There are several techniques in advanced manufacturing and processing industries that could be applied in the New Zealand solid-wood processing industry to better evaluate new technology. While these techniques are standard in other industries, they are not being regularly applied within sawmills. Part of

the problem here is that many of these techniques require regular measurement of pivotal process variables in the form of data, and this data is not readily available in most mills. Many process variables and the techniques required to measure them are available, but it is unclear which variables are pivotal to the sawmilling process and exactly what their interactions are. The research programme that encompasses this thesis is focussed on identifying and ranking these factors and their interactions as a first step towards world-class status. To achieve this, we need to have available a fully instrumented sawmill that is capable of providing the required data.

Chapter 2 describes the requirements of such a facility. While fully instrumenting a sawmill is beyond the scope of this project, this chapter goes on to describe the requirements in instrumenting a single machine station, the headrig bandsaw. The instrumentation set up as part of this thesis is described in chapter 3. The design of the software that captures the information, and makes it available to both the user and the technologist is described in chapter 4.

One of the significant problems identified in current sawmills is sawing variation. Chapter 5 describes an experiment whereby the initial system is tested by gathering and analysing data relating the effect of log density on saw variation. Two key variables measured are blade deviation and bandwheel displacement.

In order to evaluate the success of the project key performance criteria of the information system are measured. Chapter 6 details the results of these measurements, in particular the responsiveness of the system, and discusses the implications.

The final conclusions are made in Chapter 7, which are then set back into the context of the greater research programme. The scalability of the single machine model to a mill-wide system through the use of a local network is discussed.

Development of a Headrig Process Information System

2. Facility Requirements

2.1 Introduction

A facility is required that can be used to identify and quantify the pivotal process variables for the sawing process. The facility would become a steady measurement base with which to benchmark the effects of the different process variables, and even different measurement techniques on identified pivotal variables.

Once the pivotal variables have been identified, and their effect on output quality determined, more efficient process control strategies can be developed for use within New Zealand sawmills.

2.1.1 Current situation

Currently *Forest Research* performs sawmill improvement science using loosely standardised, and at times ad hoc, equipment and measurement systems. Many systems are made to purpose for a particular study, and may be disassembled for parts for the next study once the study is complete. Although this means that each measurement system is fit for purpose and exactly meets the requirements of the study, reproducibility and consistency between not dissimilar projects can suffer.

All of the equipment used is portable. The apparatus is designed and built at *Forest Research* and used in the lab to ensure reliability. It is then typically taken to a number of sawmills around the country and used in real life situations, so that the science and technology developed at *Forest Research* is relevant and applicable to the supporting industry.

This approach offers maximum flexibility since it is rebuilt for every study according to that study's requirements. Flexibility is a major concern in this research field. Because very little is known about the technical aspects of the process many extremely different process variables may need to be measured at the same time. Flexibility is required to enable new techniques and equipment to be used effectively.

2.1.2 Proposed situation

The proposed system takes a different approach, which is designed to complement the existing system. Rather than designing the apparatus to be sufficiently portable to take to a number of mills, the apparatus is designed for greater effectiveness and placed in a permanent mounting in a commercial sawmilling facility. This creates a benchmarking facility that can employ equipment with greater precision (and therefore, usually, greater fragility) and can be used to compare different process variables with greater consistency and comparability.

The overall project goal is therefore to create a commercial sawmilling facility that is wired to a comprehensive process monitoring system that has the flexibility to add, change, or remove sensors and analysis routines as required, and the consistency to be able to provide comparable data for benchmarking purposes.

The needs and risks identified in the following sections are based on the template provided by Pressman (Pressman, 1992).

2.2 Functional Requirements

The overriding function for the system is to gather the data from the assorted sensors and store it for analysis. Functionality required by all sensors includes scaling and time-stamping.

Since it cannot be known in advance what process variable will be key to a particular technology, the system needs to be modular both in terms of its electrical and software architectures. Sensors must be able to be added or removed easily, and any processing or analysis of the data gathered must also be modular.

Analysis of the data is performed by modules specific to the information required. The specific modules used must be able to be added, altered, or removed from the system at will. Display of the process information is directly related to the desired analysis so each analysis module has an associated display routine.

Extensibility and modifiability are high priorities for the system. Evaluating new technological breakthroughs and new techniques is a core reason for the developing this system. Quick and easy addition or modification of the system to accommodate new innovations is required.

2.2.1 Business Requirements

Fully instrumenting a sawmill to gather all relevant data is a long-term project. The system needs to be designed with enough flexibility and a sufficiently broad scope to be relevant to the changing needs of the parties when completed.

The sensitivity of the project also needs to be considered. The success of this project may lead to the dependency of the sawmill on the operation of the system, particularly if extended to automated controlling of some of the machinery. The system, therefore, must be adequately robust to continuously operate through a working day, or at a minimum, degrade gracefully.

2.2.2 Technical requirements

Connectivity of the various devices to the computer is the biggest technical risk present. This can be managed by designing the interface to be as general as possible.

Another technical risk is that the complexity of the system could lead to the speed performance becoming less than adequate. The process of collating the data and processing it needs to be streamlined for speed of operation.

The system will run in conjunction with any other systems currently in place in the sawmill environment. Parallel operation resulting in data collection and display with minimum interference in the standard operation of the sawmill is the primary goal. Once this is established, future modifications of the system could lead to control of some parts of the operation, such as feedspeed regulation or blade speed adjustment.

2.3 Chosen Facility

The facility that has been chosen to meet all the previous criteria is the mill at the Timber Industry Training Centre (TiTC) in Rotorua. It is part of the Waiariki Institute of Technology and is used to train all the solid-wood processing trades-

people in New Zealand. TiTC cuts timber for sale on the commercial market, but uses students to staff the operations under the supervision of the tutors. Students are sourced from both high school graduates and from apprentices in industry. Teaching new technological breakthroughs, once tested, will be easy to manage at TiTC. It is also situated only 12km from the *Forest Research* campus, which makes the project easier to manage.

The scope of this programme is limited to the control of a green sawmill. That is from the entrance of a log from the log yard into the sawmill, up to when the finished green (undried) products are placed on the green sorting table. It does not include log yard activities, stock purchasing, or any post-processing of the green product such as drying, treating or planing.

2.4 Application to headrig bandsaw

To demonstrate the feasibility of the system design, the project is initially restricted to a single machine station. The selected machine station is then modified to monitor some of the more commonly identified process variables. When this has been completed, other machine monitoring stations can be built more efficiently in subsequent projects using lessons learned from this project.



Figure 2-1: The headrig bandsaw at TiTC

The headrig bandsaw (see Figure 2-1) was chosen because it cuts the logs into slabs for further processing, and therefore handles every piece that goes through the mill. This means that it is arguably the machine that has the most effect on the operation of the mill. It is also only five years old, and has electric motors that can provide diagnostic information quickly. The headrig is also relatively

easy to access when adding sensors when compared to some more enclosed systems such as the circular gang saw station. In order to monitor this machine centre effectively and with further expansion into the mill beyond a process information system needs to be properly specified and designed.

2.4.1 Current headrig station

The TiTC training sawmill currently has some equipment installed that can be used for process monitoring. The logical flow of material through the primary breakdown area of the sawmill is illustrated in Figure 2-2.

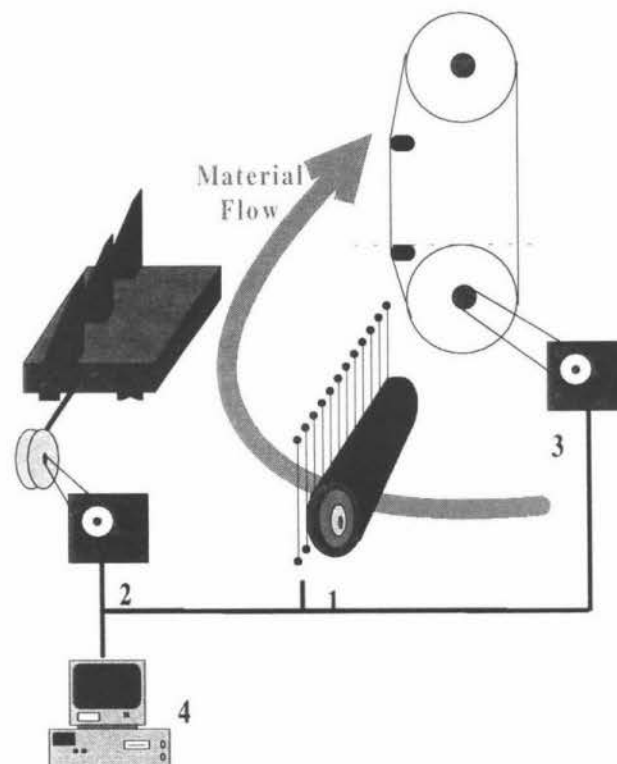

Figure 2-2: Logical Layout

The log is passed through a shadow scanner (1), which measures the large end diameter (LED), the small end diameter (SED), and the length of the log. This information is displayed to the operator who uses it to position the log for cutting.

The log is then positioned onto the log carriage driven by an electric motor (2) via a winch. The electric motor (VectorDrive by PDL) provides diagnostic information that is currently being captured using a SCADA package on a DOS

based machine in the operator's cabin (4). However, this information is not being used presently.

The log is then cut by a 5 foot headrig bandsaw (the band-wheels are 5 feet in diameter) which is driven by another identical electric motor (3).

2.4.2 Instrumented headrig station

In addition to the data from log carriage motion controller, two measurement points are to be added on the headrig bandsaw itself, as illustrated in Figure 2-3.

The first measures the blade itself. A sensor will need to be mounted on the bottom saw guide to measure the lateral blade deviation. This measurement is crucial because it directly relates to how well the saw is performing, and possibly relates to the thickness variation of the boards cut. The bottom guide is chosen because this is where the saw leaves the log as it travels downwards through the cut.

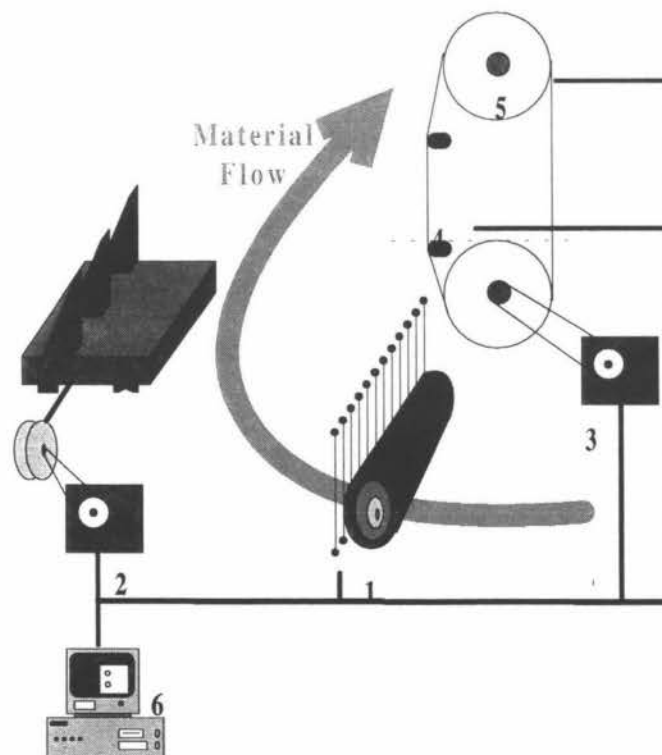

Figure 2-3: New Logical Layout

The second added measuring point is on the top bandwheel. The top wheel is forced upwards to keep the blade straight, and then sprung with a mechanism to keep the strain on the blade constant and damp any vibrations. A sensor will be

mounted onto the fixed shaft of the saw structure and measure the vertical movement of the floating top wheel. This provides a measure of the effectiveness of the vibration damping system built into the wheel suspension.

Another enhancement to the physical system will be an upgrade of the computer in order to accommodate disparate data sources, and to run the data collection in separate processes to the display and analysis processes. This was achieved by upgrading to a Pentium-based PC running Windows NT.

2.4.3 Headrig specific requirements

The core function of the software is the ability to log data for a specified trial, in order to have results to draw conclusions from. The data will be acquired from disparate sources, and needs to be collated before storing. Each event needs to be recorded in sequence to facilitate analysis of the behaviour of the machine station, and would therefore require timing information to be stored with each event. This is also crucial to synchronising any data collection not controlled by the system.

Data analysis and business software should be modular to allow for changing interpretations of the data when testing new theories in research. Some basic modules need to be provided at the outset. They are as follows:

- **Operator Display:** This module shows the basic operating variables in real time in a graphical form that can be easily and quickly absorbed by the operator during cutting. Variables that must be included are: feed speed and position, blade movement, and cycle times
- **Operating Envelope:** This module shows the operating envelope for the current configuration, given the properties, and a real-time 'worm' of the feed-speed and depth of cut. This would show the capability of real time calculation.
- **Statistics Compiler:** This module shows statistics gathered over a given time period. This would show the database storage and retrieval capabilities of the system.

The minimum response time to display data to the user should be before the start of the next cut, although it would be preferred that the data is displayed in real time.

2.5 Summary

A facility for identifying and measuring sawing process variables primarily for benchmarking purposes is specified. Flexibility and reliability is outlined as of utmost importance. The ability to add, alter, or remove components and routines from the system is required, as well as access to the information across a local area network.

The Timber Industry Technology Centre (TiTC) is chosen as the facility to be fitted with process monitoring equipment. TiTC has the added advantage of being a teaching facility, which will aid the transfer of information about new technological breakthroughs to the industry.

The scope of this project is restricted to the headrig bandsaw, in order to assess the feasibility of the system, and to refine the design of the mill-wide system. The initial process variables that are required to be monitored are the feed speed and position, the lateral blade position, and the vertical position of the top bandwheel. In addition to the key functionality of collecting and storing the data on disk, some analysis and display of information to key users is required. The areas identified are an operator display, an operating envelope display, and a statistics display.

2.6 References

PRESSMAN "Software engineering: A practioner's approach."International Edition, pp24. 1992. Singapore, McGraw-Hill.

Development of a Headrig Process Information System

3. Instrumentation

3.1 Equipment Selection

Within the headrig bandsaw machine station, there are several process variables that may affect both production rate and product quality. These variables require instrumentation to both measure the absolute values and also the effects the variables have on the process.

The variables to measure are log feed speed, lateral saw movement, and vertical bandwheel movement.

3.1.1 Log Feed Speed

The speed that a log or any piece of wood can be fed into a saw has long been recognised as crucial to keeping the saw stable (Quelch, 1964).

In many sawmills, the most expedient way of measuring log feed speed is to mount a rotary encoder either on the carriage winch if it is winch driven, or on the carriage wheel itself. This gives a direct reading of shaft angle, hence carriage position, and the speed can be derived from this by differencing.

However, in this sawmill we were fortunate to have an electronic system controlling the carriage movement through a “VectorDrive” electric motor (see Appendix: Technical Data pi). The manufacturers of the controller, Jaymor Industries Ltd, were able to provide a software data link to provide speed and position directly from the motor controller. The motor controller also uses a rotary encoder, but it is sealed from the corrosive environment and is geared to the motor so as to eliminate slippage.

3.1.2 Lateral Sawblade Movement

The amount of sawblade movement across the log as it is cutting will determine the flatness of the products either side of the cut. If the sawblade vibrates, then the timber surface can appear wavy or ridged. A substantial amount of work has been committed to controlling this movement throughout the world. An example of this is an experiment into moving the saw-guides in order to stop the saw ‘jumping’ into the log on contact, called cutting bias (Taylor et al, 1997b).

Probes can be used to measure displacement very accurately. Either linear resistors or the more expensive linear variable differential transformer (LVDT) can be used quite effectively (see Appendix: Technical Data pii-iii). An LVDT uses the displacement of the transformer core to affect the coupling between the primary winding and two secondary windings. The advantage LVDTs have over linear resistors is that they have an active output, making them more resistant to signal interference, and less affected by temperature change. The disadvantage of using probes on such a fast moving surface (approximately 40 m/s) is that friction very quickly heats up the probe decreasing its effectiveness. Rollers can be attached to the probe but this decreases the precision. The speed at which the probe can move is also a limiting factor for measuring sudden jumps.

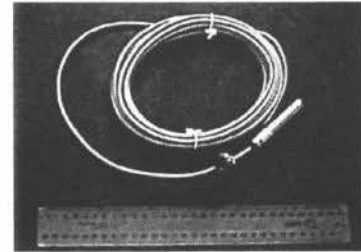

Figure 3-1: Inductive Proximity Sensor

Inductive eddy current sensors have been used successfully in the sawmilling industry for many years, and have even been given the trade name of “Curve Catcher” (see Figure 3-1, Appendix: Technical Data piv). These are non-contact sensors that induce an electric field that the blade passes through. The distance from the end of the sensor is determined from the effect that the metal has on the electric field, which in turn causes a back electromagnetic force in the

sensor. This is an active sensor providing relative immunity to environmental changes. This proximity sensor also has a relatively fast response (~40 ms) because there are no moving parts involved.

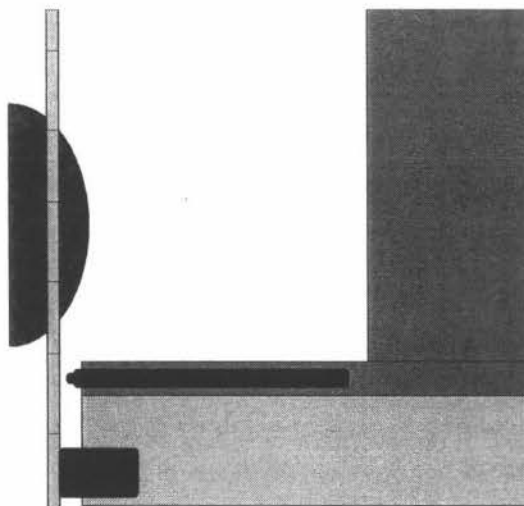

Figure 3-2: Proximity Sensor Mounting

The inductive proximity sensor will be mounted above the lower saw-guide. The sensor will be mounted inside a metal tube and placed on the leading edge of the slab deck. The slab deck slopes downwards at this point placing the sensor just below the lowest point

of the log as it is cut. This point on the blade is where the blade exits the log, so it is the best point for measuring the most movement of the blade.

3.1.3 Vertical Bandwheel Movement

The top wheel of the bandsaw is raised by hydraulics to provide tension on the blade, and then set on a mechanism to keep the tension constant and damp out oscillations from cutting heterogeneous material. In the case of the headrig bandsaw at TiTC this mechanism uses a combination of hydraulic and pneumatic cylinders to provide both lifting power and softening of shocks. As the blade stretches from heat and bucks from shocks the wheel lifts and drops in order to keep the blade tight and straight. The performance of the strain system is considered a vital function (Wijesinghe, 1998).

The movement of the wheel can be measured safely on the arm that is used to move the wheel's axle vertically. Either probes or a proximity sensor as described for the blade movement are candidates for measuring this variable.

The LVDT is the best choice because of its physical and electrical ruggedness (see Figure 3-3). The wheel needs to be lifted to different heights depending on how stretched the saw is, which is a function of saw age. This means the sensor also needs to be adjusted

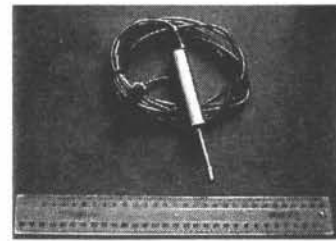

Figure 3-3: Linear Variable Displacement Transducer

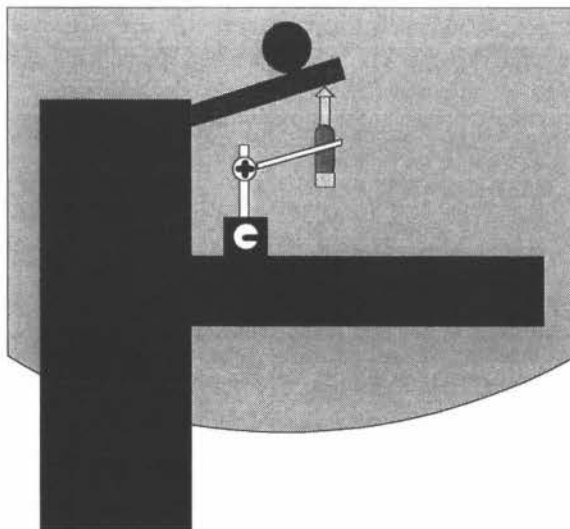

Figure 3-4: LVDT mounting Position

with each saw change. The wheel may only move fractions of a millimetre when in use, and move ten or twenty centimetres in a saw change. It is easier for a sawdoctor to put an LVDT into the middle of its range than a non-contact sensor. The other reason for selecting an LVDT is the precision of the measurement. Inductive proximity sensors are limited to tenths of a millimetre, where the more

positive probe systems can measure down to hundredths of a millimetre.

The LVDT will be held with an adjustable clamp that can vary the base height of the device to match the base height of each blade. The LVDT can then be locked in place, but if the height suddenly drops below the stroke limit of the LVDT the arm will drop without damaging the sensor.

3.2 Data Capture Device

Flexibility and reliability were the major driving factors for deciding which device to use to capture the electrical signals for computer analysis and storage. The National Instruments range of data acquisition boards has traditionally been used in the sawmill technology group at *Forest Research*. This provided assurance of the reliability of the products and the economic factor of already owning the drivers and software required to use them. Therefore, it was decided very early on that National Instruments equipment would be used.

There is a good range of specialty boards available that provide high capture rates or high immunity to noise but are restricted in the flexibility of the type signals that can be acquired. With this in mind the PCI-1200 low-cost, general-purpose data acquisition board was purchased (see Appendix: Technical Data p-viii). This board has four differential analogue input channels for devices such as the LVDT and inductive proximity sensor, three eight-bit digital ports, three counters for devices such as rotary encoders, and a good range of triggering options. This flexibility means that the process information system can readily have new devices added to it.

3.2.1 Wiring Structure

The electrical connections involved are shown in Figure 3-5. The analogue devices such as the inductive proximity sensor and the LVDT are connected to the data acquisition board, converting the voltages into values, and the log positioning data is provided through the Jaymor *Flight Recorder* and its associated PLC controller.

There is allowance made for a possible second computer in the mill that would be used to separate the Jaymor *Flight Recorder* from the data server if processing power becomes a bottleneck.

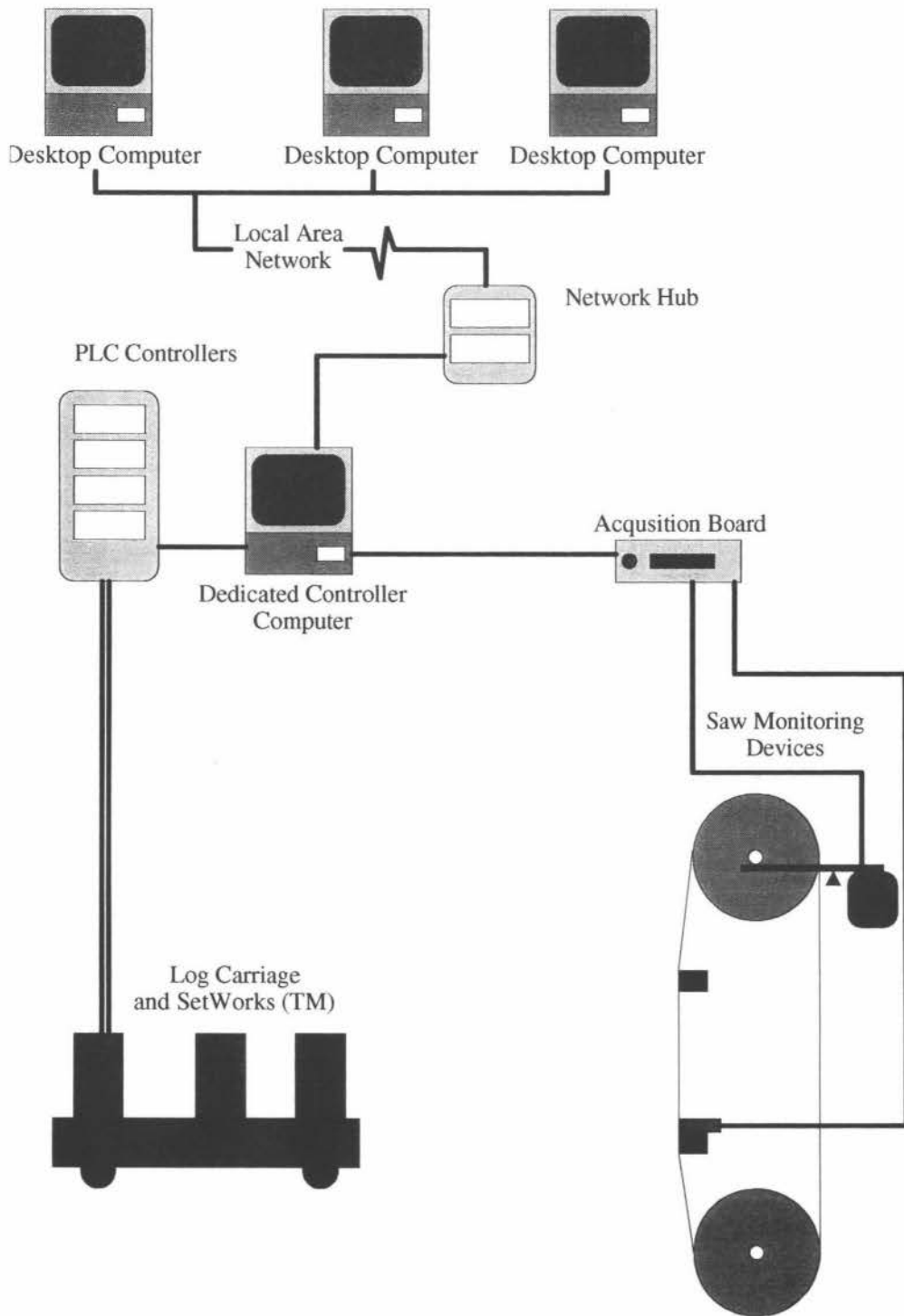

Figure 3-5: Wiring Diagram

3.3 Calibration and Error Management

3.3.1 Electrical noise

Electrical noise is a major concern inside sawmills. There are typically many machines using large motors that are constantly switching on and off and generating waves of electrical fields over the signals being recorded.

To combat this all cables between the machinery and the data capture computer are shielded and appropriately earthed. Using differential channels on the data acquisition unit also reduces the effect of electrical interference by measuring the difference between two signals similarly affected by noise, which effectively eliminates the noise common to the two. Frequency filters implemented in hardware are not used as they may remove important information. If dominant noise frequencies become a problem they may be removed with a software filter at a later stage.

3.3.2 Device Calibration

Both the LVDT and the inductive proximity sensor have been calibrated using test equipment at *Forest Research*. The basic methodology is as follows:

The device is mounted on the test machine. This machine consists of a vertically moving clamp with a vernier graduated scale, and a clamp for holding the test piece, which is a piece of sawblade in this case. The device is then zeroed on the test piece and moved vertically, recording the output against the reading on the scale. This is repeated to produce ten sets of data, five rising and five falling, to account for any hysteresis, and then regressed to form a linear relationship through the collected data. The averaged results are shown in Figure 3-6 and Figure 3-7. The regressions are shown with the independent variable (mm) on the y-axis. This is because of the way the regression is used. Measurements made by the transducer are in terms of voltages and these are converted back to millimetres using the equation shown on the graph as shown.

The feed speed is calculated from the winch pulley diameter and the rotary encoder. The only way to alter the result is to tell the motor controller that the pulley diameter is different. All other calibrations are performed in the factory.

Upon installation, the company performed timing tests and declared the unit to be adequate.

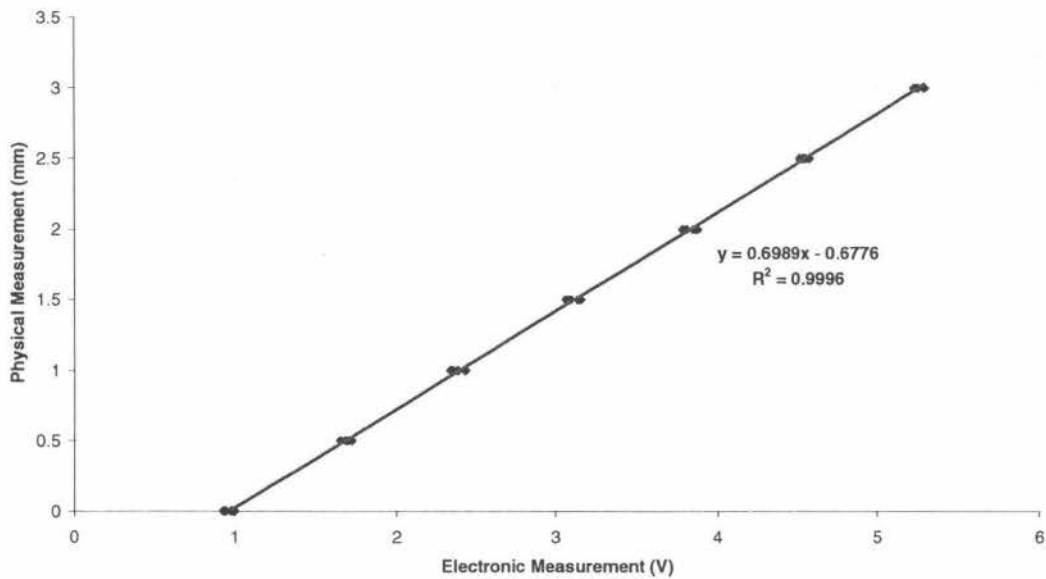

Figure 3-6: Proximity Sensor Calibration (12V supply)

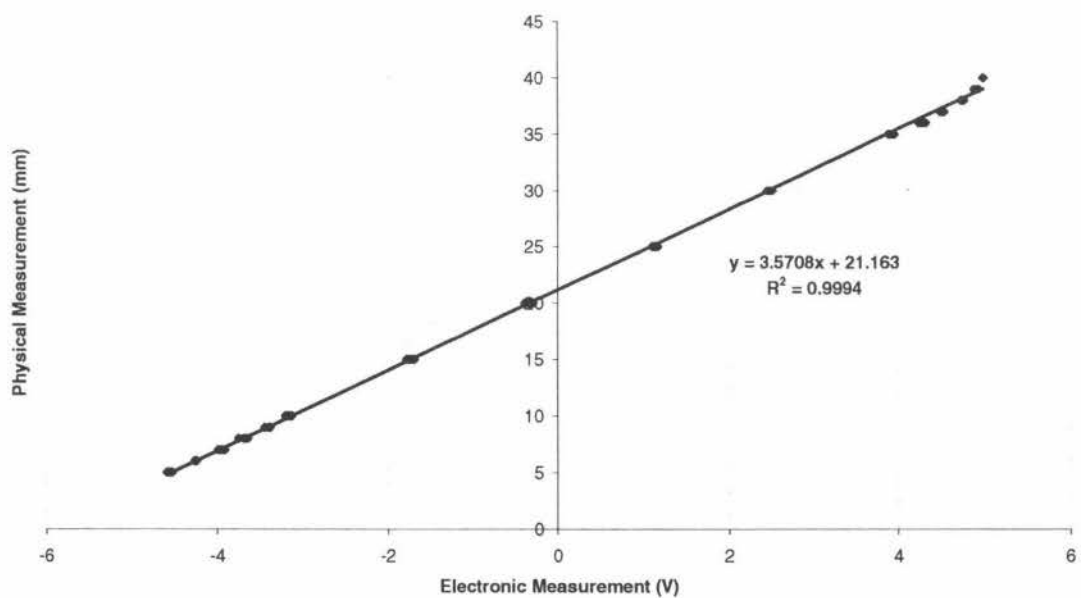

Figure 3-7: LVDT Calibration (12V supply)

3.4 Summary

The process information system collects data about the blade movement, top band wheel movement and log speed and position as the machine cuts logs into slabs for further processing into finished timber products.

Jaymor Industries Ltd constructed the log positioning equipment and provided a software data link to the data collection program. The other sensors are monitored through a PCI-1200 National Instruments data acquisition board. An inductive proximity sensor is mounted above the lower saw guide to measure lateral blade deviation, and a linear variable displacement transducer is mounted on the top bandwheel axle shaft to measure the movement of the top band wheel.

All signal cables are shielded from electrical noise and differential channel monitoring is used to remove noise common to both signal and reference lines. The analogue devices have been calibrated and checked for hysteresis using *Forest Research* test equipment.

Development of a Headrig Process Information System

4. Software Design

4.1 Introduction

Software was developed to gather the data from the various sensors and present the information to the user of the system. The role of the software is to provide both an interface to the user with the sensor hardware, and to provide an event-based database of the data collected from the sensors.

The software was developed in-house especially for the project using Microsoft Visual C++ programming environment. It was decided to develop the software in-house to provide the most relevant solution that was very flexible and maintainable for future enhancements. Although SCADA systems are becoming more configurable they are prohibitively expensive, requiring licences for each implementation point. The cost of purchasing the chosen product was able to be spread across a number of projects and can provide more functionality as a SCADA system. Visual C++ in particular was chosen because it is used in other groups in the business providing an ad-hoc standard throughout the organisation.

4.2 Architecture

The architecture of the software is broken into modules that handle the different aspects of the tasks required. Figure 4-1 illustrates the division and characterises the modules into inputs, outputs, processing, user interface, and maintenance tasks. The shadowing of some modules indicate that there are many different modules of this type.

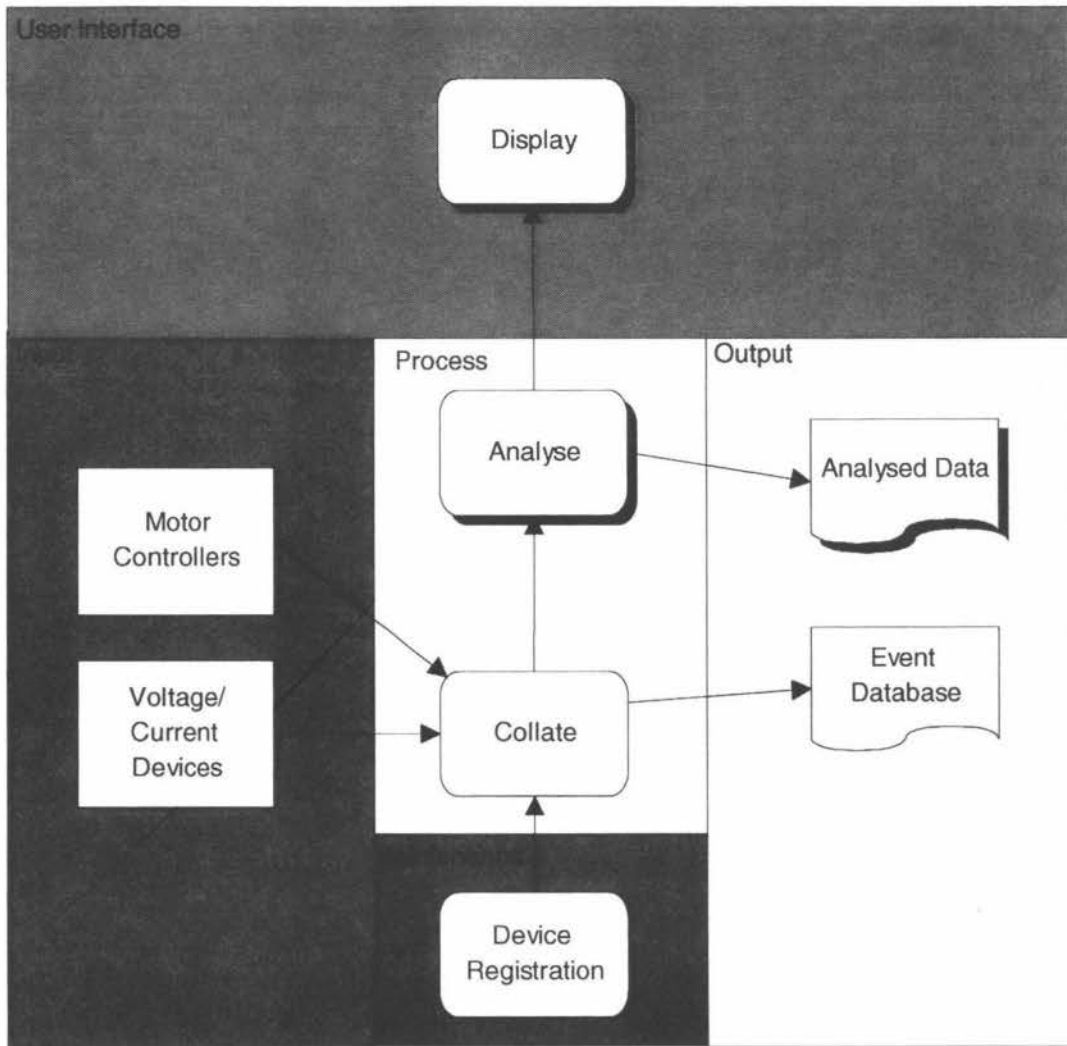

Figure 4-1: Architecture Context Diagram

A client-server architecture was decided upon to allow maximum flexibility and scalability. The central server collects the data from the various devices, scales the data into useful units, transforms the data into a regularly formatted event description, and saves the data to disk with a time-stamp. This forms the central core of the program. Clients then get the relevant data from the server and analyse the data to produce the desired information about the process, and then display the information to the user. The information may then be stored in a separate disk file if desired. This decoupling of the data collection function from the analysis and display function enables greater flexibility in adding and removing analysis routines from the system.

Communication between the server and the clients is enabled through two mechanisms: TCP/IP and Dynamic Data Exchange (DDE). TCP/IP is the

preferred mechanism that sends the data across a local area network to the client using the same technology that the internet is based upon. The large base of software written for internet communications provides plenty of resource information about implementing communications, and for support. The mechanism is, however, dependent on the operation of the local area network to provide the transport. Even if the client is on the same machine the data still flows through the network drivers.

DDE communications are provided in the event that the network fails. DDE transport is provided by the Windows operating system itself, and is provided to enable data transfer between programs running on the same machine. This mechanism will not provide data over the network, only for clients running on the same machine as the server.

By using a network-based communications method the data collection and the data processing is further de-coupled, allowing the clients to run on an entirely different machine.

4.3 Data Flow

The data flow through the process, as illustrated in Figure 4-2, is from the devices in the mill through the TiTC Process Information System to the users' screen and the disk files. Data is collected through the Jaymor "Flight Recorder" and the Data Acquisition (DAQ) card and stored on disk for future reference.

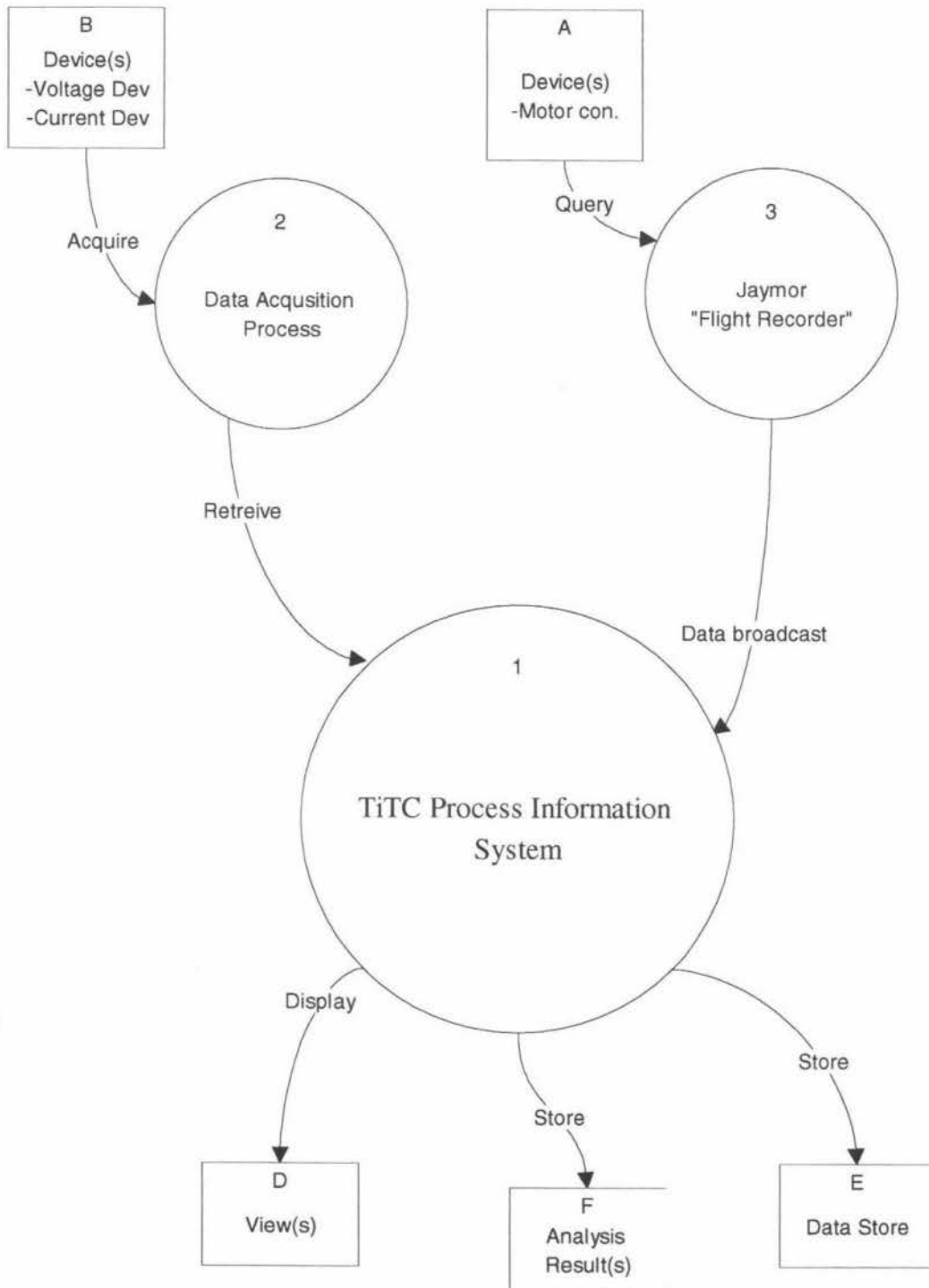

Figure 4-2: Data flow Diagram

Figure 4-3 shows the expansion of the *TiTC Process Information System* process. The devices are queried by a *Monitor* process, which stores the data onto disk and provides the data to the *Link Manager*. The *Link Manager* provides the TCP/IP and DDE links to the *Analysis & Display* modules (clients), which then provide the displays to the user and save any analysed data to disk.

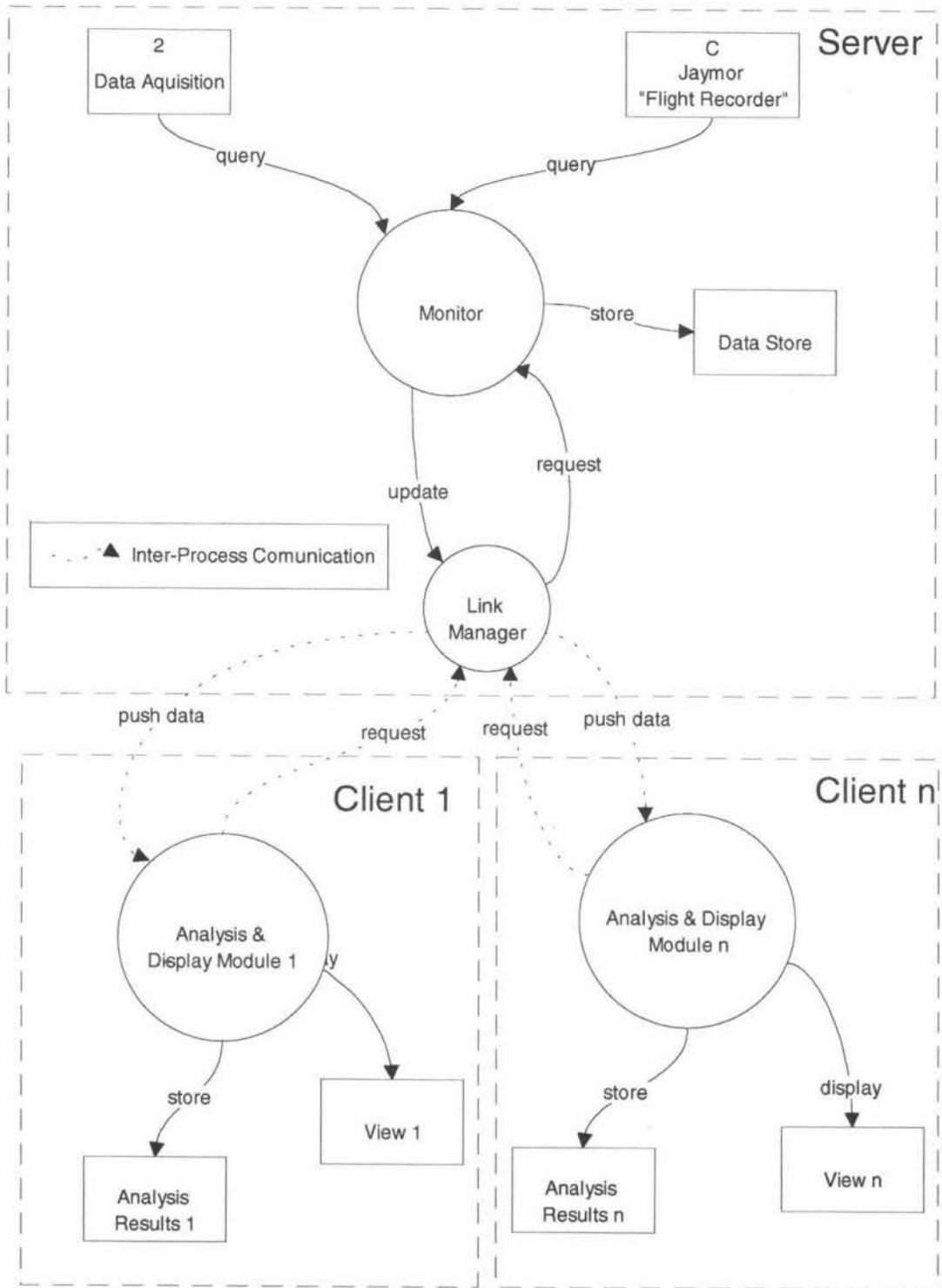

Figure 4-3: Expansion of the data flow through the TiTC Process Information System

4.4 Server Software

The server software has two basic parts: the *Monitor*, which collects the data from the devices, scales it, time-stamps it, and stores it on disk, and the *Link Manager*, which makes the current data available to the clients.

4.4.1 Monitor

This module's major function is to monitor the data coming from the various devices mounted on the headrig and store the data into an event storage file. The second function is to provide data via the link manager to other processes for further analysis and display.

Each variable monitored can be accessed through the *Link Manager* to acquire an immediate value of the variable. The relevant device is queried upon request and the value returned. In addition to this certain variables are logged to produce a stream of data over the duration of a cut. This log of data is kept in a buffer and can be queried at the before the end of the next cut.

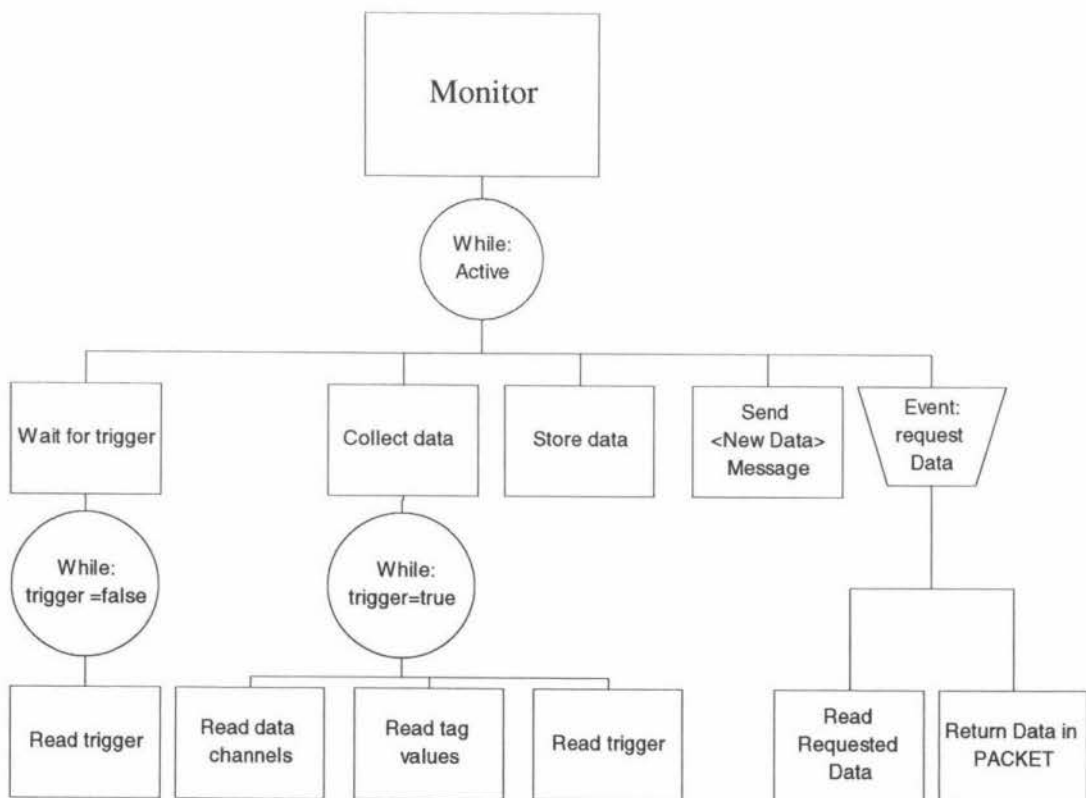

Figure 4-4: Monitor Program Structure

The data for each variable is acquired from the devices at a rate of 50 times a second by the hardware of the data acquisition card and stored in a buffer managed by the card. The data logs are copied from this buffer into a separate memory buffer for each log at the same rate. Any one of the variables registered with the server triggers this process. If the data logging process is not currently triggered then the trigger variable is the only variable being monitored actively at the same rate. When a data value is requested the data is copied from the buffer managed by the data acquisition card, or if it is not logging then it is acquired specifically for the request. The different acquisition modes do not significantly change the response time of the request.

4.4.1.1 Data Organisation

A dBase IV database is used to store the event data from the *Monitor* because it is an openly known data format that can be easily accessed by third party programs, and it is simple to implement. This database format includes basic data types such as character strings and numbers, as well as complex data types such as dates. The basic data structure used to store the event-based data from the server and controllers is described in Table 4-1.

Table 4-1: Event database table format

Field	D	T	Span	Event	Data
<i>Type:</i>	<i>Date</i>	<i>Char(10)</i>	<i>Char(10)</i>	<i>Char(20)</i>	<i>Char(250)</i>
<i>Description</i>	Event Date	Event Time	Length of time event took	Event Type	String of data associated with type
<i>eg</i>	02/09/2000	16:32:43	00:00:11	FeedSpeed	[String Block]

The event types and associated data blocks are as follows:

- FS (Feed speed), FeedPos (feed position), DOC (Depth of Cut), Wheel, Blade: Analogue data that is saved as a stream that can be interpreted as a graph. If the data exceeds 250 characters a second event row is stored with the same Event, Date, Time, and Span values.
- Log: A single number indicating a log change (0) or a log turning operation (90, 180, or 270)

- **SawChange:** A single binary value indicating the start of a saw change (0), and the end of a saw change (1). A sawchange occurs when the teeth on the saw are blunted and the saw requires changing. This happens approximately once every four hours.
- **Pattern:** A text description of the sawpattern used to cut the following logs.
- **LogType:** A text description of the type of log to be cut next.

An array of named dynamically allocated data blocks is kept for the previous cut, and another set is kept for the current cut. When the cut completes the previous cut is discarded, and the current cut data block replaces it. The current cut data is also written to disk at this time.

The data sources are set-up through the use of an initialisation file. In the file a trigger source reference is stored, the data sources are named and the source is categorised, and the variables that are to be logged are named. The file structure follows the standard windows *.ini structure and is described as follows:

Table 4-2: Description of Monitor Initialisation file

Variable	Type	Choice	Comments
[Hrig Monitor]			Section Header
Trigger	String		A source name defined below
TriggerThresh	Decimal		The triggering value for the channel
TriggerOver	Integer		0=trigger when below threshold
			1=trigger when above threshold
nSources	Integer		Number of registered sources
SourceX		A<y>	An analog variable. X is the source number and y is the physical analog channel number.
		D<y>	A digital variable. y is the physical digital channel number
		String	A variable from the Jaymor <i>Flight</i>

			<i>Recorder</i> . The value is the name as requested from the <i>Flight Recorder</i>
SourceNameX	String		The name that source number X is hereafter referred to
nLogs	Integer		The number of variables that are kept in cut-based data logs
LogX	String		The name of the source as defined above to be logged. X is the number of the data log.

4.4.2 Link Manager

The *Link Manager* module is the “middle-man” module. Information flows from the *Monitor* module through this module and to various *Analysis & Display* modules. The *Link Manager* handles the communications and ensures that the information flows smoothly.

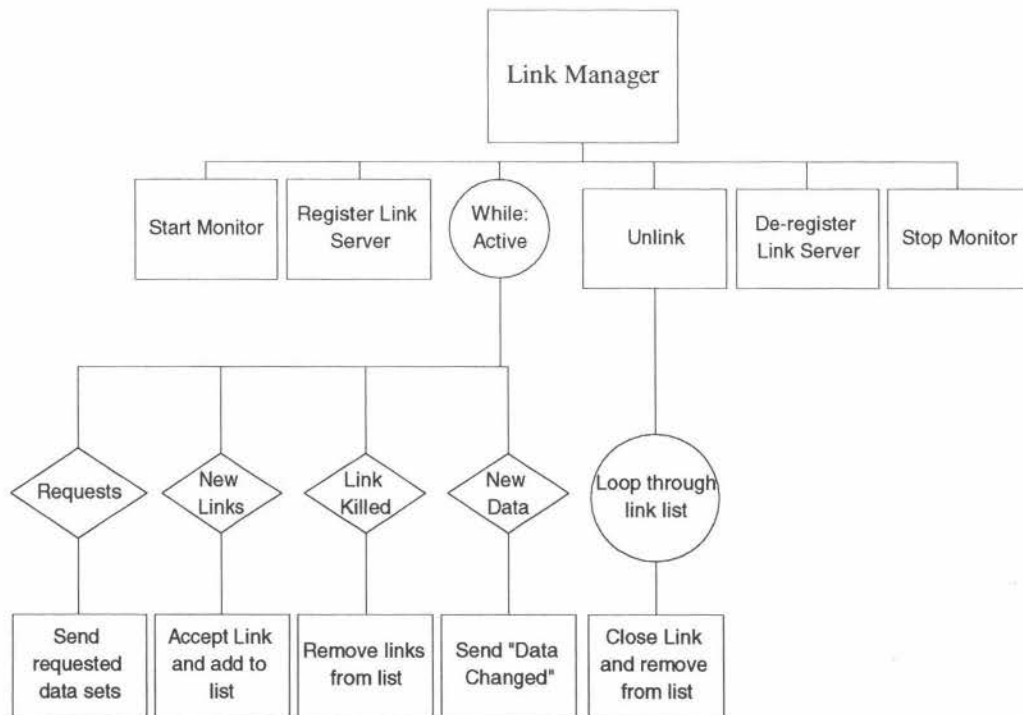

Figure 4-5: Link Manager Structure

4.4.2.1 Data Organisation

A TCP/IP server socket is kept open to listen for connections, and a linked list of server conversation sockets is used to communicate with each connected client.

This module transmits and receives data over the TCP/IP network using the custom data structure **PACKET**. This data structure has been developed previously for other applications used internally in *Forest Research*, and is adapted slightly for this project, while still being compatible with the previous applications. Although it provides more functionality than is strictly required for this project it is used to provide uniformity across in-house applications.

The structure is as follows:

Table 4-3: Packet Structure

Size	Name	Comment		
(Byte)	n	Handle length		
(Byte x n)	Handle	The name of the sender		
(2 byte integer)	Type	0=String,1=Picture,2=Binary		
		<i>String</i>	<i>Picture</i>	<i>Binary</i>
(4 byte long)	X	unused	Width	Number of Points
(4 byte long)	Y	unused	Height	1
(4 byte long)	Z	unused	Bits per pixel	Bytes per point
(2 byte integer)	nData	(length of data in bytes, max 8000)		
(2 byte integer)	cntdown	(number of packet in a series of packets, numbered (n-1) -> 0)		
(Byte x ndata)	Data			

When requesting data from the *Link Manager*, the *Analysis & Display* module sets the **Handle** to the name of the module, the **Type** to string, and the **Data** field to the name of the variable being requested. The *Link Manager* replies by sending back a packet with the **Handle** set to the name of the variable for clarification, the type set to binary, **X**, **Y** and **Z** set for the correct number of points of the correct value type size, and the data provided in the **Data** field. For example if the *Operator* client wants to know the current value of the feed speed it would send a packet with **Handle** set to "Operator", **Type** set to 0, and **Data** set to "FS". The *Link Manager* would reply with the **Handle** set to "FS", the **Type** set to 2, **X** set to 1, **Y** set to 1, **Z** set to 8 (the number of bytes in a double precision floating point number), **nData** set to 8 (1 x 1 x 8), and **Data** set to the byte representation of the value as a double.

4.4.3 Object Structure

The object hierarchy for the server side of the application is illustrated in Figure 4-6.

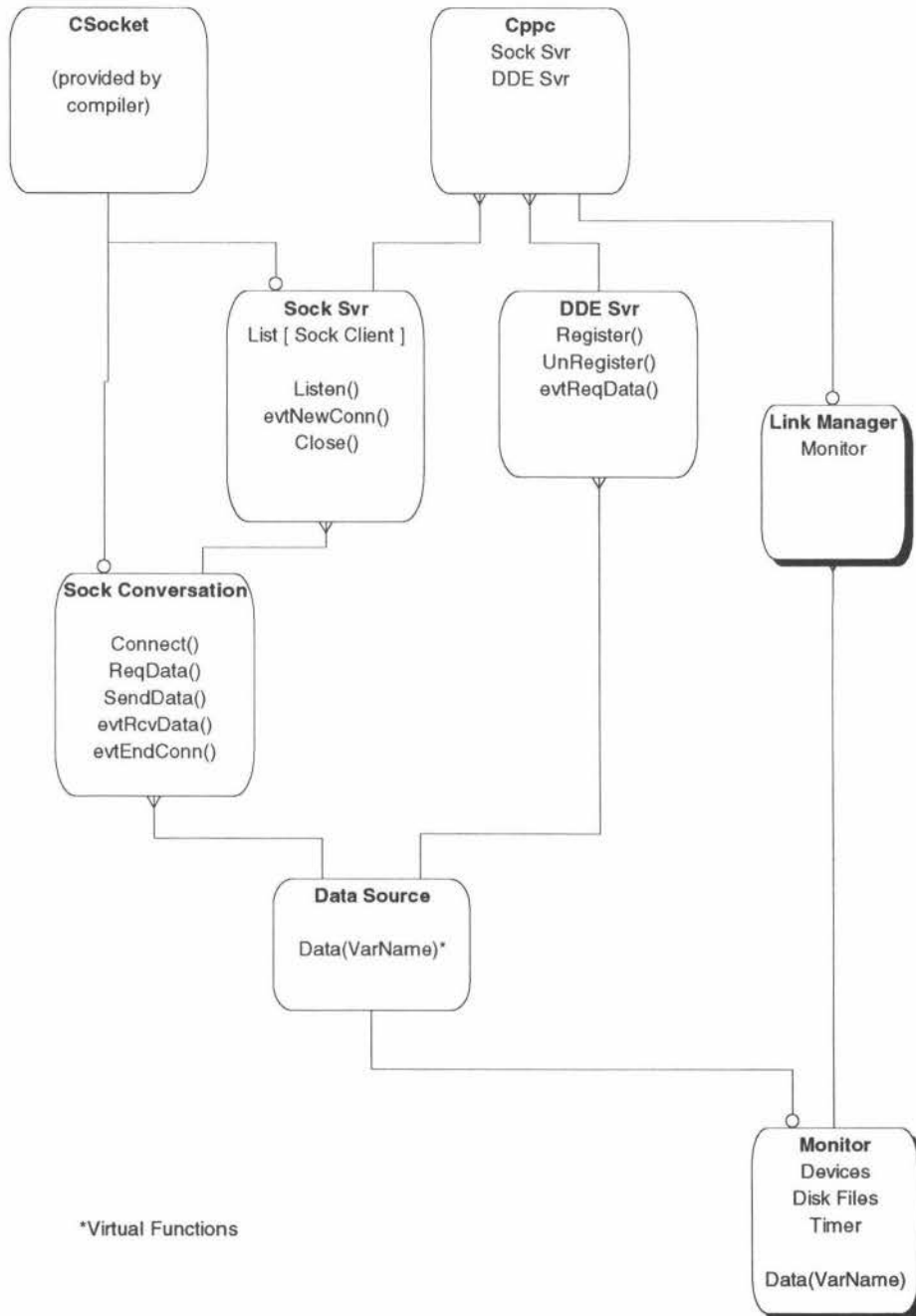

Figure 4-6: Server Object Hierarchy

A server socket derived from the standard Microsoft Foundation Class (MFC) *CSocket* is used to manage connections to the *Link Manager* by creating and destroying socket conversation objects. The conversation classes are also derived from the *CSocket* class but use the connection to pass data back and forth

with the connected clients. As a back-up in case of network failure, a Dynamic Data Exchange (DDE) server object is used to communicate with local clients. This protocol uses inter program communications provided by the Windows operating system.

Both of these server classes make up a Process to Process Communications (PPC) class, and use a generic Data Source abstract class as a template for getting information from the environment. This class is sub-classed into the final *Headrig Manager* object class, which uses the *Monitor* object as the sub-classed data source.

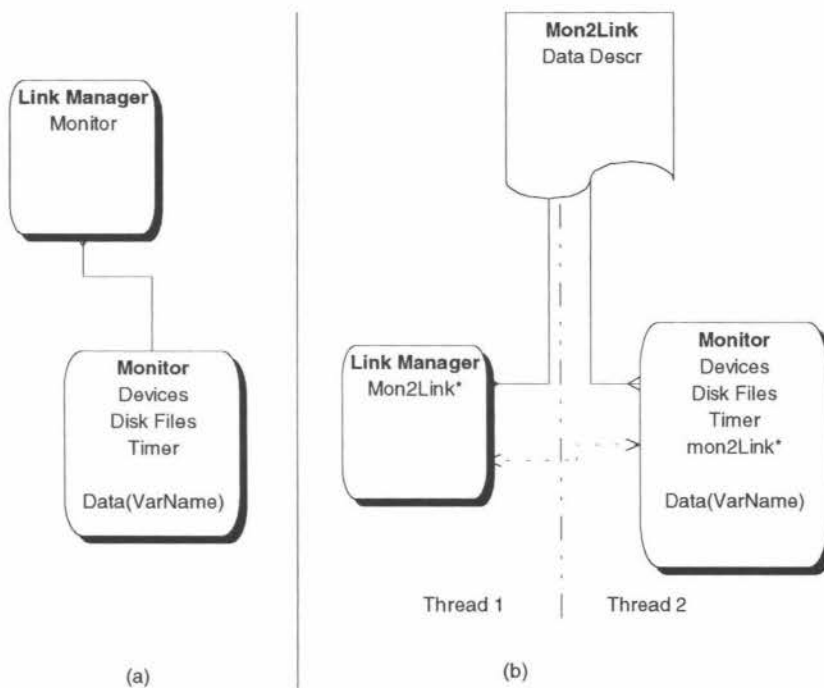
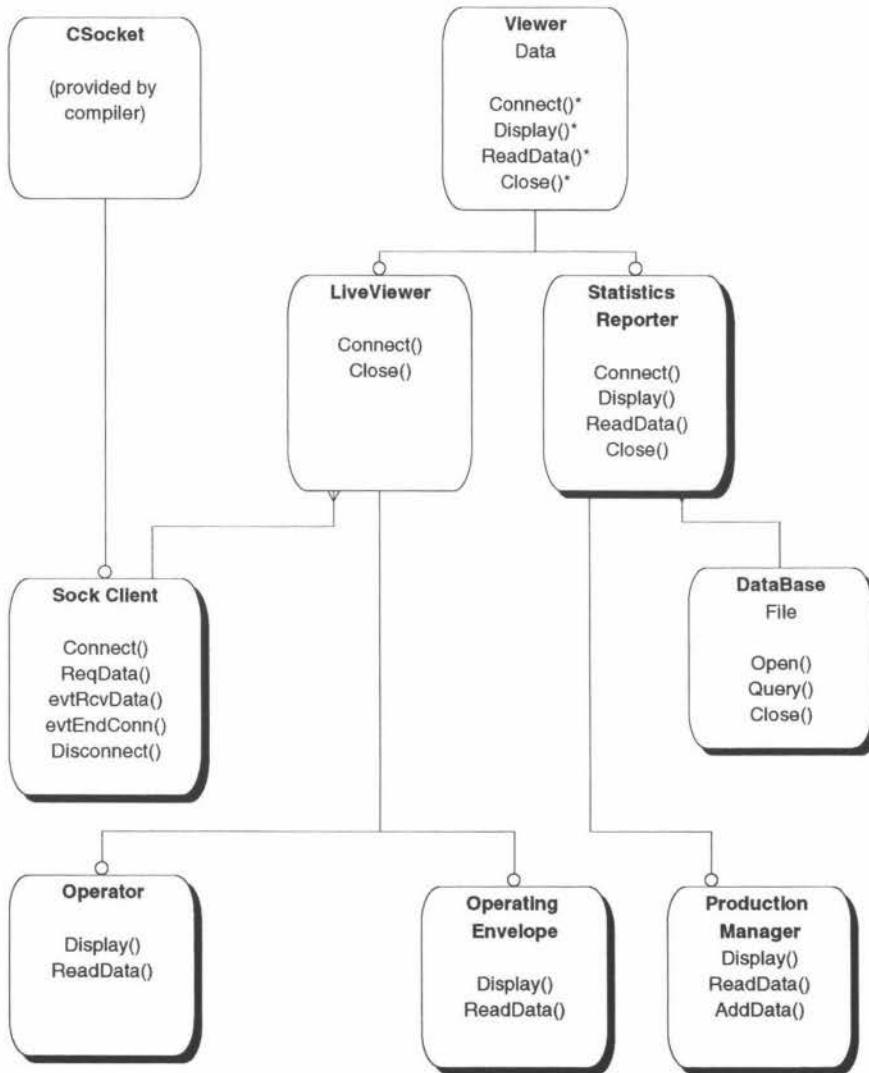

Figure 4-7: Alternate Architectural Links: a) Direct “has a” relationship b) Separate thread via data structure

Figure 4-7 illustrates alternative architectures for linking the *Monitor* and the *Link Manager* together. Scheme A depicts a conventional member ownership relationship where both objects exist in the same thread. This could lead to degradation of processing speed as both objects try to do a lot of I/O operations such as saving to disk or transmitting data over the network. Therefore scheme B was designed which separates the two objects into different threads with a joint data structure used to pass data, so that one thread isn't delayed while the other is performing a lot of I/O. This architecture is less robust and could be difficult to

maintain because the integrity of the data needs to be maintained by two independently operating processes. Through careful coding, the functionality of the *Link Manager* and *Monitor* are kept separate even though scheme A is used initially. This reduced the number of changes required to switch to the more complex scheme B as serious performance problems became apparent.

4.5 Client Software



*Virtual Functions

Figure 4-8: Analysis & Display object hierarchy (Client-Side)

The client software analyses the raw data once it has been collected and stored. Each client *Analysis & Display* module is written and compiled into a separate program, which provide a separate function to the user. Each client shows the

data in a slightly different way, but uses exactly the same interface for acquiring the data from the server. Four clients have been designed to provide a cross-section of the functionality of the system.

There are two different kinds of *Analysis & Display* modules: the live viewer and the statistics reporter. The differences illustrated in the object hierarchy shown in Figure 4-8 are that the live viewer gets the data directly from the *Link Manager*, analyses it immediately and displays the analysis to the user as the events happen. The statistics reporter gathers the information from the event database stored on disk by the *Monitor* and displays the analysis of the historical data to the user. The initially provided live viewer *Analysis & Display* modules are the Headrig Operator and Operating Envelope modules, and the initially provided statistics reporter modules are the general Statistics Reporter, with its subsidiary report generator, and the Production Manager modules.

The virtual functions defined in the *Viewer Data* object give the child objects a similar interface. The bodies of these functions are defined in each child object according to the particular analysis or display function.

4.5.1 Headrig Operator

This display shows a diagram of the headrig with instantaneous read-outs of the blade displacement, top wheel position, feedspeed, and log diameters in the appropriate places (see Figure 4-9).

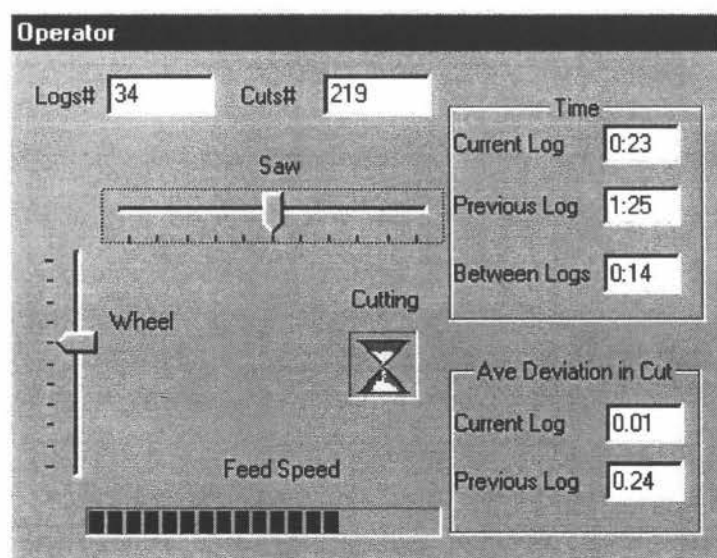

Figure 4-9: Operator Display

This shows to the operator during cutting the current feed speed, wheel position and blade position. If either of these variables exceed pre-determined limits the operator can adjust the feed speed accordingly. At the end of each cut, the average feed speed, average and standard deviation of the blade displacement and top wheel displacement are displayed along with the number of times the blade moved out of pre-defined limits. The success of this module shows the capability of the system to display real-time data.

4.5.2 Operating Envelope

An instantaneous dynamic operating envelope is displayed as described in Figure 4-11. The current feed speed and Depth of Cut, as interpolated from the two end diameters recorded by the log scanner and provided through the *Jaymor Flight Recorder*, are shown as a point on the screen in the context of the relevant operating envelope, which will be calculated from a set-up dialog.

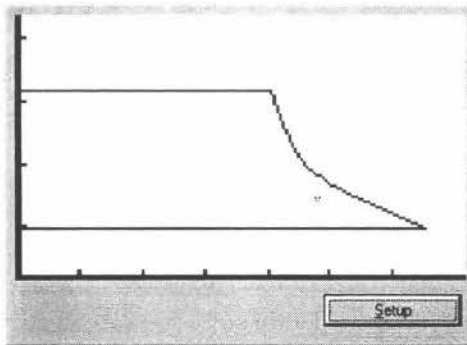

Figure 4-11: Operating Envelope

Parameter	Value	Unit
Pitch	50	mm
Plate Thickness	2.42	mm
Tooth Width	2.54	mm
Gullet Capacity	555	sq.mm
Motor Speed	725	rpm
Motor Pulley Diameter	320	mm
Bandsaw Pulley Diameter	300	mm
Blade Speed	322.4	m/s
Bandsaw Wheel Diameter	2300	mm
GFI	0.7	0-1
Spillage Factor	0.2	0-1

Figure 4-10: Operating Envelope Setup Dialog

The operating envelope shows the operator in real-time where the machine is running in the current operating envelope. The operator can adjust the current operation point to the optimal position, which is just inside the envelope, by adjusting the feedspeed. The success of this module shows the ability of the system to perform analysis on real-time data in a timely fashion.

4.5.3 Statistics Reporter

The statistics reporter module generates reports using a database engine for a specified period of time (see Figure 4-12). The content of the report is determined using a tag-based system similar to HTML, and can be designed by any user to achieve maximum flexibility (see Figure 4-13).

The event types available are listed in section 4.4.1.1. The structure of the report templates (*.rpt) are a simple text file with the tags listed on separate lines as follows:

Listing of Operator.rpt:

```
Title=Operator
<#Logs>
<#Cuts>
<Log Type>
<Cut Time>
<Down Time>
<Log Setup Time>
<Ave Saw>
<SD Saw>
<Ave FS>
<SD FS>
<Vol In>
<Vol Out>
<Conversion>
```

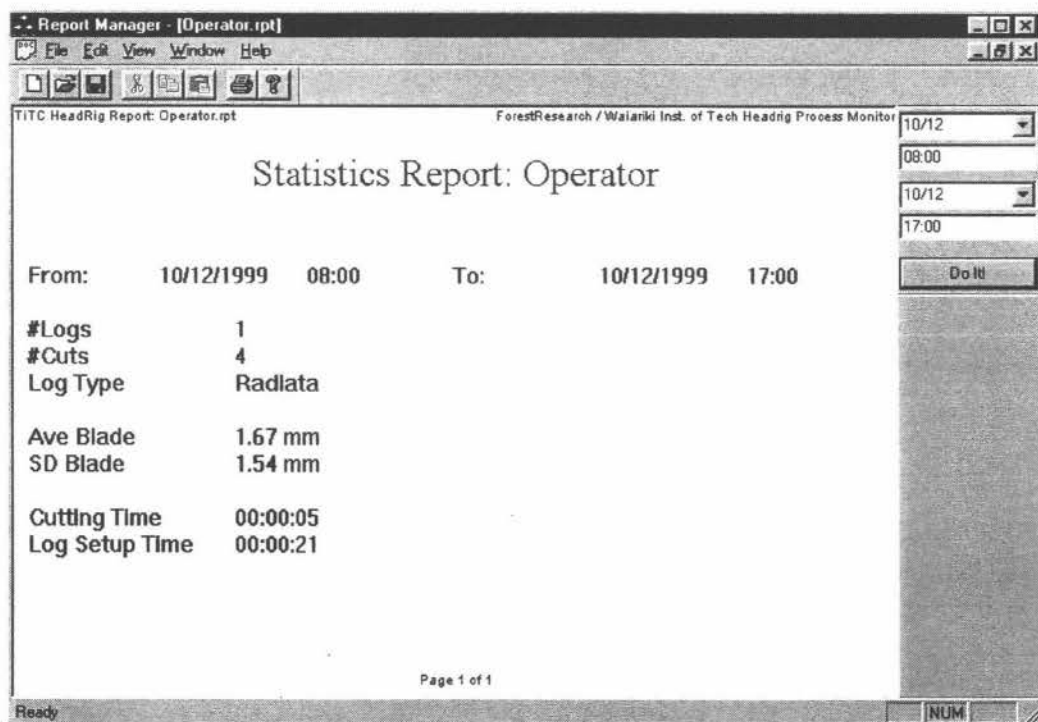

Figure 4-12: Sample Statistics Report

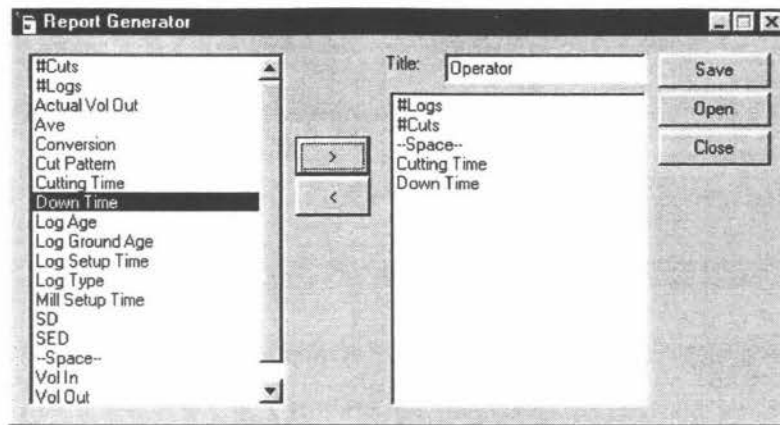

Figure 4-13: Report Generator Screen

The purpose of the statistics report module is to provide both the mill manager and researchers in long-term experiments with operational data for given periods. An example of this use would be a monthly production report for a manager, or data for an investigation into the effects of wear on production for a new saw material. The success of this module shows the database capabilities of the system for storing and retrieving historical data.

4.5.4 Production Manager

This is an extension of the statistics display module, and will be used for both teaching and for running the commercial mill. The `ReadData()` and `Display()` methods are overridden.

Statistics are displayed of the supply of logs broken down by log class and age-on-ground, the costs involved in the running of the headrig machine featuring the saw usage, and the pieces produced from the machine. It can be assumed that the downstream processing of the slabs into final products is performed ideally, or alternatively the tally from the green table can be entered manually to calculate conversion statistics. The log type, log age and cut pattern for the upcoming period can be entered in this module, and this module only.

4.6 Summary

The process information program is designed using a client-server software architecture to provide maximum flexibility and scalability for future modifications. The central server is designed to gather the process data, scale

and format it, and store it locally on disk. The data is distributed live across the local area network through a TCP/IP socket based Link Manager, with a Dynamic Data Exchange (DDE) communications provided in case of network failure.

A number of clients are initially available that provide both live process information displays and statistics for information gathered over time. An *Operator* and an *Operating Envelope* module are provided that show information about the process as it happens. A *Statistics Reporter* module provides historical analysis of the data stored on disk by the server, and a *Production Manager* module enables information that is not captured automatically, such as log types, to be entered into the database in a consistent manner.

Development of a Headrig Process Information System

5. Experiment: Effect of Wood Density

5.1 Introduction

To demonstrate the effectiveness of the system developed in the previous chapters, an experiment has been designed to show how such a process monitoring system can address an important issue in the wood-processing sector. This major issue is the effect of wood density on the quality of the final product.

Density affects the wood processing sector in many ways. In logistics, raw materials are often purchased by weight, but the product is often sold by volume. A lower density enables the sawmiller to get more product for the same raw material price. The strong relationship between density and stiffness also makes density an important factor. Stiffness is becoming recognised as a very important wood quality feature. In fact, there is a new building standard (Gaunt, 1998) being produced in New Zealand that uses stiffness as the overriding characteristic in determining timber grades, and therefore prices.

However, it is not known in any great detail what effect stiffness, and its surrogate density, has on the process of manufacturing wood-based goods and how the process can be tailored to take advantage of any density related effects. It was suggested by the sawmill manager that the measurement of the effect that density has on the sawing process would be of use.

5.2 Experiment Objectives

With the scope of the process information system in mind, the experiment has been limited to the following:

1. To determine the effect of average log density on the process at a headrig bandsaw.
2. To determine the effect of wood density on the process at a headrig bandsaw.

5.3 Methods and Materials

The process information system developed in the previous chapters was used to gather data from devices mounted on the headrig bandsaw.

The data for this experiment was gathered during a trial that *Forest Research* performed as a commercial contract to a customer. The trial consisted of 24

radiata pine logs from a certain forestry plot in the North Island that contained the set of characteristics that the client specified. This site was known to generally produce low-density wood, but was expected to still provide enough variability in density for this study. All the logs were butt logs (the first log from the ground) that were completely pruned, providing mostly large logs with a large number of cuts per log. Eleven logs were chosen with regular features and representing a range of density values.

Log density was measured using the Pilodyn instrument, which measures penetration depth of a rod pushed into the log with a consistent force. This is a relative measure of density, and can only be related to absolute density by laboratory analysis of the wood. Pilodyn readings were used to define the range of density in the data set.

The cutting patterns for this trial were designed to provide a wide range of differently sized material. Figure 5-1 illustrates the general pattern for cutting a log in a counter-clockwise direction. Each set of cuts is executed until it reaches a set distance from the centre of the log, and the then log is rotated 90°. This produces boards that get progressively narrower with each turn. To get a wide range of sizes the thickness of the boards that were cut was also changed at each 90° turn. Each round-back board produced (the first board cut from each orientation) is given a flat outside face with a chipper head.

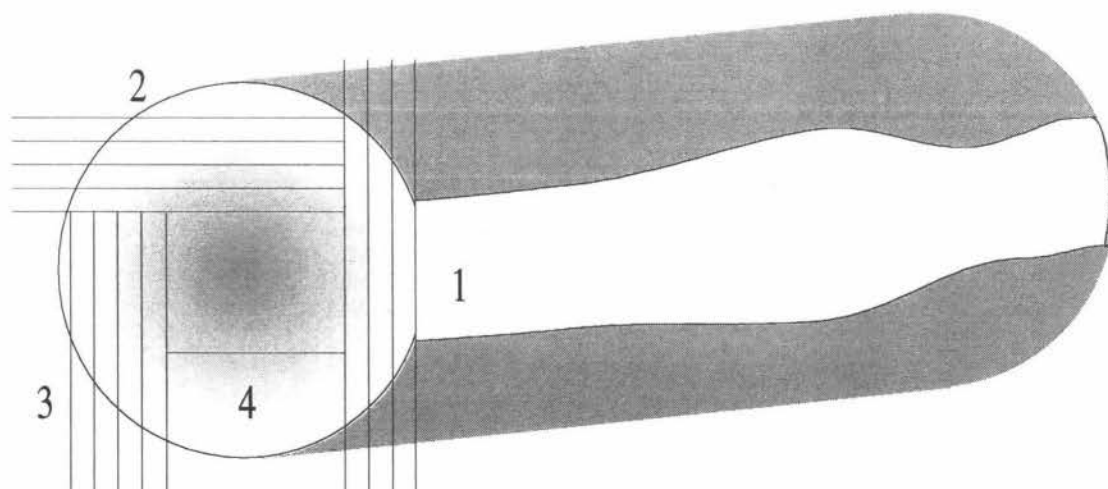

Figure 5-1: General cutting pattern

5.4 Results

5.4.1 Density

The sizes and densities of the log set are shown in Table 5-1.

Table 5-1: Log sizes and densities

Log Identifier	Small End Diameter (mm)	Pilodyn Penetration (mm)
A	430	13.75
B	400	14.00
C	380	15.00
D	430	15.00
E	425	15.25
F	570	15.50
G	440	15.75
H	390	16.00
I	540	16.50
J	470	17.00
K	460	17.50

5.4.2 Cutting Patterns

The cutting patterns for the logs relevant to this study are described in the following set of diagrams:

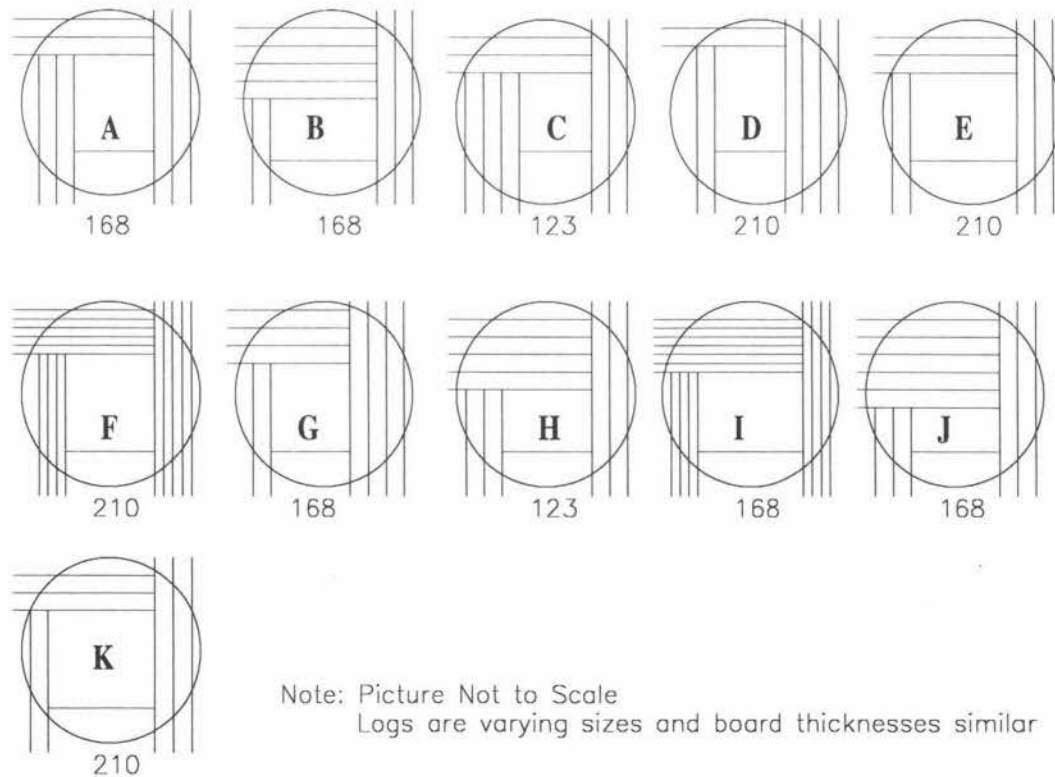

Figure 5-2: Specific cutting patterns used

The cutting order as displayed in Figure 5-2, is right-first, then top, left and bottom, respectively, as in the general cutting pattern. The vertical and horizontal lines show the number of cuts in each set. The letters inside each log-end is the identifier for that log and the numbers below indicate the width of the remaining cant in millimetres.

5.4.3 Process Indicators

The movement of the blade in a lateral direction and the vertical movement of the top band-wheel were used as the indicators of performance. Blade movement affects the thickness variation of the product directly, whereas the wheel movement is indicates action in the strain system that attempts to keep the blade under constant tension. The strain system's pneumatics also has the effect of dampening any oscillations caused by a change in the log's resistance to being cut. Blade speed is set at a constant rate.

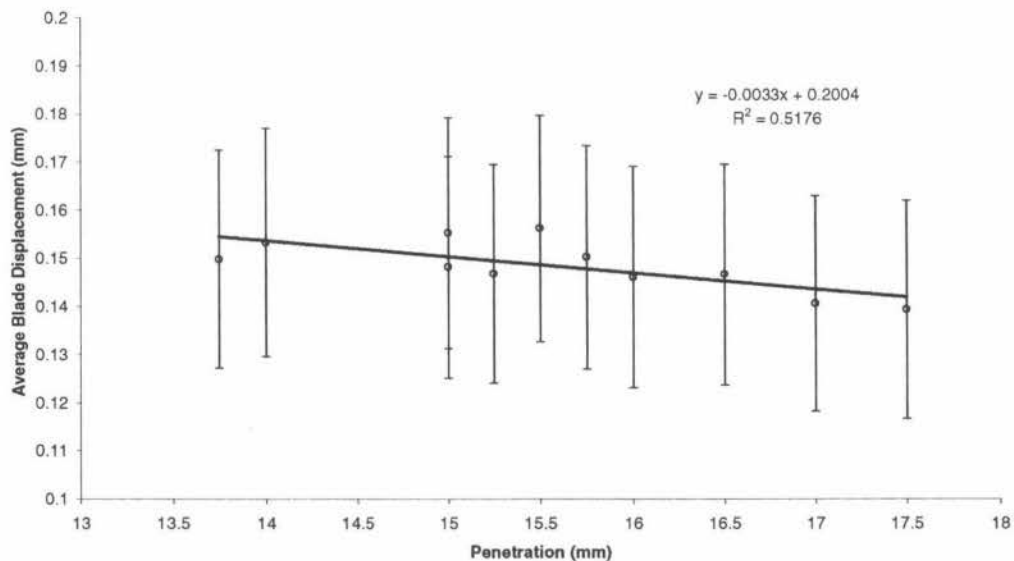

Figure 5-3 : Effect of density on lateral blade position

Figure 5-3 shows the average blade position throughout the cutting time for a log, with range limits as defined by ± 2 standard deviations. Negative positions are impossible, as this signifies the blade cutting into the sensor.

A similar graph showing the position of the top band wheel is shown in Figure 5-4. The ranges shown are defined as ± 2 standard deviations of the data about the mean.

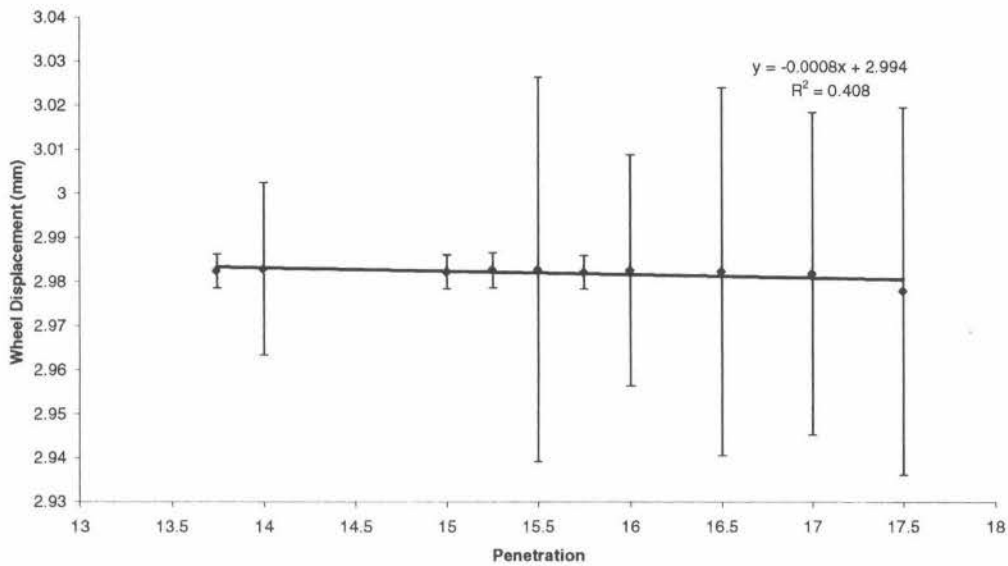

Figure 5-4: Effect of density on top band wheel position

5.5 Discussion

Although there appears to be a trend of less blade deviation with decreasing density, this is masked by the significant within log variation. The results from this are therefore inconclusive without relating the individual measurements to the specific wood densities encountered by each cut.

'Spiking' was unexpectedly found to be a large magnitude contributor to the variation of the wheel position. The spikes produced in the position recorded by the LVDT (Figure 5-5) are thought to be produced by the blade encountering high-density knots, which in turn changes the downward force on the wheel which then compensates to keep the blade tension constant. As the force change completes the wheel returns to the home position and dampens any oscillations in the blade due to the sudden change. This behaviour is somewhat different to the usual behaviour of bandsaws in New Zealand mills. Generally, in other mills the blade would move as it hits a knot and start to vibrate. The bandwheel dampening mechanism would then react to try to reduce the vibration and to restore the blade tension to its previous value. The difference with this machine is that it is only 5 years old, much newer than most machines in New Zealand, and responds so much more quickly that the spiking is the only evidence that a knot has been encountered.

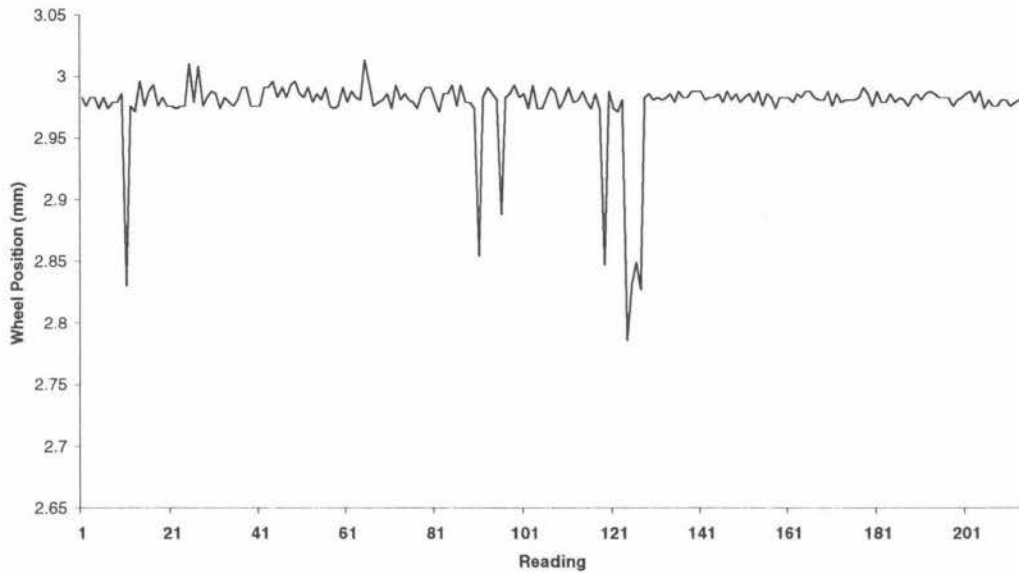

Figure 5-5: Example of 'spiking' - Log F, cut 2

There is a correlation between the density of the log and the number of spikes produced in the wheel movement in the log set, with an R^2 of 0.63 (see Figure 5-6). The exception to this is log F with nine spikes, which is treated as an outlier when calculating the correlation.

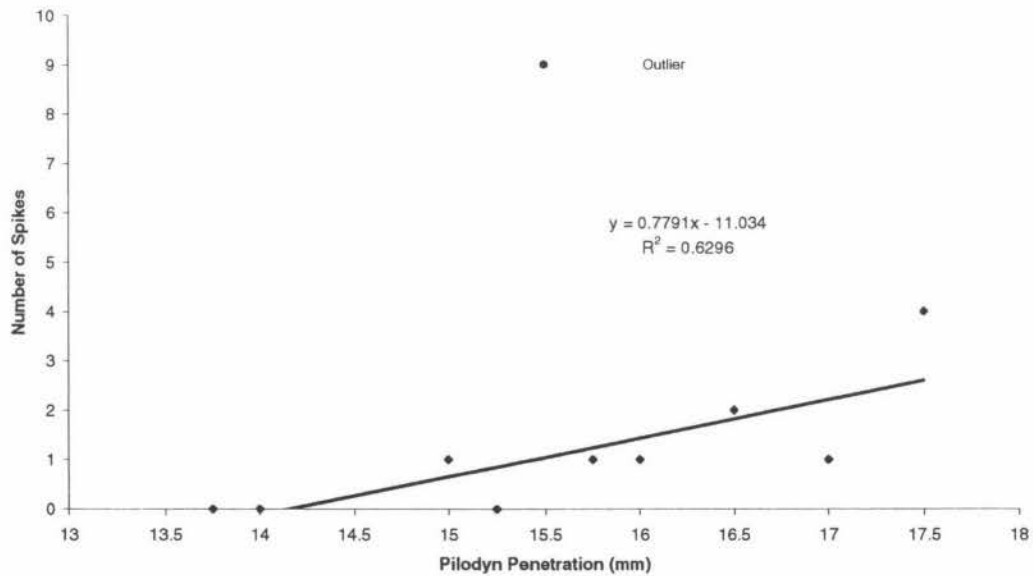

Figure 5-6: Effect of density on 'spiking'

When the points associated with these spikes are removed from the wheel position data the density correlation is reduced to an R^2 of 0.0004 (see Figure 5-7). This implies that the spikes cause the majority of the movement, and the remainder is low-amplitude random noise.

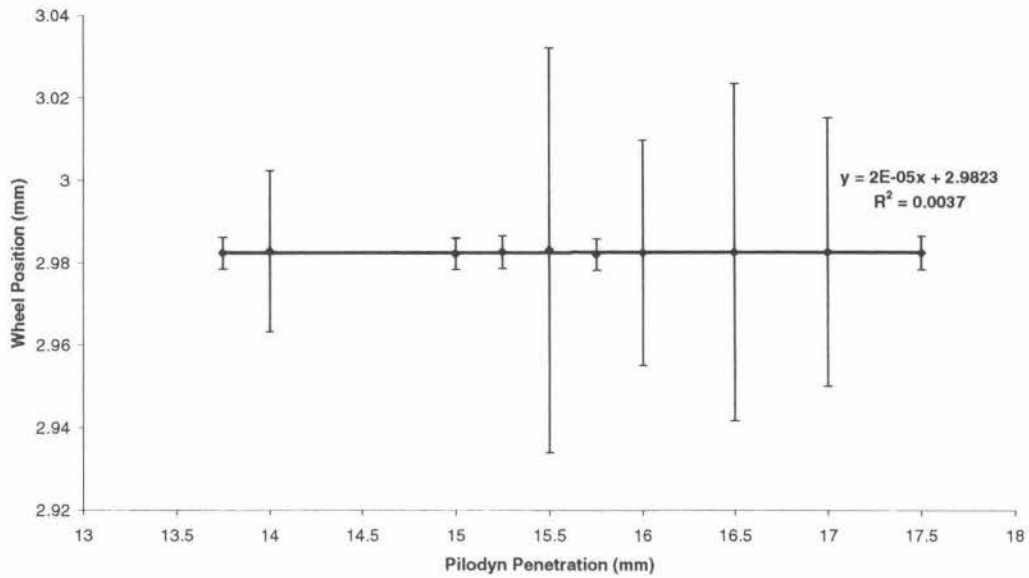

Figure 5-7: Adjusted effect of density on wheel position

5.5.1 Log-Based Effects

The bias and spread of data related to the blade movement for each log showed an insignificant difference between logs (see Figure 5-3).

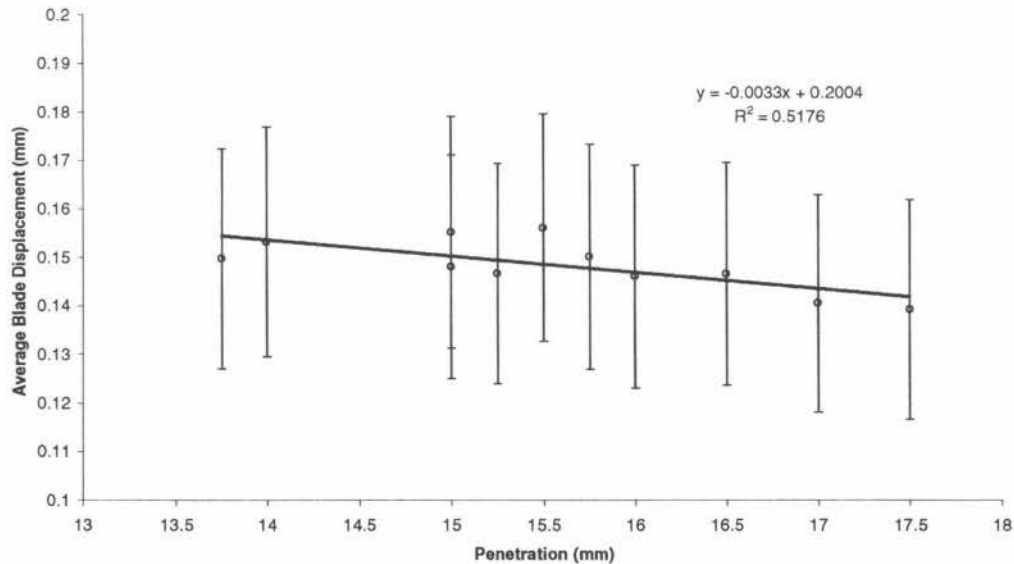

Figure 5-8: Effect of density on blade movement

While the higher density logs (less Pilodyn penetration) tend to have smaller deviation in wheel movement, there is not a significant linear correlation (see Figure 5-9) with the R^2 coefficient only 0.09.

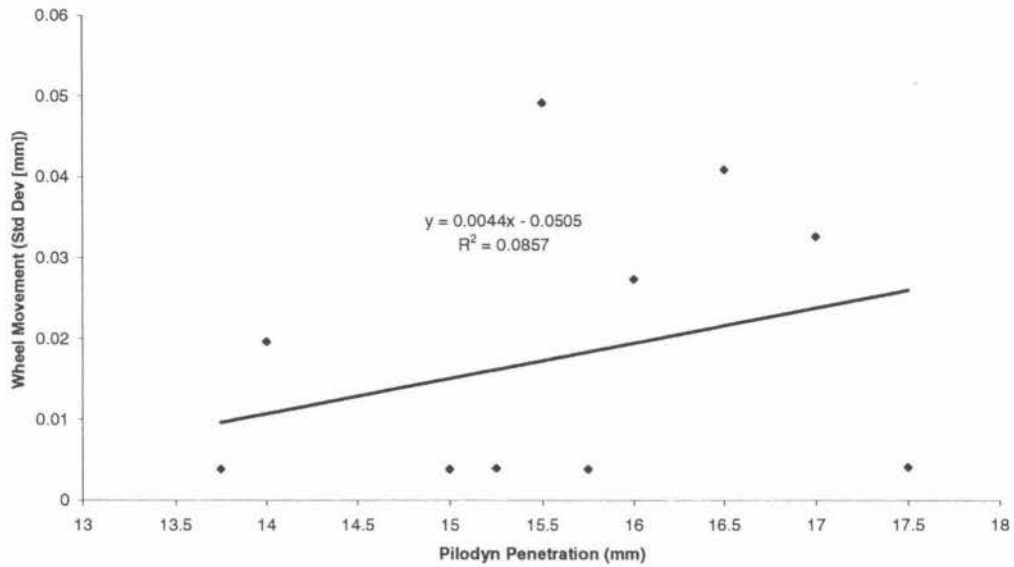

Figure 5-9: Effect of density on wheel movement

5.5.2 Cut Position Based Effects

Figure 5-10 shows the blade bias data that is re-organised so that it is ordered by cut number. The error bars show ± 2 standard deviations of the blade movement during cutting. There is no trend relating either bias or variation to the distance from the log surface, and therefore the average wood density.

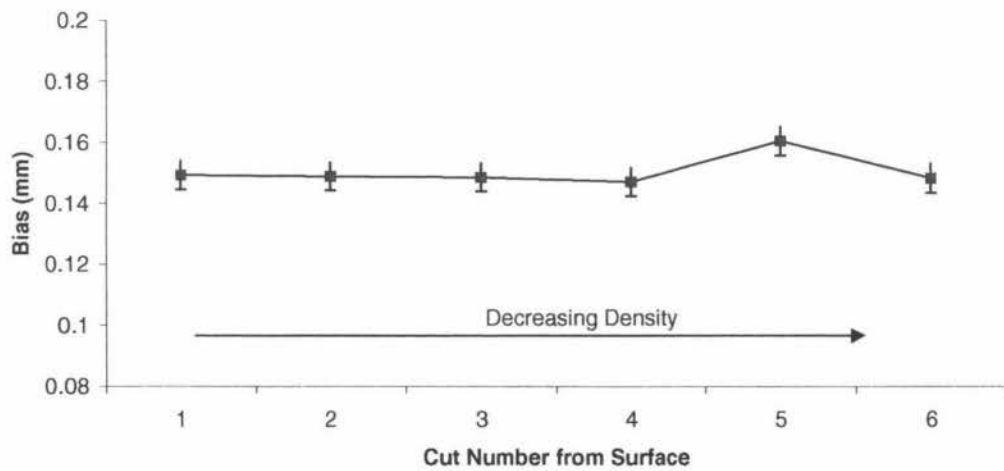

Figure 5-10: Blade Bias by Cut Number

There is also no apparent trend in the wheel position according to cut number, as is seen in Figure 5-11.

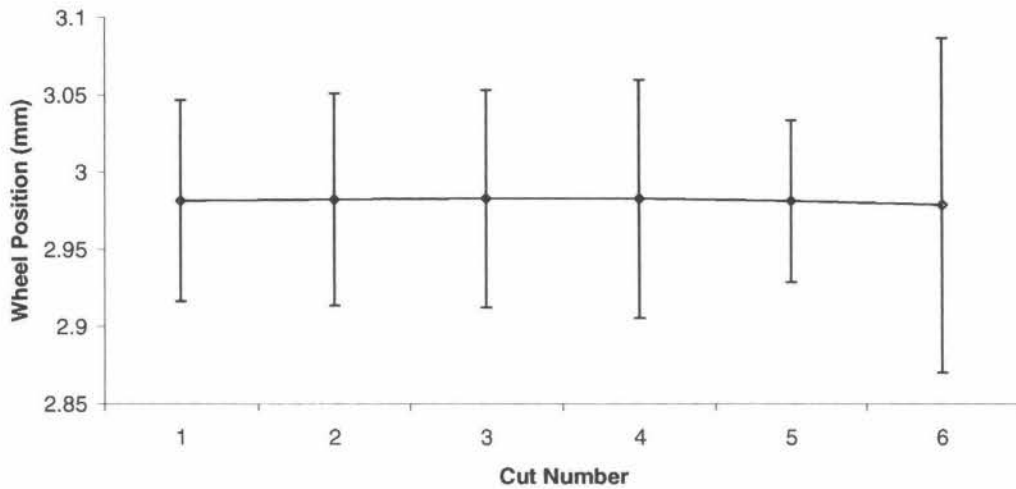

Figure 5-11: Wheel Position by Cut Number

There is a slight trend in increasing movement with decreasing average wood density, with the exception of cut number 5 (Figure 5-12), but as with the log-based effect the R^2 value of 0.25 is very low.

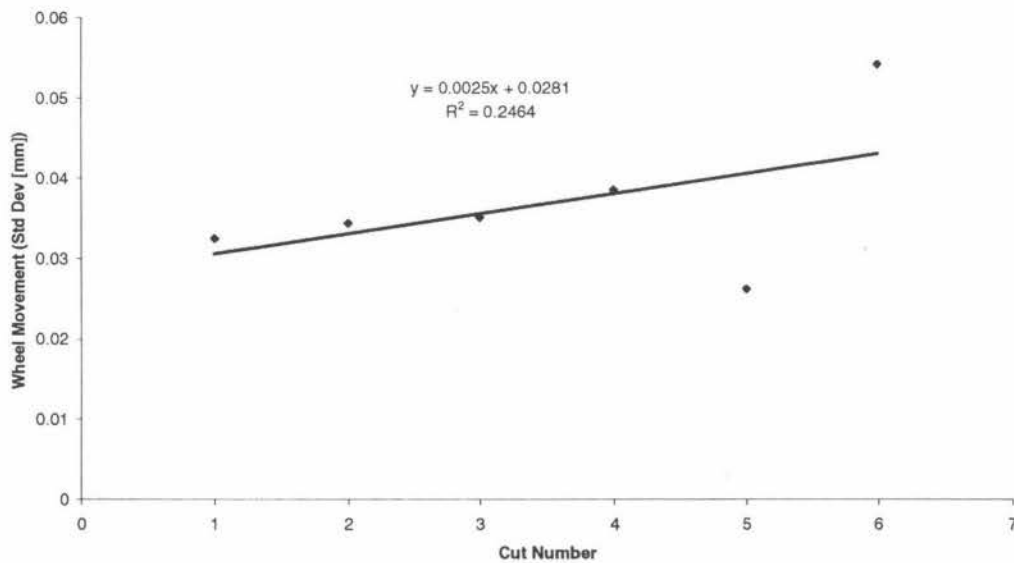

Figure 5-12: Wheel movement by cut number

5.6 Conclusions

There was no significant relationship between density and either blade position or movement, or wheel position and movement in the range of logs used in this trial. Any trends within the data are masked by the significant variability of within the measurements. To investigate these trends further, it would be necessary to measure the actual density at each cut, rather than on a by log basis.

The correlation of density, as measured by pilodyn penetration and spiking of the wheel position was calculated with an R^2 of 0.63. The spiking is thought to be caused by the blade striking a knot causing a change in vertical force on the top wheel. The strain mechanism on the top wheel responds quickly to keep the tension on the blade constant, and is so successful that the effect is totally compensated for before it can translate into lateral movement of the blade. This is a good example of new technology having a positive impact on the sawing process. The correlation causing more movement in the less dense logs could be due to the higher contrast between the very high-density knots and the less dense wood.

It is recommended that a similar study be constructed that will determine if the spiking effect is caused by knots. The study would also record the longitudinal positions of the branch whorls visible on the outside of the log. The positions can then be correlated with the longitudinal positions of the spikes. If the study proves successful then the new technology has effectively eliminated the effect of knots on the sawn product dimensions.

A full analysis of the effectiveness of the system to produce the data for these results is given in the next chapter.

Development of a Headrig Process Information System

6. System Evaluation

6.1 Function

Throughout the experiment described in the previous chapter, the system provided all the basic functionality required to operate. Data was collected and stored faultlessly for a week of continuous operation, and data was transmitted to the client *Analysis & Display* modules.

The system performed 100% of the core functions required to run the server effectively, and 70% of the total functionality required for the experiment (see Table 6-1). The functions were given subjective ratings according to how crucial the task is to the study, and how difficult the task would be given the previous task is completed.

Table 6-1: Functionality provided by system

Task	Function Rating	Provided	
Server	Collect Data	15%	Y
	Store Data on disk	15%	Y
	Communicate data to clients	15%	Y
Client	Show cut in real time	10%	Y
	Calculate backstands ⁵	5%	Y
	Calculate cut statistics	5%	Y
	Calculate log statistics	5%	Y
	Reorganise data by cut number	10%	N
	Calculate statistics by cut number	5%	N
	Produce Graphs	15%	N
	100%	70%	

All the data required was gathered and stored in a readily retrievable form but the *Analysis & Display* module provided for log studies was unable to perform all the required analyses. The module was designed to give averages, standard deviations, and peak values for each cut within a log which was then compiled to give log statistics. This information was very useful for looking at the effect of log density on the process, and provided all the information required for this part of the study except individual cut plots.

⁵ A backstand is the distance from the back-plate of the log holding mechanism to the cutting line.

However, it did not provide information about the data as distributed across logs, rather than within-log data. To evaluate the effect of wood density as determined by the cut distance from the log surface, data from all the logs needed to be re-organised into cut number groups, irrespective of which log the cut was from. Such analysis was performed using a spreadsheet instead. The use of a spreadsheet to graph individual plots and re-organise the data into cut groups is not necessarily detrimental to the system's overall performance. While common groupings of data, such as per log, can be done efficiently using the in-built system, more complicated or varied manipulations could be better served using a package such as a spreadsheet which is well designed for the job.

This is a vast improvement over previous techniques used by *Forest Research* in the mill. A portable monitoring unit, which was the standard previously, simply collected the data and stored it into a disk file. Using the same rating system this would provide only 30% functionality required for the experiment.

The spiking phenomenon found in the analysis of the experimental results is a process variable that may be added to the client software. A measure of the size, length, and frequency of spikes would provide an indication of a new variable that seems to be pivotal to the operation of this particular machine station.

6.2 Reliability

The complete system is extremely reliable. The system was tested for a complete working week, without any breaks, and the system did not crash once. This more than meets the minimum requirement to run throughout one working day without crashing. The reliability of the system is, however, dependent on the stability of the Windows NT operating system. Keeping the server machine as a dedicated machine, running no other software, aids this stability.

Connection to the server by a client *Analysis & Display* module was refused only once during the week. This was due to a long disk-queue waiting period of over a second in the operating system caused by both the *Jaymor Flight Recorder* and the *Monitor* accessing the disk at the same time. The single refusal of a connection to the server due to the operating system delay does not seem to be a problem currently. Once refused, the module tried again and immediately was

accepted. However, if many modules are used concurrently over the network, the increase in work-load could lead to unacceptable delays in data collection. This will need to be periodically monitored to determine the frequency of this problem, and further tailor the communications to suit.

The top wheel movement measurements were invalidated for two isolated working periods, of approximately two hours each, due to the device being reset incorrectly by the sawdoctors after a sawchange. This indicates a weak spot in the physical layout. The LVDT was originally designed to go between the strain force mechanism and the damping mechanism. However, upon further investigation, the modern design of the system incorporated the two elements into a single sealed cylinder. The LVDT is therefore mounted under the wheel axle on the side of the housing. Because the wheel moves to different heights when strained due to different amounts of stretch in the blade, the LVDT has to be reset to a different base height at each sawchange. A new mounting which clearly indicates the mid-point of the LVDTs range may have to be designed in future.

6.3 Modularity

The software system is extremely modular. The *Monitor* and *Link Manager* comprise one program file, and each *Analysis & Display* module is kept in a separate executable file.

The hardware is physically connected to the computer system either through the *Jaymor Flight Recorder*, which is configurable by Jaymor at any time, or through a National Instruments general data acquisition (DAQ) board. The system modularity allows both the hardware and the software to be easily extended or modified. Each physical device can be connected either through the DAQ board or the *Flight Recorder* to the server without rebooting the software system. This is perhaps the strongest advantage this system has over any commercially available system. Each channel of information from the devices is tagged through the use of Windows initialisation files. The channel is thereby named, scaled and made available by the server by name. Once registered with the server, any *Analysis & Display* module may request the associated data for the channel.

New *Analysis & Display* modules may be written by sub-classing the client objects provided, or alternatively writing new modules that implement the TCP/IP links with the *Link Manager*. An effect of the software architecture is that the *Analysis & Display* routines can be written in any language that includes TCP/IP communications.

This modularity greatly simplified the gathering and analysis of the experimental data. By being able to choose only the variables of interest no extra filtering of the data was required. Also by showing the data in a manner that conveyed information directly relating to the experimental problem, conclusions could be made about the results immediately.

6.4 System Response

The response time is measured from the time an *Analysis & Display* module requests a data point to the time the module receive the data value. The variability in the response rate is a side effect of using a network protocol such as TCP/IP that has an undetermined response time between server and client. As part of the week long reliability test a client connected to the server once every hour of the working day, requested a value, and recorded the time it took to receive the value (see Figure 6-1). As the server was running in a completely operational mode the value was copied directly from the data acquisition card's buffer, as it would under normal operating conditions.

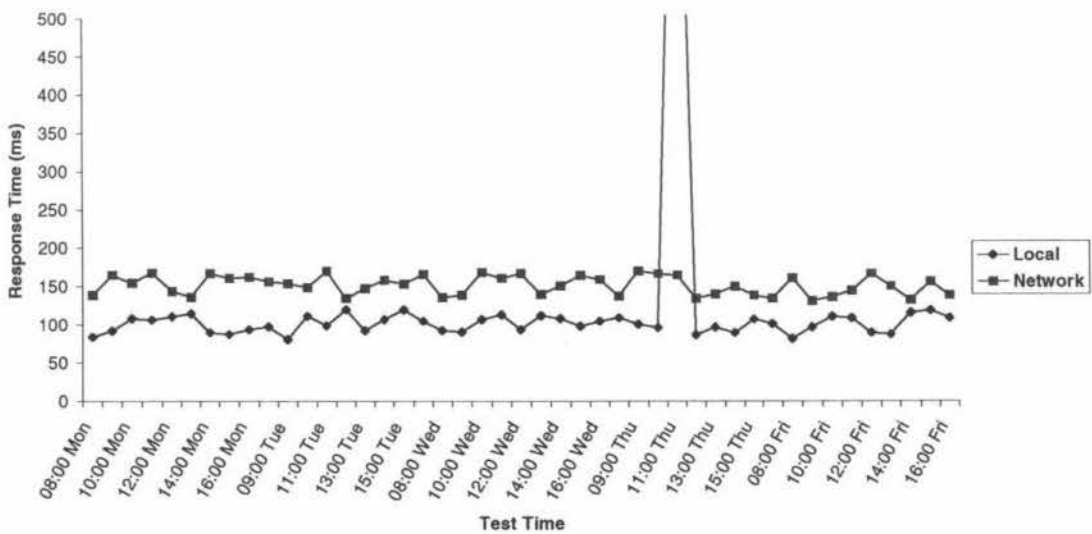

Figure 6-1: Response Times

If the client is running on the local machine then an average response rate for a channel value is 100ms and 150ms if the client is across the network. The spike shown at 11:00 on Thursday indicates the single connection refusal described in the Reliability section above.

The number of clients running at the time also affects the response time. Several clients were activated in turn that continuously requested data points from the server. The response time recording client the recorded ten response times per loading step (see Figure 6-2). The response time degraded from 100ms for 1 client (the response time recording client) to 200ms for 10 clients.

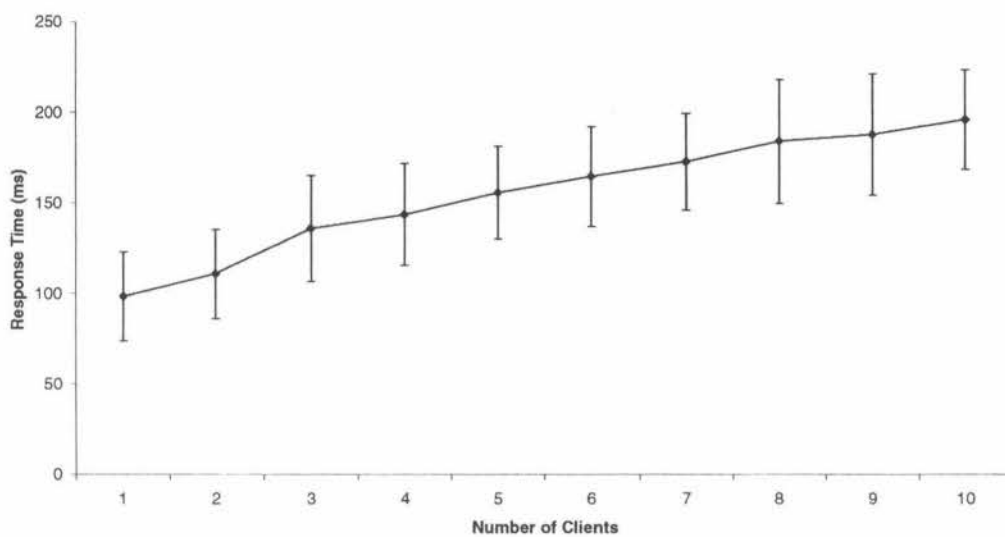

Figure 6-2: Response degradation due to client loading

The response time is negligible when it is compared to time it takes to make a cut, which is about 8 seconds. Also the reaction time of the operator would be much higher than the response time of the system.

6.5 Conclusion

Only minor modifications may need to be completed before the system is functioning at its optimum, such as making the process of resetting the LVDT easier, and streamlining the server to handle peak loads. As it is, the system is 100% operational, fulfilling all the criteria outlined in chapter 2.

All of the data required to complete the experiment that was detailed in the previous chapter was provided through the completed system. Some of the analysis was performed using spreadsheets, but 70% of the work required for

collection, analysis and presentation of the information was completed directly by the system. This is a good mix of operations where a niche has been filled without 're-inventing the wheel' in trying to imitate the function of a spreadsheet. It is an improvement of 40% on previous methods. Adding a variable to the *Analysis & Display* client that provides information about spiking, as described in the experiment chapter, would further increase the usefulness of the module.

A response time of 100ms to 200ms should be more than adequate in most cases. When compared to the time it takes to make a cut (typically about 8 seconds), and the reaction time of the operator, the time is negligible. This time is mostly due to the transport and I/O operations performed, rather than the number of points copied from memory space to memory space, and so the time does not appreciably rise when communicating a set of points. This property is used to reduce the peak loading at the end of each cut. The data for an entire cut is communicated just as easily as the instantaneous position of a sensor, allowing the clients that update data at the end of each cut to only request data once for each variable, rather than for each point.

Development of a Headrig Process Information System

7. Conclusion

7.1 Major Points

The project was successful in producing a working process information system for the headrig machine station, and provides a good template for expanding into the rest of the sawmill.

The system demonstrated real-time capability in providing information to the operator in order to make processing decisions. This is a good example of new technology helping sawmillers to make better processing decisions, and therefore better produce a better product mix. A response time of 100-150ms can be considered real-time when providing on-screen information for an operator, but may not be adequate for direct feedback control, which is the next logical step. Any direct control may require a process in parallel with the *Monitor*, which would require an architectural change, or further development of the efficiency of the transport mechanism.

The high modularity of the data acquisition hardware allows sensors to be added or removed without restarting the system making it easily extendable to new sensor technologies. The loose coupling of the data collection server with the data analysis clients enables clients to be added and removed from the system without affecting core performance, or even restarting any of the server's processes. Also using network protocols allows the clients to run on a completely separate machine.

An advantage of the software architecture is that the *Analysis & Display* routines can be written in any language that includes TCP/IP or DDE communications. It was highlighted in the experiment that not all of the processing is necessarily best performed by custom-made programmed modules. Spreadsheets, and similar methods, may still provide one of the best techniques for particular off-line analyses. It is even plausible to use a spreadsheet as a client directly using a DDE link and pre-made templates.

Another point that was highlighted in the experiment is that the sensors used must be checked for proper realignment before starting a shift. This is particularly pertinent if large adjustments are necessary, such as with the LVDT mounted on the top bandwheel of the headrig.

7.2 Future Directions

Lessons learned from this project will be used to help the overall programme in building a facility-wide information system. A factor that was highlighted in this project is the degradation of response times due to client loading. This could become more important as the system size and complexity increases. However, the use of the client server model does make the system scalable in terms of structure. A system of servers, one server per machine centre, would be simple to construct using this project as a model for the other centres.

The other machines in the sawmill which are candidates for instrumenting are the circular gang saw, which cuts the slabs from the headrig into a set of boards in one pass, and the band resaw, which is similar to the headrig only smaller for cutting the cants into boards. The machines are arranged as in Figure 7-1.

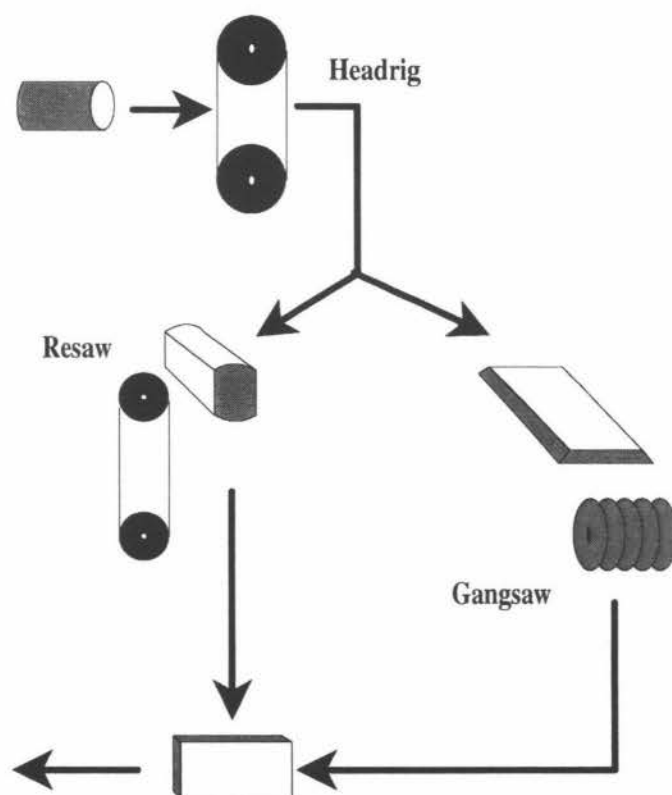

Figure 7-1: Layout of other machine centres

When instrumenting the band resaw the sensors chosen will likely be very similar to the headrig because it is almost identical except for size. The cants cut in this machine are small enough to be handled directly by the operator and fed using a side roller system. However, the gang saw is a completely different machine and therefore has different instrumenting requirements. The gang saw

is a bank of circular saws on the same arbor, and therefore has completely different mechanics involved. Some of the variables that may need to be monitored are individual blade movement, blade temperature, blade speed, and feed speed. Although the blade speed is supposed to be fixed it is more susceptible to degradation due to loading than bandsaws, and can have more serious repercussions.

While this expansion is happening, research will begin using the already working part of the system. Experiments that only need to use the headrig bandsaw such as testing new blade designs, quantifying log quality effects, and identifying other process quality variables are being planned. The design of these experiments will be similar to the wood density experiment performed as part of this project.

Index

Acquisition	31
Analysis & Display	32, 37, 38, 41, 42, 59, 60, 61, 62, 64, 66
Bandsaw	9, 14, 16, 18, 20, 22, 48, 68
Bandwheel	9, 16, 18, 20, 27, 52, 66
Client	31, 37, 38, 41, 49, 59, 60, 62, 63, 64, 66, 67
Client-server	30, 45
DAQ	31, 61
Data Flow	31
dBase	35
DDE	30, 31, 32, 40, 46, 66
Density	9, 48, 49, 51, 52, 53, 54, 55, 56, 57, 59, 60, 68
DOC	35
Event-based	29, 35
Forest Research	11, 14, 23, 25, 27, 38, 48, 60
Headrig	1, 10, 17, 19, 28, 40, 42, 47, 58, 65
Jaymor	20, 23, 27, 31, 36, 43, 60, 61
Link Manager	32, 34, 37, 38, 39, 40, 42, 46, 61, 62
Log-Based	54
LVDT	21, 22, 23, 25, 26, 52, 61, 63, 66
Monitor	32, 34, 35, 36, 37, 40, 42, 60, 61, 66
Object	39
PACKET	38
Pilodyn	49, 50, 54
PPC	40

Real-time	17, 43, 66
Sawchange	36, 61
Sawpattern	36
SCADA	15, 29
Server	34, 39, 59
Spiking	52
Tag-based	44
TCP/IP	30, 32, 37, 46, 62, 66
Triggering	23, 36
Waiariki	13

Glossary

Arbor	The central driving rod of a circular saw, similar to the axle of a car
Bias	The average lateral offset of a bandsaw during cutting from the lateral position when idling.
Cant	Central rectangular section of wood left after the outside slabs have been removed from the log
Carriage	A winch driven bed mounted on tracks used for moving the log past the saw
Curve Catcher	The common name for an inductive proximity sensor mounted on a saw to measure lateral deflection
Gang saw	A machine station consisting of a bank of circular saws on the same arbor, which cuts the slabs from the headrig into a set of boards in one pass
Green Timber	Timber that has been cut from a log but has not yet been dried in a kiln.
Gullet	The curved space between the teeth of a saw that is used to contain the sawdust during a cut
Jaymor Industries	Industrial partner in the project providing the log positioning equipment
Operating Envelope	An envelope of operation defined in terms of feed speed of the wood and the cut depth determined mainly by the calculated percentage of tooth gullet filled by the end of one pass through the wood.
Pilodyn	A device for measuring the outer-wood density of a log by measuring the penetration of a pin given a certain amount of force
TiTC	Timber Technology Centre. The place where the system was constructed as part of the Waiariki Institute of Technology, Rotorua

References

- ADELSBERGER, H.H., LAZANSKÝ, J., MARÍK, V. 1995. "Information management in computer integrated manufacturing: a comprehensive guide to state-of-the-art CIM solution", Springer-Verlag, Berlin, New York.
- BEAUREGARD, R. 1995. "Limits for saw performance", Systems for improving sawmill efficiencies pp1-15. Systems for improving sawmill efficiencies. Ministry of Forestry and New Zealand Forest Research Institute Ltd. Ministry of Forestry, Rotorua, New Zealand.
- CHABRIER, P., MARTIN, P. 1999. "An overview of methods for monitoring circular saw blade preparation", Holz als Roh-und-Werkstoff 57, pp157-163.
- CURRIE, W.L. 1994. "The strategic management of advanced manufacturing technology", Chartered Institute of Management Accountants, London.
- DOYLE, J. 1986. "Sawing variation in some New Zealand sawmills", FRI Bulletin (122). Forest Research Institute, Rotorua, New Zealand.
- EDLIN, B. 1994. "Forestry's rosy entrails", NZ Forest Industries Magazine 25(11)pp5. Profile Publishing, Auckland.
- GAUNT, D. 1998. "If you're not winning, change the rules", Wood Processing Newsletter (23), Sawmilling Section. Forest Research, Rotorua, New Zealand.
- HIGGS, J. 1989. "Economic benefits of improved sawmill technology", pp2.1-2.4. SawTech '89. Wood Machining Institute

- HOLØYEN, S. 1983. "Vibration patterns and natural frequencies of radially edge slotted circular saws", Report 67. Norsk Tretensik Institutt, Oslo, Norway.
- HOLØYEN, S., BIRKELAND, R. 1991. "Online productivity measurements of complex mutli-machinery sawmills", pp193-199. SawTech '91. Wood Machining Institute
- HUTTON, S.G. 1997. "Monitoring and diagnosis of bandsaw vibrations", pp75-84. SawTech '97. Wood Machining Institute
- LABEDA, A. 1993. "Practical implications of the log positioning error during primary breakdown", pp31-44. SawTech '93. Wood Machining Institute
- LUNSTRUM, S.J. 1985. "Balanced Saw Performance", Technical Report 12. Department of Agriculture, Forest Service, Forest Products Utilisation, Madison WI, USA.
- PRESSMAN, R.S. 1992. "Software engineering: A practioner's approach", International Edition, pp24. McGraw-Hill, Singapore.
- QUELCH, P.S. 1964. "Sawmill Feeds and Speeds", (Revised). Armstrong Manufacturing Company, Portland Oregon, USA.
- RHEMEV, J., CANO, T., TURNER, J., TRINCHERA, J. 1997. "A methodology to experimentally design low noise saws", pp265-273. 13th International Wood Machining Seminar. Forintek Canada Corp
- SCHAJER, G.S. 1986. "Why are guided saws more stable than unguided saws", Holz als Roh-und-Werkstoff (44), pp465-469.
- TAN, C.A., HUANG, D., FAN, Q. 1997. "Experimental active vibration control of moving bands", pp67-75. 13th International Wood Machining Seminar. Fointek Canada Corp
- TAYLOR, J., WHITE, J. 1997. "Development and mill trials of an active guide system", pp85-104. SawTech '97. Wood Machining Institute

- TAYLOR, J., WHITE, J. 1997. "Minimizing cutting bias in bandsaws", pp23-32. 13th International Wood Machining Seminar. Forintek Canada Corp
- TIAN, X., COWN, D. 1997. "Applications of machine vision in New Zealand wood processing", pp815-824. 13th International Wood Machining Seminar. Forintek Canada Corp
- TZAFESTAS, S.G. 1997. "Information technology enhances the competitive advantage", pp8-9. Advanced Manufacturing. Springer, Berlin, New York.
- WESTKAMPER, E., SCHADOFFSKY, O. 1995. "Evaluation of the surface on sawn wood", pp183-205. SawTech '95. Wood Machining Institute
- WIJESINGHE, R. 1998. "The Bandmill Book", pp85-88. Tech Pubs, Western Technigrafics Ltd, Vancouver.

Appendices

2.1 MICROVECTOR-i (MVi) SPECIFICATIONS

INPUT

Input supply voltage	380 to 440Vac
Input supply tolerance	-20% to +10%
Phase	3 phase
Input frequency range	48 to 62Hz
Power factor (fundamental)	.95
Input current	< output current
Power loss ride through	> 2 seconds
May also be operated from	450 to 700Vdc or 380 to 440Vac
single phase supply.	
Tacho pulse per revolution	500 to 4096

OUTPUT

Current overload capability	150% for 30 seconds
Frequency range	0 - ± 100Hz
Efficiency (full load, 50Hz)	>97%
Power on delay	<1 sec
Suit motor rated voltages	5 to 500 Vac
Suit motor rated frequencies	10 to 250Hz
Output voltage - cannot be greater than input voltage	
Control method	Flux vector control
Modulation method	Space vector modulation
Carrier frequency	4kHz/2kHz

ENVIRONMENTAL

Protection Standard:	
Cabinet	Dust and splashed water protected; Pollution degree 3
Operating temperature	0 to 50°C
Storage temperature	-40°C to +80°C
Relative humidity	<90%, noncondensing
Altitude	1000m
Altitude derating (>1000m)	-1% per 100m; 3000m max

MVI PROTECTION

Supply loss	Input phase loss
Output current limit	IGBT overload
Short circuited load	Ground fault
Low DC bus voltage	Regeneration limit
Excessive DC bus voltage	
MVi thermal model	Control PCB failure
Dynamic brake thermal model	Output phase loss

MOTOR PROTECTION

Stall avoidance	Motor overtemperature
PTC thermistor input	Torque limit
Shear pin mode	Overload alarm
Speed limit	Thermal model overtemp. trip

FREQUENCY CONTROL SOURCES

0 to 10Vdc, ±10Vdc, 4-20mA	Keyboard
Motorised potentiometer	Switch control - 7 preset
7 setting multi-reference	Resolution ±0.01Hz
Range ±100Hz	Accuracy 0.024%

TORQUE CONTROL SOURCES

0 to 10Vdc, ±10Vdc, 4-20mA	Keyboard
Motorised potentiometer	Switch control - 7 preset
7 setting multi-reference	Resolution ±2%
Range ±250% of full torque	Accuracy ±10%
Response <10ms 0-100% step	

CONFIGURABLE SWITCH CONTROLS

Stop	Start
Start/reset	Stop/reset
Inch 1,2,3	Direction invert
Alternative stop	Torque invert
Alternative acceleration	Inch invert
Alternative reference	Speed/torque mode selection
4 crane modes	Motorised potentiometer
Reset	Multi-reference

CONFIGURABLE RELAY OUTPUTS (23 selections)

3 relays; 230Vac/30Vdc/1A	1 x change over;
	2 x normally open

Output selection:

0	No Faults	12	Speed Reference Sign
1	Drive Fault	13	Speed Limit
2	Supply Fault	14	Torque Limit
3	O/L Fault	15	Voltage Limit
4	O/L Warning	16	Current Limit
5	Start	17	Crane Brake
6	Run	18	Comparator 1
7	Zero Speed	19	Comparator 2
8	At Set Speed	20	Window Comparator
9	Torque Sign	21	Always On
10	Speed Sign	22	Always Off
11	Torque Reference Sign		

CONFIGURABLE -10 TO +10v ANALOGUE OUTPUT (11 selections)

Output selection:

00	Null	06	Motor Torque
01	Output Current	07	Reference Speed
02	Output Voltage	08	Reference Torque
03	Bus Voltage	09	Motor Temperature
04	Motor Power	10	Inverter Temperature
05	Motor Speed		

MODEL	OUTPUT CURRENT Amps	OUTPUT kVA			OUTPUT POWER			DIMENSIONS			NETT WEIGHT kg
		380Vac kVA	415Vac kVA	440Vac kVA	380Vac kW	415Vac kW	440Vac kW	H mm	W mm	D mm	
MVi-90	90	59.2	64.7	68.6	45	51	55	1350	405	422	126
MVi-110	110	72.4	79.1	83.8	55	59	63	1350	405	422	126
MVi-140	140	92.1	101	107	75	80	80	1350	405	422	126
MVi-170	170	112	122	130	90	90	100	1350	545	422	160
MVi-205	205	135	147	156	110	110	110	1350	545	422	175
MVi-250	250	165	180	190	132	140	150	1350	545	422	175
MVi-300	300	197	216	239	160	160	185	1350	965	422	303
MVi-340	340	224	244	259	180	200	200	1350	965	422	303
MVi-480	480	316	345	366	257	280	300	1350	965	422	333
MVi-660	660	434	474	503	355	400	425	1350	1385	422	456
MVi-830P	830	547	598	634	445	485	520	Consists of two MVi-480			
MVi-1140P	1140	752	821	871	614	693	736	Consists of two MVi-660			

Linearly Variable Differential Transformers (LVDT)

Supplied to **RS** by Solartron Metrology Ltd.

Four ranges of LVDTs are available with a full range of associated instrumentation.

LVDTs are one of the most common forms of displacement transducer and consist of three coils, one for energisation, two for pick-up and a movable nickel iron core. The LVDT needs to be driven by a sine wave and the output amplitude and phase will be directly proportional to the position of the core with respect to the pick-up coils. A phase sensitive detector is required to demodulate this output signal.

DC LVDTs have all the associated electronics, (i.e. the oscillator and phase sensitive detector) built in to provide a simple measuring system. However because of the small size of the transducers and the necessarily compact electronics the performance of a.c. types (no electronics built-in) with separate electronic systems will be superior.

The main advantages of LVDTs are:

- Due to the lack of contact in the sensor, there is no wear problem as with potentiometers.
- Infinite resolution.
- High accuracy and linearity.
- No friction need be introduced into the system being measured as the LVDT is a non-contact sensor.
- Ranges from ± 1 mm to ± 50 mm available.

Miniature d.c. Energised LVDTs

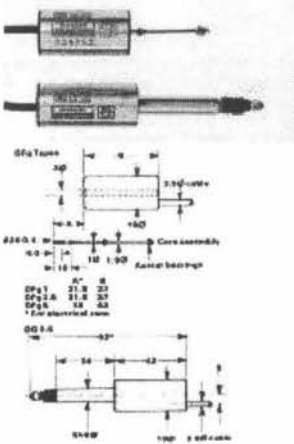

A range of four LVDTs with electronic oscillator and demodulator built in, giving a d.c. output proportional to core position.

The DFg series have separate coil/electronic assemblies with a free core fitted with a polyacetal homopolymer bearing which can be allowed to rub on the inside of the coil assembly thus easing the guiding requirements.

The DG 2.5 has a non-rotating spring-loaded armature running in precision linear ball bearings.

Technical Specification

Stroke DFg 1	±1 mm
DFg 2.5	±2.5 mm
DFg 5	±5.0 mm
DG 2.5	±2.5 mm
Sensitivity at 10 V energisation	780 mV/mm (typ.) 560 mV/mm (typ.) (DFg 5)
Current consumption at 10 V energisation	10-15 mA
Input voltage	10-24 V d.c.
Output ripple	<1% f.s.d.
Response time constant	1.5 ms
Frequency response	-3 dB at 100 Hz
Temperature range	-20°C to +80°C
Temperature coefficients	
DFg 1	<0.010%/°C
others	<0.005%/°C
Sensitivity	<0.01%/°C
Non-linearity	0.3%
Cable	3 m, 5-core P.V.C. screened
<i>Electrical connections</i>	
Red	+ve supply
Blue	0 V supply
White	+ve output
Green	0 V output
Yellow	N/C

All % are of total stroke

SSM = 1

type (unguided)	stroke	stock no.	price each	
			1-4	5-9
DFg 1	±1 mm	★646-454	\$456.73	\$435.71
DFg 2.5	±2.5 mm	★646-460	\$497.11	\$475.24
DFg 5	±5 mm	★646-476	\$513.34	\$491.22
(guided)				
DG 2.5	±2.5 mm	★646-482	\$751.49	\$713.86

Inductive Sensors

DC 3-Wire Analog Types M18, M30

Housing size	M18x1	M18x1	M30x1.5	M30x1.5
Mounting	flush	non-flush	flush	non-flush
Working range s_a	0.75...5 mm	1.25...8 mm	2...10 mm	3...15 mm
Linear range s_l	1.25...4 mm	1.75...5.75 mm	3...8 mm	4.5...12 mm

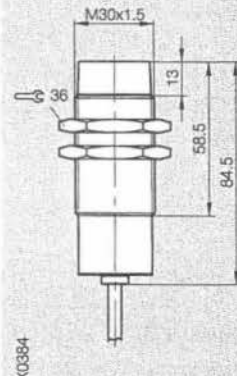
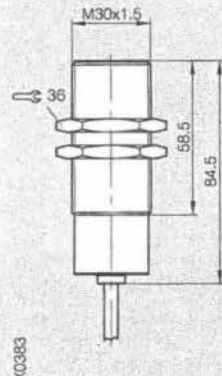
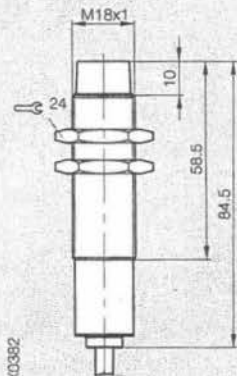
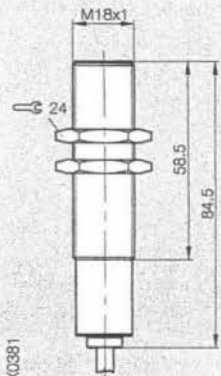

Ordering code	BAW 018-PB-1-K	BAW 018-PF-1-K	BAW 030-PB-1-K	BAW 030-PF-1-K
Repeat accuracy at constant temp.	≤ 0.02 mm	≤ 0.02 mm	≤ 0.02 mm	≤ 0.02 mm
Rated operational voltage U_B	24 V DC	24 V DC	24 V DC	24 V DC
Supply voltage U_B	10...30 V DC	10...30 V DC	10...30 V DC	10...30 V DC
Ripple	$\leq 10\%$	$\leq 10\%$	$\leq 10\%$	$\leq 10\%$
Rated insulation voltage U_i	75 V DC	75 V DC	75 V DC	75 V DC
Output current I_a	$s = 0$ mm: typ. 1.5 mA $s = \text{min.}$: 2.7 ± 0.3 mA $s = \text{max.}$: 8.6 ± 0.3 mA $s_a = \text{max.}$: typ. 10 mA	$s = 0$ mm: typ. 1.5 mA $s = \text{min.}$: 2.3 ± 0.3 mA $s = \text{max.}$: 8.5 ± 0.3 mA $s_a = \text{max.}$: typ. 10 mA	$s = 0$ mm: typ. 1.5 mA $s = \text{min.}$: 2.6 ± 0.3 mA $s = \text{max.}$: 8.6 ± 0.3 mA $s_a = \text{max.}$: typ. 10 mA	$s = 0$ mm: typ. 1.5 mA $s = \text{min.}$: 2.5 ± 0.3 mA $s = \text{max.}$: 8.7 ± 0.3 mA $s_a = \text{max.}$: typ. 10 mA
Min. load resistance R	0 Ω	0 Ω	0 Ω	0 Ω
Max. load resistance R	$(U_B - 6) \times 100$ [Ω]	$(U_B - 6) \times 100$ [Ω]	$(U_B - 6) \times 100$ [Ω]	$(U_B - 6) \times 100$ [Ω]
No-load supply current I_0 damped/und.	≤ 12 mA / ≤ 12 mA	≤ 12 mA / ≤ 12 mA	≤ 12 mA / ≤ 12 mA	≤ 12 mA / ≤ 12 mA
Voltage rise	≥ 5 mA/ms	≥ 5 mA/ms	≥ 5 mA/ms	≥ 5 mA/ms
Short circuit/overload protected	yes	yes	yes	yes
Ambient temperature range T_a	-10...+60 °C	-10...+60 °C	-10...+60 °C	-10...+60 °C
Temperature drift at s_a max.	$\pm 5\%$ of s_a	$\pm 5\%$ of s_a	$\pm 5\%$ of s_a	$\pm 5\%$ of s_a
Time delay before availability t_d	≤ 40 ms	≤ 40 ms	≤ 40 ms	≤ 40 ms
Utilization categories	DC 12	DC 12	DC 12	DC 12
Function indication	yes	yes	yes	yes
Degree of protection per IEC 529	IP 67	IP 67	IP 67	IP 67
Housing material	nickel plated brass	nickel plated brass	nickel plated brass	nickel plated brass
Material of sensing face	PBTP	PBTP	PBTP	PBTP
Connection	cable LiYY-0	cable LiYY-0	cable LiYY-0	cable LiYY-0
No. of wires \times conductor cross section	3 \times 0.34 mm ²	3 \times 0.34 mm ²	3 \times 0.34 mm ²	3 \times 0.34 mm ²

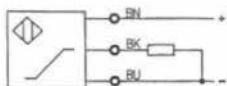

connection diagram

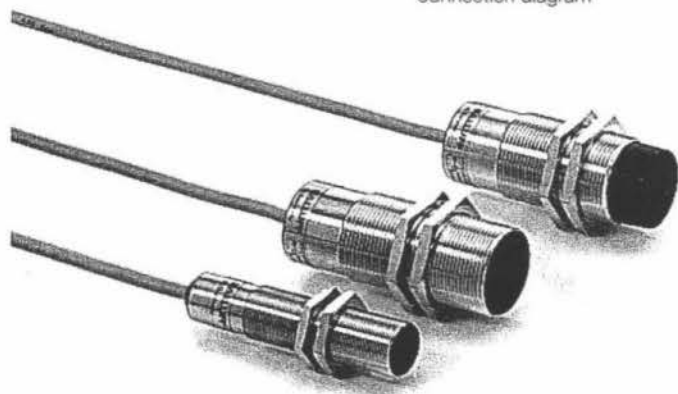

Approach characteristic curves BAW 018 P... and BAW 030 P ...

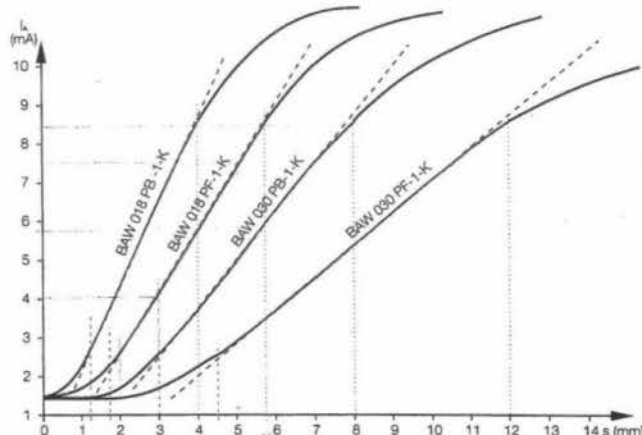

Low-Cost Multifunction I/O Board for PCI

PCI-1200

Features

Analog input

- 8 single-ended, 4 differential channels
- 12-bit resolution
- 100 kS/s sampling rate
- Gains of 1, 2, 5, 10, 20, 50, and 100
- Range of 0-10 V, ± 5 V
- Software calibration

Analog output

- 2 channels, 12-bit resolution
- Range of 0-10 V, ± 5 V
- Software calibration

Digital I/O

- 24 TTL lines in 8-bit ports
- Unidirectional and bidirectional
- 2-wire handshake capability

Counter/Timers

- Three 16-bit resolution
- 8 MHz maximum source frequency

Triggering

- Digital

Hardware architecture

- MITE™ PCI bus-master interface

NI-DAQ® Software

- | | |
|-------------|------------|
| Windows NT | Windows 95 |
| Windows 3.1 | Mac OS |

Application Software

- | | |
|-----------------|-----------------|
| LabVIEW® | BridgeVIEW™ |
| LabWindows®/CVI | ComponentWorks™ |
| VirtualBench™ | Measure® |

Solutions

- Signal analysis
- Data logging
- Temperature measurements
- DC voltage measurements
- Programmable voltage source
- Generate experimental stimuli
- Monitoring and control of motors, fans, lights, ...
- Pulse generation
- Frequency measurement
- General timing

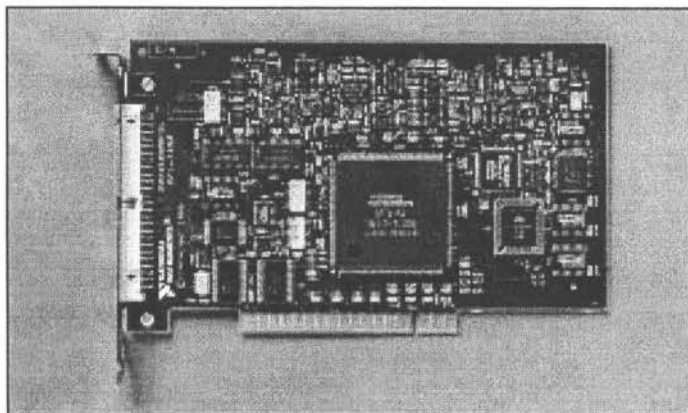

PCI-1200

Overview

The PCI-1200 is a low-cost, multifunction analog, digital, and timing I/O board for computers with PCI slots. It is packaged with either NI-DAQ driver software for Mac OS or Windows NT/95/3.1.

For additional analog inputs and signal conditioning, you can use the SCXI™ signal conditioning system to multiplex, isolate, and amplify up to 384 low-level signals into a single board.

Hardware

Analog Input – The PCI-1200 has two CMOS analog input multiplexers connected to eight analog input channels. The input circuitry gives input overvoltage protection of ± 35 V powered on or ± 25 V powered off. You can use the analog input channels as eight single-ended inputs, eight non-referenced single-ended inputs with a shared common, or four fully differential inputs.

Voltage input range is software programmable for 0-10 V (unipolar) or ± 5 V (bipolar). A software-programmable gain amplifier has gain selections of 1, 2, 5, 10, 20, 50, or 100.

The PCI-1200 has a 12-bit ADC with analog signal resolution of 2.44 mV at a gain of 1. You can achieve finer resolutions down to 24.4 μ V by using a higher gain. The 12-bit output of the ADC is automatically sign-extended to 16 bits.

The PCI-1200 performs both single A/D

conversions and multiple A/D conversions of a set number of samples. A 4,096 word-deep first-in-first-out (FIFO) memory buffers the data during multiple A/D conversions. Multiple A/D conversions can be handled by DMA, programmed I/O, or interrupts.

An onboard counter/timer controls the timing of multiple A/D conversions. The counter/timer generates the sample interval clock with a resolution of 1 μ s. As an alternative, an external signal can generate the timing for the sample interval. Data acquisition with the PCI-1200 is available in three modes: 1) continuous acquisition of a single channel, 2) multichannel acquisition with continuous scanning, or 3) multichannel acquisition with interval scanning. In the third mode, all channels are scanned at one sample interval, with a second interval determining the time before repeating the scan. Both single A/D conversions and multiple A/D conversion sample sequences are initiated from either software or external timing control signals.

There are two hardware triggering modes – pretrigger mode and posttrigger mode. In pretrigger mode, the board collects samples until a trigger is received at the external trigger input, and then continues to collect a specified number of samples. In posttrigger mode, the board collects a specified number of samples after the board receives a trigger.

You can scan any number of channels between 2 and 8 in single-ended or between 1 and 4

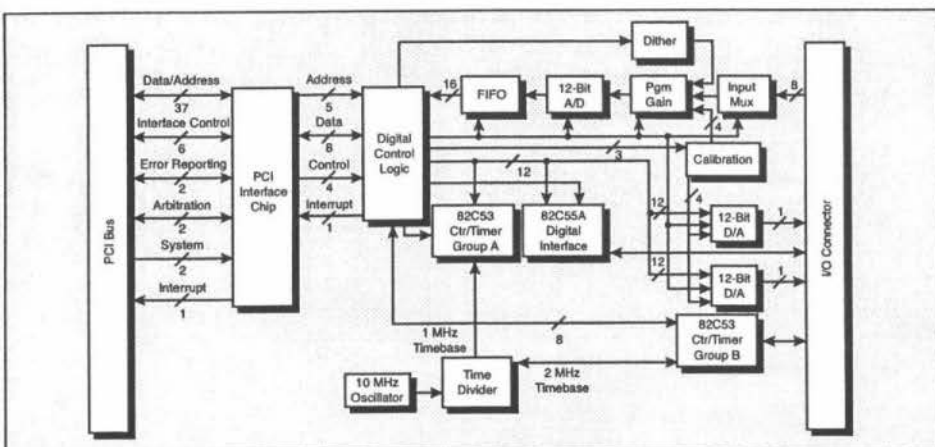

Figure 1. PCI-1200 Block Diagram

in differential mode in the multichannel acquisition mode. These channels are scanned in a round-robin sequence, taking one reading per interval with scanning always occurring in the same order – beginning with the last channel through 0.

Analog Output – The PCI-1200 has two double-buffered 12-bit DACs that are connected to two analog output channels. You can independently configure each channel through software for unipolar (0-10 V) or bipolar (± 5 V) operation. The resolution of the 12-bit DAC is 2.44 mV in both polarities.

You can handle waveform generation by programmed I/O or interrupts. One of the 82C53 counter/timers is used with the DACs for waveform generation. The counter/timer generates periodic interrupts and updates signals for the double-buffered DACs.

Digital I/O – The PCI-1200 has 24 digital I/O lines that are configurable as three 8-bit ports for input, output, bidirectional, or handshaking modes. Two of the ports can drive Darlington transistors directly for higher current applications. The digital I/O lines are TTL compatible. The digital output ports can sink 2.5 mA on each line.

PCI Interface Circuitry – The PCI-1200 uses the MITE ASIC to interface the board to the PCI bus and to provide bus master capability. All bus-related configuration, such as base memory address and interrupt assign-

ments, are automatically configured through software.

Counter/Timer – The PCI-1200 uses two 82C53 system timing controllers (STCs) for counting and timing. Each STC contains three independent, 16-bit counter/timers. One of the STCs, counter A, is dedicated for A/D and D/A timing. The three counters on the other STC, counter B, are available to you for general time-related functions, such as clock output, pulse output, and event and frequency measurement. Counter 1 can be used to obtain the scan interval in the interval scanning mode.

I/O Connector – The I/O connector is a 50-pin male ribbon cable connector diagrammed in Figure 2. ACH<0..7> are eight analog input channels. DAC0OUT and DAC1OUT are the two analog output channels. A TTL low-level signal on the EXTUPDATE* pin updates the analog output channels. A rising edge on EXTUPDATE* generates an interrupt on the PCI I/O channel, making externally controlled voltage output possible. EXTCONV* can control individual A/D conversions externally. You can use EXTTRIG, the external trigger input for pretrigger or posttrigger applications. CLKB<1..2>, GATB<0..2>, and OUTB<0..2> are the clock, gate, and output of the user-available counter. PA<0..7>, PB<0..7>, and PC<0..7> are the three 8-bit digital I/O ports.

ACH0	1	2	ACH1
ACH2	3	4	ACH3
ACH4	5	6	ACH5
ACH6	7	8	ACH7
AISENSE/AIGND	9	10	DAC0OUT
AGND	11	12	DAC1OUT
DGND	13	14	PA0
PA1	15	16	PA2
PA3	17	18	PA4
PA5	19	20	PA6
PA7	21	22	PB0
PB1	23	24	PB2
PB3	25	26	PB4
PB5	27	28	PB6
PB7	29	30	PC0
PC1	31	32	PC2
PC3	33	34	PC4
PC5	35	36	PC6
PC7	37	38	EXTTRIG
EXTUPDATE*	39	40	EXTCONV*
OUTB0	41	42	GATB0
OUTB1	43	44	GATB1
CLKB1	45	46	OUTB2
GATB2	47	48	CLKB2
+5V	49	50	DGND

Figure 2. PCI-1200 I/O Connector Pin Assignments

Part Numbers

PCI-1200 and NI-DAQ for
Windows NT/95/3.1777386-01*
Mac OS777097-01

50-pin Connector Blocks and Cables

CB-50LP low-cost
connector block.....777101-01
Type NB1 50-pin female to 50-pin
female ribbon cable
0.5 m180524-05
1.0 m180524-10
2.0 m180524-20

* Includes NI-DAQ on CD. For 1.44 MB
3.5 in. disks, order 777389-01.

Other accessories include:

SCXI Signal conditioning system
SC-2042-RTD RTD conditioning accessory
and general terminal block
SC-2043-SG Strain gage conditioning
accessory and general terminal block
5B Series Analog conditioning modules
ER-8/16 Electromechanical relays
SC-206X Digital conditioning boards
SSR Series Digital conditioning modules
SC-2053 Cable adapters for signal
conditioning
SC-2071 Termination bread board
BNC-2081 BNC accessory
CB-50 DIN rail mountable connector block

Specifications

These specifications are typical at 25 °C unless otherwise stated.

Analog Input

Number of channels	8 single-ended, 8 non-referenced single-ended, or 4 differential, software selectable
Type of ADC	Successive approximation
Resolution	12 bits, 1 in 4,096
Maximum sampling rate	100 kS/s
Input signal ranges	

Channel Gain (Software Selectable)	Input Range (Software Selectable)	
	unipolar	bipolar
1	0 to 10 V	±5 V
2	0 to 5 V	±2.5 V
5	0 to 2 V	±1 V
10	0 to 1 V	±500 mV
20	0 to 500 mV	±250 mV
50	0 to 200 mV	±100 mV
100	0 to 100 mV	±50 mV

Input coupling	DC
Maximum working voltage (signal + common mode)	IN DI or NRSE mode, the negative input/AISENSE should remain within ±5 V (bipolar) or -5 to 2 V (unipolar) of AGND. The positive input should remain within -5 V to +10 V of AGND.
Overvoltage protection	±35 V powered on, ±25 V powered off
Inputs protected	ACH-d.7>
FIFO buffer size	4,096 samples
Data transfers	DMA Interrupts, programmed I/O
DMA modes	Scatter-gather
Dither	Available
Transfer Characteristics	
Relative accuracy	±0.5 LSB typical dithered, ±1.5 LSB maximum undithered
DNL	±1 LSB maximum
No missing codes	12 bits, guaranteed
Offset error	
Pregain error after calibration	10 µV maximum
Pregain error before calibration	±20 mV maximum
Postgain error after calibration	1 mV maximum
Postgain error before calibration	±200 mV maximum
Gain error (relative to calibration reference)	
After calibration	0.02% of reading maximum
Before calibration	±2% of reading maximum
Gain ≠ 1 with gain error adjusted to 0 at gain = 1	±0.8% of reading maximum
Amplifier Characteristics	
Input bias current	±100 pA
Input offset current	±100 pA
Input impedance	
Normal powered on	100 GΩ in parallel with 50 pF
Powered off	4.7 kΩ minimum
Overload	4.7 kΩ minimum
CMRR	70 dB, DC to 60 Hz
Dynamic Characteristics	
Small signal (-3 dB)	

Gain	Bandwidth
1 to 10	250 kHz
20	150 kHz
50	60 kHz
100	30 kHz

Settling time for full-scale step

Gain	Accuracy ±0.024% (±1 LSB)	
	typical	maximum
1	10 µs	14 µs
2 to 10	13 µs	16 µs
20	15 µs	19 µs
50	27 µs	34 µs
100	60 µs	80 µs

System noise (including quantization error)

Gain	Dither Off	Dither On
1 to 50	0.3 LSB rms	0.5 LSB rms
100	0.5 LSB rms	0.7 LSB rms

Stability	
Recommended warm-up time	15 minutes
Offset temperature coefficient	
Pregain	±15 µV/°C
Postgain	±100 µV/°C
Gain temperature coefficient	±40 ppm/°C

Analog Output

Output Characteristics	
Number of channels	Two voltage
Resolution	12 bits, 1 in 4,096
Typical update rate	20 S/s to 1 kS/s (system dependent)
Type of DAC	Double buffered
Data transfers	Interrupts, programmed I/O
Transfer Characteristics	
Relative accuracy (INL)	±0.25 LSB typical, ±0.50 LSB maximum
DNL	±0.25 LSB typical, ±0.75 LSB maximum
Monotonicity	12 bits, guaranteed
Offset error	
After calibration	±0.2 mV maximum
Before calibration	±50 mV maximum
Gain error (relative to internal reference)	
After calibration	0.004% of reading maximum
Before calibration	±1% of reading maximum

Voltage Output

Ranges	0 to 10 V, ±5 V, software selectable
Output coupling	DC
Output impedance	0.2 Ω typical
Current drive	±2 mA
Protection	Short circuit to ground
Power-on state	0 V
Dynamic Characteristics	
Settling time to full-scale range (FSR)	5 µs
Stability	
Offset temperature coefficient	±50 µV/°C
Gain temperature coefficient	±30 ppm/°C

Digital I/O

Number of channels	24 I/O (three 8-bit ports; uses the 82C55A PPI)
Compatibility	TTL
Digital logic levels	

Level	Minimum	Maximum
Input low voltage	-0.3 V	0.8 V
Input high voltage	2.2 V	5.3 V
Output low voltage (<i>I</i> _{out} = 2.5 mA)	-	0.4 V
Output high voltage (<i>I</i> _{out} = -2.5 mA)	3.7 V	-
(<i>I</i> _{out} = -40 µA)	4.2 V	-

Power-on state	All ports mode 0 Input
Protection	-0.5 V to 5.5 V powered on, ±0.5 V powered off
Data transfers	Interrupts, programmed I/O

Timing I/O

Number of channels	3 counter/timers
Protection	-0.5 V to 5.5 V powered on, ±0.5 V powered off
Resolution	16 bits
Compatibility	TTL
Base clock available	2 MHz
Base clock accuracy	±50 ppm maximum
Maximum source frequency	8 MHz
Minimum source pulse duration	125 ns
Minimum gate pulse duration	100 µs
Digital logic levels	

Level	Minimum	Maximum
Input low voltage	-0.3 V	0.8 V
Input high voltage	2.2 V	5.3 V
Output low voltage (<i>I</i> _{out} = 2.1 mA)	-	0.45 V
Output high voltage (<i>I</i> _{out} = 0.92 mA)	3.7 V	-

Protection	-0.5 to 5.5 V powered on, ±0.5 V powered off
Data transfer	Interrupts, programmed I/O

Digital Trigger

Compatibility	TTL
Response	Rising edge
Pulse width	50 ns minimum

Power Requirements

Power consumption	400 mA at +5 VDC (±5%)
Power available at I/O connector	+4.65 to +5.25 V fused at 1A

Bus Interface

Master, slave

Physical

Dimensions	17.5 x 10.6 cm (6.9 by 4.2 in.)
I/O connectors	50-pin male

Environment

Operating temperature	0 ° to 50 °C
Storage temperature	-55 ° to 150 °C
Relative humidity	5% to 90% noncondensing

Seminars/Training

Free and fee-paid seminars are presented several times a year in cities around the world. Comprehensive, fee-paid training courses are available at National Instruments offices, or at customer sites. Call for training schedules.

Support

National Instruments provides comprehensive technical assistance around the world. In the U.S. and Canada, applications engineers are available Monday through Friday from 8:00 a.m. to 6:00 p.m. (central time), at (512) 794-0100. In other countries, contact the nearest branch office. You can fax questions to corporate headquarters any time at (512) 794-5678.

National Instruments sponsors a wide variety of user group activities, such as user group meetings at trade shows and at large industrial sites. Our users also receive our quarterly *Instrumentation Newsletter*™ with the latest information on new products, product updates, application tips, and current events.

Warranty

All National Instruments GPIB hardware products are covered by a two-year warranty from the date of shipment. Data acquisition boards and VXIbus and MXIbus products are covered by a one-year warranty. The warranty covers board failures, components, cables, connectors, and switches, but does not cover faults caused by misuse. The owner may return a failed assembly to National Instruments for repair during the warranty period. Extended warranties are available at an additional charge.

Information furnished by National Instruments is believed to be accurate and reliable. National Instruments reserves the right to change product specifications without notice.



U.S. Corporate Headquarters: Tel: (512) 794-0100 • Fax: (512) 794-8411 • info@natinst.com • www.natinst.com

Branch Offices: Australia 03 9879 5166 • Austria 0662 45 79 90 0 • Belgium 02 757 00 20 • Canada 905 785 0085 • Denmark 45 76 26 00
Finland 09 527 2321 • France 01 48 14 24 24 • Germany 089 741 31 30 • Hong Kong 2645 3186 • Israel 03 5734815 • Italy 02 413091 • Japan 03 5472 2970
Korea 02 596 7456 • Mexico 95 800 010 0793 • Netherlands 0348 433466 • Norway 32 84 84 00 • Singapore 2265886 • Spain 91 640 0085
Sweden 08 730 49 70 • Switzerland 056 200 51 51 • Taiwan 02 377 1200 • U.K. 01635 523545

© Copyright 1997 National Instruments Corporation. All rights reserved. Product and company names listed are trademarks or trade names of their respective companies.