

Copyright is owned by the Author of the thesis. Permission is given for a copy to be downloaded by an individual for the purpose of research and private study only. The thesis may not be reproduced elsewhere without the permission of the Author.

PREDICTION AND QUANTIFICATION OF APPLE BRUISING

A thesis

submitted in partial fulfilment
of the requirements for the degree
of

Doctor of Philosophy

in
Agricultural Engineering

at
Massey University
Palmerston North
New Zealand

David Weilong Pang
1993

ACKNOWLEDGEMENT

I would like to thank Dr. Cliff J. Studman, chief supervisor (Department of Agricultural Engineering), for his generous advice, thoughtful guidance, and encouragement throughout this study, Dr. Nigel H. Banks, associate supervisor (Department of Plant Science), for his valuable suggestions, helpful discussions, and encouragement, and Professor G. T. Ward, associate supervisor (Lincoln University) for his support of this project.

I wish to express my appreciation to Dr. Gavin L. Wall, head of the Department, for his understanding and support of this project, Ian A. Painter and R. L. Bolter for their assistance with laboratory experiments and construction of apparatus, and other members and postgraduates of the Department of Agricultural Engineering for their friendship and cares.

In particular, I wish to express my appreciation to the New Zealand Apple and Pear Marketing Board for the financial support, and to Mrs. Stella McLeod for her helpful suggestions and continued interest in this project.

The fruit growers and packers in Hastings are also thanked for their co-operation during the Instrumented Sphere tests, and for the help in selection of fruit samples.

Finally, I wish to thank my wife Xiao-Min for her assistance with some of the experimental work, and for her understanding and moral support, without which this study would have been impossible.

TABLE OF CONTENTS

| | |
|---|-----|
| ACKNOWLEDGMENTS | i |
| TABLE OF CONTENTS | ii |
| LIST OF SYMBOLS | vii |
| LIST OF FIGURES | ix |
| LIST OF TABLES | xiv |
| ABSTRACT | xv |
| | |
| 1. GENERAL INTRODUCTION | 1 |
| | |
| 2. REVIEW OF LITERATURE | 8 |
| 2.1 Introduction | 8 |
| 2.2 Method of determining apple bruising | 8 |
| 2.3 Bruise susceptibility | 12 |
| 2.3.1 Methods of determining bruisability | 12 |
| 2.3.2 Application of bruise susceptibility | 15 |
| 2.4 Theoretical analysis of fruit impact | 18 |
| 2.4.1 Hertz contact theory for fruit impact | 18 |
| 2.4.2 Bruise prediction models | 21 |
| 2.5 Impact detection devices and their implications | 23 |
| 2.5.1 Bruise prediction using an Instrumented Sphere | 25 |
| 2.6 Bruise boundary in packaging theory | 25 |
| 2.7 Practical studies of apple packing lines | 26 |
| 2.7.1 Apple damage assessment on American packing lines | 27 |
| 2.7.2 Bruise damage in New Zealand apples | 29 |
| 2.7.3 Discussion | 31 |

| | | |
|-------|--|----|
| 3 | INVESTIGATION OF BRUISING PHENOMENA | 33 |
| 3.1 | Introduction | 33 |
| 3.2 | Materials and methods | 34 |
| 3.2.1 | Temperature effects on bruising of Gala | 37 |
| 3.2.2 | Cultivar differences in bruising | 37 |
| 3.2.3 | Assessor effects | 38 |
| 3.3 | Results | 38 |
| 3.3.1 | Type of bruises | 38 |
| 3.3.2 | Bruise distribution on apple | 39 |
| 3.3.3 | Frequency distribution of bruise sizes | 42 |
| 3.3.4 | Discussion | 45 |
| 3.3.5 | Human effects on assessment of bruising | 46 |
| 3.4 | Conclusions | 52 |
| 4 | USE OF AN INSTRUMENTED SPHERE | 53 |
| 4.1 | Introduction | 53 |
| 4.2 | Description of Instrumented Sphere | 53 |
| 4.3 | Determination of bruise threshold | 58 |
| 4.4 | Adjustment of IS calibration parameters | 58 |
| 4.5 | Calibration of Instrumented sphere | 63 |
| 4.6 | Commercial packing line tests with Instrumented Sphere | 67 |
| 4.7 | Discussion | 69 |
| 4.8 | Conclusions | 71 |
| 5. | BRUISING DAMAGE IN APPLE-TO-APPLE IMPACT | 72 |
| 5.1. | Introduction | 72 |
| 5.2. | Materials and Methods | 73 |
| 5.2.1 | Experimental details | 73 |

| | | |
|-------|---|-----------|
| 5.3.2 | Test procedure | 73 |
| 5.2.3 | Bruise evaluation | 74 |
| 5.3. | Experimental results | 75 |
| 5.3.1 | Bruise volume | 75 |
| 5.3.2 | Contact area | 77 |
| 5.3.3 | Coefficient of restitution | 80 |
| 5.4. | Discussion | 82 |
| 5.4.1 | Total bruise volume and distribution between apples | 82 |
| 5.4.2 | Contact area | 84 |
| 5.4.3 | Bruise surface area | 85 |
| 5.4.4 | Coefficient of restitution | 85 |
| 5.4.5 | Use of elasticity theory to predict apple-to-apple bruising .. | 86 |
| 5.5. | Conclusions | 88 |
| 6. | ANALYSIS OF DAMAGE THRESHOLDS IN APPLE-TO-APPLE IMPACTS USING AN INSTRUMENTED SPHERE | 89 |
| 6.1 | Introduction | 89 |
| 6.2 | Materials and methods | 90 |
| 6.2.1 | Fruit preparation | 90 |
| 6.2.2 | Experimental details | 90 |
| 6.3 | Results | 91 |
| 6.3.1 | Bruise visibility | 91 |
| 6.3.2 | Relationship between bruising area, contact area, and impact energy | 92 |
| 6.3.3 | Instrumented Sphere output | 96 |
| 6.3.4 | Determination of bruise thresholds | 97 |
| 6.3.5 | Interpretation of Instrumented Sphere output | 100 |
| 6.4 | Discussion | 100 |

| | | |
|-----|--|-----|
| 6.5 | Conclusions | 103 |
| 7. | USE OF AN INSTRUMENTED SPHERE FOR ASSESSING APPLE BRUISING THRESHOLDS | 104 |
| 7.1 | Introduction | 104 |
| 7.2 | Materials and Methods | 104 |
| | 7.2.1 Experimental details | 104 |
| | 7.2.2 Bruise analysis and determination of bruise thresholds | 110 |
| 7.3 | Results | 111 |
| | 7.3.1 Fruit Tests | 111 |
| | 7.3.2 Relationship between bruise area and peak acceleration ... | 113 |
| | 7.3.3 Determination of surface response lines | 116 |
| | 7.3.4 Potential bruise boundary | 117 |
| 7.4 | Discussion | 120 |
| 7.5 | Conclusions | 124 |
| 8. | CHANGES IN APPLE BRUISE SUSCEPTIBILITY WITH IMPACT CONDITIONS AND STORAGE | 125 |
| 8.1 | Introduction | 125 |
| 8.2 | Materials and methods | 126 |
| 8.3 | Results | 127 |
| 8.4 | Discussion | 137 |
| 8.5 | Conclusions | 138 |
| 9. | A NEW APPROACH TO ASSESS APPLE BRUISING | 139 |
| 9.1 | Introduction | 139 |
| 9.2 | Methods of determining fruit firmness and maturity | 139 |
| 9.3 | Materials and methods | 142 |

| | | |
|-------|---|-----|
| 9.3.1 | Experimental apparatus | 142 |
| 9.3.2 | Fruit preparation and Bruise Factor test | 147 |
| 9.4 | Experimental results | 151 |
| 9.4.1 | Temperature effects on fruit properties | 151 |
| 9.4.2 | The differences of Bruise Factors on different varieties of apples | 155 |
| 9.4.3 | Granny Smith apples at different harvest times | 156 |
| 9.5 | Discussion | 157 |
| 9.6 | Conclusions | 160 |
| 10. | General Discussion | 161 |
| 10.1 | Apple bruising on commercial packing lines | 161 |
| 10.2 | Quantification of apple bruising | 163 |
| 10.3 | Prediction of bruising by using an Instrumented Sphere | 164 |
| 10.4 | Suggestions for future work | 166 |
| 11. | Summary and conclusions | 167 |
| 12. | References | 170 |
| | Appendix A | 177 |
| | Appendix B | 178 |
| | Appendix C | 181 |
| | Appendix D | 183 |
| | Appendix E | 184 |
| | Appendix F | 191 |

LIST OF SYMBOLS

| | | |
|------------------------------|-------|--|
| A | | Contact area (cm ²) |
| A_{ais} | | Peak acceleration by adjusted calibration file (g) |
| $A_{\text{b}}(A_{\text{b}})$ | | Bruise area (cm ²) |
| A_{cb} | | Contact area or bruise area (cm ²) |
| A_{r} | | Acceleration recorded by the accelerometer (g) |
| A_{ois} | | Peak acceleration by original calibration file (g) |
| a | | Radius of contact surface (m) |
| a_{n} | | Normal component of the acceleration of mass centre |
| a_{t} | | Tangential component of the acceleration of mass centre |
| BD | | Bruise diameter (mm) |
| $BDAH$ | | Adjusted Hertz bruise diameter (mm) |
| D | | The surface diameter of bruise (mm) |
| D_{a} | | Apple diameter (mm) |
| d | | Depth of bruise at the centre of bruise region (mm) |
| d_1 | | Major diameter of bruise area or contact area (mm) |
| d_2 | | Minor diameter of bruise area or contact area (mm) |
| E_{a} | | Energy absorbed (J) |
| E_{i} | | Impact energy (J) |
| E_1 | | Elasticity modulus of the first sphere (kg/m ²) |
| E_2 | | Elasticity modulus of the second sphere (kg/m ²) |
| e | | Coefficient of restitution |
| F | | Magness-Taylor force (kg) |
| g | | Acceleration due to gravity (9.81m/s ²) |
| H (h) | | Drop height (m) |
| H_1 | | Rebound height (mm) |
| h_{b} | | Depth of bruising below the contact plane (mm) |
| h_1 | | Depth of bruise (mm) |

| | | |
|------------|-------|--|
| h_2 | | Depth of bruise region (mm) |
| I | | Moment of inertia (kg m ²) |
| K | | Two-fifths power of impact energy (J ^{2/5}) |
| k_p | | Initial drop height (mm) |
| k_1 | | Bruise susceptibility (cm ³ /J) |
| k_2 | | Constant |
| l | | Length of the arm (m) |
| m | | Mass of apple (kg) |
| m_i | | Mass of a particle (kg) |
| m_p | | Mass of aluminium arm (kg) |
| m_1 | | Mass of first sphere (kg) |
| m_2 | | Mass of second sphere (kg) |
| PA | | Peak acceleration (g) |
| q_p | | Geometrical progression factor |
| R | | Radius of apple (mm) |
| R_1 | | Radius of first sphere (m) |
| R_2 | | Radius of second sphere (m) |
| r_i | | Distance from the particle to rotating point O (m) |
| V | | Velocity of approach (m/s) |
| V_{a1} | | Total volume (cm ³) |
| V_{a2} | | Bruise volume above the contact plane (cm ³) |
| V_b | | Bruise volume (cm ³) |
| VC | | Velocity change (m/s) |
| W | | Apple weight (kg) |
| X | | Height of bruise above contact plane (mm) |
| α | | Approach of two impacting objects (m) |
| α_a | | Angular acceleration |
| λ | | Regressed ration |
| ν_1 | | Poisson's ratio of the first sphere |

| | |
|----------------|--|
| ν_2 | Poisson's ratio of the second sphere |
| ψ | Ratio of total velocity change to the maximum acceleration |
| ω | Angular velocity |

LIST OF FIGURES

| | | |
|-------------|---|----|
| Figure 1.1 | A typical New Zealand fruit handling chain | 3 |
| Figure 2.1 | Cross-section of idealized bruise showing symbols used by Holt and Schoorl (1977) | 10 |
| Figure 2.2 | Sampling sites along packing line | 28 |
| Figure 2.3 | Problem points on New Zealand packing lines | 30 |
| Figure 3.1 | Treeways two-lane mechanical grading machine used for studying the bruise damage | 34 |
| Figure 3.2 | Fruit were placed onto sorting table of the grader | 36 |
| Figure 3.3 | Percentage of bruises observed from different parts of fresh fruit | 40 |
| Figure 3.4 | Percentage of bruises observed from different parts of cooled fruit | 41 |
| Figure 3.5 | Percentage of bruises observed from different parts of warmed Gala apples | 42 |
| Figure 3.6 | Frequency distribution of bruise areas (cm ²) produced by Treeways fruit grader | 43 |
| Figure 3.7 | Total number of visible bruises without skin removal on fresh, cooled, and warmed Gala picked commercially based on background colour | 44 |
| Figure 3.8 | Number of bruises on every five Granny Smith apples observed by assessor 1 on time sequence | 48 |
| Figure 3.9 | Number of bruises on every five Granny Smith apples observed by assessor 2 on time sequence | 49 |
| Figure 3.10 | Number of bruises on every five Granny Smith apples observed by assessor 3 on time sequence from morning to afternoon | 50 |
| Figure 3.11 | Number of bruises on every five fruit observed | |

| | | |
|-------------|--|----|
| | by assessor 1 in two days on one hundred Granny Smith apples under the same impact conditions | 51 |
| Figure 4.1 | Instrumented Sphere used in this study | 55 |
| Figure 4.2 | A typical output of the Instrumented Sphere | 56 |
| Figure 4.3 | A typical un-calibrated pulse (integer format) recorded by the Instrumented Sphere during an impact against flat steel surface in direction of Z axis | 57 |
| Figure 4.4 | Apple bruising initiation threshold lines (0-10, 50, and 100% bruising) for velocity change versus peak acceleration compared to impact surface response lines created using a 89 mm diameter IS | 59 |
| Figure 4.5 | Peak acceleration (g) recorded at three different directions of Instrumented Sphere | 60 |
| Figure 4.6 | Peak accelerations produced by the Instrumented Sphere with new calibration file | 62 |
| Figure 4.7 | Experimental device to calibrate Instrumented Sphere | 64 |
| Figure 4.8 | Impact pulse obtained by the Accelerometer and Oscilloscope | 65 |
| Figure 4.9 | Impact pulse obtained by Instrumented Sphere | 66 |
| Figure 4.10 | Relationship between the peak acceleration recorded by IS both with adjusted and original calibration files and the acceleration measured by using an accelerometer | 67 |
| Figure 4.11 | Impacts recorded by IS from a New Zealand typical fruit packing line | 68 |
| Figure 4.12 | Instrumented Sphere data resulting from the impacts produced as the sphere fell into a final size packing bin, during commercial grading operations on Gala apples | 69 |
| Figure 5.1 | Cross-section of idealized bruise showing symbols | |

| | | |
|------------|--|-----|
| | used in bruise volume calculations. The shaded area represents the bruised region. | 76 |
| Figure 5.2 | Total bruise volume versus $5/2$ power of contact area for the values of contact area $> 1.46 \text{ cm}^2$ | 77 |
| Figure 5.3 | Contact area versus impact energy for Granny Smith apples | 78 |
| Figure 5.4 | Total bruise volume versus energy absorbed for Granny Smith apples | 79 |
| Figure 5.5 | Total bruise volume versus contact area for the values of contact area $\leq 1.46 \text{ cm}^2$ | 80 |
| Figure 5.6 | Coefficient of restitution versus impact energy for free impact of apple-to-apple | 81 |
| Figure 5.7 | Total bruise volume versus coefficient of restitution during the free impact of apple-to-apple | 82 |
| Figure 5.8 | Contact area versus coefficient of restitution | 83 |
| Figure 6.1 | Largest bruise area after skin removal on either of two colliding apples plotted against two-fifths power of impact energy for Splendour apples | 93 |
| Figure 6.2 | Largest bruise area on either of two colliding apples plotted against contact area for Splendour apples | 95 |
| Figure 6.3 | Largest bruise area on either of two Splendour apples in apple-to-apple impact plotted against peak acceleration recorded by the Instrumented Sphere when dropped from the same height | 98 |
| Figure 7.1 | Different impact surfaces selected from local fruit grader manufacturer | 106 |
| Figure 7.2 | Wall pendulum system used in this experiment | 107 |
| Figure 7.3 | Plastic bar fixed onto the impact board | 108 |

- Figure 7.4 Largest bruise area on either apple versus two-fifth power of impact energy for Splendour apples 111
- Figure 7.5 Bruise area versus peak acceleration recorded by Instrumented Sphere during impacts of Splendour apples onto a flat steel surface 114
- Figure 7.6 Surface response lines for different surfaces tested 116
- Figure 7.7 Bruise boundary for Gala apples 118
- Figure 7.8 Bruise boundary for Splendour apples 118
- Figure 7.9 Bruise boundary for Braeburn apples 119
- Figure 7.10 Bruise boundary for Fuji apples 119
- Figure 7.11 Bruise boundary for Granny Smith apples 120
- Figure 7.12 Bruise boundaries for different varieties tested 123
- Figure 8.1 Linear relationship between total bruise volume (cm^3) of the two fruit and energy absorbed (J) during apple-to-apple impacts for Granny Smith in the 1990 season 128
- Figure 8.2 The linear relationship between total bruise volume of the two fruit and energy absorbed during apple-to-apple impacts for Granny Smith apples after 14 days storage 128
- Figure 8.3 The linear relationship between total bruise volume of the two fruit and energy absorbed during apple-to-apple impacts for Granny Smith apples after 44 days storage 129
- Figure 8.4 The linear relationship between total bruise volume of the two fruit and energy absorbed during apple-to-apple impacts for Granny Smith apples after 220 days storage 129
- Figure 8.5 Bruise susceptibility (cm^3/J) of Granny Smith apples at different storage times 130
- Figure 8.6 Ratio of the larger bruise area of the two fruit to $2/5$ power of impact energy ($\text{cm}^2/\text{J}^{2/5}$) during the impacts of Granny Smith, Splendour, Fuji, and Braeburn onto different surfaces

| | | |
|-------------|---|-----|
| | in the 1991 season | 133 |
| Figure 8.7 | Ratio of bruise area to $2/5$ power of impact energy for Granny Smith apples at different times in storage | 135 |
| Figure 8.8 | Ratio of bruise area to $2/5$ power of impact energy ($\text{cm}^2/\text{J}^{2/5}$) of Splendour during the impacts of fruit-to-steel and fruit-to-fruit at different times in storage in the 1991 season . . . | 136 |
| Figure 9.1 | Ball drop test | 141 |
| Figure 9.2 | Pendulum device designed for determining Bruise Factors | 143 |
| Figure 9.3 | Simplified pendulum system | 144 |
| Figure 9.4 | Fruit and fruit cutter | 147 |
| Figure 9.5 | Fruit after cutting | 148 |
| Figure 9.6 | Starch index for Gala apples | 150 |
| Figure 9.7 | Bruise factor measured by the new approach and the number of bruises by fruit grader for Gala apples at different temperatures | 152 |
| Figure 9.8 | Bruise susceptibility (cm^3/J) obtained by ball drop test | 153 |
| Figure 9.9 | Standard measurements of starch test on Gala apple at different temperatures | 154 |
| Figure 9.10 | Fruit firmness of Gala apples at different temperatures measured by penetrometer | 154 |
| Figure 9.11 | Measurements of Brix of Gala apples at different temperatures by refractometer | 156 |
| Figure 9.12 | Bruise factors and the total number of bruises produced by the fruit grader for different varieties | 157 |
| Figure 9.13 | Starch tests of Granny Smith apples at different harvest dates | 158 |
| Figure 9.14 | Bruise Factors of Granny Smith apples at different harvest dates | 159 |

LIST OF TABLES

| | | |
|------------|---|-----|
| Table 2.1 | Bruise susceptibility at different times of storage | 16 |
| Table 3.1 | Styles of fruit bruising appearance | 39 |
| Table 6.1. | Linear relationship between the contact area and two-fifths power of impact energy for different varieties of apple | 93 |
| Table 6.2. | Linear relationship between the bruise area and two-fifths power of impact energy for different varieties of apple | 94 |
| Table 6.3. | Linear relationship between the bruise area and contact area for different varieties of apple | 96 |
| Table 6.4. | Linear relationship between the velocity change and peak acceleration recorded by Instrumented Sphere during impact onto Gala, Splendour, Braeburn, Fuji, and Granny Smith apples | 97 |
| Table 6.5. | Linear relationship between bruise area and peak acceleration and bruise thresholds for fresh Gala, Splendour, Fuji, Braeburn, and Granny Smith apples in 1991 season | 99 |
| Table 7.1. | The average weight and the range of weight used for different varieties | 110 |
| Table 7.2. | Linear relationship between the largest bruise area and two-fifths power of impact energy for different varieties | 113 |
| Table 7.3 | Relationship between bruise area and peak acceleration recorded by the Instrumented Sphere. Fruit and Instrumented Sphere were dropped from the same height. Figures in brackets are coefficients of determination (R^2) | 115 |
| Table 7.4 | The linear relationship between the velocity change and peak acceleration recorded by IS during the impacts of IS onto Gala, Splendour, Braeburn, Fuji, and Granny Smith apples . . | 117 |

ABSTRACT

Mechanical handling subjects fruit to impacts which often cause bruising. Such bruising is a major source of quality loss in the fruit industry. In this study, a range of experiments was carried out to investigate the quantification of bruises and the prediction of bruising in relation to mechanical handling systems.

In order to understand apple bruising, a study of free normal impact between pairs of apples was conducted. There was a $2/5$ power relationship between contact area and impact energy. The coefficient of restitution varied in a non-linear manner with impact energy, decreasing as impact energy increased.

Bruise damage produced by a typical New Zealand-made fruit grader was critically analysed. A large percentage of individual bruises was under 1 cm^2 in area and it was rare to have any bruises above 3 cm^2 . The total number of bruises was found to be the best indicator of bruise susceptibility. A new method of predicting such bruises has been developed involving a new term, the Bruise Factor, which was related to bruising sustained during handling operations, allowing for the variation in fruit size, shape and mass.

An Instrumented Sphere (IS) was used to characterize impacts on commercial packing lines. It was found that the IS could be used to identify apple-to-apple impacts likely to cause bruising in commercial packing operations, providing care is taken with interpretation of the data. Typical impacts on packing lines were represented by impacts onto a flat steel surface, a rubber pad, a plastic tube, a solid plastic bar, and onto another fruit. Impact tests were conducted on freshly picked Gala, Splendour, Fuji, Braeburn, and Granny Smith apples, all grown in Hawkes Bay, New Zealand. Bruise areas produced by impact onto flat steel, rubber, plastic tubing, and a solid plastic bar were found to be linearly correlated with the peak

acceleration recorded by an Instrumented Sphere dropped from the same heights.

Following fruit-to-fruit impacts, bruising was generally more severe on one of the two apples. When the results of apple-to-apple and IS-to-apple impacts were compared, it was found that the area of the larger of the two bruises produced in fruit-to-fruit impacts was directly related to the peak acceleration recorded by the IS when it was dropped onto a fruit from the same height.

For each variety and each surface the drop height required to produce a critical bruise with a surface area of 1 cm² (as measured with the skin removed) was determined. By joining the threshold points on each surface response line, a threshold potential bruise boundary was formed on a velocity change against peak acceleration graph. The boundary curve, which included apple-to-apple impact, was hyperbolic in shape, rather than the linear boundary described in other studies.

The implications of the results to the fruit industry are discussed in this study.

1. GENERAL INTRODUCTION

Pipfruit, which include apples and pears, is one of New Zealand's most successful horticultural industries. In 1990-1991 season the industry had 19.5 million cartons of apples and 0.5 million cartons of pears, with a record turnover of \$541 million, of which \$403 million was exported as fresh fruit (New Zealand Official Yearbook, 1992). Fresh apples thus comprise an important part of New Zealand's exports.]

The apple harvest season in New Zealand runs from February to May. Most fruit are picked by hand and then transported by truck or forklift to local packing sheds or pre-coolers. Fruit are inspected, sorted, and graded using mechanical equipment and packed into cardboard cartons. Finally the New Zealand Apple and Pear Marketing Board handles transport and marketing operations for growers. The quality of fruit plays an important role in maintaining the Board's success. The marketing system directly rewards growers with higher prices if the quality is higher. On the other hand, growers can be penalized for low quality fruit. For example, the apple industry lost about \$10 million potential income from Granny Smith apples alone in the 1991 season because of down grading due to bruising (Banks, 1991).

A few decades ago Gaston and Levin (1951) reported that on average more than a third of the apples offered for sale in Michigan's retail stores were badly bruised by the time consumers saw them. To date the primary cause of quality loss and grade reduction in apples destined for the fresh market is still bruise damage (Marshall and Burgess, 1990). Such bruising or grade reduction results in a much lower market price because the fruit is unappealing to consumers. There are three main sources of mechanical damage to fruit: impact damage resulting from a mechanically applied force or free falling against a hard surface or another fruit; compression damage resulting from excessive pressure; and vibration damage resulting from repeated and prolonged vibration of the fruit during transport and

handling operations. Impact bruising can occur at any step in the fruit handling system from harvesting through to the consumer, and it remains the major source of mechanical damage.

[There are three ways to assess mechanical bruise damage of apples: bruise area, bruise volume, and number of bruises (Siyami et al., 1988). Bruise area and bruise volume have been commonly used by previous researchers and quality controllers, but little work on the importance of the number of bruises has been found in the literature. Apple sales depend to a considerable extent on appearance, and several small bruises can make the apples less attractive to the consumers (Gaston and Levin, 1951). The appearance could be influenced by the number of bruises as much as the absolute bruise size. Maintaining high quality standards involves the rapid inspection and removal of bruised fruit, and the avoidance of subsequent damage to the fruit after inspection.]

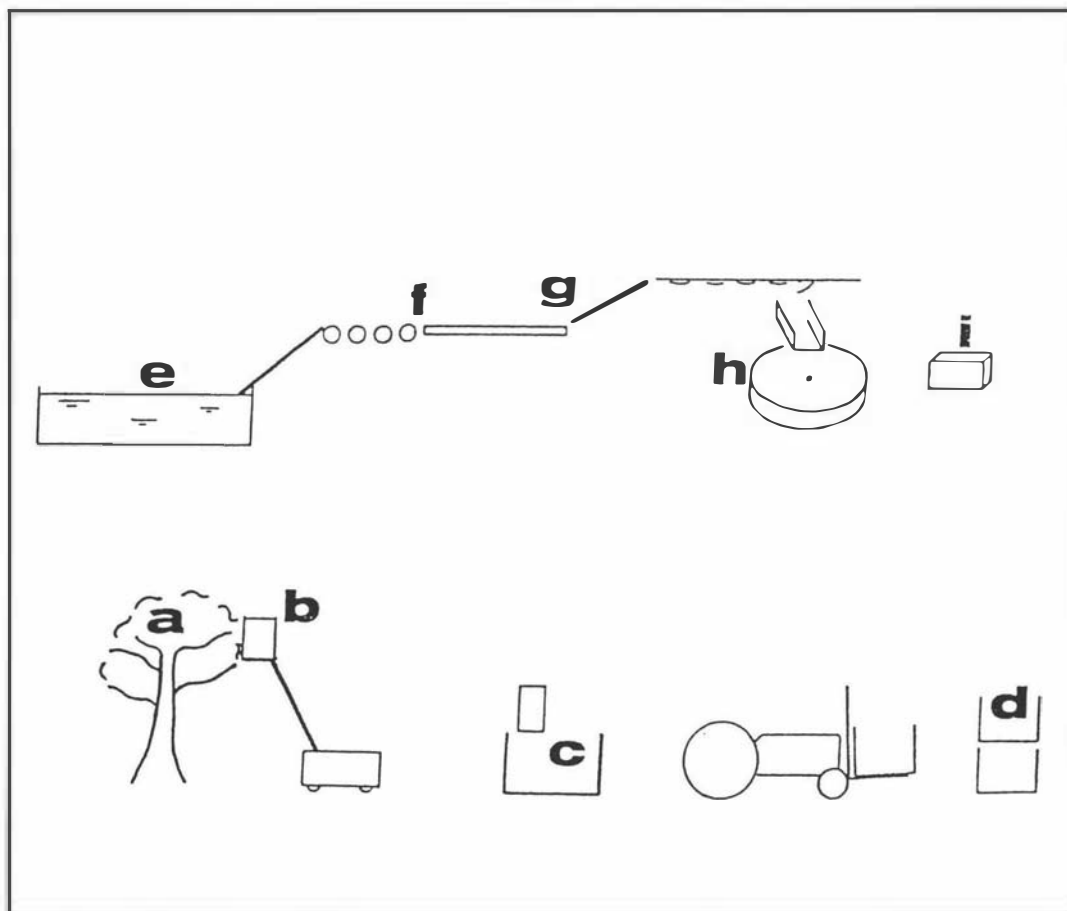

Figure 1.1 A typical New Zealand fruit handling chain. a: directly from tree, b: picker's bag/bucket/hydra-lada, c and d: bins, e: water dump, f: after green brushes, g: sorting table, h: final size bin, i: apple carton (source: Studman, 1990).

A typical handling system is shown in Figure 1.1. Fruit are commonly harvested by hand, pickers use ladders to reach the fruit. Fruit are placed into a wooden box about 1.2 m square by 0.8 m deep. The filled bins are transported from the orchard by tractor-mounted forklift and taken either directly to the packing shed or into pre-coolers. Trucks are used for off-orchard transportation. Fruit are sorted, graded, and packed into cardboard cartons in the packing shed (Studman, 1990).

After studying 8 typical packinghouses in the United States, Brown et al. (1987) found that only 11% of Golden Delicious apples remained unbruised after

completing the packing operation. With the new technology and export-oriented market of fresh fruit, great care has been taken in the fruit industry in recent years, particularly in designing new packing machines or maintaining old fruit packing lines: drop heights of apples have been reduced as much as possible, and possible impact points have been well-padded. Surveys of New Zealand grading equipment (Banks, 1991) suggested that the drop heights involved did not exceed 30 cm and the damage caused by a large drop appeared to be less than might have been expected because of padding. In contrast, small drops onto hard surfaces and apple-to-apple impacts caused more bruises which still exceeded the commercial standard of bruise size for export. Therefore fruit-to-fruit impacts during fruit handling and the total number of bruises produced by the systems are equally important factors governing fruit quality, which should be fully studied and explored.

(Bruising can occur at any point and it is vital to be able to correct any problem which arises during the handling process. Since machines, fruit properties, and people's carefulness all alter with time, it is necessary to monitor performance continuously. In-shed quality assurance procedures are intended to achieve this. However, in order to help growers and packers to improve fruit quality, it is advantageous to understand the mechanism of fruit bruising, and to develop techniques for the rapid assessment of bruise damage produced in postharvest handling procedures, particularly during harvesting and packaging when time is short. To achieve this, methods of predicting and quantifying fruit bruise damage must be developed.)

(The apple industry is particularly concerned about fruit damage during handling and transport operations. Bruise damage usually results when an apple impacts either a hard surface or another fruit. Fruit quality is normally influenced by bruise size, bruise depth, and the number of bruises. Bruise depth can only be measured by

cutting the apple, which is a time consuming process and is generally used only by researchers. The bruise area on the apple surface and the number of bruises are the main factors used by fruit inspectors and consumers when determining the extent of bruise damage. Many studies have been carried out for minimizing the bruise damage by means of bruise size (Chen and Sun, 1981; Siyami et al., 1988; Brown et al., 1990; Marshall and Burgess, 1990). A reduction in damage, however, can only be achieved if all factors governing susceptibility of fruit to bruising in a realistic situation are well-understood (Klein, 1987).

The impact loads during fruit handling operations are extremely difficult to detect and measure. Since the 1970's, impact detection devices have been developed to study fruit damage. Instrumentation techniques have been described for measuring and recording the force-deformation relationships of apples by Finney and Massie (1975). Others who have developed impact-measuring pseudo-fruit include Jenkins and Humphries (1982), Aldred and Burch (1977), and Halderson et al. (1983). Recently, a new generation of devices have been developed, such as the "Electronic vegetable" by Anderson and Parks (1984), and the Instrumented Sphere by Brown et al. (1987). The devices do not attempt to indicate whether fruit will be bruised but rather give a "damage potential level" during a handling procedure. This is because fruit damage susceptibilities vary between cultivars, different impact materials and surface geometries. Although some work has been done about the relationship between fruit bruising and the output of impact detection devices, it still requires some synthesis of information to gain a better understanding of the mechanism of apple-to-apple impact and the response of apples to different impact surface geometries.

The objectives of this study were as follows:

1. To investigate different impact situations on typical New Zealand apple

packing lines.

2. To analyze the mechanism of apple-to-apple impacts related to fruit handling operations.
3. To examine impact dynamics and to quantify fruit bruise damage at different impact energy levels, striking surfaces of various shapes and mechanical properties.
4. To produce a method of predicting bruise potential of fruit packing lines by using an Instrumented Sphere, which could also be used as a guideline for design, testing, and setting of new grading machines or other handling equipment.
5. To examine methods of determining fruit bruise susceptibility .
6. To develop a new approach for assessing bruise damage which correlates closely with the actual damage produced by a handling operation.
7. To determine the effects of temperature and time of harvest on bruise damage using the new approach to assessing bruise damage in apples.

There are ten main Chapters in this thesis. Previous research work related to the measurement of bruising on apple fruit is reviewed in Chapter 2. Chapter 3 deals with the investigation of the bruising phenomena related to fruit packing lines in order to give a basic understanding of bruising produced by a mechanical handling system. The use of an Instrumented Sphere (IS) is described in Chapter 4. Apple-to-apple impacts are considered as a major source of bruising in Chapter 5.

The Instrumented Sphere has been developed as a useful tool to predict bruise levels during handling operations. However, previous interpretations of its output do not include fruit-to-fruit impacts, and so experiments were carried out to explore the ability of the IS to predict bruising during fruit-to-fruit impacts; these are described in Chapter 6. In Chapter 7, a revised bruise threshold for the IS is developed.

Methods of determining bruise susceptibility are assessed in Chapter 8 and a new approach to assessing fruit bruising produced by fruit handling systems is developed in Chapter 9. Chapters 10 and 11 include an overall discussion and conclusions.

2. REVIEW OF LITERATURE ON BRUISE ASSESSMENT AND OCCURRENCE

2.1 Introduction

Apple bruising as a result of impact during harvesting, packing, transporting, and handling of fruit is a complex phenomenon which has been identified as a major source of quality loss in the fruit industry. The need to understand the factors influencing such phenomena has led many researchers to investigate the mechanical damage problems of fruit (e.g. Mohsenin, 1984; O'Brien et al., 1973; Holt and Schoorl, 1977; Chen and Yazdani, 1991; Horsfield et al., 1972; Brown et al., 1990). In this Chapter a range of previous research related to methods of determining fruit bruising, theoretical analyses and practical studies of apple impacts, and handling procedures is reviewed and discussed.

2.2 Determination of apple bruising

There is no standard method for measuring bruise damage, and consequently researchers have often designed their own procedures (Manor, 1978).

Mohsenin (1970) defined the bruise volume (V_b , mm^3) with the assumption that the shape of the bruise is spherical as :-

$$V_b = \frac{\pi d}{24} (3D^2 + 4d^2) \quad \text{.....(2.1)}$$

where d is the depth of bruise at the centre and D is the surface diameter of the bruise (mm).

Holt and Schoorl (1977) assumed that the shape of the bruise is spherical above and below the contact plane. The volume of bruise above the contact plane, V_2 and below V_1 are shown in Figure 2.1. Total bruise volume, V_b , of the bruise is then given by:

$$V_b = V_1 + V_2 = \frac{\pi h_b}{24} (3D^2 + 4h_b^2) + \frac{\pi X}{24} (3D^2 + 4X^2) \quad \dots(2.2)$$

where X is the height of the bruise above the contact plane and can be calculated from:

$$X = R - \sqrt{R^2 - \frac{D^2}{4}} \quad \dots\dots(2.3)$$

where R is the radius of the apple.

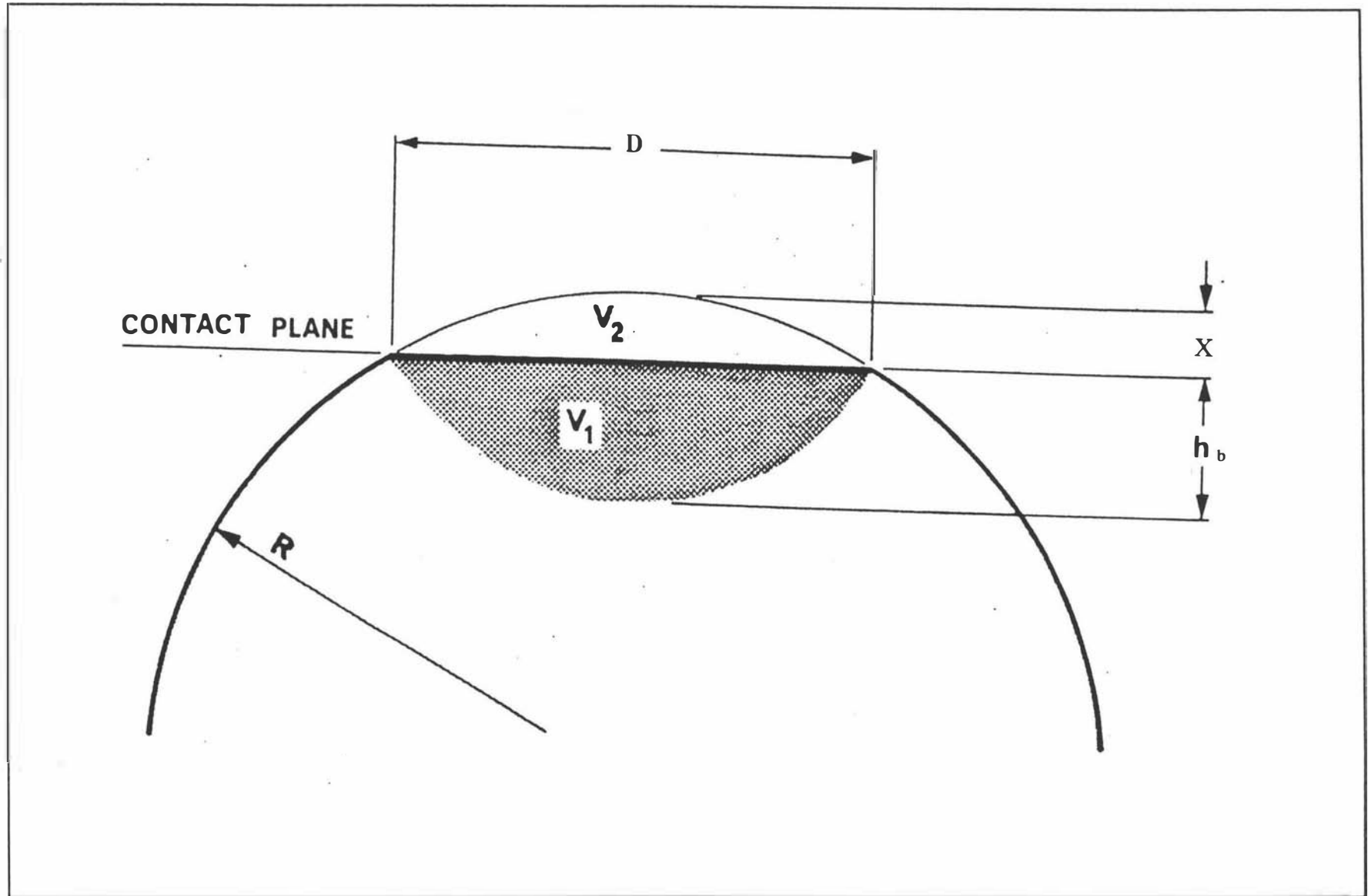

Figure 2.1 Cross-section of idealized bruise showing symbols used by Holt and Schoorl (1977)

Diener et al. (1979) calculated the bruise volume V_b as a partial sphere:-

$$V_b = \frac{\pi d}{6} (0.75 D^2 + d^2) \quad \text{.....(2.4)}$$

Where d is the depth of bruise centre and D is surface diameter of the bruise.

A more simple formula was used by Chen and Sun (1981). The degree of bruise was evaluated by cutting through the centre of the bruise region and measuring the maximum width and depth of bruise with a scale. The shape of the bruise was assumed to be a semi-oblate spheroid, for which the bruise volume, V_b , is given by:

$$V_b = \frac{1}{6} \pi d D^2 \quad \text{.....(2.5)}$$

where d and D are also the depth and width of bruise respectively.

In the fruit industry, a simpler way has been developed using bruise volume factors (New Zealand Apple and Pear Marketing Board, 1982). The bruise volume is calculated by multiplying bruise diameter by a bruise volume factor dependent on the range of bruise diameter. The factors were obtained experimentally from measurements of a range of bruises and were believed to provide a useful and consistent scale for indicating bruise damage.

Bruise diameter both with skin on and skin removed are important variables which have been used in many studies using the Instrumented Sphere (e.g. Sober et al., 1989; Brown et al., 1990). Bruise size with skin on is usually used by the fruit industry. The New Zealand Apple and Pear Marketing Board allows any bruise area less than 100 mm² to be ignored for export if the accumulated bruise area on one apple is not more than 100 mm². The U.S. Grade Standards (Brown et al., 1990) allow one bruise less than 198 mm² area to be ignored if it is not readily

visible. However they found that bruises between 32 and 127 mm² in area were often visible, and when accumulated could easily exceed the 127 mm² limit required for the Extra Fancy Grade. However, they also pointed out that when the apple was peeled, even bruises of 32 mm² area resulted in brown tissue which could be objectionable to the consumer.

2.3 Bruise susceptibility

Bruise susceptibility has been defined as the change in measured bruise volume corresponding to the energy absorbed during either mechanically applied compression or resulting from free fall impacts onto a given surface (Holt and Schoorl, 1977; Brusewitz and Bartsch, 1989; Garcia et al., 1988). Some differences in apple bruise susceptibility have been found in the literature due to unstandardized impact energy levels and surfaces used for the impacts. In this section, the methods of determining bruise susceptibility in previous research work will be discussed.

2.3.1 Methods of determining bruise susceptibility

While there is not a standard method for determining bruise susceptibility, Schoorl and Holt (1980) suggested the use of a bruise resistance coefficient defined as the ratio of the bruise volume to the energy absorbed in the impact. This method is based on an assumed linear relationship between bruise volume and energy absorbed in an impact. The energy absorbed during an impact can be obtained by dropping a single apple onto a solid surface and recording drop and rebound heights. The energy absorbed is given by:

$$E_a = mg (H - H_1) \quad \text{.....(2.6)}$$

where E_a is the energy absorbed (J), m is the mass of apple (kg), g is the gravitational constant (9.81 m/s^2), H and H_1 are drop height and rebound height respectively (m).

The method of taking measurements and the formulas for calculating the bruise volume are described by Holt and Schoorl (1977).

For using this method, a series of impact tests must be carried out to obtain the correlation between the energy absorbed and the bruise volume. The relationship is of the form $V_b = k_1 E_a + k_2$ where the intercept, k_2 , is usually small. The susceptibility, k_1 , is found from curve fitting. At least 10 tests are required to give an estimate of the bruise resistance coefficient.

There appear to be two problems in using this method in practice: It is difficult to determine the rebound height and bruise volume measurement is a time consuming process.

The relationship between bruise size and various impact parameters were also studied by Brusewitz and Bartsch (1989) to quantify the change of bruise size with the change of impact parameters. Fruit was dropped onto a force transducer from drop heights ranging from 0 to 40 cm. Impact peak force, time duration, time to peak force, impulse, apple diameter and mass were measured during the tests. The bruise volume was calculated from bruise depth, bruise diameter, and fruit diameter assuming a spherical bruise shape as described by Mohsenin (1970). Change in bruise volume per unit change in energy absorbed (bruise susceptibility, cm^3/J) tended to decrease with storage time. In contrast, Holt and Schoorl (1984) found no statistically significant change in bruise susceptibility with storage time. The

change in bruise volume per unit change in impact energy appeared to increase with storage time, and there was a non-linear relationship between peak force and time of the impact. It was concluded that the value of peak impact force to time to peak force may be a parameter which was sensitive to firmness changes but less variable than other impact parameters.

Studman and Banks (1990) conducted experiments on Nashi and apples to identify a quick and easy method of measuring the bruise susceptibility of apples. It was suggested that a surface measurement method could be more useful for rapid field work than the measurement of bruise volume. Fruit were struck by one of four different metal indenters mounted on a pendulum. The indenters consisted of a ball of 25.4 mm in diameter, a flat plate, and two cones with vertex angles of 150° and 130° , all of the same mass. Contact diameters were measured by inking the indenter before the impact. Conical indenters produced a more nearly linear relationship between impact energy and contact area than using a flat or spherical indenter.

For fast assessment of bruise susceptibility in the field, a steel ball was dropped from a given height down a vertical tube giving a impact energy of 0.3 J (Banks, 1990). Bruise area or bruise volume with this standard impact energy could be used as measures of bruise susceptibility. Saltveit (1984) used a similar method to determine the effects of temperature on apple bruise susceptibility. A 500 g brass cylinder (3.5 cm diameter x 6 cm) was dropped from a height of 10 cm. A paper tube guided the fall of the cylinder so that the impact was always perpendicular to the surface of fruit. Bruise volume was used to indicate the bruise susceptibility.

Although there are many different methods to measure the bruise susceptibility, none of the test methods gives satisfactory results which are in agreement with commercial experience (McLeod, 1992). For commercial purposes, fruit is graded

and sold on its appearance, and the apparent surface area of a bruise and the number of bruises on a fruit are more critical than the bruise volume. Consumers may not be concerned with the volume of bruises.

2.3.2 Application of bruise susceptibility

Apple bruises can be produced at any stage of harvest, handling, and transportation.

reduces Fruit temperature, maturity of the fruit, and the time in storage may vary considerably. [Maintenance of the high quality of fruit may be achieved by either decreasing fruit bruise susceptibility or increasing the standards of handling operations. Alternatively, if the way in which bruise susceptibility varies with these factors is known, then bruising can be reduced if fruit are handled only when their bruising susceptibility is low.] Consequently there is a need for reliable measures of bruise susceptibility at different harvest times, in different temperatures, and at different storage times.

Hyde and Ingle (1968) conducted an experiment in which an object weighing 373 g was swung through an arc of 16° on a radius of 112.5 cm impacting onto 'McIntosh', 'Jonathan', 'Golden Delicious', 'Delicious', 'Stayman', and 'Rome' apples. Bruises were evaluated after thirty minutes. Each fruit was cut vertically through the centre of the bruise, and diameter and depth of brown tissue were measured. In their study, bruise width and depth were considered separately. The results showed that bruise size was affected by cultivar, maturity and length of time in storage. Bruise size increased with advancing preharvest maturity but decreased with increasing storage time prior to bruising.

Schoorl and Holt (1977) studied 'Jonathan', 'Delicious', and 'Granny Smith' apples. An experiment was conducted to measure the correlation between bruise volume

and energy absorbed at different times in storage using a metal projectile to produce impact energies ranging from 0.35 to 2.0 J. In the second season, only impacts of about 1.25 J were used to bruise the fruit. The results are summarised in Table 2.1. In the first season, bruise susceptibility was obtained from the slope of the graph of bruise volume against energy absorbed. In the second season, bruise susceptibility was the ratio of bruise volume to the energy absorbed from only one level of impact.

Table 2.1

Bruise susceptibility (cm^3/J) at different times of storage (1975 season)

| Variety | Storage until | Bruise susceptibility (first season) | Bruise susceptibility (second season) |
|--------------|---------------|--------------------------------------|---------------------------------------|
| Jonathan | April | 4.7 | 5.5 |
| | June | 6.3 | 8.5 |
| | August | 8.2 | 12.5 |
| Delicious | April | 5.1 | 6.5 |
| | June | 7.1 | 7.7 |
| | August | 7.5 | 10.1 |
| Granny Smith | April | 6.1 | 6.4 |
| | June | 5.2 | 7.1 |
| | August | 5.9 | 7.7 |

From the table, it can be seen that there was a marked increase in bruise susceptibility with storage time for 'Jonathan' and 'Delicious' apples. The bruise susceptibility values for the same variety of apples determined by two different methods were different, but this may have been due to differences in bruise susceptibility of the fruit in the two years. The bruise susceptibility obtained in the second season from one energy level of impact may be a poorer estimate of susceptibility to bruise damage assuming that the statistical value from a group of

measurements gives a more reliable indication of the degree of bruise damage.

Following the above study, another experiment was carried out by Klein (1987) on New Zealand 'Gala' and 'Granny Smith' apples to determine the effect of harvest date and length of time in storage. Apples were bruised once by dropping them on their cheek from 10 or 40 cm onto a wooden table surface. After the first impact the apple was caught by hand to avoid a second impact. Bruises were allowed to develop for 12 to 24 hours at 18°C and then were cut through the bruise along the stem-calyx axis. The radius of apple and the diameter and depth of the browned area of the bruise region were measured to calculate bruise and fruit volume, after which the browned tissue was excised and weighed. The percentage of total individual fruit weight or volume was taken as a parameter to express bruise susceptibility.

In the results, bruise susceptibility increased with lateness of harvest and decreased over storage time. The storage period appeared to be more significant than harvest date in governing susceptibility to damage. Fruit temperature at impact or during subsequent bruise development had no effect on bruise susceptibility of either 'Granny Smith' or 'Gala' apples. It was also found that the absolute bruise volume and weight were greater in both large-sized 'Gala' and 'Granny Smith' apples than in smaller fruit. When bruising was expressed as a percentage of fruit volume or weight, however, there was no difference attributable to fruit size. Small fruit seemed to have a greater percentage of damaged tissue than large fruit.

In contrast, Diener et al. (1979) found a decrease in bruise susceptibility as the apples approached maturity. There was a clear reduction in bruise volume when Golden Delicious apples were dropped from 10-35 cm heights onto a rigid surface as the apples matured over a 27 day period.

Saltveit (1984) used an Effegi pressure tester with a 1.1 cm diameter plunger and a drop tester to determine the temperature effects on bruise susceptibility of Starkrimson Delicious and Golden Delicious apples. The results showed that the firmness of these two varieties were not significantly different when tested at 0° and 20° C after 26 weeks of storage at 0° C. The bruise volume increased with increasing temperature when injured and with increasing holding temperature during bruise development.

Many other studies have been conducted on the effects of temperature, although the terminology of bruise susceptibility was not formally used (e.g. Mohsenin, 1970; Nelson and Mohsenin, 1968). Bruise susceptibility has also been determined for other fruit (eg. Brusewitz et al., 1991, on peaches).

2.4 Theoretical analysis of fruit impact

2.4.1 Hertz contact theory for fruit impact

The fundamental assumptions for the contact of two spheres as discussed by Kosma and Cunningham (1962) and Horsfield et al. (1972) are that the materials of the contacting bodies should be elastic and homogeneous.

There is some debate as to whether elastic theory can be applied to fruit, since most fruits exhibit viscoplastic behaviour, and are also anisotropic. However, Lee and Rodak (1960) have shown that if the loading times are less than one-fourth the relaxation time, viscoelastic materials behaving as simple Maxwell bodies can be considered essentially elastic. Horsfield et al. (1972) also suggested that under impact loading, the loading time was short enough to assume elastic behaviour in apples, at least up to failure. This view was supported by Chen et al. (1985) for a

range of fruits, such as peaches, pears, and apples, while Mohsenin (1970) pointed out that despite the obvious inconsistencies, the relative simplicity of the Hertzian elastic solution, and the fact that the method provides good correlation with experimental results, have been the main reasons for the extensive use of this approach.

The elastic theory for two impacting spheres was described by Timoshenko and Goodier (1970). During the impact of two spherical bodies, the approach, α , of the spheres at the point of maximum compression can be expressed by:

$$\frac{1}{2}V^2 = \frac{2}{5}n n_1 \alpha^{5/2} \quad \text{.....(2.7)}$$

where V is the velocity of approach of the two spheres at the beginning of impact, and where

$$n_1 = \frac{m_1 + m_2}{m_1 m_2} \quad \text{.....(2.8)}$$

$$n = \left(\frac{16R_1 R_2}{9\pi^2 (R_1 + R_2) (K_1 + K_2)^2} \right)^{1/2} \quad \text{.....(2.9)}$$

where m_1 is the mass of first sphere, m_2 is the mass of second sphere, R_1 is the radius of first sphere, and R_2 is the radius of second sphere, and where

$$K_1 = \frac{1 - \nu_1^2}{\pi E_1} \quad K_2 = \frac{1 - \nu_2^2}{\pi E_2} \quad \text{.....(2.10)}$$

where ν_1 is the Poisson's ratio of the first sphere, ν_2 is the Poisson's ratio of second sphere, E_1 is the modulus of elasticity of first sphere, and E_2 is the modulus of

elasticity of second sphere.

During impact the radius of the contact surface of the two spherical bodies, a is given by:-

$$a = \frac{\pi^2}{2} p_o \frac{R_1 R_2}{R_1 + R_2} (K_1 + K_2) \quad \dots(2.11)$$

where P_o is the pressure at the centre of the contact area. The approach of the two bodies is given by:-

$$\alpha = \frac{\pi^2 a}{2} p_o (K_1 + K_2) \quad \dots(2.12)$$

Equation (2.11) and (2.12) result in:

$$\alpha = a^2 \frac{R_1 + R_2}{R_1 R_2} \quad \dots(2.13)$$

Then equation (2.7) and (2.13) result in:

$$a^5 = \frac{15\pi}{16} \frac{V^2 m_1 m_2}{m_1 + m_2} \left(\frac{R_1 R_2}{R_1 + R_2} \right)^2 (K_1 + K_2)$$

Application of these relationships leads to the following results:

Assuming $u_1 = u_2 = u$,

$$a = \left(\frac{15}{8} (1 - v^2) \right)^{1/5} \left[\frac{m_1 m_2 V^2}{2(m_1 + m_2)} \right]^{1/5} \left(\frac{R_1 R_2}{R_1 + R_2} \right)^{2/5} \left(\frac{E_1 + E_2}{E_1 E_2} \right)^{1/5} \quad \dots(2.15)$$

$$A = \pi \left(\frac{15}{8} (1 - v^2) \right)^{2/5} \left[\frac{m_1 m_2}{m_1 + m_2} gh \right]^{2/5} \left(\frac{R_1 R_2}{R_1 + R_2} \right)^{4/5} \left(\frac{E_1 + E_2}{E_1 E_2} \right)^{2/5} \quad \dots(2.16)$$

where A is the area of contact surface during impact (m^2), h is the drop height (m), and g is the acceleration due to gravity (9.81 m s^{-2}).

2.4.2 Bruise prediction models

Experiments were conducted by Siyami et al. (1988) to compare the actual bruises obtained from an impact table with the predictions of different models. The results are discussed in the following sections.

(a) Adjusted Hertz theory

To extend the Hertz equations to the viscoelastic case, Hamann (1970) introduced the uniaxial stress-strain relation, which is a function of the rate of loading. This implied that a time dependent modulus of elasticity, rather than a constant value, could be used for apples. The prediction model was expressed as follows:

$$BDAH = (BD) \lambda$$

Where $BDAH$ is the adjusted Hertz bruise diameter (mm), BD is bruise diameter calculated from Hertz's theory (mm), and the ratio λ is a time-based adjustment factor which varies with impact conditions. It is dependent on the ratio of total velocity change to maximum acceleration (these terms are explained in Chapter 4).

(b) Plastic theory

When the force-deformation curve exceeds the bio-yield point, apple tissue starts to fail, and the elastic relationships no longer apply in the region of bruise development. Siyami et al. (1988) suggested that a limiting plastic stress may provide a good prediction, given knowledge of the Magness-Taylor force, apple diameter, apple weight and drop height. When a falling apple strikes a flat hard surface, forces acting on the contacting surface compress the tissue to a maximum when the apple radius and maximum compression are known. Assuming that all points on the contact surface are yielding, and that the only forces acting on the apple are the contact force and the apple weight, then the bruise diameter is given by:-

$$BD = 5.63 \left(\frac{h W D_a}{F} \right)^{1/4} \quad \text{.....(17)}$$

Where BD is bruise diameter (mm), h is drop height (mm), W is apple mass (kg), D_a is apple diameter (mm), and F is Magness-Taylor force (kg/mm²).

(c) Multiple linear regression analysis

An alternative model was to suggest that apple diameter, apple mass, Magness-Taylor force (apple firmness) and impact velocity (drop height) were key variables for predicting bruise diameter.

In an attempt to include all of this information in a model that predicts bruise diameter using the measured data, a stepwise multiple linear regression analysis was

performed by Siyami et al. (1988) using bruise diameter as the dependent variable. The independent variables included were apple diameter, apple weight, Magness-Taylor force, maximum acceleration during impact, and total velocity change during impact. Prior to starting the regression analysis, the correlation coefficient matrix was calculated for all impact cases to determine which independent variables were highly correlated with bruise size and which were highly correlated with each other.

In comparing these models Siyami et al. (1988) found that Hertz elastic theory overestimated the measured bruise diameter by 25%. Adjusting the Hertz elastic prediction by a time factor related to viscoelastic impact conditions greatly improved the bruise diameter prediction. Plastic contact theory underestimated the bruise diameter by 20% for a 2 ms impact and both under and overestimated it for a 6 ms impact, so its predictions did not match the measured diameter. The multiple linear regression model based on apple diameter, Magness-Taylor force, maximum acceleration and total velocity change provided very good predictions of measured bruise diameter ($R^2=0.97$).

2.5 Impact detection devices and their implications

Many horticultural products can be damaged by mechanical handling systems. The bruise damage results in the loss of crop during sorting, grading, and packing. Worse still, bruising occurring during sorting, grading, and packing may not be detected at these stages, and may result in accelerated decay of the produce, rendering it unacceptable on arrival at markets and retail outlets.

The measurement of impact loads is extremely difficult, especially since the load is affected by the size and shape of the fruit itself. It is often very difficult to detect exactly where fruit is being bruised in a handling system, even though the damage

to fruit is evident from quality control checks. The problem is further complicated by the random nature of impact damage, and by variations in bruise susceptibility of the fruit itself.

Many impact detection devices have been developed to study damage to fruit. Instrumentation techniques have been described for measuring and recording the force-deformation relationships for apples by Finney and Massie (1975). Others who have developed impact measuring pseudo-fruit include Aldred and Burch (1977), Jenkins and Humphries (1982) and Halderson et al. (1983). Recently, a new generation of devices have been developed, such as the "Electronic Vegetable" by Anderson and Parks (1984) and the Instrumented Sphere (Brown et al., 1987). Both of these can be used to record impact loads on fruit during a handling operation, they are about the size of a round fruit, and can move freely through handling systems without the need for wires or radio communications. Although similar, the output of the two devices comes from different types of sensor, and the form of the output provided by the manufacturers differs.)

The 90 mm self-contained, microprocessor based Instrumented Sphere (IS) with tri-axial accelerometer was developed to record impacts experienced while being handled with fruits and vegetables. The device does not indicate directly whether fruit will be damaged but rather gives a "damage potential level" because of the unknown information about the relationship between the dynamics of impacts onto different surfaces and surface geometries and the response of fruit.

Anderson and Parks's Electronic Vegetable consists of four main components. An electronic package is used to measure, digitise, record and time the force measured by the sensing material; a hard shell provides a base for the sensing material; a piezoelectric sensing material gives the maximum force experienced through the handling operations; and a protective cover. Like the IS, the Electronic Vegetable

cannot indicate bruise levels in fruit directly.

2.5.1 Bruise prediction using an Instrumented Sphere

To correlate the IS output to bruise levels of fruit experienced during a handling operation, the IS is dropped from a range of drop heights onto a series of surfaces with increasing padding (Brown et al., 1990; Timm et al., 1989). For each selected impact surface, the points for different pulses on the graph of peak acceleration against velocity change can be joined together as a curve to represent the surface response line. When the variety of fruit under test is dropped from the same drop heights onto the same impact surface, the points on the response line which produce 0%, 10%, 50% and 100% bruise on fruit are taken as the threshold of bruising. When the tests are repeated for different padding surfaces, the lines joining the equal percentage of bruise on different response lines are then drawn to give a bruise envelope as shown in Figure 4.4. This means that any combination of peak acceleration and velocity change produced by the IS when it is run through a handling operation which lies to the right of the selected point on the response line produces unacceptable bruising.

2.6 Bruise boundary in packaging theory

In packaging theory, the bruise boundary is defined as the edge of a region where packaged products would not be damaged on a velocity change versus acceleration graph (Turczyn et al., 1986). The bruise boundary is normally formed by two lines which are parallel to the horizontal and vertical axis respectively. The positions of the lines are determined by experiment. Firstly, the velocity change remains unchanged and the acceleration is altered to determine the critical acceleration at which the product begins to fail, then a vertical line is drawn through the critical

points. Secondly, the velocity change is altered by using a special programmer at constant acceleration until the product fails. A horizontal line through the failure points on the graph and the vertical line then form a bruise boundary for that product.

2.7 Practical studies of apple packing lines

Mohsenin (1970) stated that one of the by-products of mechanization in production and handling of agricultural products has been mechanical damage to the crop. Many previous studies have been reported on minimizing apple bruising during sorting, grading, and packing (e.g. Gaston and Levin, 1951; Brown et al., 1987; Timm et al., 1989; Studman, 1990; Guyer et al., 1990; Sober et al., 1989). Research work has been done around the world on monitoring the bruise damage during mechanical operations to understand fruit impact problems related to commercial handling systems. Chen and Yazdani (1991) developed a method of predicting the bruises produced by fruit handling systems by using different instrumented artificial fruit. During the tests four different impact surfaces were used: 25.4 mm thick solid steel plate, 12.7 mm steel plate covered with a layer of 3.18 mm thick sponge cushion, steel plate with layer of 4.76 mm thick cushion, and steel plate with a layer of 6.35 mm thick cushion. Ten drop heights ranging from 2 to 40 cm were used. It was concluded that bruise volume could be predicted by multiple regression models based on the impact parameters and the acceleration histories of the impacts. The Fourier Transformed Acceleration Data was also used in the analysis. Bollen and Cox (1991) reported a technique to predict the proportion of product which is likely to sustain damage in a particular postharvest handling system based on the output data from an Instrumented Sphere. The model is based on the Poisson distribution and accounts for the distribution of typical impacts at each transfer point and the probability of fruit sustaining damage for each given impact. For understanding the bruises produced by a packing line, it is necessary to identify the sources of bruises

and the type of bruises on commercial packing equipment.

2.7.1 Apple damage assessment on American packing lines

Brown et al. (1987) carried out a study of typical American packing lines in a similar manner to that described above. Eight different packing lines were selected for the study and Golden Delicious apples were used in the test. The apples were hand picked and placed in standard paper pulp trays in the orchard to minimize the amount of bruising that might occur prior to the use of the test.

In each test, apples were placed in the water tank along with red apples during the normal operation of the packing line. Groups of apples were removed from the flow of fruit at different sites. The packing line was divided into five sections (Figure 2.2).

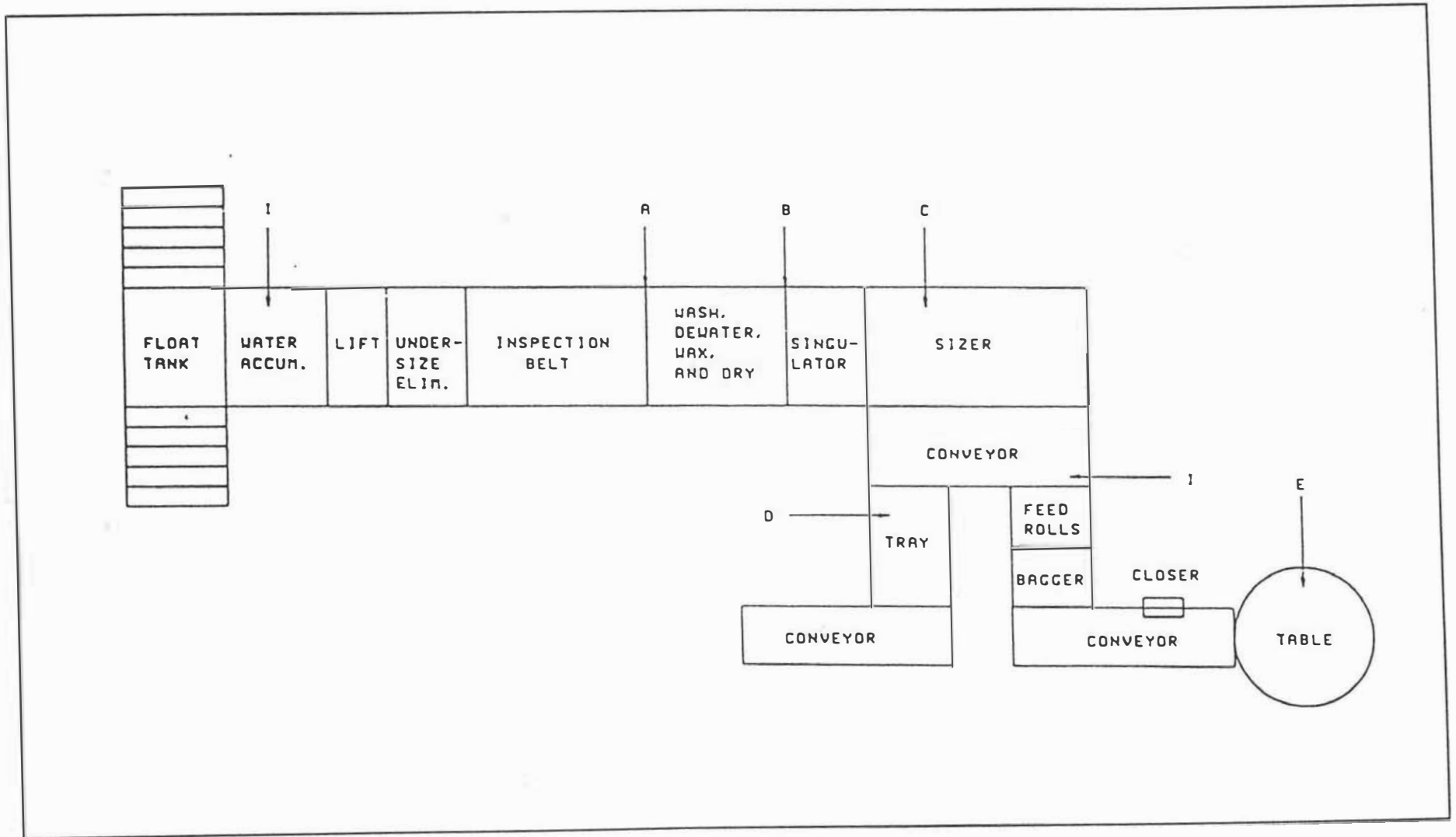

Figure 2.2 Sampling sites along packing line

- A. flotation tank, trash, undersize eliminator, and inspection belt.
- B. washer, dewaterer, waxer, and dryer.
- C. singulation system and transfer to the sizer.
- D. sizer drop-outs and takeaway conveyors.
- E. feed rolls, bagger, closer, and conveyor.

After the test, all apples were inspected according to the USDA grade standards for bruising. The average results from the eight packing lines showed that the percentage of bruised apples averaged at 69% at sampling point A and 99% at point D. The bruise size ranged from 6.4 mm to 12.8 mm in diameter. At the last testing point E alone 95% of the apples were bruised, with the largest percentage of bruises in the 12.8 mm to 19.0 mm diameter range compared with other sampling points. The sources of damage at each sampling point were also identified and recorded. At point E the main problems were apple-to-apple contact on the bagger feed-rolls, apple-to-apple contact as apples dropped into bags, and excessive vertical drop height from the weighing tray to the bag. It was concluded that the bagging operation, on the average, caused more bruises than any other single operation.

2.7.2 Bruise damage in New Zealand apples

A survey of bruising was conducted on a number of orchards in 1989 (Banks, 1991) showed that there were two major sources of bruises greater than 12 mm in diameter. The first of these was the harvesting operation up to dumping into the field bin. These bruises could arise from a number of influences such as compression or 'finger' bruising, careless placement into the bag, or impacts during picker movement from one place to another. The second source of larger bruises was on the grader, between when fruit left the sorting table and arrived in the final size bins (Studman 1990).

In 1990, another survey was carried out to identify more closely where bruise damage on a fruit packing line was happening (Banks, 1991). The incidence and severity of bruising at four points on graders on 11 packing lines were examined using Splendour apples. The four sites were identified as being more likely to cause bruising. As shown in Figure 2.3 point 1 was the fall from sorting table to singulator; point 2 was the passage of fruit beneath the transfer wheel from the singulator to the cup race; point 3 was the first drop onto a chute following release from the cup race; point 4 comprised the passage of fruit all the way from the cup race until it came to rest in a final size bin or tray.

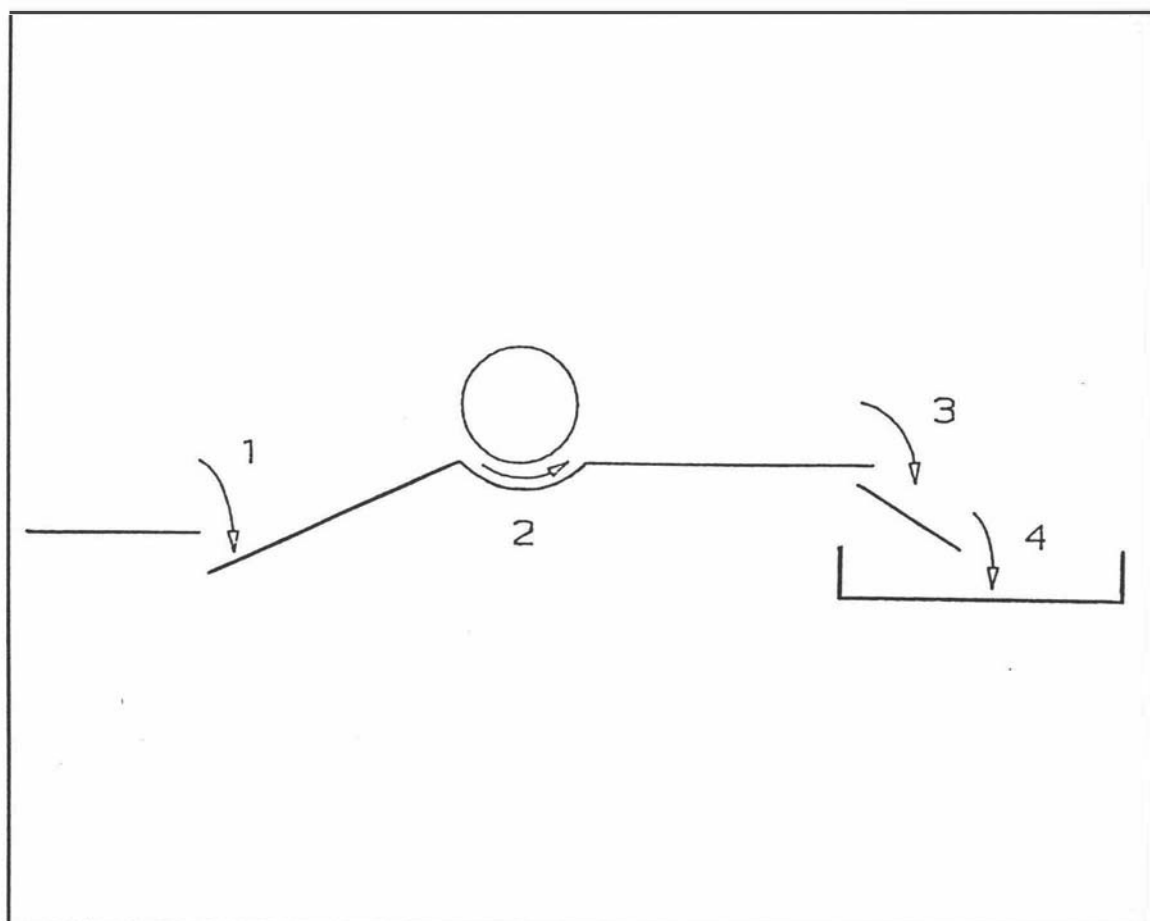

Figure 2.3 Problem points on New Zealand packing line

Splendour apples were harvested and placed into Friday trays directly by hand to

avoid pre-bruising. The fruit were stored in a commercial coolstore until required. During the test, each apple was placed into the flow of fruit before a testing point and removed from the flow after the testing point. The procedure was repeated four times to reduce the errors inherent in the random nature of the occurrence of impacts. Control fruit were also used to allow for handling errors.

It was found that the most serious bruising on apples occurred at points 2 and 4. Fruit-to-fruit impacts were the principle source of damage at point 4. This was found to be a problem on most graders.

2.7.3 Discussion

Existing American apple packing lines have been identified as having the highest potential for inflicting bruise damage to apples when compared with other postharvest related operations (Guyer et al., 1990). In order of importance, the problem points on packing lines were height differentials between components, fruit control under the transfer wheel, lack of absorption of impact energy with cushioning, and finally fruit-to-fruit impacts in area where the fruit has a high velocity. In New Zealand also, grading and packing equipment has been identified as a major cause of bruising.

reduction

[With the export-oriented marketing of New Zealand fresh fruit, great care must be taken in designing new packing machines or maintaining old fruit packing lines. As a general rule drop heights of apples between the packing line components should be reduced as much as possible, and all possible impact points should be well-padded.] From surveys of typical New Zealand grading equipment, it is clear that drop heights up to 40 cm occur, but damage during a large drop was less than might have been expected because of good padding. More importantly, the drop

points 1-3 in Figure 2.3 can be adjusted to reduce bruising. In contrast, small drops onto hard surfaces such as conveying rollers were hard to avoid. However bruising problems were not usually expected with such small drops. On the other hand, apple to apple impacts at point 4 caused bruising which was not easily overcome during bulk handling procedures. [Bruises produced by apple-to-apple impacts could also exceed the commercial standard of unacceptable bruise size. [Gaston and Levin (1951) reported that small bruises could make the apples less attractive than they would otherwise be. Since apple sales depend to a considerable extent on appearance (Opara et al., 1991), a moderate amount of bruising can be a serious problem.] Therefore, it was concluded that it was important to investigate bruise damage over a range of small drop heights onto hard surfaces and in apple-to-apple impacts.

3 INVESTIGATION OF BRUISING PHENOMENA

3.1 Introduction

Many studies have been carried out to investigate bruising damage under laboratory conditions (e.g. Siyami et al., 1988; Schoorl and Holt, 1980; Holt et al., 1981; Studman and Banks, 1990), and bruise damage by different components of a commercial packing line have also been studied by different researchers as described in Chapter 2. However, the extent of fruit bruising produced by a handling system at different temperatures and for different varieties of fruit has not been studied in detail. It is clear from the literature that bruise susceptibility of apples varies considerably depending on cultivar, harvesting and storage conditions (Klein, 1987; Hyde and Ingle, 1968). It is also clear that the situation is compounded by the absence of a standard bruise test which is consistent with industry experience (McLeod, 1992). Since bruising on grading equipment is a major concern to the industry, it was decided to assess bruising on a typical grader, and to use this as a standard with which to compare laboratory bruising measurements. This will provide a fundamental framework for evaluating the method of determining bruisability, leading to a more accurate method of quantifying bruise damage.

Bruise damage produced by a typical New Zealand grading machine (Treeways, two lane mechanical, as shown in Figure 3.1) is analyzed in this Chapter. This method was also used in the work described in the following Chapters as a standard method for producing fruit damage which was assumed to relate to practical bruising levels in the fruit industry in New Zealand.



Figure 3.1 Treeways two lane mechanical grading machine used for studying bruise damage

3.2 Materials and methods

Commercially picked Gala, Fuji, Braeburn, and Granny Smith were selected from field bins in the Hawke's Bay region at their respective harvest times. The fruit selected were placed into 88 count Friday trays in standard apple cartons, and transported to Massey University for studies.

A 2 lane Treeways grader with rotating final size bins, located at the Fruit Crops Unit of Massey University (Figure 3.1), was adjusted to drop all sizes of fruit into the same final size bin. During the tests, fruit were carefully placed by hand onto the sorting table in two pairs of lines, each pair close to an edge of the sorting table (as shown in Figure 3.2), so that each pair of lines fed into one cup lane of the two lane grader. After all the fruit had passed through the grader the machine was

stopped, and the procedure was repeated a total of four times on each fruit sample.

The fruit was then placed into an apple carton without Friday trays and transported by car to the Agricultural Engineering Department for assessment.

After 24 hours, apples were taken out one by one from the carton without any preference and inspected for bruising by an individual assessor who had no knowledge of the experimental design. The observations were made in a specially designed assessment room in which the lighting levels were set according to New Zealand Apple and Pear Marketing Board guidelines (Nicholas, 1992). Any visible bruise was noted. The major and minor diameters were measured. The bruise was classified as a discolouration, softening, indentation, or any combination of the three, and the bruise position on the apple was located into three equal width zones on the apple. These were top, cheek, and bottom (Figure 3.3), defined by dividing the height into three (this gives three equal surface areas if the apple was exactly spherical). Since Gala have a distinct blush side (more red), the location of bruises on blush or green side was also recorded. Bruises were detected and measured without removing the skin of the apple.



Figure 3.2 Fruit were placed onto sorting table of the grader

3.2.1 Temperature effects on bruising of Gala

One hundred Gala apples were randomly selected from cartons brought back from the Hawke's Bay orchard within 24 hours of harvest. The fruit were run through the grader four times at room temperature and then placed into an apple carton. The rest of the sample was put into a commercial cool-store at 0.5 °C for further use.

After 7 days, a second one hundred apples were taken out of the cool-store and run through the grader four times immediately (the grader was just outside the cool-store). The temperature of the fruit was assumed to be the same as in the cool-store. After 14 days, a further one hundred fruit were taken out of the cool-store and allowed to reach room temperature before the test. The procedure was then repeated. The handling procedure of the tests was kept as consistent as possible, so that the impact conditions were the same except the temperatures of the fruit tested. In addition to the test fruit, a sample of 20 fruit was treated in the same way as the sample, except that these were not passed over the grader.

During bruise evaluation of Gala apples, the side of each fruit (green or red) on which the bruise occurred was also recorded.

3.2.2 Cultivar differences in bruising

During their harvest period, freshly picked Fuji, Braeburn, and Granny Smith apples were also run through the same grader as described above. They were collected from different orchards and tested within 12 hours of harvest.

3.2.3 Assessor effects

Independent assessors were employed to record bruising to avoid possible observer bias. Unfortunately, owing to staffing problems, the assessment of bruising for fruit maturity and different varieties were carried out by different assessors to those who conducted the measurements on Gala.

3.3 Results

3.3.1 Type of bruises

Table 3.1 shows the percentage of bruises classified as discolouration, softening, or indentation produced by the grader for the three different treatments of Gala and the freshly picked Granny Smith, Fuji, and Braeburn apples.

For Gala apples nearly all bruises (92.1% - 96.1%) were deformed in the bruised region. In contrast, a large percentage of bruises was recorded only as a discolouration in Granny Smith and Braeburn apples.

| | | Number of bruises | Discolouration | Softening | Indentation |
|--------------|--------|-------------------|----------------|-----------|-------------|
| Gala | Fresh | 344 | 82.3 % | 79.1 % | 93.0 % |
| | Cooled | 403 | 82.9 % | 84.6 % | 92.1 % |
| | Warmed | 379 | 63.5 % | 89.0 % | 96.1 % |
| Granny Smith | | 384 | 93.8 % | 62.4 % | 15.0 % |
| Braeburn | | 60 | 95.6 % | 64.4 % | 27.4 % |
| Fuji | | 88 | 69.4 % | 68.5 % | 16.2 % |

3.3.2 Bruise distribution on apple

The experiment showed that when fruit passed through a grading operation, a large percentage (54.1% - 59.0%) of bruises were observed in the cheek region representing one-third of the surface area of Gala apples (Figures 3.3 - 3.5).

From Figures 3.3-3.5, it can be seen that the distribution of bruise over the fruit surface for different treatments was not significantly different.

The number of visible bruises on green and red sides of fruit is listed in Table 3.2. On average 63.3% of visible bruises occurred on the green side of the fruit and 36.7% on the red side of Gala apples.

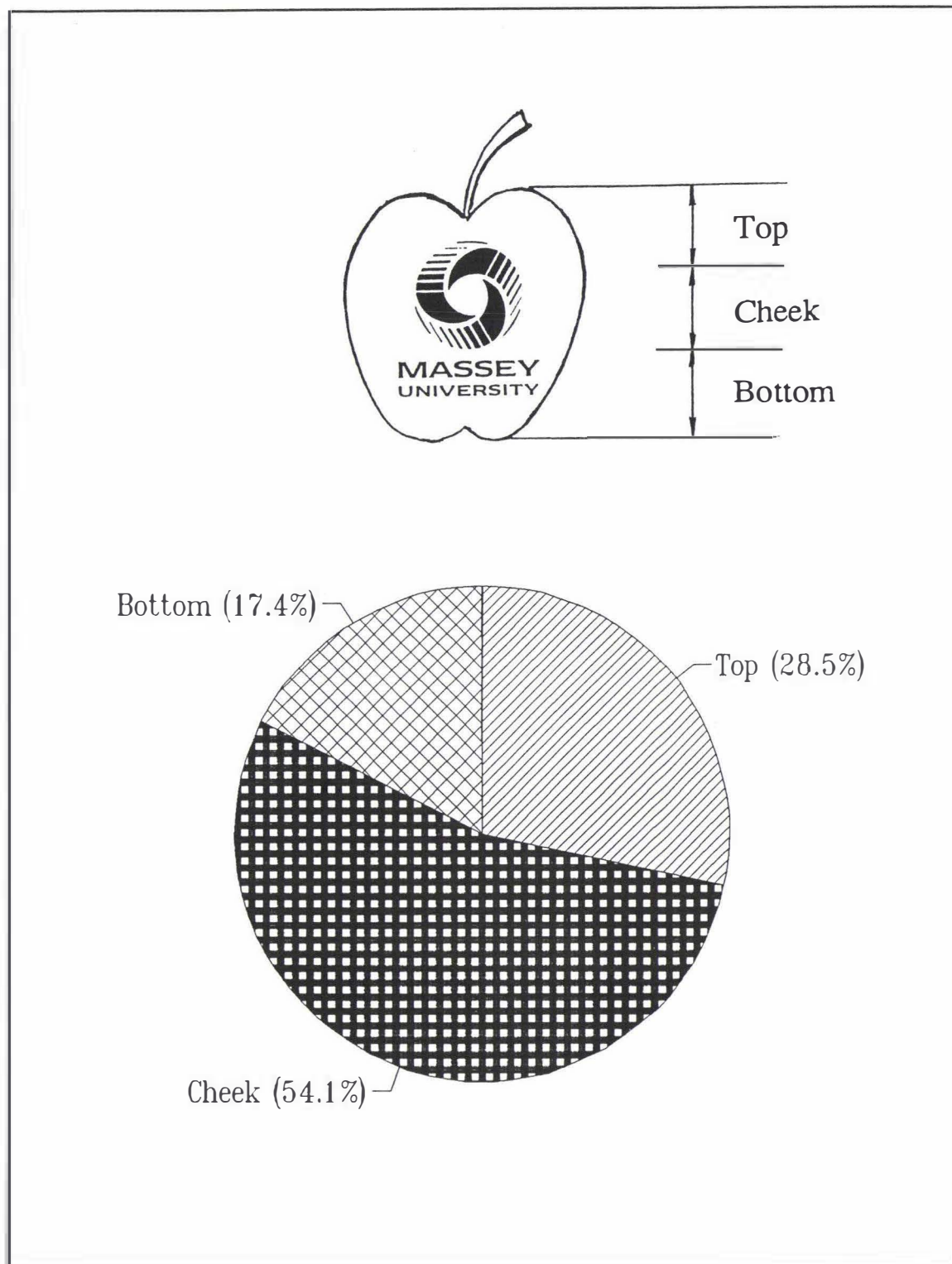

Figure 3.3

Percentage of bruises observed from different parts of fresh Gala apples

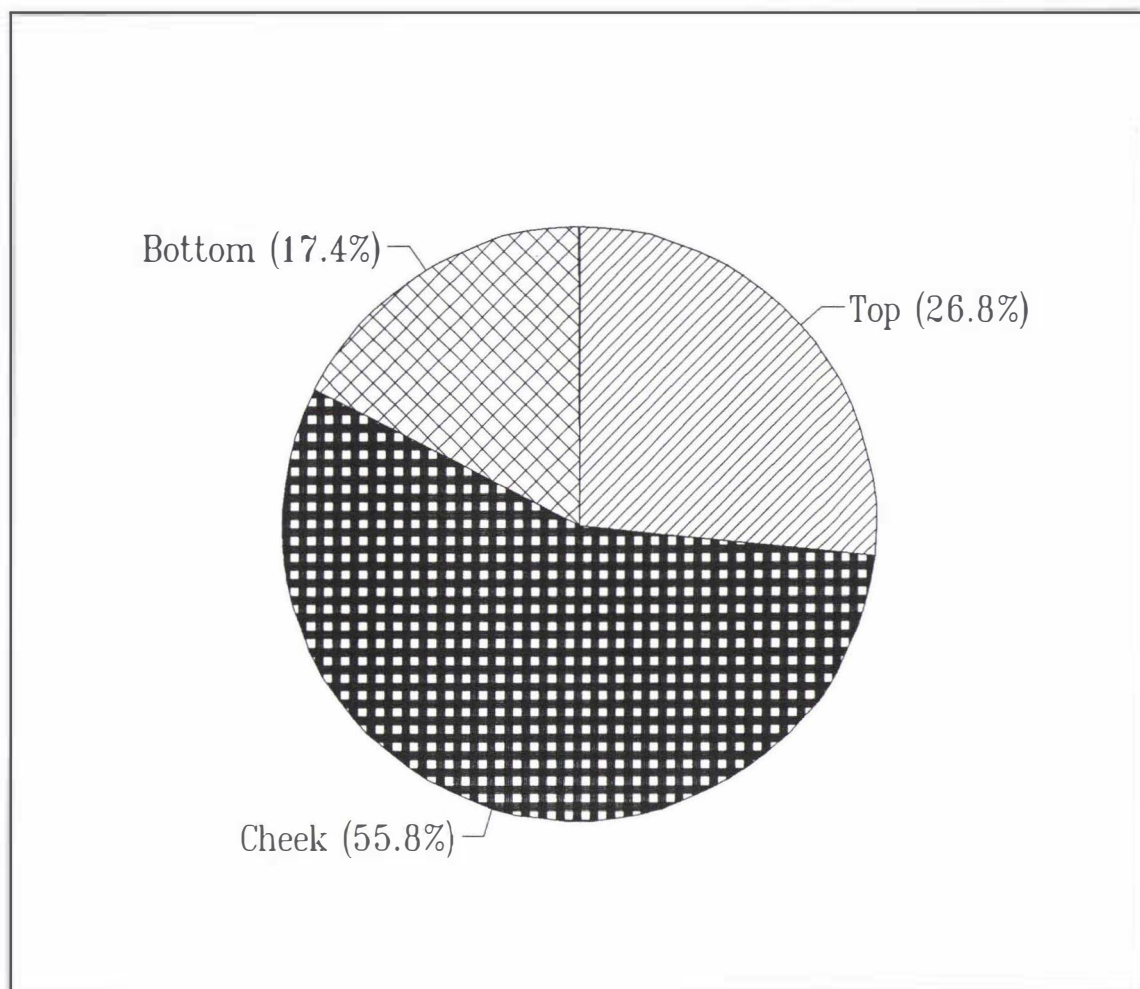

Figure 3.4 The percentage of bruises observed from different parts of cooled Gala apples

Table 3.2 Percentage of bruises recorded on different side of Gala apples at different treatments.

| Gala apples | fresh | cold | warmed |
|-------------|--------|-------|--------|
| Green | 62.8 % | 62.8% | 64.3% |
| Red | 37.2% | 37.2% | 35.7% |

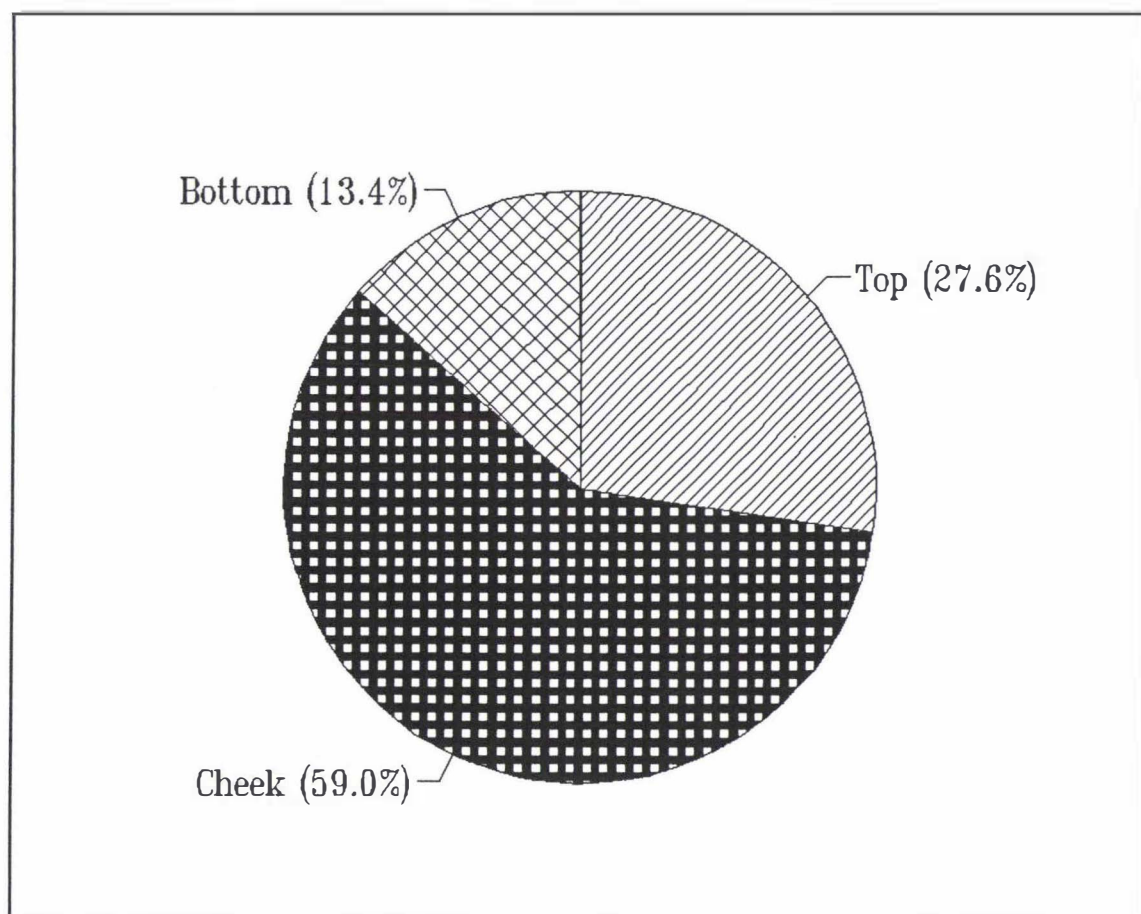

Figure 3.5 The percentage of bruises observed from different parts of warmed Gala apples

3.3.3 Frequency distribution of bruise sizes

Figure 3.6 shows a frequency distribution of apple bruises found after grading in the 3 trials on Gala. The number of bruises for fresh and warmed Gala fruit reached a peak value of about 0.65 cm^2 , and then decreased sharply. For cold fruit the peak was at 0.45 cm^2 . Very few bruises above 2 cm^2 were observed by the assessor. The total number of any visible bruises without skin removal were shown in Figure 3.7.

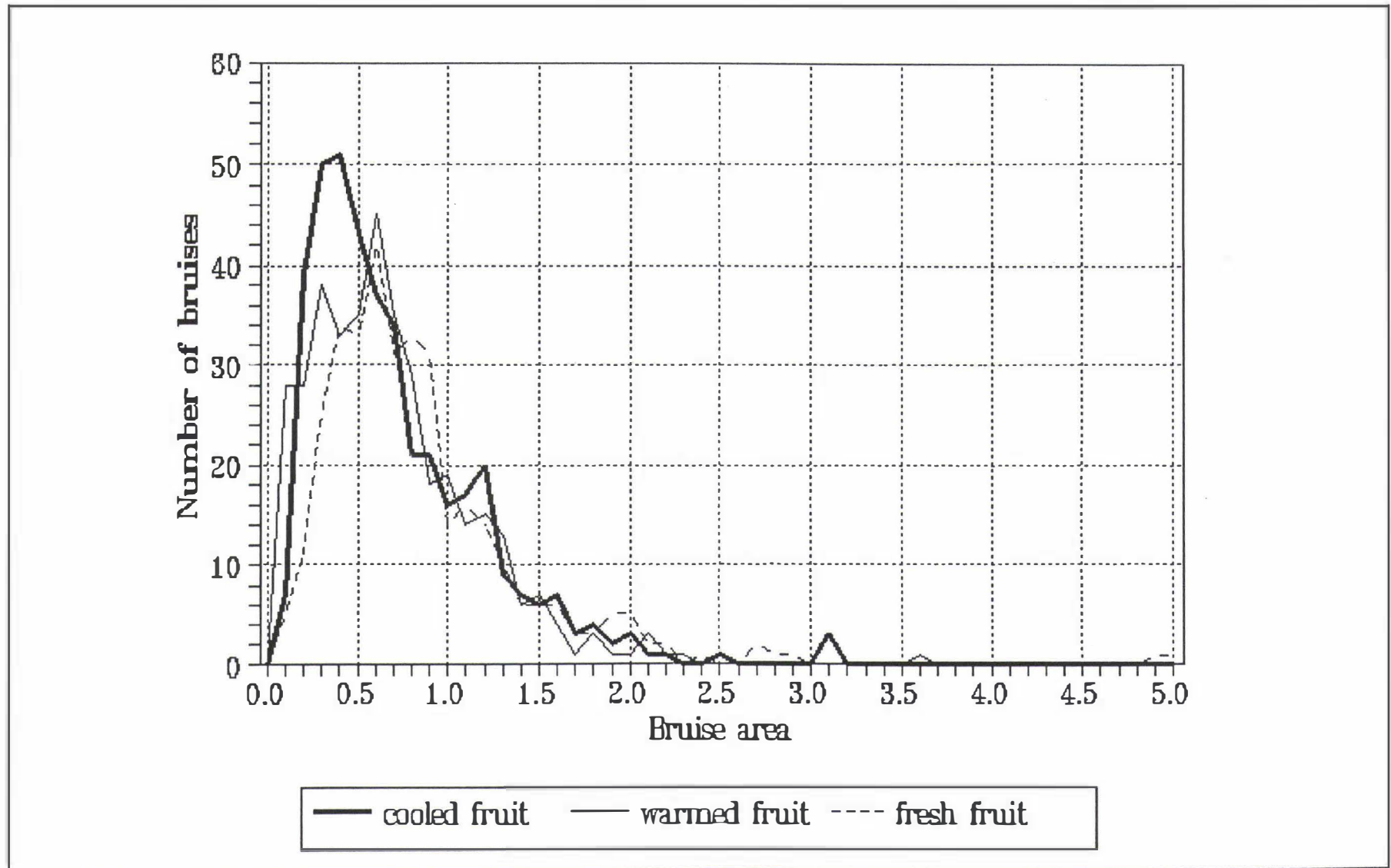

Figure 3.6 Frequency distribution of bruise areas (cm²) produced by Treeways fruit grader

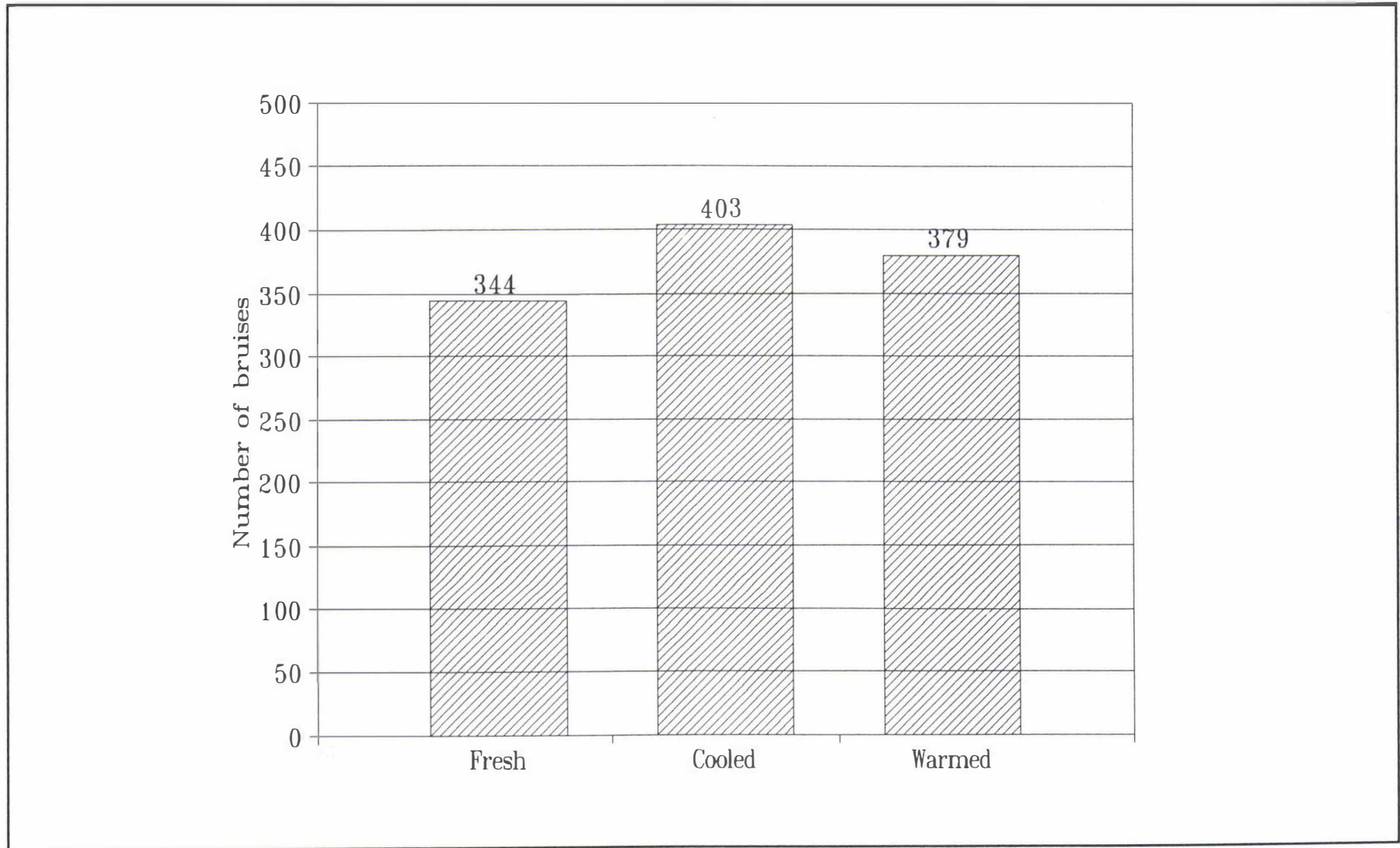

Figure 3.7 The total number of visible bruises without skin removal on fresh, cooled ,and warmed Gala apples picked commercially based on background colour

3.3.4 Discussion

According to New Zealand Apple and Pear Marketing Board standards for background colour of Gala exported, there should be two-thirds of red colour on each apple. The actual area of red colour on fruit should therefore be twice as great as the area of green colour. Although the experimental population of apples may have varied slightly from the export standard, it can be seen that bruises on the green side of fruit were more visible or more frequent.

The distribution of bruise area and the total number of bruises visible for three different treatments of Gala apples is illustrated in Figures 3.6 and 3.7. It can be seen that in the 3 different trials, in the range of bruise areas from 0 to 1 cm², the number of bruises were very different, while above 1 cm² there were almost the same numbers of bruises (Figure 3.6). Thus, there were more small bruises on cooled fruit than on fresh fruit, and when the cooled fruit reach room temperature, the number of small bruises decreased again. It should be noted that this experiment was designed for altering bruise susceptibility, and the differences may result from some effects of water loss or ripening rather than a temperature effect alone. It is likely that fruit with more small bruises would give the impression that the fruit were more susceptible to bruising. This is quite reasonable since, according to the New Zealand Apple and Pear Marketing Board's standards for export, any apple with an accumulated bruise area exceeding 1 cm² should be rejected. However the data also showed that all three samples had a similar number of bruises above 1 cm² in area. This implies that in an impact test if the impact energy levels used produced more than 1 cm² of bruise area, the bruise study may not detect any temperature effect in Gala. This may account for some of the differences between practical experience and laboratory measurements of bruising (Klein, 1987).

3.3.5 Human effects on assessment of bruising

[Assessment of apple bruising without skin removal can be a difficult and subjective task for researchers and quality inspectors, especially for bruises detected by softening, where the boundary of the bruise region may not be clearly defined. In such cases personal judgement is needed. For some varieties of apples with a dark colour, the bruised regions with discolouration were hardly visible.] As described in Section 3.3.2 there were only 37.2% bruises observed from the red colour side of Gala which covered two-thirds of the total surface area. [However for Granny Smith, most of the bruises were visible because of the clear discolouration of damaged regions (Section 3.3.1).]

[Assessing apple bruising where detailed measurement is involved is hard work for the eyes and a time consuming process.] It took about six to seven hours continuously for 100 Gala apples to be assessed. The rate of observation could change from morning to afternoon, especially for an impatient person.

The experimental results obtained by three different individual assessors, one male (assessor 1) and two female (assessors 2 and 3) of different ages, were therefore analyzed.

The number of bruises on every five Granny Smith apples was recorded according to the time of assessment from morning to afternoon. Figures 3.9 and 3.10 and show the number of bruises observed by assessor 2 and assessor 3 on the same day and on the same one hundred Granny Smith apples. In general the number of bruises increased from the beginning and decreased until morning tea break, then increased and slowed down until lunch time. In the afternoon, the number of bruises observed were relatively stable. From these two figures it can be seen that the total numbers of bruises observed by the two assessors on the same hundred

apples were different. Figure 3.10 shows the result obtained by assessor 3 on different samples of Granny Smith apples. The number of bruises on every five apples decreased almost consistently until a break. After each break it increased sharply. By comparison, a second sample of Granny Smith apples assessed by assessor 1 in two days were analyzed (Figure 3.11), and the number of bruises observed on the second morning increased as on the first morning.

The bruise assessment appeared to be affected by the individuals. For best results, the whole procedure and time of assessment should be kept as consistent as possible.

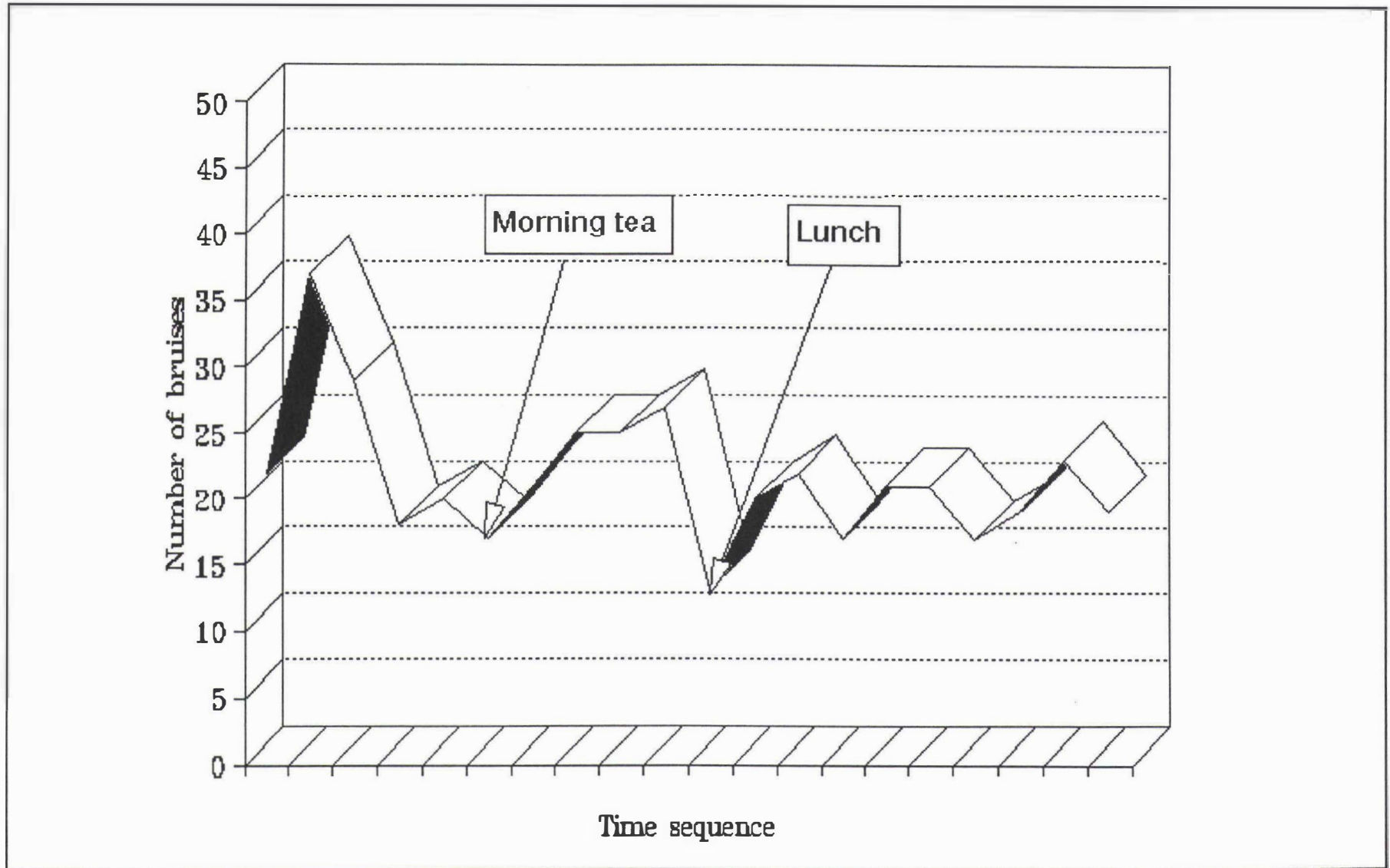

Figure 3.8 The number of bruises on every five Granny Smith apples observed on time sequence by assessor 1

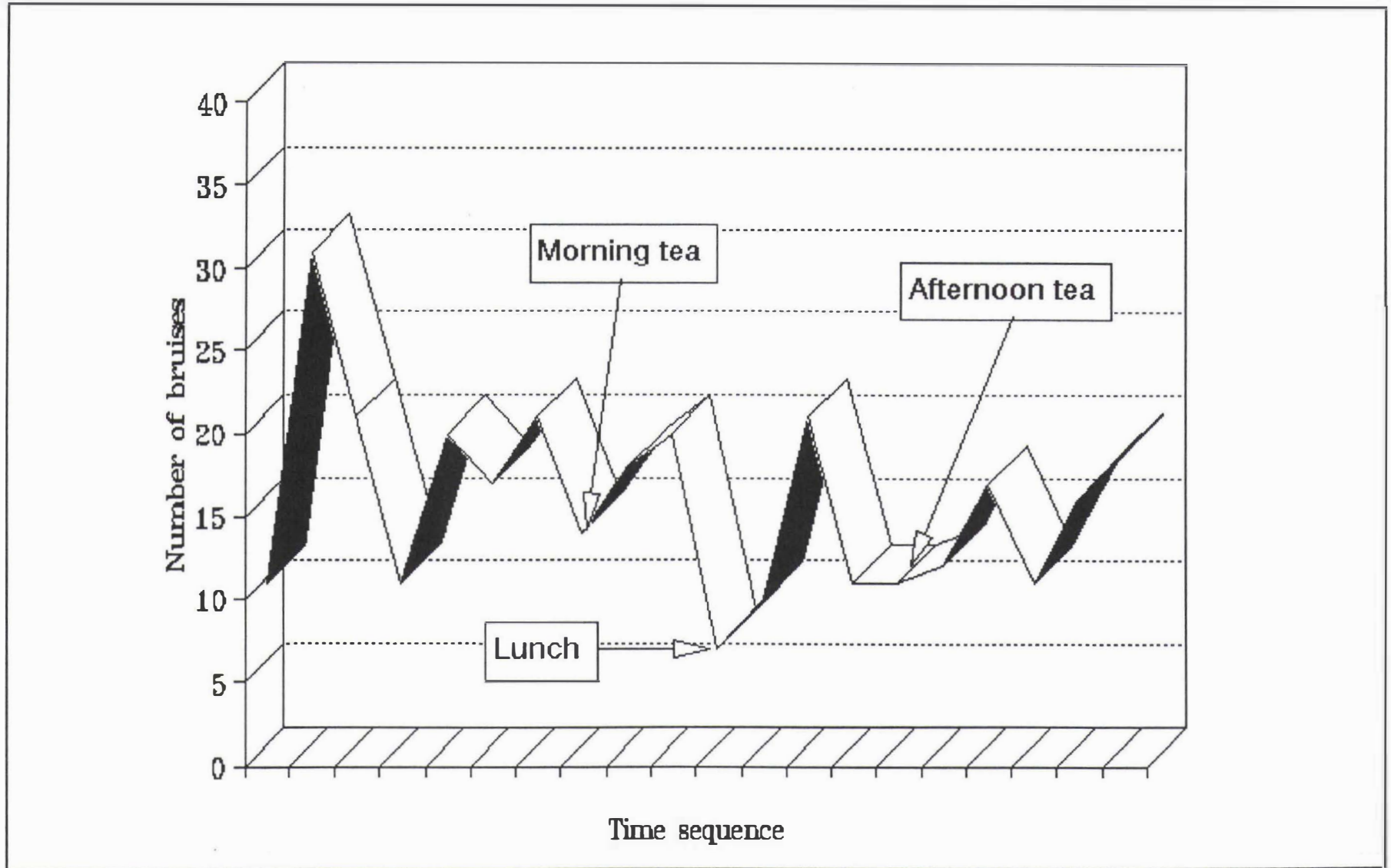

Figure 3.9 The number of bruises on every five Granny Smith apples observed by assessor 2 on time sequence

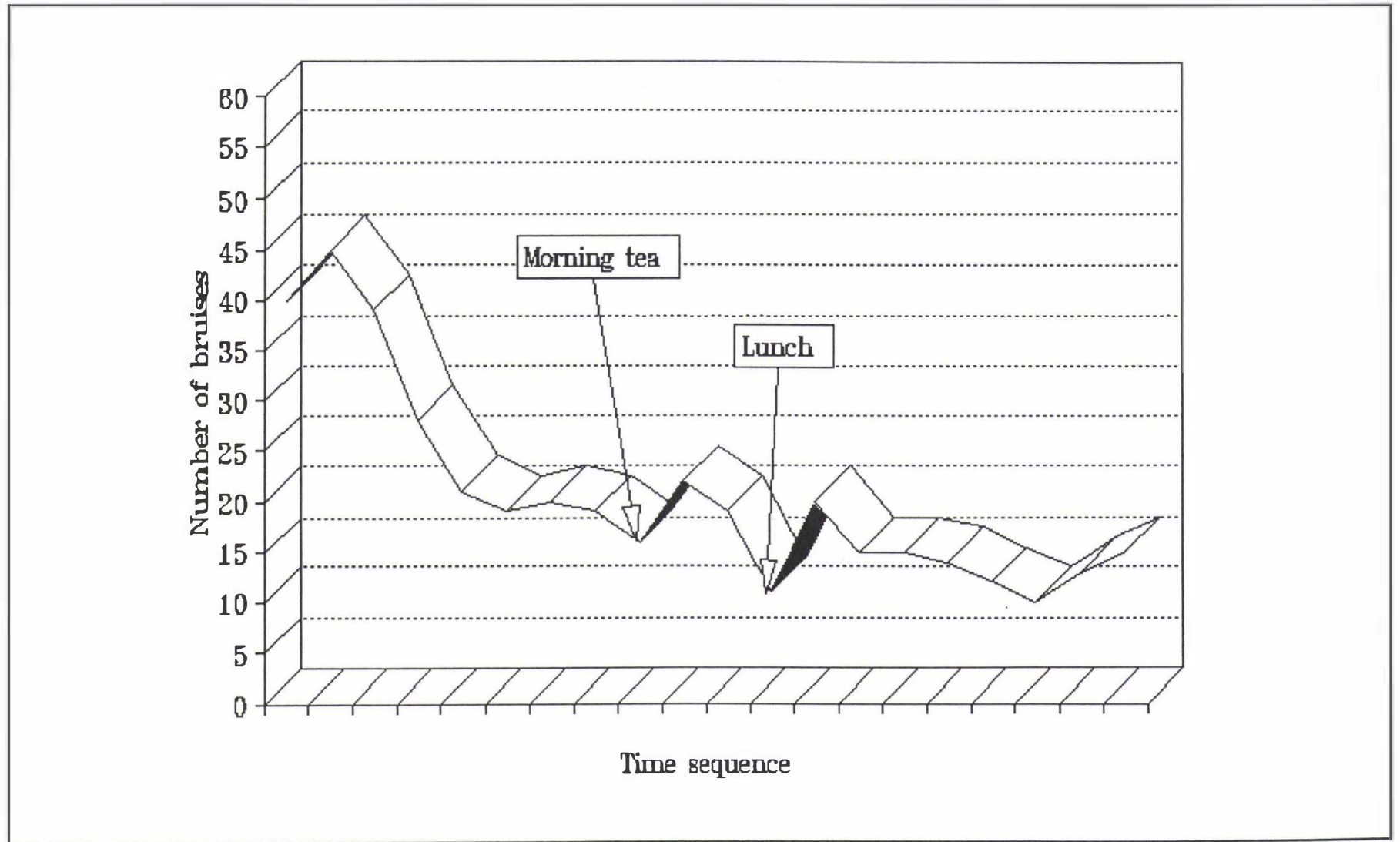

Figure 3.10 The number of bruises on every five Granny Smith apples observed by assessor 3 on time sequence from morning to afternoon

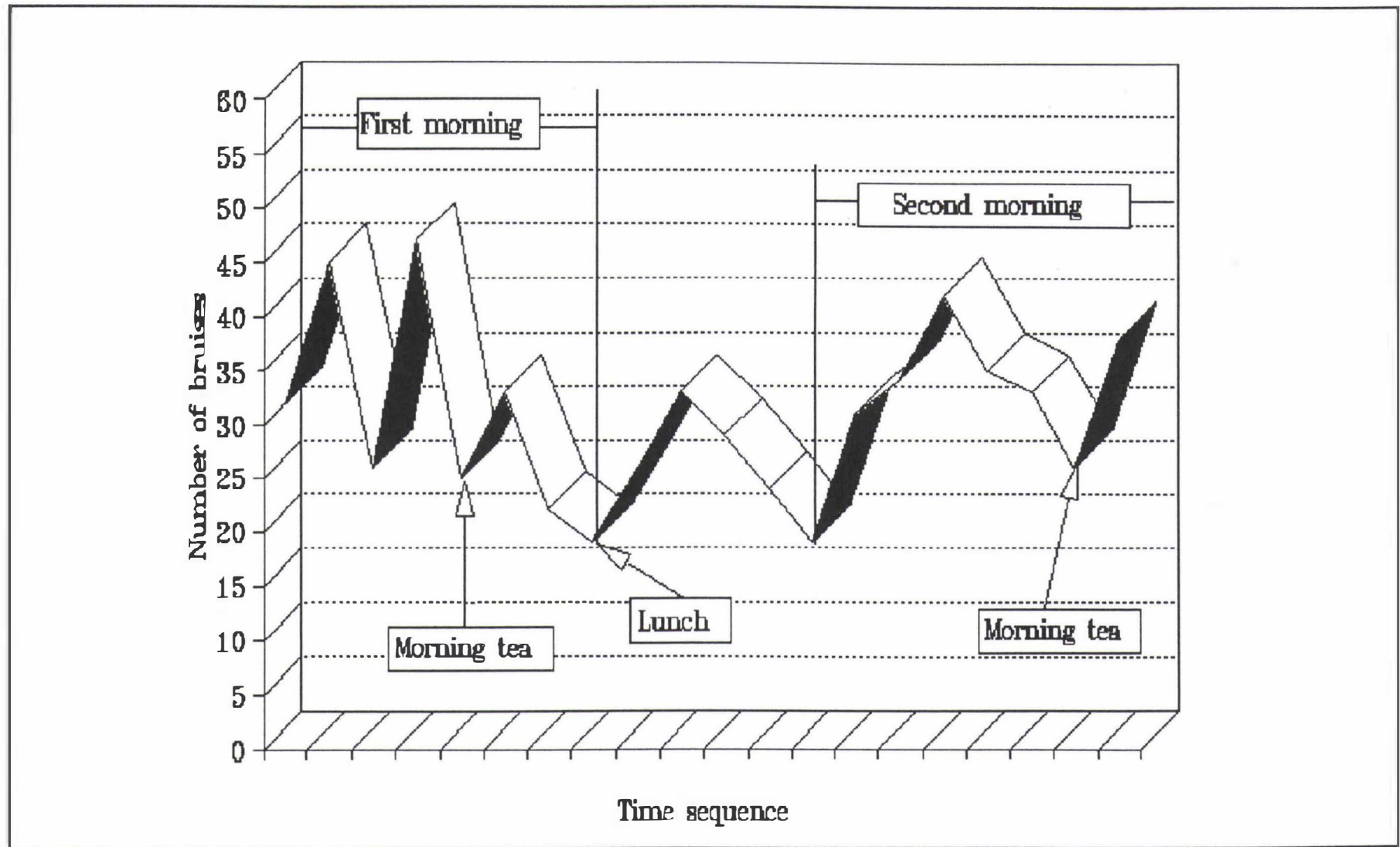

Figure 3.11 The number of bruises on every five fruit observed by assessor 1 in two days on one hundred Granny Smith apples under the same impact conditions

3.4 Conclusions

Apple bruises produced by the mechanical grader were more visible or more frequent on the green side of fruit compared to the red side and more in the cheek areas compared to the top and bottom areas. A large percentage of bruises were under 1 cm² in area and it was rare to have any bruises above 3 cm².

Gala apples at 0.5 C° were found to bruise more easily, but the total number of visible bruises seemed to be a more reliable indicator of bruise susceptibility of Gala apples under the tests of mechanical handling operations than the size of bruises above 1 cm² from a controlled impact. This was because when compared to apples at room temperature, the number of bruises above 1 cm² on cooled Gala apples (0.5 C°) remained unchanged while the number of bruises under 1 cm² increased.

4 USE OF AN INSTRUMENTED SPHERE

4.1 Introduction

The Instrumented Sphere (IS) developed at Michigan State University (Brown et al., 1990), records the impacts it experiences as it passes through a handling operation. The impacts are described in terms of a combination of acceleration and velocity change. The output of the IS must be interpreted with care, and it is therefore necessary to understand the procedures for collecting sample runs, storage of information, and calibration, especially for researchers who want to develop the relationship between output and bruising levels. In this chapter, the interpretation of IS hardware, software, and calibration is described. The technique for using it on commercial packing lines to gain accurate information is also discussed.

4.2 Description of Instrumented Sphere

The 90 mm diameter self-contained IS used in this work was a stand alone impact recording device designed to record the impacts it experienced while handled with like-sized commodities (apples, pears, peaches, oranges, Figure 4.1). The IS was developed by the USDA group at Michigan State University, and is sold commercially by Techmark Inc., Michigan. The model described in this study was the IS100, which was the first commercial version of the Instrumented Sphere. The Sphere is shown in Figure 4.1. The upper figure shows the IS and its charging unit, while the lower figure shows the circuit board, accelerometer and connectors of a sphere which has been dismantled. It had 32k of memory, a 3 axis accelerometer, a microprocessor, and rechargeable batteries. The IS weighs approximately 0.33 kg and had a specific gravity of approximately 0.95. The circuit board was insulated

with a rigid foam, and cast in beeswax for structural hardness. External communication with the microprocessor was through a miniature 5-pin connector. This connector provided for bi-directional RS232 serial communication, battery recharging, system reset and system shutdown. Analysis of recorded vector accelerations above a preprogrammed threshold allowed estimates of impact levels.

Software provided by Techmark was written to unload stored data and to perform various processing tasks on the data. The outputs included X, Y, and Z accelerations and their time of occurrence for each impact. The resultant impact peak g's (vector sum), velocity change (area under the acceleration curve), and impact duration were printed in tabular format as shown in Figure 4.2.

Initially, the IS produced a set of data in a hexadecimal format according to preset operating parameters (Figure 4.3). The preset parameters included sampling frequency, threshold, length of leader and trailer and a message input by the operator. Data was initially saved into a file with an extension name of IS. This was an un-calibrated hexadecimal data file with preset parameters, message, time of occurrence, and the data collected by the accelerometers in three axes (X, Y, Z) through the duration of each impact.

During data collection, sample frequency determined the rate at which the impact data was sampled. Throughout this entire study, 3906 Hz was used; in other words, accelerometer readings were taken into the buffer every 0.256 ms. The CPU provided minimum threshold trigger level, which was preset by users before each test, and stored in the memory. The leader and trailer values determined the number of data points which were to be stored prior to and following the first and last measurements which exceeded the threshold (normally 9 or 10).

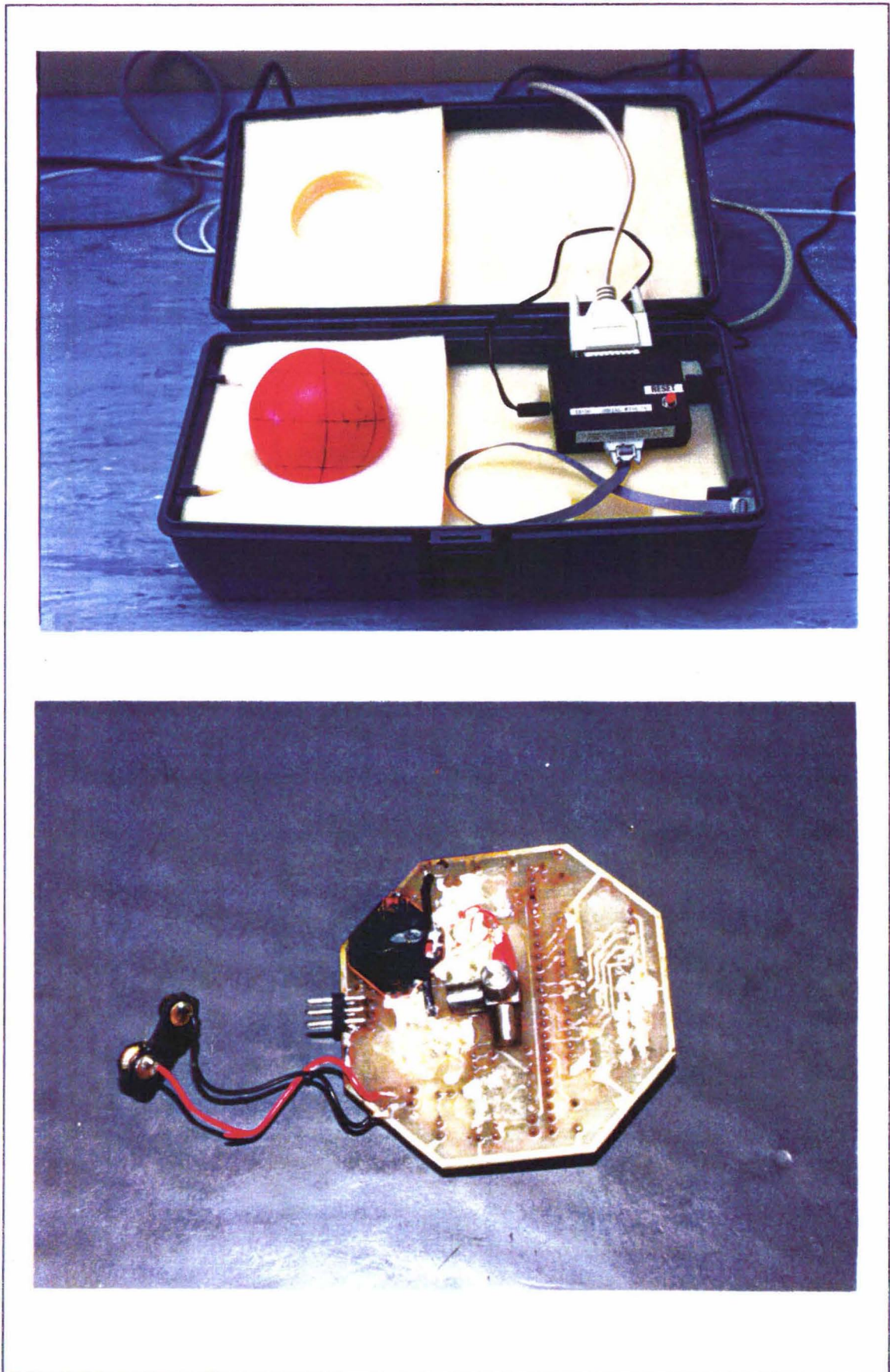

Figure 4.1

The Instrumented Sphere used in this study

| | |
|---------------------|-----------------------------|
| IS SERIAL NUMBER | 16 |
| DATA FILE NAME: | granny1.IS |
| SAMPLING FREQUENCY: | 3906.25 Hz |
| THRESHOLD COUNT: | 3 (11.805 g's) |
| LEADER LENGTH: | 5 |
| TRAILER LENGTH: | 5 |
| FILE SIZE: | 2261 BYTES |
| USER MESSAGE: | granny1 04-25-1991 10:55:47 |
| TERMINATION: | NORMAL |

GENERAL ANALYSIS FOR FILE granny1.IS

| IMPACT NUMBER # | TIME OF IMPACT (hr:min:sec) | IMPACT DURATION (ms) | MAXIMUM ACCEL'N (g's) | VELOCITY CHANGE (m/s) | USER COMMENTS |
|--------------------|--------------------------------|-------------------------|--------------------------|--------------------------|---------------|
| 1 | 10:56:56.703 | 5.1 | 17.4 | 0.60 | |
| 2 | 10:57:01.894 | 5.1 | 13.1 | 0.56 | |
| 3 | 10:57:05.667 | 5.6 | 13.1 | 0.62 | |
| 4 | 10:57:09.539 | 5.6 | 17.4 | 0.66 | |
| 5 | 10:57:13.031 | 5.4 | 17.4 | 0.62 | |

Figure 4.2 Typical output of the Instrumented Sphere

The acceleration of each sample point on X, Y, Z axes was calculated by using the calibration intercept (e.g. 128=0) and the slope from a calibration file. The slope of the calibration file was obtained from the regression of peak acceleration recorded by the IS and the reference acceleration of the drop table which is a standard testing table. The calibration file supplied with the Instrumented Sphere software is given in Appendix A. Axes were then vector summed by taking the square root of the sum of the squares of each acceleration vector component. In the cases of apple impacts there were about 30 readings. The maximum value of these was taken as the peak acceleration and the velocity change was taken as the sum of products of each value and the time interval (i.e. the area under the acceleration curve). The duration of an impact was calculated from the time interval multiplied by the total number of readings stored for each impact pulse.

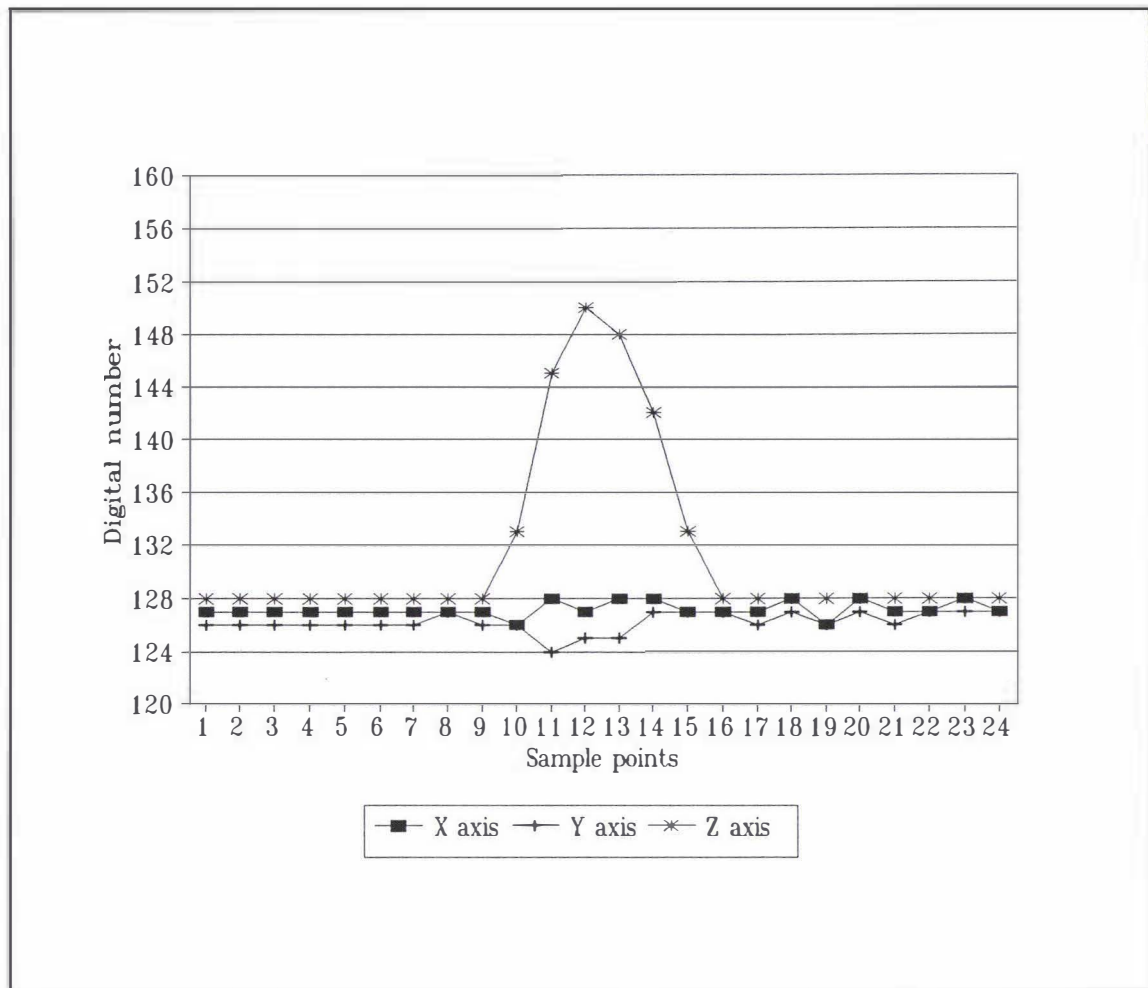

Figure 4.3 A typical un-calibrated pulse (integer format) recorded by the Instrumented Sphere during an impact against flat steel surface in direction of Z axis

The time of occurrence recorded was based on the time initialization from the host computer.

4.3 Determination of bruise threshold

In order to provide bruise threshold information which can be used accurately to predict the level of bruising in a handling system, the specific apple variety must be considered to identify the minimum impact condition necessary to initiate bruising. Initially one might expect that bruising would be corrected with peak acceleration only. While acceleration is a key factor, Siyami et al. (1988) and Schulte-Pason et al. (1990) showed that it was not sufficient. They found that both acceleration and velocity change were needed, particularly where impacts against padded surfaces were included. Accordingly Schulte-Pason et al. (1990) calculated the impact surface characterisation lines (velocity change vs peak g) for the six impact surfaces combined with the bruise threshold response lines for "McIntosh" apples (0 - 10%, 50%, and 100% bruise thresholds as in Figure 4.4). The surface response (flat) was found to be best determined by using a combination of the velocity change and peak g calculated for each pulse by many researchers. The calculated impact duration is often not a useful variable (Brown et al., 1990). This is because recorded impact duration was controlled directly by the impact shape and the length of the given leader and trailer. It should be noted that this method ignored impacts against other fruit. The approach will be re-examined in Chapters 5, 6, and 7.

4.4 Adjustment of IS calibration parameters

When the Instrumented Sphere was first received, it was found that the output varied significantly when dropped from same height onto a surface. It was decided to conduct a series of tests in order to understand the procedure used for analyzing the IS software and to check its repeatability.

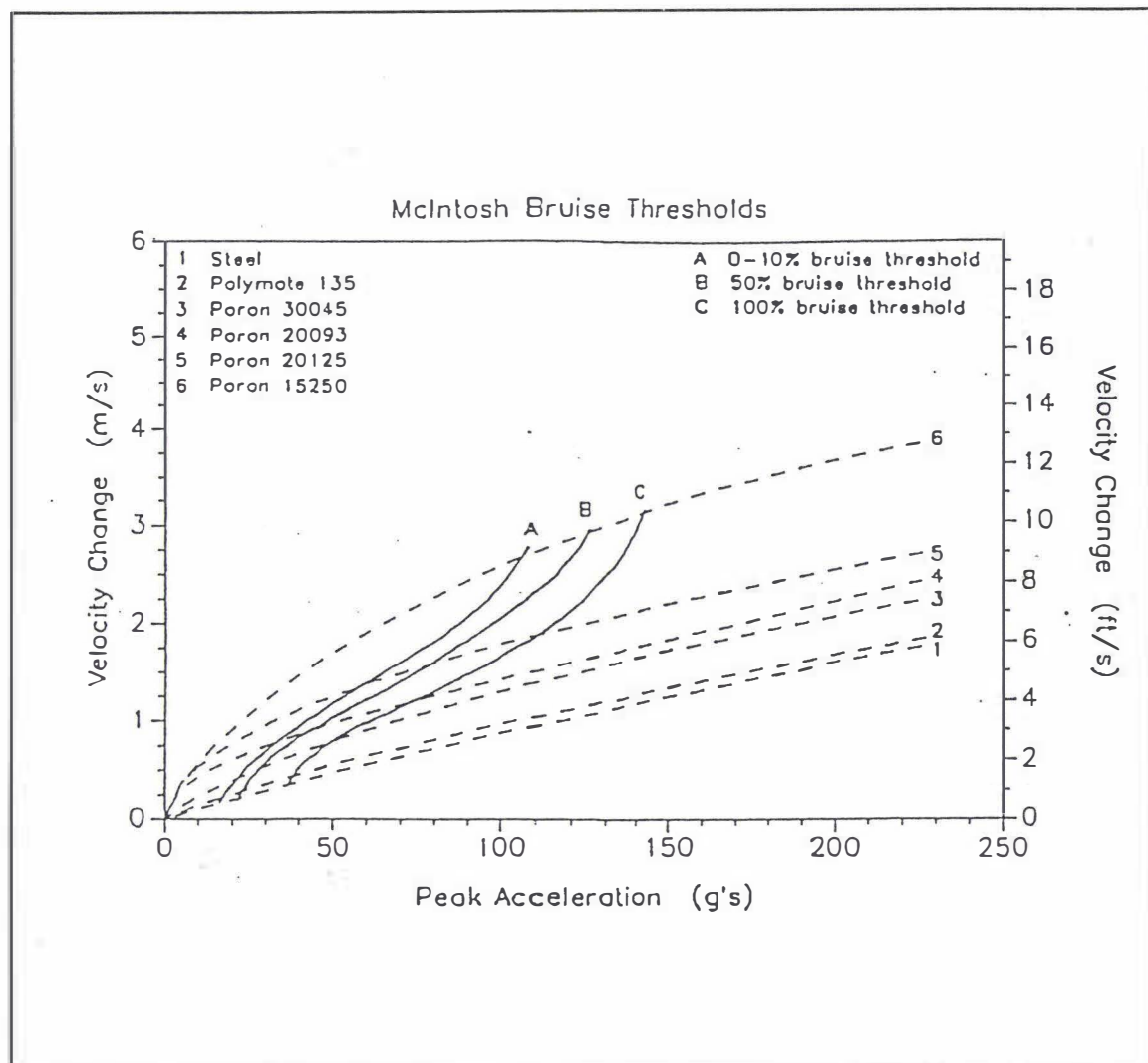

Figure 4.4 Apple bruising initiation threshold lines (0-10, 50, and 100% bruising) for velocity change versus peak acceleration compared to impact surface response lines created using a 89 mm diameter IS, (Schulte-Pason et al., 1990)

Before the tests, the axes of the IS were carefully identified from the user's manual and marked on the surface. The Instrumented Sphere was dropped from a series of heights onto a flat steel surface. Six impacts at each axis, three in a positive direction and three in a negative direction, were carried out for each drop height. There were 18 impacts for three axes for each drop height in total, and the average of six values for each axis was taken as the acceleration recorded by the accelerometer respectively. Theoretically the average acceleration recorded by three precalibrated accelerometers from the same drop height should be similar. The results of this test, however, showed that they were apparently different as

shown in Figure 4.5. The values of acceleration recorded by the X and Y axes were

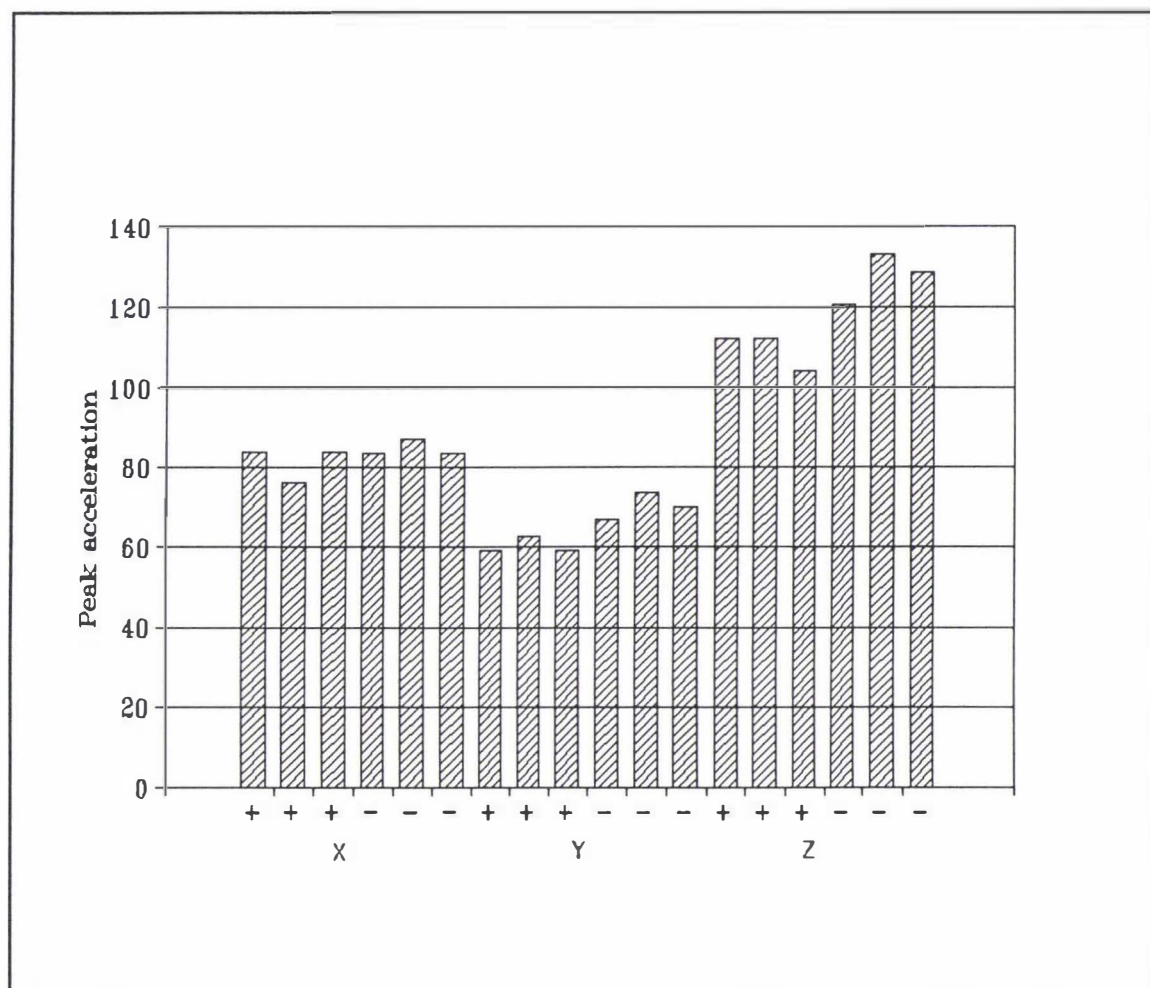

Figure 4.5 Peak acceleration (g) of the Instrumented Sphere recorded in three different directions

always lower than that recorded by the Z axis. This implied that the IS drop from the same height onto a different part of its surface would result in different values of peak acceleration, which was clearly unacceptable.

In order to find out what caused the uneven output, it was necessary to check the original output in the IS file. A computer programme (Appendix B) was written specially for this purpose by using turbo pascal to interpret the original hexadecimal output file of IS into an integer format as shown in Appendix C.

As shown in Figure 4.3, the velocity change was controlled mostly by the pulse shape, and only slightly by the area under the pulse tails. However the duration was directly controlled by the pulse shape and the length of leader and trailer. From the first 9 readings and the last 9 readings, it can be seen that the accelerometers at different axes recorded nothing until the tenth sample point, so that the integer values at this range could be used as intercept offsets (127, 126, 128) to adjust the calibration parameters in the calibration file.

Using the calibration file with the new intercept offsets, the results of experiments were reanalysed. The average acceleration from the three different accelerometers at a given drop height was taken as the standard acceleration to calculate the individual slope of the regression line for the plot of actual acceleration against the standard one. The individual slope was used to adjust the slope in the original calibration file. The same original IS output was reanalysed by using the new calibration file, and the results are showed in Figure 4.6. This modification clearly reduced the variability between the axes, although there was still some variation in the readings along the 3 axes. It was therefore decided to re-calibrate the IS.

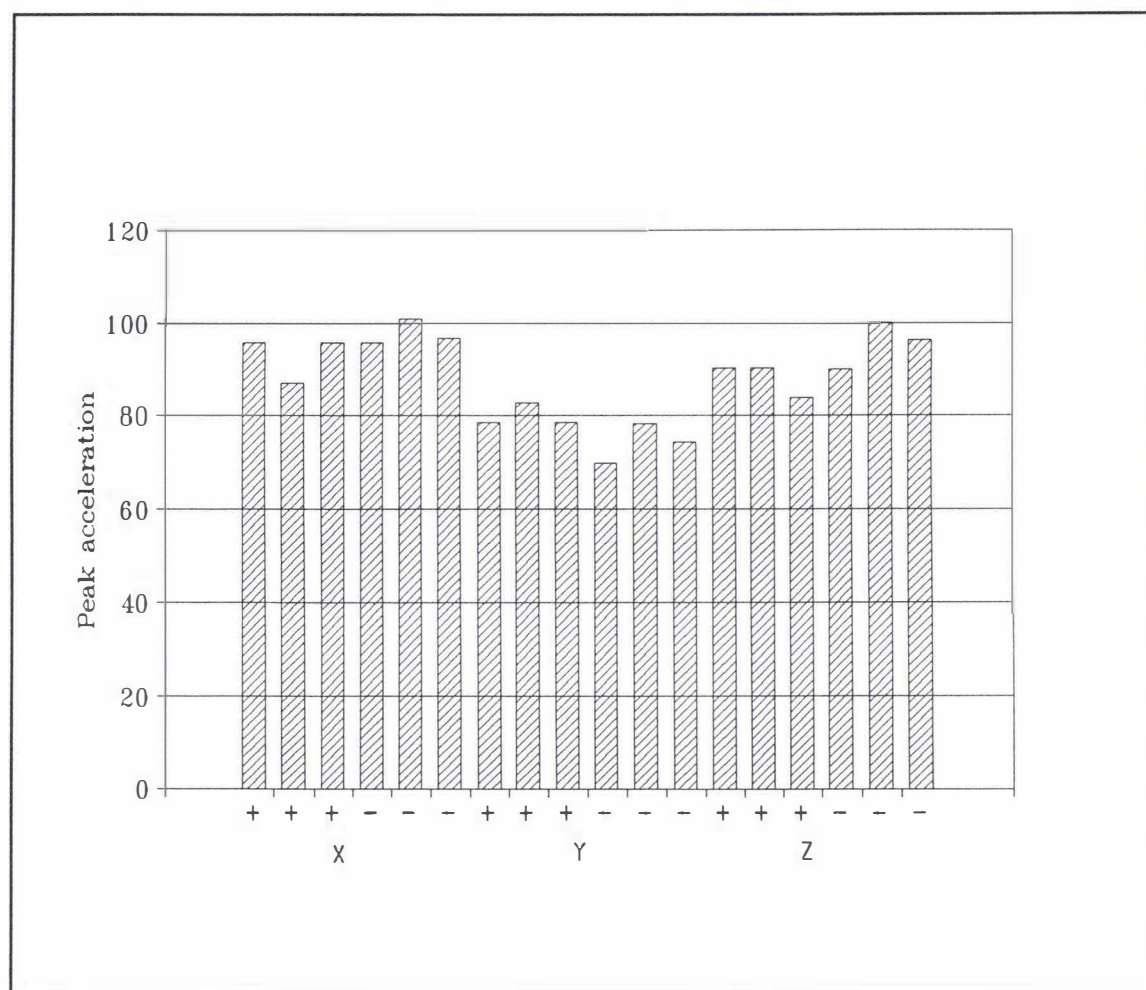

Figure 4.6 Peak accelerations (g) produced by the Instrumented Sphere with the new calibration file

4.5 Calibration of Instrumented Sphere

In order to confirm the accuracy of the calibration above, a simple device was designed and constructed in the Laboratory of the Department of Agricultural Engineering as shown in Figure 4.7. There was a piece of cushioning material between the base block of steel and the drop block of steel. The Instrumented Sphere was attached to the top of the block with pressure sensitive tape, and an accelerometer (PCB, Quartz Accelerometer, model 321A04) was attached onto the dropping block as close to the IS as possible. The impact block could be lifted and held by string in order to drop the block from two sides simultaneously to achieve a regular impact pulse. The accelerometer was connected to a 50 MHz Digital Storage Oscilloscope (model PM3335). Its data was transmitted to a computer through a RS-232 interface. The programming codes used are shown in Appendix D.

Data recorded by the computer were saved as a file in an integer format. There was one space between the numbers across the whole page and 701 values in each file. The data in separate files were analyzed and calibrated based on the specifications of the accelerometer (20 mv/g) and the voltage recorded by the oscilloscope. The real time interval of the oscilloscope was used to calculate the duration and velocity change of each impact, and then the results of analysis from separate files were put into one file in order to compare the different peak accelerations and velocity changes of different impacts. The whole procedure was analyzed by a program called 'Impulse' which was written in Turbo Pascal Language (See Appendix E).



Figure 4.7 Experimental device to calibrate Instrumented Sphere

During the analysis, it was found that the impact duration provided by the Instrumented Sphere was longer than that recorded by the Oscilloscope for the same impact as shown in Figure 4.8 and Figure 4.9. The duration recorded by the IS was directly controlled by the preset length of the leader and trailer, and was not the true duration of the impact, especially when an impact pulse had a short duration.

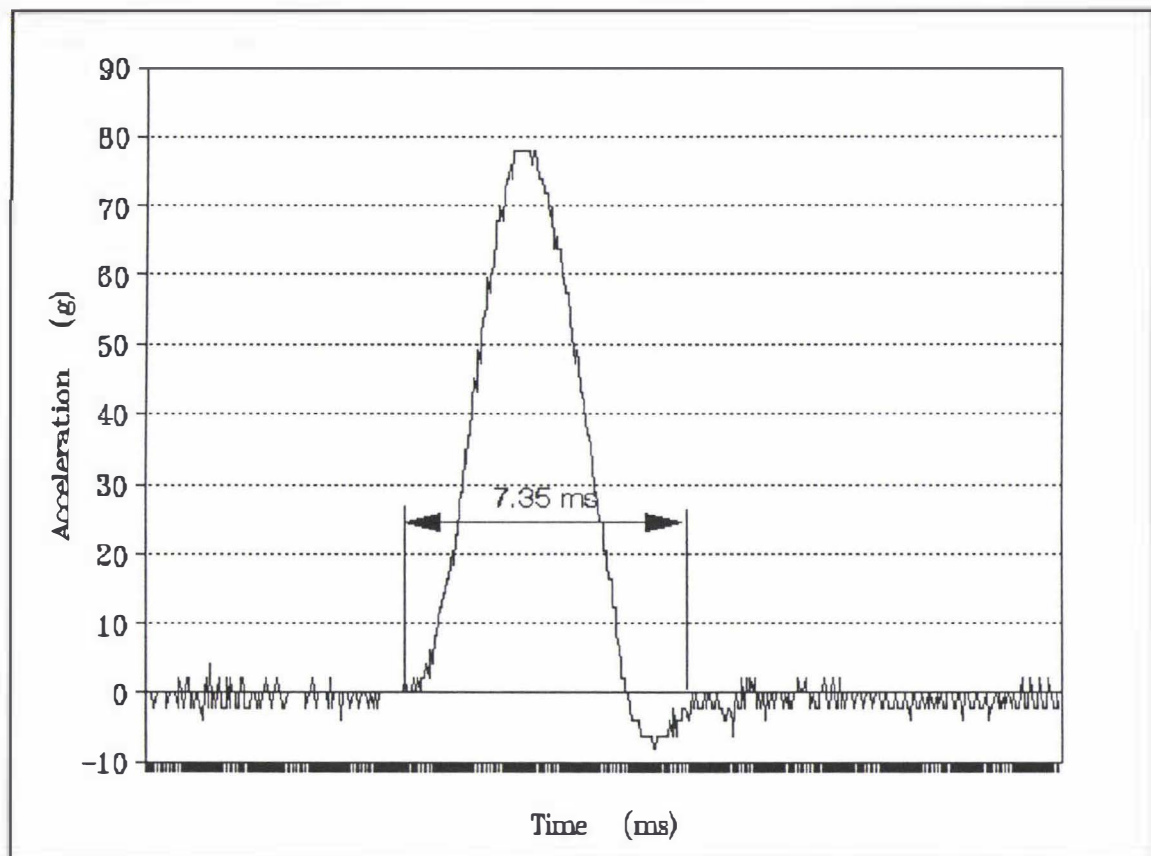

Figure 4.8 Impact pulse obtained by the Accelerometer and Oscilloscope

The Instrumented Sphere and accelerometer were dropped from 11 different heights. The acceleration recorded by the Oscilloscope was taken as the standard acceleration, and the IS outputs from the newly adjusted calibration file and the old calibration file were plotted against the standard one (Figure 4.10). The regression lines were as follows:

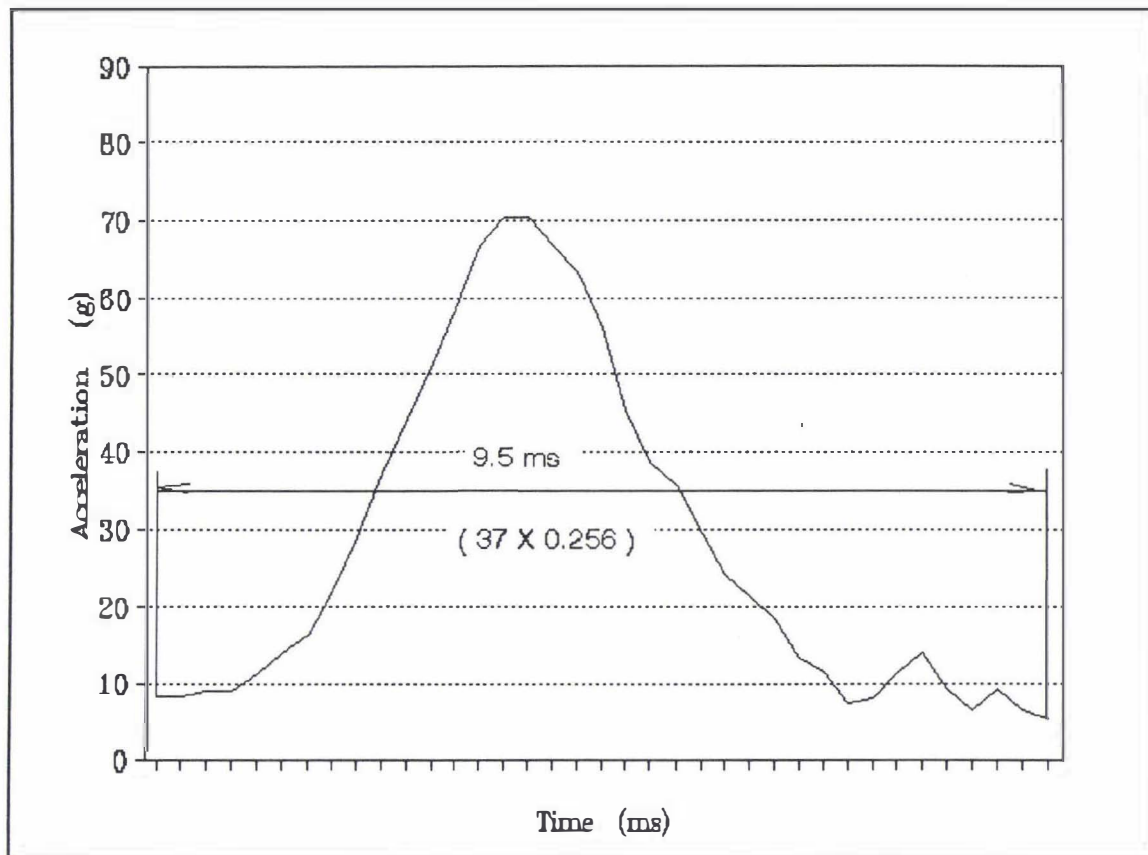

Figure 4.9 Impact pulse obtained by Instrumented Sphere

| | | |
|----------|-----------------------------|--------------|
| Adjusted | $A_{ais} = 1.00 A_r + 1.80$ | $R^2 = 0.99$ |
| Original | $A_{ois} = 0.86 A_r + 4.31$ | $R^2 = 0.99$ |

where A_{ais} is the peak acceleration recorded by IS using the adjusted calibration file, A_{ois} is the peak acceleration recorded by IS using the original calibration file and A_r is the acceleration obtained by the accelerometer. From the equations it can be seen that the adjusted acceleration was slightly different from the reference acceleration (1%), but the original calibration file gave 14% difference from the reference acceleration. This implied that the adjusted calibration file was much more accurate than the original file, and this new file was used subsequently.

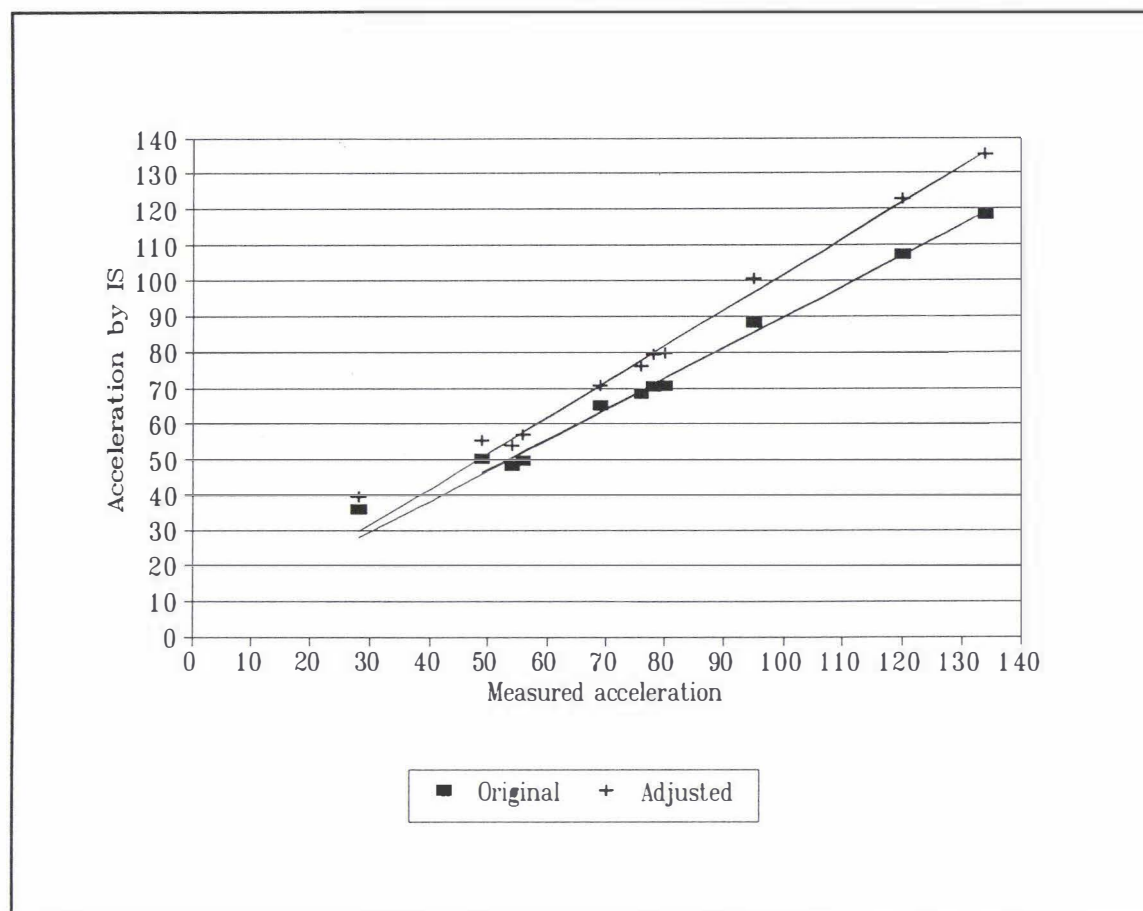

Figure 4.10 Relationship between peak acceleration recorded by IS both with adjusted and original calibration files and acceleration measured by using an accelerometer

4.6 Commercial packing line tests with Instrumented Sphere

Based on the new calibration file, in the 1991 season, six commercial packing lines in the Hawkes Bay region were tested using the IS to study the impacts produced by a fruit grader. The results generally showed a range of peak acceleration from 10 g to 130 g as shown in Figure 4.11 for a Treeways fruit grader. In order to identify impacts the passage of the IS through the packing system was recorded with a video camera as described by Bollen and Dela Rue (1990). Once the IS began acquiring data it was filmed as it was given an initial impact to serve as an exact timing mark. This enabled the video clock and the internal clock of the IS to be synchronised. When an impact was identified by the IS, the video was played back

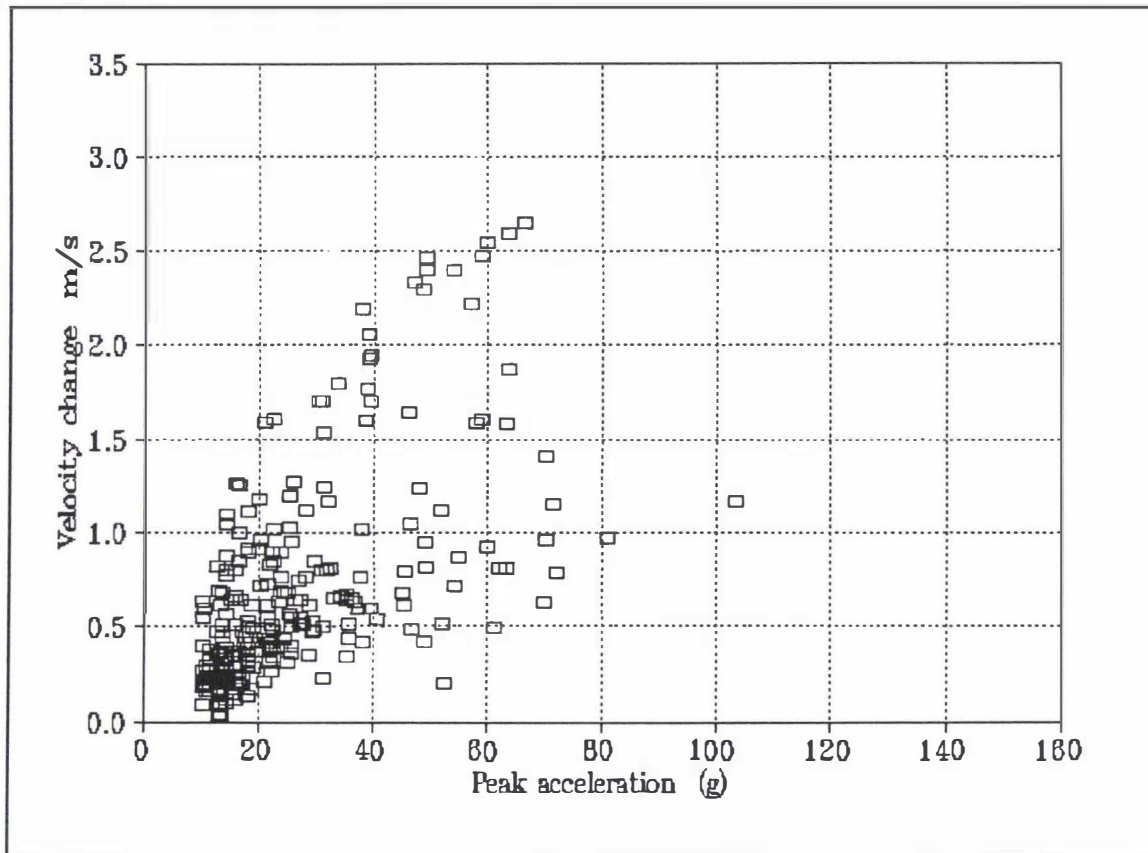

Figure 4.11 The impacts recorded by IS from a New Zealand typical fruit packing line

in slow motion. For example, in this way the impacts against fruit were identified and marked on the plot of IS output as shown in Figure 4.12 (points 1 to 5). This indicated that the IS recorded impacts up to 23 g's (with velocity change 1.3 m/s) against other fruit. Laboratory trials were therefore necessary to establish the level of bruising which such an impact would produce if the IS was replaced by another fruit. Fruit-to-fruit impacts must be included in the analysis of IS bruise threshold because of the importance of fruit-to-fruit impacts on a commercial handling system.

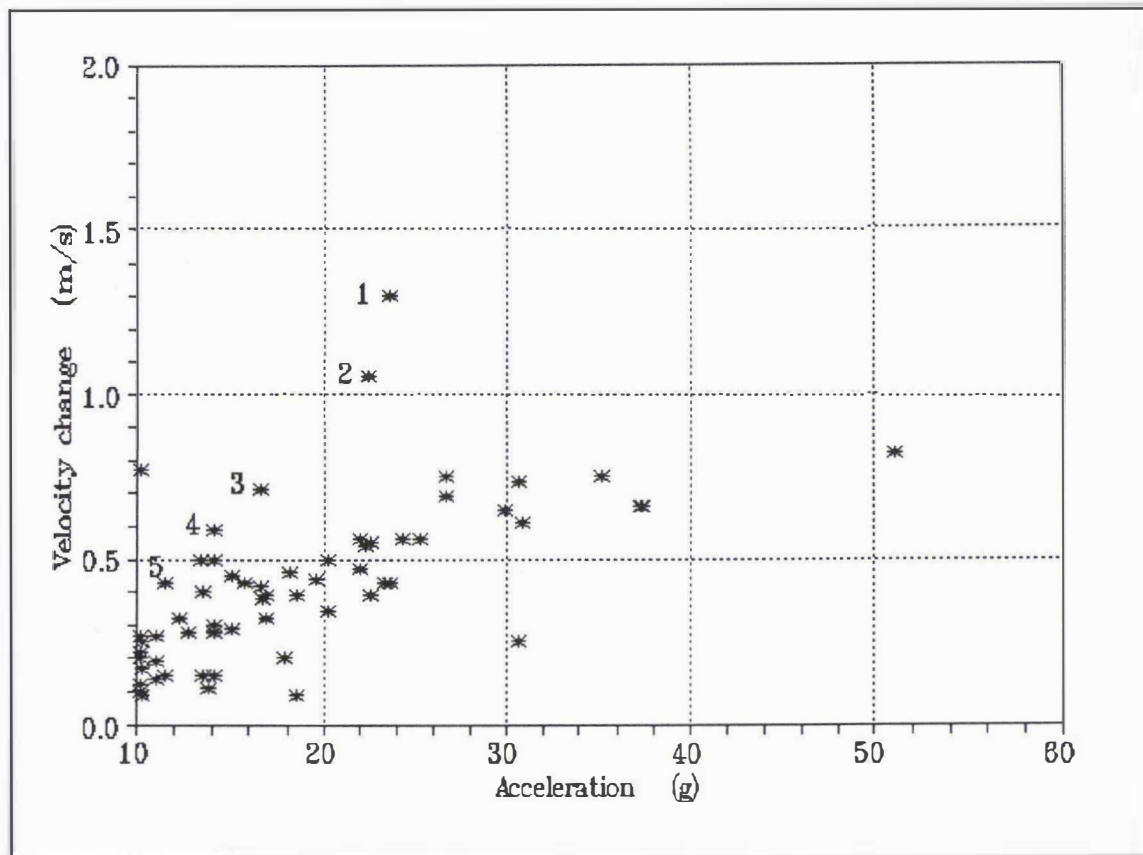

Figure 4.12 Instrumented Sphere data resulting from the impacts produced as the sphere fell into a final size packing bin, during commercial grading operations on Gala apples

4.7 Discussion

The method of analyzing fruit bruising by using an IS supplied by the manufacturers was based on some assumptions. It was based on measurements on fruit cultivars grown in the USA, which may not reflect the behaviours of other cultivars. In addition it only considers impacts on flat hard surfaces and cushioning materials with rigid backing surfaces that fruit may meet in a handling operation. In a survey of bruise sources on New Zealand grading equipment, Banks (1991) found that generally drop heights did not exceed 30 cm and that where large drops occurred damage was usually prevented by padding materials. However, small drop impacts onto hard surfaces and apple-to-apple impacts often caused more bruising which

exceeded the commercial standard of bruise size for export.

The acceleration and velocity change in an impact is governed by the nature of the two impact objects. During the analysis of fruit bruising using an Instrumented Sphere two different situations are involved -- the impact of the IS against the components of handling equipment, and the impact of fruit against the components. To correlate fruit bruising with IS output, the IS must be assumed to represent a fruit when it impacts onto the components of the equipment. Therefore, the actual impacts of fruit against different components of handling equipment must be considered. To establish a reliable bruise threshold line or boundary, the velocity change must be altered using the whole range of impact surfaces which fruit meet in a handling operation. Using different padding materials alone to alter the velocity change may not be the most appropriate way to determine the fruit bruise threshold curves.

In order to make the Instrumented Sphere fully useful in practice, it is necessary to study the components of handling equipment and the bruise damage as found in actual handling operations. The range of peak acceleration found in a New Zealand handling system was up to 130 g, but the bruise threshold line obtained from the manufacturers was well beyond this range (e.g. 25 g to 250 g for 'McIntosh' (Schulte-Pason et al., 1992)).

The duration of the impact pulse given by the IS was essentially determined by the length of leader and trailer. The total number of sample points for a common impact pulse recorded by the IS was around 30. If the length of leader and trailer were preset for too long a duration, the recorded value was meaningless. A practical length of 5, both for leader and trailer length, was selected after several trials and was used in all subsequent studies.

In the work described in the following 2 chapters, free impacts of fruit on fruit, and the impacts of fruit against another fruit supported by a padding material, are studied, to give a basic understanding of fruit-to-fruit impacts, and also to consider the potential of using the IS to predict bruise damage in fruit-to-fruit impacts.

4.8 Conclusions

From the discussion above, the following conclusions can be drawn.

1. The calibration file and the repeatability at different axes should be rechecked before use.
2. The preset length of 5 for leader and trailer was recommended under New Zealand conditions.
3. Apple-to-apple impacts and non-flat hard impact surfaces should be included in the analysis of bruise threshold.
4. A bruise boundary for using Instrumented Sphere should be developed using local fruit.

5. BRUISING DAMAGE IN APPLE-TO-APPLE IMPACT

The major sections of this Chapter have been published in the Journal of Agricultural Engineering Research, 52(4): 229-240 (1992).

5.1. Introduction

When an apple was dropped onto another apple or apples, several bruises usually resulted. Gaston and Levin (1951) reported that when a falling apple impacted onto another apple the damage is likely to be considerably greater than it would have had the falling apple impacted onto a flat surface. Field studies of handling systems (Banks, 1991; Bollen and Dela Rue, 1990) have also shown that most bruising occurred as a result of impacts against a variety of surfaces, and particularly during impacts with other apples as discussed in Chapter 2.

There have been several studies into bruising between apples stacked in columns, and the implications of this type of bruising to transportation and bulk storage have been considered (Schoorl and Holt, 1974; Holt and Schoorl 1985; Holt and Schoorl, 1984; Holt et al., 1981). These studies showed that energy absorption was a good indicator of total bruising. However, relatively few studies have been reported on apple-to-apple impact where both apples are free to move, and impacts between apples during sorting, grading, and packing operations have also received relatively little experimental attention.

As discussed in Chapter 2, while bruise volume may be important, surface area or bruise diameter is of more interest to the industry. It is therefore important to attempt to determine the surface area affected by an impact, as well as total bruise volume.

The objectives of this study were therefore to examine the relationship between physical parameters including bruise volume, contact surface area, impact energy, coefficient of restitution, and the energy absorbed in free apple-to-apple impact. The study also considered whether elasticity theory could be used to predict the trend in bruise area as a function of impact energy to the two-fifths power, in the case of apple-to-apple impact as discussed in Chapter 2.

5.2. Materials and methods

5.2.1 Experimental details

Two apples were supported by thin nylon threads to form two pendulums hung from two horizontal wooden bars 2 m apart. Each apple was attached to two threads with a steel pin pushed through the apple cortex on either side of the apple, so that the apples were suspended 2 m below the bar, and able to swing freely in a vertical plane parallel to the two bars. After each impact both apples were rotated around the calyx-stem axis to enable them to impact at a different position each time. The distance between the two apples was adjusted so the apples just touched in the rest position. One apple was then swung back and allowed to strike the stationary apple, which was free to move after impact. The movement of the two apples was recorded with a video camera, and the recording was played back in slow motion in order to measure rebound angles.

5.3.2 Test procedure

Granny Smith apples were carefully hand picked from a New Zealand commercial orchard at harvesting time. A sample of thirty apples was selected at random for

apple-to-apple tests on the same day. They were sorted at random into pairs, and the weights were recorded individually. Apple weights ranged from 172 to 244 g. Most pairs of apples had not more than a 19% difference in mass, and the greatest difference was 40.9 g. To start the experiment, apples were hung at the ends of the two pendulums, with the calyx-stem axis horizontal. One apple was swung back by hand and released from a series of 20 different angles between 55° and 4°. Each pair of apples was impacted at least seven times at different points on their cheeks. Before dropping, one of the apples was smeared with ink, so that after impact the contact area could be measured on the second apple. After the impact the second apple was caught by hand to prevent a second impact. The contact area was generally ellipsoidal, and so the surface area was measured by determining the major and minor diameters of the ellipse.

5.2.3 Bruise evaluation

The bruises were allowed to discolour for 24 h, and then the degree of bruising was evaluated by making a longitudinal cut through the centre of the bruised region and measuring the maximum diameter (d) and depth of bruise (h_1 and h_2 as indicated in Figure 5.1). The curvature of the apple (R) was measured using a transparent scale. Following Holt and Schoorl (1977), the shape of the bruise below the contact plane was assumed to be a segment of a sphere for calculation purposes, so that the bruise volume of each bruising point was given by:

$$v = v_{a1} - v_{a2} = \frac{\pi(h_1 - x)}{24} (3d^2 + 4(h_1 - x)^2) - \frac{\pi(h_2 - x)}{24} (3d^2 + 4(h_2 - x)^2)$$

where v_{a1} is the total volume enclosed by the bruise as shown in Figure 5.1(a), v_{a2} is the unbruised region above the bruise zone (where it is non zero) as in Figure 5.1(b) and as discussed below, h_1 and h_2 are the maximum depths of volumes v_{a1}

and v_{a2} respectively, d is the bruise width, r is the radius of curvature of the apple, and x is the height of the apple above the contact plane and which can be calculated from:

$$x = R - \left(R^2 - \frac{d^2}{4} \right)^{1/2}$$

In some cases the bruise appeared as indicated in Figure 5.1(a), with $h_2 = 0$ and $v_{a2} = 0$ (which agrees with the method of Holt and Schoorl (1977) as discussed in Chapter 2). In other cases the bruise shape was as shown in Figure 5.1(b), with volume v_{a2} unbruised (which is different from Holt and Schoorl's). Equation 5 assumes the boundaries surrounding both regions are spherical.

5.3. Experimental results

5.3.1 Bruise volume

In most cases the shape of the bruise was as in Figure 5.1(a) (i.e. $v_{a2} = 0$). There were about 10% bruises with non-zero values of v_{a2} . It was found that the total bruise volume (ie. the sum of the bruise volume on both apples) was linearly related to the energy absorbed in the impacts ($R^2=0.94$) as shown in Figure 5.2. However no such correlation was found when bruising on the individual apples was considered. Instead, bruising was distributed at random between the two apples, so that generally bruising was more severe on one of the two apples involved in the impact. In some cases only one apple was damaged, even at large impact energies, while in others both apples were badly damaged.

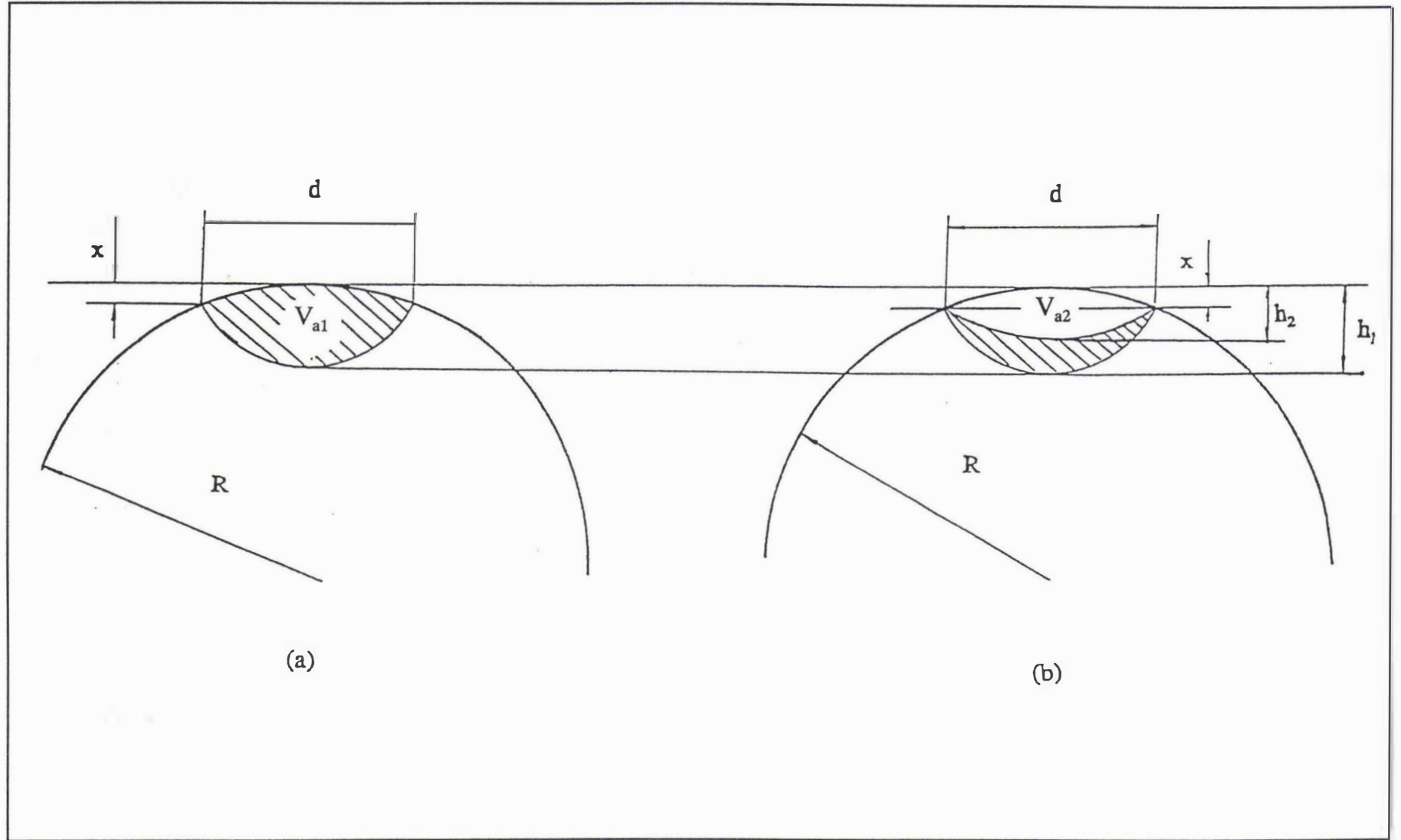

Figure 5.1

Cross-section of idealized bruise showing symbols used in bruise volume calculations. The shaded area represents the bruised region.

5.3.2 Contact area

The contact area and impact energy were related by a two-fifths power relationship as shown in Figure 5.3. The line is the best fit produced by linear regression was in agreement with the form of the relationship between contact area and impact

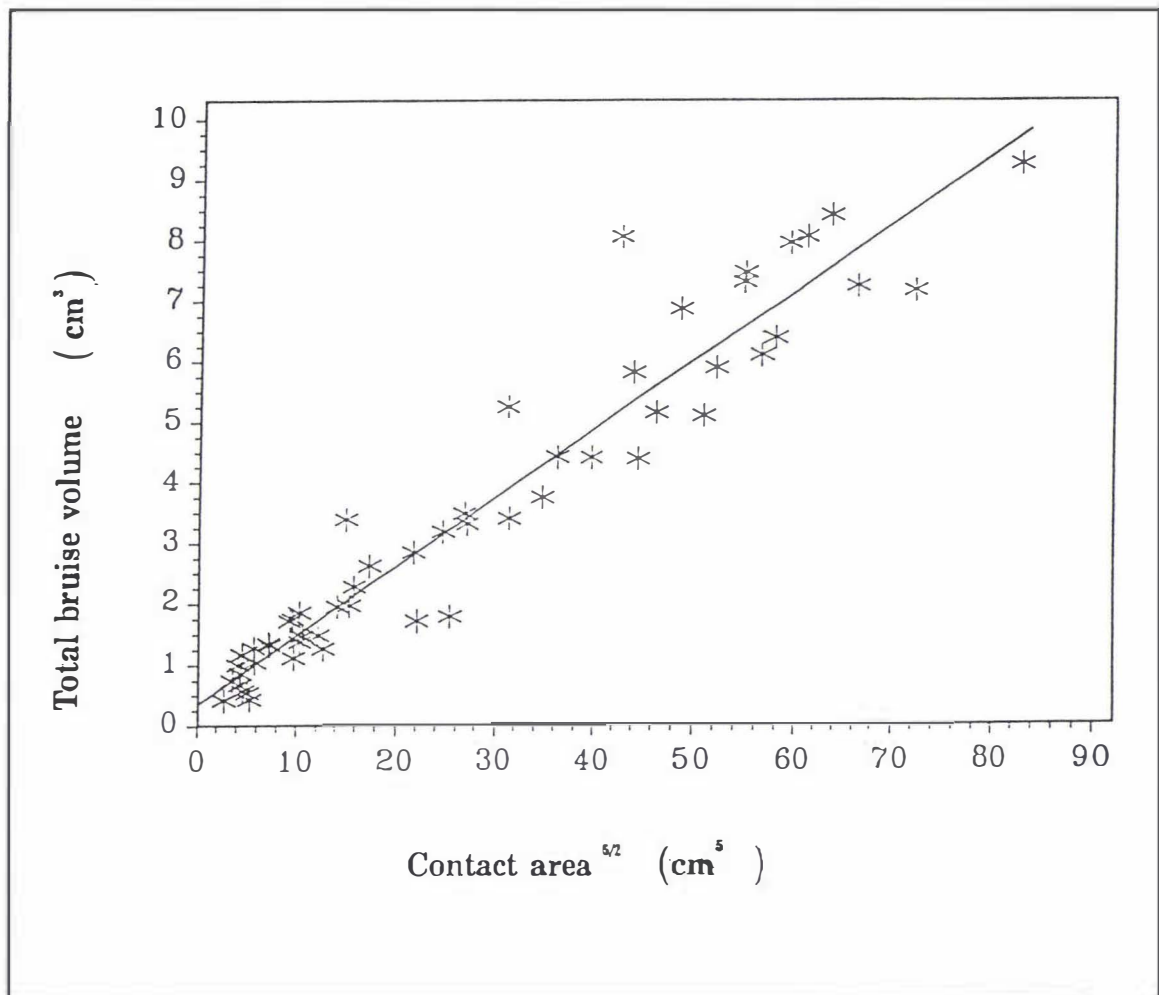

Figure 5.2 Total bruise volume versus $5/2$ power of contact area for the values of contact area $> 1.46 \text{ cm}^2$ for Granny Smith apples

energy predicted by the elastic model.

The relationship between the total bruise volume and contact area is shown in Figure 5.2 and Figure 5.5. Above 1.46 cm^2 , bruising was always detected, and the total bruise volume began to increase as a $5/2$ power function of the contact area,

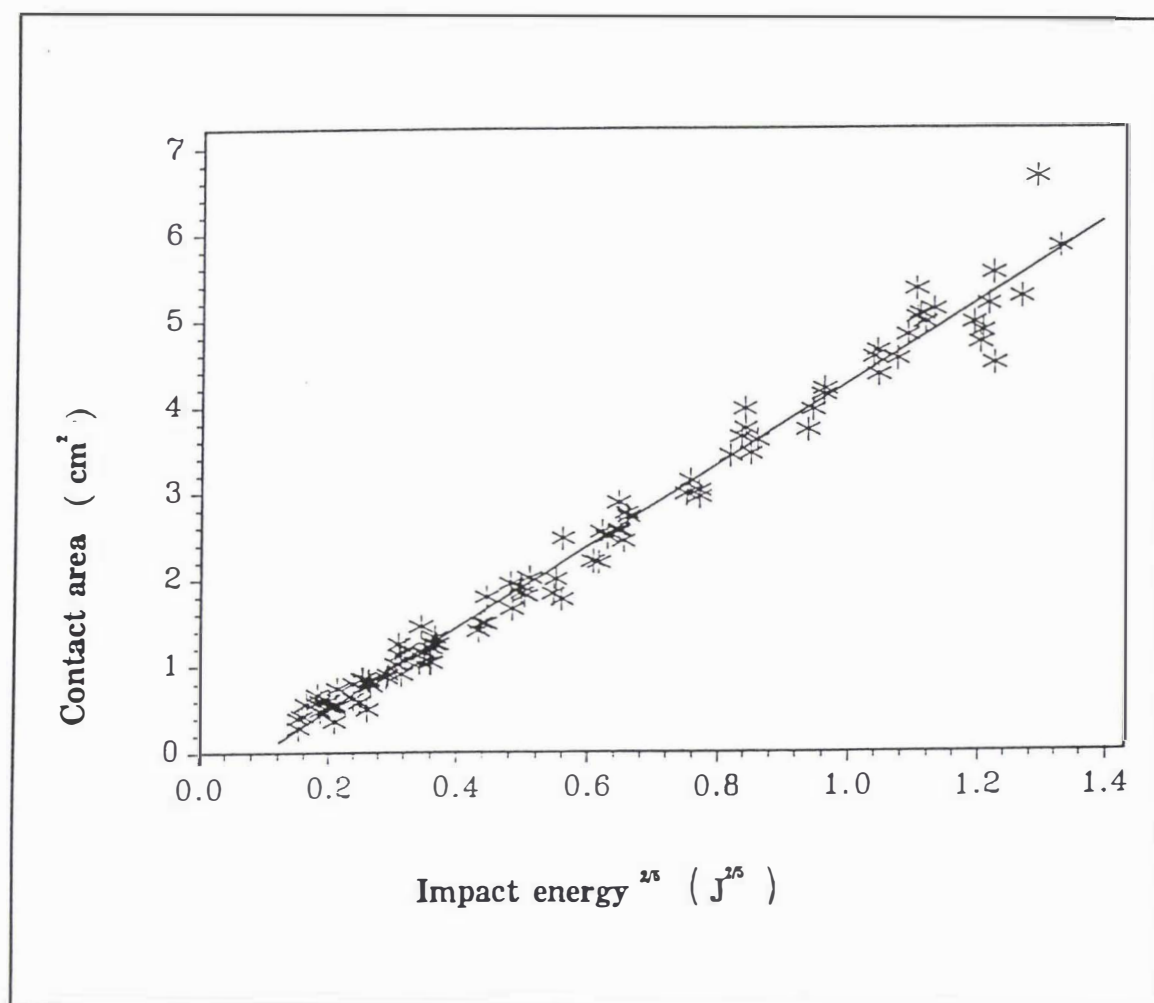

Figure 5.3 Contact area versus impact energy for Granny Smith apples

as the figure suggests (Figure 5.4, $R^2=0.95$). In the cases when the contact area was less than 0.75 cm^2 , bruising was detected in only one case out of seventeen (Figure 5.5). If the contact area was between 0.75 and 1.46 cm^2 , bruising was sometimes observed, but not in all cases as shown in Figure 5.5. While there was clearly a close relationship between bruise volume and contact area, the two were not completely correlated.

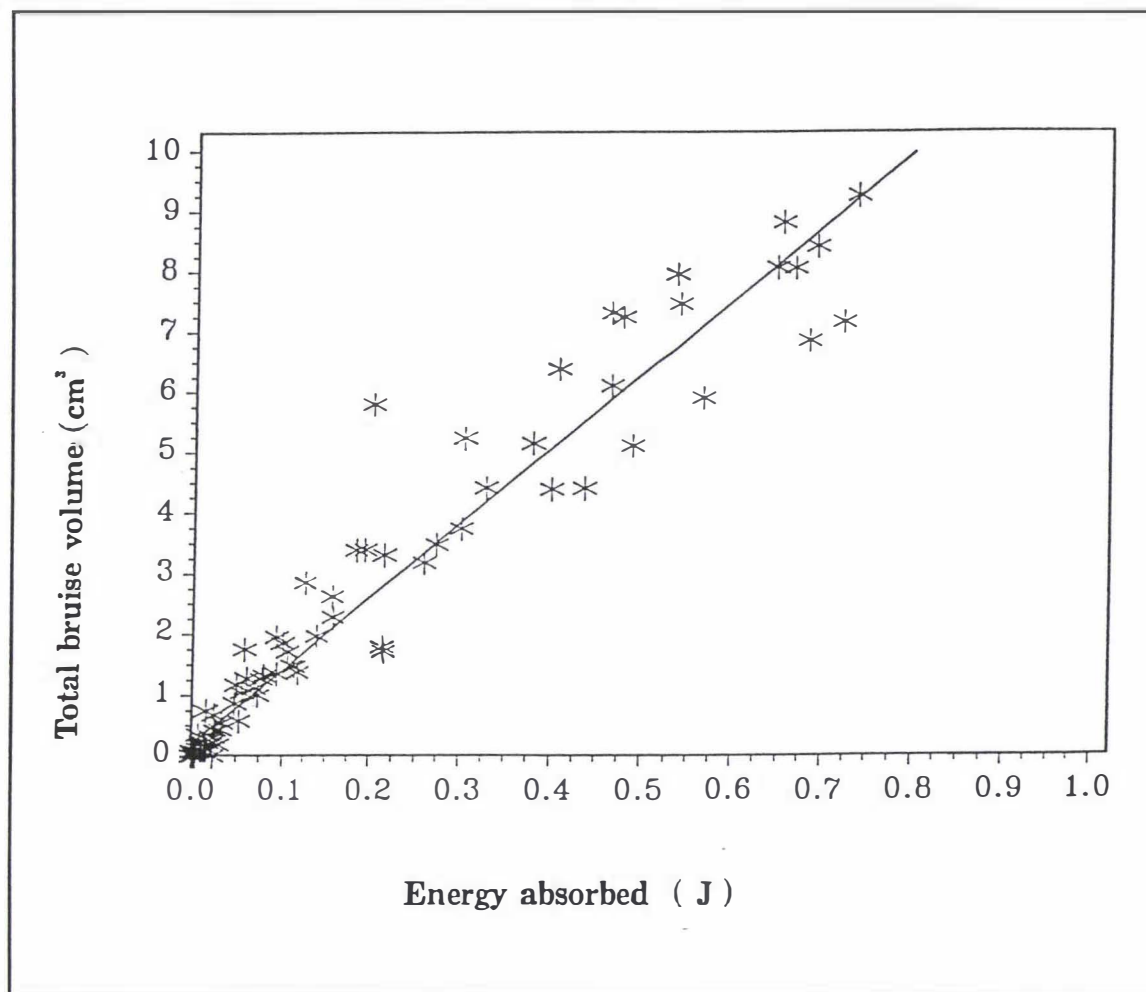

Figure 5.4

Total bruise volume versus energy absorbed for Granny Smith apples

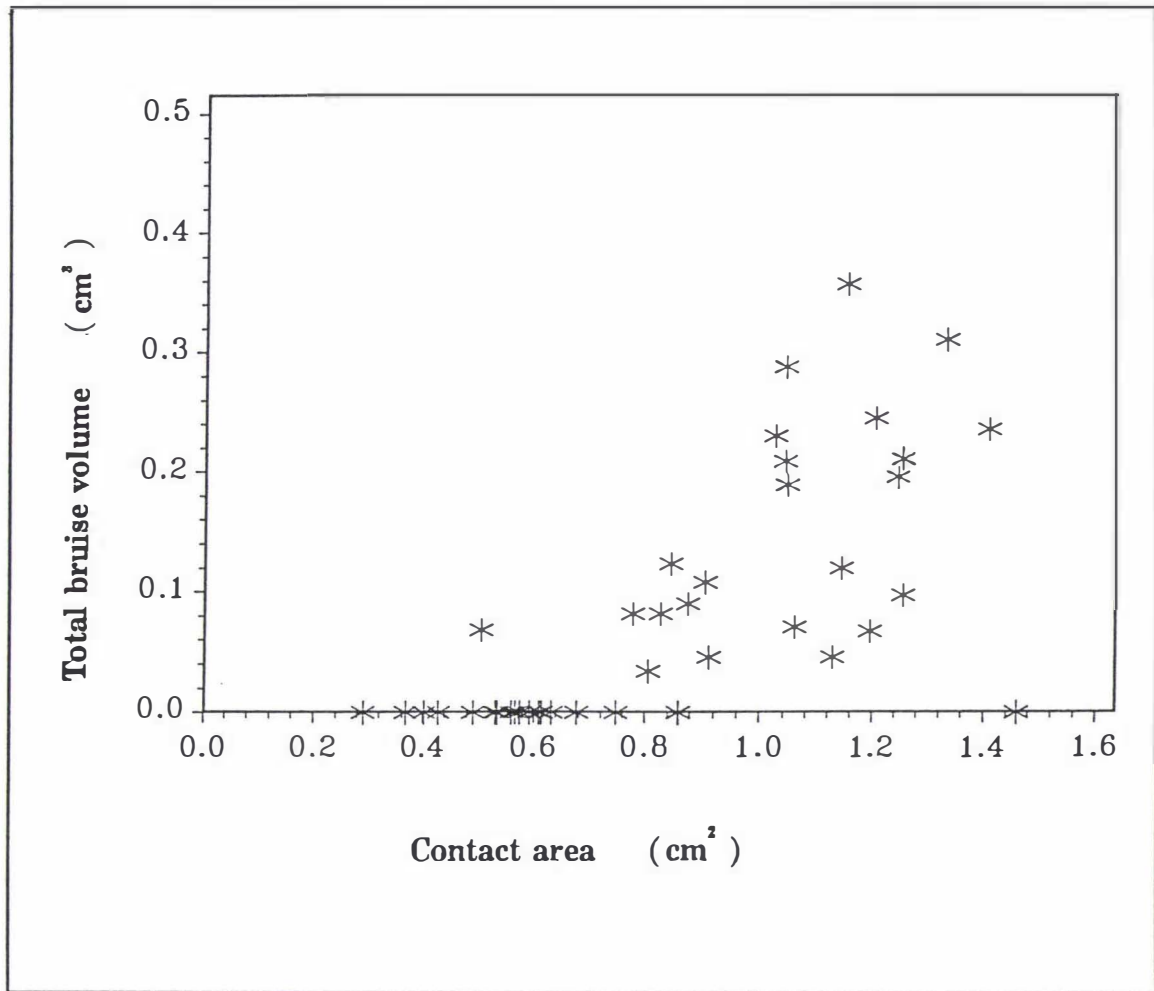

Figure 5.5 Total bruise volume versus contact area for the values of contact area $\leq 1.46 \text{ cm}^2$.

5.3.3 Coefficient of restitution

It was found that the coefficient of restitution (e) for apple-to-apple impact varied in a non-linear manner with the impact energy, decreasing as impact energy increased (Figure 5.6). In particular, the coefficient of restitution decreased sharply as the impact energy increased from zero to 0.2 J, and thereafter approached a constant value of around 0.48.

Thus as the impact energy decreased, the total bruising volume decreased and the

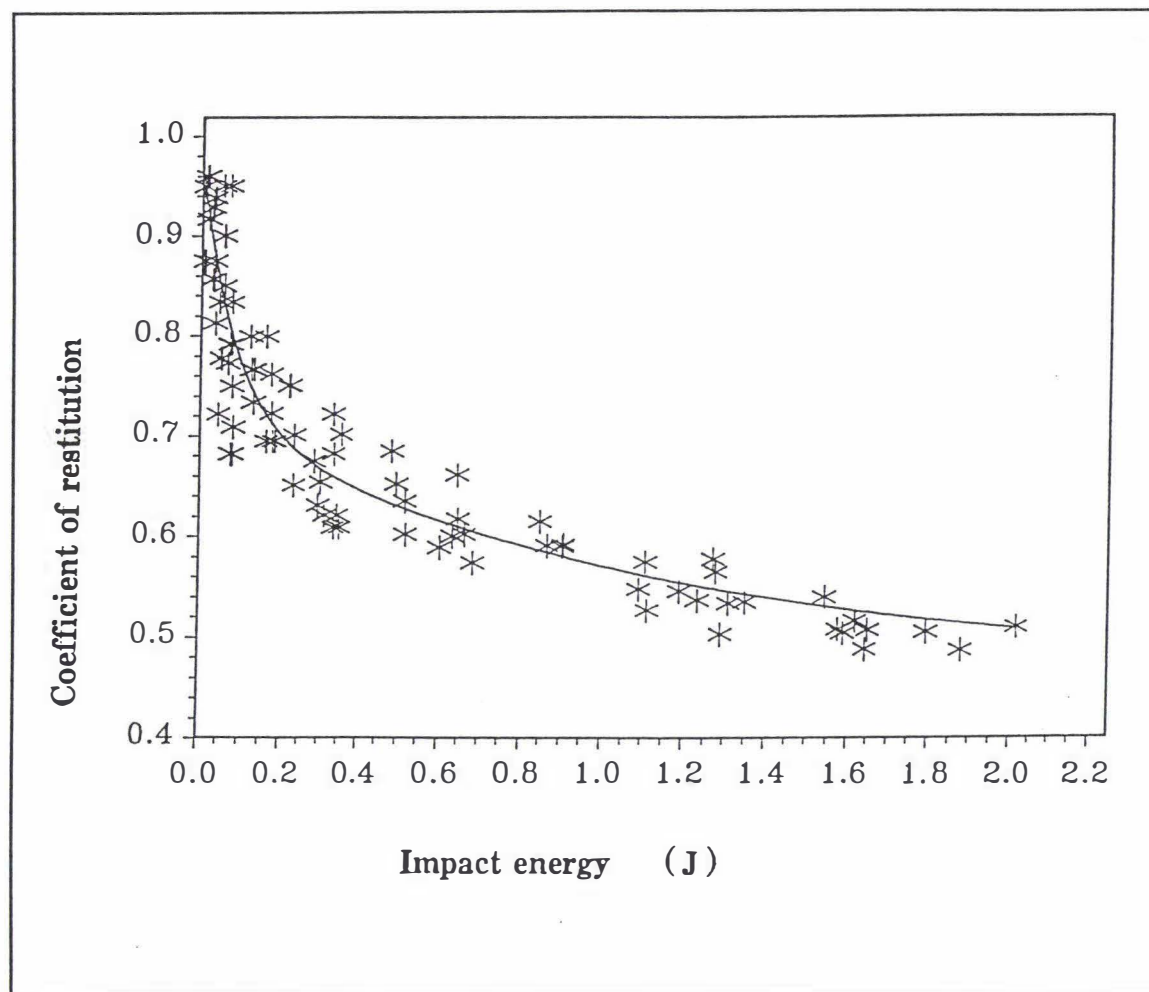

Figure 5.6 Coefficient of restitution versus impact energy for free apple-to-apple impact of Granny Smith apples

coefficient of restitution increased. The relationship between these two variables is shown in Figure 5.7. In all cases where the coefficient of restitution was less than 0.7, at least one apple was damaged. At values of e between 0.7 and 0.85 bruising was sometimes observed, but at values above 0.85 no bruising was detected.

The relationship between contact area and coefficient of restitution is shown in Figure 5.8. The contact area decreased with increasing coefficient of restitution. When e had a value of 0.8, the contact area was between 1 and 2 cm².

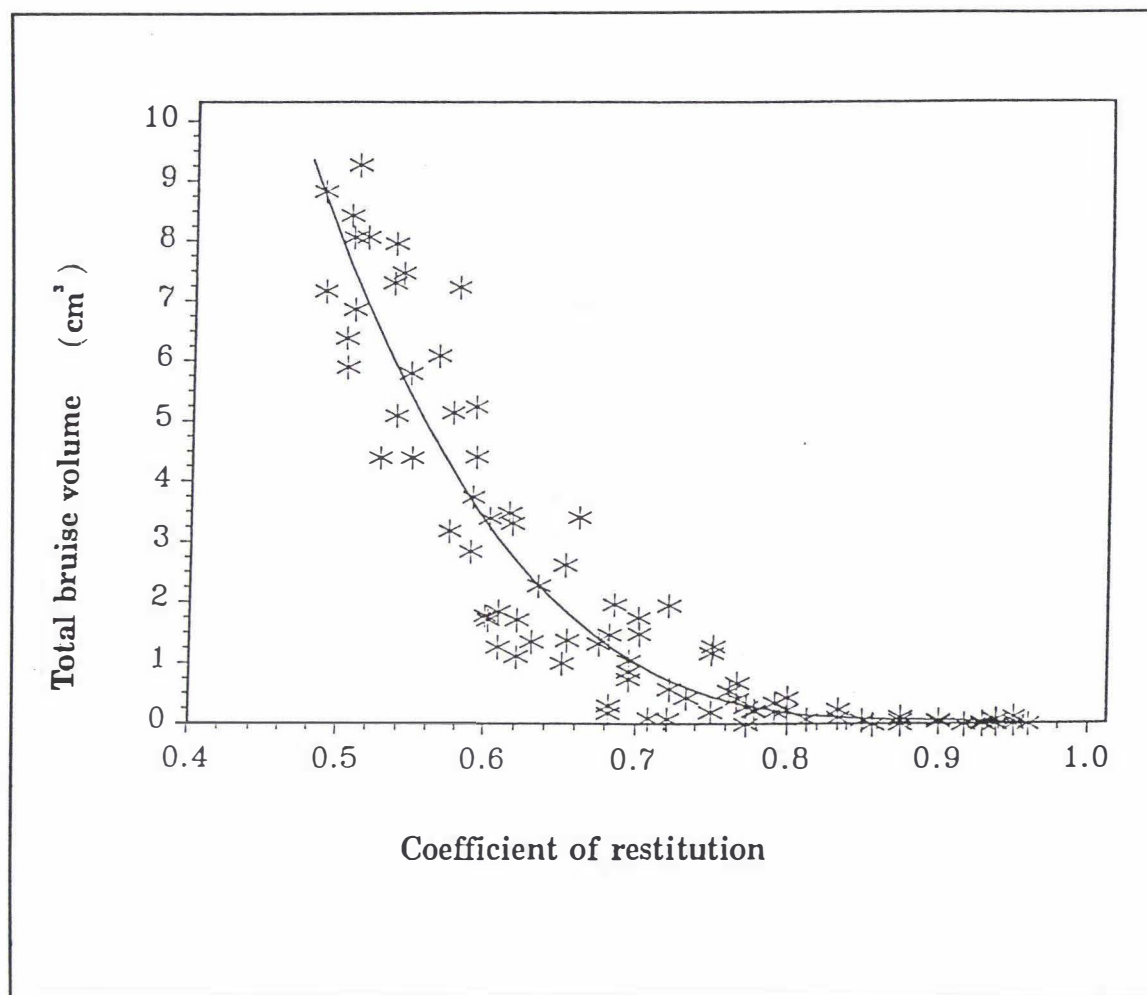

Figure 5.7 Total bruise volume versus coefficient of restitution during the free impact of apple-to-apple

5.4. Discussion

5.4.1 Total bruise volume and distribution between apples

In apple-to-apple impact, the experiments showed that the total bruise volume of the two apples was linearly correlated to energy absorbed in the impact. This is in agreement with the findings of Holt and Schoorl (1977) for the impact of a single apple onto a flat plate. While the total bruise volume produced in apple-to-apple impact was proportional to impact energy, the volume of damage in each apple

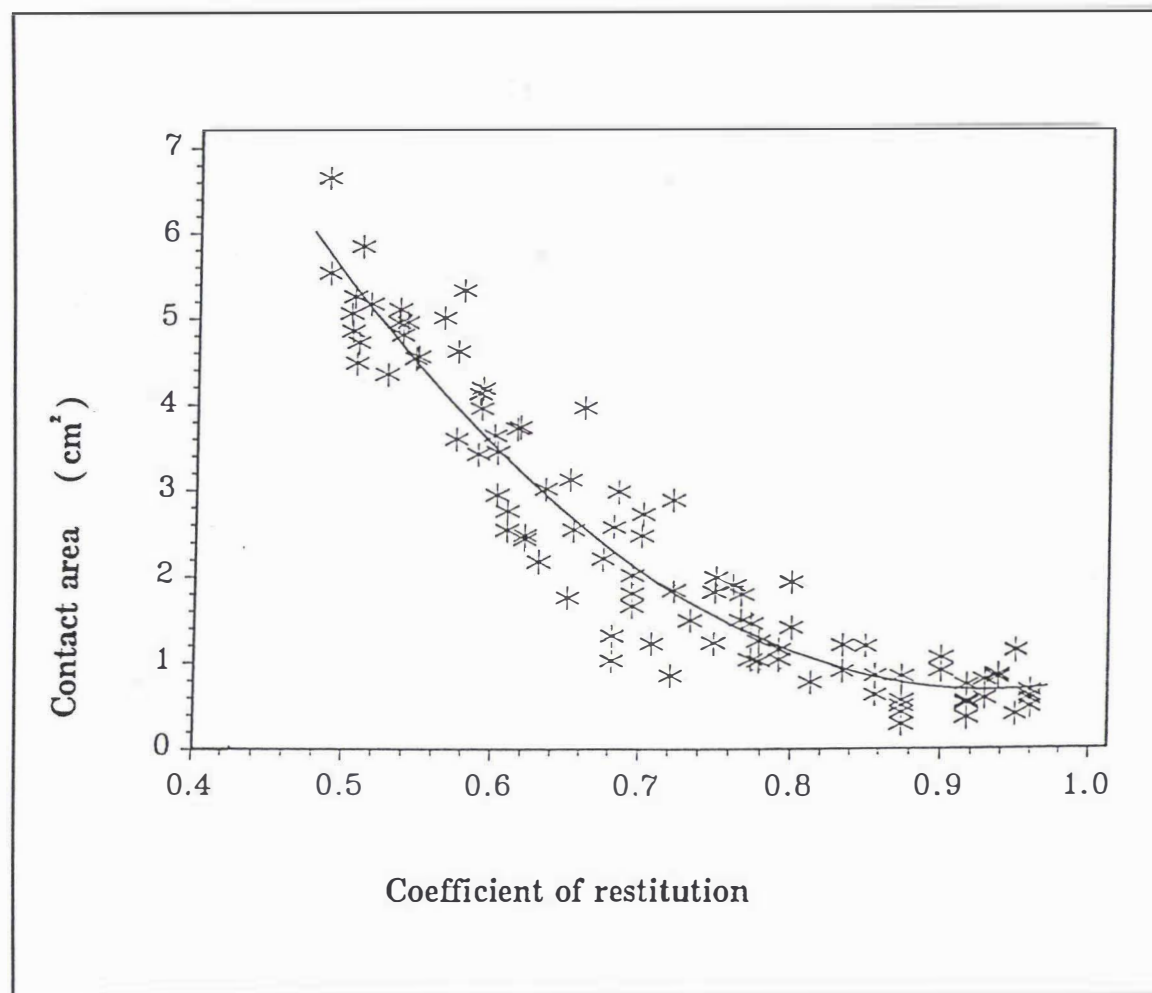

Figure 5.8 Contact area versus coefficient of restitution

varied considerably. It appears that in apple-to-apple impacts bruising is also an energy absorbing mechanism, and so for a given impact energy, total bruise volume was reasonably constant. However, the size of a bruise on a given apple was not necessarily related to the energy absorbed. Where fruit are graded on the maximum size of a bruise, the most desirable result will depend on the total energy of the impact. At high energies it would be better if one apple absorbed all the damage. At lower energies this could be the worst case, since the one damaged apple might be rejected, while if the bruising was equally distributed, then both apples could be slightly damaged, but at a less than critical level for grading purposes.

It is suggested that in free apple-to-apple impacts, if the yield points of the two apples were different, the apple with the lowest value would fail first and absorb more energy. Thereafter it would continue to fail as the force increased during the impact, while the other apple would be more likely to remain in an unbruised or only slightly bruised state. This leads to the interesting possibility that variations in the level of bruising sustained by different apple cultivars, as reported by packing shed operators, may be due to a wide range in yield point values of the apple flesh amongst a given crop, rather than inherent cultivar differences in impact bruise susceptibility. It is known that the mechanical properties of some apple cultivars (particularly Gala and other red or striped apples) vary from one side of the apple to the other, depending upon the orientation of the fruit on the tree to the sun (Studman, 1990). In other varieties (e.g. Granny Smith) this variation is less evident. This would explain the discrepancies between researchers who report only minor differences in bruise susceptibility values for different varieties (e.g. Klein, 1987), and packers (Howard, 1990) who repeatedly indicate that some varieties are much more easily bruised than others. However as discussed in Chapters 2 and 9, it may be the testing method which is producing the disagreement.

5.4.2 Contact area

Contact area plays an important role in impact theory and it is a visible and easily measured variable in practical situations. Elasticity theory suggests that the contact area of the impact is related to the impact energy, modulus of elasticity, and radii of the impacted objects. Assuming that the modulus term and radius term are unchanged, then theory suggests (Eq. 2.16) that the contact area is proportional to an energy term, $(mgh)^{2/5}$. In these experiments, when contact area was plotted against the $2/5$ power of impact energy, the result was a linear relationship ($R^2=0.98$, Figure 5.3). Thus elasticity theory appears to give a reasonable indication of the variation of contact area with impact energy during apple-to-apple

impact over the range of energies tested.

Experimentally, total bruise volume was directly proportional to the energy absorbed in the impact as described above. Using this linear relationship between absorbed energy and total bruise volume, it would appear that contact area and bruise volume should also be related by a similar power relationship. This is demonstrated experimentally in Figure 5.4, which is the plot of total bruise volume against $5/2$ power of contact area. Thus, contact area can also be used as a measure of bruise volume. Since contact area is relatively easy to measure, this could be a useful approach to large scale rapid experimental estimation of bruise susceptibility.

5.4.3 Bruise surface area

In this experiment the relationship of bruise surface area to contact area has not been considered because the technique for measuring the bruise volume did not take account of the ellipsoidal shape of the bruise area as described in Section 5.2.3. The relationship between the contact area and bruise area for apple-to-apple impact requires further study. This is a particularly important parameter in practice since bruise surface area is used for all grading purposes.

5.4.4 Coefficient of restitution

The value of the coefficient of restitution (e) depended on the magnitude of the impact. Since e is related to the level of elasticity of an impact, a low value implies that significant non-elastic processes are occurring. For a fully elastic impact $e = 1$, while for fully plastic impact there is no rebound and $e = 0$. This was confirmed by

the low occurrence of measured bruising when the value of e was above 0.7 (Figure 5.7). The sharp change in slope of the plot of e against impact energy (Figure 5.6) gives some indication of the level of impact energy at which damage is being done to the fruit, and could be used as a measure of the threshold level for bruising in apple-to-apple impact. However this approach would require further study. In particular the relationship between bruise area and e would need to be explored.

5.4.5 Use of elasticity theory to predict apple-to-apple bruising

In view of the ability of elasticity theory to predict contact area and bruise surface area, it is appropriate to apply this theory to various situations occurring in practice. According to elasticity theory as described in Chapter 2, the contact area is directly proportional to various fractional powers of the energy, radii, and moduli. Various cases can be considered. In the case where one apple is dropped from a height h , impacting onto a rigid flat plate with a large mass compared with the mass of the dropping apple, R_2 , E_2 , and m_2 can be considered infinite, and the contact area becomes:

$$A_1 = C (m_1 g h)^{2/5} \quad \dots\dots\dots(5.3)$$

where

$$C = \pi \left(\frac{15}{8 \pi} (1 - \nu^2) \frac{R_1^2}{E_1} \right)^{2/5} \quad \dots\dots\dots(5.4)$$

While free fruit-to-fruit impact has been examined, the impact of fruit to other fruit supported by hard surface or padding material (fruit-to-fruit impact thereafter) has not been fully studied, although the importance of bruising caused by such impacts

has been realised in studies of bruising during postharvest handling (Bollen and Dela Rue, 1991; Banks, 1991). However some guidelines can be deduced from the above analysis. If the falling apple drops onto a rigidly supported apple, and the radius of that apple is the same as the dropping apple, then taking $R_1 = R_2$, $E_2 = E_1$ and m_2 equal to infinity, it is straightforward to show that

$$A_2 = C \left(\frac{m_1 g h}{2} \right)^{2/5} = 0.76 A_1 \quad \dots\dots(5.5)$$

In comparison, if the second apple is free to move as in the experiments described above, so that

$$R_1 = R_2, \quad E_1 = E_2, \quad \text{and} \quad m_1 = m_2, \quad \text{then}$$

$$A_3 = C \left(\frac{m_1 g h}{4} \right)^{2/5} = 0.57 A_1 \quad \dots\dots(5.6)$$

These results for three different situations show that contact area and hence bruising area will vary at the same impact energy level by up to a factor of just under two depending on the situation. When these are converted to impact energy, it shows that compared with impact on a rigid plate, fruit can be dropped twice as far onto a supported fruit, or four times as far onto an unsupported fruit, to give the same contact area. On the other hand analysis shows that contact areas will be reduced by only 24% compared to striking a steel surface, when an apple impacts another apple which is unable to move. While great care is taken to avoid fruit impacts on bare steel surfaces, apple-to-apple impacts are relatively common in fruit handling operations, and it is not surprising that they are responsible for significant quantities of bruising.

5.5. Conclusions

In free impact of apple-to-apple situations, the bruise volume was generally more severe on one of the two apples. In some cases, one apple was damaged; rarely were both apples damaged equally. The ratio of bruise volumes between the two apples varied at random, and was not related to the magnitude of the impact. There was no correlation between the bruise volumes of the individual apples and the energy lost during the impact, but there was a strong linear relationship between the sum of the bruise volumes for the two apples and the energy absorbed.

It is suggested that differences in the apparent ease of bruising of some varieties reported by growers may be more due to variations of fruit physical yield strength around each fruit or between fruit in the same crop, than to absolute values of bruise susceptibility.

It was found that contact area could be used as a measure of bruising volume, since there was a two fifths power relationship between them.

The coefficient of restitution for apple-to-apple impact varied in a non-linear manner with impact energy. It decreased sharply in the impact energy range from 0 to 0.2 J, while above 0.2 J, it approached a constant value of 0.48.

While the coefficient of restitution could be used as an indication of threshold levels for significant bruising, further work would be required to establish its relationship to bruise surface area.

6. ANALYSIS OF DAMAGE THRESHOLDS IN APPLE-TO-APPLE IMPACTS USING AN INSTRUMENTED SPHERE

The major sections of this Chapter have been published in The New Zealand Journal of Crop and Horticultural Science. Volume 20(2): 159-166 (1992).

6.1 Introduction

From the results of Chapter 2 and Chapter 4, it can be seen that the Instrumented Sphere is a useful tool to predict the bruise potential of a fruit handling system. It should also be noted that apple-to-apple impacts are specifically excluded using the IS in the bruise threshold analysis. This is because all data points fall well to the left of the rising curve, in a region where the analysis suggests that no bruising will occur (see Chapter 2). Although a number of papers have been presented which discuss the use of the IS to predict bruising of fruit against hard and padded surfaces, very little comparable data has been published for apple-to-apple impacts as discussed in Chapter 5.

Since bruise surface area or bruise diameter is of more interest to the industry, it is important to investigate how the IS predicts fruit bruising produced by impacts of fruit-to-fruit in terms of surface area, rather than bruise volume.

The purposes of the work described in this Chapter were to investigate the relationship between the bruise area both with skin on and skin removed and other related parameters during fruit-to-fruit impact, and to examine the relationship between bruise area and IS output for predicting damage thresholds using an IS.

6.2 Materials and methods

6.2.1 Fruit preparation

Freshly picked Gala, Splendour, Braeburn, Fuji, and Granny Smith apples were selected at their respective commercial harvest dates from Hawke's Bay orchards. For each variety, a sample of 15 apples was selected randomly from fruit collected. All fruit were tested within 24 hours of harvest. The weights were recorded individually, ranging from 187 to 204.1 g for Gala, 210.3 to 240.6 g for Splendour, 235.8 to 259.8 g for Fuji, 179.7 to 236.5 g for Braeburn, and 209.4 to 226.8 g for Granny Smith apples.

6.2.2 Experimental details

An apple was attached to two thin nylon lines using a rubber strip wrapped around the fruit, and suspended as a pendulum 3.56 metres long. The apple was able to move freely in a vertical plane towards a wall. Each apple could be rotated about the calyx-stem axis to give several impact positions. A second apple was held by hand against a vertical steel block covered with a 6.4 mm thick layer of Riser Foam¹ on the surface. The contact point of the two fruit was adjusted to give a normal impact in a vertical plane. The suspended apple was swung back and released from one of a number of different heights (5.6mm - 143.3mm) against the stationary apple. After impact the apple was caught by hand to prevent a second impact.

Five pairs of fruit were selected at random from the sample of 15 fruit. Five different drop heights were used giving bruise areas up to 3.5 cm². Each pair of

¹ Code: WM711, a PVC foam, manufactured by Nylex New Zealand Ltd. 82-84 Victoria St, Petone, New Zealand.

apples was subjected to five impacts from different drop heights. Before impact, the stationary apple of each pair was smeared with ink, so that the contact area on the other apple could be measured. The IS was dropped in turn onto the five remaining apples from the same series of drop heights.

The ink mark on the impacted apple was measured and wiped off after the test. Bruises were then allowed to discolour for 24 hours before their surface dimensions were measured. Then the apple skin in the impact zone was peeled off, and the bruise area with skin removed was determined.

Contact area or bruise area (A_{cb}) was generally ellipsoidal, so all areas were calculated from measurements of the major and minor diameters (d_1 and d_2) using the formula:-

$$A_{cb} = \frac{\pi d_1 d_2}{4}$$

6.3 Results

6.3.1 Bruise visibility

In the laboratory tests involving fruit-to-fruit impacts, bruises often could not be seen until the skin was removed. In the tests where bruising was produced, it was found that only 50% of bruises were visible on Gala apples without peeling the skin, 38% on Fuji, 48% on Granny Smith, and 82% on Splendour. No visible bruises were observed on Braeburn apples prior to peeling. However, after peeling, bruises were clearly visible in all varieties, and the bruise area measured after peeling was used in this study.

6.3.2 Relationship between bruising area, contact area, and impact energy

The relationship between the contact area and two-fifths power of impact energy for the five varieties are given in Table 6.1. Braeburn had the smallest contact area for a given impact energy.

Bruising was generally more severe on one of the two apples, and it was quite common for only one apple to be damaged. Bruise area of neither the stationary nor the moving apple individually was correlated closely with impact energy, and the total bruise area of the two fruit was not well correlated with the impact energy either. However, a two-fifths power relationship between the largest bruise area and impact energy was found. For example, Figure 6.1 shows the relationship for Splendour ($R^2=0.96$). The slope of the regression line was used as an indication of bruise potential ($\text{cm}^2/\text{J}^{2/5}$) for each variety. The regression equations of the five different varieties are shown in Table 6.2. The residuals, slopes, and intercepts for Gala, Fuji, Splendour, and Granny Smith were not significantly different ($P>0.05$), but the slope for Braeburn was significantly different ($P<0.001$). The bruise potential of Braeburn apples was lower than that of other fruit tested, so that at the same impact energy levels there was less bruise area on Braeburn apples.

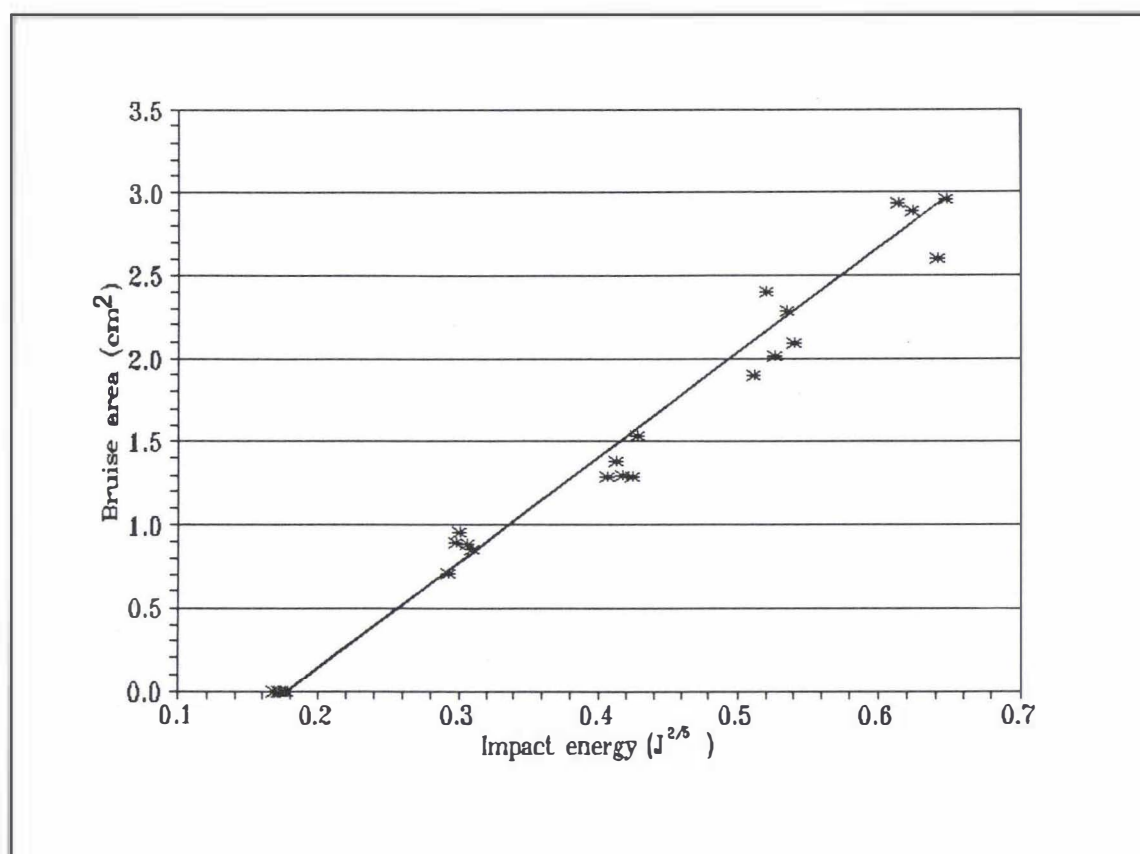

Figure 6.1 Largest bruise area after skin removal on either of two colliding apples plotted against two-fifths power of impact energy for Splendour apples

Table 6.1.

Linear relationship between contact area and two-fifths power of impact energy for different varieties of apple

| Variety | Regression equation | Coefficient of determination (R^2) |
|--------------|--|--|
| Gala | $A_c = 4.81(\pm 0.21)E_i^{2/5} - 0.71(\pm 0.15)$ | 0.96 |
| Splendour | $A_c = 5.35(\pm 0.22)E_i^{2/5} - 0.56(\pm 0.18)$ | 0.96 |
| Braeburn | $A_c = 3.01(\pm 0.15)E_i^{2/5} - 0.14(\pm 0.13)$ | 0.94 |
| Fuji | $A_c = 5.37(\pm 0.22)E_i^{2/5} - 0.41(\pm 0.19)$ | 0.96 |
| Granny Smith | $A_c = 4.63(\pm 0.14)E_i^{2/5} - 0.33(\pm 0.11)$ | 0.98 |

A_c = Contact area (cm^2),
 E_i = Impact energy (J).

Table 6.2.

Linear relationship between the bruise area and two-fifths power of impact energy for different varieties of apple

| Variety | Regression equation | Coefficient of determination (R^2) |
|--------------|---|--|
| Gala | $A_b = 7.08(\pm 0.39) E_i^{2/5} - 1.75(\pm 0.28)$ | 0.94 |
| Splendour | $A_b = 6.31(\pm 0.26) E_i^{2/5} - 1.12(\pm 0.21)$ | 0.96 |
| Braeburn | $A_b = 4.26(\pm 0.25) E_i^{2/5} - 0.84(\pm 0.21)$ | 0.92 |
| Fuji | $A_b = 7.31(\pm 0.39) E_i^{2/5} - 1.46(\pm 0.33)$ | 0.94 |
| Granny Smith | $A_b = 6.02(\pm 0.43) E_i^{2/5} - 0.97(\pm 0.34)$ | 0.95 |

A_b = Bruise area (cm^2),
 E_i = Impact energy (J).

The relationship between contact area and the largest bruise area depended upon the impact energy. At low energies with contact areas below 0.6 cm^2 , often no bruising was observed on either apple (e.g. Figure 6.2 which shows the results for Splendour, details of other varieties are presented in Appendix F). At higher impact energies there was a strong linear relationship between the largest bruise area of the two fruit and contact area (Figure 6.2). The coefficient of determination ranged from 0.93 to 0.98 for the five varieties (Table 6.3).

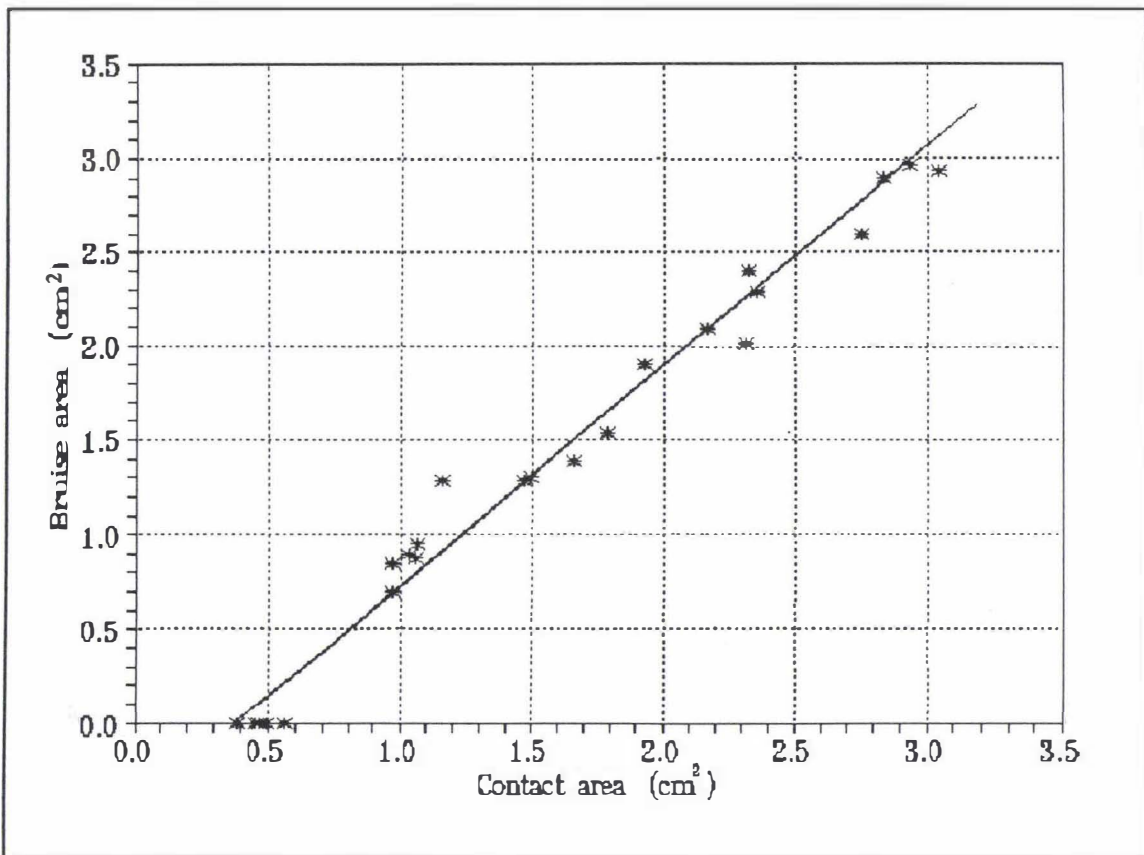

Figure 6.2 Largest bruise area on either of two colliding apples plotted against contact area for Splendour apples

Table 6.3.

Linear relationship between the bruise area and contact area for different varieties of apple*

| Variety | Regression equation | Coefficient of determination (R^2) |
|--------------|---|--|
| Gala | $A_b = 1.25(\pm 0.09) A_c - 0.30(\pm 0.31)$ | 0.93 |
| Splendour | $A_b = 1.01(\pm 0.03) A_c - 0.09(\pm 0.15)$ | 0.98 |
| Braeburn | $A_b = 1.01(\pm 0.06) A_c - 0.03(\pm 0.21)$ | 0.96 |
| Fuji | $A_b = 1.05(\pm 0.02) A_c - 0.08(\pm 0.14)$ | 0.97 |
| Granny Smith | $A_b = 1.07(\pm 0.05) A_c - 0.08(\pm 0.24)$ | 0.95 |

A_b = Bruise area (cm^2),

A_c = Contact area (cm^2).

* Excluding data where no bruising occurred

6.3.3 Instrumented Sphere output

There was a strong linear relationship between velocity change and peak acceleration recorded by the IS when it was dropped onto apples (R^2 ranged from 0.93 to 0.97 for the different varieties, Table 6.4). There were no significant differences between Gala, Splendour, Fuji, and Granny Smith apples in either slope or intercept of the regression equations ($P > 0.05$), but the intercept for Braeburn apples was significantly different from the others ($P < 0.001$). The velocity change was consistently lower at the same acceleration levels when the IS was dropped onto Braeburn apples.

Table 6.4.

An linear relationship between the velocity change and peak acceleration recorded by Instrumented Sphere during impact onto Gala, Splendour, Braeburn, Fuji, and Granny Smith apples

| Variety | Regression equation | Coefficient of determination (R^2) |
|--------------|--|--|
| Gala | VC = 0.05(\pm 0.004) PA - 0.16(\pm 0.12) | 0.97 |
| Splendour | VC = 0.06(\pm 0.004) PA - 0.22(\pm 0.21) | 0.93 |
| Braeburn | VC = 0.05(\pm 0.003) PA - 0.44(\pm 0.16) | 0.96 |
| Fuji | VC = 0.05(\pm 0.003) PA - 0.11(\pm 0.14) | 0.95 |
| Granny Smith | VC = 0.05(\pm 0.003) PA - 0.09(\pm 0.16) | 0.96 |

VC = Velocity change (m/s)

PA = Peak acceleration (g's)

6.3.4 Determination of bruise thresholds

For all varieties there was a linear relationship between the largest bruise area for each pair of apples and the g value recorded by the IS when dropped from the same height. Figure 6.3 shows the relationship for Splendour ($R^2=0.89$). The regression equations obtained were used to estimate the IS acceleration corresponding to the maximum acceptable bruise area (the bruise threshold) of 1 cm². The bruise threshold calculated in this way ranged from 21 g's to 33 g's for fruit-to-fruit impacts for the different varieties tested (Table 6.5). The equivalent drop heights, from which the maximum acceptable 1 cm² bruise area would be produced when an apple was dropped onto another fruit, ranged from a height of 3.25 cm for Splendour to 6.42 cm for Braeburn.

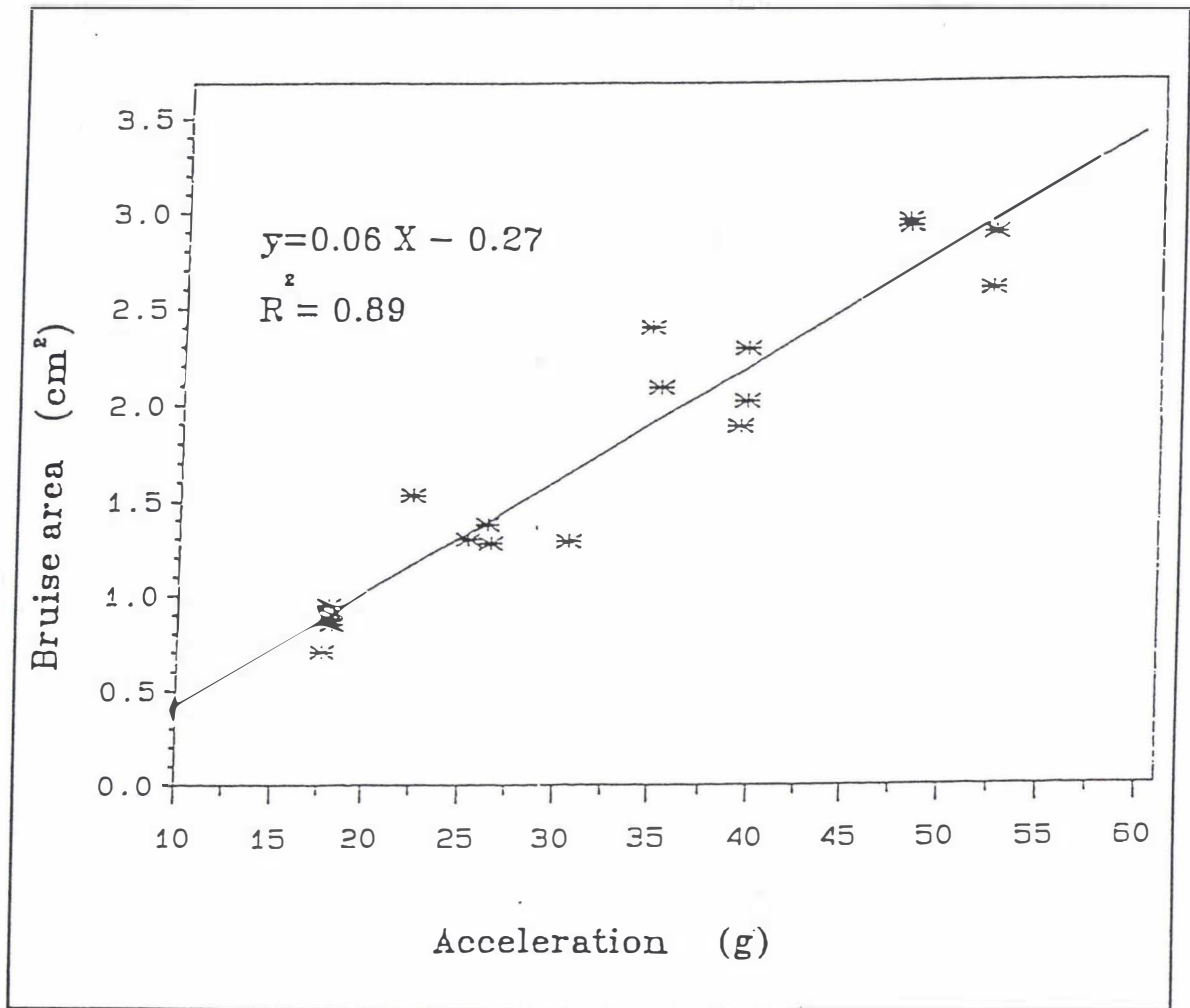

Figure 6.3 Largest bruise area on either of two Splendour apples in apple-to-apple impact plotted against peak acceleration recorded by the Instrumented Sphere when dropped from the same height

Table 6.5.

The linear relationship between bruise area and peak acceleration and bruise thresholds for fresh Gala, Splendour, Fuji, Braeburn, and Granny Smith apples in apple-to-apple impact (1991 season)

| Variety | Regression equation | Coefficient of determination R^2 | Bruise threshold (g) | Equivalent height (cm) |
|--------------|---|---------------------------------------|-------------------------|---------------------------|
| Gala | $A_b = 0.07(\pm 0.002) PA - 0.16(\pm 0.18)$ | 0.97 | 26 | 5.45 |
| Splendour | $A_b = 0.06(\pm 0.006) PA - 0.27(\pm 0.33)$ | 0.89 | 21 | 3.25 |
| Fuji | $A_b = 0.08(\pm 0.008) PA - 0.77(\pm 0.45)$ | 0.84 | 22 | 3.52 |
| Braeburn | $A_b = 0.05(\pm 0.003) PA - 0.67(\pm 0.16)$ | 0.91 | 33 | 6.42 |
| Granny Smith | $A_b = 0.06(\pm 0.007) PA - 0.28(\pm 0.39)$ | 0.83 | 21 | 3.69 |

A_b = Bruise area (cm^2),

PA = Peak acceleration (g) ($1g = 9.81 \text{ m/s}^2$)

6.3.5 Interpretation of Instrumented Sphere output

The impacts recorded by the IS as it passed from the sizer cup to the final size bin of a grading machine are shown in Figure 4.12. From the video recordings, points 1 to 5 occurred when the IS struck an apple. The values of peak acceleration and velocity change for these impacts appeared to be closely correlated, since the data points all lay close to a straight line. From the bruise threshold results, it was concluded that any impact of the IS onto an apple giving an acceleration larger than 21 g was likely to produce a bruise 1 cm² or greater in Granny Smith fruit as measured with skin removed (e.g. points 1 and 2 in Figure 4.12).

6.4 Discussion

Contact area plays an important role in impact theory and, experimentally, it is a visible and easily measured parameter in practical situations. The relationship between contact area and two-fifths power of impact energy confirms that elasticity theory can be used to determine the relationship between these two parameters. For energy levels sufficient to cause bruising, the largest bruise area measured after skin removal was highly correlated with the contact area. Thus the largest bruise area can be estimated directly from contact area using the proportionality constants given in Table 6.3.

For bruises above 1 cm², the largest bruise area of the two fruit was found to be linearly correlated with contact area (Figure 6.2). According to elasticity theory, the contact area is related to the 2/5 power of impact energy, and the experiment showed that the largest bruise area could be similarly correlated (eg. Figure 6.2). The slope of the regression line for the relationship between bruise area and the 2/5 power of the impact energy can therefore be used as a measure of bruise

potential similar to the general definition of bruise susceptibility (Schoorl and Holt, 1980; Studman and Banks, 1990). When the experiment was repeated for fresh Gala, Fuji, Braeburn, and Granny Smith, the results showed a similar linear relationship. This implied that the largest bruise area produced in apple-to-apple impact was linearly related to impact energy, and also that the contact area in the impact could be used as a measure of bruising area with skin removed. However, in low energy impacts which generated low contact areas, often no bruising occurred (Figure 6.2 and Appendix F).

The response lines on the graph of velocity change versus peak acceleration when the IS was dropped onto different varieties of apple were determined as shown in Table 6.4. When this data is combined with measurements of bruising in apple-to-apple impacts, it is possible to determine the point at which excessive bruising occurs (i.e. the bruise threshold) for these impacts. This information allows a prediction of which impact recorded by the IS, as it passes through a handling or grading system, will cause damage, and where bruise damage may occur in the grading process.

The original standard method for analyzing IS output (Schulte-Pason et al., 1990), which is illustrated in Figure 4.3, applies to impacts onto surfaces which are flat, and in which cushioning materials are supported by a rigid backing surface. The output of the IS is likely to be different for impacts onto the wide range of surfaces as it passes through a handling system. The method of determining the damage thresholds for fruit-to-fruit impacts described here could be used to determine the damage thresholds for impact onto other materials, and onto surfaces of different shapes and textures. Thus, surfaces likely to be used in practical situations can also be tested. In this way it may be possible to establish bruising levels for each surface and to determine zones on the velocity change-acceleration graph which indicate reliably the bruising region for impacts recorded by the IS during commercial

packing, where non-flat surfaces and apple-to-apple impacts are included in the evaluation.

In most postharvest systems, fruit are subjected to a large number of impacts. One major source is where a falling fruit impacts onto fixed hard surface or a padded surface. However, these impacts can be minimised by more padding, and by altering system design. The second source of impacts is fruit-to-fruit impacts. There are a large number of such impacts during sorting, grading, and packing, which can not easily be avoided with present equipment and handling methods. However, these impacts can be identified by the IS (as illustrated in Figures 6.3 and 4.12) and regions where bruising is likely to occur from fruit-to-fruit impacts can be identified and redesigned.

From the results of these experiments, it can be seen that if a Granny Smith apple is dropped from 3.69 cm onto another apple which is resting against a flat steel surface covered with 6.4 mm Riser Foam, a bruise area of 1 cm² would be produced as shown in Table 6.5.

The above analysis of bruise area is based on area measured after skin was removed, while current grading practice involves area assessment without skin removal. These experiments showed that bruising may not always be visible, particularly where the bruise arises from apple-to-apple impact. This issue requires further study, since it may have important implications for fruit quality issues.

6.5 Conclusions

Fruit-to-fruit impacts on commercial packing lines were simulated in the laboratory for pairs of fresh Gala, Splendour, Fuji, Braeburn, and Granny Smith apples by dropping one apple onto the other from a range of heights. Bruising was generally more severe on one of the two apples, and it was quite common for only one apple to be damaged. Contact areas above 1 cm² were closely related to bruise areas. Below this level bruising rarely occurred. Some bruises produced in apple-to-apple impacts were not visible unless the apple skin was removed. Braeburn apples required a greater drop height to produce a significant bruise than other varieties.

When the results of apple-to-apple and IS-to-apple impacts were compared, it was found that the area of the larger of the two bruises produced in fruit-to-fruit impacts was directly related to the peak acceleration recorded by the IS when it was dropped onto a fruit from the same height. Using this comparison, damage thresholds resulting from fruit-to-fruit impacts were determined by analyzing IS output.

The IS can be used to identify apple-to-apple impacts likely to cause bruising in commercial packing operations, providing care is taken with interpretation of the data.

7. USE OF AN INSTRUMENTED SPHERE FOR ASSESSING APPLE BRUISING THRESHOLDS

The major sections of this Chapter have been published In The American Society of Agricultural Engineers Papers, Paper No: 91-6596 (1991)

7.1 Introduction

In previous studies by other researchers, IS output was correlated to impact bruising on apples by a series of experiments which produced bruise threshold curves (e.g. Brown et al., 1987; Schulte-Pason et al., 1990). First, the sphere was dropped from a range of heights onto a series of flat surfaces with differing levels of padding. Next, fruit were dropped from the same range of heights onto the same surfaces. After 24 hours the fruit were examined for bruising and the bruise measured by peeling the skin. The surfaces were steel and different types of foam mounted to a steel substrate. In this way the velocity change for a given acceleration was varied. The tests with the IS generated a set of points which were plotted on a velocity change versus peak acceleration graph to produce impact response lines. The percentage of bruised fruit at each drop height was recorded and marked on these curves, at the point corresponding to the same drop height. Lines representing equal percentages of bruised fruit were then drawn to give bruise curves as described in Chapter 2. It was concluded that if an impact was recorded during experiments on an apple handling system, and the impact lay below and to the right of the curve, then bruising would have occurred on a fruit under similar circumstances.

A number of papers have been presented which discuss the use of the IS to predict bruising of fruit against flat steel surfaces, and padded flat surfaces, (Brown et al.,

1990; Schulte-Pason et al., 1990; Sober et al., 1989). Bruise thresholds for fruit-to-fruit impacts on different varieties of apple have been determined in Chapter 6. If the same method for determining bruise threshold is used on a variety of surfaces commonly used on fruit handling systems, an overall bruise threshold will be obtained which may be different from threshold curves obtained for steel surface and padding materials. Such a bruise threshold should be a better predictor of bruise damage, than those developed on a more limited range of surfaces.

In the experiments described in this chapter the relationship between bruise area peak IS acceleration and IS velocity change produced on fresh fruit impacted against different surfaces was examined. Damage threshold values for each surface tested were obtained, so that an overall potential bruise boundary could be established on the graph of velocity change versus peak acceleration generated by an IS for each variety of apple. Particular attention was given to apple-to-apple impacts.

The potential for using data of this type for characterising bruise susceptibility of a population of apples is examined with the data from this experiment in Chapter 8.

7.2 Materials and Methods

7.2.1 Experimental Details

In the laboratory, seven impact surfaces were selected to represent impact situations obtained from packing lines as shown in Figure 7.1. They were a flat steel surface, a 3 mm Neoprene rubber supported by a flat steel surface, a solid plastic bar 40 mm in diameter (for some varieties only), a plastic tube (2.66mm wall thickness) 40 mm in diameter,

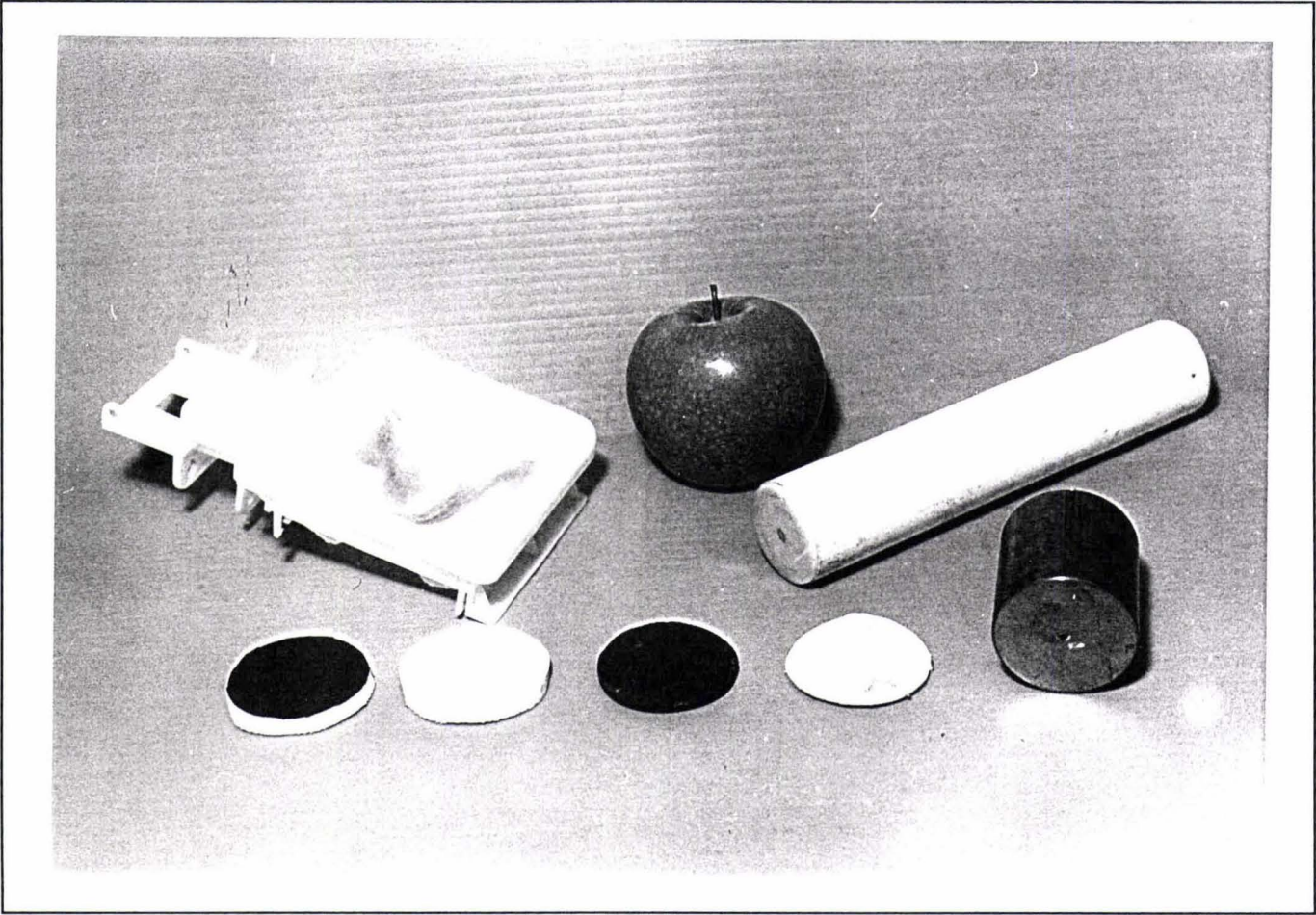

Figure 7.1 The different impact surfaces selected from local fruit grader manufacturer

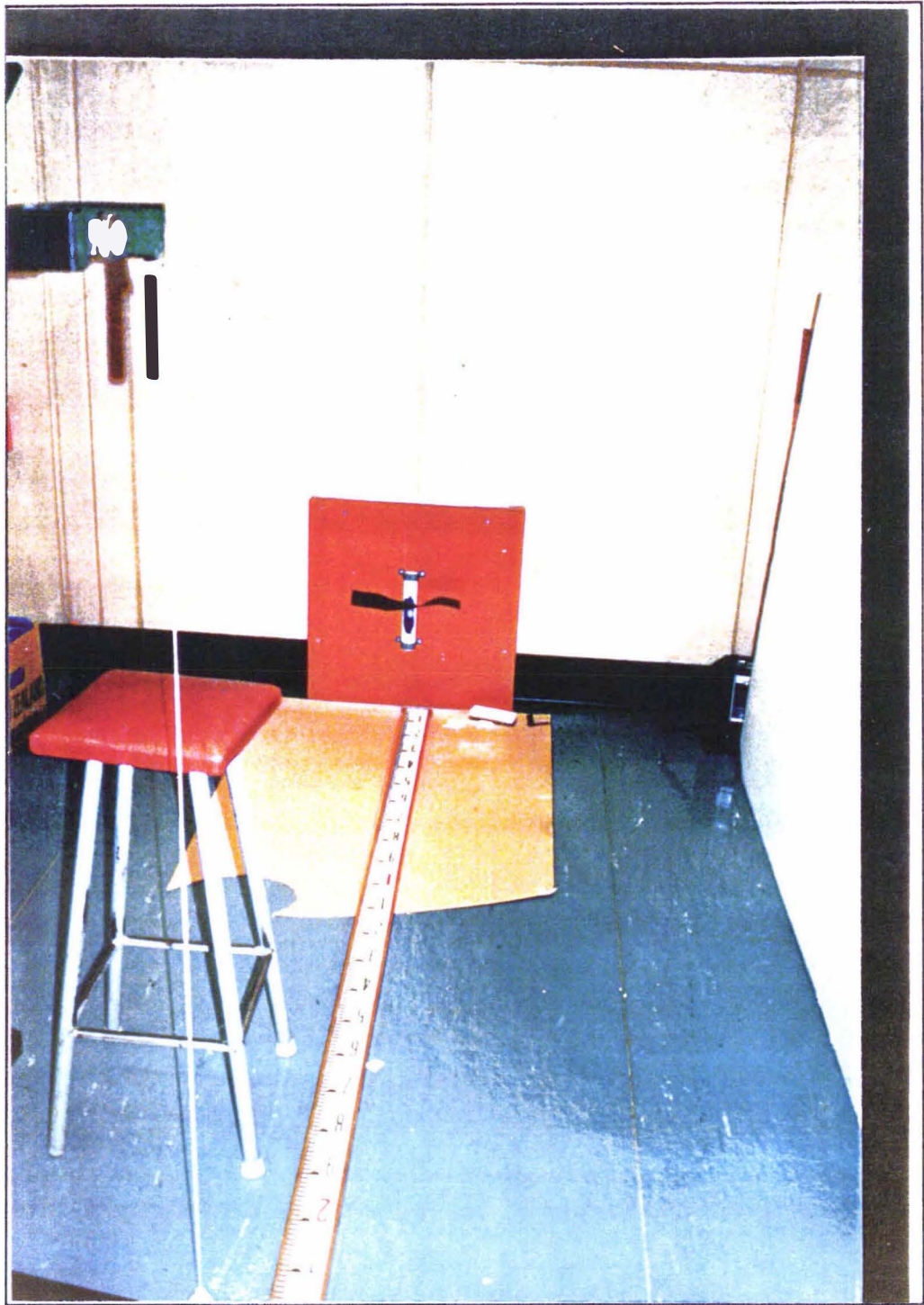

Figure 7.2 The wall pendulum system used in this experiment

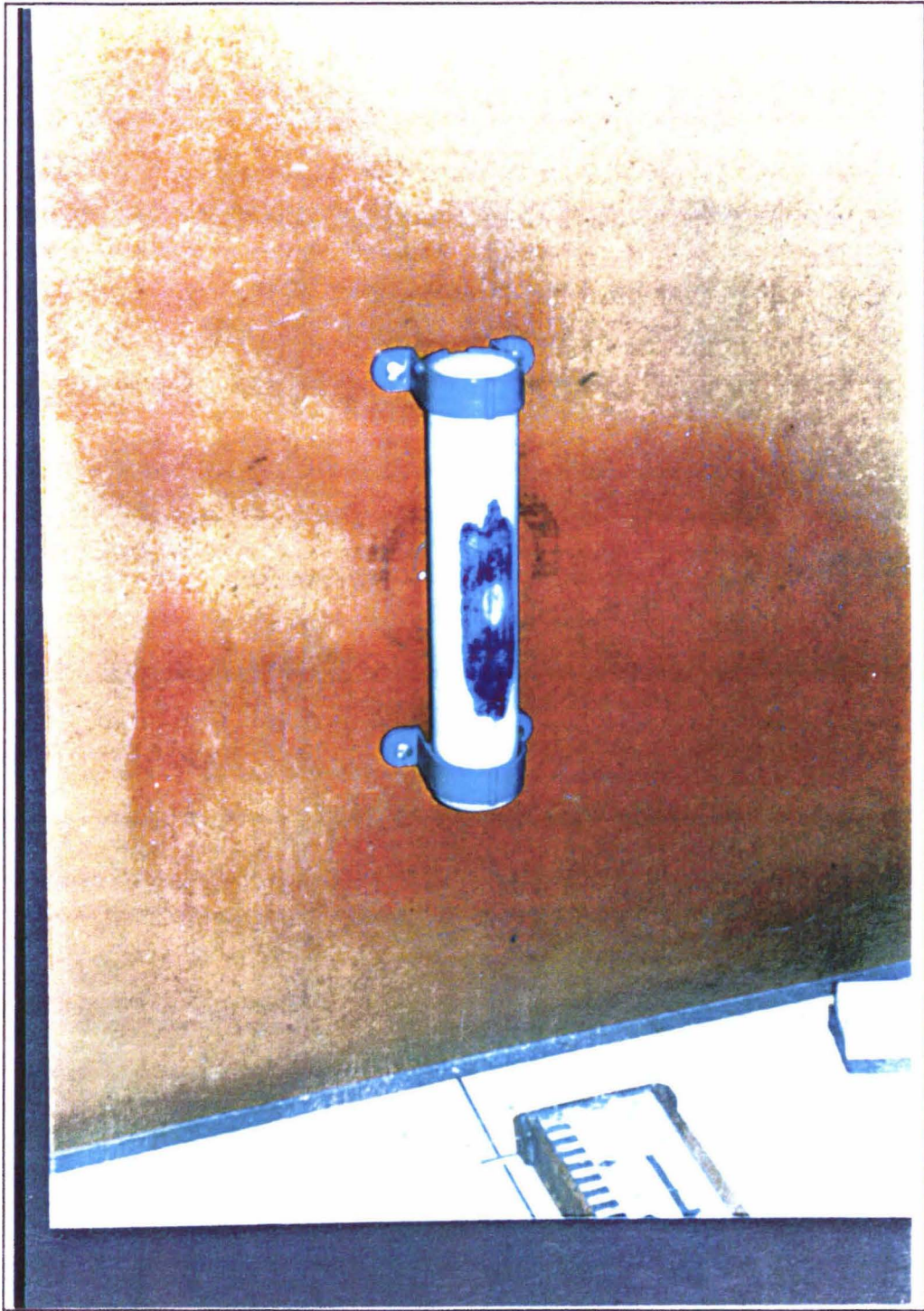

Figure 7.3 The plastic bar fixed onto the impact board

fruit held by hand against a vertical steel block covered with a 6.4 mm thick layer of "Riser" foam (A PVC foam, Product No WM711, manufactured by Nylex New Zealand Ltd, 82 - 84 Victoria St, Petone, New Zealand), 6.4 mm thick Riser foam with a vinyl lining on the surface, and 6.4 mm Riser foam without the vinyl lining. All the materials used were obtained from manufacturers of commercial fruit handling systems.

To produce an impact, an apple was supported by two thin nylon lines using a simple rubber strip holder, and suspended as a pendulum 3.56 metres long as shown in Figure 7.2. The apple was able to move freely in a vertical plane towards a wall. Each apple could be rotated about the calyx-stem axis to give several impact positions. The contact point between the suspended fruit and different impact surfaces was adjusted to give a normal impact in a vertical plane. The suspended apple was swung back and released from different heights against different impact surfaces. After impact the apple was caught by hand to prevent a second impact. The plastic tube and bar were fixed onto the wall in the way shown in Figure 7.3.

Fresh, hand-picked Gala, Splendour, Braeburn, Fuji, and Granny Smith apples were selected at a larger than average size from commercial orchards at the beginning of the harvest period for each variety. The Gala fruit sampled were slightly immature compared to normal harvesting quality. For each impact surface, a sample of 5 apples from each variety was selected at random from fruit collected. A random sample of 15 apples was selected for fruit-to-fruit impacts. All fruit were tested within 24 hours of harvest. The weight of each apple was recorded (Table 7.1) and the impact surface was smeared with ink before the drop tests. The apple was then swung back to the desired height and released. After impact the contact area was measured from the ink mark. The area was generally ellipsoidal, and the major and minor diameters were measured. After measurement the ink was wiped off immediately and each impact area circled using a marker pen. The apple was

then rotated in its holder and the experiment was repeated at a different drop height. Five drop heights (0.6, 2.3, 5.1, 9.1, and 14.3 cm) were used for steel, rubber, plastic bar, plastic tube, and fruit. Drop heights of 14.3, 20.8, 28.7, 38.0, and 49.9 cm were used for 6.4 mm thick Riser foam both with and without a Vinyl lining on the surfaces. Lastly, the IS was dropped five times from each drop height onto the same impact surface, so that twenty-five impacts were obtained from five different drop heights. The procedure was repeated for each impact surface.

Table 7.1.

The average weight and the range of weight used for different varieties

| variety | Average (g) | Range (g) |
|--------------|----------------|---------------|
| Gala | 197.4 | 174.0 - 217.0 |
| Splendour | 201.0 | 176.1 - 237.9 |
| Braeburn | 219.9 | 179.7 - 280.5 |
| Fuji | 249.2 | 214.6 - 288.4 |
| Granny Smith | 222.1 | 199.4 - 242.9 |

For fruit-to-fruit impacts, the results of Chapter 6 were used to analyze the overall bruise thresholds.

7.2.2 Bruise analysis and determination of bruise thresholds

The bruises for all types of impact were allowed to discolour for 24 hours at room temperature before measurements were taken. The apples were first examined for visible bruising, including any flattening, discolouration, or softening. The bruises

were also generally ellipsoidal, and the major and minor diameters were measured. The apple skin in the impact zone was then peeled off, and the major and minor diameters were again measured to determine the bruise area with the skin removed.

Bruise thresholds were obtained by interpolation from the graph of bruise area with

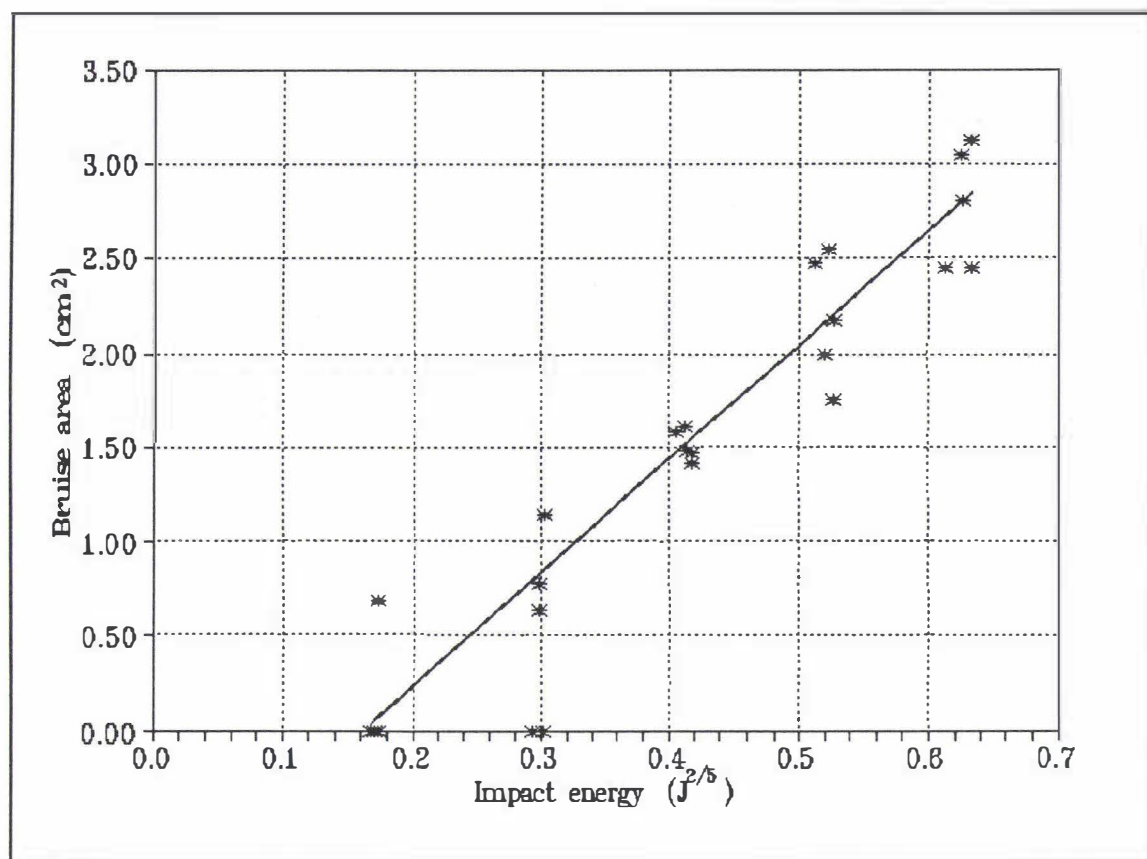

Figure 7.4 Largest bruise area on either apple versus two-fifth power of impact energy for Granny Smith apples in fruit-to-fruit impacts

skin removed against peak acceleration recorded by the IS. The value was taken as the acceleration which caused a 1 cm^2 bruise. This value for each surface tested was then plotted on the IS acceleration-velocity change graph.

7.3 Results

7.3.1 Fruit Tests

No bruising (both with and without skin removal) was found on any fruit dropped from the heights under 21 cm onto 6.4 mm Riser foam both with and without Vinyl lining. This indicated that the 6.4 mm thick layer of Riser foam was soft enough to absorb the impact energy in this range.

For the impacts of fruit against steel and rubber, the bruise area prior to skin removal was hard to detect. However, bruises produced by impacts against both plastic tube and plastic bar were readily visible, and the measured bruise area with skin on was very similar to the area measured when the skin was removed. This was mainly because of the curved edge of the impact surface, which produced a clear edge to the bruised area.

During fruit-to-fruit impact, bruising measured with skin removed was generally more severe on one of the two apples as described in Chapter 4. It was quite common for only one apple to be damaged. The bruise areas of either apples were not correlated with impact energy and the total bruise area of the two fruit were poorly correlated to the impact energy. However, a strong two-fifths power relationship between the largest bruise area and impact energy was found. For example, Figures 7.4 and 6.2 show the relationships for Granny Smith and Splendour apples ($R^2=0.96$) and Table 6.2 gives the relationships for the five different varieties tested. This implied that the largest bruise area was related directly to the impact severity.

7.3.2 Relationship between bruise area and peak acceleration

When the peak acceleration recorded by the IS was plotted against bruise area produced by dropping an apple onto the same surface from the same height, a linear relationship was obtained over the range of impact energy used (e.g. Figure 7.5 and Table 7.3). This result applied to all surfaces and varieties tested. The coefficient of determination ranged from 0.81 to 0.97 (Table 7.3). These regression equations were used to determine the critical acceleration which gave the maximum acceptable bruise area. For this study, this was defined as a 1 cm² bruise with skin removed.

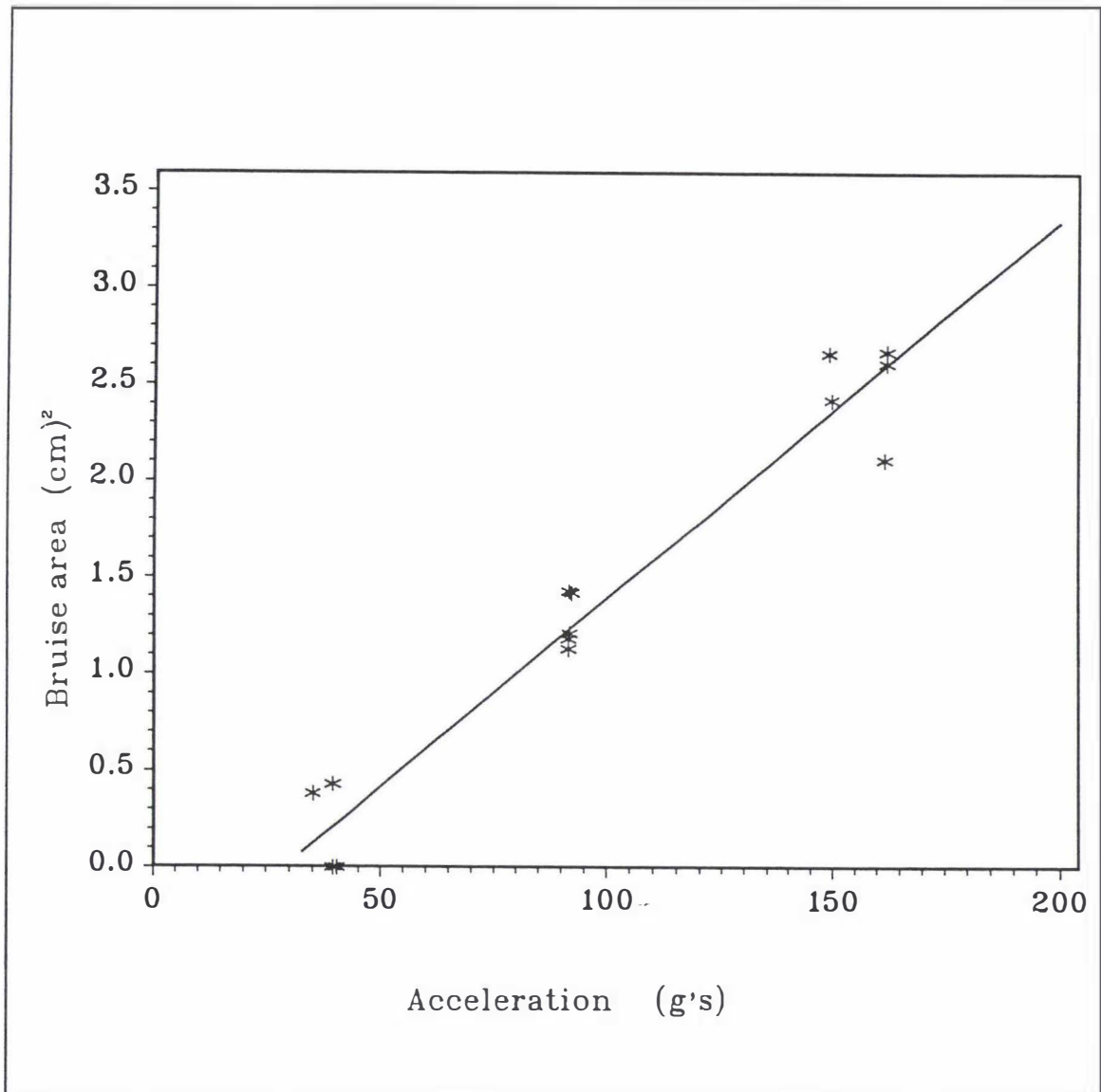

Figure 7.5 Bruise area versus peak acceleration recorded by Instrumented Sphere during impacts of Splendour apples onto a flat steel surface

Table 7.3 Relationship between bruise area and peak acceleration recorded by the Instrumented Sphere. Fruit and Instrumented Sphere were dropped from the same height. Figures in parentheses are Standard Error of each parameter

| | | Variety of apple | | | | |
|--------------------------|---|---|--|--|--|--|
| Impact surface | Splendour | Gala | Fuji | Braeburn | Granny Smith | |
| Steel R ² | A _b = 2.030(0.085)PA-62(±24) 0.97 | A _b = 1.76(0.18) PA-63(±30) 0.81 | A _b = 2.45(0.14)PA-71(43) 0.94 | A _b = 1.73(0.14)PA-57(43) 0.89 | A _b = 2.24(0.13)PA-75(25) 0.93 | |
| Rubber R ² | A _b = 2.04(0.13)PA-35(±38) 0.93 | A _b = 1.805(0.039)PA-60(±42) 0.84 | A _b = 2.38(0.23)PA-49(37) 0.89 | A _b = 2.02(0.14)PA-75(42) 0.92 | A _b = 2.55(0.10)PA-69(17) 0.94 | |
| Tube R ² | A _b = 3.02(0.17)PA-44(±25) 0.95 | A _b = 2.710(0.085)PA-54.3(±17) 0.96 | A _b = 3.61(0.13)PA-49(25) 0.97 | A _b = 2.27(0.15)PA-43(14) 0.95 | A _b = 3.18(0.19)PA-53(17) 0.94 | |
| Bar R ² | A _b = 2.22(0.18)PA-28(±25) 0.90 | -- -- | -- -- | -- -- | -- -- | |
| Fruit R ² | A _b = 5.24(0.55)PA-18(±30) 0.83 | A _b = 5.21(0.38)PA-33.2(±18) 0.92 | A _b = 8.15(0.83)PA-77(45) 0.84 | A _b = 3.93(0.36)PA-30(16) 0.90 | A _b = 6.15(0.66)PA-28(39) 0.83 | |

A_b = Bruise area (mm²)

PA = Peak acceleration (g)

R² = Coefficient of determination

7.3.3 Determination of surface response lines

The surface response lines were determined by plotting velocity change and peak acceleration for each impact pulse. The IS output for each surface is shown in Figure 7.6. The response lines for steel and rubber were almost parallel and quite

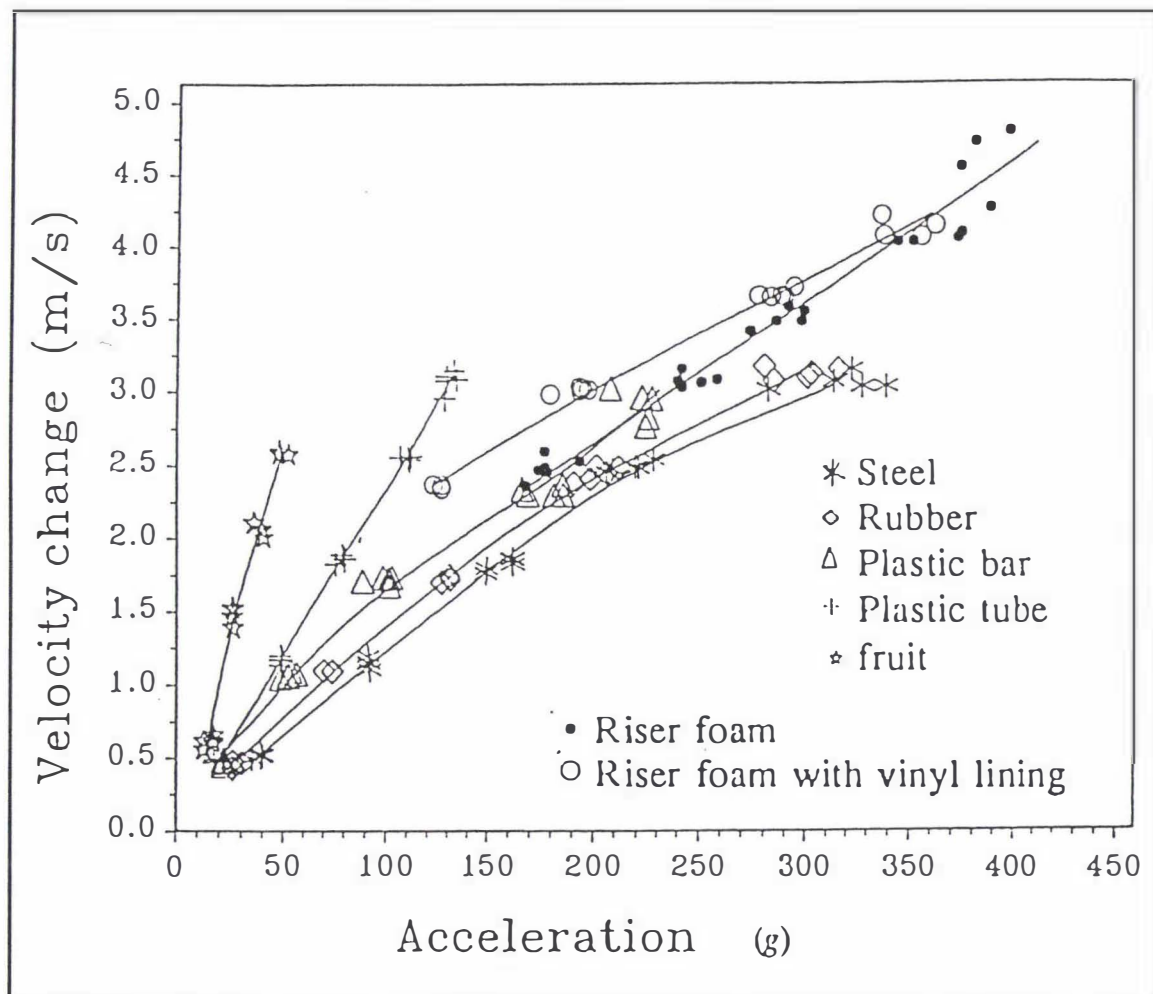

Figure 7.6 Surface response lines for different surfaces tested

close to each other, while the response lines for plastic bar and tube were very different in slope. This meant that the response of the fruit differed between the solid bar and the tube, even though both were 40 mm in diameter. The surface response lines in apple-to-apple impact varied between varieties (Table 7.4).

Table 7.4

The linear relationship between the velocity change and peak acceleration recorded by IS during the impacts of IS onto Gala, Splendour, Braeburn, Fuji, and Granny Smith apples

| Variety | Regression Equation | Coefficient of determination R^2 |
|--------------|---|------------------------------------|
| Gala | $VC = 0.0480 (0.0018)*PA - 0.19 (0.10)$ | 0.97 |
| Splendour | $VC = 0.0576 (0.0038) PA - 0.22 (0.21)$ | 0.93 |
| Braeburn | $VC = 0.054 (0.0027) PA - 0.44 (0.16)$ | 0.96 |
| Fuji | $VC = 0.0503 (0.0026) PA - 0.11 (0.14)$ | 0.95 |
| Granny Smith | $VC = 0.0540 (0.0027) PA - 0.09 (0.16)$ | 0.96 |

VC = Velocity change (m/s),

PA = Peak acceleration (g)

* = Standard error of each parameter is given in parentheses

7.3.4 Potential bruise boundary

The bruise thresholds for each variety of apple for all impact surfaces (except 6.4 mm Riser foam with or without the vinyl lining) are shown in Figures 7.7 to 7.11. These diagrams can be separated into two regions representing areas of bruising ($> 1 \text{ cm}^2$) and no bruising ($< 1 \text{ cm}^2$). The area above and to the left of the response line for fruit-to-fruit impacts, and to the right and beneath the response line for steel surfaces, were areas where impacts were unlikely to be recorded, and so the boundary has been completed by drawing vertical and horizontal lines in these areas.

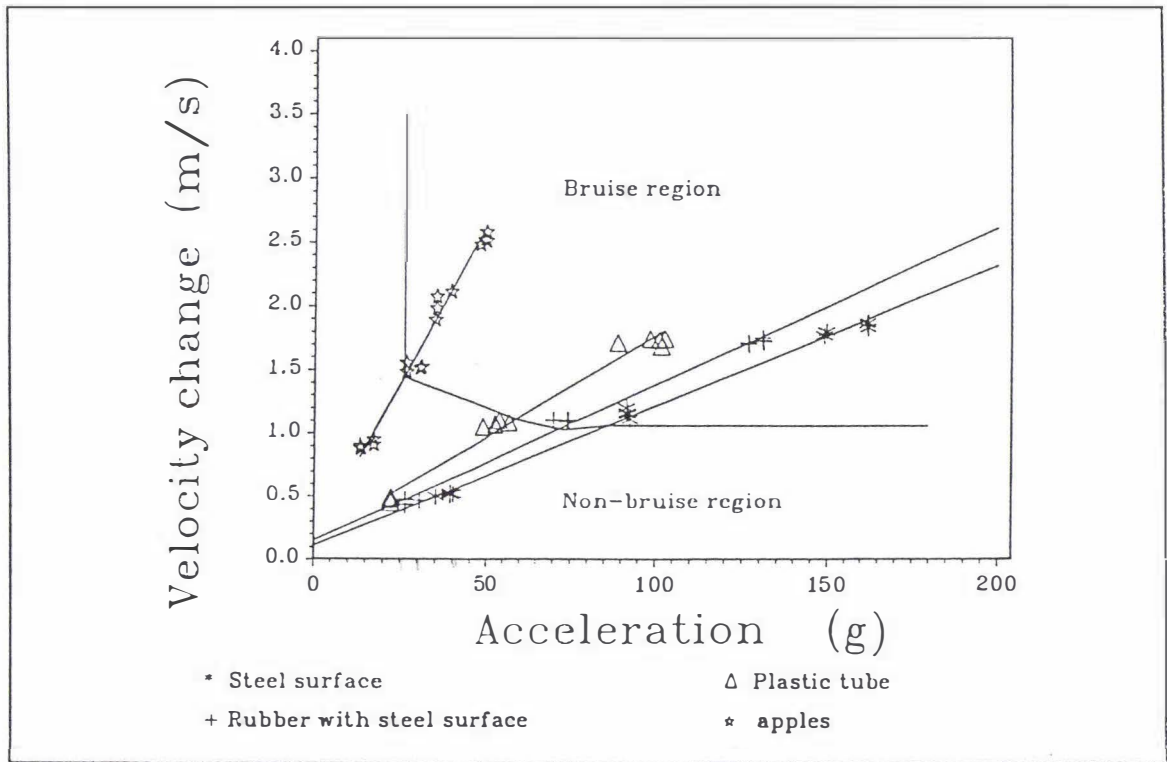

Figure 7.7 Bruise boundary for Gala apples

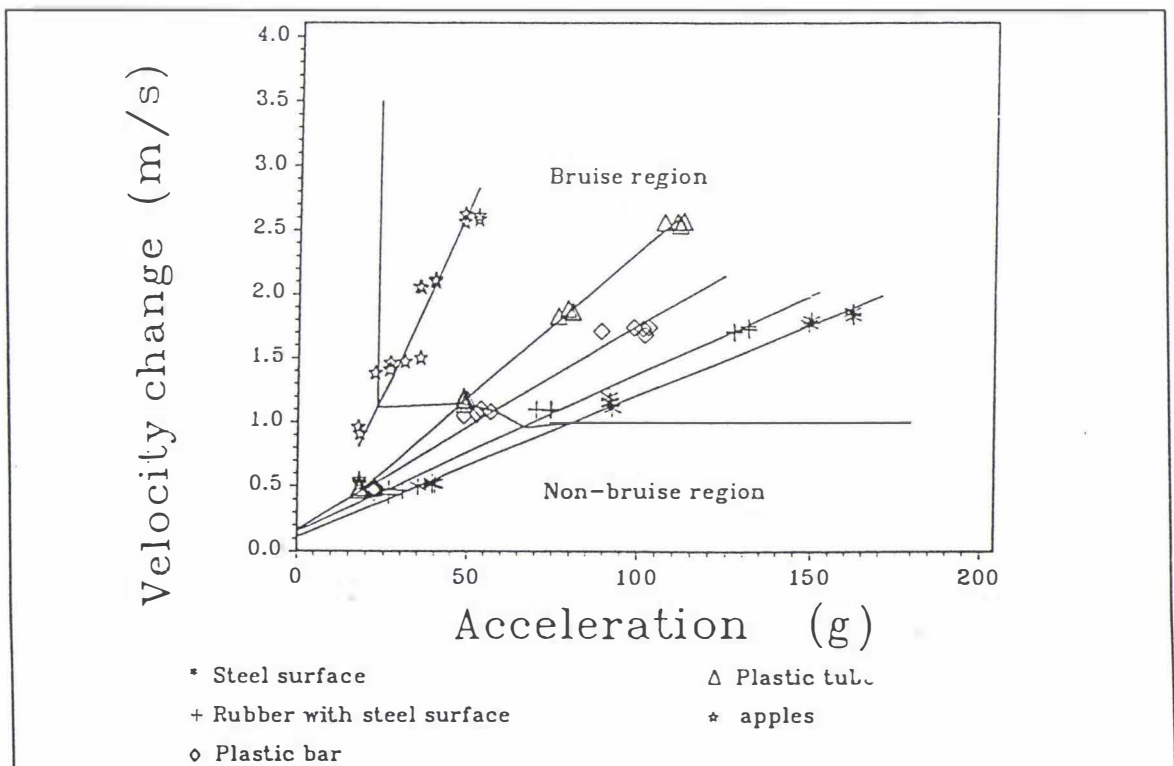

Figure 7.8 Bruise boundary for Splendour apples

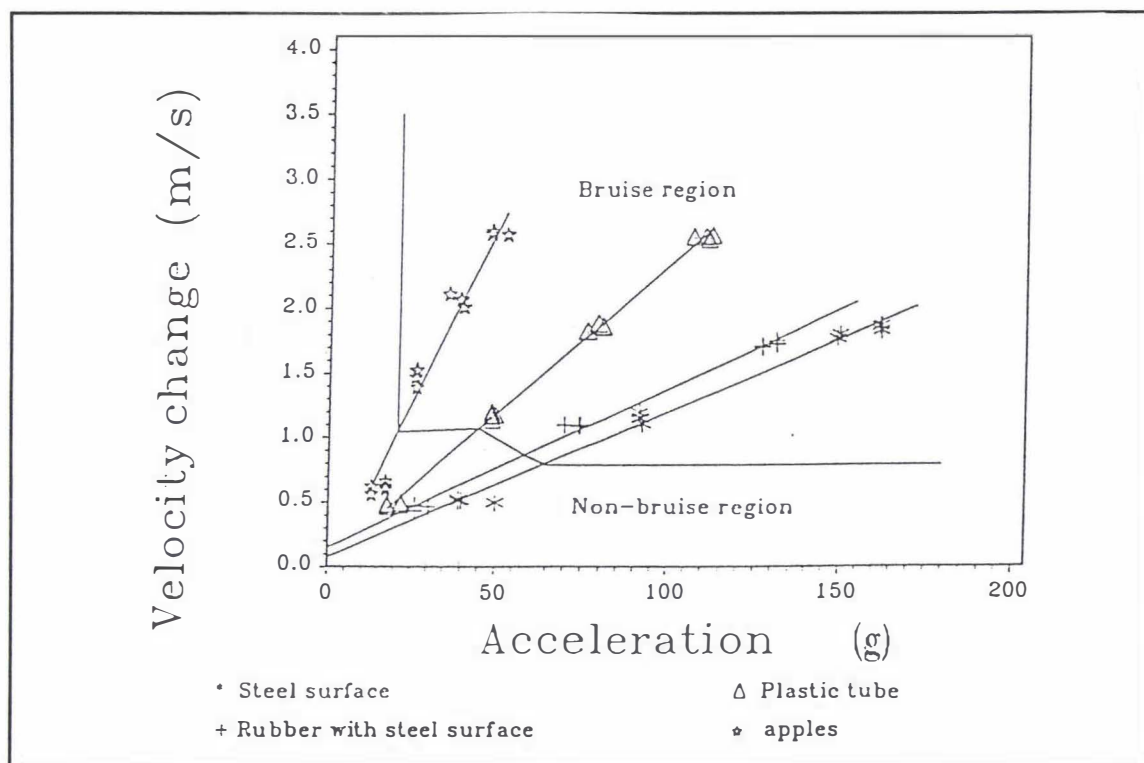

Figure 7.9 Bruise boundary for Granny Smith apples

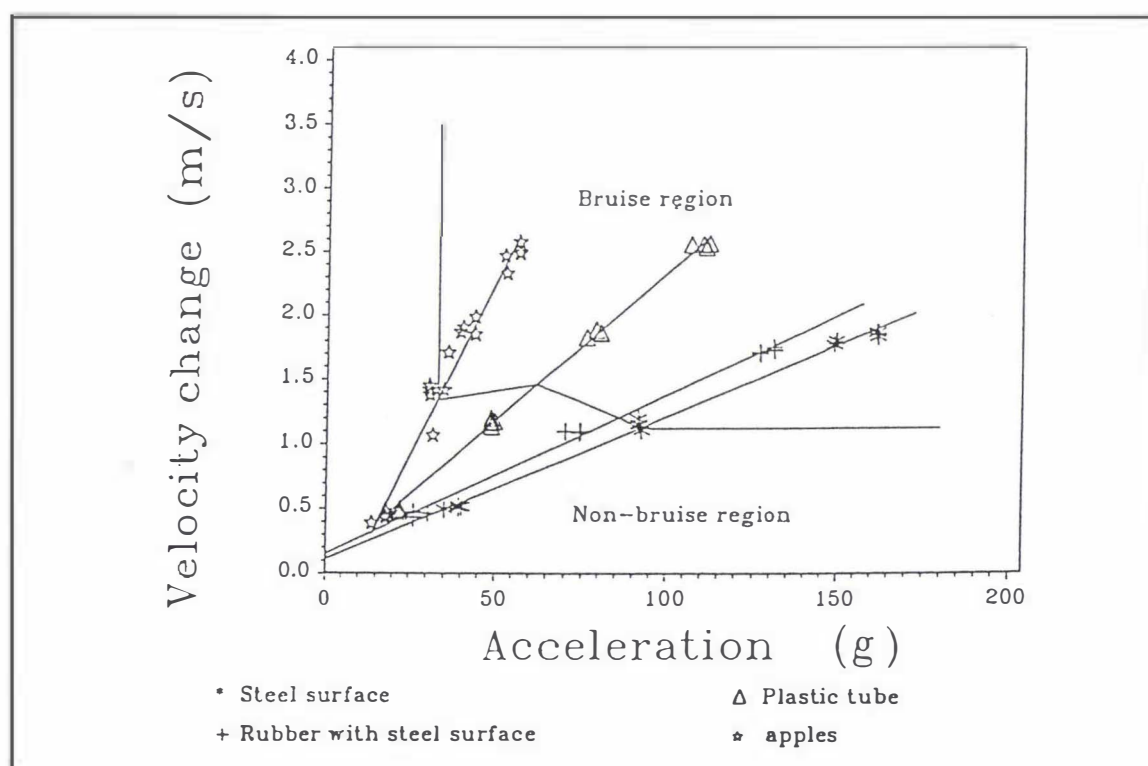

Figure 7.10 Bruise boundary for Braeburn apples

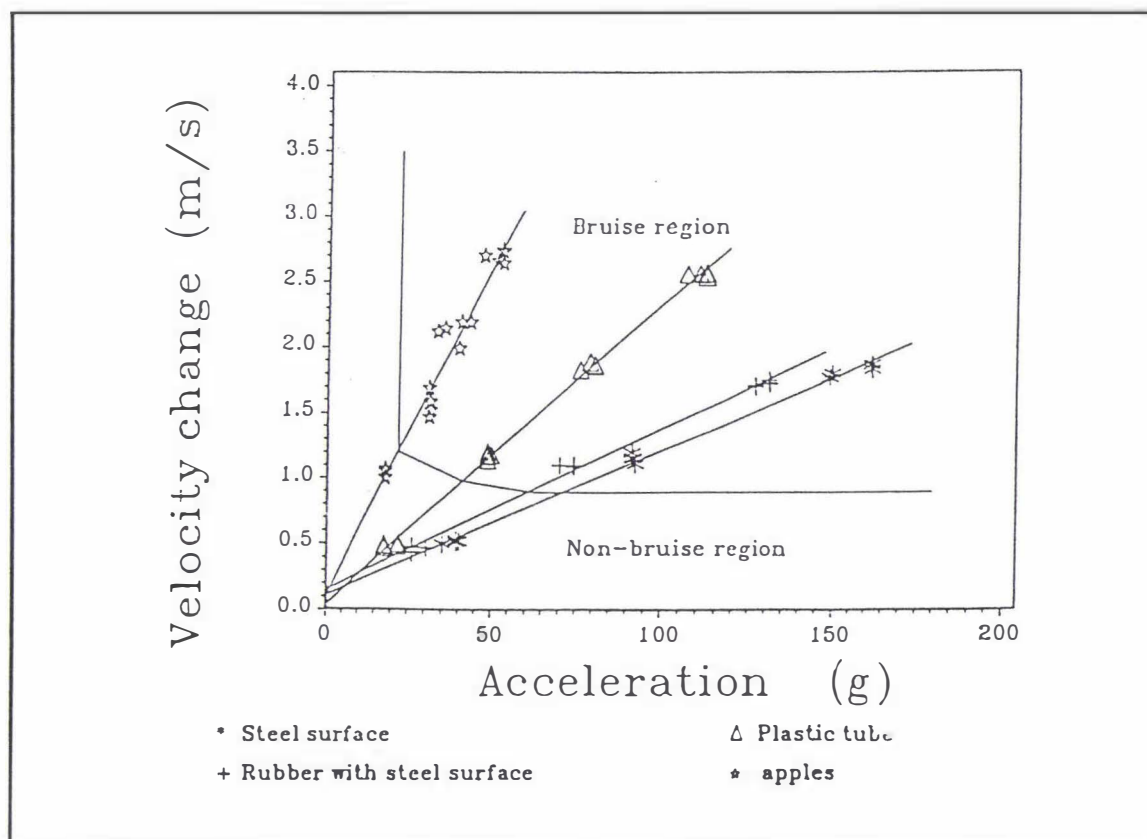

Figure 7.11 Bruise boundary for Fuji apples

7.4 Discussion

Following the argument of Schulte-Pason et al. (1990), measured impacts onto any surface possessing the combination of velocity change and peak acceleration which fall within the bruise region are likely to produce unacceptable bruising to the fruit. However, over the range of drop heights up to 14.3 cm, no bruising was found on any varieties of fruit impacted onto 6.4 mm Riser foam with or without the Vinyl lining. This indicated that these surfaces would be able to prevent bruise damage to fruit for these drop heights. Other work has shown that impacts on surfaces padded with 6 mm thick riser foam can cause IS readings of 190 g's and velocity changes of 2.4 m/s without producing bruising (Bollen and Dela Rue, 1991). The

IS outputs for 6.4 mm Riser foam (with and without vinyl lining) are shown in Figure 7.6. The potential bruise boundary for a 1 cm² bruise was not calculated for the padded surfaces. Bruising was only observed on these surfaces if the acceleration recorded by the IS was 179 g's or higher for the most easily bruised varieties (Splendour and Granny Smith).

The shape of the bruise threshold curves described in the literature (Bollen and Dela Rue, 1990; Schulte-Pason et al., 1990) give weight to impacts onto flat padded surfaces, with considerable cushioning. Field results (Banks, 1991) and the current study, indicate that impacts against cushioned surfaces are not major causes of bruising, while fruit regularly strike hard curved surfaces, or other fruit, which can cause damage. It is therefore argued that considerably more emphasis should be placed on fruit-to-fruit impacts and impacts of fruit onto surfaces which are harder than the fruit, and threshold values should be related to these impacts. However, it was also noted that over time padding materials could become hardened due to wear and ingrained dirt. Thus tests on new samples of padding materials may not give a true picture of performance in practice.

It may be argued that the criterion for bruising is somewhat harder than would be expected by the industry for two reasons. Firstly, the use of a 1 cm² bruise after skin removal is a harsher requirement than the same area without skin removal, since in the latter case the bruise may not be visible, or it may appear to be smaller. These are valid arguments. However, it is necessary to point out that the resulting bruise certainly exists, even if it is not visible, and has been introduced by the handling system. The consumer may also find the fruit quality less than satisfactory, particularly if fruit is peeled prior to consumption: bruised areas cause conventional hand peelers to stick and "dig in" to the flesh, making any bruises readily apparent.

Secondly, this analysis does not make an allowance for the probability of a bruise actually occurring. The analysis determines the recorded acceleration which would, on average, produce a 1 cm² bruise - if a bruise is produced at all. In this case it is argued that it is the level at which equipment has the potential to cause damage in a particular variety which is significant, rather than the number of occasions when damage actually results.

From the above comments it is clear that these thresholds will generally be conservative estimates. Frequently a fruit receiving an impact around the level of the bruise threshold will appear to be undamaged, and would pass current grading criteria. However, against this it should be noted that grading criteria generally relate to the total bruise area, rather than the size of a single bruise. Thus a small number of sub-critical bruises can still result in a sub-standard fruit. Thus a conservative bruising threshold for individual impacts is preferable for the assessment of grading and handling systems.

When bruise boundaries for the varieties were plotted together, clear differences emerged (Figure 7.12). Braeburn apples were the most bruise resistant, followed by Gala. However, the samples used to obtain the Gala potential bruise boundary were slightly immature when harvested, and consequently the potential bruise boundary for Gala should be treated with caution. On the other hand, the potential bruise boundary for Braeburn apples was significantly different to other varieties. A greater IS acceleration reading would be required to produce a critical bruise area in this variety. The bruise areas on Braeburn apples were also found to be significantly lower for a given impact energy (Table 7.2): Braeburn apples were more resistant to bruising than the other varieties. The bruise boundaries determined in this study differed between varieties, but all had the same general shape. In order to provide potential bruise boundary information which can be used in practical situations, it is suggested that the boundary for the most sensitive

apple variety likely to be processed by the equipment under test should be used.

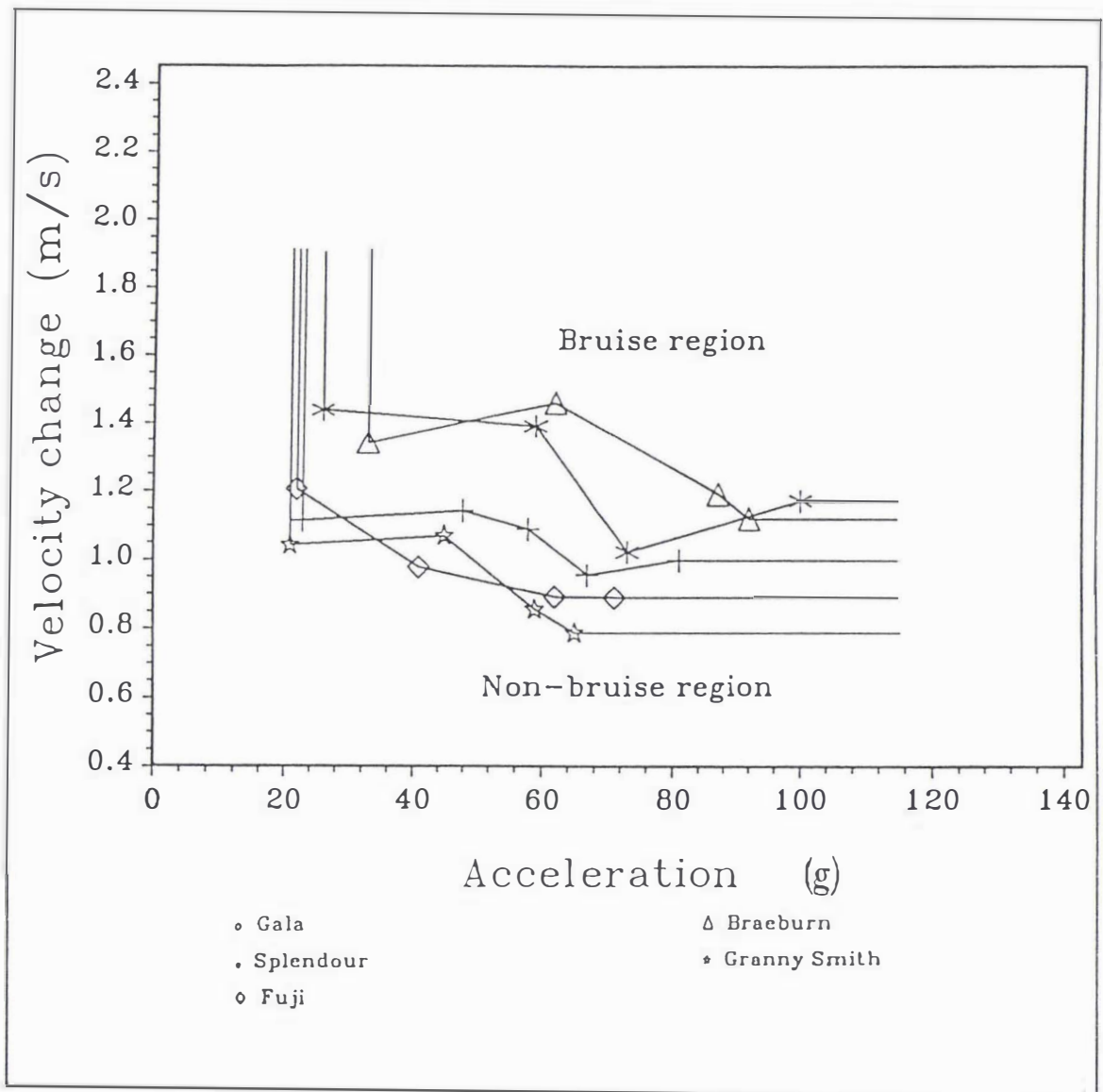

Figure 7.12 Bruise boundaries for different varieties tested

7.5 Conclusions

In this study, impacts against non-flat surfaces and apple-to-apple impacts have been studied. A bruise threshold has been determined for each surface for five varieties of apple, and a potential bruise boundary has been developed for each variety. It is argued that this boundary is more reliable for predicting bruise potential of impacts recorded by the Instrumented Sphere (IS) on commercial packing lines than previously reported bruise threshold curves based on flat cushioned surfaces.

Impact tests have been conducted on freshly picked Gala, Splendour, Fuji, Braeburn, and Granny Smith apples, all grown in Hawke's Bay, New Zealand. Bruise areas produced during impact onto flat steel, rubber, plastic tubing, and a solid plastic bar were found to be linearly correlated with the peak acceleration recorded by an IS dropped from the same height over the range from 0.6 cm up to 14.3 cm. During fruit-to-fruit impacts, the area of the larger of the two bruises was also linearly related to peak acceleration recorded when the IS was dropped onto another fruit from the same height.

For each variety and each surface the drop height required to produce a critical bruise with a surface area of 1 cm^2 (as measured with the skin removed) was determined. By correlating IS output with bruise area on each surface, a threshold potential bruise boundary was produced on a velocity change against acceleration graph. The boundary curve, which included apple-to-apple impact, was hyperbolic in shape, rather than the linear boundary described in other studies. These differences are discussed and accounted for by differences in the nature of the impact surfaces used. It is argued that this new boundary is a more reliable indicator of handling equipment performance, in view of the importance of apple-to-apple impacts.

8. CHANGES IN APPLE BRUISE SUSCEPTIBILITY WITH IMPACT CONDITIONS AND STORAGE

8.1 Introduction

The last 3 chapters have focused on the estimate of bruising produced by commercial grading equipment. The discussion in chapter 7 highlighted the problems of deciding what criteria to use to define bruising (e.g. area with skin on, area with skin removal, or bruise volume). This chapter therefore considers the bruising phenomenon itself, and how bruise susceptibility may be assessed.

As discussed in chapter 2, a wide range of tests have been used, with conflicting results. Hyde and Ingle (1968) reported that increasing the period between harvest and bruising decreased the bruise size. Schoorl and Holt (1977) stated that the resistance Jonathan, Delicious and Granny Smith apples to bruising decreased with increasing storage time (the bruise size increased markedly with the increasing storage time at 1.25 J impact energy absorbed). In contrast, Holt and Schoorl (1984) again reported that no correlation existed between impact bruise resistance (defined as the volume of bruised tissue per unit of energy absorbed) and storage time up to 20 weeks. The impact tests were carried out at drop heights of 0.5 m. Klein (1987) concluded that susceptibility of apples to impact damage, bruise weight or bruise volume (averaged over 10 and 40 cm drop height) increased from early to late harvest time and decreased during storage.

The purposes of this Chapter were therefore to determine bruise susceptibilities of different fruit cultivars at low impact energies at different storage times, and to examine the relationship between bruise volume, energy absorbed, and bruise area.

8.2 MATERIALS AND METHODS

Trial 1 (1990)

The experiment described in Chapter 5 was repeated on stored Granny Smith apples for further investigation of bruise susceptibility in free apple-to-apple impacts. Granny Smith apples grown in Hawke's Bay were carefully hand picked and placed into standard cartons at harvesting time. A sample of thirty apples were selected at random for experiment 1. The rest were placed in a conventional cold storage at 0-1 °C.

Thirty apples were sorted at random into pairs, and their weights were recorded individually. Two apples were hung at the ends of two pendulums with their calyx-stem axes horizontal, so that they just touched when hanging freely. One of them was then swung back by hand and released from a series of angles, rotating both fruit to a new impact position each time. The angles used were 55, 40, 30, 20, 15, 10 and 5 degrees for first five pairs of apples: 50, 35, 25, 18, 12, 8 and 6 degrees for the second five pairs of apples, 55, 45, 25, 11, 9, 7, and 4 degrees for the third five pairs of apples. Before dropping, one apple was smeared with ink in the impact position each time, so that after impact the second apple was left with a mark from which the contact area was determined. The major and minor diameters of the contact area were measured. The rebound angles of the two apples were recorded by video camera, and the apples were caught to prevent a second impact each time. Thus there were seven marked areas around the cheek of each apple. Bruise volumes and areas were measured as outlined in Chapter 5, after allowing the bruises to develop over 24 hours.

Fourteen days later, a second set of thirty apples were selected from cold storage,

allowed to warm to room temperature, and the experiment was repeated. The same procedure was followed after 44 days storage. Finally, ten apples were selected randomly after 220 days and the experiment was repeated, but using only the first five drop heights.

Trial 2 (1991)

Data from experiments on different cultivars discussed in Chapter 7 were used to assess bruise susceptibility of fresh fruit. In addition, samples of Splendour apples were tested after 100 and 160 days storage. In all cases apples were allowed to reach room temperature before the experiment was carried out.

8.3 Results

Trial 1

There was a strong linear correlation between the total bruise volume of the two apples and energy absorbed at all storage times (in Table 8.1, the coefficient of determination ranged from 0.93 to 0.96). The total bruise volume was plotted against energy absorbed during the impacts as shown in Figures 8.1-8.4. The slope of the regression line was used as a measure of bruise susceptibility (cm^3/J).

For comparison of the bruise susceptibility of Granny Smith apples at different storage times, the statistical analysis showed that the 4 regression lines were significantly different ($P < 0.01$). Bruise susceptibility decreased with time in storage up to 44 days, but increased after 220 days (Figure 8.5).

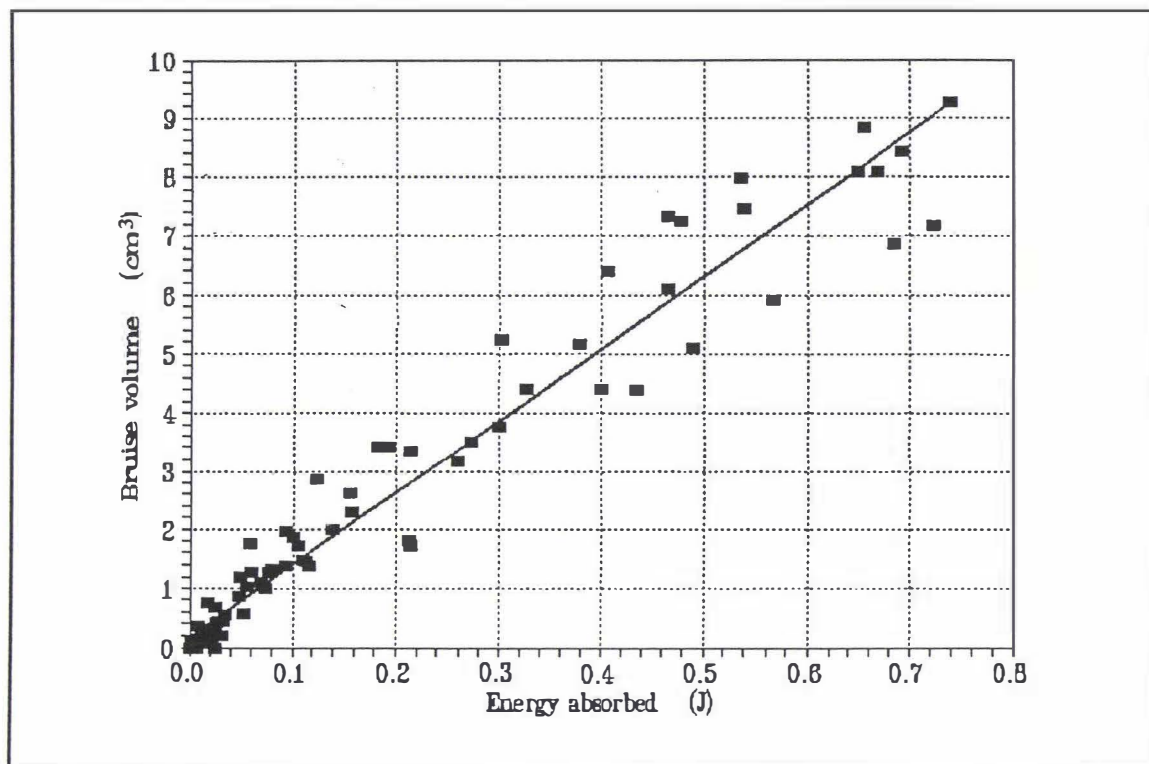

Figure 8.1 The linear relationship between total bruise volume of the two fruit and energy absorbed during apple-to-apple impacts for fresh Granny Smith in the 1990 season

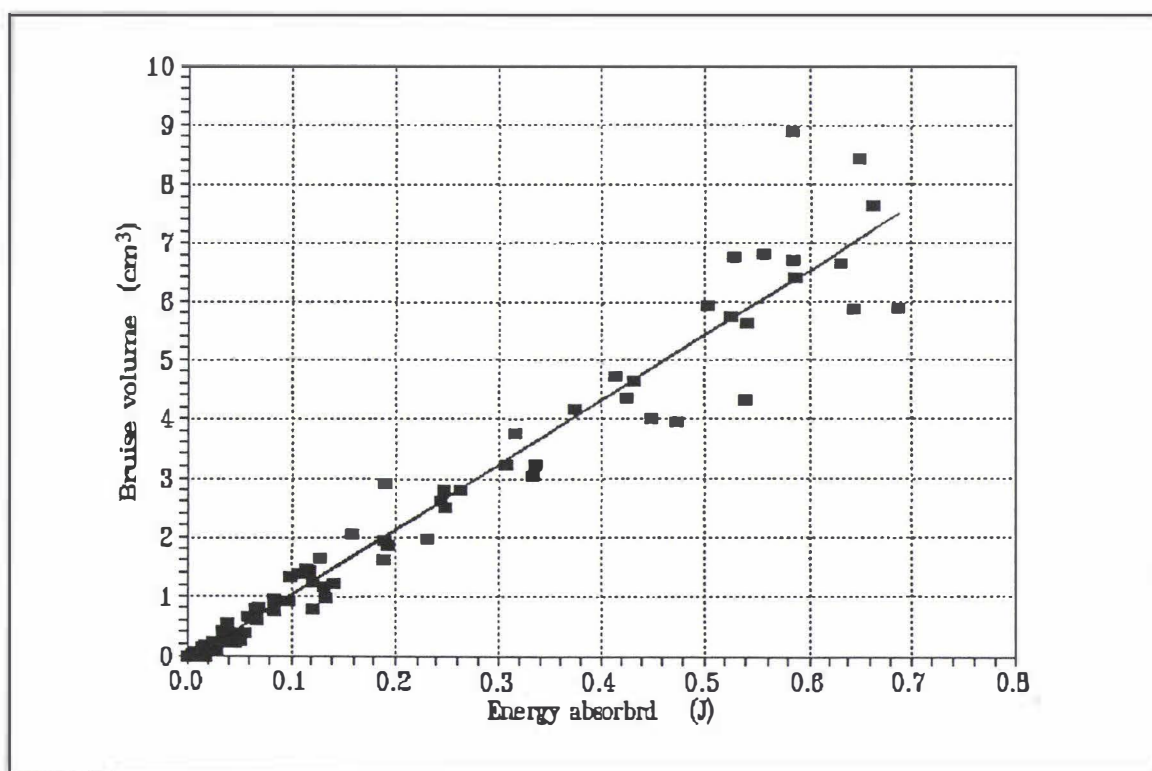

Figure 8.2 The linear relationship between total bruise volume of the two fruit and energy absorbed during apple-to-apple impacts for Granny Smith apples after 14 days storage

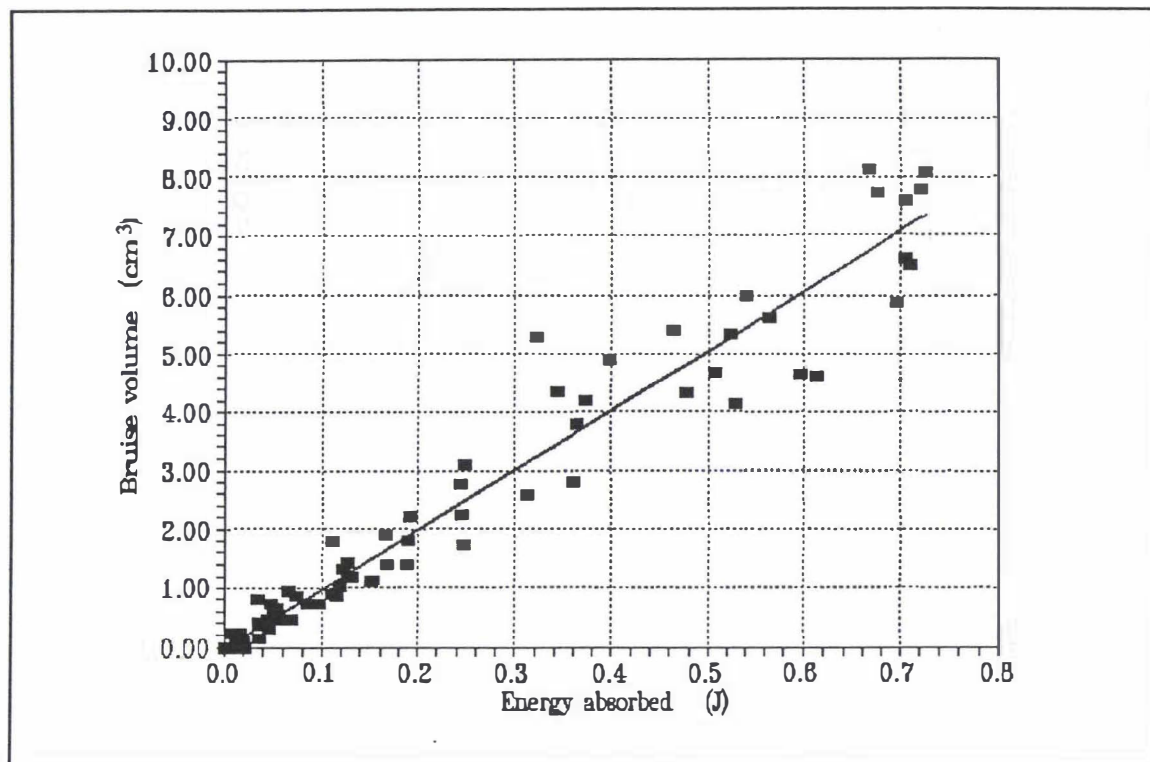

Figure 8.3 The linear relationship between total bruise volume of the two fruit and energy absorbed during apple-to-apple impacts for Granny Smith apples after 44 days storage

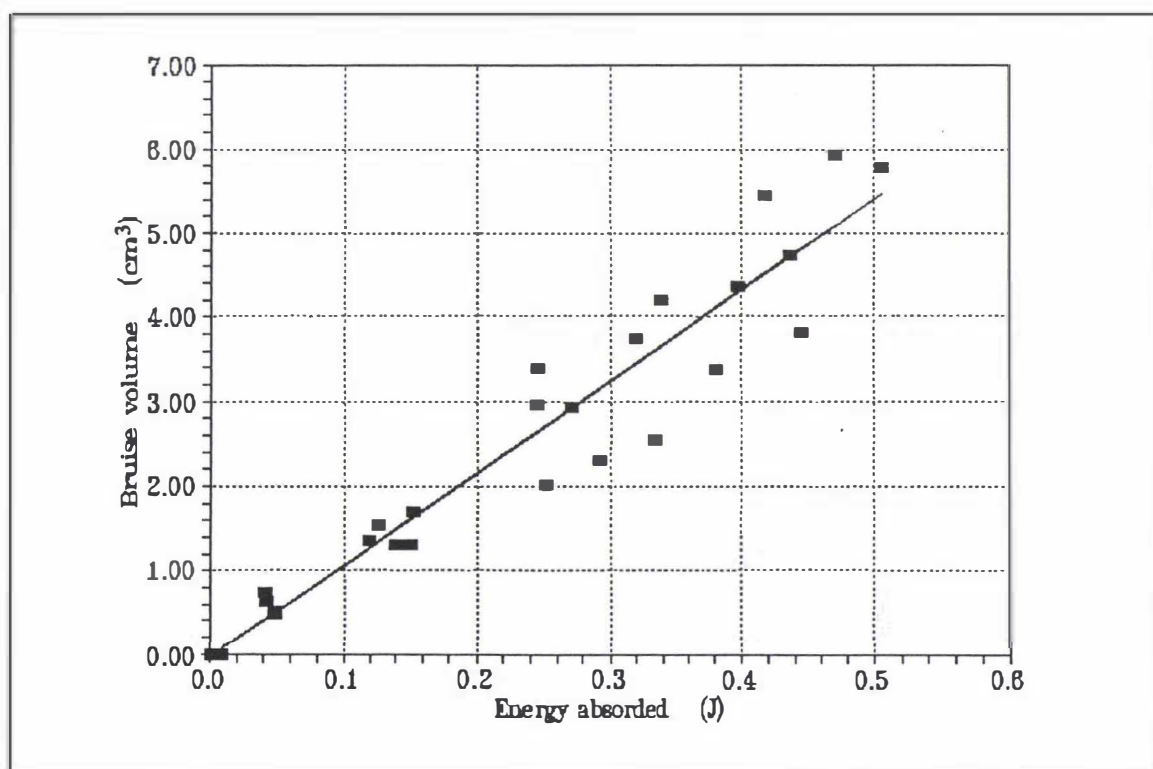

Figure 8.4 The linear relationship between total bruise volume of the two fruit and energy absorbed during apple-to-apple impacts for Granny Smith apples after 220 days storage

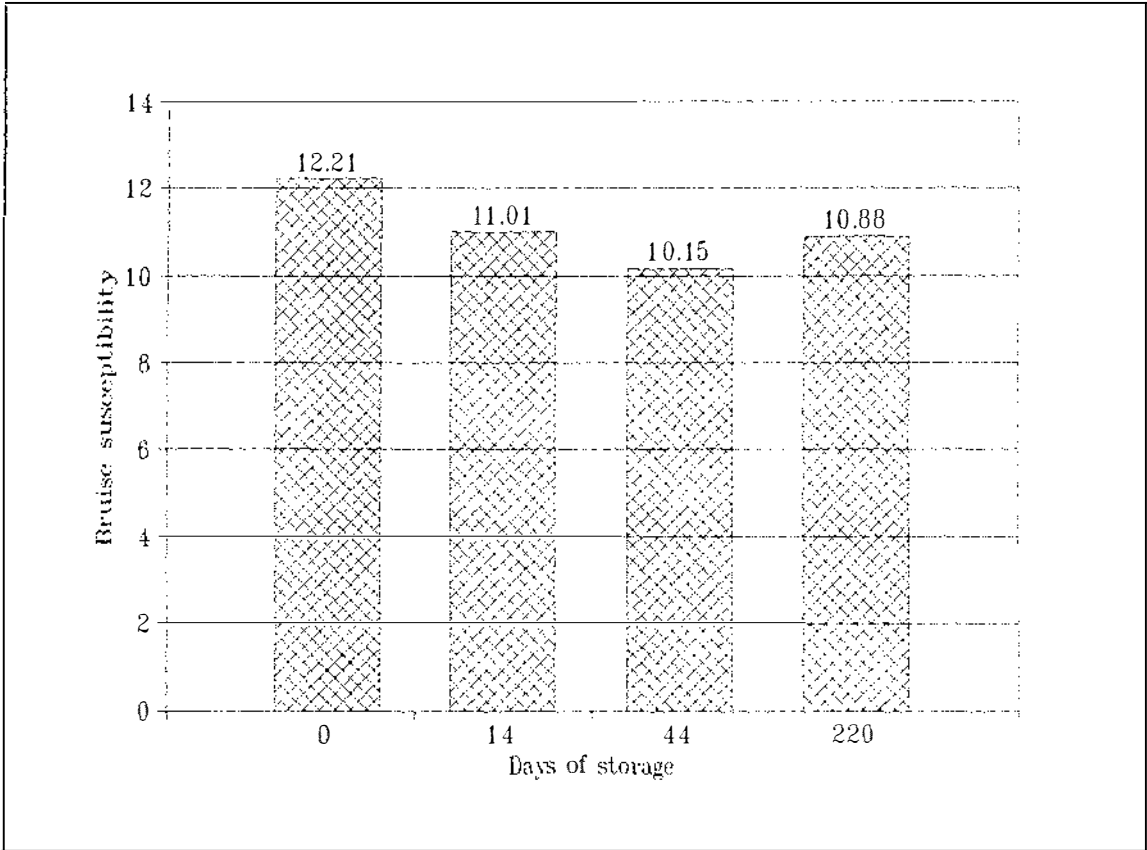

Figure 8.5 Bruise susceptibility (cm³/J) of Granny Smith apples at different storage times

Table 8.1. Relationship between total bruise volume and energy absorbed for Granny Smith apples after different storage time in the 1990 season.

| days | Regression Equation | Coefficient of determination (R^2) |
|------|--|--|
| 0 | $V_b = 12.21 (0.27)E_a + 0.15 (0.56)$ | 0.96 |
| 14 | $V_b = 11.01 (0.22) E_a - 0.08 (0.48)$ | 0.96 |
| 44 | $V_b = 10.15 (0.21) E_a - 0.04 (0.48)$ | 0.96 |
| 220 | $V_b = 10.88 (0.56) E_a - 0.03 (0.50)$ | 0.93 |

V_b = bruise volume (cm^3)

E_a = energy absorbed (joule)

Trial 2

Statistical analysis showed that there was a strong linear relationship between bruise area and $2/5$ power of impact energy for all impact surfaces (R^2 ranged from 0.89 to 0.99). During the impact of fruit-to-fruit, the bruise area on neither the dropped nor the stationary apple was related to the impact energy. However, the largest bruise area of the two fruit was directly proportional to the $2/5$ power of impact energy (Table 8.2). The slope of the regression line for bruise area against $2/5$ power of impact energy could therefore be taken as an alternative measure of bruise susceptibility ($\text{cm}^2/\text{J}^{2/5}$), on an area rather than a volume basis.

Table 8.2. Relationship between bruise area and $2/5$ power of impact energy for fresh apples

| Type of impact | Variety | Regression equation | Coefficient determination R^2 |
|----------------|--------------|--|---------------------------------|
| Steel | Braeburn | $A_b = 9.27 (\pm 0.24) K - 1.71 (\pm 0.19)$ | 0.97 |
| | Granny Smith | $A_b = 10.26 (\pm 0.40) K - 1.63 (\pm 0.32)$ | 0.97 |
| | Splendour | $A_b = 10.80 (\pm 0.41) K - 1.69 (\pm 0.31)$ | 0.97 |
| | Fuji | $A_b = 11.64 (\pm 0.47) K - 1.92 (\pm 0.40)$ | 0.96 |
| Rubber | Braeburn | $A_b = 11.60 (\pm 0.68) K - 3.04 (\pm 0.38)$ | 0.94 |
| | Granny Smith | $A_b = 11.30 (\pm 0.36) K - 2.03 (\pm 0.29)$ | 0.98 |
| | Splendour | $A_b = 10.90 (\pm 0.38) K - 1.82 (\pm 0.29)$ | 0.97 |
| | Fuji | $A_b = 10.60 (\pm 0.45) K - 2.03 (\pm 0.38)$ | 0.96 |
| Tube | Braeburn | $A_b = 5.73 (\pm 0.18) K - 0.94 (\pm 0.14)$ | 0.98 |
| | Granny Smith | $A_b = 7.32 (\pm 0.17) K - 1.14 (\pm 0.14)$ | 0.99 |
| | Splendour | $A_b = 8.30 (\pm 0.27) K - 1.34 (\pm 0.21)$ | 0.98 |
| | Fuji | $A_b = 8.41 (\pm 0.31) K - 1.21 (\pm 0.26)$ | 0.97 |
| Fruit | Braeburn | $A_b = 3.31 (\pm 0.15) K - 0.30 (\pm 0.13)$ | 0.89 |
| | Granny Smith | $A_b = 6.02 (\pm 0.43) K - 0.97 (\pm 0.34)$ | 0.95 |
| | Splendour | $A_b = 5.53 (\pm 0.24) K - 0.88 (\pm 0.18)$ | 0.96 |
| | Fuji | $A_b = 7.31 (\pm 0.39) K - 1.46 (\pm 0.33)$ | 0.94 |

A_b = Bruise area (cm^2)

K = $2/5$ power of impact energy ($\text{J}^{2/5}$)

The regression lines for Splendour, Granny Smith, and Fuji were not significantly different ($P > 0.01$); only the regression line for Braeburn was slightly different from others.

The ratio of the larger bruise area of the two fruit to $2/5$ of impact energy was also determined as shown in Figure 8.6. These were not significantly different for an same kind of impact surface ($P > 0.01$).

The ratio of bruise area to $2/5$ power of impact energy measured from fruit-to-fruit impacts varied considerably (Figure 8.7). The statistical analysis, however, showed

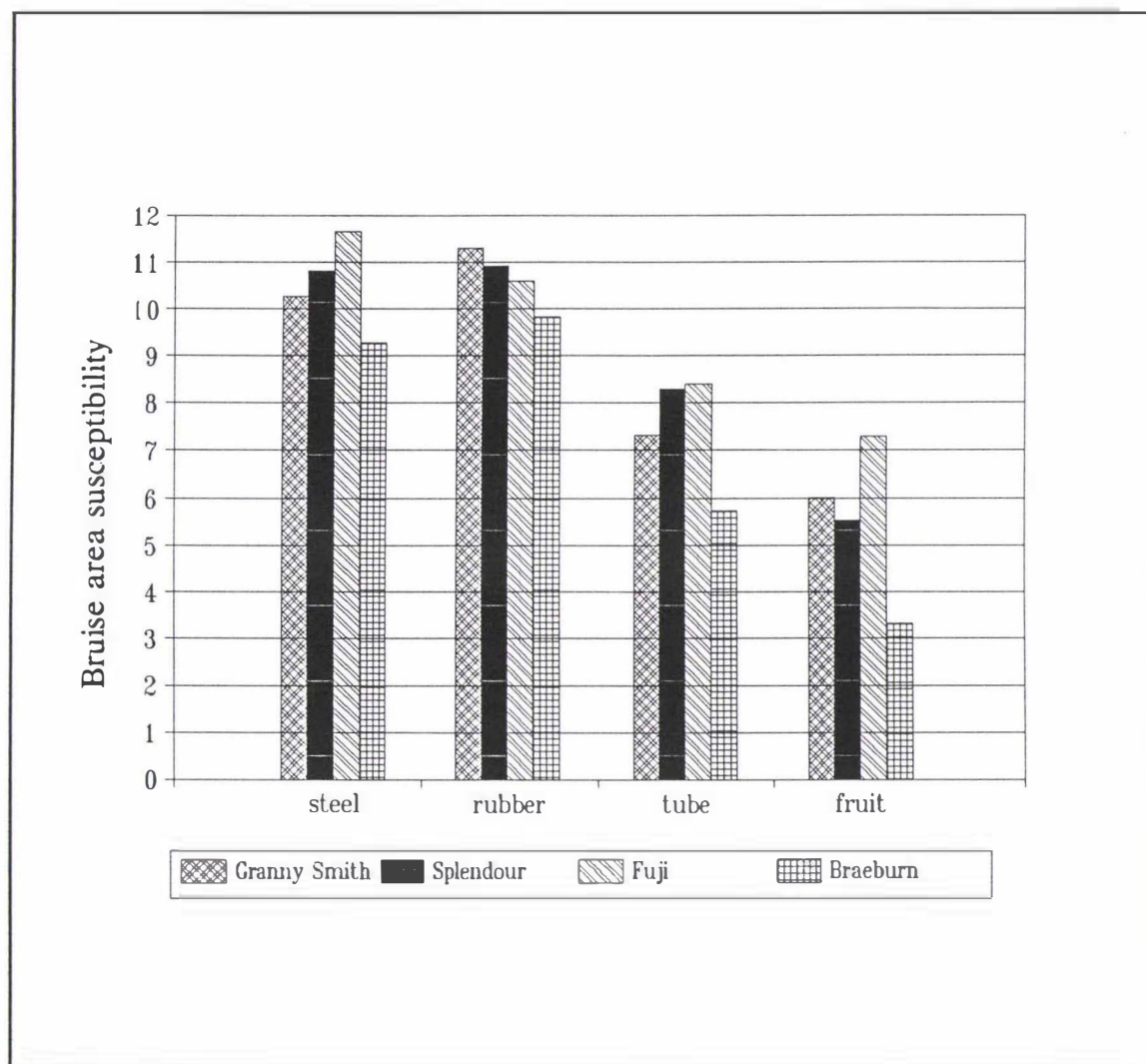

Figure 8.6 The ratio of the larger bruise area of the two fruit to $2/5$ power of impact energy ($\text{cm}^2/\text{J}^{2/5}$) during the impacts of Granny Smith, Splendour, Fuji, and Braeburn onto different surfaces in the 1991 season

that the slopes for Granny Smith, Splendour, and Fuji were not significantly different during the impacts onto the same surface ($P > 0.01$). Braeburn was again slightly different from the other four varieties on all impact surfaces. This indicated that the physical properties of Braeburn fruit were significantly different.

For all varieties of fruit, the ratios of bruise area to $2/5$ power of impact energy ($\text{cm}^2/\text{J}^{2/5}$) were affected by the impact surfaces. The values for fruit-to-fruit and fruit-to-tube were remarkably lower than steel or rubber surfaces (Figure 8.6).

The effect of storage was determined by repeating the whole procedure at three and five months of storage for Splendour apples. The linear relationship between bruise area and $2/5$ power of impact energy are listed in Table 8.3. The ratios for fruit-to-steel and fruit-to-fruit impacts are shown in Figure 8.8, indicating the values for steel surface decreased slightly, but those for fruit-to-fruit impact were not statistically affected by storage time ($P > 0.01$).

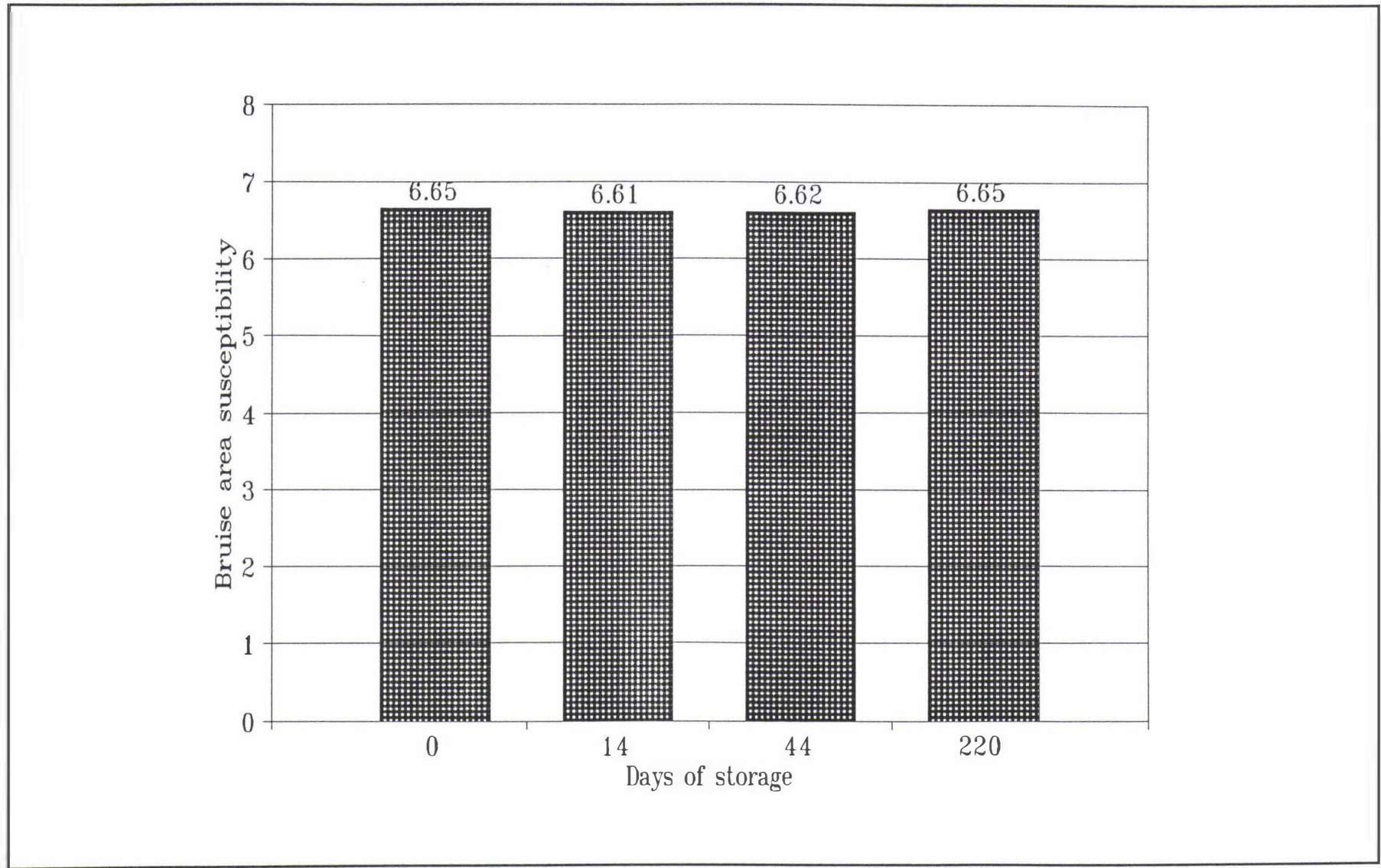

Figure 8.7 The ratio of bruise area to $2/5$ power of impact energy for Granny Smith apples at different times in storage

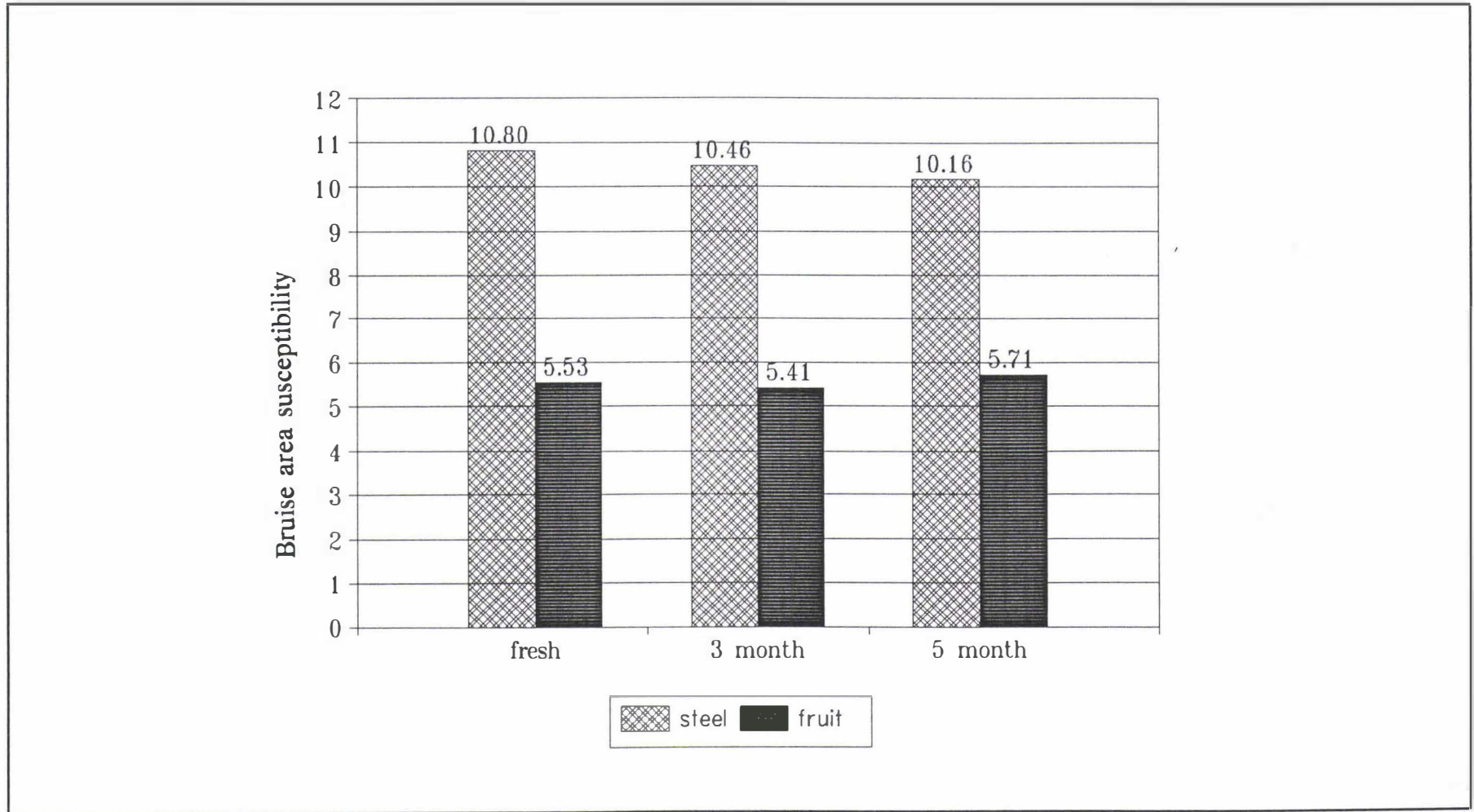

Figure 8.8 The ratio of bruise area to $2/5$ power of impact energy ($\text{cm}^2/\text{J}^{2/5}$) of Splendour during the impacts of fruit-to-steel and fruit-to-fruit at different times in storage in the 1991 season

Table 8.3.

Relationship between bruise area and $2/5$ power of impact energy during the impacts of fruit-to-steel and fruit-to-fruit for Splendour apples at different times in storage.

| Month | Steel | R^2 | Fruit | R^2 |
|-------|--|-------|---|-------|
| | Regression equation | | Regression equation | |
| 0 | $A_b = 10.80(\pm 0.41)E - 1.69(\pm 0.31)$ | 0.97 | $A_b = 5.53 (\pm 0.24) E - 0.88 (\pm 0.18)$ | 0.96 |
| 3 | $A_b = 10.46(\pm 0.36) E - 1.52(\pm 0.26)$ | 0.97 | $A_b = 5.41 (\pm 0.25) E - 1.25 (\pm 0.19)$ | 0.77 |
| 5 | $A_b = 10.16(\pm 0.40) E - 1.52(\pm 0.31)$ | 0.97 | $A_b = 5.71(\pm 0.36) E - 1.10(\pm 0.28)$ | 0.92 |

8.4 Discussion

While Holt and Schoorl (1977) used the ratio of the bruise volume to the energy absorbed in the impact of fruit onto a flat hard surface as a measure of bruise susceptibility (mL/J), the ratio of bruise area to the impact energy could be much easier to obtain in practical situations. The bruise area on the fruit surface has also been used as a criteria of fruit bruising by the fruit industry. In this study, the ratio of bruise volume to energy absorbed and the larger bruise area of the two fruit to $2/5$ power of impact energy were used in Trial 1. The linear relationship between the larger bruise area of the two fruit and $2/5$ power of impact energy in both trials of 1990 and 1991 agreed with the results of Pang et al. (1991b).

There is evidence that the mechanical strength of apple tissue deteriorates with storage time (Holt and Schoorl, 1984), and it may be expected that fruit bruise susceptibility for different varieties should also be different. Hyde and Ingle (1968)

found that bruise size decreased with longer storage times by dropping a spherical object with 0.16 J of impact energy. Schoorl and Holt (1977) also reported that bruise resistance decreased with increasing storage time, by using energy levels from 0.35 J to 2.0 J.

From the results of both trials in 1990 and 1991, it can be seen that for Granny Smith apples bruise susceptibility (cm^3/J), the ratio of bruise volume to energy absorbed, decreased with increasing time in storage (Figure 8.5), which agreed with the results of Klein (1987) and Hyde and Ingle (1968), but in contrast with the results of Schoorl and Holt (1977). The ratio of bruise area to $2/5$ power of impact energy did not give any significant difference for different times in storage for both Splendour and Granny Smith. This suggests that the bruise area under impact could be used to derive an alternative measure of bruising, but it may not give a reliable parameter for indicating the bruise area susceptibility of fruit. Further study is needed to establish the usefulness of this parameter and the damage sensibility of fruit.

8.5 CONCLUSIONS

1. Bruise susceptibility of Granny Smith apples varied with storage time, falling with time from $12.2 \text{ cm}^3/\text{J}$ when fresh to $10.2 \text{ cm}^3/\text{J}$ after 44 days storage. After 220 days storage bruise susceptibility increased to $10.9 \text{ cm}^3/\text{J}$.
2. The ratio of bruise area to $2/5$ power of energy for Granny Smith did not vary during storage.
3. The ratio of bruise area to $2/5$ power of energy for four cultivars on four different surfaces have been determined.

9. A NEW APPROACH TO ASSESS APPLE BRUISING

9.1 Introduction

In general, there are three ways to assess apple bruising: bruise area both with and without skin removal, bruise volume, and the number of bruises. Bruise area and bruise volume have been used by previous researchers and quality controllers. Measurements include major and minor diameters of the bruise region both with and without skin removal, and the depth of bruise. Bruise area or bruise volume can be calculated from these measurements. Bruise susceptibility is obtained by taking the ratio of bruise volume to the impact energy absorbed during the impact at a given energy level, or by taking the slope of the regression line over a range of energy levels (Schoorl and Holt, 1977).

As discussed in Chapter 3, the study of bruises produced by a mechanical fruit grader showed that the absolute bruise area may not be a reliable measure of bruising. In this chapter, the total number of visible bruises on fruit produced by a typical mechanical fruit grader was used as a standard measure of bruising and was compared with a range of tests used to assess fruit physical properties.

9.2 Methods of determining fruit firmness and maturity

The commonly used device for estimating fruit firmness is the Magness-Taylor pressure tester, which has been used for over 60 years (Bourne, 1965). The reading obtained from this instrument is the maximum force applied to a tip as it penetrates into fruit with skin removed. Although there is considerable doubt as to whether it has any use for indicating bruise susceptibility, the pressure tester is still used

widely in the fruit industry as a measure of fruit firmness.

Standard Brix and starch tests have been used to give general information about the sugar and starch content of fruit. The starch test is used commercially by the New Zealand Apple and Pear Marketing Board for the determination of fruit maturity at harvest.

Following the principle of Schoorl and Holt (1977), a ball dropping test has been developed and used (Banks, 1992) for determining fruit bruise susceptibility. As shown in Figure 9.1, a steel ball 30 mm in diameter and 0.110 kg in mass is dropped from a height of 0.275 m, giving an impact energy of 0.3 J.

In view of the importance of bruise problems during handling processes, the designing of harvesting, sorting, grading, and packaging equipment has been given considerable attention in order to reduce impacts. Generally, providing it is maintained and fruit loading density and rod speed remain the same, a piece of equipment will produce the same level of impacts on fruit each time it is used. Thus, if it is desired to study the effects of temperature or seasonal or variety differences on bruise susceptibility, a given handling procedure can be considered as a constant "bruise generator". Differences in bruise susceptibility between fruit from different treatments or varieties should be clearly indicated by the amount of bruising produced by the "bruise generator". Unfortunately such an approach would require large quantities of fruit, and the assessment would be very slow. However, using such a handling procedure as a standard, bruise susceptibility obtained by other tests could be directly compared. Following an approach taken by Mowatt and Banks (1992), a commercial grader was used as the standard, and a series of experiments were conducted to compare bruising measures. In addition, a new "bruise factor" test was developed as a rapid means of assessing bruise susceptibility.

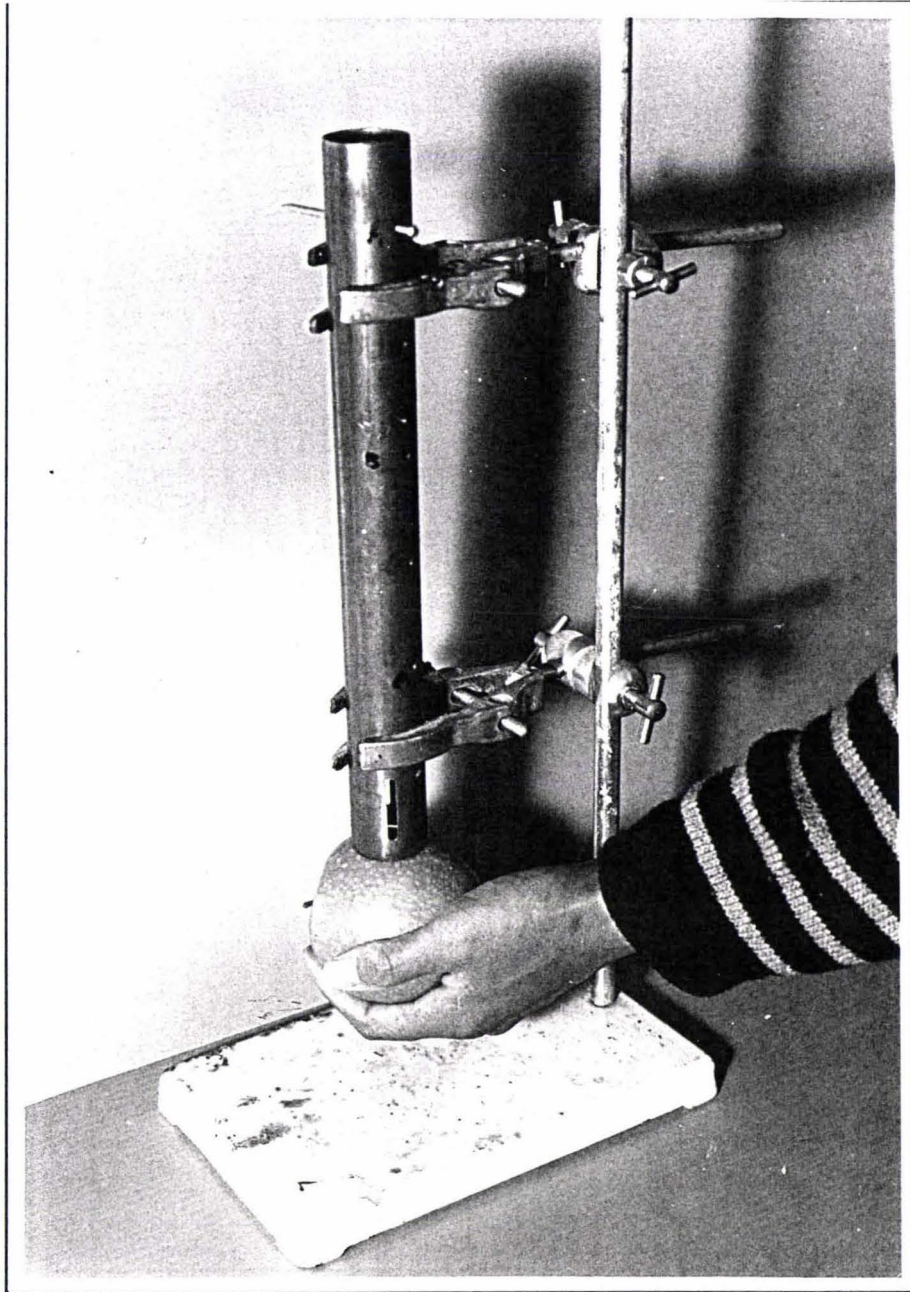

Figure 9.1 Ball drop test

9.3 Materials and methods

9.3.1 Experimental apparatus

(a) Fruit grading machine

A fruit grader was used in this Chapter as a standard bruise generator as described in Chapter 3. Fruit were carefully placed by hand onto the sorting table in two pairs of lines, each pair close to an edge of the sorting table, so that each pair of lines fed into one cup lane of the two lane grader. After all the fruit had passed through the grader the machine was stopped, and the procedure was repeated four times for each test.

(b) Laboratory impact rig

The equipment consisted of a single aluminum pendulum 750 mm long with a mass of 0.101 kg. The pendulum was mounted on a roller bearing, and hung in front of a large background sheet which could be adjusted horizontally (Figure 9.2). A series of grooves 10 mm apart were cut into the pendulum to hold the fruit in place on the rod. A heavy steel block (about 5 kg) with a flat end surface was attached to the board, so that fruit mounted at the centre of percussion of the pendulum would strike the block at normal incidence. The centre of percussion was selected as the impact point. If the impact acts upon on the pendulum arm through the centre of percussion, the impulsive force at the centre of rotation will be equal to zero, so that no energy will be absorbed at the hinge during an impact.

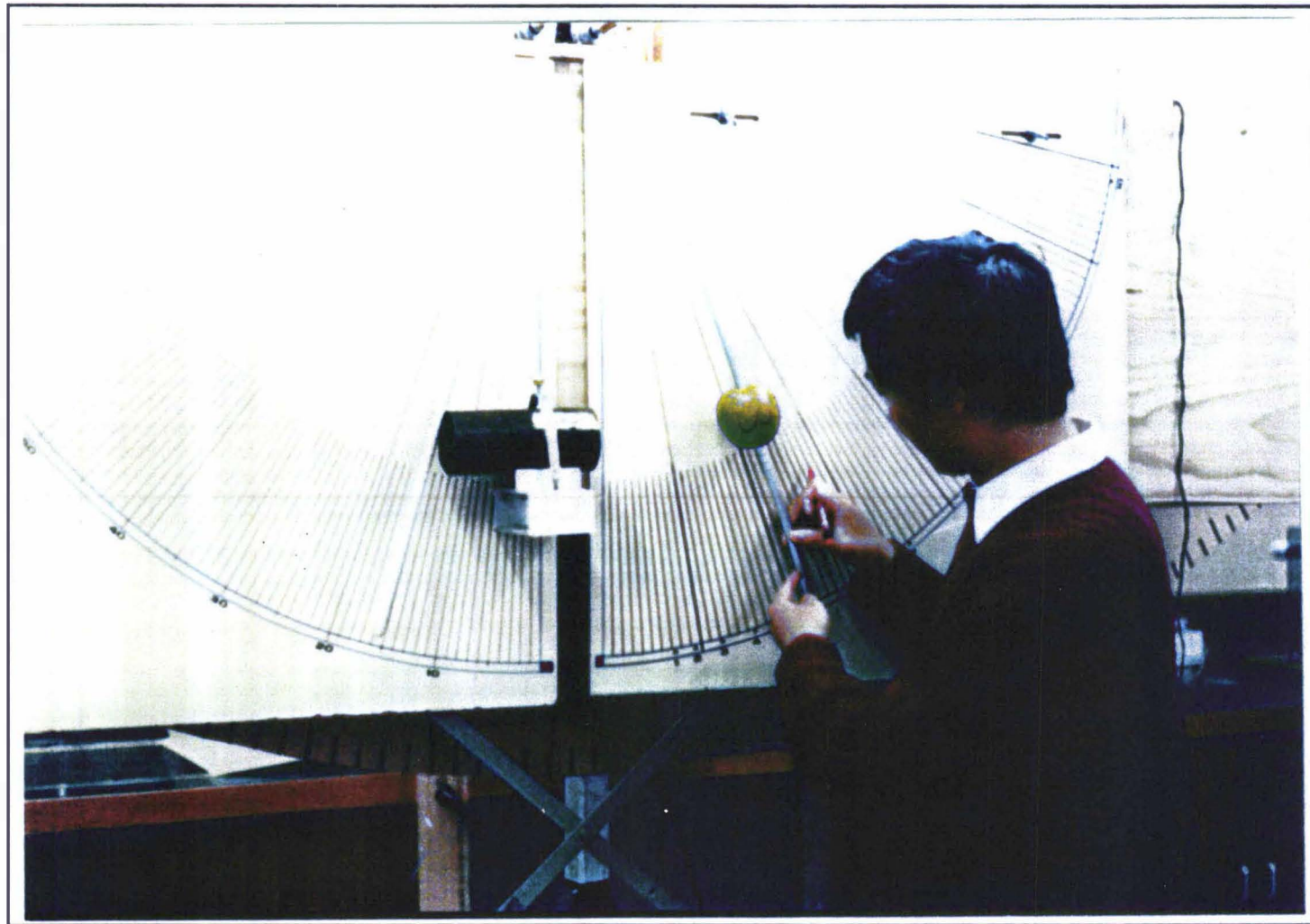

Figure 9.2 The pendulum device designed for determining Bruise Factors

A simplified illustration of the pendulum system is shown in Figure 9.3. In this case, the aluminium arm with even mass distribution can be considered to be a rigid rotating body with a fixed axis at O . Therefore, the moment of inertia of the pendulum arm about the pivot point O is given by:

$$I = \sum m_i r_i^2 = \int_0^l \frac{m_p}{l} r_i^2 dr_i \quad \dots\dots\dots(9.1)$$

Integrating,

$$I = \frac{1}{3} m_p l^2 \quad \dots\dots\dots(9.2)$$

where

I = moment of inertia (kg m^2),

m_i = mass of a small length of rod dr_i long (kg)(Figure 9.3),

r_i = distance from the particle to rotating point O (m),

m_p = mass of aluminium arm (kg),

l = length of the arm (m).

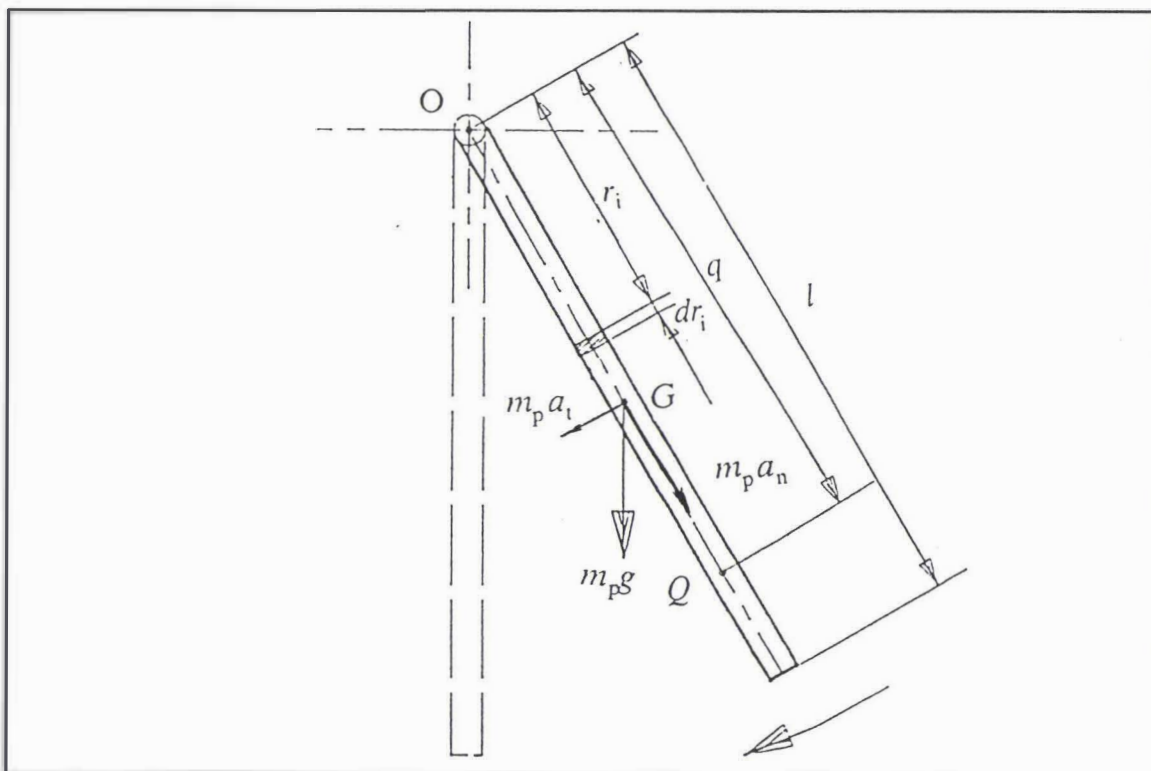

Figure 9.3 Simplified pendulum system

If the angular acceleration and angular velocity are α_a and ω respectively, the acceleration of the mass centre G has normal and tangential components $a_n = r \omega^2$ and $a_t = r \alpha_a$. The tangential force component $m_p r \alpha_a$ can be moved to a parallel position through a point Q at distance q from the point of rotation O in line with G and O as shown in Figure 9.3 . Thus Newton's law for rotation can be written:-

$$m_p r \alpha_a q = I \alpha_a \quad \dots\dots\dots(9.3)$$

Where

$$r = \frac{l}{2} \qquad I = \frac{1}{3} m_p l^2$$

and cancelling $m_p \alpha_a$ from equation 9.3, gives

$$q = \frac{2}{3} l \quad \dots\dots\dots(9.4)$$

The distance q from the centre of rotation (point O) determines the centre of percussion on the arm.

(c) Determination of drop heights

Once the distance from the pivot to the impact point was given, it was easy to calculate dropping angles from the drop heights. The range of drop heights was carefully considered in this study. Ideally, the range of drop heights should represent the range of impact levels in the grader. The heights (h , mm) were determined by a geometrical progression of heights given by:

$$h = k_p q_p^{n-1}$$

where $n = 1$ to 10 , k_p and q_p were 4.00 mm and 1.668 respectively. The initial drop height k_p was determined based on the results of Chapter 4, which should not cause

bruising for New Zealand fresh apples. The geometric progression factor 1.668 was determined in order that the range of drop heights was closely related to those on the grader. Thus the range from 4 mm to 400 mm was used with ten different drop heights.

9.3.2 Fruit preparation and Bruise Factor test

(a) Fruit samples

The Gala fruit used in this experiment were obtained and stored under the same conditions as described in Chapter 3. One hundred and twenty Gala apples were randomly selected from cartons brought back from the Hawke's Bay orchard and tested at room temperature within 24 hours of harvest. The rest of the sample was put into a commercial cool-store at 0.5 °C for further use. After 7 days, a second 120 apples were tested inside the cool-store at 0.5 °C. After 14 days, a further 120 fruit were taken out of the cool-store and allowed to reach room temperature before the test. The tests were then carried out at 20 °C.

Freshly picked Fuji, Granny Smith and Braeburn apples were collected from field bins during the harvest period. The tests were carried out in the same day at 20 °C. Samples of Granny Smith apples were also collected at different harvest dates (in one week interval) to examine the effects of fruit maturity.

(b) Bruise Factor test

Twenty fresh Gala apples were randomly selected from the samples of fruit brought back from Hawke's Bay. Each had a hole drilled through its centre in line with the flower to stalk axis by a cork borer, 10 mm in diameter, as shown in Figure 9.4. A

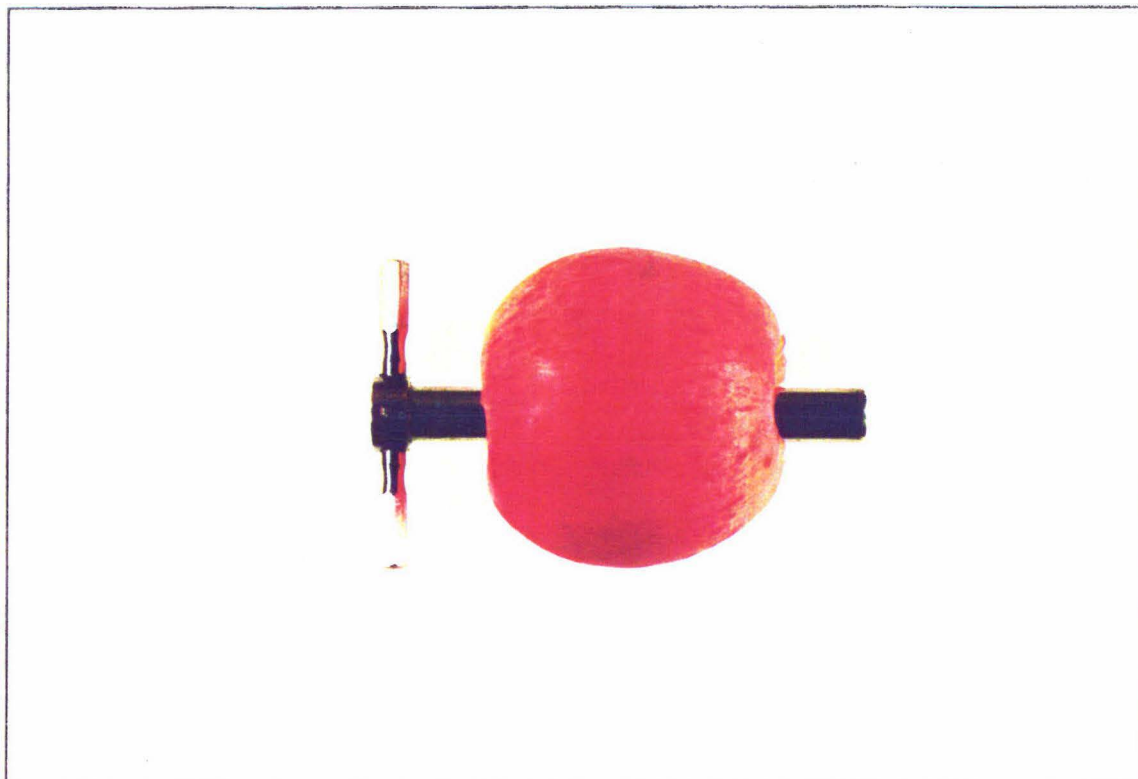

Figure 9.4 Fruit and fruit cutter

typical fruit is shown after cutting in Figure 9.5. The diameter of the cork borer was the same as the diameter of the aluminium arm. The mass of every fruit was recorded after cutting. The apple then was put onto the pendulum arm at the centre of percussion (the central groove) and released from drop angle point 1, and then caught by hand after the first impact of the pendulum in order to avoid the second impact. The impact point was marked by a marker pen, then the fruit was rotated around the pendulum arm to a different position and released from the second drop angle.

There were up to ten impacts points on each apple from ten drop heights. The procedure was repeated for twenty apples. Fruit were tested within 24 hours of harvest.

Each impact site was examined for bruising within 24 hours after completion of all

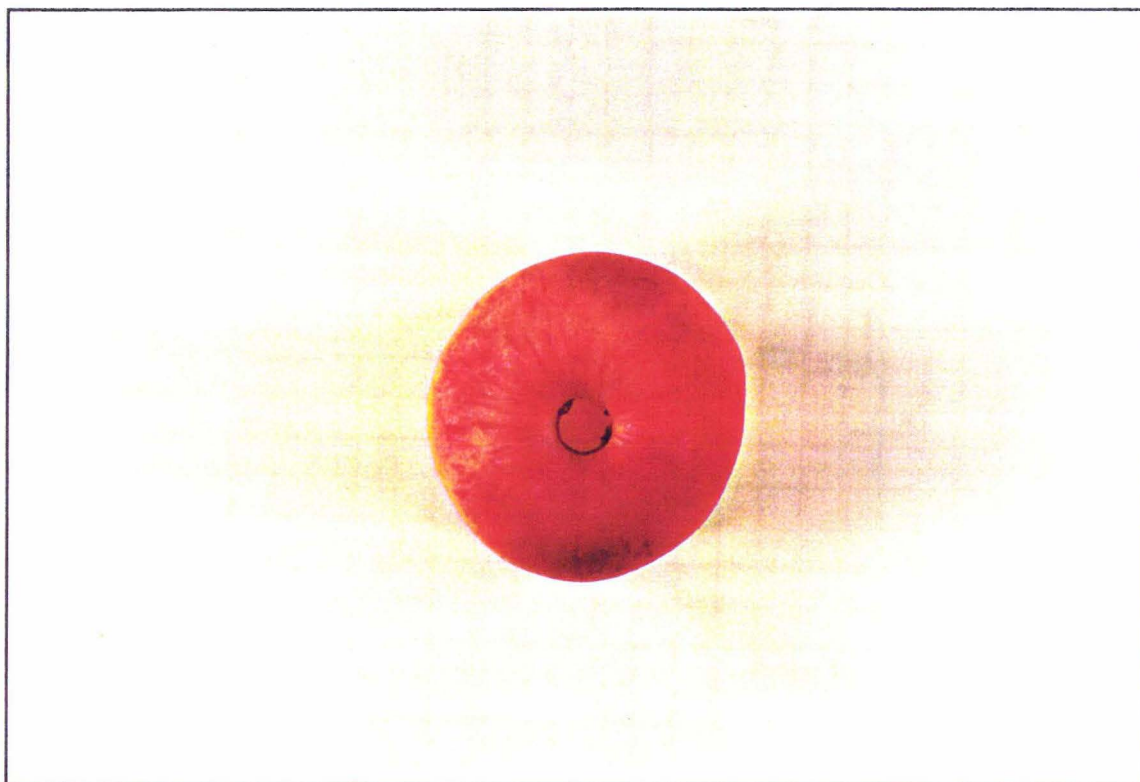

Figure 9.5 Fruit after cutting

tests. Any bruise of any size detected visually or by touch was assigned a 1, otherwise a zero was given. After completion of bruise evaluation, the number of bruises was added and divided by 20 to give a bruise number, which was defined as a Bruise Factor ranging from 0 to 10. The larger the number the more sensitive was the fruit to bruise damage.

(c) Ball drop test

The ball drop test was carried out on 20 apples from the same sample. Two drops were carried out on each fruit in the cheek area. After 24 hours, the fruit were evaluated for bruising. The bruised region was cut through the centre and its diameter and depth of the brown tissue were record for calculating bruise volume. Bruise susceptibility was defined as the ratio of average bruise volume to impact energy.

(d) Starch test

Twenty fruit from the same group of samples were selected at random for the starch test. Following the New Zealand Apple and Pear Marketing Board's guidelines, individual fruit were cut in half equatorially, the halves with the stalk end being placed in Starch/Iodine solution, as used by New Zealand Apple and Pear Marketing Board, for 2 minutes. Upon removal the total clear area was determined by comparison with the appropriate starch index pattern supplied by the Board. There were 7 scores ranging from 0 to 6 with decreasing starch content (Figure 9.6). The average of 20 readings was calculated to 1 decimal place as the result of the starch test.

(e) Other tests

Another 20 apples sampled at random were used for the penetrometer test and the brix test. A hand held Effegi penetrometer with a range of 0 - 12 kg was used, the Brix tester was a hand held Atago refractometer without temperature correction. Two penetrometer tests and two brix tests were made for each fruit. The average readings of them for the 20 apples were taken as the results of the penetrometer and brix tests respectively.

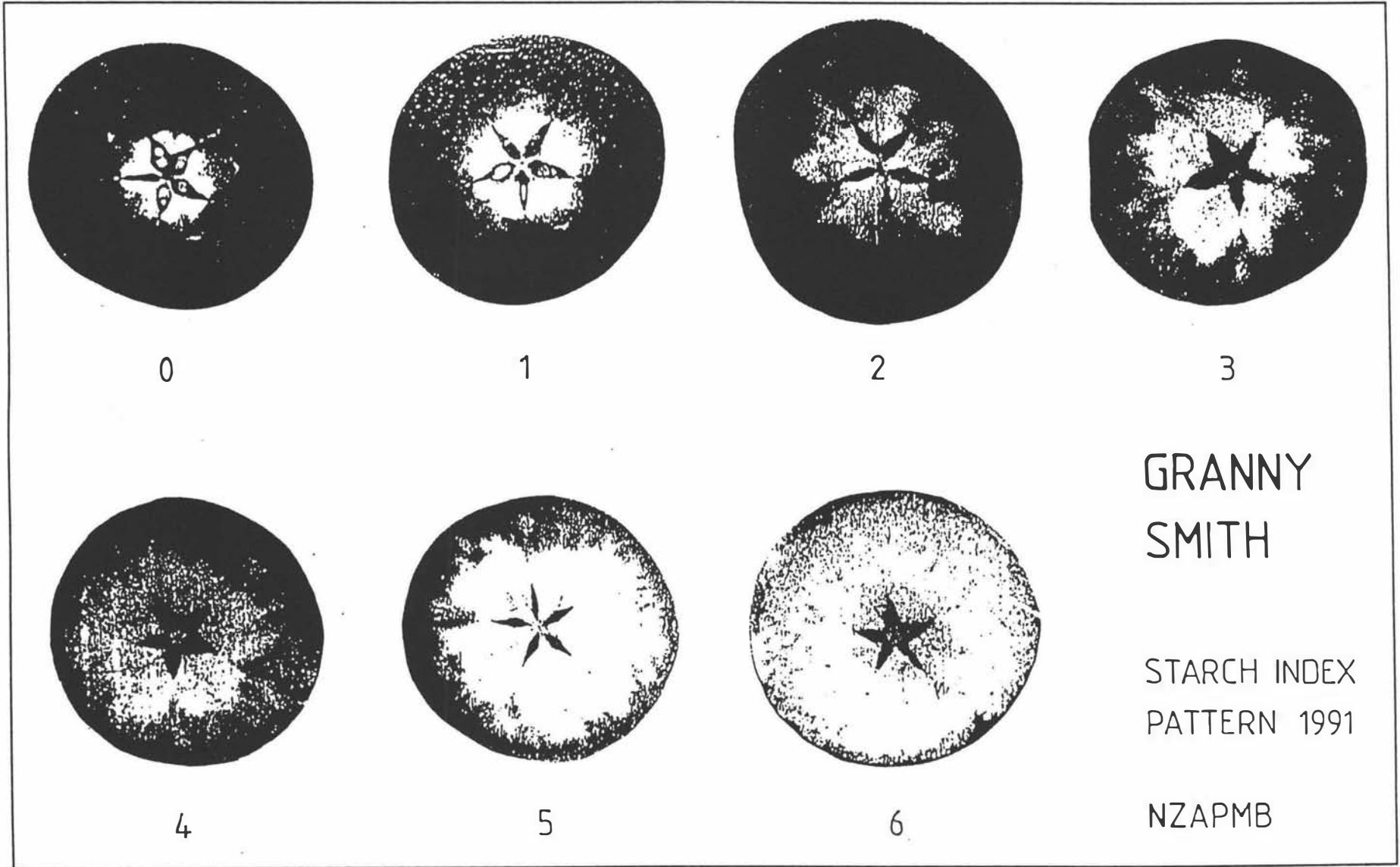

Figure 9.6 Starch index for Gala apples

9.4 Experimental results

The results of this Chapter are presented and compared with the results of Chapter 3. In particular the Bruise Factors obtained in this Chapter will be directly compared with the number of bruises produced by the grader.

9.4.1 Temperature effects on fruit properties

(a) Bruise Factor test

Figure 9.7 shows the Bruise Factors for Gala apples measured by the Bruise Factor test and the number of bruises produced by the mechanical fruit grader described in Chapter 3. From Figure 9.7 it can be seen that when fruit temperature decreased the Bruise Factor increased, and then dropped again when the fruit reached room temperature. The same trend occurred over the grader.

(b) Ball drop test

The results for Gala apples at different temperatures of impact are shown in Figure 9.8. The standard deviations were 0.11, 0.12, and 0.08 respectively for fresh, cooled, and warmed fruit. There were no significant differences in the bruise susceptibilities between the cooled fruit and the fresh or warmed fruit ($p > 0.05$).

(c) Starch test

The standard measurements of the starch test were higher in fruit at 0.5 °C than in fresh fruit at 20 °C in a reversible manner as shown in Figure 9.9, when the temperature decreased to room temperature, and the starch test dropped almost to the original level. Table 9.1 shows the statistical analysis.

The measurements for the fruit at 0.5 °C were significantly different from fresh fruit ($p < 0.05$), but there was no difference between the measurements at the same temperature at different times.

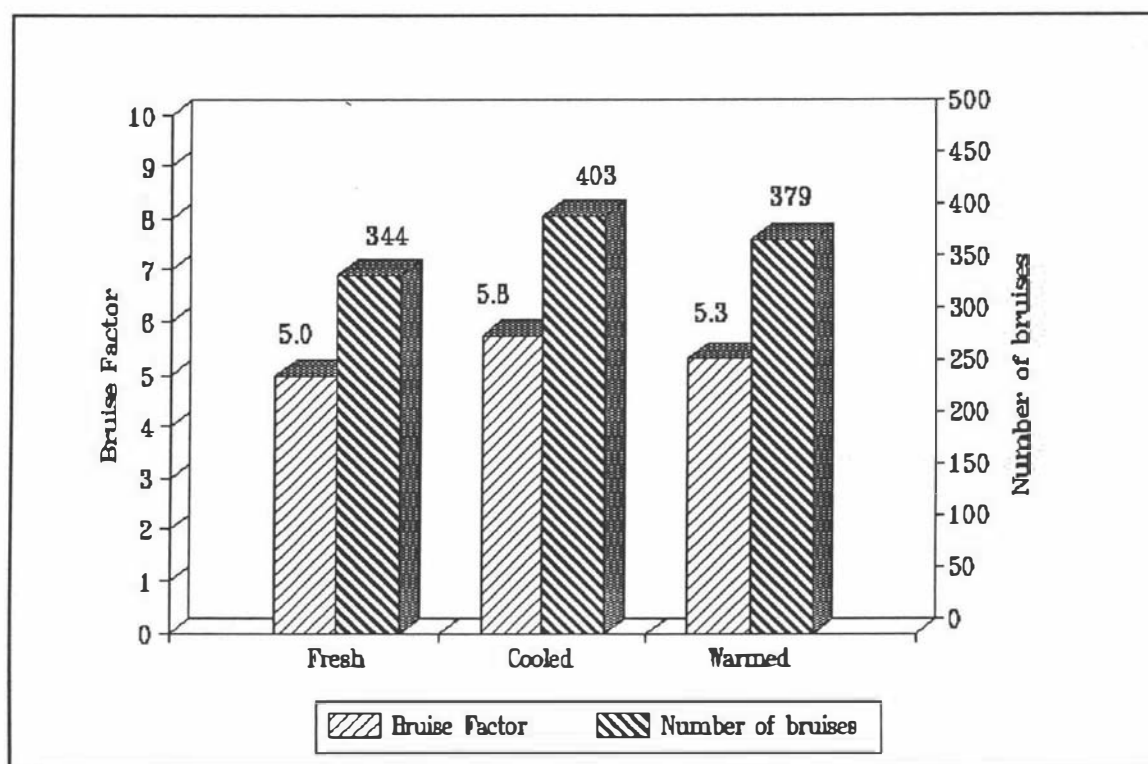

Figure 9.7 Bruise factor measured by the new approach and the number of bruises by fruit grader for Gala apples at different temperatures

Table 9.1 The statistical analysis on the measurements of starch test for Gala apples at different temperatures

| GALA | Mean | Std Dev | Std Error | Minimum | Maximum |
|--------|------|---------|-----------|---------|---------|
| Fresh | 3.2 | 0.951 | 0.213 | 1 | 5 |
| Cooled | 4.0 | 0.918 | 0.205 | 2 | 6 |
| Warmed | 3.6 | 1.395 | 0.312 | 1 | 6 |

| significance of contrast | | | |
|--------------------------|--------|----|-----------|
| comparison | T | DF | Prob > T |
| Fresh vs cooled | -2.707 | 38 | 0.010 |
| Fresh vs warmed | -0.927 | 38 | 0.360 |

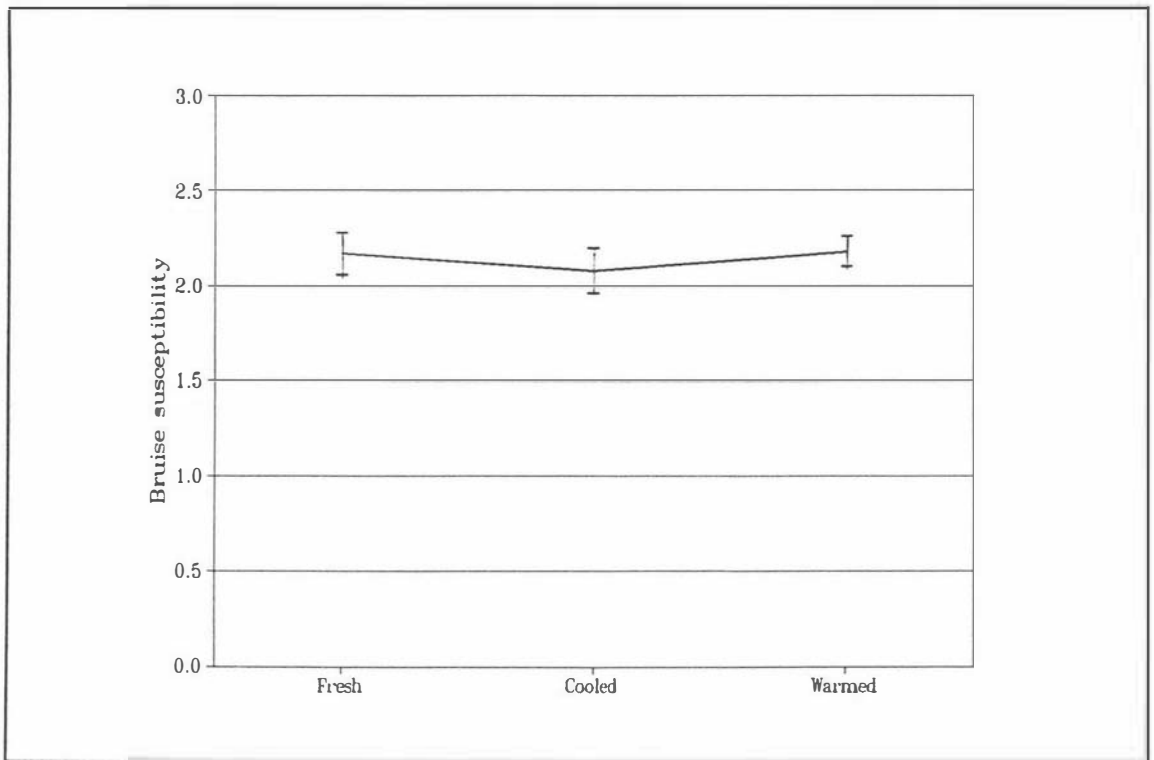

Figure 9.8 Bruise susceptibility (cm³/J) obtained by ball drop test

(d) Other tests

The average measurements of fruit firmness by a penetrometer on Gala apples at different temperatures are plotted in Figure 9.10. The tests were carried out at 20 C^o for freshly picked fruit, 0.5 C^o for cooled fruit, and 20 C^o for warmed fruit. Each reading in the figure represents the average of 20 measurements respectively. The average value for cooled fruit was slightly less than fresh and warmed fruit, but the results of statistical analysis by SAS (Statistical Analysis System) were not significantly different as shown in Table 9.2.

The sugar contents of Gala apples at different temperatures revealed opposite results to the starch test. Fruit at 0.5 C^o had more sugar, while readings decreased when fruit warmed up (Figure 9.11). The results were significantly different between fresh fruit and cooled fruit ($p < 0.05$).

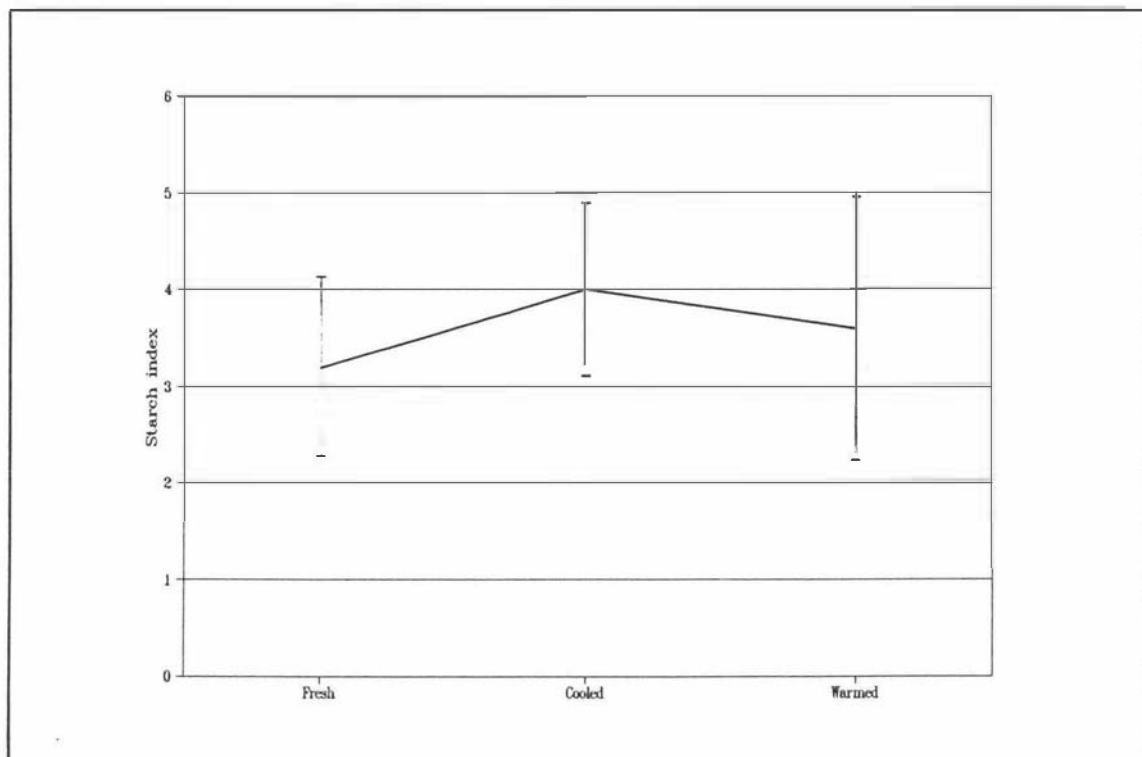

Figure 9.9 Standard measurements of starch test on Gala apple at different temperatures

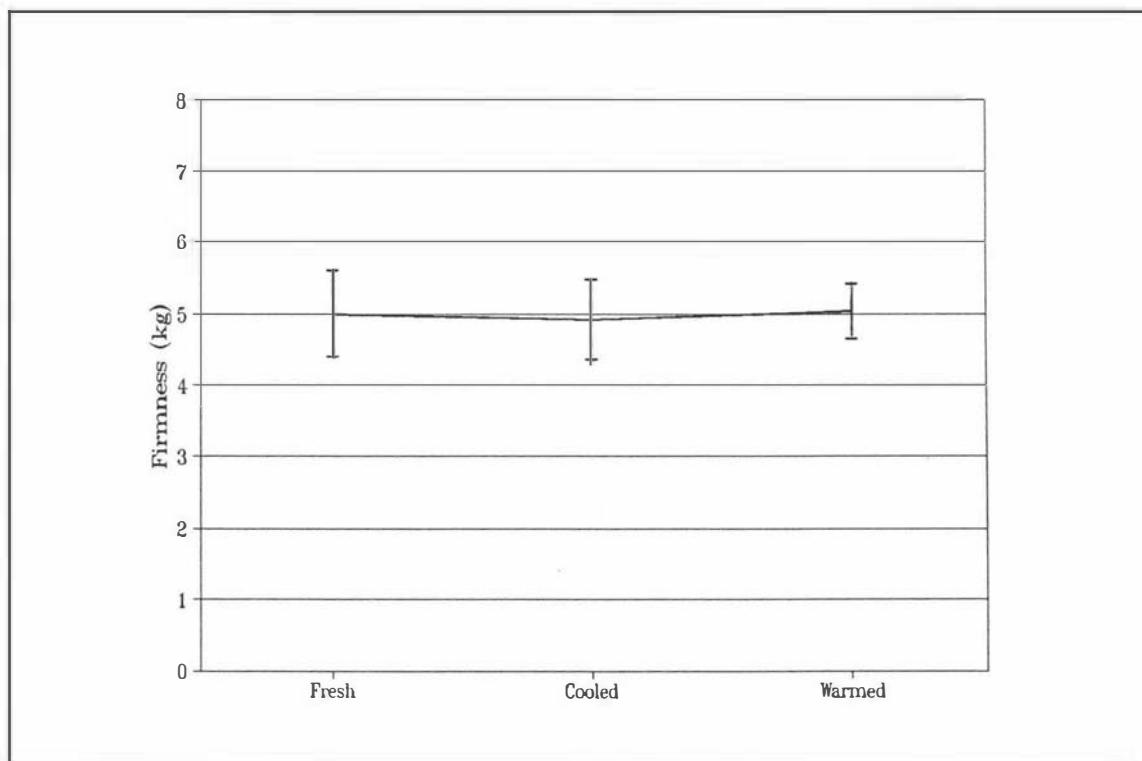

Figure 9.10 Fruit firmness of Gala apples at different temperatures measured by penetrometer

Table 9.2 Statistical analysis of fruit firmness measured by a penetrometer at different temperatures of Gala apples

| GALA | Mean | Std Dev | Std Error | Minimum | Maximum |
|--------|------|---------|-----------|---------|---------|
| Fresh | 5.00 | 0.612 | 0.137 | 4.00 | 6.05 |
| Cooled | 4.92 | 0.570 | 0.128 | 4.10 | 6.65 |
| Warmed | 5.04 | 0.385 | 0.086 | 4.55 | 5.90 |

| significance of contrast | | | |
|--------------------------|-------|----|-----------|
| comparison | T | DF | Prob > T |
| Fresh vs cooled | 0.454 | 38 | 0.65 |
| Fresh vs warmed | 0.247 | 38 | 0.81 |

9.4.2 The differences of Bruise Factors on different varieties of apples

The total number of bruises on Fuji, Granny Smith and Braeburn apples counted after passing the fruit grader were significantly different as shown in Figure 9.12. The number of bruises on Fuji apples were slightly higher than that on Braeburn apples but much less than those on Granny Smith apples. The Bruise Factors related reasonably closely to the number of bruises, although there were some differences. Reasons for these differences are discussed below.

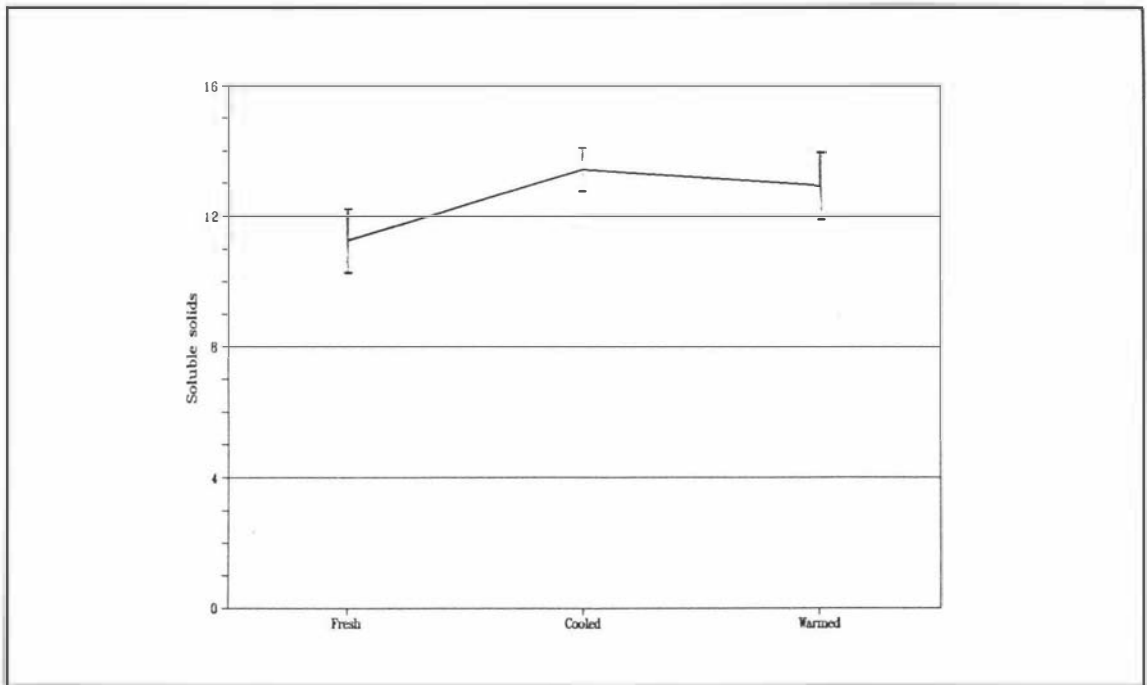

Figure 9.11 Measurements of Brix of Gala apples at different temperatures by refractometer

9.4.3 Granny Smith apples at different harvest times

The starch tests on Granny Smith apples at different harvest dates is shown in Figure 9.13. The starch index increased with the maturity of fruit. The average value of starch index ranged from 3.6 to 5.1 in a period of 20 days. This showed that the starch content in the fruit tested was decreasing with maturity.

The Bruise Factor for Granny Smith apples at the early harvest date (first harvest) was higher than that at late harvests. The Bruise Factor decreased with fruit maturity within the commercial harvest period of time (Figure 9.14).

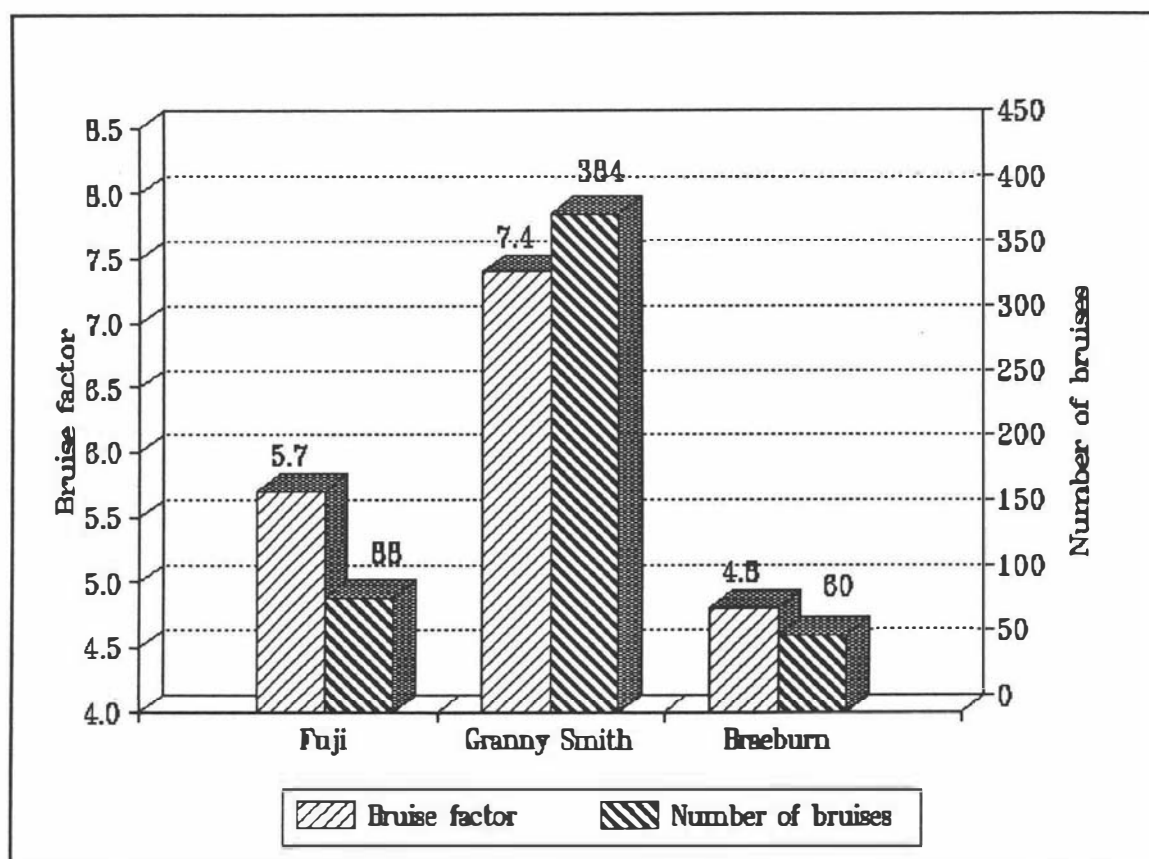

Figure 9.12 Bruise factors and the total number of bruises produced by the fruit grader for different varieties

9.5 Discussion

It is important to clarify the conceptual differences between bruise susceptibility and the Bruise Factor. Bruise susceptibility indicates the extent of bruising on fruit under impact conditions, which is a parameter related to the behaviour of fruit tissue bruised during an impact test whatever the impact method or the impact energy levels chosen. In practice, bruise susceptibility is not sufficiently sensitive to be a good predictor of actual bruising levels experienced during commercial handling (Banks, 1993). The approach used in determining Bruise Factors is to simulate the impacts on fruit experienced through a handling operation. This should relate closely to bruising sustained during handling operations, allowing for the variation in fruit size, shape and mass and perhaps most importantly the

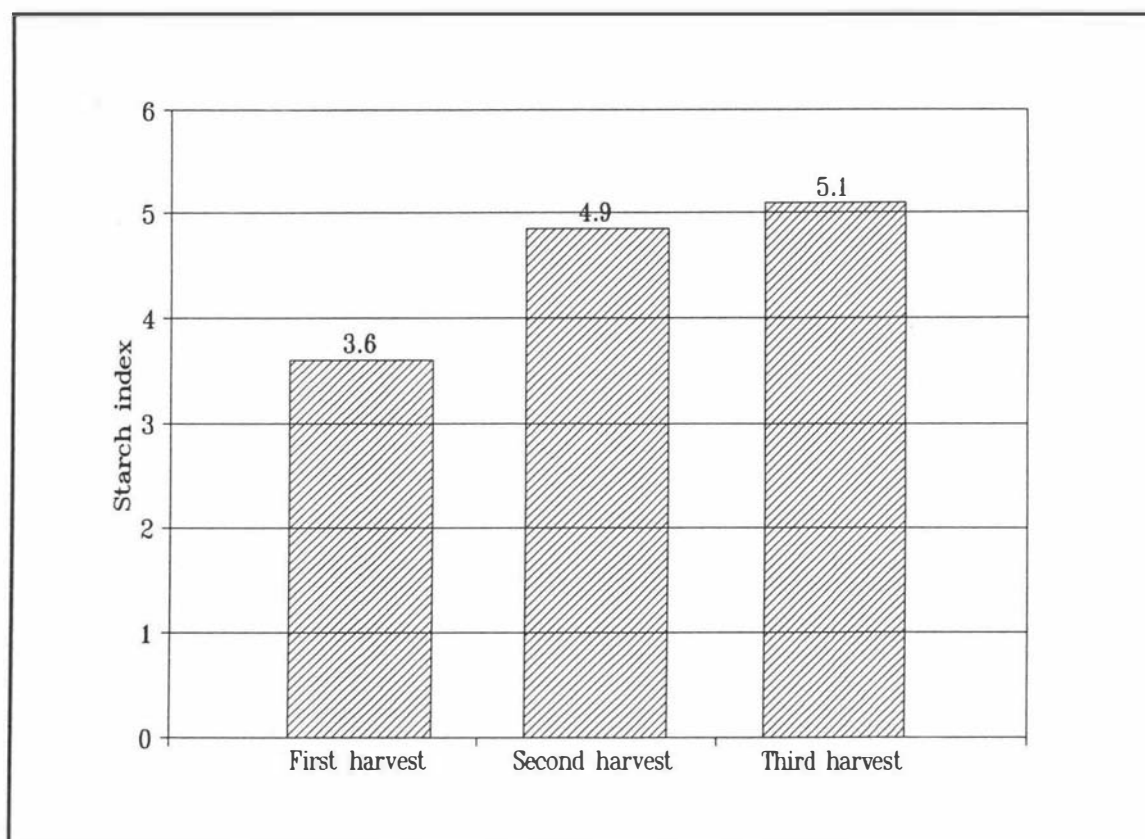

Figure 9.13 Starch tests of Granny Smith apples at different harvest dates

different impact surfaces involved in fruit collisions.

Apple temperature at impact significantly affected the amount of bruising over the grader and the Bruise Factor, which is contrary to conclusions drawn by some previous researchers on temperature effects on bruise susceptibility. Klein (1987) reported that apple temperature had no effect on bruise susceptibility while other results indicated that bruise susceptibility increased (Saltveit, 1984) or decreased (Schoorl and Holt, 1977) with increasing fruit temperature. The results of this study showed that the Bruise Factor of fresh fruit at room temperature was less than that of fruit at the temperature in cool-store, which agrees with the results of most previous researchers (e.g. Lidster and Tung, 1980; Schoorl and Holt, 1977; Mowatt and Banks, 1992) and agree with the results from fruit handling systems. It can therefore be concluded that handling fruit at low temperature may result in more

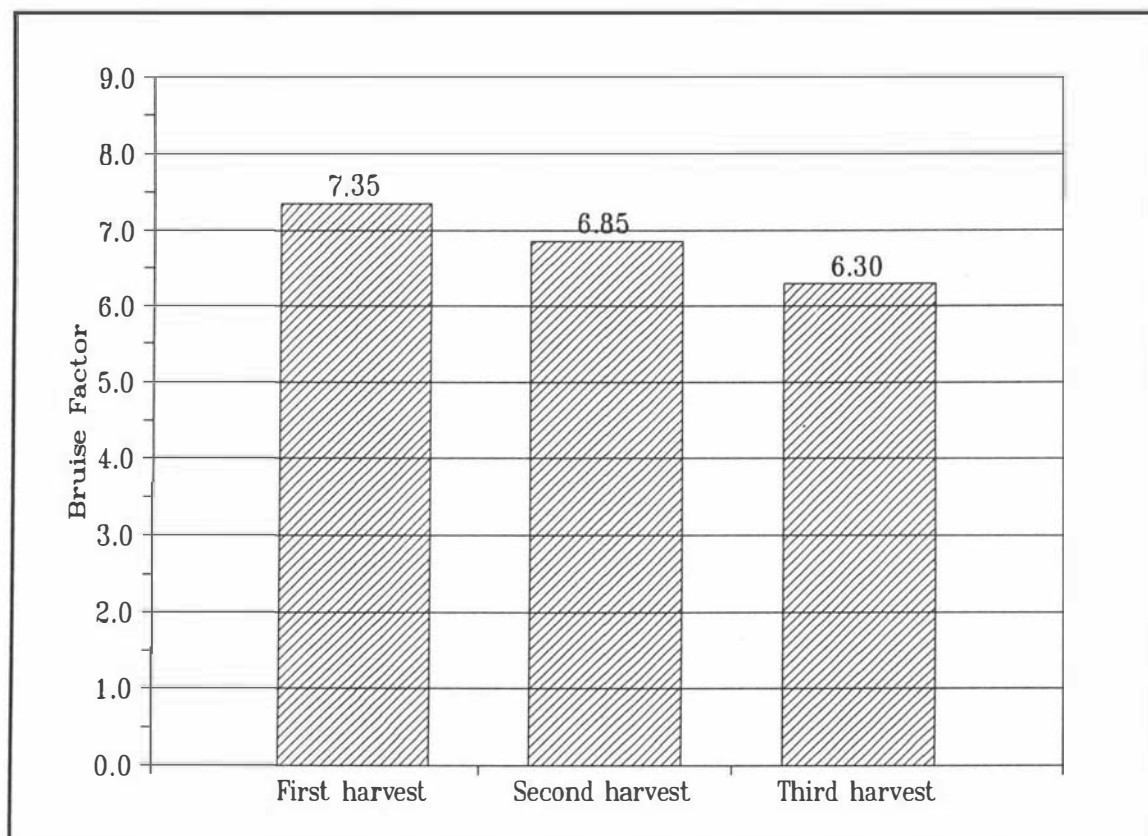

Figure 9.14 Bruise Factors of Granny Smith apples at different harvest dates

have fewer bruises, while their bruise volume in a high energy impact could be larger. The accuracy of prediction of these two approaches is thus dependent upon the distribution of possible impacts in common handling systems. In practice it is rare to find a drop height of 400 mm from a commercial packing line, and from the results of Chapter 3, it can be seen that most bruises occurred at a small range of impact levels. Different ranges of drop heights would cause different fruit responses.

Another promising point in using the Bruise Factor is that it refers to the number of bruises, thus indicating the probability of bruise occurrence for a population of apples with a given size, shape and mass of fruit, rather than the absolute size of bruise area which exceeded a certain level of bruise (e.g. 1 cm² of bruise area for New Zealand Apple and Pear Board standards).

9.6 Conclusions

1. Bruise Factor relates reasonably well to the number of bruises produced by the mechanical fruit grader. It seems to be able to indicate the severity of bruise damage produced in a fruit handling system.
2. Gala apples at low temperature had a high Bruise Factor, implying a greater probability of bruising.
3. Bruise Factor for Granny Smith apples decreased from early to late harvest time. The late harvest apples may be less likely to bruise during harvest.
4. The penetrometer test and ball drop test did not give any significant difference between treatments, indicating that these tests were not reliable indicators of the likelihood of fruit becoming bruised in a given handling system.

10. General Discussion

Apple bruise damage is still a major cause of quality loss in the fresh fruit industry and can be produced in many ways. The apple industry is particularly concerned about fruit damage during mechanical handling operations. Therefore, it is vital to understand the factors governing fruit susceptibility to bruising damage and the severity of damaging influences, and to have bruise damage quantified and damaging influences identified.

10.1 Apple bruising on commercial packing lines

Surveys of grading equipment (eg. Banks, 1991) have shown that drop heights involved did not exceed 300 mm and that the damage which did occur during a large drop appeared to be less than what might be expected because of padding. In contrast, small impacts and apple to apple impacts caused more bruises which often exceeded the commercial standard for maximum acceptable bruise size for export. Consequently, it is more important to determine the bruise susceptibility for a range of small drop heights and for apple-to-apple impacts.

In the analysis of bruise damage produced by a fruit grader (in Chapter 3), a large percentage of bruises were less than 1.5 cm^2 in area, and the number of bruises above 1.5 cm^2 did not change between less sensitive and more sensitive fruit (Figure 3.6). It is not adequate to say there was no change at all in bruise area, but the change was not enough to show a difference in fruit bruise levels. This implied that any study on bruise susceptibility based on bruise areas above 1.5 cm^2 may result in a solution which is not related to the real bruisability of fruit in mechanical handling operations because of the excessive range of impact energy. It was shown in Chapter 5 that the responses of fruit for different ranges of impact energy levels

do behave differently. In particular, in Figure 5.6 it was shown that the coefficient of restitution (e) varied in a non-linear manner with impact energy level. For apple-to-apple impacts the coefficient of restitution decreased sharply in the impact energy range from 0 to 0.2 J, while above 0.2 J, it approached a constant value of 0.48. The relationship between total bruise volume and e showed a low correlation when the value of e was above 0.7 (Figure 5.7).

Although there is some debate about using elasticity theory, it is useful to assist in discussing impact dynamics as shown in Chapter 5. According to the theory, the contact area of impact is related to the impact energy, modulus of elasticity, and radii of the impacting objects. Assuming that the modulus and radius terms are unchanged, then the contact area is proportional to the two-fifth power of impact energy (Chapter 5). Thus it could be assumed that at a constant impact energy levels, the contact area of the impact would remain the same in all situations. In fact, the above assumption is valid only for impact onto hard flat surfaces, when the radii, modulus, and mass of the object struck can be considered infinite (Section 5.5). Elasticity theory suggests that variations of fruit size, fruit variety, and fruit maturity will have minor effects on contact area. However during fruit-to-fruit impacts, the contact area will be only 76% of the contact area compared to when fruit impact onto hard surfaces.

Experimentally, bruise area was found to be proportional to contact area once there was a bruise greater than 1 cm^2 in the contact area as described in Chapter 5. In a mechanical handling operation, if the possibility of an impact occurring and the impact energy levels is unchanged, then the bruise area after bruise initiation will also not change significantly regardless of the maturity of the fruit. This agrees with the results of the fruit grader study in Chapter 3, which showed that the number of bruises of above 1 cm^2 on cooled Gala apples ($0.5 \text{ }^\circ\text{C}$) remained unchanged. However the same study showed that the number of bruises under 1 cm^2 increased

on the cooled fruit. This implied that bruise initiation may offer a more reliable way of quantifying the bruise levels produced by fruit handling systems, rather than the bruise susceptibility test, which depends on bruise size or volume.

10.2 Quantification of apple bruising

There are three main ways of describing apple bruising. These are bruise volume, bruise area, and the number of bruises. The methods of determining bruise volume and bruise area are well recognized. The ratio of bruise volume to impact energy absorbed has been defined as the bruise susceptibility (Schoorl and Holt, 1977), while the bruise area and the cumulative bruise area (1 cm^2) are used by the fruit industry as criteria for apple bruising. In scientific literature, the cumulative effect of a number of small bruises is not well discussed. The study of bruise damage produced by a mechanical fruit grader in Chapter 3 showed that the number of small bruises could be a very important variable for quantifying the bruise damage produced by fruit handling systems.

While Holt and Schoorl (1977) used the ratio of the bruise volume to the energy absorbed in the impact of fruit onto a flat hard surface as a bruise susceptibility coefficient (cm^3/J), the ratio of bruise area to impact energy has obviously been considered as a quantity which may offer greater potential as an easy way to determine fruit bruising. This is because measuring bruise volume is a time consuming process, while bruise area on the fruit surface is easier to measure. Similarly the total impact energy is much easier to obtain than energy absorbed in practical situations. However, the results of this study showed that the ratio of bruise area to impact energy may not be able to indicate differences of bruise susceptibility at different times of storage (Chapter 8). The sizes of bruises above 1.5 cm^2 also were not significantly different when Gala apples passed through a fruit

grader at lower temperature (Chapter 3). In contrast, it was found that the total number of bruises may give a good indication of fruit susceptibility to bruise damage, and the number of bruises produced by a grader can be predicted by the Bruise Factor method as discussed in Chapters 3 and 9.

There are conceptual differences between the ratio of bruise volume to the energy absorbed and Bruise Factor. The former indicates the amount of bruising tissue produced in an impact. The Bruise Factor simulates the range of impacts fruit experience through a handling operation and the measurement is based on the probability of bruise initiation. It is argued that the results should then relate more closely to the overall bruise severity in terms of the total number of bruises over the practical range of impact levels than other bruise tests. Bruise Factor is a parameter for indicating fruit bruisability during fruit handling operations, which could be used to characterise seasonal differences, variety differences, the effects of temperature, and the effects of storage. More importantly, the present results suggest that it may be better related to the bruise damage produced by a commercial handling system.

As described in Chapter 7 and elsewhere, the impact surface has a great effect on bruise levels, and the surface used for determining bruise susceptibility must be specified. The surface for determining Bruise Factor was flat steel for simplicity.

10.3 Prediction of bruising by using an Instrumented Sphere

As discussed above, Bruise Factor can indicate the different responses of fruit as they pass through the same handling operation. However, it does not determine differences of bruise potential for different handling systems.

The Instrumented Sphere (IS) has been developed to identify and measure impacts on fruit and other crops during handling operations (Zapp et al., 1989; Brown et al., 1990). In such operations fruit are subjected to a large number of impacts. One major source is where a falling fruit impacts onto a fixed hard surface or a padded surface. However, these impacts can be minimised by more padding, and by altering the design. The second source of impacts is fruit-to-fruit impacts. There are a large number of such impacts during sorting, grading, and packing, which cannot be avoided with present equipment and handling methods. The results of this study showed that these impacts can be identified by the IS (as illustrated in Figure 4.11) while regions where bruising is likely to occur from fruit-to-fruit impacts can also be identified.

While previous research studies have discussed the use of the IS to predict bruising of fruit against flat steel surfaces and padded flat surfaces, relatively little published data is available reporting impacts against non-flat surfaces and simulations of fruit-to-fruit impacts as commonly found on packing lines. In this study, apple-to-apple impacts and non-flat surface impacts were particularly included (Chapters 4 and 5). A bruise threshold was determined for each surface for five varieties of apple, and a potential bruise boundary was then developed for each variety by joining the threshold points on the surface response lines. It is argued that this boundary is more reliable for predicting bruise potential of impacts recorded by the Instrumented Sphere on commercial packing lines than previously reported bruise threshold curves based on flat cushioned surfaces. It is also argued that the method of testing fruit grading machines by using an Instrumented Sphere as described in this study should be standardized for the fruit industry.

10.4 Suggestions for future work

1. With a new generation of Instrumented Sphere and more research work, the differences between bruise threshold curve and bruise boundary could be clarified. The analysis of Instrumented Sphere output could be improved by introducing the bruise boundary developed in this study into the software.
2. More work may be needed in order to examine the reliability of Bruise Factor for fruit over a wide range of conditions by comparing the Bruise Factor values obtained with amounts of damage incurred on grading equipment.
3. The relationship between bruise initiation and bruising related to commercial handling systems needs to be examined.

11. SUMMARY AND CONCLUSIONS

Experiments have been conducted on the measurement of bruising in apples. Particular emphasis has been given to relating bruising measurements to practical situations. An Instrumented Sphere has also been studied in detail for a wide range of impact situations including fruit-to-fruit impacts.

An Instrumented Sphere (IS), 89 mm in diameter with a mass of 0.336 kg, which recorded acceleration magnitudes above an adjustable pre-programmed threshold, was used to characterize impacts onto fruit. During fruit-to-fruit impacts, bruising was generally more severe on one of the two apples, and it was quite common for only one apple to be damaged. When the results of apple-to-apple and IS-to-apple impacts were compared, it was found that the area of the larger of the two bruises produced in fruit-to-fruit impacts was directly related to the peak acceleration recorded by the IS when it was dropped onto a fruit from the same height. Using this comparison, damage thresholds resulting from fruit-to-fruit impacts were determined and included in the analysis of IS output.

It was concluded that the IS can be used to identify situations in which apple-to-apple impacts are likely to cause bruising in commercial packing operations, providing care is taken with interpretation of the data by using a technique such as described by Bollen and Dela Rue (1991).

Impacts against non-flat surfaces have been also studied. Impact tests have been conducted on freshly picked Gala, Splendour, Fuji, Braeburn, and Granny Smith apples, all grown in Hawkes Bay, New Zealand. Bruise areas produced during impact onto flat steel, rubber, plastic tubing, and a solid plastic bar, were found to be linearly correlated with the peak acceleration recorded by an IS dropped from

the same heights.

For each variety and each surface, the drop height required to produce a critical bruise with a surface area of 1 cm^2 (as measured with the skin removed) was determined. By correlating the IS output with the bruise area on each surface, a threshold potential bruise boundary was produced on a velocity change against acceleration graph. The boundary curve, which included apple-to-apple impact, was hyperbolic in shape, rather than the boundary line described in other studies.

A study of free normal impact between pairs of Granny Smith apples was conducted. It was found that there was a non-linear relationship between contact area and impact energy, but the two were related by a $2/5$ power law as predicted by elasticity theory. It was also found that the coefficient of restitution varied in a non-linear manner with impact energy, decreasing as the impact energy increased, to reach an asymptotic value.

The methods of measuring bruising of fruit under impact loading were critically analyzed. It was found that the bruise area may not give useful information as a means of determining bruise susceptibility. Effects of different impact surfaces on area-based measures of bruising were also detected, so that the impact surface used in experimentation should also be specified.

Bruises on Gala apples produced by a mechanical grader were more visible on the green compared to the red side of fruit and in the cheek compared to other areas on the fruit surface. A large percentage of bruises were under 1 cm^2 in area and it was rare to have any bruise above 3 cm^2 . The range of bruise areas differed from what has been used by some previous research workers.

The Bruise Factor related closely to the number of bruises produced by the

mechanical fruit grader. Preliminary studies indicated a reasonable prediction of the bruise damage occurring within a fruit handling system.

Gala apples at low temperature had a higher starch index (lower starch content and higher Brix level), higher Bruise Factor, and larger number of bruises when they passed through the grader. Bruise Factor for Granny Smith apples decreased from early to late harvest time.

The results of this study should give a basic understanding of characterising bruise damage influences. The quantification of bruising produced by fruit handling systems will provide valuable information to scientists and the fruit industry.

12. REFERENCES

- Aldred, W. H. and Burch, J. J., 1977. Telemetry and microcomputer system aids investigation of forces on peaches during mechanical harvesting. ASAE Paper No. 77-1527.
- Anderson, G. and Parks, R., 1984. The electronic vegetable. Scottish Centre of Agricultural Engineering.
- Banks, N. H., 1991. Reduction of mechanical damage in New Zealand apples. A progress report to the New Zealand Apple and Pear Marketing Board. Department of Horticultural Science, Massey University, Palmerston North, New Zealand. 44 pp.
- Banks, N. H., 1990. Personal communication.
- Banks, N. H., 1992. Unpublished data.
- Banks, N. H., 1993. Personal communication.
- Bollen, A. F. and Cox, N. R., 1991. A technique for predicting the probability of bruising for use with an Instrumented Sphere. ASAE Paper No. 91-6595.
- Bollen, A. F. and Dela Rue, B. T., 1990. Impact analysis using video with an Instrumented Sphere. ASAE Paper No. 90-6078.
- Bollen, A. F. and Dela Rue, B. T. 1991. Use of an Instrumented Sphere in determining the impact damage potential of postharvest handling systems. Abstract, Australasian Postharvest Conference, Flock House, Bulls, New Zealand.
- Bourne, M. C., 1965. Studies on punch testing of apples. Food Technolo. 19(3), 113-115.
- Brown, G. K.; Schulte Pason, N. L.; Timm, E. J.; Burton, C. L. and Marshall, D. E., 1990. Apple packing line impact damage reduction. Applied Engineering in Agriculture, 6(6): 759-764.
- Brown, G. K.; Burton, C. L.; Sargent, S. A.; Schulte Pason, N. L.; Timm, E. J. and Marshall, D. E., 1987. Apple packing line damage assessment. ASAE

Paper No. 87-6515.

- Brusewitz, G. H. and Bartsch, J. A., 1989. Impact parameters related to post-harvest bruising of apples. *Transactions of the ASAE*. 32(3): 953-957.
- Brusewitz, G. H.; McCollum, T. G. and Zhang, X., 1991. Impact bruise resistance of peaches. *Transactions of the ASAE*. 34(3): 962-965.
- Chen, P. and Sun, Z., 1981. Impact parameters related to bruise injury in apples. ASAE Paper No. 81-3041.
- Chen, P.; Tang, S. and Chen, S., 1985. Instrument for testing the response of fruits to impact. ASAE Paper No. 85-3537.
- Chen, P. and Yazdani, R., 1991. Prediction of apple bruising due to impact on different surfaces. *Transactions of the ASAE*. 34(3): 956-961.
- Diener, R. G.; Elliott, K. C.; Nesselroad, P. E.; Inhle, M.; Adams, R. E. and Blizzard, S. H., 1979. Bruise energy of peaches and apples. *Transactions of the ASAE*. 22(2): 287-290.
- Finney, E. E. Jr. and Massie, D. R., 1975. Instrumentation for testing the response of fruits to mechanical impact. *Transactions of the ASAE* 18(6): 1184-1187,1192.
- Franke, J. E. and Rohrbach, R. P., 1981. A nonlinear impact model for a sphere with a flat plate. *Transactions of the ASAE* 24(6): 1683-1686.
- Garcia, C.; Ruiz, M. and Chen, P., 1988. Impact parameters related to bruising in selected fruits. ASAE Paper No. 88-6027.
- Gaston, H. P. and Levin, J. H., 1951. How to reduce apple bruising. Michigan State College Agricultural Experiment Station, Special Bulletin 374.
- Guyer, D. E.; Schulte-Pason, N. L.; Timm, E. J. and Brown, G. K., 1990. How to minimize apple bruising in the packing line. ASAE Paper No. 90-6008.
- Halderson, J. L.; Peterson, C. L. and Daigh, R. C., 1983. A telemetry device for impact detection. *Agricultural Electrics*. 2: 773-780.
- Hamann, D. D., 1970. Analysis of stress during impact of fruit considered to be viscoelastic. *Transactions of the ASAE* 13(6): 893-899.

- Holt, J. E. and Schoorl, D., 1977. Bruising and energy dissipation in apples. *Journal of Textural Studies* 7: 421-432.
- Holt, J. E. and Schoorl, D., 1980. Bruise resistance measurements in apples. *Journal of Textural Studies* 11: 389-394.
- Holt, J. E. and Schoorl, D., 1983. Fracture in potatoes and apples. *Journal of Materials Science* 18: 2017-2028.
- Holt, J. E. and Schoorl, D., 1984. Package protection and energy dissipation in apple packs. *Scientia Horticulturae*. 24: 165-176.
- Holt, J. E. and Schoorl, D., 1985. A theoretical and experimental analysis of the effects of suspension and road profile on bruising in multilayered apple packs. *J. Agric. Engng Res.* 31: 297-308.
- Holt, J. E.; Schoorl, D. and Lucas, C., 1981. Prediction of bruising in impacted multilayered apple packs. *Transactions of the ASAE*. 24(1): 242-247.
- Horsfield, B. C.; Fridley, R. B. and Claypool, L. L., 1972. Application of theory of elasticity to the design of fruit harvesting and handling equipment for minimum bruising. *Transactions of the ASAE* 15(4): 746-750, 1192.
- Howard, V., 1990. Private Communication.
- Hung, Y. C. and Prussia, S. E., 1989. Effect of maturity and storage time on the bruise susceptibility of peaches (CV. Red Globe). *Transactions of the ASAE* 32(4): 1377-1382.
- Hyde, J. F. and Ingle, M., 1968. Size of apple bruise as affected by cultivar, maturity, and time in storage. *Proc. Amer. Soc. Hort. Sci.* 92:737-738.
- Jenkins, W. H. and Humphries, E. G., 1982. Impact damage assessment technique. *Transactions of the ASAE* 25(1): 54-57.
- Klein, J. D., 1987. Relationship of harvest date, storage conditions, and fruit characteristics to bruise susceptibility of apple. *J. Amer. Soc. Hort. Sci.* 112(1): 113-118.
- Kosma, A., and Cunningham, H., 1962. Tables for calculating the compressive surface stresses and deflections in the contact of two solid elastic bodies

- whose principal do not coincide. *Journal of Industrial Math.* 12(1): 31-40.
- Lee, E. H., and Rodak, J. R. M., 1960. The contact problem for viscoelastic bodies. *Journal of Applied Mech.* 27(9): 432-444.
- Lidster, P. D., and Tung, M. A., 1980. Effects of fruit temperatures at time of impact damage and subsequent storage temperature and duration during on the development of surface disorders in sweet cherries. *Can. J. Plant Sci.* 60:555-559.
- Manor, A. N., 1978. Critical analysis of the mechanics of fruit damage under impact conditions. Ph.D Thesis, Department of Agricultural Engineering, Pennsylvania State University, University Park, Pennsylvania, USA.
- Marshall, D. E. and Burgess, G. J., 1990. Damage criteria applied to apples. ASAE Paper No. 90-6003.
- McLeod, S., 1992. Fresh fruit research manager, New Zealand Apple and Pear Marketing Board. Personal communication.
- Mohsenin, N. N., 1984. *Physical Properties of Plant and Animal Materials*, 2nd ed. New York: Gordon & Breach Science Publishers.
- Mohsenin, N. N., 1970. *Physical properties of plant and animal materials*. Gordon and Breach: New York.
- Mowatt, G. and Banks, N. H., 1992. Private communication.
- Nelson, C. W. and Mohsenin, N. N., 1968. Maximum allowable static and dynamic loads and effect of temperature on mechanical injury in apples. *J. Agric. Engng. Res.* 13,305.
- New Zealand Apple and Pear Marketing Board, 1990. Quality control charts for fruit packers.
- New Zealand Apple and Pear Marketing Board, 1982. Export apple packaging trial.
- Nicholas, J. V., 1992. Pipmark. Technical Bulletin, Dec.
- O'Brien, M.; Fridley, R. B.; Goss, J. R. and Schubert, J. F., 1973. Telemetry for investigating forces on fruit during handling. *Transactions of the ASAE*

- 16(2):245-247.
- Opara, L.; Studman, C. J. and Banks, N. H., 1991. Economic value of bruise damage in apple based on consumer assessment. *New Zealand Agricultural Science*, Volume 26.
- Pang, W.; Studman, C. J. and Banks, N. H., 1992. Analysis of damage thresholds in apple-to-apple impacts using an instrumented sphere. *New Zealand Journal of Crop and Horticultural Science*. 20(2): 159-166.
- Pang, W.; Studman, C. J. and Banks, N. H., 1991a. Use of an Instrumented Sphere for Assessing Apple Bruising Thresholds. ASAE Paper No. 91-6596.
- Pang, W.; Studman, C. J. and Ward, G. T., 1991b. Bruising damage in apple-to-apple impact. *J. Agric. Engng Res*. 52(4): 229-240.
- Peleg, K. 1984. A mathematical model of produce damage mechanisms. *Transactions of the ASAE* 27(1): 287-293.
- Saltveit, M. E. Jr., 1984. Effects of temperature on firmness and bruising of 'starkrimson delicious' and 'golden delicious' apples. *Hort. Science*. 19(4): 550-551.
- Schoorl, D. and Holt, J. E., 1974. Bruising and acceleration measurements in apple packs. *Queensland Journal of Agricultural and Animal Sciences*. 31(1): 83-92.
- Schoorl, D. and Holt, J. E., 1977. The effects of storage time and temperature on the bruising of Jonathan, Delicious and Granny Smith apples. *Journal of Texture Studies*. 8: 409-416.
- Schoorl, D. and Holt, J. E., 1980. Bruise resistance measurements in apples. *Journal of Texture Studies*. 11: 389-394.
- Schulte-Pason, N.L.; Timm, E.J. and Brown, G.K., 1990. Apple, peach and pear impact damage thresholds. ASAE Paper No. 90-6002.
- Siyami, S.; Brown, G. K.; Burgess, G. J.; Gerrish, J. B.; Tennes, B. R.; Burton, C. L. and Zapp, R. H., 1988. Apple impact bruise prediction models.

- Transactions of the ASAE. 31(4): 1038-1046.
- Sober, S. S.; Zapp, H. R. and Brown, G. K., 1989. Simulated packing line impacts for apple bruise prediction. ASAE Paper No. 89-6047.
- Studman, C. J., 1990. Apple handling damage in New Zealand. ASAE Paper No. 90-6079.
- Studman, C. J. and Banks, N. H., 1990. The measurement of bruise susceptibility in apples and nashi. Proceedings of International Conference of Agricultural Engineering, Beijing, China, Vol. 3, 31-36.
- Studman, C. J., and Pang, W., 1990. Mechanics of fruit damage. Project Report to New Zealand Apple and Pear Marketing Board. Agricultural Engineering Department, Massey University, Palmerston North, New Zealand.
- Studman, C. J.; Pang, W. and Banks, N. H., 1991. Mechanics of fruit damage. Annual report to the New Zealand Apple and Pear Marketing Board. Agricultural Engineering Department, Massey University, Palmerston North, New Zealand.
- Tennes, B. R.; Zapp, H. R. and Brown, G. K., 1986. Detection and monitoring device for perishables. ASAE Paper No. 86-3029.
- Tennes, B. R.; Zapp, H.R.; Marshall, D.E. and Armstrong, P.R., 1990. Apple handling impacts data acquisition and analysis with an Instrumented Sphere. J. Agric. Engng Res. 47: 269-276.
- Tennes, B. R.; Zapp, H. R.; Marshall, D. E. and Armstrong, P. R., 1988. Bruising impact data acquisition and analysis in apple packing and handling systems utilizing the Instrumented Sphere. ASAE Paper No. 88-6032.
- Timm, E. J.; Schulte Pason, N. L.; Brown, G. K. and Burton C. L., 1989. Apple and impact surface effects on bruise size. ASAE Paper No. 89-6048.
- Timoshenko, S. P. and Goodier, J. N., 1970. Theory of elasticity. McGraw-Hill, New York.
- Turczyn, M. T.; Grant, S. W.; Ashby, B. H. and Wheaton, F. W., 1986. Potato shatter bruising during laboratory handling and transport simulation.

Transaction of the ASAE 29(4): 1171-1175.

Zapp, H. R.; Brown, G. K.; Armstrong, P. R. and Sober, S.S., 1989. Instrumented Sphere performance: Dynamic Measurements and Demonstration. ASAE Paper No. 89-0008.

Appendix A

Contents of CAL.10

| | slope | intercept offset |
|---|-------|------------------|
| X | 3.990 | 128 |
| Y | 3.672 | 128 |
| Z | 3.781 | 128 |

Appendix B

This computer programme was used to convert the Instrumented Sphere output file from hexadecimal format to a integer file.

```

program convert;
var inf, outf :text; {files of text}
    inname, outname : string;
    ch1, ch2 : char;
    i, j, k, value, numberofreadings, val1, val2, val3: integer;
label exit;

function hex_to_int(ch : char) :integer;
var value : integer;
begin
    ch:= upcase(ch);
    if ch in ['0'..'9'] then value:= ord(ch) - ord('0')
    else {must be in range 'A'..'F'}
        value:= ord(ch) - ord('A') + 10;
    hex_to_int:= value;
end;

{Read two characters from the hex file and convert it to an integer}
function Nextnum : integer;
var ch1, ch2 : char;
    value : integer;
begin

```

```

    i:= i+1;
    read(inf, ch1, ch2);
    value:= 16 * hex_to_int(ch1) + hex_to_int(ch2);
    nextnum:= value;
end;

begin
    writeln('Convert a file of hex to a file of integers');
    writeln;
    write('Input file : '); readln(inname);
    assign(inf, inname);
    {$I-} reset(inf); {$I+}
    if ioreult < > 0 then
        begin
            writeln('Couldn't find "',inname,'"');
            halt(1)
        end;
    write('Name of output file : '); readln(outname);
    assign(outf, outname);
    rewrite(outf);
    i:= 0; {used to keep a track of which number (not character) we're on}

    {Don't know what the first 9 values are -just print them out}
    for j:= 1 to 9 do
        begin
            value:= nextnum;
            writeln(outf, i:4, ' ',value:4, ' ', chr(value));
            writeln(i:4, ' ',value:4, ' ', chr(value));
        end
    end
end

```

```
end;

{Values 10 to 34 (or 35?) are the filename .... print it
 out}
while chr(value) <> #13 do
  begin
    value:= nextnum;
    write(outf, chr(value));
    write(chr(value));
  end;
writeln(outf);
writeln;
while not eof(inf) do begin
  writeln; writeln(outf);
  val1:=nextnum; val2:= nextnum;
  if eof(inf) then goto exit;
  numberofreadings:= val1*256+ val2;
  value:= nextnum; value:= nextnum; value:= nextnum; value:= nextnum;
  for k:=1 to numberofreadings do begin
    val1:= nextnum; val2:=nextnum; val3:=nextnum;
    writeln(outf,val1:4,val2:4,val3:4);
    writeln(val1:4,val2:4,val3:4);
  end;
end;
exit:
close(inf);
close(outf);
end.
```

Appendix C

In this particular impact there were 24 sample points. The number of sample points depended on the nature of the impact, and the duration of the impact was calculated from the time interval based on the sample rate selected by the user (0.256 ms used in this study) multiplied by the number of sample points. A leader length of 9 counts and trailer length of 9 were used in this example.

The original integer format of Instrumented Sphere output

- 1 16 IS serial number
- 2 1 Header length
- 3 38 Termination flag
- 4 2 Sampling rate
- 5 3 Threshold digital count
- 6 9 Leader length
- 7 9 Trailer length
- 8 21 file size (MSB = most significant bit)
- 9 132 File size (LSB = least significant bit)

calibra2 08-12-1990 14:08:51 (user message and date)

(X Y Z)

- 127 126 128 (sample point 1)
- 127 126 128 (sample point 2)
- 127 126 128 (sample point 3)
- 127 126 128 (sample point 4)

| | |
|-------------|---|
| 127 126 128 | (sample point 5) |
| 127 126 128 | (sample point 6) |
| 127 126 128 | (sample point 7) |
| 127 127 128 | (sample point 8) |
| 127 126 128 | (sample point 9) |
| 126 126 133 | (sample point 10) |
| 128 124 145 | (sample point 11) |
| 127 125 150 | (sample point 12) |
| 128 125 148 | (sample point 13) |
| 128 127 142 | (sample point 14) |
| 127 127 133 | (sample point 15) |
| 127 127 128 | (sample point 16) |
| 127 126 128 | (sample point 17) |
| 128 127 128 | (sample point 18) |
| 126 126 128 | (sample point 19) |
| 128 127 128 | (sample point 20) |
| 127 126 128 | (sample point 21) |
| 127 127 128 | (sample point 22) |
| 128 127 128 | (sample point 23) |
| 127 127 128 | (sample point 24, first impact ends, there are six bits between the impacts to show the number of sample points and time in the following impact) |

Appendix D

The programming codes for Oscilloscope

REG 0,MSC TRACE,BGN 0

REG 0,MSC TRACE,END 3500

REG 0,MSC TRACE,CNT 5

REG 0,MSC TRACE,DATA_TYPE DECIMAL

REG 0,MSC TRACE,DAT ?

Appendix E

This programme was used to calibrate the output of an accelerometer and Oscilloscope, to calculate the peak acceleration, duration, and velocity change of each impact pulse. The results from different separate data files then were put into one resultant print-ready file.

```

program impulse;
var inf, outf :text; {files of text}
    filename, outname : string;
    d1 : char;
    i, j, k, d2, d3, val1, val2, val3, val4, val5: integer;
    value, x, vc, maxaccel, gs, accel, time: real;
label 4;

begin
    writeln('Calculate the Acceleration, Duration, and
            Velocity Change');
    writeln('and create a .PRN file.....');

    write('Name of input file : '); readln(filename);
    write('Name of output file :'); readln(outname);
    if filename <> '' then begin
        assign(inf, filename+'.dat');
        {$I-} reset(inf); {$I+}
        if ioresult <> 0 then
            begin
                writeln('Couldn't find "',filename,'"');

```

```

        halt(1)
    end;
end;
if outname <> '' then begin
    assign(outf, outname + '.prn');
    rewrite(outf);
    writeln('Duration    Acceleration    Velocity
            change');
    writeln(outf, 'Duration    Acceleration    Velocity
            change');
if outname = '' then begin
    writeln('Give the Name of output file please!');
    write('Name of output file :'); readln(outname);
    if outname <> '' then begin
        assign(outf, outname + '.prn');
        rewrite(outf);
        writeln('Duration    Acceleration    Velocity
                change');
        writeln(outf, 'Duration    Acceleration
                Velocity change');
    end;
end;
repeat
    { Read in label, count and first 3 numbers}
    for i := 1 to 4 do read (inf, d1);
    read (inf, d2 , d3);

    j:= 0;
    i:= 0;

```

```
maxaccel:=0;
vc:=0;

for k := 1 to 140 do begin
  i:=i+1;
  read (inf, val1, val2, val3, val4, val5);
  gs := (val1+val2+val3+val4+val5) / 5;

  if round(gs) >= d3 then begin
    j:=j+1;
  end;

  if round(gs) < d3 then begin
    accel:=(gs-d3)*(-1)*1*20/32;
    vc:=vc+accel*9.81*0.061/1000;
    time:=(i-j)*5*0.0122;
  end;

  if accel > maxaccel then maxaccel:=accel;
end;

writeln(time:8:2, maxaccel:17:2, vc:20:2);
writeln(outf, time:8:2, maxaccel:17:2, vc:19:3);

close(inf);
writeln('Calculate next file or enter to stop');
write('Name of file : '); readln(filename);
if filename = '' then goto 4;
assign(inf, filename+'.dat');
```

```
{I-} reset(inf); {I+}  
  if ioresult <> 0 then  
    begin  
      writeln('Couldn't find ',filename,'');  
      close(outf);  
      halt(1)  
    end;  
  until filename=' '  
end;  
4:  
close(outf);  
end.
```

Appendix F

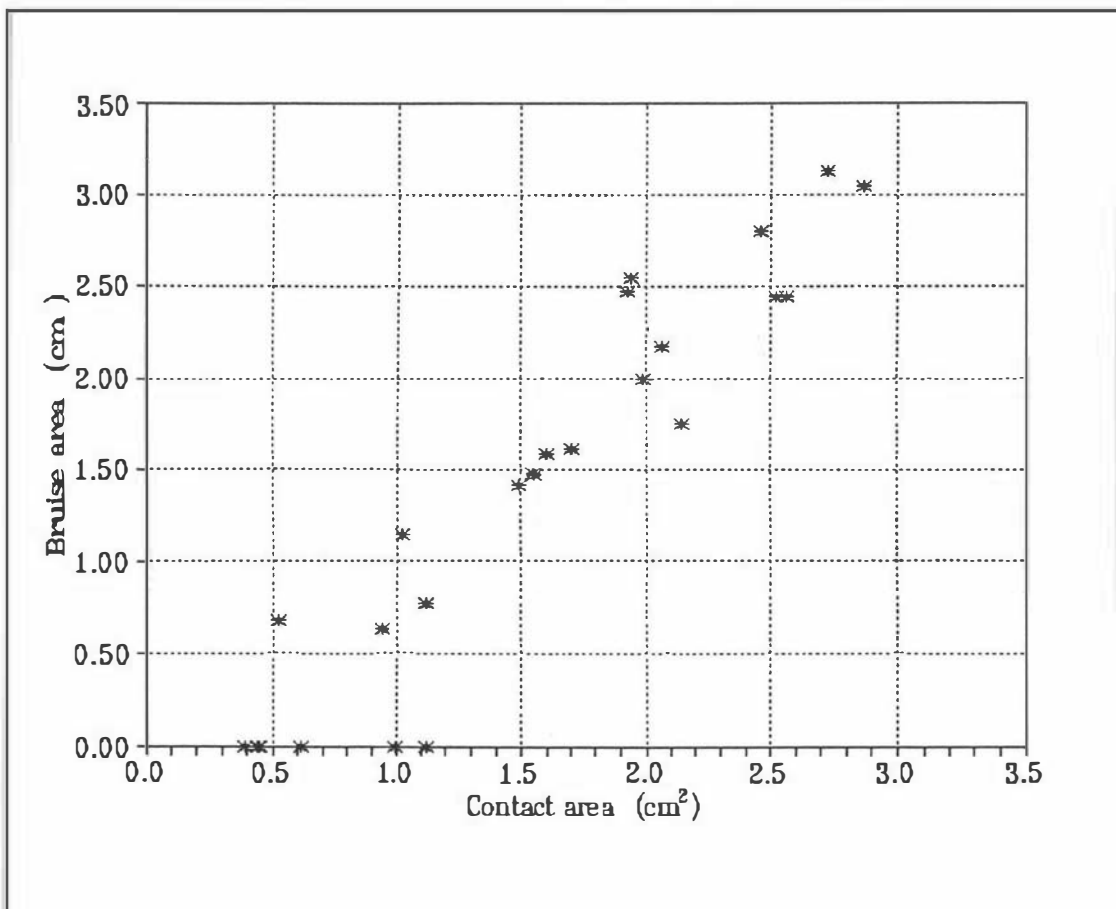

Figure F1 Largest bruise area on either of two colliding apples plotted against contact area for Granny Smith apples

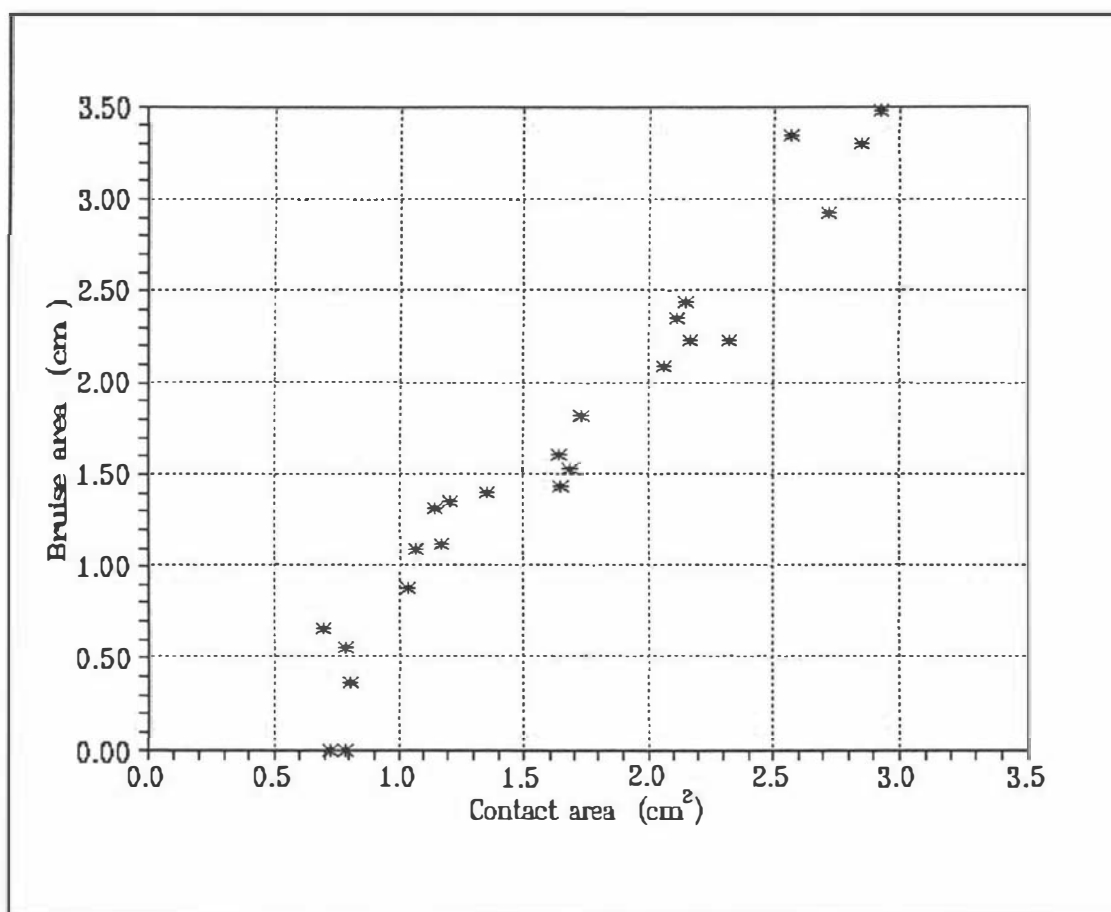

Figure F2 Largest bruise area on either of two colliding apples plotted against contact area for Gala apples

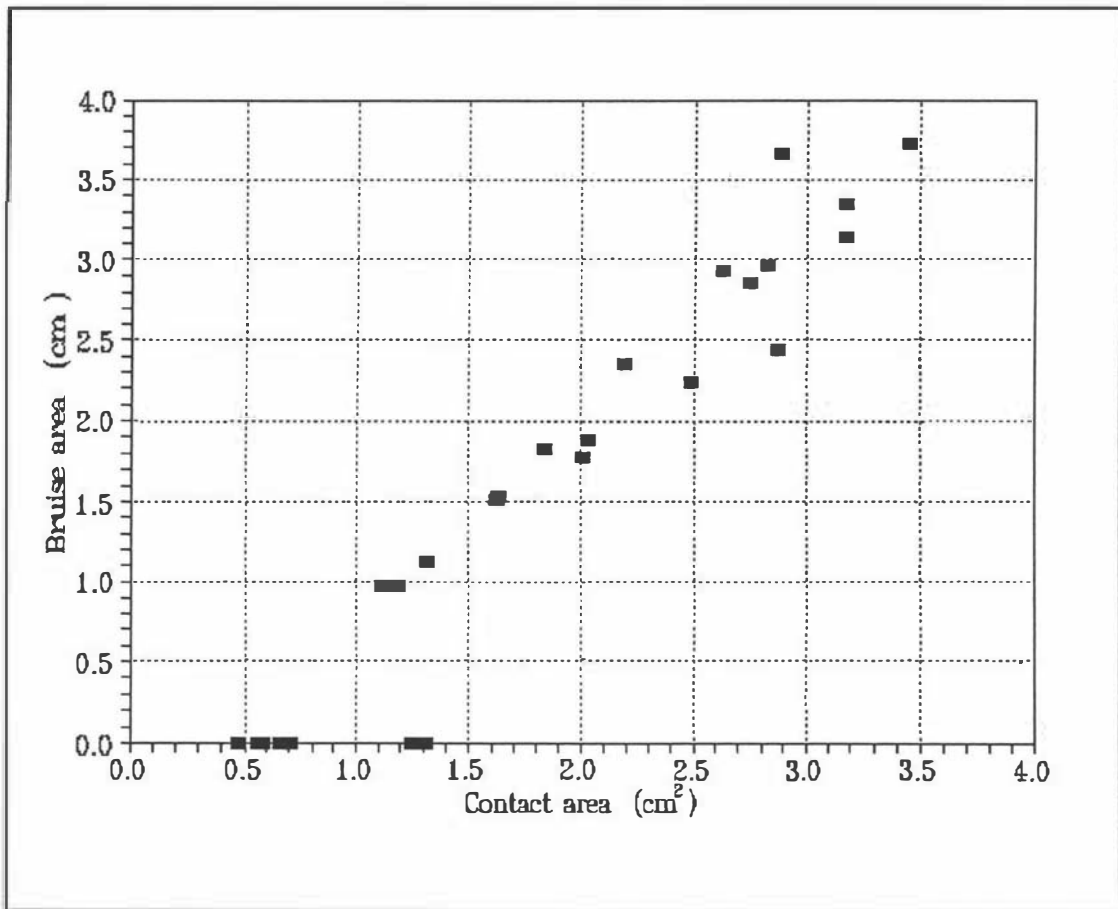

Figure F3 Largest bruise area on either of two colliding apples plotted against contact area for Fuji apples

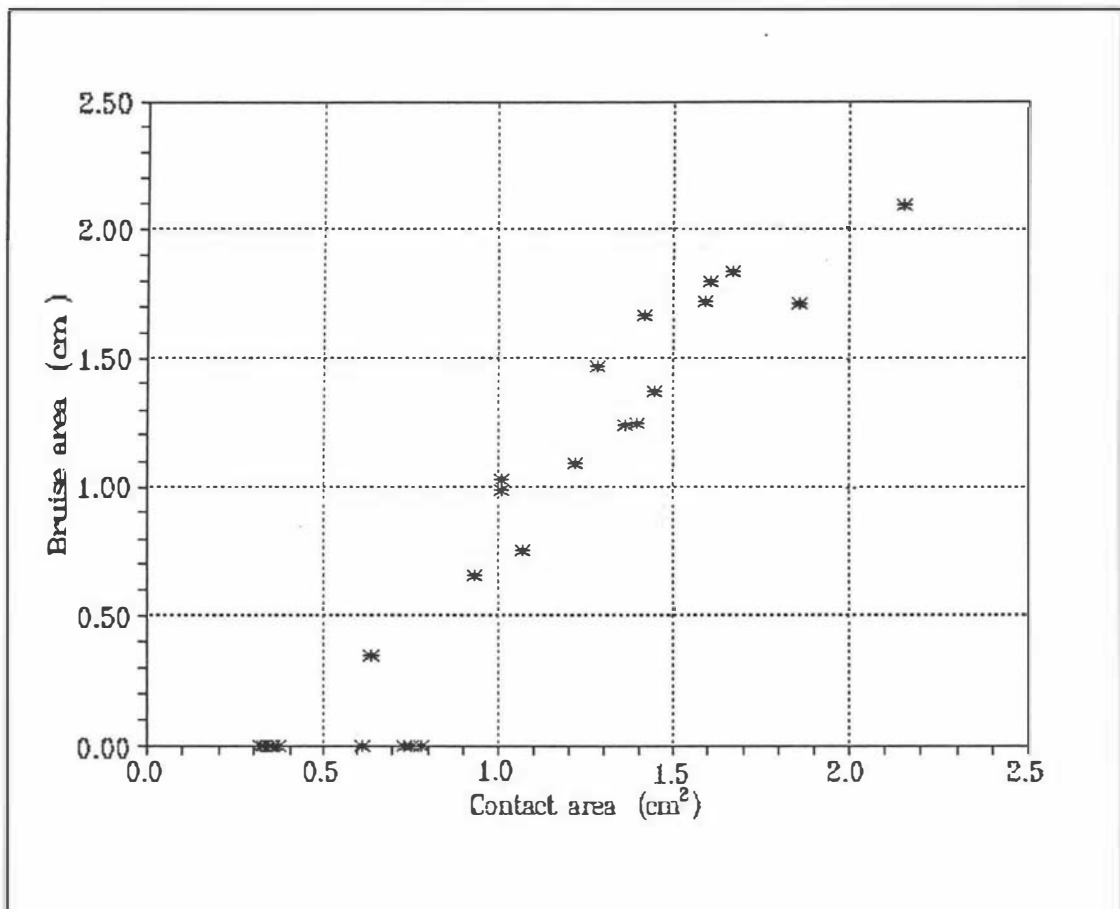

Figure F4 Largest bruise area on either of two colliding apples plotted against contact area for Braeburn apples