

Copyright is owned by the Author of the thesis. Permission is given for a copy to be downloaded by an individual for the purpose of research and private study only. The thesis may not be reproduced elsewhere without the permission of the Author.

WATER STRESS AND APPLE FRUIT QUALITY

A thesis presented in partial
fulfilment of the requirements for
the degree of
Master of Horticultural Science
at

Massey University
Palmerston North
New Zealand

MAPASEKA MOREMONG

1992

ABSTRACT

Regulated Deficit Irrigation (RDI) has been used successfully in dry climates to control vegetative growth of fruit trees during the early part of the growing season without seriously disadvantaging fruit growth or quality. This project was undertaken as part of a study to investigate the feasibility and practicality of using the RDI concept in a humid fruit growing environment using Royal Gala apple trees.

Treatments consisted of a lucerne cover crop, black polyethylene undertree covers and a within-row herbicide strip which is the normal commercial practice in New Zealand orchards. A full irrigation treatment (FI) was used on half the experimental trees and an RDI treatment was used on the other half of the trees. The RDI treatment consisted of withholding water until 105 days after full bloom, then using a full irrigation for the remainder of the season.

Integration with depth of the soil moisture content (θ) (measured with a neutron probe) at the commencement of the experiment revealed 230 mm of water was stored in the top 900 mm of soil. Full irrigation resulted in θ increasing, with storage of about 250 mm 83 days after bloom and remaining at this level for the remainder of the season.

The storage in the RDI treatments decreased in a linear manner until 58 days after bloom, after which it remained constant until irrigation was started 105 days after bloom. The lucerne RDI (LRDI) treatment had a lower storage (105 mm) during this constant period than plastic RDI (PRDI), or herbicide (HRDI) treatments which both had a storage of

130 mm. The amount of water in the soil at this time for LRDI and for PRDI/HRDI was 42% and 52% of the total available capacity. Immediately after irrigation commenced on the RDI treatments, profile water storage returned to the values of the FI treatments remaining at these values for the rest of the season.

Removal of water from the soil profile was not uniform. It appeared that lucerne removed moisture from the upper horizons first, before extracting it from the zone below 500 mm.

Leaf water potentials (ψ_e) were lower in RDI treatments, when measured at midday, (but not pre-dawn), than in FI treatments. Leaves from LRDI trees had lower ψ_e values than did leaves from PRDI and HRDI trees.

Rate of fruit growth was reduced in all RDI treatments during the early part of the season, but returned to the same value as FI fruit once irrigation was resumed; except for LRDI fruit which did not attain the same growth rate of FI fruit. There were less large fruit and more small fruit from LRDI treatments than from other treatments where no significant effects on fruit size were measured. Fruit from RDI treatments were firmer, less mature and contained more soluble solids at harvest than FI fruit; some of these differences were maintained through 12 weeks storage at 4°C. There was no consistent effect of irrigation or cover treatment on fruit colour, mineral content or disease incidence at harvest or after storage.

Vegetative growth, measured as pruning weights and the increment in trunk diameter, was significantly reduced by RDI treatments with LRDI causing the greatest reduction in

pruning weight and PRDI inducing the smallest trunk diameter increase.

The combined lucerne cover crop and RDI treatment was the most successful method found for reducing soil moisture in a humid climate. It also resulted in the greatest amount of stress being induced in these trees, reducing both vegetative growth - a desirable effect; but also fruit growth, a commercially undesirable effect. It is suggested that different methods of managing lucerne, or the use of less successful water extracting plants will need to be evaluated before recommending a successful, yet practical method of using the RDI concept in apple orchards growing in humid environments.

ACKNOWLEDGEMENTS

I am greatly indebted to my supervisors, Professor E.W. Hewett and Dr B.E. Clothier who provided helpful guidance in preparing this thesis.

Gratitude is extended to Bruce MacKay for help in statistics and to the staff of Fruit Crop Unit for helping me to carry out this experiment.

Thanks to the New Zealand Vice-Chancellors Committee for granting of a Commonwealth Scholarship and to the Botswana Government for allowing me to come to New Zealand for this study.

Special thanks are extended to my daughter who was also my best friend and kept me company through very difficult situations.

TABLE OF CONTENTS

	<u>Page</u>
ABSTRACT	(i)
ACKNOWLEDGEMENTS	(ii)
CONTENTS	(iii)
LIST OF TABLES	(iv)
LIST OF FIGURES	(v)
CHAPTER 1 INTRODUCTION	2
1.1 INTRODUCTION	
1.2 WATER BALANCE OF THE ROOT ZONE	3
1.3 SOIL WATER AND LEAF WATER POTENTIAL	6
1.3.1 Control of water availability	9
1.4 TIMING IRRIGATION	10
1.5 HISTORY OF RDI	
1.5.1 Phenology of tree and crop growth	14
1.5.2 Differential sensitivity of tissues, organs and processes	15
1.5.3 Effect of reduced irrigation on the effective root volume and root growth	16
1.5.4 Effect of RDI on leaf water potential ψ_l in relation to fruit and vegetative growth	17
1.6 PHYSIOLOGICAL CONSEQUENCES OF WATER STRESS	17
1.6.1 Leaf water potential	17
1.6.2 Vegetative growth	18

1.6.3	Reproductive growth	19
1.6.4	Fruit growth and yield	19
1.7	FRUIT QUALITY	20
1.7.1	Effects of water stress on soluble solids	20
1.7.2	Effect of water stress on fruit colour	21
1.7.3	Effect of water stress on fruit firmness	22
1.7.4	Fruit size	22
1.7.5	Storage life and disorders	23
1.7.6	Effect of water stress on starch index	24
1.8	OBJECTIVES OF THIS STUDY	24
CHAPTER 2	MATERIALS AND METHODS	
2.1	DESCRIPTION OF TREES	27
2.2	SOIL TYPE AND MOISTURE MEASUREMENT	27
2.2.1	Neutron Probe	28
2.2.1.1	Theory	29
2.2.1.2	Methodology	29
2.3	THINNING	30
2.4	PHYSIOLOGICAL MEASUREMENTS	33
2.4.1	Pressure Chamber	33
2.4.1.1	Theory	33
2.4.1.2	Procedure Used	35
2.4.2	Apple fruit growth	35
2.4.3	Pruning	36
2.4.4	Cross sectional area of trunk	36

2.5	LAYOUT OF TREATMENTS	36
2.5.1	Soil management treatments	36
2.6	IRRIGATION STRATEGIES	38
2.7	ORCHARD MANAGEMENT	39
2.8	YIELD	41
2.9	POST-HARVEST	42
2.9.1	Starch Index	42
2.9.2	Penetrometer	45
2.9.3	Refractometer	45
2.9.4	Colour	45
2.9.5	Minerals	46
2.9.6	Data Analysis	46

CHAPTER 3 SOIL MOISTURE RESPONSES

3.1	INTRODUCTION	48
3.2	RESULTS	50
3.2.1	Soil moisture content and profile storage	50
3.2.2	Water content at different depths	53
3.3	DISCUSSION	59

CHAPTER 4 APPLE TREE RESPONSE TO WATER STRESS

4.1	INTRODUCTION	64
4.2	RESULTS	65
4.2.1	Leaf water potential (ψ_l)	65
4.2.2	Fruit growth	68
4.2.3	Trunk diameter	69

4.2.4	Pruning weights	76
4.2.5	Fruit quality	76
4.2.5.1	Firmness	76
4.2.5.2	Soluble solids	76
4.2.5.3	Starch index	79
4.2.5.4	Fruit mineral	79
4.2.5.5	Colour	80
4.2	DISCUSSION	81
CHAPTER 5	CONCLUSION	89
REFERENCES		94

LIST OF TABLES

	<u>Page</u>	
Table 2.1	Number of fruit left on each Royal Gala tree after hand thinning on 01.11.89.	32
Table 2.2	Application of herbicides.	38
Table 2.3	Weather and irrigation on Royal Gala trees.	39
Table 2.4	Fruit sizes and their conversion to weight sizes range from smallest to largest.	41
Table 4.1	Firmness of Royal Gala apples at harvest and after 6 and 12 weeks at 2°C for Full Irrigation and RDI treatments in covers of Plastic, Lucerne and Herbicide.	78
Table 4.2	Soluble solids on Royal Gala fruit at harvest and after 6 and 12 weeks at 0°C, from trees exposed to Full Irrigation and RDI treatments and different ground covers of Herbicide, Plastic and Lucerne.	78
Table 4.3	Starch index in Royal Gala fruit at harvest and after 6 and 12 weeks at 0°C from trees exposed to RDI and Full Irrigation treatments and ground covers of Herbicide, Plastic and Lucerne.	79
Table 4.4	Mineral content of Royal Gala apples from trees exposed to full irrigation and RDI treatments and different ground covers of Herbicide, Plastic and Lucerne.	80
Table 4.5	Ground colour of Royal Gala apples from trees exposed to full irrigation and RDI treatments and different ground covers of Herbicide, Plastic and Lucerne.	81

LIST OF FIGURES

	<u>Page</u>
Figure 1.1	13
Growth of Golden Queen peach and Bartlett pear fruit and extension shoots on mature trees in a typical season, expressed as a percentage of the total growth occurring during a season by that organ.	
Figure 2.1	31
Diagram of a Neutron Probe used for determining soil moisture content in the Royal Gala block.	
Figure 2.2	34
Schematic diagram of pressure bomb used to measure leaf water potential of Royal Gala apple leaves.	
Figure 2.3	44
Starch pattern indices used for obtaining starch scores on Granny Smith apples.	
Figure 3.1	51
Total water storage W during the 1989/90 growing season in the top 900 mm of soil under Royal Gala apple trees which have received full irrigation (FI) or regulated deficit irrigation (RDI) with or without different types of ground cover.	
Figure 3.2	52
Total water stored W during the 1989/90 growing season under Royal Gala apple trees receiving full irrigation throughout the season with or without different types of ground cover.	
Figure 3.3	54
Total water stored W during the 1989/90 growing season under Royal Gala apple trees receiving RDI treatments (no irrigation under 100 dsb) followed by full irrigation with or without different types of ground cover.	
Figure 3.4	56
Soil water content θ at different depths under Royal Gala apple trees exposed to fully irrigated or RDI treatments.	
Figure 3.5	57
Soil water content θ at different depths under Royal Gala apple trees exposed to RDI treatment prior to and after resumption of irrigation.	
Figure 4.1	66
Leaf water potential ψ_1 for Royal Gala apple leaves taken from HFI, HRDI, PFI, PRDI, LFI and LRDI.	
Figure 4.2	71
Fruit diameter (mm) in fully irrigated (FI) and regulated deficit irrigated (RDI) treatments.	

Figure 4.3	Fruit size distribution in HFI (dark hatching) and HRDI (light hatching) treatments for small (198-175), medium ₁ (163-150), medium ₂ (138-125) and large (113-64) Royal Gala apples.	72
Figure 4.4	Fruit size distribution in PFI (dark hatching) and PRDI (light hatching) treatments for small (198-175), medium ₁ (163-150), medium ₂ (138-125) and large (113-64) Royal Gala apples.	73
Figure 4.5	Fruit size distribution in LFI (dark hatching) and LRDI (light hatching) treatments for small (198-175), medium ₁ (163-150), medium ₂ (138-125) and large (113-64) Royal Gala apples.	74
Figure 4.6	Trunk diameter difference on Royal Gala apple trees taken above the stock/scion union. Differences were calculated between records taken in July 1989 and July 1990.	75
Figure 4.7	Pruning weights from HFI (100 H), HRDI (25 H), PFI (100 H), PRDI (25 P), LFI (100 L) and LRDI (25 L) taken in 1990.	77

CHAPTER 1

INTRODUCTION

1.1 INTRODUCTION

Water constitutes one of the most important constraints to increasing food production worldwide; and in some parts of the world irrigation is the only way to make sure any food can be produced. The amount and rate of water uptake depends on the ability of the roots to absorb water from the soil with which they are in contact, as well as the ability of the soil to supply and transmit water towards the roots at a rate sufficient to meet transpirational requirements (Hillel, 1980). These depend on properties of the plant such as its rooting density, rooting depth, and rate of root extension, as well as upon the physiological ability of the plant to continue drawing water from the soil at the rate needed to avoid wilting, whilst maintaining its vital functions. The properties of the soil, such as its hydraulic conductivity, diffusivity, matric suction and their relationship to soil water content are also important. Soil water uptake by plants is also due to a considerable extent on the meteorological conditions which dictate the rate at which the plant is required to transpire and hence the rate at which it must extract water from the soil in order to maintain its own water status.

From a physical point of view, evapotranspiration can be viewed as a continuous stream of water flowing from a periodically replenished source of limited capacity and variable potential, namely the reservoir of soil moisture, to a sink of virtually-unlimited capacity - the atmosphere. As long as the rate of root uptake of soil moisture balances the rate of canopy loss by transpiration, the stream continues unabated while the plant remains fully hydrated. The moment the uptake rate falls below transpiration, the plant itself begins to lose moisture. This imbalance cannot continue for any length of time without resulting in loss of turgidity and wilting of the plant.

The concept of potential transpiration (Penman, 1949) is an attempt to characterise the evaporative flux extracted from a stand of plants fully covering the ground surface when the supply of soil water is not limiting. It is the meteorological conditions rather than soil or plant conditions which exercise the greatest influence on the transpiration rate as long as the soil is wet enough. However, as soil wetness is diminished, even though not completely depleted, actual transpiration begins to fall below the potential rate either because the soil cannot supply water fast enough, or because the roots can no longer extract it fast enough to meet the meteorological demand. The point at which this condition is reached depends in a combined way upon the weather, the plants and the soil. The best method to analyse all this in the soil is through the water balance. Irrigation is a means to keep soil wetness high.

1.2 WATER BALANCE OF THE ROOT ZONE

The water balance states that in a given volume of soil (V , m^3), the difference between the amount of water added (W_{in} , m^3) and the amount of water withdrawn (W_{out} , m^3) during a certain period is equal to the change in water content δW during the same period (Hillel, 1982).

$$\delta W = W_{in} - W_{out} \quad 1.1$$

This change results in a change in the volumetric water content of the soil (θ , m^3m^{-3}).

$$\delta W = V\delta\theta \quad 1.2$$

When gains exceed losses, the water-content change is positive, and conversely when losses exceed gains, δW is negative. Rain or irrigation water applied to the land may in some cases infiltrate into the soil as fast as it arrives. In other cases some of the water may pond over the surface. Depending on the slope and microrelief, a portion of this water may exit from the area as surface run-off while the remainder will be stored temporarily as puddles in surface depressions. Of the water infiltrated, some evaporates directly from the soil surface, some is taken up by plants for growth or transpiration, while some may drain downwards beyond the root zone and add to soil moisture storage. Additional water may reach the defined soil volume by run-off from a higher area, or by upward flow from a water table or from wet layers present at some depth. The pertinent volume of depth of soil for which the water balance is computed is determined arbitrarily. From an agricultural or plant ecological point of view, it is generally appropriate to consider the water balance of the root zone per unit area of field. The root zone water balance is expressed in integral form thus:

$$\begin{aligned} \text{Change in storage} &= \text{gains} - \text{losses} \\ \delta S &= (P + I + U) - (R + D + E + T) \end{aligned} \quad 1.3$$

where δS is change in root zone soil moisture storage, δF increment of water incorporated in the plants, P precipitation, I irrigation, U upward capillary flow into the root zone, R run-off, D downward drainage out of the root zone, E direct evaporation from the soil surface, and T transpiration by plants (Hillel, 1982).

The time rate of change in soil moisture storage can be written as follows:

$$ds/dt = (p + i + u) - (r + d + e + t) \quad 1.4$$

where t = time and t_r = transpiration rate. Each of the lowercase letters represents the instantaneous time rate of change of the corresponding integral quantity in equation 1.1. The change in root zone soil moisture storage can be obtained by integrating the change in soil wetness (S) over depth and time as follows:

$$S = \int_0^z \int_0^t \frac{d\theta}{dt} dt dz \quad 1.5$$

where θ is the volumetric soil water content, measured by gravimetric sampling or by means of a neutron probe and z is the lower boundary of the water extraction by roots and is assumed constant with time (Sharma, 1985).

Evapotranspiration from a well-watered field depends primarily on the energy supplied to the surface by solar radiation, which is characteristic for each location and varies little from year to year (Hillel, 1982). $E + T$ are generally designated E_{to} representing the climatic demand for water. Evapotranspiration also depends upon surface roughness and soil thermal properties, characteristics which may vary in time (van Bavel and Hillel, 1976). As a first approximation, and working hypothesis, it is assumed that E_{to} depends entirely on the external climatic inputs and is independent of the transient properties of the field itself (Hillel, 1982).

Actual evapotranspiration, ET_a is generally some fraction of E_{to} depending on the degree and density of plant canopy coverage of the surface, as well as on soil moisture and root distribution. E_{ta} from a well-watered stand of a close growing crop will generally approach E_{to} during the active growing stage, but may fall below it during the early growth stage, prior to fully canopy coverage, and again towards the end of the growing season, as the matured plants begin to dry out (Hillel and Guron, 1973). For the entire season, E_{ta} may

total 60-80% of E_{p} depending on water supply: the drier the soil moisture regime, the lower the actual evapotranspiration.

Another important item of the field-water balance is the drainage out of the root zone. A certain amount of drainage is required for aeration and for leaching out excess salts so as to prevent this accumulation in the root zone.

1.3 SOIL WATER AND LEAF WATER POTENTIAL

The balance between water loss through transpiration, and water uptake via roots, controls the plant water status which is usually related to the plant water deficit (Boyer, 1969).

Water movement through the soil-plant-atmosphere is best treated as a series of interrelated, interdependent processes. Rate of water absorption is affected both by the rate of water loss and by the water balance. Rate of transpiration depends not only on stomatal aperture and atmospheric factors affecting evaporation, but also on the rate of water absorption which is governed by the water balance (Kramer, 1983).

To characterise the soil-plant-atmosphere continuum, it is important to evaluate components of the energy potential of water and the effective potential gradient as it varies along the entire path of water movement. This includes liquid water movement in the soil towards roots, absorption into roots, transport in roots to the stem and through the stem to

leaves, and vapour diffusion through substomatal cavities and stomatal openings to the quiescent boundary air layer in contact with the leaf surface, then through it to the turbulent air layer surrounding the plant and finally transport to the external atmosphere (Kramer, 1983).

The total potential difference between soil moisture and atmospheric humidity can amount to hundreds of bars, and in an arid climate can even exceed 10,000 bars. Of this total, the potential drop in the soil towards the roots may vary from a fraction of a bar to several bars. Except where the soil is fairly dry, the potential drop in the roots is likely to be somewhat greater than that in the soil (Molz, 1976). The potential drop in the xylem from roots to leaves will generally not exceed a few bars. Thus the major portion of the overall potential difference in the soil plant atmosphere continuum occurs between leaves and the atmosphere (Philip, 1966).

Soil-water potential decreases as soil wetness decreases. The plant-water suction required to extract water from the soil must increase correspondingly. The soil will deliver water to roots as long as the water suction in the latter is maintained greater than in the former. As a root extracts water from the soil in contact with it, the suction in the contact zone may increase and tend to equal the root suction.

As long as the plant does not wilt, and as long as the influx of radiation and heat to the canopy results only in a change of phase for the water, it is possible to assume steady-state flow through the plant. This means that the transpiration rate is equal to the plant transport and that both are equal to the soil water uptake rate (q):

$$q = \delta\Phi_1/R_1 = \delta\Phi_2/R_2 = \delta\Phi_3/R_3 = \delta\Phi_4/R_4 \quad 1.6$$

where Φ_1 is the potential drop in the soil towards the roots, Φ_2 the potential drop between the soil and root xylem, Φ_3 the potential drop in the plant to the leaves, and Φ_4 the potential drop between the leaves and the atmosphere, and R's are resistances, in the respective zones.

The suction difference between soil and root ($\delta\phi_1$) needed to maintain a steady flow rate depends on conductivity K and the flow rate q, which is the water-extraction rate required of the root by the transpiration process. When soil water suction is low and conductivity high, $\delta\phi$ is small and the suction in the root will not differ greatly from the suction in the soil. When soil-water suction increases, and soil conductivity decreases, the suction difference needed to maintain the same flow rate must increase correspondingly. As long as the transpiration rate required of the plant is not too high, and as long as the hydraulic conductivity of the soil is adequate and the density of the roots is sufficient, the plant can extract water from the soil at the rate needed to maintain normal activity. However, the moment the rate of extraction drops below the rate of transpiration the plant loses water, and if it cannot adjust its root-water suction or its root density so as to increase the rate of soil-water uptake, the plant may suffer from loss of turgor and be unable to grow normally.

Assuming that wilting occurs at a certain limiting value of plant water suction, it is possible to estimate the dependence of average soil wetness at which wilting occurs upon the transpiration rate (Gardner, 1960).

1.3.1 Control of water availability

McAuliffe (1985) pointed out that in arid regions, the entire water requirement is provided by the irrigation system, and root growth approximately follows the pattern of soil water distribution. In areas such as New Zealand, where rainfall supplements irrigation, plant root distribution is less likely to reflect soil water content.

Mature vines of kiwifruit have an extensive pattern of rooting (Clothier et al., 1987). In mature apple tree, Rahardjo (1989) in New Zealand found the highest root density occurred in 2-3 m radius from the tree due to overlapping roots from adjacent trees. Roots had extended beyond 1500 mm depth, showing extensive and vigorous vegetative growth, as defined by Chalmers (1989). It can therefore be assumed that management orientated to restrict root growth might be expected to reduce tree vigour.

One of the methods used to control soil water availability is the manipulation of soil water content, by partial wetting of soil using irrigation management (Bresler, 1977). Cultural practices associated with management of ground surface, such as cover crop, weed control and mulching, can have great influence on soil water availability as well as affecting development of the root system through effects on volume of soil which may be utilised by roots (Fochessatti, 1986).

Plastic films of different thickness and colours have been used. Mulching with plastic film covers the soil for a long time, preventing weed growth, loss of heat and water, and erosion. Bacon (1974) found that black plastic mulching on apple trees prevented evaporation

and retained soil moisture. Similar results were reported by Mage (1982) while comparing plastic cover with permanent grass sod under apple trees.

Another method to limit water availability to fruit trees is to plant a competing crop between trees or rows. Lucerne is a deep-rooted perennial crop which is known to be highly efficient at extracting soil moisture.

Hayman and McBride (1984) compared pasture and lucerne behaviour under irrigation with the following results:

- (a) Lucerne demanded less frequent irrigation than pasture. Due to its deep tap root, lucerne was able to recover water from irrigation that percolated beyond the reach of pasture.
- (b) Lucerne transpired at a higher rate than pasture plants which indicated that in a soil with high water content, lucerne used water at a faster rate.

The use of grass as ground cover to control peach shoot and root growth has been shown to be useful in controlling root growth (Glenn and Welker, 1991). No published work is available to indicate the usefulness of such a competing crop on apple trees.

1.4 TIMING IRRIGATION

Importance of proper timing of irrigation application has been well researched (Rawitz, 1969; Acevedo et al., 1971; Hillel and Guron, 1973; Al-Ani and Bierhuizen, 1971; Garnier

and Berger, 1987). Timing of irrigation has to be adjusted to soil water depletion according to crop requirements which vary with evaporative demand, root depth, size of the soil reservoir and the water holding capacity of the soil (Clothier et al., 1987).

When the soil dries, water uptake by plants becomes difficult (Hanan, 1972). If during drying, evaporative demand is high, the plant responds by reducing transpiration in order to maintain tissue hydration (Garnier and Berger, 1987). Denmead and Shaw (1962) showed that high transpiration rate depleted soil water rapidly, and increased the resistances to water movement. Vermeiren and Jobling (1984) recommended irrigation should be applied as often as required to maintain soil water potential at a level that allows maximum transpiration under local atmospheric conditions.

One method of determining the interval between irrigation is to start watering when a given level of water deficit or evaporation has been reached. Campbell and Campbell (1982) have described a procedure to set what they called the "full" and "refill" points in the soil.

Field capacity can be determined for the particular soil and Campbell and Campbell (1982) recommended the refill point be set at the minimum value of soil water content (θ) that allows the water potential and resistance to water flow from roots to transpiring surfaces to be negligible compared with the other resistances. This means that if soil water content is monitored, it is necessary to convert the value to water potential. This may be done using release curve or by simultaneous measurement of soil water potential (Hanks and Ashcroft, 1980). For practical purposes soil water potential is difficult to determine, therefore it is

recommended that soil water content be monitored and irrigation be set somewhere between the full and the refill points following a record-keeping scheme (Jensen et al., 1970).

Doorenbos and Pruitt (1977) devised an irrigation scheme based on field water balance to be used under any conditions for sprinkler irrigation. Water available for the crop W_e is calculated from the equation:

$$W_e = W_b + P_e + G_e = ET \text{ crop mm/month} \quad 1.7$$

where, W_b = initial soil water stored

P_e = rainfall

G_e = ground water depth

Tables were provided with values for rooting depth, fraction of water available and readily available soil water for different crops and soils.

Buss (1989) proposed a technique to schedule irrigation specifically designed for permanent horticultural plantings. In this technique the readily available water was defined as the volumetric soil water content which could be held between a matric potential of

-0.008 MPa and -0.04 MPa. To determine the timing of irrigation, the total soil water content within the root zone was divided into three stages based on the rate at which soil water content changed in the drying cycle as follows:

- (a) saturation and drainage
- (b) readily available water, and

(c) decrease in readily available water.

Changes in stage (a) were attributed to drainage and evaporation, while in the other two stages were due to ET. The soil water content left in the root zone, when the soil was fully wet was called the drainage upper limit, and the boundary between stage b and c was called the lower limit of plant available water, below which the plant experiences induced stress, following the definitions of Ritchie (1981).

It was Mitchell et al. (1984) who brought the whole idea of irrigation timing in fruit crops to rest. By associating irrigation timing with the physiological development of fruit and the different times at which fruit and vegetative growth maximally occur in peach and pear (Chalmers, 1989), irrigation could be timed to coincide with the period of maximum fruit growth (Figure 1.1).

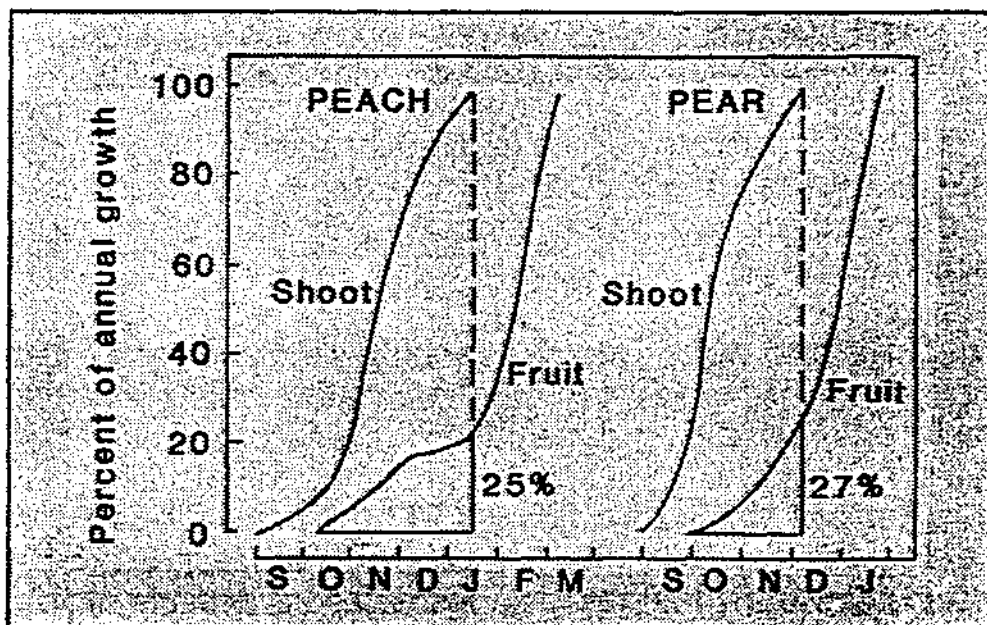

Fig. 1.1 Growth of Golden Queen peach and Bartlett pear fruit and extension shoots on mature trees in a typical season, expressed as a percentage of the total growth occurring during a season by that organ. (Chalmers, 1989).

In an attempt to define requirements for peaches, Chalmers et al. (1981) analysed strategies for irrigation of fruit crops. They defined a system of low irrigation frequency as being adapted to low root density and large root volume. This system was considered more suitable to a relatively low level of management, plentiful water supply and low tree density. Trees grown under such systems were expected to be large, late in bearing and required a high volume of water for irrigation, such as flood or sprinkler. A second system was defined for trees with high root density and small root volume. The latter system was expected to produce smaller trees and be more adapted to higher density plantings (Chalmers, 1989).

1.5 HISTORY OF RDI

With the introduction of new understanding, better equipment and systems now available to irrigate crops, scientists were encouraged to explore more complex options for irrigation management. The major reasons for initiating work on Regulated Deficit Irrigation (RDI) was the need to regulate vegetative growth. This represented a major shift in approach for previously irrigation was used simply to alleviate all water stress throughout the growing period. If vegetative growth could be controlled by strategies manipulation of plant ψ_1 , then it should be possible to control tree size and avoid shading of fruits on the tree, direct photoassimilates to fruit rather than shoots thus increasing fruit size and maybe fruit quality through improved light.

The importance of controlling vegetative growth had been proved by the amount of work that had been devoted to this aspect through dwarfing rootstocks and scion varieties

(that would not give rise to small trees) development of chemical growth inhibitors, summer and winter pruning and tree spacing research.

1.5.1 Phenology of tree and crop growth

Phenological separation of periods during which tissues and organs are actively growing presented one opportunity to inhibit an organ, tissue or process without seriously affecting others. Most events in plant development are seasonal and periodic and would only be sensitive to reduced water potential (ψ_1), during active periods. Periods can therefore be identified during a season when low ψ_1 would affect one process but not others when water supply was reduced to lower ψ_1 and turgor of leaves.

At the beginning of the growing season, fruit development follows shoot development. In terms of assimilate demand there is a significant separation between the early active periods of vegetative growth and fruit growth. After commencing slowly compared to vegetative growth, fruit enter a period of more rapid growth which usually accelerates substantially close to harvest (Chalmers, 1989). After maturity, fruit growth stops, but vegetative growth continues until late in the season. The marked separation of phenologies of fruit and vegetative growth allow targeting vegetative growth with reduced ψ_1 in order to reduce it (Fig. 1.1).

1.5.2 Differential sensitivity of tissues, organs and processes

As the plant ψ_1 decreases with decreasing water availability, organs, tissues and

processes will be affected differently depending upon the sensitivity of the process to plant ψ_1 .

Cells expand following uptake of solutes and have increased cell wall elasticity when they absorb water to restore the balance between the turgor potential of the cell and the vegetative pressure exerted by the combined resistances to stretching, of the cell wall. For this reason cell expansion is very sensitive to reduced plant ψ_1 , making both vegetative and fruit growth extremely sensitive to reduced ψ_1 . Fruit cells expand by a similar mechanism, but because they are strong solute sinks they can attract water more strongly. Growth by root tissues has been shown to tolerate lower ψ_1 than shoot growth (Greacen and Oh, 1972). Photosynthesis and translocation are also less sensitive to reduced ψ_1 than cell expansion in vegetative tissues (Hsiao, 1973). This means that vegetative growth of shoots is reduced at ψ_1 that still allow channelling of photoassimilate to fruit; photosynthesis is inhibited by lower ψ_1 . Thus vegetative growth is more sensitive to reduced ψ_1 than fruit growth.

1.5.3 Effect of reduced irrigation on the effective root volume and root growth

It has been demonstrated that root growth can be inhibited by limiting the root volume of plants (Richards and Rowe, 1977). This also results in an increased ratio of fruit growth to vegetative growth per unit tree size. In arid climates wetting patterns resulting from different methods of water application has been used to alter the root volume of peach trees. Smaller root volumes produced with drip irrigation, resulted in less vigorous, more fruitful trees (Mitchell and Chalmers, 1983), than more vigorous trees produced under sprinkler or flood irrigation.

1.5.4 Effect of RDI on leaf water potential ψ_l in relation to fruit and vegetative growth

Chalmers et al. (1986) showed that leaf ψ_l was reduced by RDI treatment, as compared to fully-irrigated trees. Results of that study confirmed that vegetative growth was more sensitive to reduced plant ψ_l than fruit growth in peaches.

Leaf ψ_l decreased when RDI began, and remained significantly lower than fully-irrigated trees. Fruit growth increased in response to the improved water status on RDI trees when full irrigation was re-applied, and exceeded the rate of growth of control fruit. After full irrigation was restored, fruit growth was strongly stimulated, while leaf ψ_l on RDI trees increased to significantly exceed that measured on control trees.

1.6 PHYSIOLOGICAL CONSEQUENCES OF WATER STRESS

1.6.1 Leaf water potential

For a long time leaf water potential (ψ_l) has been accepted as a measurement of plant water status (Barrs, 1968; Boyer, 1967; Hsiao et al., 1976). Smart and Barrs (1973) explained that the shape of the diurnal ψ_l pattern is similar between different perennial horticultural species.

Goode and Higgs (1973) studying water potential and its component osmotic and

pressure potentials in apple leaves of irrigated and non-irrigated trees obtained a considerable diurnal change in leaf water potential from 0.1-0.2 MPa before sunrise to 1.5-2.5 MPa after midday, even when the soil tension was low.

The diurnal pattern of leaf water potential obtained by Olsson and Milthorpe (1983) in peach trees reached maximum daily values after sunrise, which did not change markedly during the drying cycle. Minimum values were obtained in the early afternoon and more closely reflected the decrease in soil water potential as drying progressed.

1.6.2 Vegetative growth

Goode and Ingram (1971) studying growth of apple trees under different irrigation regimes, found that in deficit treatments trunk growth rate was not affected during the first season, but appeared affected in successive seasons. However, an effect on shoot growth occurred in the first season. In the long term, the most marked effect was on shoot number rather than on shoot elongation. Assaf et al. (1974, 1975) obtained low shoot and trunk growth in dry irrigation treatments.

In irrigation trials on avocado trees, Lahow and Kalmar (1972, 1982) found that a 28% reduction in annual water application led to 25% reduction in trunk growth, with only an 8% decrease in fruit size.

Mitchell et al., (1984) showed that RDI slowed trunk growth, shortened branch elongation and reduced weight on pruned wood on pears.

1.6.3 Reproductive growth

Hanan (1972) found water stress caused serious effects on bud initiation, formation and maturation, while Chalmers et al. (1981) reported that fruit set was reduced on peaches and pears by water stress, but increased per unit tree in RDI treated trees.

1.6.4 Fruit growth and yield

Hilgeman et al., (1959) reported that water stress should be avoided during blossom and fruit set and also during the second stage of citrus fruit growth, since rates of fruit growth and final size may be diminished. Hilgeman (1972) reported that fruit from citrus trees irrigated both sides grew faster than trees irrigated on alternate sides.

The response of apple trees to different soil moisture conditions was studied by Goode and Ingram (1971). They obtained a higher yield in irrigated apple trees than in non-irrigated trees. Assaf et al. (1974) found a linear correlation between the percentage of apple fruit with diameter greater than 6.5 cm and number of days in which the 0-60 cm layer of soil was subjected to less than 30% available water during the main period of fruit growth. They emphasised the importance of frequent irrigation to maintain the available water well above 30% in the top soil layer in order to obtain maximum fruit size.

Chalmers et al. (1981), using RDI, obtained an increase in fruit size and yield of peaches. Beukes and Weber (1982) found that the optimum sequence of water levels necessary to optimise yield on apples was one which indicated a deficit during the first and

fourth phenological phases and the highest water level in the third phenological phase.

Lotter et al. (1985) evaluated the effects of different levels of total soil water on fruit size and yield of apple trees. The treatments were also applied in different phenological phases. Negative effects on yield were obtained when water stress was applied in phase 2 and 3, but no adverse effects resulted when stress was applied during phase 1 to 4. The apparent contradiction between these and former results lies in differences between the stage of physiological development defined by arbitrary stages of phenological development.

Goodwin and Jerie (1989) obtained a positive effect on yield of grapes with more bunches per vine on RDI than full irrigation.

1.7 FRUIT QUALITY

1.7.1 Effects of water stress on soluble solids

Assaf and Braudo, (1975) evaluated the effect of six irrigation regimes on quality of apples. At harvest, fruit from dry treatments had the highest total soluble solids (TSS), whereas fruit from extreme wet treatments had the lowest TSS. Differences among the rest of the treatments were not significant. Guelfat'Reich et al. (1974) obtained the highest TSS at harvest and during storage, and the best shelf life in those treatments which were irrigated two weeks after soil water content reached permanent wilting point in apples. Fruit from low soil moisture content treatments also showed the lowest acid content, but these fruit were of

smaller size and therefore of reduced marketability than fruit from full irrigation treatments.

Guelfat'Reich and Ben-Arie (1979) studied the effects of frequency of irrigation in addition to effects of trickle or sprinkler irrigation systems on fruit quality of a diverse range of fruits. In sprinkler and trickle experiments with apples, they obtained TSS contents which were significantly higher when the amount of irrigation was reduced.

Evaluation of the effects of RDI on apple quality by Irving and Drost (1987) resulted in higher TSS in fruit from all RDI trees than in control trees which had received full irrigation.

1.7.2 Effect of water stress on fruit colour

Jackson et al. (1971, 1977a, 1977b) found that shading individual fruit and entire bearing trees affected red colour development, size and storage quality in apple. If vegetative growth is controlled through RDI improved colour might be expected. Morgan et al. (1984) pointed out that the apple cultivar 'Gala' attracts more returns if red blush development is maximised. They found that summer pruning increased the percentage of red blush and fruit weight, but did not affect background colour.

In Sander's study when irrigation was terminated early at 30% red fruit in tomatoes, colour values decreased more in variety VF145-B7879 than in variety UC82-B before harvest. Colour increased with more irrigation (Sanders et al., 1989). Morris et al., (1962) reported that sensory evaluation of the canned samples of peaches indicated that both all

season and final swell irrigation produced a more-acceptable canned product, especially in terms of taste and colour.

1.7.3 Effect of water stress on fruit firmness

In their experiments with apples and pears, Hendrickson and Veihmeyer (1942) obtained softer fruit from wet plots than from moisture stressed plots. But provided the stress was too not severe, differences evened out during storage and ripening. Guelfat'Reich et al. (1974) and Assaf and Braudo, (1975), in experiments with different irrigation regimes in apple, found no consistent differences in fruit firmness except in the driest treatment in which fruit were significantly firmer than in the other treatments at harvest and during subsequent shelf life on apple.

Degree of apple fruit firmness seemed more related to fruit size than to irrigation in reports by Amen et al., (1983). While small fruit exhibited the highest firmness, no differences between irrigated and non-irrigated fruit were detected.

Erf and Proctor (1987), comparing apple trees with under tree tent-like canopy covers and those receiving natural rainfall, obtained fewer fruit, lower total fruit weight, higher TSS and firmer fruit from trees with covers.

1.7.4 Fruit size

Reduced growth due to soil moisture deficit during the season results in reduced fruit

growth in apples (Goode, 1972; Proesbing, 1970). Guelfat'Reich and Ben-Arie (1979) examined the effect of trickle and sprinkler irrigation on fruit quality and found size reduction in apples, grapes, apricots and pears when the irrigation was reduced three weeks before harvest.

Mitchell and Chalmers (1982) showed that RDI significantly and positively affected fruit size. Subjecting avocado trees to a 30% reduction in quantity of water applied resulted in more fruit per tree, greater yield, and largest individual fruit size (Adato and Levinson, 1988).

1.7.5 Storage life and disorders

Inferior keeping quality in storage of apple fruit was recorded following irrigation trials by Guelfat'Reich et al. (1974). The occurrence of physiological and pathological disorders such as bitter pit and scald was lower in fruit from drier treatments and very high in wet treatments.

Heavy irrigation was suggested to cause leaching of nutrients from the root zone, which caused a mineral imbalance of fruit or alternatively effects on cell turgor and susceptibility of cell walls to disruption (Guelfat'Reich and Ben-Arie, 1979). Proebsting et al. (1984) working on apple, suggested that irrigation had no effect on storage and that changes in fruit were the same independent of irrigation.

1.7.6 Effect of water stress on starch index

Starch pattern index has been applied to many apple varieties worldwide as a possible maturity index and has been accepted or rejected on the basis of numerous criteria. In New Zealand, Tiller (1934) rejected measurements of starch loss in the variety Cox's Orange Pippin because it did not relate to fruit blush, itself a poor indication of fruit maturity (Smock, 1984), and because of variation within a sample of visually similar fruit. Tiller concluded that "the individual variation may prove so great as to mask the effect of time factor on hydrolysis of starch." Under New Zealand conditions the maturation period of apples can be spread over several weeks leading to substantial variation in time of ripening of apparently uniform fruit (Reid, 1975). A maturity tests should not disguise actual variation if it is present.

1.8 OBJECTIVES OF THIS STUDY

Regulated Deficit Irrigation in arid and semi-arid regions has been sufficiently proven as a management strategy that reduces vegetative growth without reducing fruit growth. Thus expectations and questions arise regarding the possibility of using this technique for a wider range of fruits and environments. In a humid environment such as New Zealand, where high rainfall during winter and early spring saturate the water holding capacity of the soil and spring rains reduce evapotranspiration, the potential for RDI will be reduced. To be successful RDI requires the plant to be exposed to a water deficit in the initial period of rapid vegetative growth when the water demand is low. In this work, it was sought to investigate

alternative soil management techniques which might be suitable to control excess of soil water in the root zone, making the use of RDI feasible in a humid environment. Effects on fruit growth, yield and quality were also investigated. Use of lucerne as a soil extracting cover crop and black plastic covering to prevent water infiltration were investigated.

CHAPTER 2

MATERIALS AND METHODS

2.1 DESCRIPTION OF TREES

The apple trees (*Malus domestica* Borkh. cv 'Royal Gala') on which the experiments were performed were planted in 1985 at a spacing of 4.5 m between the rows and 2 m between the trees. The rootstock used on the trees was MM106.

Pruning has been carried out once every year during the month of July, there being only winter pruning.

2.2 SOIL TYPE AND MOISTURE MEASUREMENT

The soil of this orchard is the Manawatu fine sandy loam, which comprises 50 cm of fine sandy loam, overlying 40 cm of fine sand, with a gravelly coarse sand below 90 cm (Clothier et al., 1977).

The presence of a coarse underlay causes unsaturated drainage cessation at a higher (wetter) pressure potential than would occur if the coarse layer were absent (Clothier, 1976). The conductivity of the gravelly coarse sand falls steeply with decreasing pressure potential. This then serves to limit drainage from the overlying soil which might well be a quite wet water content.

2.2.1 Neutron Probe

2.2.1.1 Theory

The neutron scattering technique is widely used for soil water studies, as the technique can be used to monitor the volumetric soil water content profile in the field without destructive sampling. The principle of the technique is that hydrogen nuclei in the soil water are assumed to be the major soil component reducing the kinetic energy of fast neutrons emitted by the source in the probe. The collisions with the water molecules causes these neutrons to become slow neutrons in the thermal range (Goodspeed, 1981). This occurs when the fast neutrons collide with the hydrogen nuclei of the water in the soil. Energy transfer occurs in the collisions, so that the velocity of the fast neutrons decreases. After about 18 collisions, the fast neutrons become slow or thermalized neutrons (Visvalingam and Tandy, 1972). The density of hydrogen nuclei counted by the detector in the probe is a reflection of the fraction of the soil volume consisting of water.

The measurement can be carried out by lowering the probe down a 50 mm diameter aluminium access tube. The radioactive source emits fast neutrons which pass directly through the tube into the soil. The detector, which is situated near the source in the probe, measures the intensity of the slow neutron 'cloud' in the sphere of influence. The scaler counts the thermalized neutrons detected. The count rate is proportional to the volumetric soil water content (Shirazi and Isobe, 1972). The number of neutrons counted appears on the scaler screen after counting for some period of time. The period of time for counting can be adjusted to 15, 30, 45, 60 or 120 seconds. A 30 second period counting time was used during the experiments described here. The count of slow neutrons, divided by the standard count

taken initially in the shield, can be used to calculate the volumetric soil water content by using a calibration equation (Greacen, 1981). The standard count is a reading taken in the probe's shield which contains a fixed number of hydrogen nuclei. To reduce errors in measurements due to variations in electronic performance, radioactive decay and perhaps to temperature dependence in the electronics, the standard count has to be measured once each day.

Although the technique has many advantages, it has one significant disadvantage. This is that the technique cannot be used to measure soil water content close to the soil surface. The reason for this is that the radius of the sphere of influence, particularly in dry soil, is less than about 200 or 300 mm. Thus at shallow depths some fast neutrons escape through the soil surface and so cannot either be thermalized and counted by the detector, so the soil water content in this layer will be under-estimated. In this experiment the first measurement depth was taken to be 200 mm.

2.2.1.2 Methodology

Neutron probe measurements were taken once a week on the same day at the same time, in the early afternoon around 1 pm - 2 pm. Measurements started from 22 days since bloom (dsb) (30 October 1989) and stopped at 141 dsb (26 February 1990).

The neutron probe's cord was used to lower the device into the access tube situated some 45 cm away from the tree across the row. The process was then repeated for another access tube situated 45 cm from the tree but along the row. Measurements were taken at the

following depths of 20 cm, 40 cm, 60 cm and 80 cm.

Figure 2.1 shows the components of the neutron probe used in this study.

2.3 THINNING

In order to improve on fruit size, thinning is an established commercial practice. Normally the smallest fruits are removed.

Fruitlets were hand-thinned at 40 dsb to reduce fruit load and encourage reasonable size fruit at harvest. Trunk cross sectional area was used as a means of determining the number of fruits to be left on the tree. The average cross sectional area was calculated and a commercial number of 300 fruit per tree allocated to the average tree. Each tree's fruit number was then calculated in comparison to the average tree. All trees were thinned to a fruit density of between 5 and 6 fruit per cm^2 of cross sectional area (Table 2.1).

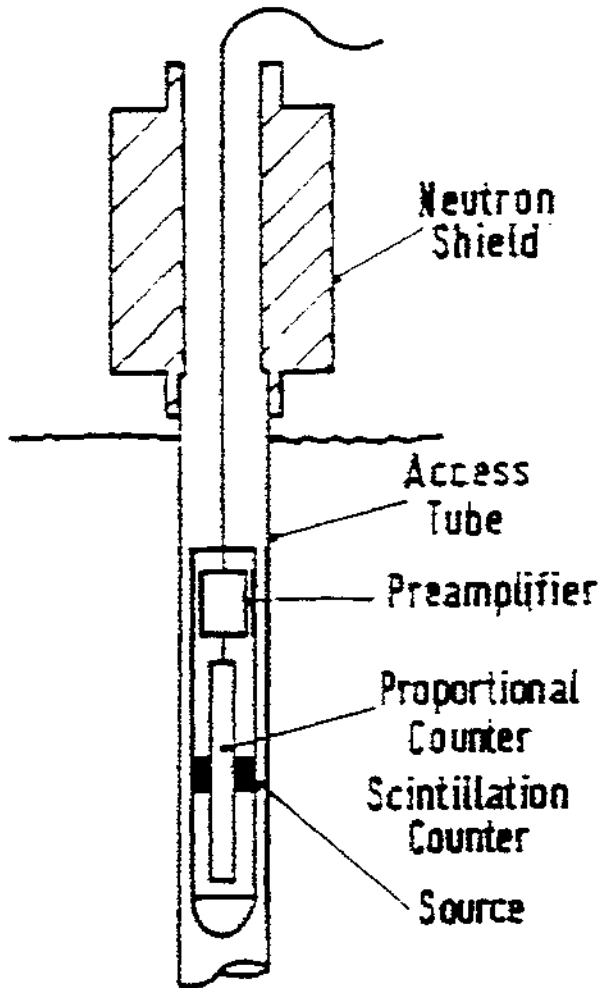

Figure 2.1 Diagram of a Neutron Probe used for determining soil moisture content in the Royal Gala apple block.

Table 2.1 Number of fruit left on each Royal Gala tree after hand thinning on 01.11.89.

Block I	Tree Number	Cross Sectional Area (cm ²)	Number of fruits left on trees
1	4	52.83	296
1	5	29.24	164
1	6	55.44	310
1	9	55.44	310
1	10	46.59	261
1	11	73.93	415
1	14	52.83	296
1	15	47.80	268
1	16	69.42	390
1	19	53.83	302
1	20	37.41	210
1	21	60.85	341
1	24	55.44	311
1	25	60.85	341
1	26	62.24	349
1	29	49.04	275
1	30	39.61	222
1	31	56.77	319
2	4	33.20	186
2	5	37.41	210
2	6	41.87	235
2	9	55.44	310
2	10	50.29	282
2	11	49.04	275
2	14	70.91	398
2	15	67.96	381
2	16	54.13	304
2	19	51.55	289
2	20	55.44	311
2	21	60.85	341
2	24	49.04	275
2	25	52.83	296
2	26	51.55	289
2	29	60.85	341
2	30	62.24	349
2	31	60.85	341

2.4 PHYSIOLOGICAL MEASUREMENTS

2.4.1 Pressure Chamber

This instrument measures leaf water potential which reflects the amount of stress in a plant.

2.4.1.1 Theory

The pressure chamber used in this research (Figure 2.2) was similar to the portable chamber introduced by Waring and Cleary (1967).

The general manner by which the pressure chamber works is as follows. When water is in a blind-ended capillary with wettable walls, such as the xylem vessels in a severed fresh leaf, not only is there a pressure difference across the curved interface, but also across the petiole for a short distance. Water inside the leaf is at a lower pressure than air hence potentials have a negative sign. To measure the original pressure before the leaf was severed, the leaf is placed in a chamber with the cut petiole protruding through a rubber gland. Then a certain pressure of nitrogen gas is applied to the chamber, until water is forced from the mesophyll and observed to refill the xylem (Duniway, 1971). The minimum pressure needed for the exudation of water (xylem sap) from the cut end of the petiole is assumed equal in magnitude to the internal pressure potential of the leaf before it was severed.

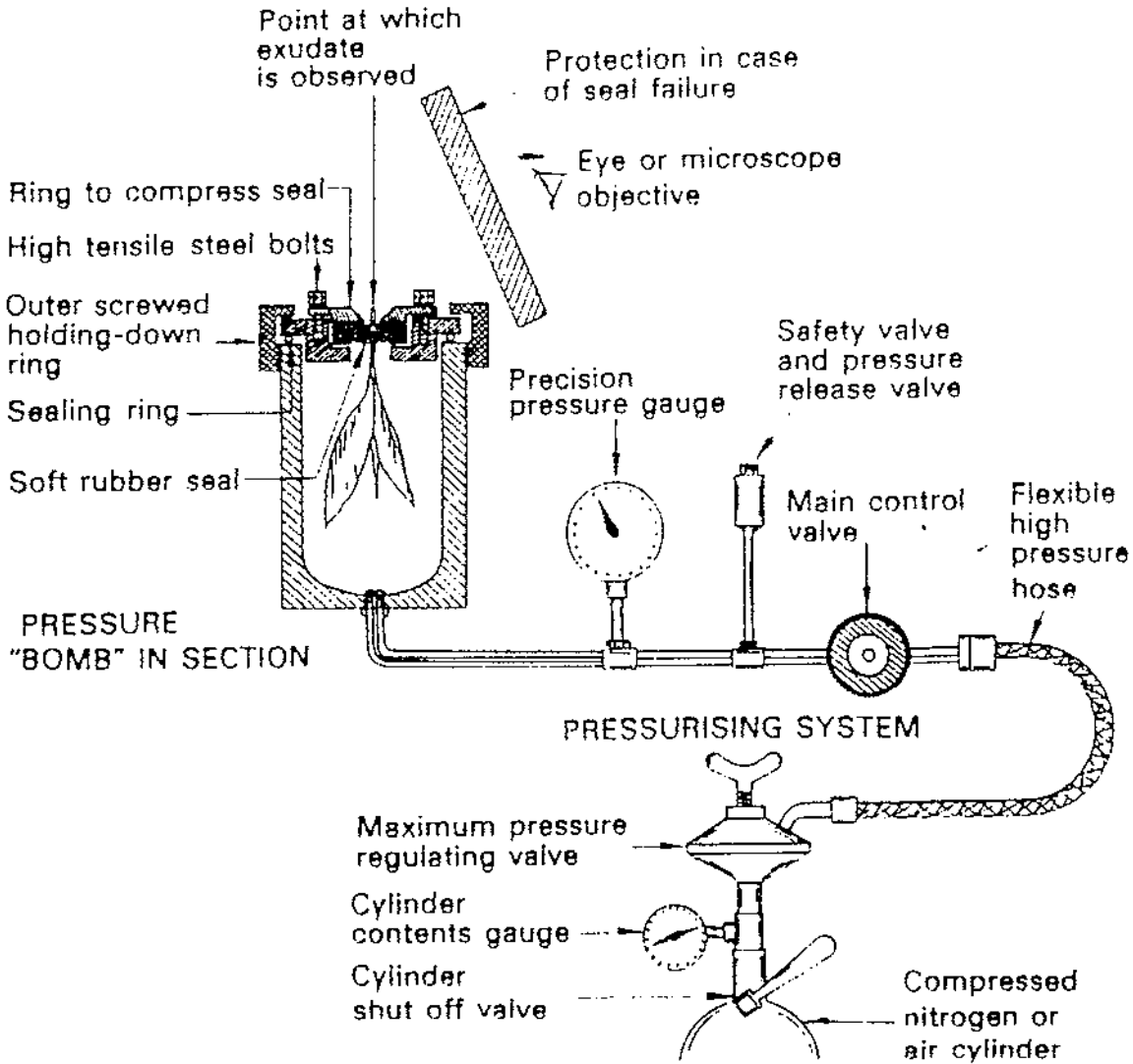

Figure 2.2 Schematic diagram of pressure bomb used to measure leaf water potential of Royal Gala apple leaves.

2.4.1.2 Procedure Used

To determine leaf water potential (ψ_l), two fully expanded mature leaves were chosen from shaded non-fruiting branches located in the outer canopy at a height of 1.5 to 2.4 m above ground.

The pre-dawn ψ_l measurements were made between 1 and 2 am while the midday ψ_l measurements were made between 1-2 pm every Wednesday from 22 days since bloom. Measurements were taken on two leaves per tree making the total number of 6 leaves per plot (12 leaves/treatment).

Each apple leaf was cut and put in a small transparent plastic bag to avoid water loss due to evaporation (Gandar and Tanner, 1976). The cut end of the leaf was quickly inserted through a rubber gland into the chamber top, less than one minute after removal from the tree. The top was affixed then to the chamber body. Subsequently, the chamber was pressurised using nitrogen gas until exudation of xylem sap from the leaf could be seen. The pressure was then recorded. Finally, the bleed-off valve was opened to release the pressure.

2.4.2 **Apple Fruit Growth**

An apple tree suffering water stress may experience detrimental effects, especially reduced apple fruit growth. To monitor any change in fruit growth, weekly measurements were made on each treatment, using a pair of digital calipers. Ten fruit were tagged on each of the three middle trees in each treatment, making a total number of 30 tagged fruit per treatment.

2.4.3 Pruning

Once a year, during the month of July (winter), pruning weights were taken from each tree in each treatment. This was done to monitor differences between the water stressed treatments and the full irrigation treatments.

2.4.4 Cross Sectional Area

In order to detect differences between full irrigation and water stressed trees, trunk circumference was measured on each tree in July 1989 and again in July 1990 and cross sectional area calculated. The measurement was taken about 40 cm from the ground above the rootstock/scion union.

2.5 LAYOUT OF TREATMENTS

2.5.1 Soil management treatments

Soil management treatments were as follows:

- (a) herbicide strip was used as control treatment,
- (b) a permanent sward of lucerne was planted as an under-tree cover, and

- (c) a rain shelter of black heavy grade polythene film directly covering the soil surface.

Treatments were established in April 1987. Lucerne was planted in a 2 m wide strip along the tree rows. A light tree-line bank and centre-row drain was created to prevent water ponding on the plastic surface.

To lay the polythene film, a trench 50 cm deep was cut at 1 m distance from the trees in both sides of each row. Two plastic film sheets 2 m wide were extended along the row, from the tree line towards the trench and buried laterally to cover the wall of the trench. Soil was then packed around the plastic and the trench was refilled with soil. Along the tree line the plastic bands were overlapped and glued. Plots receiving the other treatments were trenched at 1 m from the trees at the same depth as the plastic treatment.

The design of the experiment was a split block trial. Two blocks have been arranged, such that each cover and each irrigation treatment was replicated on each block. Two rows with 30 trees in each were the main blocks. Each experimental main block was split into two subplots, one of which received full irrigation (FI) and one which received regulated deficit irrigation (RDI). Every subplot contained three soil management plots, each one containing five trees. The two end trees on every soil management plot were left as guard trees. The soil management treatments were randomised.

Lucerne was cut twice during the season, once during the middle of December 1989 and once during the middle of January 1990.

To keep weeds out of the bare strips, the following herbicides were applied along the rows: Amatin (Nethabenthiazuron plus Diuron) and Surflan (Oryzalin) which are persistent pre-emergent herbicides, and Preeglone (Paraquat and Diaquat) which is a knockdown desiccant herbicide (Table 2.2).

Table 2.2

Date	Herbicide	Rate of application
24.8.89	Amatin	8 kg ha
	Surflan	4 kg ha
	Preeglone	3 litre/ha
22.12.89	Preeglone	5 litre/ha

2.6 IRRIGATION STRATEGIES

Plants were irrigated using four 8 litre/h Turbo-Key drip emitters per tree placed at 50 cm from the tree and connected to the main line through pipes 50 cm long.

Two irrigation strategies were used:

- (i) Full irrigated. Irrigation requirements were based on pan evaporation measurements.
- (ii) RDI. Irrigation was not supplied during the early part of the growing season. Irrigation commenced on 28 January 1990 (112 dsb), at the same timing and frequency as the FI treatment, and continued until 26 February, 1990 (141 dsb).

All treatments received natural rainfall except for those with plastic covers.

Table 2.3 Weather and irrigation on Royal Gala trees.

Date	Time (days) from bloom	Maximum temperature °C	Amount of rainfall ¹ (mm)	Pan evaporation ^{1,2} (mm)	Irrigation (litres)	
					Full	RDI
30.10.89	22	17.2	17.4	21.9	350.00	
6.11.89	29	16.9	4.0	15.6	491.52	
13.11.89	36	19.4	2.0	27.1	769.4	
20.11.89	43	19.9	5.2	29.4	917.72	
27.11.89	50	19.0	5.2	38.0	147.2	
4.12.89	57	21.1	1.5	33.1	154.0	
11.12.89	64	17.3	14.3	27.7	140.8	
18.12.89	71	19.0	4.5	36.8	127.6	
25.12.89	78	20.1	7.3	41.6	126.0	
1.1.90	85	19.7	5.1	23.4	126.0	
8.1.90	92	19.8	24.2	37.9	126.0	
15.1.90	99	20.2	0	36.0	126.0	
22.1.90	106	22.3	17.0	40.4	140.0	
29.1.90	113	23.2	7.8	40.0	116.7	231.0
5.2.90	120	26.4	35.4	40.9	116.7	116.7
12.2.90	127	25.5	2.6	37.0	116.7	116.7
21.2.90	136	23.8	4.1	37.9	116.7	116.7
28.2.90	141	25.6	3.2	37.8	116.7	116.7

¹ mean of seven preceding days

² ground level class A evaporation

Because the trees were spaced at 2 x 4.5 m, thus for comparative purposes taking the whole area, a conversion between litres and mm would imply that 1 litre = 0.1 mm. This conversion would represent an underestimate because the tree would not fully exploit the whole area.

2.7 ORCHARD MANAGEMENT

No fertilizer was applied in 1989 on these trees. Also, no foliar fertilizer sprays were applied.

The following pesticides were applied:

Days since bloom	Product	Reason
12	Metirum nitrothal isopropyl (Pallinal*) myclobutanil (Systane)	control of black spot and powdery mildew
18	Carbaryl Metiram (Polyram) Ca(NO ₃) ₂	thinning spray control of leaf roller, codling moth, leaf hopper, apple midge black spot protectant calcium spray
30	Azinphos-methyl (Gusathion) Polyram Ca(NO ₃) ₂	control of leaf roller, codling moth fungicide protectant calcium spray
50	Gusathion Ca(NO ₃) ₂ Captan	control of leaf roller, codling moth, leaf hopper, apple midge, mealy bug, scale crawlers calcium spray protectant to control blackspot, glomerella, ripe spot and sooty blotch
62	Ca(NO ₃) ₂	calcium spray, apple leaf curing midge
84	Azinphos methyl Ca(NO ₃) ₂ Captan	control of leaf roller, codling moth, leaf hopper apple midge calcium spray control of blackspot, glomerella, ripe spot and sooty blotch
101	Dodine Ca(NO ₃) ₂ Azinphos methyl	control of blackspot calcium spray control of leaf roller, codling moth, leaf hopper, apple midge
118	Dodine Carbaryl	control of blackspot control of leaf roller, codling moth, leaf hopper, apple midge
119	Dodine Carbaryl	control of blackspot control of leaf roller, codling moth, leaf hopper, apple midge

*Pallinal^R is a registered trade mark of BASF

2.8 YIELD

At maturity, fruit with the yellow ground colour were selected and harvested first. Subsequently, two other harvests were made, making the total number of harvests three. The first harvest was done on 28 February 1990, the second harvest on 8 March 1990 and the third harvest 30 March 1990. Sixty percent (60%) of fruit was harvested during the first harvest, 30% of fruit harvested during second harvest and ten percent (10%) of fruit harvested during third harvest.

Fruit from each tree was kept separate and run over a commercial fruit grader to obtain size distribution. This size was converted to weight. Thus the total yield per tree and total yield per treatment were calculated. Table 2.4 shows conversion of size to weight.

Table 2.4 Fruit sizes and their conversion to weight sizes range from smallest to largest.

Count	Average weight (g)
198-175	93-106
163	113
150	123
138	134
125	148
113	164
100-64	185

2.9 POST-HARVEST

Measurements to detect any deterioration of fruit quality with time were carried out. These included starch index, penetrometer reading, refractometer readings (Brix), colour changes, fruit minerals and the amount of disease or pest development per treatment. Thirty fruit were taken from each tree in each treatment for use in postharvest studies. These were packed in cardboard cartons.

Fruit quality attributes were measured on 10 fruit at harvest, and again after 6 weeks and 12 weeks in storage at $2^{\circ} \pm 1^{\circ}\text{C}$. After removal from storage fruit were left at 20°C to equilibrate. The same ten fruit were used for measuring each quality attribute.

2.9.1 Starch Index

Starch, the storage polysaccharide of higher plants, consists of two components, amylose and amylopectin, which are units linked in a linear fashion by α -1-4 linkages. It has a non-reducing end and a reducing end. It's molecular weight can vary from a few hundred to a few thousand. Amylose gives a characteristic blue colour with iodine, due to the ability of the halide to occupy a position in the interior of the helical coil of glucose units that is formed when amylose is suspended in water.

The degree of conversion of starch to sugar was measured using a score, after cutting fruit in half and dipping the exposed part into iodine solution, which was made up by 10 g of potassium iodate, 2.5 g iodine and 1 l hot water.

Figure 2.3 shows the scores used. The starch pattern used was that recommended for Granny Smith. The more blue colour represents more starch and less blue represents less starch (see Appendix 1).

Figure 2.3 Starch pattern indices used for obtaining starch scores on Granny Smith apples.

STARCH-IODINE SCORES FOR GRANNY SMITH APPLES

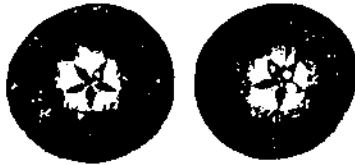
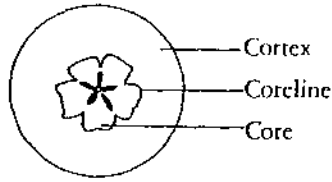

SCORE 0.
All cortex and three-quarters of
core blue



SCORE 1.
Half area within core line white,
cortex blue



SCORE 2.
All area within core line white,
cortex blue



SCORE 3.
All area within core line white,
quarter of cortex area white,
remainder blue, usually cortex
is patchy white.



SCORE 4.
All area within core line white,
one-half of cortex white,
remainder blue, usually cortex
is patchy white



SCORE 5.
All area within core line white,
three-quarters of cortex area
white, one-quarter patchy blue.



SCORE 6
All surface white.

2.9.2 Penetrometer

Measurements of firmness are used in the produce industry as indicators of the maturity of fruits. To do this, an instrument is used that determines the consistency of a material by measurement of the depth to which a standard probe can be penetrated into it. In this case the instrument used was an Effegi (1-20 kg), with a probe diameter of 11 cm. Penetrometer recordings were made on pared surface of each side of fruit at the equator.

2.9.3 Refractometer

A refractometer measures the index of refraction of juice from fruit and it is an indicator of soluble solids and sugar concentration. An Atago (0-20% Brix) refractometer was used to measure the index of refraction of the juice squeezed from an apple slice taken from across the equator of each fruit.

2.9.4 Colour

Being the quality factor that consumers notice first, colour is extremely important to quantify. The measurement by instrumental means is limited only by the ingenuity of the operator (Francis, 1980). Many instruments have been developed to measure fruit colour.

However, in this particular case, the instrument used was the Minolta Chromameter CR 100. The instrument locates a point in 3-dimensional space. It measures the reflection and transmission from the point.

2.9.5 Minerals

From the equator a core of each fruit a sample was taken. Using a standard core borer of 1 cm diameter, twenty samples were taken from each treatment. These were then analysed for mineral content, i.e. nitrogen, potassium, calcium, magnesium and phosphorus.

Potassium, calcium and magnesium were determined by atomic emission and absorption spectroscopy following digestion in Nitric acid. Total phosphorus and nitrogen were determined following Kjeldahl digestion by calorimetric autoanalysis methods (Twine and Williams, 1971).

2.9.6 Data Analysis

Data was analysed using a Prime and Network computer system at Massey University. Software used were SAS, Quattro, Grapha and Xywrite III. For data obtained in the orchard had its statistical analysis done using a multivariate analysis of variance. Due to the limitations imposed by two main blocks the experimental design was restricted to two degrees of freedom for the main effects (irrigation) and four degrees of freedom for interactions (irrigation x cover).

CHAPTER 3

SOIL MOISTURE RESPONSES

3.1 INTRODUCTION

The water content of a soil is usually defined as the amount of water lost when it is dried at 105°C, expressed either as the weight of soil, or as the volume of water per unit volume of soil. The volume of water per unit volume of soil indicates the amount of water available to plant roots more clearly than the weight per unit weight of soil. However, content on a percentage basis, either gravimetric or volumetric, tells little about the amount of water available to plants. Sand may be saturated at a water content that would be too dry for plant growth in a clay soil. Furthermore, following integration with depth the water content can be expressed as centimetres of water per unit of soil depth.

When water is applied to the soil surface, it infiltrates and drains downward through the larger pores by gravitational flow. However, some is retained by capillary forces in the smaller pores of diameter less than about 30-60 μm , and by adsorption on the surface of soil particles. These constitute the matrix forces. They hold that part of the soil water available to plant. A variable fraction of the water in the soil's matrix is held so firmly and moves so slowly that it is treated as unavailable to plant (Kramer, 1983).

If a homogeneous profile is examined at any moment during infiltration under ponding, one finds that the surface is saturated, perhaps to a depth of several millimetres. Beneath this zone of complete saturation is a less than saturated and lengthening zone of apparently uniform wetness known as the transmission zone. Beyond this zone there is a wetting zone, in which soil wetness decreases with depth at a steepening gradient to a wetting front, where the moisture gradient is so steep that there appears to be a sharp boundary

between the moistened soil above and the relatively dry soil beneath (Hillel, 1980).

Miller and Gardner (1962), conducted experiments on the effects of thin layers of different texture sandwiched into uniform profiles. They showed that although in any conducting soil the matrix suction and hydraulic head must be continuous throughout the profile regardless of layering sequence, the wetness and conductivity may exhibit abrupt discontinuities at the interlayer boundaries. The steady state downflow of water through a two-layer profile had earlier been analysed by Takagi (1960), who showed that where the upper layer is less permeable than the lower layer, more negative pressure develops in the lower layer and these can remain constant throughout a considerable depth range. This tends to limit drainage in the unsaturated state.

Sandy soils contain less water at saturation and drain much more rapidly at first than clay soil. They may lose half as much water as the loam, and nearly five times as much water as the clay during the first two days. Thereafter the difference decreases and is eventually reversed, as further drainage from the sand slows down to a very low rate while drainage from the loam and clay persists at appreciable rates for many more days.

When the initial wetting depth is small and the underlying soil is relatively dry the suction gradients augmenting the gravitational gradient are likely to be strong and hence induce a rapid rate of redistribution.

Available water will be removed from the soil profile under apple trees by mechanisms other than drainage and redistribution. Evaporation from the soil surface will

also occur, the extent depending on the nature of the surface cover. However the major loss will be by evapotranspiration from the canopy surface. Water will be removed from the zone of the soil where the root density is highest regardless of whether roots belong to the trees or to some cover crop. Many studies have examined the relationship between root growth, soil moisture content and irrigation in orchards (Goode et al. 1978 a, b; Levin et al. 1980).

The objective of this study was to evaluate the effectiveness of different methods for manipulating the soil moisture content under mature Royal Gala apple trees which either received full irrigation throughout the season or were exposed to no irrigation for the first part of the season followed by full irrigation (RDI - regulated deficit irrigation).

3.2 RESULTS

3.2.1 Soil moisture content and profile storage

The volumetric soil moisture content (θ) measured over the 0-900 mm soil profile was 225 mm at the time of the initial neutron probe measurements (22 dsb). This θ was integrated with respect to depth to provide the profile water storage W . This W decreased steadily with no differences between cover treatments until 43 dsb, when irrigation commenced for the fully irrigated (FI) treatments (Fig. 3.1).

Immediately after irrigation was applied, W increased and continued to do so until 87 dsb after which it remained constant for the remainder of the season (Fig. 3.2). Although not

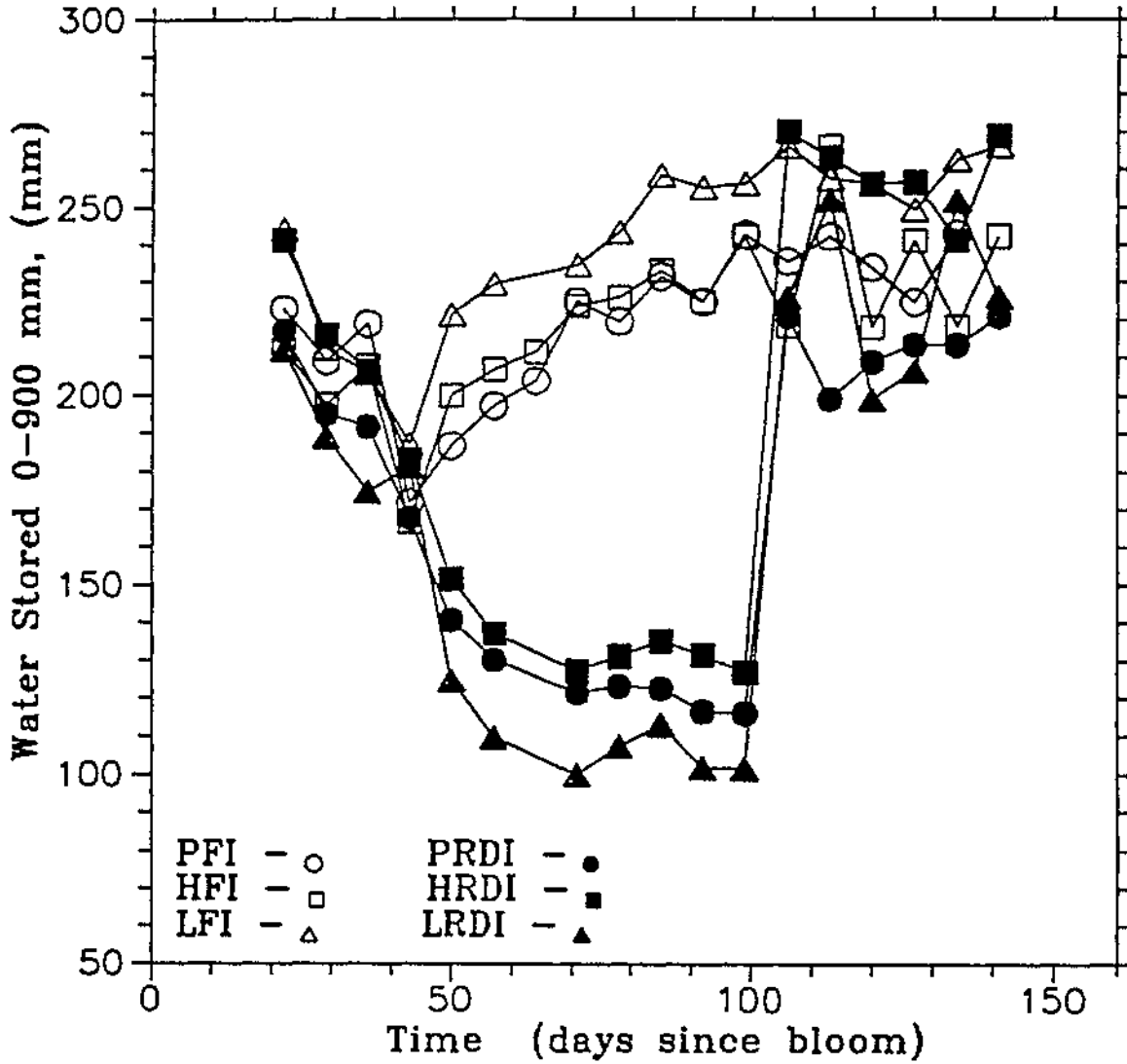

Figure 3.1

Total water storage W during the 1989/90 growing season in the top 900 mm of soil under Royal Gala apple trees which have received full irrigation (FI) or regulated deficit irrigation (RDI) with or without different types of ground cover (Black-polyethylene=P; Herbicide strip=H; Lucerne cover=L).

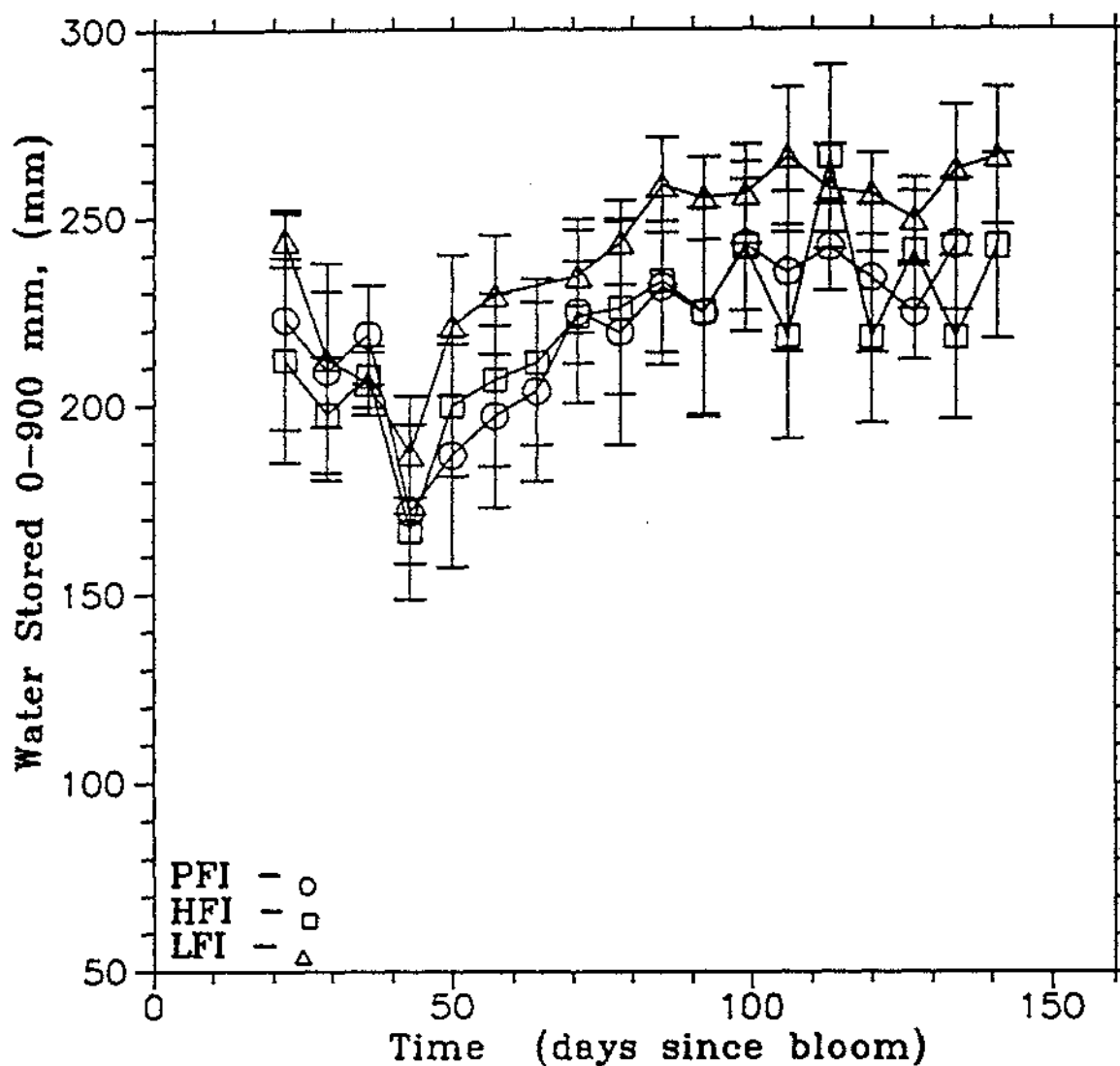

Figure 3.2 Total water stored W during the 1989/90 growing season under Royal Gala apple trees receiving full irrigation throughout the season with or without different types of ground cover. (Black polyethylene cover=P; Herbicide strip=H; Lucerne cover crop=L.) The bars equal \pm S.E.M.

significantly different, the lucerne FI treatment constantly contained more stored water than the HFI and PFI treatments. Even when trees were in full leaf and carrying a full crop the equilibrium amount of water stored in these soils when fully irrigated, was approximately 250 mm.

Water content of soils in the RDI treatment decreased in a linear fashion from 22 dsb to 58 dsb (Fig. 3.3) after which little change in W occurred until 100 dsb. There was no difference between HRDI and PRDI treatments which had W values of approximately 130 mm. In LRDI W was consistently, but not significantly lower than the other two treatments with a value of about 105 mm. The mean value of W for the three RDI treatments between 58 dsb and 100 dss was 122 mm, which was 49% of the average W in the FI treatments which had reached an equilibrium.

Irrigation of the RDI plots commenced 100 dsb. There was an immediate increase in W , which returned to approximately the same values as measured for the FI treatments. Upon rewetting it seemed that, in general for the remainder of the season, the W 's in the PRDI and LRDI treatments were lower than in HRDI treatments. This suggests that for those treatments perhaps inadequate irrigation was being supplied to enable the soil profile to be fully replenished.

3.2.2 Water content at different depths

The capacity of the soil to hold water varied with depth. θ was highest in the 0-300

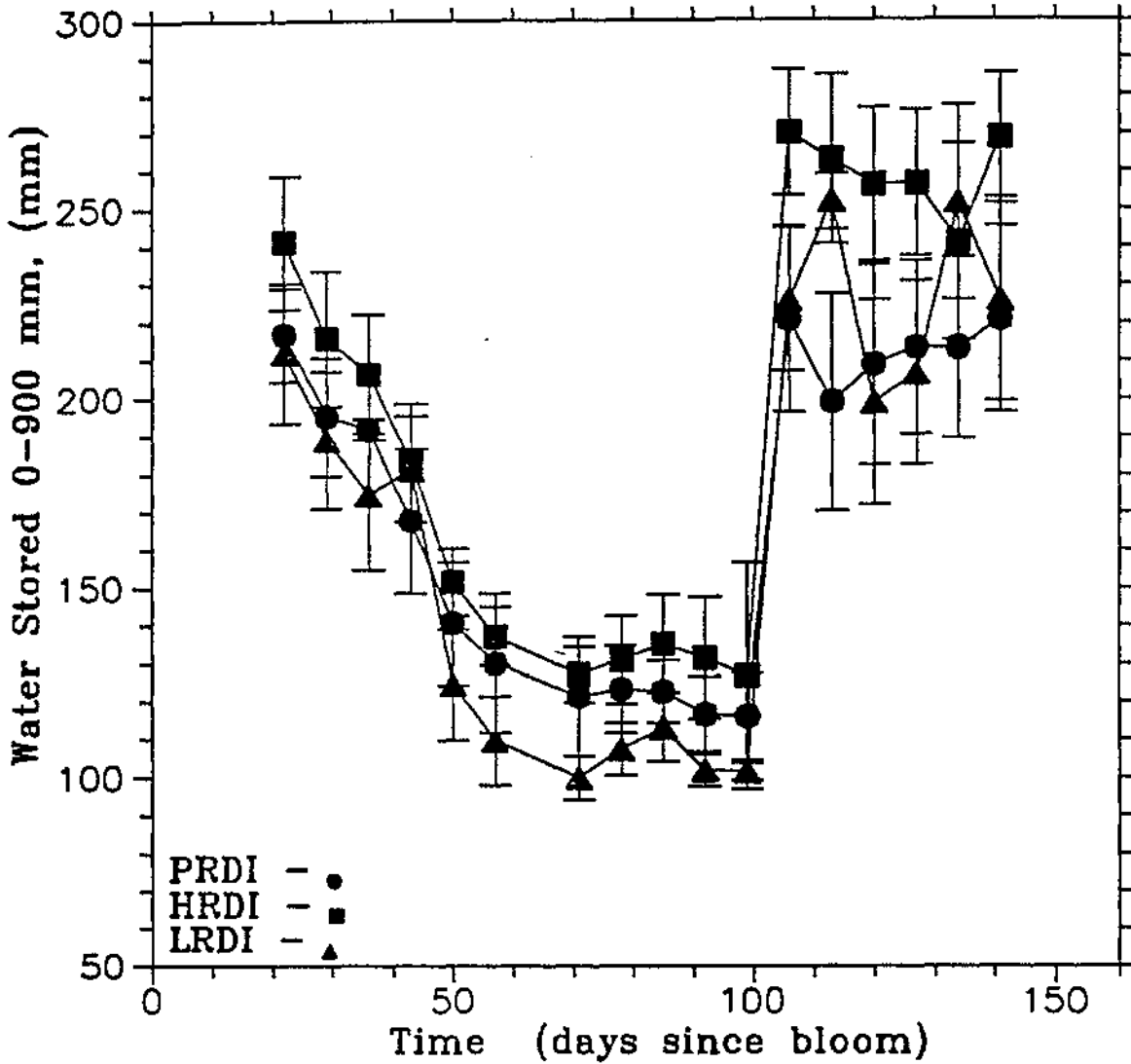

Figure 3.3 Total water stored W during the 1989/90 growing season under Royal Gala apple trees receiving RDI treatments (no irrigation until 100 dsb) followed by full irrigation with or without different types of ground cover (Black polyethylene covers=P; Herbicide strip=H; Lucerne cover crop=L) Bars equal \pm S.E.M.

mm zone, ranging between 0.30 and 0.36 $\text{m}^3 \text{m}^{-3}$ over all treatments at the commencement of neutron probe measurements (Fig 3.4). In the FI treatments, using herbicide treatment as an example, before any irrigation was applied (22 dsb) θ for the different zones was 0.30, 0.20, 0.095 and 0.09 $\text{m}^3 \text{m}^{-3}$ over the depths of 0- 300 mm, 300-500 mm, 500-700 mm and 700-900 mm respectively.

After irrigation was started, θ increased at all depths, so that by 50 dsb it had reached 0.32, 0.26, 0.17, and 0.045 $\text{m}^3 \text{m}^{-3}$ for 700-900 mm depths respectively (Fig 3.4).

This recharging of θ did not occur equally, or at the same time interval for each depth. For example in the 0-300 mm zone, the largest increase in θ occurred between 29 and 36 dsb, while in the 700-900 mm zone the largest increase occurred between 43 and 50 dsb.

In the HRDI treatment, θ decreased with time between 22 dsb and 50 dsb. A total of 0.11 $\text{m}^3 \text{m}^{-3}$ was withdrawn from each of the 0-300 and 300-500 mm zones and 0.09 $\text{m}^3 \text{m}^{-3}$ from each of the 500-700 and 700-900 mm zones over the time of the first five measurements (22 to 50 dsb). Weekly changes in θ were not uniform. The greatest change was between 43 and 50 dsb in the two top zones of the soil; below 500 mm the largest amount of water extracted seemed to be between 22 and 29 dsb.

When irrigation started in the RDI treatment (100 dsb), there was an immediate increase in θ at all depths (Fig 3.5). The increase in θ for the total soil profile was 0.60 $\text{m}^3 \text{m}^{-3}$ but this did not occur evenly at each depth. The increase in θ was 0.13, 0.17, 0.16 and 0.15 $\text{m}^3 \text{m}^{-3}$ for the 0-300, 300-500, 500-700 and 700-900 mm zones respectively. After

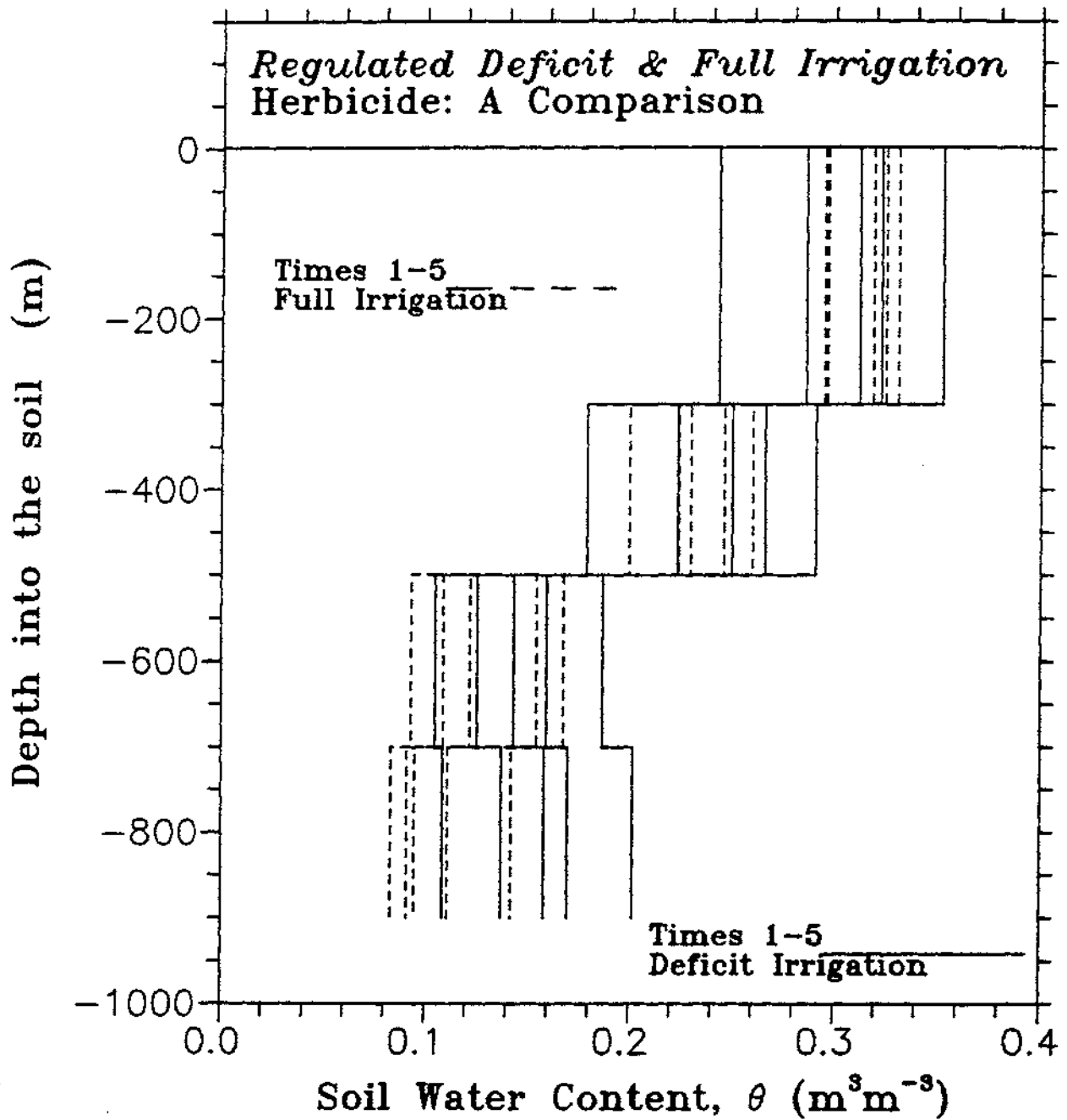

Figure 3.4 Soil water content θ at different depths under Royal Gala apple trees exposed to fully irrigated (---) or RDI (—) treatments. Vertical lines indicate sequential times of neutron probe measurements.

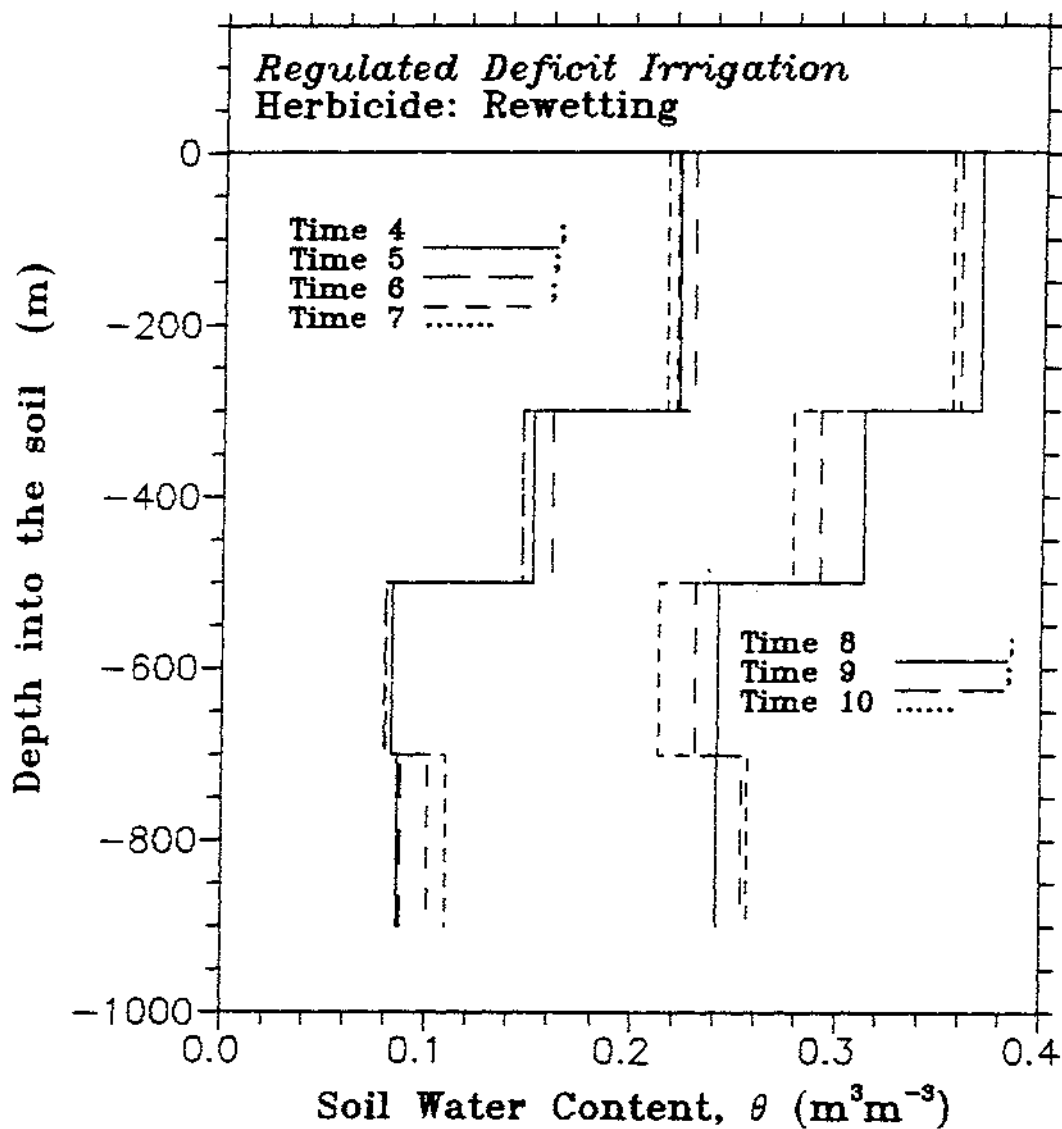

Figure 3.5 Soil water content θ at different depths under Royal Gala apple trees exposed to RDI treatment prior to (Time 4 to 7; left hand series of vertical lines) and after resumption (Time 8-10; right hand series of vertical lines) of irrigation.

Time 4= 71 dsb on 18 Dec 1989

Time 5= 78 dsb on 25 Dec 1989

Time 6= 85 dsb on 1 Jan 1990

Time 7= 92 dsb on 8 Jan 1990

Time 8= 99 dsb on 15 Jan 1990

Time 9=106 dsb on 22 Jan 1990

Time 10=113 dsb on 29 Jan 1990

rewetting θ decreased at subsequent times of soil moisture measurement except at 700-900 mm where θ increased slightly, indicating that overall water was being used faster than it was being replaced by irrigation.

3.3 DISCUSSION

The increase in the basic understanding of infiltration, redistribution, retention and uptake of water by plant roots has revolutionised the concept of field capacity and available water which had become so ingrained in irrigation practice. The application of new concepts for irrigation management, such as RDI, have enabled soil water content to be manipulated to suit the needs of plants at any particular physiological stage.

The soil management techniques studied here, effectively enhanced the soil water deficit in this environment. The lucerne treatment reduced the soil water content to a greater extent than that obtained using plastic covers, or the herbicide control as the control received rainfall and plastic did not. The higher soil water content in the control treatment (Herbicide RDI) can be explained by the advantage of receiving this bonus of rainfall. Bacon (1974) has reported that black plastic mulching on apple trees prevented evaporation and retained soil moisture. This probably occurred in the present experiment.

Although distribution of roots of the apple tree and lucerne were not determined in this experiment, it is logical to expect that water uptake will be influenced to some extent on the location and density of roots in the soil profile.

Goode and Hyrycz (1970) found that irrigation increased the weight of blackcurrant roots at several distances from the bush. There was no effect of irrigation on distribution but soil moisture deficit was related to density. Goode et al. (1978a) showed that irrigation

increased root density in apple trees ('Cox'/MM104) although the effect was significant only at 0-15 cm depth. In contrast there was no significant effect of irrigation on the total amount of fine root (less than 1 mm diameter) on trees (-) of 'Laxton's Superb'/M2, although the treatment affected root distribution both at 1m and 2m from the tree (Goode and Hyrycz, 1964). Irrigation increased root weight at 0 to 15 cm and reduced it at 15 to 30 cm depth. Yakushev (1972) and Ponder and Kenworthy (1976) also increased root production by irrigation. Doichev (1977), however, found no effect of irrigation on root distribution, nor did Sidorenko (1973). Thus the effects of irrigation are variable, probably as a result of variations in other factors which influence root growth e.g. tree growth, soil conditions.

The method of irrigation can also influence root distribution. Huguet (1973) found that flood irrigation which was wasteful of water, limited rooting to a superficial zone, while localised irrigation with one application point at the tree trunk, resulted in poor root growth because of waterlogging and excessive leaching. Doichev (1977) compared furrow and sprinkler irrigation with apple trees of 'Golden Delicious'/M7. With both methods most roots were at 0 to 60 cm depth equally distributed, however the main horizontal roots were deeper and growth was enhanced more with furrow irrigation than with overhead sprinkler irrigation. Taylor (1974) investigated the effect of trickle (drip) irrigation on mature peach trees, and found fine roots in the wetted zones, but only where the drainage was good. Roots were concentrated within a 30 to 40 cm radius, but with more under the dripper. In contrast, Goode et al. (1978b) observed 4 to 5 times more fine roots, both in the vicinity of 30 cm radius and beneath the nozzle of a drip irrigation system. In the absence of irrigation, most roots were present at 0-30 cm depth but with irrigation they were at 0 to 60 cm depth. The effects of trickle irrigation on apple root growth in Israel have been reviewed by Levin et al.

(1980). Root distribution depended upon the volume of wetted soil, which was related to the soil's hydraulic conductivity and the rate and duration of water application. The wetted soil volume was usually 30 to 50% of the whole soil volume. The root system adapted to this by becoming restricted to within 60 cm of the nozzles. Under sprinkler irrigation 80% of the apple root system occurred at 0 to 60 cm depth (Levin et al. 1980). They attributed this to excessive water at depth. Root distribution at 60 to 120 cm depth was greater when a relatively low moisture threshold was maintained in this zone during the main period of root growth.

The above reports indicate that there is a relationship between root growth and irrigation method. Root density and distribution in the soil profile is very much affected by water availability, and also by the degree of aeration in the soil. In the present study the soil drying pattern showed that water uptake was mainly from the top 500 mm of soil when the soil was wet but shifted towards the lower layers as soil dried out. This is in agreement with reports by Garnier et al. (1986) for lucerne, who demonstrated that lucerne extracted water from deep soil only after water from shallow layers had been utilized.

The present work indicates that a lucerne cover crop in the orchard was able to remove water from the entire soil profile, but there is some indication that it takes water from the top layers first before extracting it from deeper in the soil.

In the RDI treatments soil moisture content decreased steadily until 83 dsb, after which it did not decrease further, but remained at a constant level at about 49% of the total amount of water held in the FI treatments. While the LRDI treatment achieved the lowest

θ , the pattern was the same for both PRDI and HRDI treatments. It is likely that water from outside the zones measured, somehow moved into the 0-900 mm profile to maintain this constant base level in the non-irrigated plots. This may have resulted from either (or both) vertical and lateral capillary movement of water (Kramer, 1963) into the drying zone.

It can be concluded that a deep-rooted cover crop such as lucerne has the capacity to extract water down to 900 mm in the area surrounding mature apple trees. Such a treatment seemed to be more effective than plastic covers and herbicide control treatment. Whether the combined effect of lucerne and RDI in reducing θ is enough to induce sufficient stress in apple trees, to reduce vegetative growth without affecting fruit growth and quality, will be examined in the following chapter.

CHAPTER 4

APPLE TREE RESPONSE TO WATER STRESS

4.1 INTRODUCTION

Low soil moisture which results in reduced ψ_1 affects vegetative and fruit growth differently (Chalmers, 1989), provided that water stress occurs during the early part of fruit growth. This indicates that the processes involved in shoot elongation are more sensitive to internal ψ_1 than are those involved in fruit growth. During the reproductive cycle, the physiology of many plants is dominated by internal processes and conditions associated with the development of fruits (Chalmers, 1989). How much vegetative growth is affected by water stress depends upon the intensity of the stress and the time at which it occurs (Assaf et al., 1974).

Trunk growth is reduced by water stress (Goode and Ingram, 1971). Mitchell et al. (1984) showed that trunk growth of pears was slowed by RDI and that overall vegetative growth (as measured by weight of prunings) was also reduced.

The main objective in fruit production is to obtain the best quality fruit with the lowest possible inputs. Such inputs include irrigation. Any reduction in the amount of water applied by irrigation should only happen when the induced water stress is most likely to have some beneficial effect on productivity and eventual fruit quality. Research in fruit quality is highly market-driven, with bigger and better quality fruit being the ideal. If water stress can affect quality attributes positively, and at the same time save on irrigation costs, then it is extremely beneficial to both the grower and the consumer.

The performance of RDI in dry environments, such as Australia, has proved to be

an excellent technique to control tree vigour while increasing yield of peach trees (Chalmers et al., 1981). RDI could be adopted in humid climates provided that soil water content could be controlled in the early part of the growing season following the normal wet winters which result in high soil water content. The stage at which water stress should be applied to avoid harmful effects on fruit growth should be clearly defined for each type of fruit (Chalmers, 1989).

The objective of this experiment was to investigate the influence of varying soil moisture content on leaf water potential (ψ_l), on vegetative and fruit growth and fruit quality of Royal Gala apples during the development of stress and after its relief later in the season.

4.2 RESULTS

4.2.1 Leaf Water Potential (ψ_l)

Leaf water potential (ψ_l) was measured at midday and dawn on three trees on each treatment commencing on 30.10.89 which was 22 dsb.

All full irrigation treatments had higher pre-dawn and midday ψ_l than did RDI treatments. During the period of water stress induction, leaves from trees with LFI treatment had an initial pre-dawn ψ_l of -0.6 MPa; this fluctuated over the first 65 days before increasing to -0.4 MPa where it remained for 30 days and where it remained at a more or less constant value throughout the remainder of the experiment (Fig. 4.1). The corresponding pre-dawn ψ_l

Figure 4.1 Leaf water potential ψ for Royal Gala apple leaves taken from HFI, HRDI, PFI, PRDI, LFI and LRDI.

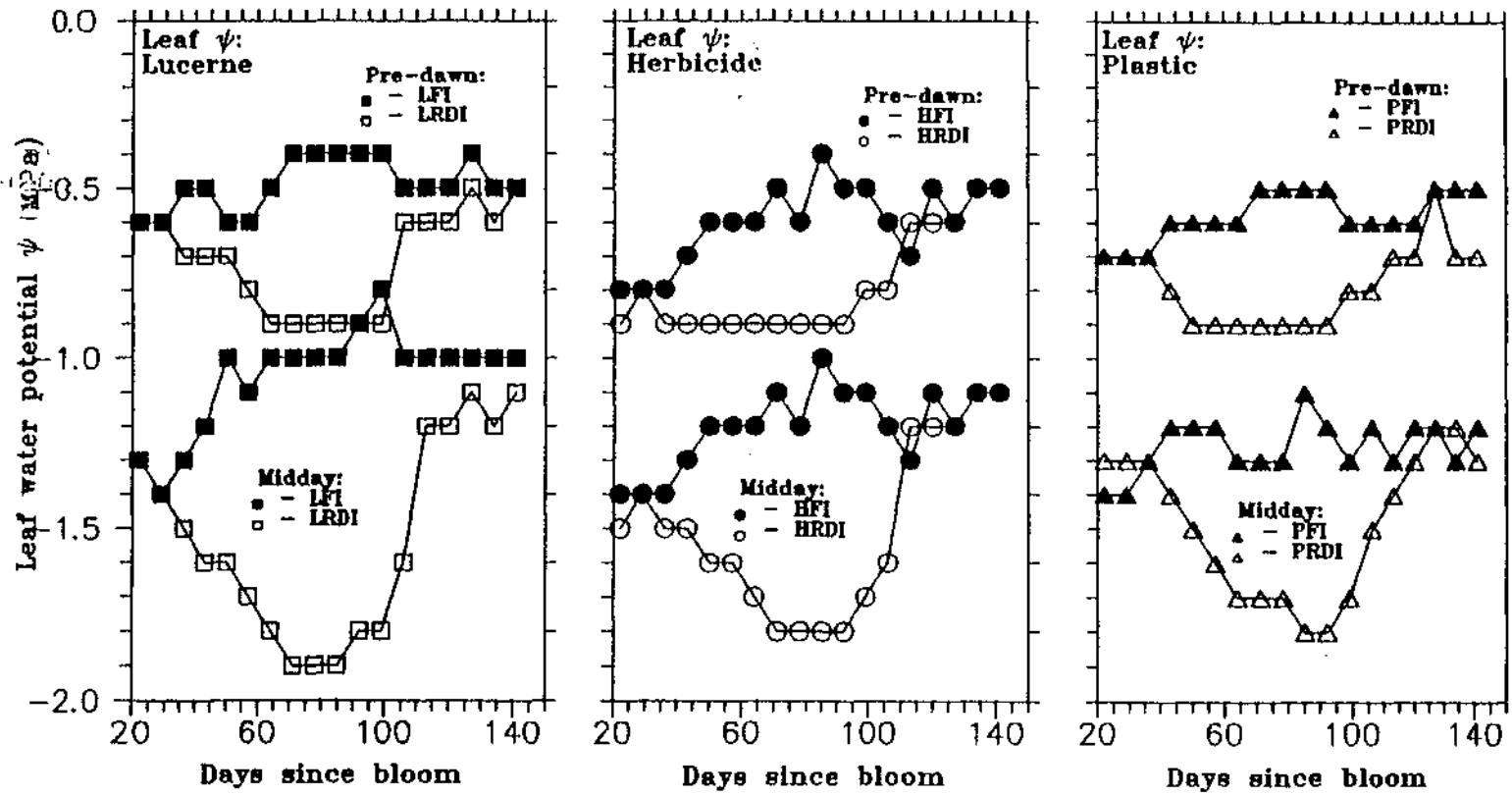

value of leaves from the LRDI treatment started at the same value of -0.6 MPa but gradually decreased to a minimum value of -0.9 MPa after 65 days. This value was maintained for the following 30 days. After irrigation started there was a sharp increase in leaf water potential to -0.6 MPa where it remained for the remainder of the experiment.

Leaves in the HFI treatment started with a pre-dawn ψ_1 value of -0.8 MPa at 20 dsb and gradually increased to a minimum of -0.4 MPa at 90 dsb and then remained almost constant for the remainder of the season. Leaves from the HRDI treatment had a pre-dawn ψ_1 value of -0.9 MPa at the beginning of the experiment. This remained constant at -0.9 MPa for 90 dsb and after full irrigation had been imposed, increased over the next 20 days to be equal to the -0.4 MPa attained by leaves from the HFI treatment.

Leaves from the PFI treatment maintained a pre-dawn ψ_1 of -0.7 MPa for 35 dsb before increasing stepwise to a maximum value of -0.5 MPa and then -0.6 MPa for the rest of the season. Leaves from the PFI treatment, measured at midday, started at -0.7 MPa and remained at this ψ_1 for 35 dsb after which it decreased to -0.9 MPa at 50 dsb and remained at this level for the next 60 days. Once irrigation commenced ψ_1 increased steadily to a relatively constant value of -0.7 MPa, which was 0.1 to 0.2 MPa lower than the ψ_1 of the PFI treatment.

All full irrigation treatments maintained relatively high values of pre-dawn ψ_1 (between -0.4 to -0.6 MPa) once they had increased over the first 60-82 dsb. This reflected a general lack of pre-dawn stress in the fully irrigated trees as water was continuously available. However, all leaves from trees in RDI treatments had a gradually decreasing pre-dawn ψ_1

during the 70-80 dsb, reflecting the increasing tree stress resulting from a decreasing soil water content due to the lack of irrigation. When full irrigation was applied on the RDI treatments, pre-dawn ψ_i increased rapidly, reflecting the removal of stress due to the availability of water to the trees. In the HRDI and PRDI treatments, ψ_i rose to be similar to corresponding full irrigation treatments; however in the LRDI treatment the new equilibrium value of ψ_i did not quite reach that of the fully irrigated trees. This may have reflected the greater degree of water stress sustained by trees in this treatment.

4.2.2 Fruit Growth

Leaf water potential is a measure of the water status of the plant and might be expected to affect fruit growth. Measurements of fruit diameter did not commence until 62 dsb, by which time fruit diameter was already 32 mm with no differences between any of the treatments (Fig. 4.2).

Fruit from fully irrigated trees all increased rapidly in diameter between 63 and 70 dsb (Fig. 4.2) after which the rate of growth continued to increase but at a slower rate. Fruit from all treatments had approximately the same final fruit diameter at harvest (135 dsb).

RDI treatments affected fruit diameter increase between the first two fruit measurements taken (63-70 dsb). Rate of fruit growth was decreased by RDI regardless of cover treatments. The herbicide (HRDI) had the least persistent effect, as the rate of fruit diameter increase was reduced briefly between 70 and 80 dsb. However by 85 dsb fruit diameter for this treatment had recovered and remained the same as the HFI treatment for the

rest of the season. Diameter of fruit from trees in the plastic RDI treatment was less than that from the PFI treatment from 70 to 100 dsb but from 110 dsb fruit diameter was the same for both treatments. Fruit from the lucerne RDI treatment was smaller than the LFI treatment from 70 dsb through to harvest; although trees from LRDI received irrigation from 113 dsb and fruit diameter increased slightly from this time until harvest, fruit remained smaller than that from fully irrigated trees.

After being put on the grader, fruit was sorted into different sizes. Final fruit sizes in both HFI and HRDI were distributed in equal percentages per size (Fig. 4.3.) Both HFI and HRDI had 21% of their fruit falling in the small size range. HFI and HRDI both had about 30% of their fruit in medium size range. In both the medium and large size, the distribution of percentage sizes were the same in both HFI and HRDI.

In both Plastic FI and PRDI the distribution of fruit percentage in each size was the same (Fig. 4.4). But in Lucerne FI and LRDI, the percentage distribution of small fruit was 20% and 52%, respectively, making the distribution different (Fig. 4.5). In the medium₁ size LFI had 30% of its fruit and LRDI had 23% of its fruit. But the bigger medium₂ fruit distribution was 40% for LFI and 25% for LRDI, and finally LFI has 10% large fruit while no large fruit were found in the LRDI treatment.

4.2.3 Trunk Diameter

Trees grown with a herbicide treatment were not influenced by irrigation treatment. However, for both lucerne and plastic cover treatments, the RDI treatments reduced trunk

diameter by 35.7% and 31.2%, respectively (Fig. 4.6). Trees grown with full irrigation and plastic covers did not increase trunk diameter as much as those under lucerne which in turn did not increase as much as those grown in the herbicide strip with full irrigation.

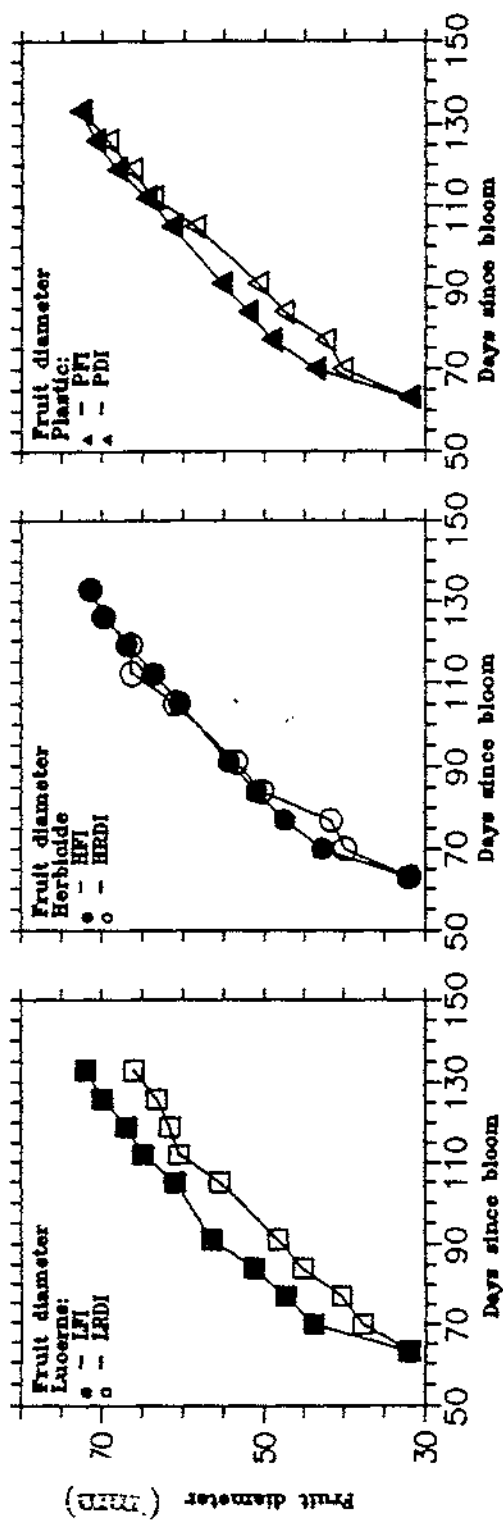

Figure 4.2 Fruit diameter (mm) in fully irrigated (FI) and regulated deficit irrigated (RDI) treatments.
L = lucerne cover crop; H = herbicide; P = plastic.

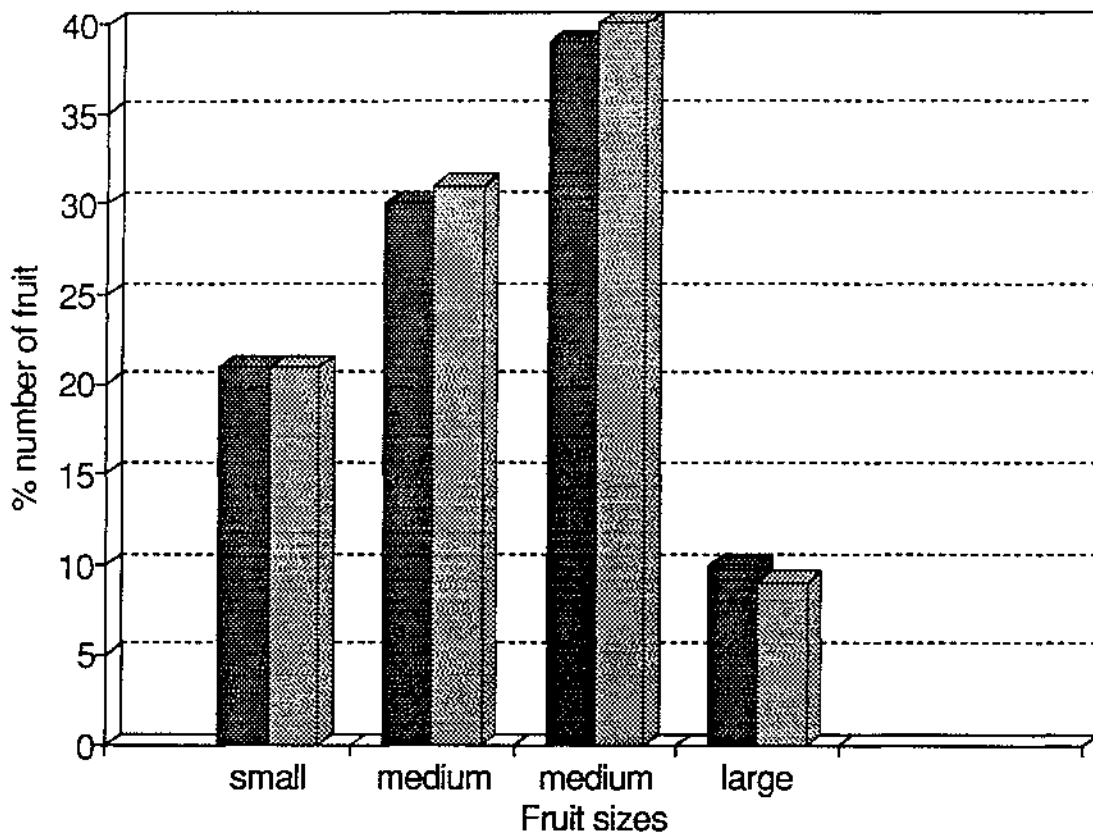

Figure 4.3 Fruit size distribution in HFI (dark hatching) and HRDI (light hatching) treatments for small (198-175), medium₁ (163-150), medium₂ (138-125) and large (113-64) Royal Gala apples.

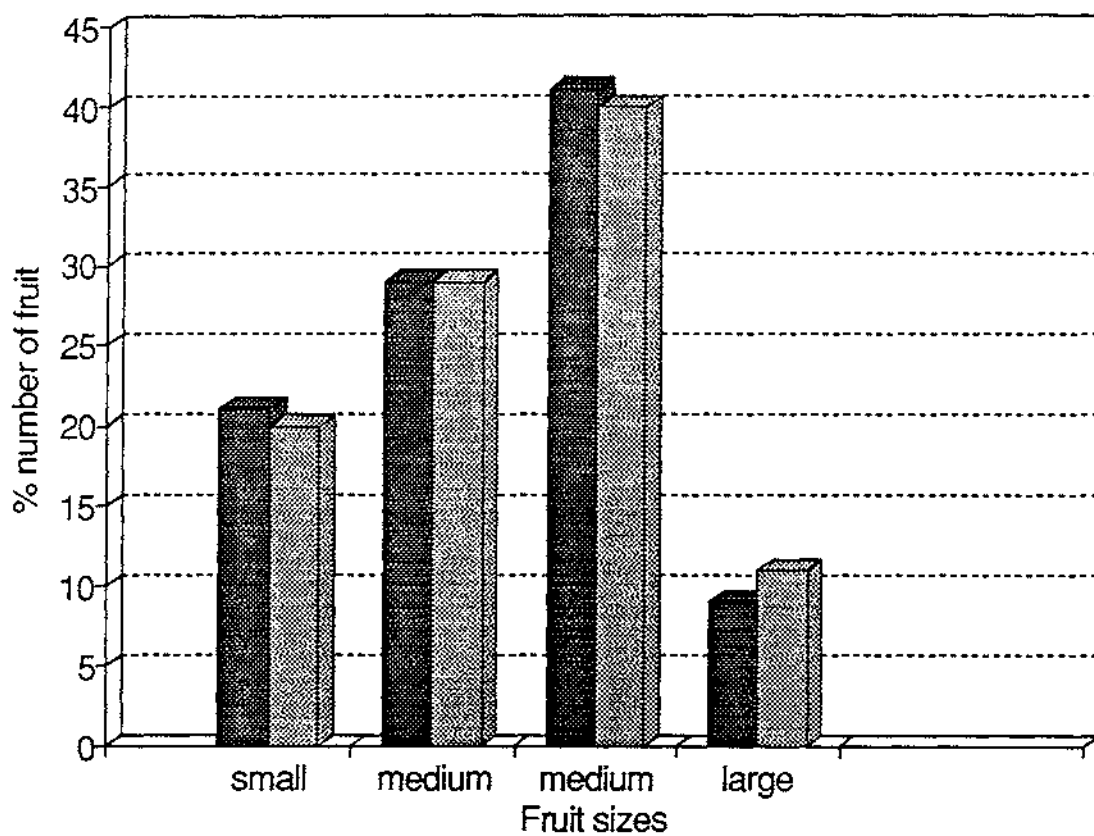

Figure 4.4 Fruit size distribution in PFI (dark hatching) and PRDI (light hatching) treatments for small (198-175), medium₁ (163-150), medium₂ (138-125) and large (113-64) Royal Gala apples.

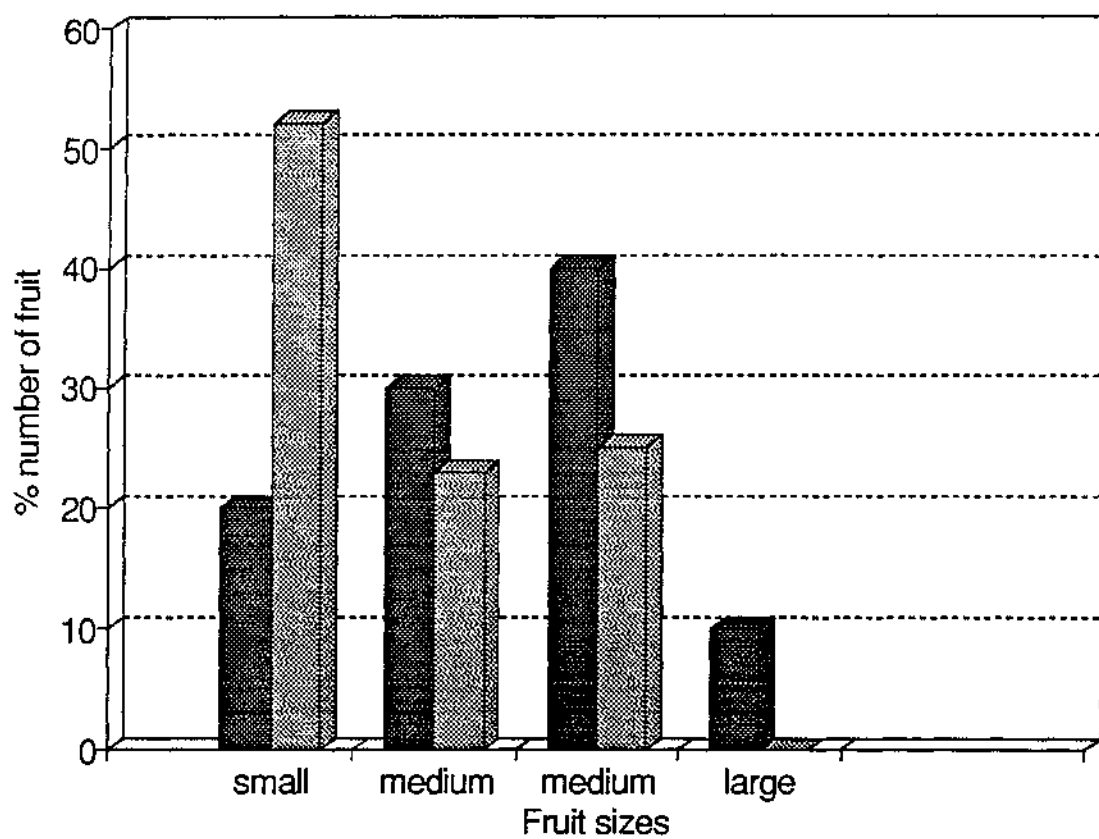

Figure 4.5 Fruit size distribution in LFI (dark hatching) and LRDI (light hatching) treatments for small (198-175), medium₁ (163-150), medium₂ (138-125) and large (113-64) Royal Gala apples.

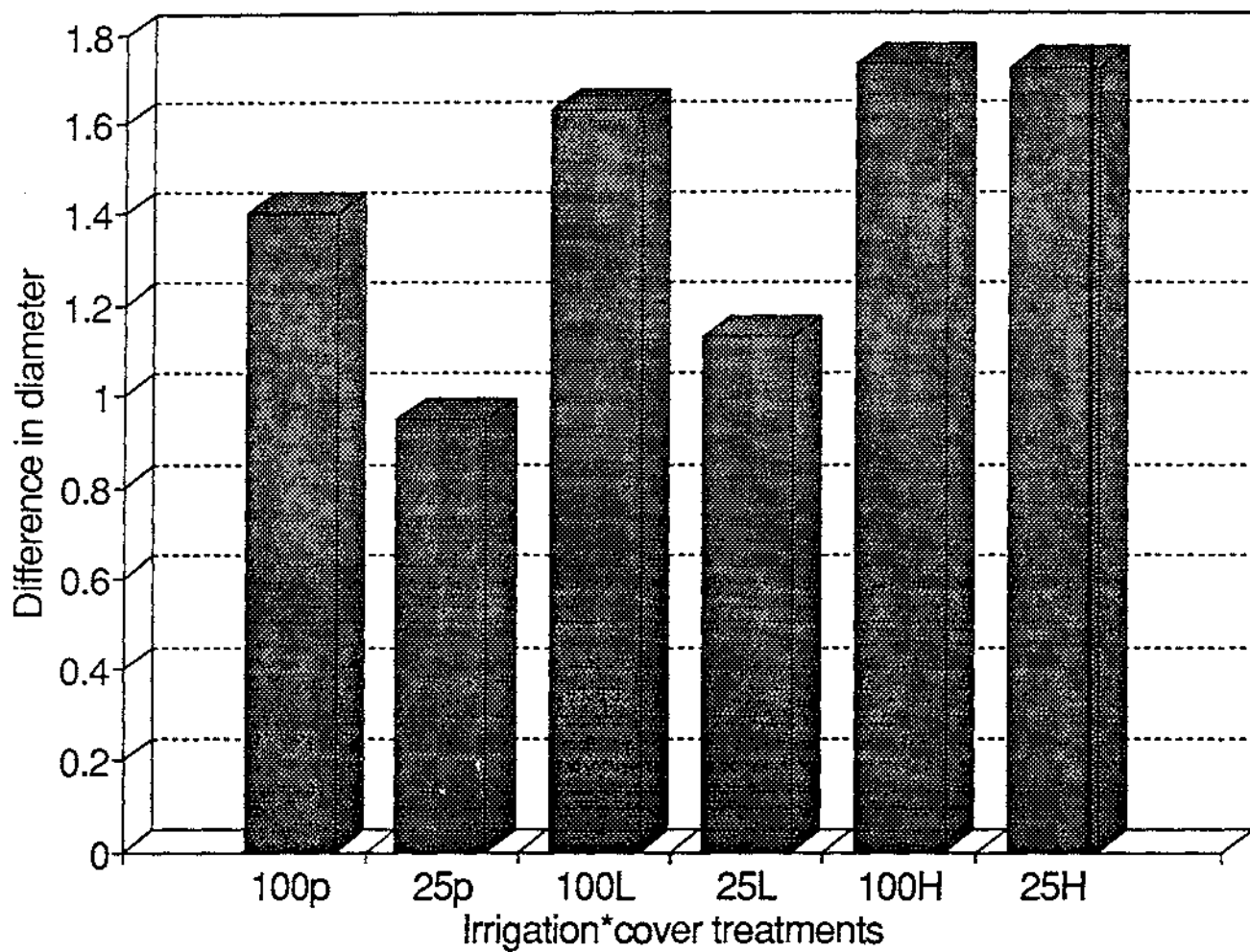

Figure 4.6 Trunk diameter difference on Royal Gala apple trees taken above the stock/scion union. Differences were calculated between records taken in July 1989 and July 1990.

P = plastic; L = lucerne; H = herbicide
 100 = full irrigation; 25 = RDI

4.2.4 Pruning Weights

Pruning weights of fully irrigated trees varied between treatments with LFI producing 38.9% more prunings than PFI; HFI trees produced an intermediate amount. RDI trees consistently produced less prunings than fully irrigated trees in all treatments. The largest decrease in pruning weights, compared with the LFI, occurred in the LRDI treatment (83.3%) followed by PRDI (72.2%) and then HRDI (55%) (Fig. 4.7).

4.2.5 Fruit Quality

Water stress can influence fruit quality (Ben Arie and Lurie, 1986). It is the potential for improvement in fruit quality, together with a saving on irrigation costs, which makes RDI an extremely beneficial management method.

4.2.5.1 Firmness

Firmness declined with time during storage regardless of harvest treatment (Table 4.1). At harvest fruit from trees exposed to RDI treatments were firmer than fruit from trees exposed to full irrigation, again regardless of treatment. After 6 and 12 weeks at 2°C fruit from Lucerne RDI treatments were firmer than fruit from all other treatments.

4.2.5.2 Soluble solids

Soluble solids content increased in all treatments during 12 weeks storage at 2°C. Soluble solids percentage was higher in the RDI treatments at harvest, and this difference was maintained in storage.

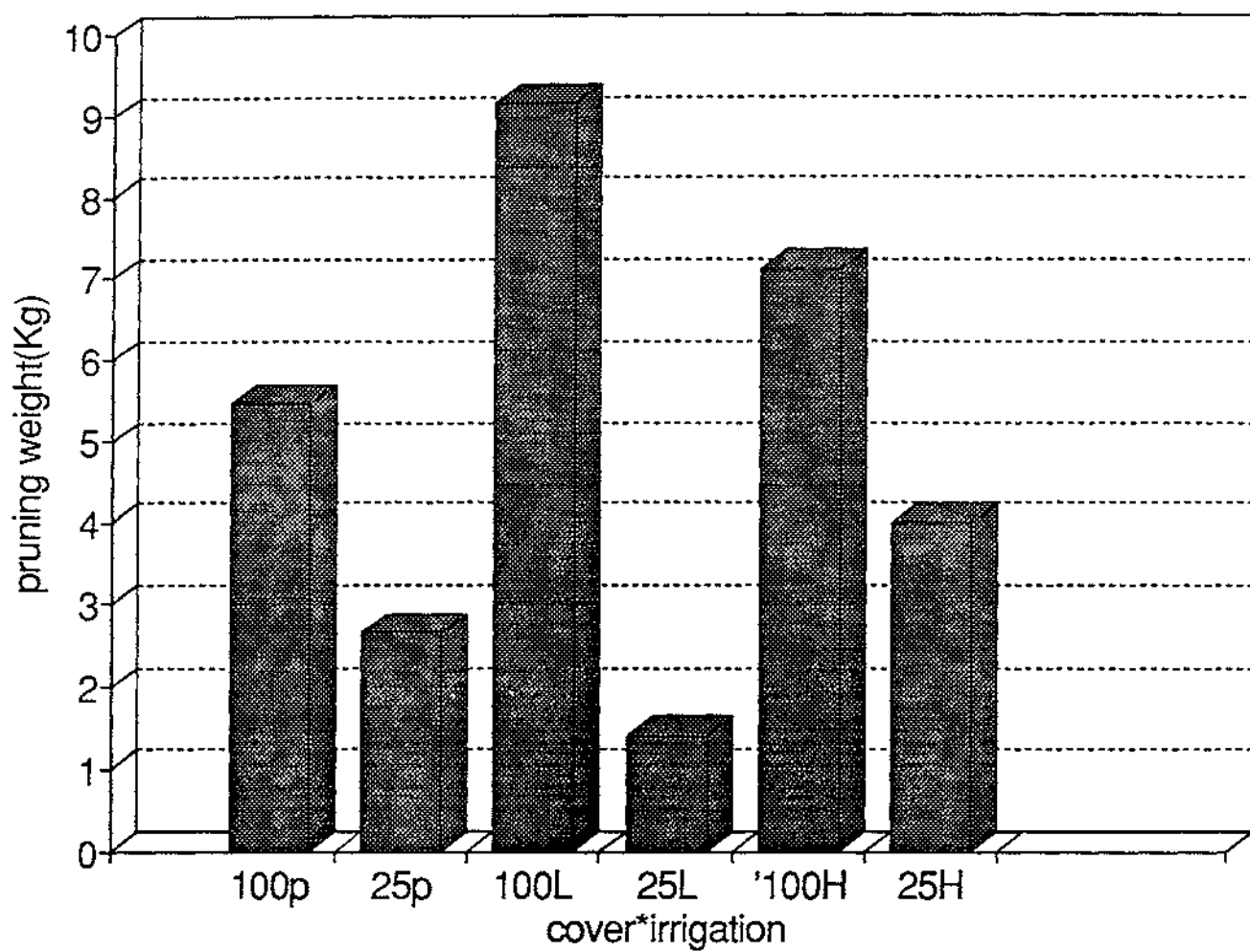

Figure 4.7 Pruning weights from HFI (100 H), HRDI (25 H), PFI (100 H), PRDI (25 P), LFI (100 L) and LRDI (25 L), taken in 1990.

Table 4.1 Firmness of Royal Gala apples at harvest and after 6 and 12 weeks at 2°C for Full Irrigation and RDI treatments in covers of Plastic, Lucerne and Herbicide

	Firmness (Neutons)					
	At harvest		6 weeks		12 weeks	
	Full Irrigation	RDI	Full Irrigation	RDI	Full Irrigation	RDI
Herbicide	56.1a	61.1b	45.0c	45.8c	37.4e	38.4e
Plastic	55.9a	60.3b	46.6c	45.6c	37.5e	38.4e
Lucerne	56.0a	61.5b	46.5c	48.3d	38.2e	39.9f
Mean	56.0	61.0	46.0	46.6	37.7	38.9

Values followed by a letter in common are not significantly different at 0.5%.

The fruit from Lucerne RDI trees attained the highest soluble solids content of all treatments after 12 weeks storage, being significantly higher than the other cover treatments with RDI (Table 4.2).

Table 4.2 Soluble solids on Royal Gala fruit at harvest and after 6 and 12 weeks at 0°C, from trees exposed to Full Irrigation and RDI treatments and different ground covers of Herbicide, Plastic and Lucerne.

	% Soluble solids Weeks at 2°C					
	At harvest		6		12	
	Full Irrigation	RDI	Full Irrigation	RDI	Full Irrigation	RDI
Herbicide	9.23a	10.83b	11.23c	12.25d	12.74d	13.24c
Plastic	9.24a	10.85b	11.34c	12.59d	12.81d	13.13c
Lucerne	9.19a	10.83b	11.37c	12.85d	12.89d	14.77f
Mean	9.22	10.84	11.31	12.56	12.81	13.82

Values followed by a letter in common are not significantly different at 0.5%.

4.2.5.3 Starch Index

Starch content decreased steadily during storage at 2°C (Table 4.3). At harvest fruit from RDI treatments had lower starch contents than fully irrigated fruit; this difference was maintained for 6 weeks, but disappeared after 12 weeks storage. There was no difference in starch levels between fruit from trees with different cover treatments.

Table 4.3 Starch index in Royal Gala fruit at harvest and after 6 and 12 weeks at 0°C from trees exposed to RDI and Full Irrigation treatments and ground covers of Herbicide, Plastic and Lucerne

	Starch Index					
	Weeks after harvest					
	At harvest		6		12	
	Full Irrigation	RDI	Full Irrigation	RDI	Full Irrigation	RDI
Herbicide	3.48a	2.65b	4.83c	3.95a	6.95d	6.93d
Plastic	3.06a	2.58b	4.23c	3.78a	6.93d	6.92d
Lucerne	3.33a	2.25b	4.56c	3.63a	6.95d	6.93d
Mean	3.29	2.49	4.54	3.79	6.95	6.93

Values followed by a letter in common are not significantly different at 0.5%.

4.2.5.4 Fruit Mineral

There was no consistent pattern of mineral content change following irrigation treatment. Phosphorus, calcium and magnesium levels were not influenced by irrigation and cover treatment. The highest Nitrogen was obtained in fruit from the PFI treatment and this was significantly greater than in fruit from the PRDI treatment. On the other hand, fruit from the HRDI treatments had higher nitrogen levels than fruit from the HFI treatment. Lowest nitrogen content was found in fruit from trees with the Lucerne cover crop, but there was no

difference between full irrigation and RDI treatments. Potassium was highest and significantly different in fruit from HRDI, LFI and PFI compared with fruit from LRDI, PRDI and HFI treatments (Table 4.4).

Table 4.4 Mineral content of Royal Gala apples from trees exposed to full irrigation and RDI treatments and different ground covers of Herbicide, Plastic and Lucerne. Three harvests represented in each record.

	Mineral content (mg/g dry matter)					
	HFI	HRDI	PFI	PRDI	LFI	LRDI
N	2.55a	2.74b	2.94c	2.70b	2.29d	2.21d
P	0.69a	0.66a	0.69a	0.65a	0.62a	0.63a
K	7.26a	7.90b	7.71b	7.36a	7.90b	7.44a
Ca	0.38a	0.35a	0.32a	0.31a	0.38a	0.31a
Mg	0.27a	0.27a	0.28a	0.25a	0.28a	0.25a

Values across columns (for each mineral) followed by letter in common are not significantly different at 5% level.

4.2.5.5 Colour

Fruit background colour changed from green to yellow with increasing time in storage (Table 4.5). Neither tree cover nor irrigation treatments had any effect on background colour either at harvest or during storage in this experiment.

Table 4.5 Ground colour of Royal Gala apples from trees exposed to full irrigation and RDI treatments and different ground covers of Herbicide, Plastic and Lucerne

	Ground colour in hue					
	Weeks in storage at 2°C					
	0		6		12	
	Full Irrigation	RDI	Full Irrigation	RDI	Full Irrigation	RDI
Herbicide	105.9a	105.6a	98.7b	98.2b	90.5c	90.3c
Plastic	105.8a	105.8a	98.5b	98.4b	90.5c	90.4c
Lucerne	106.2a	106.0a	98.5b	98.1b	90.6c	90.3c
Mean	105.9	105.8	98.6	98.2	90.5	90.3

Green colour is represented by the high values and the low values represent yellow fruit colour.

Values followed by a letter in common are not significantly different at 0.5%.

4.2 DISCUSSION

Fruit growth is known to be sensitive to plant water stress. Lack of irrigation of fruit trees in dry and humid climates has been shown to result in smaller fruit than fruit from adequately irrigated trees by many authors (Proebsting, 1970; Hewett, 1976; Assaf and Braudo, 1975). In this work, fruit size, as measured by diameter, increased regularly through the season in fully irrigated trees there being no effect of cover treatment on fruit size at harvest. Application of RDI treatments early in the season caused an immediate reduction in fruit growth rate between 60 and 70 days after bloom. The largest reduction in growth rate occurred with the Lucerne RDI combination, although the growth rate of fruit from all

treatments appeared to be similar to those of fruit from fully irrigated treatments between 100 and 135 days since bloom. On the resumption of full irrigation in the RDI treatments (113 days since bloom), there appeared to be a temporary surge in growth rate of fruit from herbicide and plastic RDI treatments and fruit from these treatments reached and remained at the same size as fruit from fully irrigated trees for the rest of the growing period. However, this did not occur with fruit from trees exposed to the Lucerne RDI treatment; resumption of a full irrigation regime did induce an increase in fruit growth rate, but fruit from this treatment never attained the same size as fruit from the fully irrigated Lucerne treatment.

Trees exposed to the Lucerne RDI treatment had a greater degree of water stress than trees with the herbicide or plastic RDI treatments. This was reflected in the lower leaf water potentials measured during the time when the RDI treatments were imposed early in the season. For example, in the period 70 to 85 dsb pre-dawn and midday ψ_l values for leaves from the fully irrigated lucerne treatment for Lucerne RDI leaves were -0.4 MPa and -1.0 MPa respectively, while ψ values from LRDI leaves were -0.9 MPa and -1.9 MPa respectively. A combination of the actual difference in the minimum ψ_l reached and the duration of stress probably account for the reduced fruit size in the Lucerne RDI trees compared with fruit from other treatments.

It is clear from these results that the RDI treatments and Lucerne RDI in particular, had positive and negative effects on fruit quality. Firmness, soluble solids and starch index were positively affected by RDI treatments which had no effect on mineral levels or background colour. On the other hand, fruit size was reduced by RDI, particularly by the

Lucerne RDI treatment. As the apple industry pays growers according to the size of fruit and will not accept fruit smaller than 150 size for export, then any treatment which induces smaller fruit is unacceptable.

CHAPTER 5

CONCLUSION

Application of regulated deficit irrigation (RDI) has been successful in peaches, pears and grapes in climates which experience insufficient rainfall during the growing season (Chalmers et al., 1981; Jerie et al., 1989; Goodwin and Jerie, 1989). RDI has resulted in a reduction of vegetative growth during the early part of the growing season with no lasting effect on fruit growth. Recommencement of irrigation later in the season allowed fruit growth to proceed normally with overall yields not being detrimentally affected by these stress treatments (Chalmers et al., 1984).

To achieve soil moisture deficits early in the growing season in major fruit growing areas in New Zealand, it will be necessary to develop some method to prevent water from entering the soil profile or else to create some system whereby the water in the soil is removed quickly in spring and early summer. New Zealand is regarded as a humid climate, the heavy rains that fall during the winter being sufficient to bring the orchard soils to field capacity. Rainfall is common in spring and early summer, so that some form of cover or moisture using cover crop, would have to be used to allow soil moisture deficit to occur during the critical phase of vegetative growth.

It proved possible to establish soil moisture deficits in the humid climate of Palmerston North by using plastic covers to exclude water, and by growing a lucerne cover crop known to be able to extract water from down the soil profile. In fact, the lowest soil moisture contents recorded during this experiment were in those plots receiving no irrigation early in the season with a lucerne cover crop (LRDI).

The most significant tree response to the RDI treatments was a reduction in fruit

size. This was measured both as a reduction of growth rate of the fruit and in the eventual size distribution of fruit following grading after harvest. There were more small fruit and less large fruit in the LRDI treatments than in the other RDI or FI treatments.

From fruit diameter measurements, it was observed that a marked reduction in fruit growth rate occurred at about 65 days after full bloom for all RDI treatments. This corresponded to a midday leaf water potential of about -1.8 MPa, which in turn corresponded to a soil moisture content of about 130 mm, which was 48.2% of the total water holding capacity of these soils.

Irrigation recommenced in the RDI treatments at 105 dsb when the midday ψ_1 was -1.8 MPa and the soil moisture content was 140 mm. Rate of fruit growth increased on relief from water stress at a faster rate in RDI treatments than was occurring on fruit from FI treatments. This increased rate occurred with HRDI and PRDI fruit for a short period only until fruit reached the size of those in the FI treatments after which the growth rates were the same in all treatments; the exception was for fruit from LRDI which never regained the same size as fruit from the LFI treatments. This marked change in fruit growth rate was similar to the responses obtained in pears, peaches and grapes (Chalmers et al., 1981; Mitchell et al., 1984; Goodwin and Jerie, 1989).

One of the major objectives of the RDI concept is to prevent or reduce shoot growth during the period of major fruit expansion (Chalmers, 1989). This should allow photosynthates produced in leaves to be diverted from a vegetative sink to the fruit sink. This undoubtedly occurred in Royal Gala fruit exposed to all RDI treatments as such fruit had

higher levels of soluble solids at harvest than fruit from fully irrigated treatments. It is possible that growth regulators such as gibberellins might also have been diverted to fruit (Miller, 1988). Gibberellins are known to reduce senescence in some plant systems. Fruit from RDI treatments were less mature at harvest than fruit from FI treatments as indicated by the starch iodine test.

Vegetative growth of Royal Gala trees was reduced in RDI treatments as compared to FI treatments when measured as weight of prunings. This is a relatively crude means of assessing shoot growth but it did indicate that those RDI treatments which experienced the greatest ψ_1 (i.e. LRDI and PRDI) also had the least prunings. As shoot length measurements were not taken during the season, it is not possible to relate cessation or reduction in growth rate to ψ_1 . However, Chalmers et al. (1986) showed that shoot growth in pears ceased when dawn and midday ψ_1 values reached -0.57 and -2.22 MPa, respectively. This degree of water stress did not occur in this experiment but as shoot growth was obviously reduced by RDI treatments it is clear that the maximum ψ_1 measured were sufficient to reduce shoot growth.

The combination of lucerne and RDI obviously has potential for selectively inducing water stress in trees during the early part of the season, but more research is required to fine-tune the technique to slightly reduce the negative effect of this treatment on fruit size, for example, regular mowing of the lucerne throughout the season may reduce its capacity to withdraw water from the soil. Alternatively, a different type of cover crop with a less capacity to draw water from throughout the soil profile might be preferable to lucerne.

This work has demonstrated that in humid climates it is possible to bring down soil

moisture content using a combination of RDI and cover crops or polythene mulch. The high cost of polythene would be a strong deterrent to its being used by many orchardists (except perhaps in very special conditions).

It is clearly possible to influence the availability of water to tree roots by planting a competitive cover crop. Lucerne was very effective in removing water from the soil profile and consequently, in combination with RDI inducing maximum ψ_1 which in turn significantly reduced fruit size - a major commercial disadvantage. Further, research is needed to find an appropriate type of grass or legume which is slightly less effective than lucerne, in withdrawing water from the soil profile but which has an extensive and deep enough root system that can influence soil moisture, and thus ψ_1 to a degree which reduces vegetative growth but has minimal effect on rate of fruit growth. Searching for such a plant would be a worthwhile objective.

REFERENCES

- Acevedo, E., Hsaio, T.C. and Henderson, D.W. (1971). Immediate and subsequent growth response of maize leaves to change in water status. Plant Physiol. 48: 631-636.
- Adato, I. and Levison, B. (1988). Influences of daily intermittent drip irrigation on avocado (cv. Fuerte) fruit yield and trunk growth. J. Hort. Sci. 63(4): 675-685.
- Al-Ani, J.A. and Bierhuizen, J.F. (1971). Stomatal resistance, transpiration and relative water content as influenced by soil moisture stress. Acta Bio. Neerl. 20(3): 318-325.
- Amen, K.I., Mika, A. and Piatkowski, M. (1983). Fruit quality and storage ability of two apple cultivars as affected by rootstocks, planting systems, irrigation and growth retardants. Part I. Effect of orchard treatments on fruit quality and mineral nutrition. Fruit Sci. Reports 10: 161-172.
- Assaf, R.I. and Bravdo, B. (1975). Effects of irrigation on trunk and fruit growth rates, quality and yield of apple. J. Hort Sci. 50: 481-493.
- Assaf, R., Bravdo, B. and Levin, I. (1974). Effect of irrigation according to water deficit in two different soil layers on the yield and growth of apple trees. J. Hort Sci. 49: 53-64.
- Bacon, P. (1974). More fruit with polyethylene mulch. Agric. Gaz. (NSW) 85: 74.
- Barrs, H.D. (1968). Determination of water deficits in plant tissues. In: Water Deficits and Plant Growth. (ed. T.T. Kozlowski), pp. 235-268. Academic Press, New York.

- Ben Arie, R. and Lurie, S. (1986). Prolongation of fruit life after harvest. In: Handbook of Fruit Set and Development. (ed. S.P. Monselise). CRC Press Inc, Boca Raton, Florida.
- Beukes, D.J. and Weber, H.W. (1982). The effects of irrigation at different soil water levels on the water use characteristics of apple trees. J. Hort Sci. 57(4): 383-391.
- Boyer, J.S. (1967). Leaf water potential measured with a pressure chamber. Plant Physiol. 42: 133-137.
- Boyer, J.S. (1969). Measurement of the water status of plants. Ann. Rev. Plant Physiol. 20: 35-365.
- Bramlage, W.J., Weis, S.A. and Drake, M. (1985). Predicting the occurrence of poststorage disorders of 'McIntosh' apples from preharvest mineral analysis. J. Amer. Soc. Hort. Sci. 110(4): 493-498.
- Bresler, E. (1977). Trickle-drip irrigation; principles and applications to soil-water management. Adv. Agron. 29: 343-393.
- Buss, P. (1989). Irrigation scheduling for horticulture an integrated approach. Acta Hort. 240: 261-265.

- Campbell, G.S. and Campbell, M.D. (1982). Irrigation scheduling using soil moisture measurements: theory and practice. In: Advances in Irrigation, Vol. 1. (ed. Hillel), pp. 25-42. Academic Press, New York.
- Chalmers, D.J. (1989). A physiological examination of regulated deficit irrigation. N.Z. Agric. Sci. 23: 44-48.
- Chalmers, D.J., Burge, G., Jerie, P.H. and Mitchell, P.D. (1986). The mechanism of 'Bartlett' pear fruit and vegetative growth by irrigation withholding and regulated deficit irrigation. J. Amer. Soc. Hort. Sci. 111(6): 904-907.
- Chalmers, D.J., Mitchell, P.D. and Jerie, P.H. (1984). The physiology of growth control of peach and pear tree using reduced irrigation. Acta Hort. 146: 143-149.
- Chalmers, D.J., Mitchell, P.D. and Jerie, P.H. (1984). Break the rules and boost the orchard \$\$\$ Australian Country 2(4): 54-59.
- Chalmers, D.J., Mitchell, P.D. and van Heek, L.A.G. (1981). Control of peach tree growth and productivity by regulated water supply, tree density and summer pruning. J. Amer. Soc. Hort. Sci. 106(3): 307-312.
- Clothier, B.E. (1976). Moisture retention in a layered soil. Proc. Soil Plant Water Symp.: 18-20.

- Clothier, B.E., Snow, V., Green, S., Saver, T., Nicholson, Gander, P., Trough, M., Hughes, K. and Lok, J. (1987). Water economy of kiwifruit vines. pp. 16-19, NZKA Res. Conference.
- Denmead, O.T. and Shaw, R.H. (1962). Availability of soil water to plants as affected by soil moisture content and meteorological conditions. Agron. J. 54: 385-390.
- Doichev, K. (1977). Root distribution of M7 clonal apple rootstock grafted with Golden Delicious as affected by different methods and rates of irrigation. Grad. Lozas. Nauka. 14: 19-24.
- Doorenbos, J. and Pruitt, W.O. (1977). Crop water requirements. FAO Irrig. Drain Pap. 24: 85-146.
- Duniway, J.M. (1971). Comparison of pressure chamber and thermocouple psychrometer determinations of leaf water status in tomato. Plant Physiol. 48: 166-207.
- Durand, G. (1990). Effects of RDI on apple tree (cv. Royal Gala) growth, yield and fruit quality in a humid environment. Ph.D. Thesis, Massey University.
- Erf, J.A. and Proctor, J.T.A. (1987). Changes in apple leaf water status and vegetative growth as influenced by crop load. J. Amer. Soc. Hort. Sci. 112(4): 617-620.
- Fochessatti, A. (1986). Water management in orchards. Deciduous Fruit Grower 16: 131-136.

- Francis, F.J. (1980). Colour quality evaluation of horticultural crops. Hort. Sci. 15(1): 58-59.
- Gandar, P.W. and Tanner, C.B. (1976). Leaf growth, tuber growth and water potential in potatoes. Crop Sci. 16: 534-538.
- Gardner, W.R. (1960). Dynamic aspects of water availability to plants. Soil Sci. 89: 63-73.
- Garnier, E. and Berger, A. (1987). The influence of drought on stomatal conductance and water potential on peach tree growing in the field. Scientia Horticulturae 32: 249-269.
- Garnier, E.A., Berger, A. and Rambal, S. (1986). Water balance and pattern of soil water uptake in a peach orchard. Agric. Water Management 11: 145-158.
- Glenn, D.M. and Welker, W.V. (1991). Soil management affects shoot and root growth, nutrient availability and water uptake of young peach trees. J. Amer. Soc. Hort. Sci. 116(2): 238-241.
- Goode, J.E. (1972). The cumulative effects of irrigation on temperate fruit crops and some recent studies on the water relationships of apple trees. Proc. 18th Int. Hort. Congr., Israel: 187-193.
- Goode, J.E. and Higgs, K.H. (1973). Water, osmotic and pressure potential relationships in apple leaves. J. Hort. Sci. 48: 203-215.

- Goode, J.E., Higgs, K.H. and Hyrycz, K.J. (1978a). Nitrogen and water effects on the nutrition, growth, crop yield and fruit quality of orchard grown Cox's Orange Pippin apple trees. J. Hort. Sci. 53: 295-306.
- Goode, J.E., Higgs, K.H. and Hyrycz, K.J. (1978b). Trickle irrigation of trees and the effect of liquid feeding with NO_3 and K^+ compared with normal manuring. J. Hort. Sci. 53: 307-316.
- Goode, J.E. and Hyrycz, K.J. (1964). The response of Laxton's Superb apple tree to different soil moisture conditions. J. Hort. Sci. 39: 254-274.
- Goode, J.E. and Hyrycz, K.J. (1970). The response of black currants to different soil moisture conditions and two levels of nitrogenous fertilizer. J. Hort. Sci. 45: 379-391.
- Goode, J.E. and Ingram, I. (1971). The effect of irrigation on the growth, cropping and nutrition of Cox's Orange Pippin apple trees. J. Hort. Sci. 46: 195-208.
- Goodspeed, M.J. (1981). Neutron moisture meter theory. In: Soil-water assessment by the neutron probe method. (L.E. Greacen). CSIRO, Australia.
- Goodwin, L. and Jerie, P. (1989). Deficit irrigation of chardonnay grapevines during flowering. Acta Hort. 240: 275-278.
- Greacen, L.E. (1981). Soil-water assessment by the neutron probe method. CSIRO, Australia.

- Greacen, L.E. and Oh, J.S. (1972). Physics of root growth. Nature (London) New Biol. 235: 24-25.
- Guelfat'Reich, S. and Ben-Arie, R. (1979). Effects of irrigation on fruit quality at harvest and during storage. Proc. XVth Int. Congr. of Refrigeration 3: 423-427.
- Guelfat'Reich, S., Assaf, R., Bravdo, B.A. and Levin, I. (1974). The keeping quality of apple in storage as affected by different irrigation regimes. J. Hort. Sci. 49: 217-225.
- Hanan, J.J. (1972). Repercussions of water stress. Hort. Sci. 7: 108-111.
- Hanks, R.J. and Ashcroft, G.L. (1980). Irrigation scheduling for horticulture on irrigated approach. Acta Hort. 240: 261-265.
- Hayman, J.M. and McBride, S.D. (1984). The response of pasture and lucerne to irrigation. Tech. Rept. Winchmore Irrig. St. 17: 37-40.
- Henrickson, A.H. and Veihmeyer, F.J. (1942). Readily available soil moisture and size of fruits. Proc. Amer. Soc. Hort. Sci. 40: 13-18.
- Hewett, E.W. (1976). Irrigation of apple trees in Nelson. N.Z. J. Agric. Res. 19: 505-511.
- Hilgeman, R.H., Tucker, H. and Halls, T.A. (1959). The effect of temperature, precipitation, bloom date and yield upon tree enlargement of valencia orange. Proc. Amer. Soc. Hort. Sci. 74: 266-279.

- Hilgeman, R.H. (1972). Irrigation of 'Valencia orange' by wetting alternate sides. Cong. Mond. Citric. 1: 265-269.
- Hillel, D. (1980). Applications of soil physics. Academic Press, New York.
- Hillel, D. (1982). Introduction to soil physics. Academic Press, New York.
- Hillel, D. and Guron, Y. (1973). Relation between evapotranspiration rate and maize yield. Water Resources Res. 9: 743-748.
- Huguet, J.G. (1973). New method of studying the rooting of perennial plants by means of a spiral trench. Ann. Agron. 24: 707-731.
- Hsaio, T.C. (1973). Plant responses to water stress. Ann. Rev. Plant Physiol. 24: 519-570.
- Hsaio, T.C., Acevedo, E., Fereres, D.C. and Henderson, D.W. (1976). Water stress and dynamics of growth and yield of crop plants. Ecol. Stud. 19: 281-305.
- Irving, D.E. and Drost, J.H. (1987). Effect of water deficit on vegetative growth, fruit growth and fruit quality in Cox's Orange Pippin apple. J. Hort. Sci. 62(4): 427-432.
- Jackson, J.E. and Palmer, J.W. (1977a). The effect of shade on the growth and cropping of apple trees. II. Effects on components of yield. J. Hort. Sci. 52: 253-266.

- Jackson, J.E., Palmer, J.W., Perring, M.A. and Sharples, R.O. (1977b). Effects of shade on the growth and cropping of apple trees. III. Effects on fruit growth, chemical composition and quality at harvest and after storage. J. Hort. Sci. 52: 267-282.
- Jackson, J.E., Sharples, R.O. and Palmer, J.W. (1971). The influence of shade and within tree position on apple fruit size, colour and storage. J. Hort. Sci. 46: 277-287.
- Jensen, M.E., Rob, D.C.N. and Franzoy, C.E. (1970). Scheduling irrigations using climate-crop-soil data. Proc. Amer. Soc. Civ. Eng. J. Irrig. Drain Div. 96: 25-38.
- Jerie, P.H., Mitchell, P.D. and Goodwin, I. (1989). Growth of 'William' Bon Chretien pear under regulated deficit irrigation (RDI). Acta Hort. 240: 27-274.
- Kramer, P.J. (1983). Water relations of plants. Academic Press Inc., San Diego, USA.
- Lahow, E. and Kalmar, D. (1982). Determination of irrigation regimes for avocado in spring and autumn. Alon. Honotea 39(9): 1-11.
- Lahow, R.I. and Kalmar, D. (1972). The value of physiological indicators for planning irrigation of avocado trees. Preliminary Rep. Volcan. Inst. of Agric. Res.
- Levin, I., Assaf, R. and Bravdo, B. (1980). Irrigation water status and nutrient uptake in an apple orchard. In: The Mineral Nutrition of Fruit Trees. (eds D. Atkinson, J.E. Jackson, R.O. Sharples and W.M. Welker). Butterworths, Broough Green, U.K.

- Lotter, J.de V., Beukes, D.J. and Webber, H.W. (1985). Growth and quality of apples as affected by different irrigation treatments. J. Hort. Sci. 60(2): 181-192.
- Mage, F. (1982). Black plastic mulching, compared to other orchard soil management methods. Scientia Horticulturae 16: 131-136.
- McAuliffe, K. (1985). An investigation into soil properties relevant to horticultural irrigation at a number of lower North Island sites. Massey University Research Publication, 911-941.
- Miller, D.E. and Gardner, W.H. (1962). Water infiltration into stratified soil. Soil Sci. Soc. Ann. Proc. 26: 115-118.
- Miller, S.S. (1988). Plant bioregulators in apple and pear culture. Hort. Rev. 10: 310-380.
- Mitchell, P.D. and Chalmers, D.J. (1982). The effect of reduced water supply on peach tree growth and yield. J. Amer. Soc. Hort. Sci. 107: 853-856.
- Mitchell, P.D. and Chalmers, D.J. (1983). A comparison of microjet and point emitter (trickle) irrigation in the establishment of a high density peach orchard. Hort. Sci. 18(3): 472-474.
- Mitchell, P.D., Jerie, P.H. and Chalmers, D.J. (1984). The effect of regulated water deficit on pear tree growth, flowering, fruit growth and yield. J. Amer. Soc.

- Molz, F.J. (1976). Water transport in the soil-root system. Transient analysis. Water Resour.Res. 12: 805-807.
- Morgan, D.C., Stanley, C.J., Volz, R.K. and Warrington, I.J. (1984). Summer pruning of "Gala" apple: the relationships between pruning time and radiation penetration and fruit quality. J. Amer. Soc. Hortic. Sci. 109: 637-642.
- Morris, J.R., Kattan, A.A. and Arrington, O.H. (1962). Response of Elberta peaches to the interactive effects of irrigation, pruning and training. Proc. Amer. Soc. Hort. Sci. 80: 177-189.
- Olsson, K.A. and Milthorpe, F.L. (1983). Diurnal and spatial variation in leaf conductance of irrigated peach trees. Austr. J. Plant Pysiol. 10: 219-298.
- Penman, H.L. (1949). The dependence of transpiration on weather and soil conditions. J. Soil Sci. 1: 74-89.
- Philip, J.R. (1966). Plant water relationships: some physical aspects. Ann. Rev. Plant Physiol. 17: 245-268.
- Ponder, J.J. and Kenworthy, A.L. (1976). Trickle irrigation of shade trees growing in the nursery. II. Influence on root distribution. J. Amer. Soc. Hort. Sci. 101: 104-107.
- Proebsting, E.L., Drake, S.R. and Evans, R.G. (1984). Irrigation management, fruit quality and storage life of apples. J. Amer. Soc. Hort. Sci. 109(2): 229-232.

- Proebsting, E.L. (1970). Soil management in relation to fruit quality. Proc. 18th Int. Hort. Congr., Vol. IV: 223-239.
- Rahardjo, P. (1989). Soil water use by apple trees. M.Sc. Thesis, Massey University, New Zealand.
- Rawitz, E. (1969). The dependence of growth rate and transpiration on plant and soil physical parameters under controlled conditions. Soil Sci. 110: 172-182.
- Reid, M.S. (1975). The role of ethylene in the ripening of some unusual fruits. In: Facteurs et regulation de la maturation des fruits, Colloques Internationaux du Centre National de la Recherche Sci. No. 238: 177-182.
- Richards, D. and Rowe, R.W. (1977). Root shoot interactions in peach: the function of the root. Ann. Bot. 41: 1211-1216.
- Ritchie, J.I. (1981). Water dynamics in the soil-plant-atmosphere system. Plant Soil 58: 81-96.
- Sanders, D.C., Howell, T.A., Hile, M.M.S., Hughes, L., Meek, D. and Phene, C.J. (1989). Yield and quality of processing tomatoes in response to irrigation rate and schedule. J. Amer. Soc. Hort. Sci. 114(6): 904-908.
- Sharma, M.L. (1985). Estimating evapotranspiration. In: Advances in Irrigation, Vol. 3. (ed. D. Hillel)., pp. 213-218. Academic Press, New York.

- Shirazi, G.A. and Isobe, M. (1972). Calibration of neutron probe in some selected Hawaiian soils. Soil Sci. 122(3): 163-170.
- Smart, R.E. and Barrs, H.D. (1973). The effect of environment and irrigation interval on leaf water potential of four horticultural species. Agric. Meteorol. 12: 337-346.
- Smock, R.M. (1948). A study of maturity indices for McIntosh apples. Proc. Amer. Soc. Hort. Sci. 52: 176-182.
- Sidorenko, V.M. (1973). The characteristics of distribution of the root system of apple trees in relation to soil management and irrigation. Yuzhnoc. Stepnol. Sadovodstvo.: 98-103.
- Takagi, S. (1960). Analyses of the vertical downward flow of water through a two-layered soil. Soil Sci. 90: 98-103.
- Taylor, A. (1974). Trickle irrigation experiments in the Goulburn Valley, Vic. Hort. Dig. 61: 4-8.
- Tiller, L.W. (1934). The iodine-starch reaction as a test for measuring maturity of apples. N.Z.J. Sci. Tech. 16: 88-101.
- Twine, J.R. and Williams, C.H. (1971). The determination of phosphorus in Kjeldahl digests of plant material by automatic analysis. Comm. Soil. Sci. Plant Anal. 2: 485-489.

- van Bavel, C.H.M. and Hillel, D. (1976). Calculating potential and actual evaporation from a bare soil surface by simulation of concurrent flow of water and heat. Agric. Meteorol. 17: 453-476.
- Vermeiren, L.G. and Jobling, A. (1984). Localized irrigation, design, installation, operation, evaluation. FAO Irrig. and Drain Paper 36: 9-29.
- Visvalingam, M. and Tandy, J.D. (1972). The neutron method for measuring soil moisture content. A review. J. Soil Soc. 23(4): 499-511.
- Waring, R.H. and Cleary, B.D. (1967). Plant moisture stress - Evaluation by pressure bomb. Sci. 155: 1248, 1253, 1254.
- Yakushev, V.I. (1972). Assymetry in the development of apple roots. Vest. Sel'kohk. Namki.17(8): 84-88.