

Copyright is owned by the Author of the thesis. Permission is given for a copy to be downloaded by an individual for the purpose of research and private study only. The thesis may not be reproduced elsewhere without the permission of the Author.

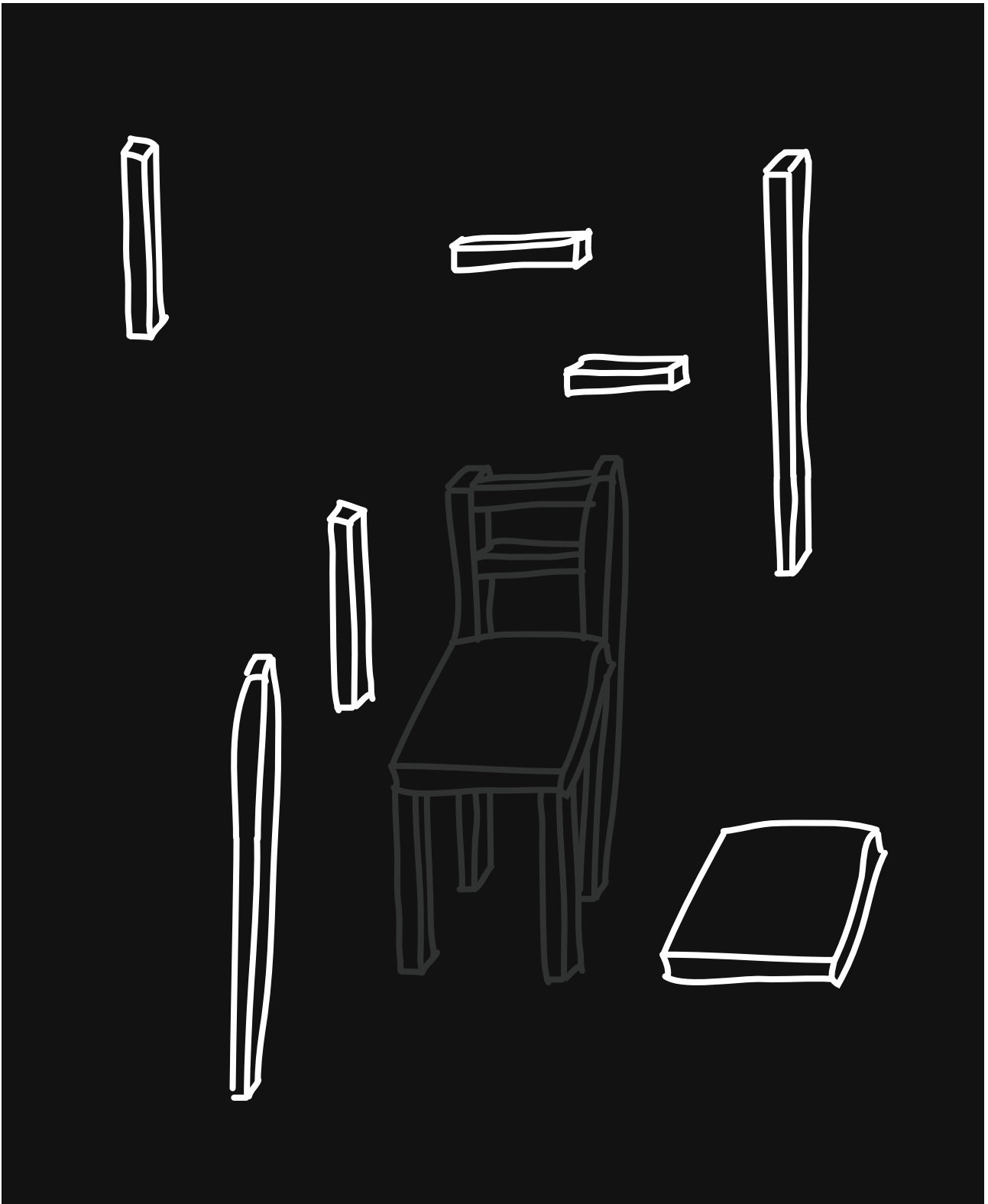

An open invitation to design

2013

By Nicholas Robert Graham

An exegesis presented in partial fulfillment of the requirements for the degree of Master of Design. Massey University, College Of Creative Arts, Wellington, New Zealand.

This exegesis is
open and bears **four**
freedoms.

Please make use of the refill located
throughout this exegesis to jot down your
thoughts, comments and sketches relating
to this document.

One. The freedom to use this exegesis, for any purpose. **Two.** The freedom to change it to make it do what you wish.

Three. The freedom to redistribute copies of this exegesis so you can help your neighbour. **Four.** The freedom to distribute copies of your modified versions of the exegesis to others so the whole community can benefit from your changes.
(Katz, 2011, p.62).

Acknowledgments.

First and foremost I would like to acknowledge my supervisors, Chris Jackson and Stuart Foster. Not only for their insight into the field of Open Design but also for the opportunities that they have offered me throughout my years here at Massey. You're both gold, thank you.

I would also like to acknowledge those who participated in my projects, those who discussed my work over a coffee or two and especially those who questioned what I was doing, at all stages, even if you knew they weren't the questions I wanted to hear. Thank you for your honest critique.

To Jonti Griffin at 1989 - thank you. You've been able to encapsulate the ideas behind this research into the graphic design of this document so superbly.

Mum, for being the one to bring this family together, at times when we were all heading in different directions. I know it hasn't been the easiest of tasks over the last few years, but your efforts haven't gone unnoticed, I mightn't have said it enough this year but I love you.

To Steph – hearing your stories about travel and pints served at pubs in the sticks has been more than motivation to finish this research and come and join you as soon as I can. Although you always seem to be on the opposite side of the planet, you'll always be close, no matter how much of a gypsy you are.

Finally, thanks to the unfailing support of my Dad, for his superhuman efforts and encouragement that began in the garage and garden shed, years before Massey when I still thought I was Batman. I would not have been able to accomplish what I have, had it not been for you all.

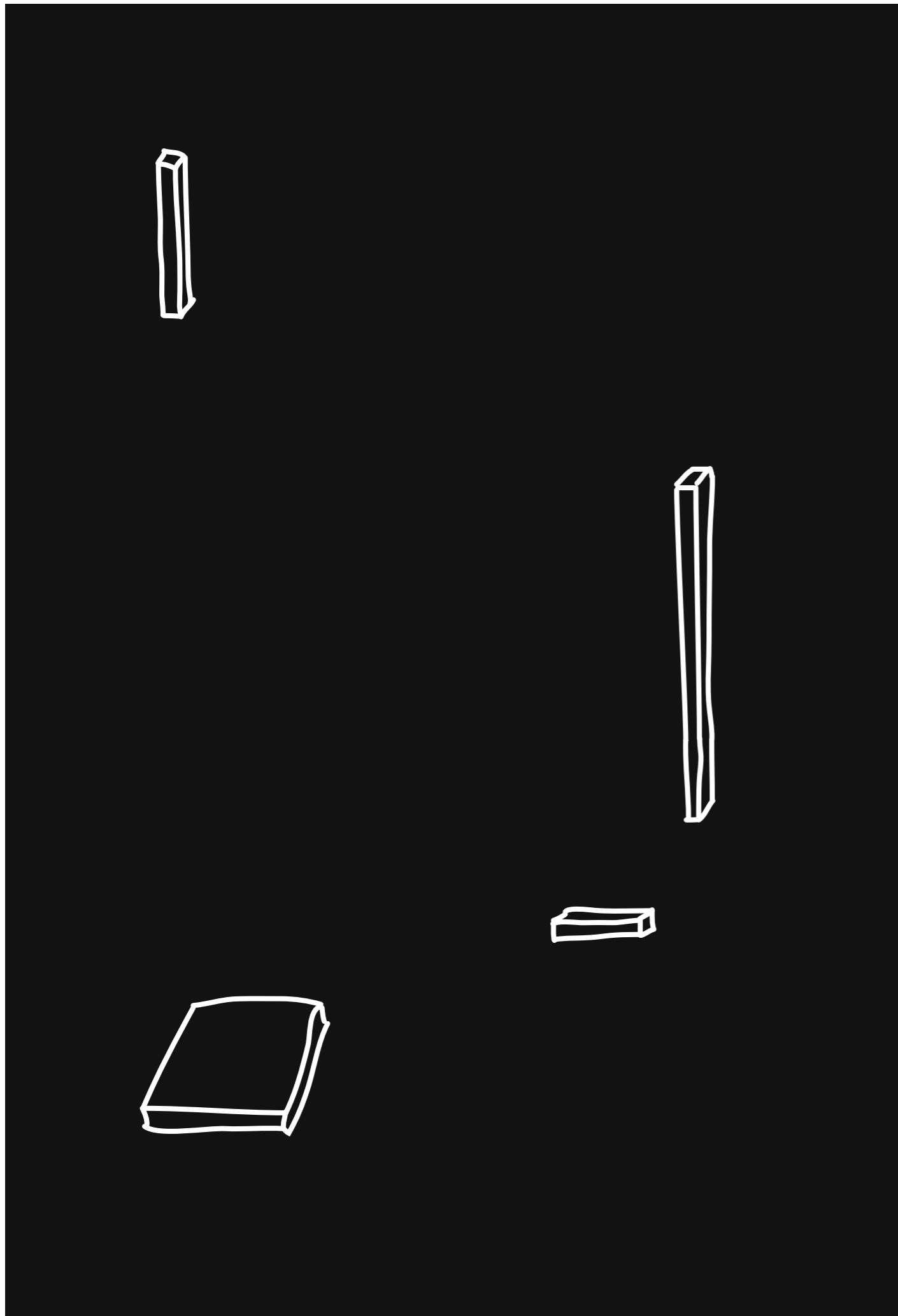

Abstract.

An Open Invitation to Design is a design-led research project that explores the areas of collaboration, authorship and derivative design, associated with digital fabrication technologies and communication networks in the context of Open Design. It specifically serves as a critique of the Open Design process and aims to demonstrate the design potential of using open source methods as a generative element of design innovation.

Nick Graham 2013

About the author.

As an industrial designer, I have many preconceptions and assumptions about design; these have grown out of my personal experiences and design surroundings. Throughout this project I have been made aware of this more so than ever. Therefore, this exegesis also acts as documentation of the effects Open Design has had on my personal design practice.

I occasionally write in first person as a way to reflect on these effects.

Contents

Definitions	01
<hr/>	
Introduction	05
Open Design	06
Collaboration	08
<hr/>	
Process	
Technology Experimentation	11
Sedia Mutant	15
Layer Stool	19
Referencing Design DNA	21
EC Chair	29
An Open Invitation to Design	37
<hr/>	
Conclusion	45
<hr/>	
Reference List	59
<hr/>	
Figure List	61
<hr/>	
Appendix	
Ethics	62
<hr/>	

Definitions.

Throughout this exegegesis there are three recurring key terms; **Derivative**, **Authorship** and **Collaboration**. What follows is a brief description on how each term is defined in relation to Open Design and this exegegesis.

Derivative. Is the result of a adaptation based upon one or more pre-existing works, it is a design or work consisting of modifications or alterations that, still represent an original or parent work.

Authorship. Refers to the source of an object, design or derivative. The author may be an industrial designer, a computer programmer or a 10 year old constructing a Lego robot.

Collaboration. Refers to any act of collective creativity, shared by two people or more. Collaboration is a very broad term with applications ranging from the physical to the digital (Sanders & Stappers, 2008, p.2). “It is based on sharing resources and outputs among widely distributed, loosely connected individuals” (Benkler, 2006, p.60).

Introduction.

As a newly graduated industrial designer about to begin my masters, I read a statement from the CEO of MakerBot, Bre Prettis (as cited in Kelion, 2012); "I don't think we need a marketplace. It's a sharing world. We are at the dawn of the age of sharing where even if you try to sell things the world is going to share it anyway." Now sitting at the opposite end of this project, I realize it was almost a sense of fear at being a designer exposed to this "sharing world" that drew me to this research. For four years I had been primed to pitch products and design what the users needed. This was all beginning to seem irrelevant with the onset of Open Design.

Open design.

First coined in 1998 by Dr. Sepehr Kiani (Vallance, 2000), Open Design has grown out of the Open Source Software movement of the late 1970's/early 1980's (Stallman, 1999). The explosion of today's digital culture and web 2.0 has influenced the uptake of this new design movement. "The World Wide Web not only initiated a dialogue among consumers; it also started a conversation between consumers and producers" (Lom e, 2011).

Open Design is an area of design that is relatively new. It is not "a clear cut ideology, but has many different manifestations" and draws from multiple disciplines (Junte, 2012, p.8). It is a journey to discover the best of both a top-down visionary design practice attempting to define systems (such as Industrial Design, Figure 1) and hacking, a bottom-up visionary practice attempting to introduce rapture and creative disturbance into these designed systems (Aviv, 2011).

The principles and tools of Open Design enable people to become producers, as well as users, of a new generation of products shaped and molded by the group. It will enable people to once again be more hands-on in an era where many activities are screen based. As the knowledge to design and make objects becomes more readily available and disseminated, the role of the designer is set to diversify. Katz (2011) offers one of the most succinct definitions a designer can work with to create an Open Design:

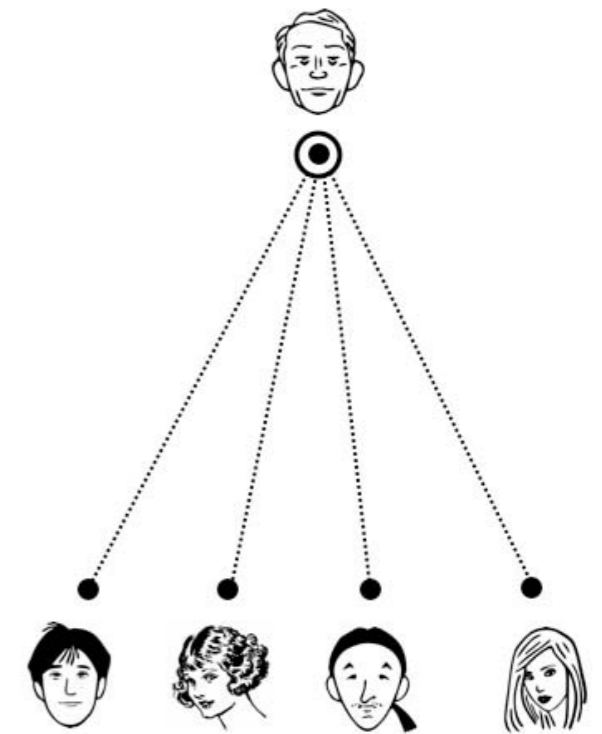

Figure 1: Closed modular systems. Open Structures. 2012.

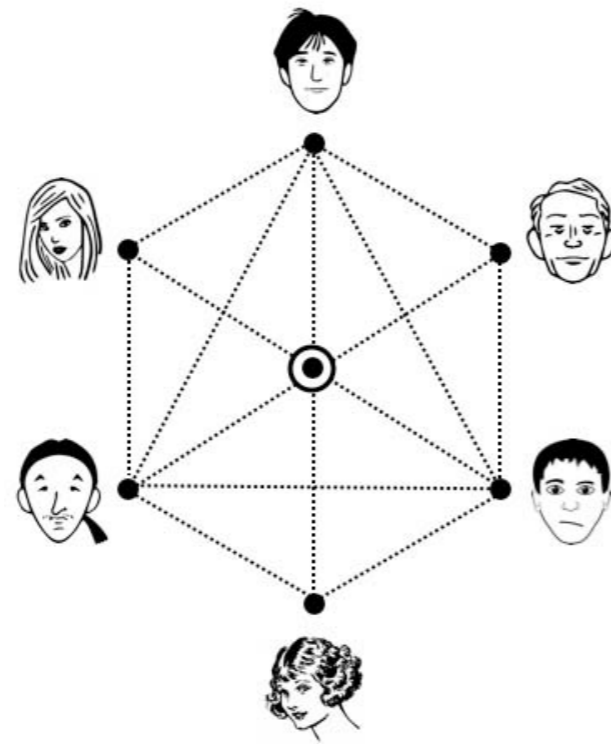

Figure 2: Open modular systems. Open Structures. 2012.

A design is open if it bears four freedoms. One: The freedom to use the design, including making items based on it, for any purpose. Two: The freedom to study how the design works, and change it to make it do what you wish. Three: The freedom to redistribute copies of the design so you can help your neighbour. Four: The freedom to distribute copies of your modified versions of the design to others so the whole community can benefit from your changes. Access to the design documents is a precondition for these freedoms (p. 62).

These freedoms will undoubtedly encourage people to hack and create derivatives from a design for their benefit. This confronts the control that designers have over their work. If we work with this definition as a guide for designing, how will we adapt to dealing with derivatives of our own work? Would we encourage anyone to collaborate with us, maybe even without us, letting him or her become co-authors of our work?

Collaboration.

“For most of the 20th century we believed new ideas and developments sprang from the individual creative talent” (Dexter, and Jackson, 2012, p.1). With the freedoms that Open Design brings, we can begin to stimulate collaboration between industries, designers and previously unrelated disciplines but most importantly, collaboration between the professional and the amateur.

Extensive documentation exists on the benefits of involving the ‘end user’ in a product’s design, as seen in *Sketching User Experiences* by Bill Buxton or *The Design of Everyday Things* by Donald Norman. Co-design projects are nothing new and attempt to give the consumer greater influence over the product’s they buy. Established in 1999, *NikeiD* is an example of such a project. This online interaction allows consumers to tailor a ‘template’ i.e. a standard Nike trainer, offering the choice of varying colors, sizes and styles of specific shoes.

Tom Dixon partnered with Digital Forming at the MOST Salone in Milan Furniture Fair, to offer a co-design platform allowing members of the public to design their own bespoke Tom Dixon product. This design interaction was however limited to the “push and pull” of lines (Dixon, 2012). As Dexter and Jackson state; “One should be wary of what could be viewed as more traditional, hierarchical design model subverting or diluting a progressive, future-facing paradigm” (2012, p.2).

This mass customization allows the consumer to use pre-defined elements to construct something that they feel will be the most aesthetic or functional combination. Open Design collaboration gives the participant the same options along with the ability to fabricate their own elements.

The proactive consumer no longer judges an object for what it is but rather imagines what it could become, and the objects themselves are starting to behave more and more like dynamic puzzles, self-improving product versions rather than rigid monoliths (Lommée, 2011).

With this statement in mind, my research goals are to illustrate how designers can adapt to this ever-changing environment and carve out new niches for the future, working in more collaborative and creative ways. In the words of Jos De Mul, in the shift from designing products to designing processes, one becomes along the way a ‘Meta Designer’ (2011, p.36).

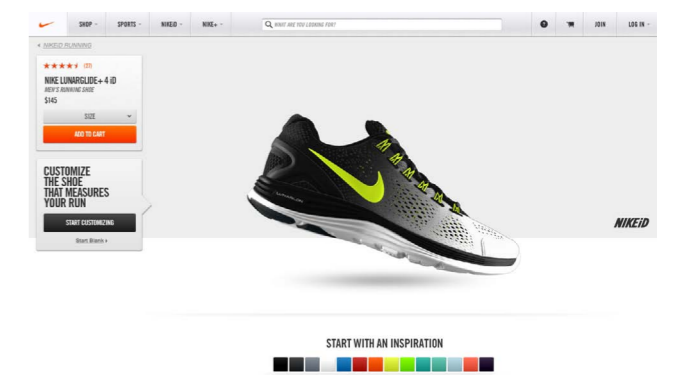
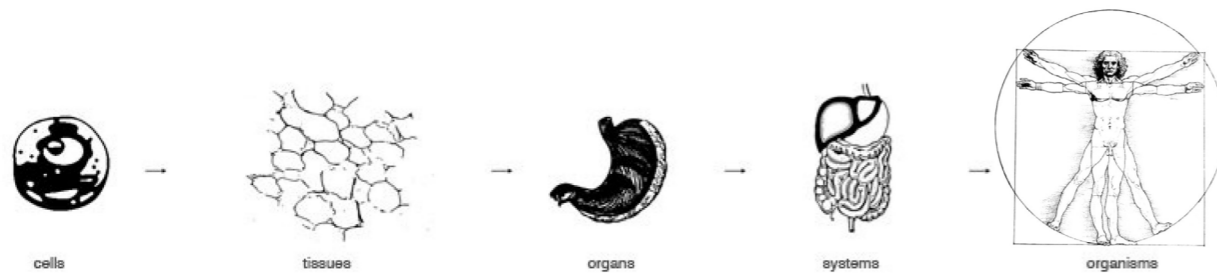
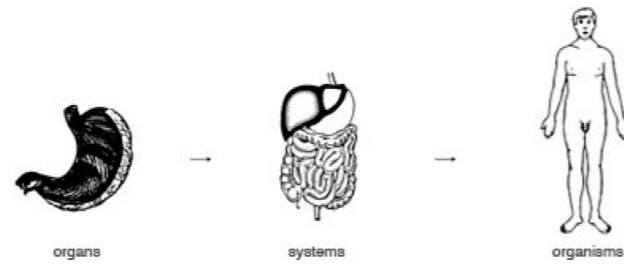

Figure 3: Nike iD customization app. Nike. 2012.

Mass customization

Offers pre defined elements that can be assembled in to a product.



Open Design

Allows people to build their own elements that can then be put into their product. **Figure 4:** Mass customization vs Open Design. Derived from Open Structures. 2012.

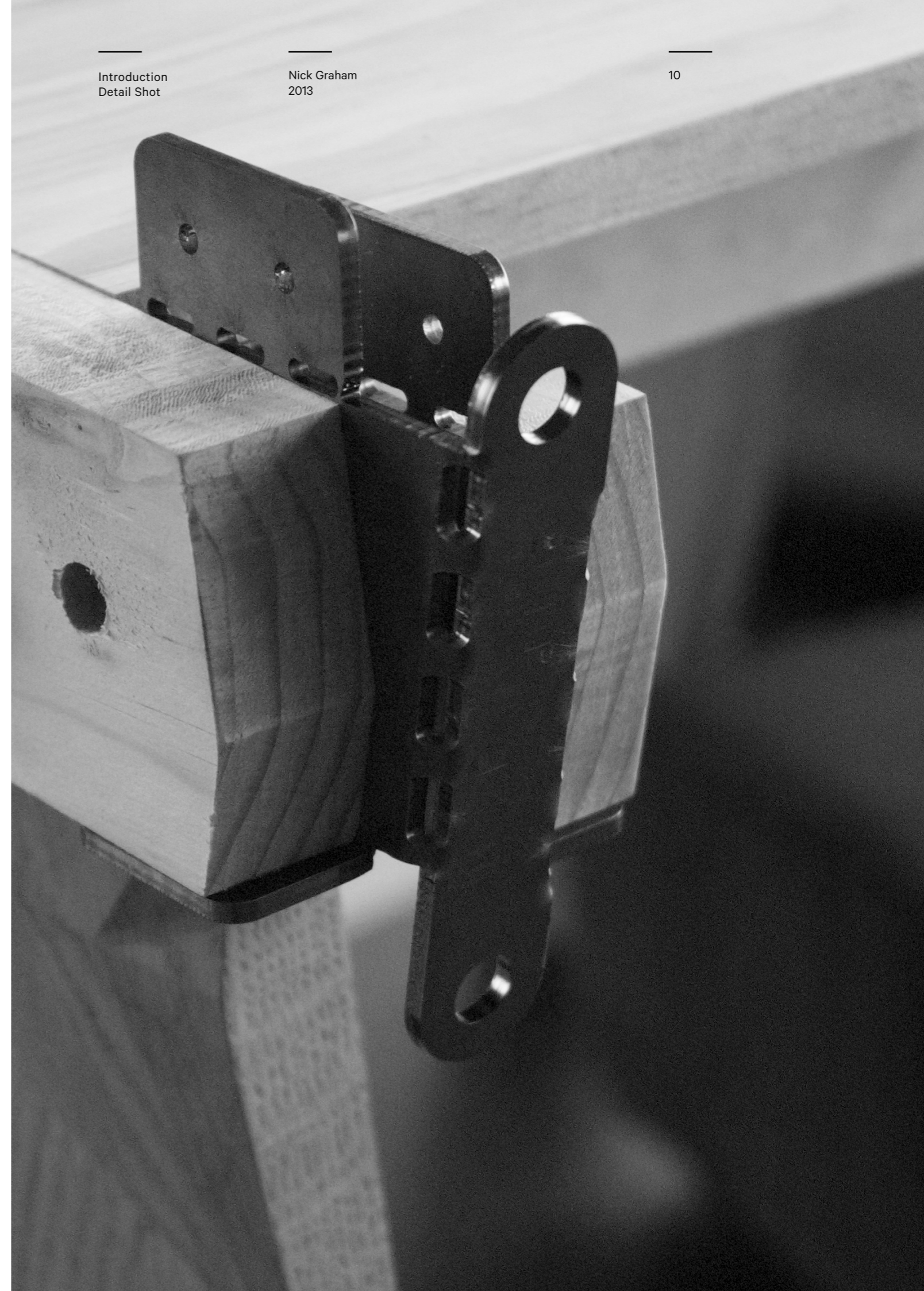

Process.

Technology Experimentation.

The tools and culture surrounding Open Design help to facilitate experimentation and collaboration. Previously people manipulated digital bits, whereas now they are playing with atoms when fabricating physical objects. This has led to predictions of a new industrial revolution, led by start-ups, forward-thinking design studios and “amateur” makers, who now have access to similar tools-to-factory production.

The digital tools employed in current Open Design processes are familiar to tinkerers, hackers and designers; we are used to these technologies and the hassles they can bring. Had I been solely a user/consumer approaching this research I question whether I would have spent as long using digital fabrication processes in some of my exploratory designs that follow.

As Ronen Kadushin says “early adapters are more into making for the sake of making”. Viewing the outcomes of early consumer digital fabrication I have to agree with Kadushin. Sure, there is the exceptionally innovative use of the technology by some; many however, produce objects that are only made because people have the ability, giving no consideration to the products life beyond creation.

As an Industrial Designer, I observe the user experience of digital fabrication processes that so many have claimed will become mainstream and cannot help but think that the technology currently puts so many

constraints on who can actually partake. If any amateur cannot download the files they require to produce an object they are left with the option of computer-aided design (CAD). The once CEO of Desktop Factory Cathy Lewis even says, “today you need to be an expert CAD user to create digital content, or you need a fancy scanner to capture 3D geometry of an object you want to print,” (as cited by Mitchell, 2011). CAD programs such as Tinkercad and 123D are starting to make CAD modeling accessible and user-friendly in relation to professional CAD software, but this is still a potential struggle to the uninitiated nonetheless.

The high skill level required to use current consumer digital fabrication technology was also emphasized while I worked on *Whisper Down the Lane*. Developed by Bronwyn Holloway-Smith, *Whisper Down The Lane* sat along side the exhibition *The Obstinate Object: Contemporary New Zealand Sculpture at the City Gallery Wellington, New Zealand*. During the exhibition a series of digital models and 3D prints were created of works in *The Obstinate Object*.

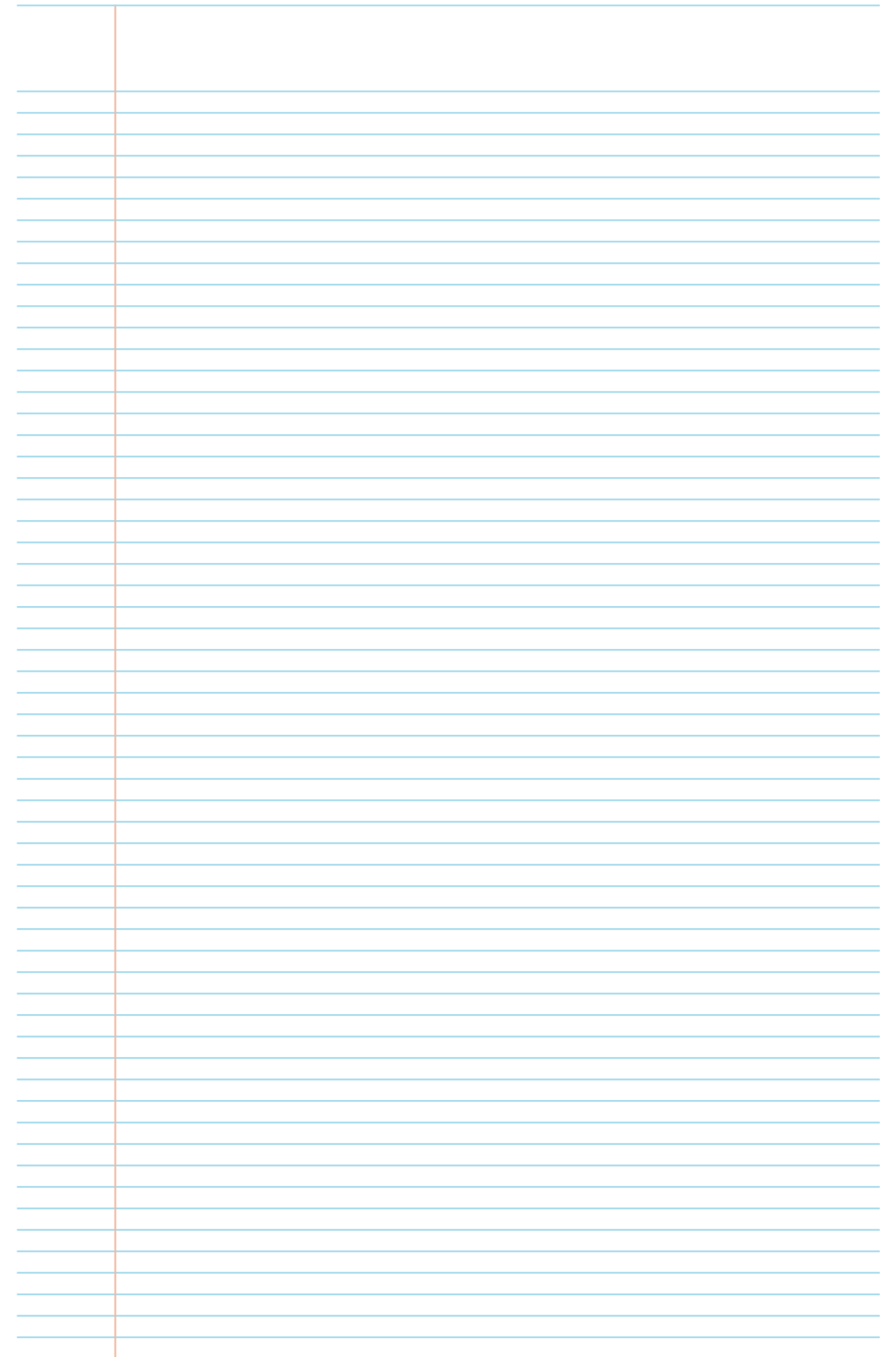



Figure 5: Cmd prompt window required to operate Kintect 3D scanner.

While trying to replicate the objects, using a combination of Kinect scanning, CAD software, photometric scanning and numerous software packages it became clear that there is no one tool or piece of software through which you can approach the entire exercise. It is now about having a selection of tools that use the same open standard file format, and are able to accomplish specific tasks. What is misleadingly portrayed as a simple, highly accessible process (Figure 8) is actually still rather complex.

Increasing education and exposure to design dialogue is important, not in the way of going to a school to learn, but through online forums and spaces such as FabLab's or Makerspaces - it is here that those wanting to learn can set an independent curriculum, collaborate with people that have the knowledge and will ultimately disseminate it to others. It will be this kind of collaboration that will push digital fabrication technology past people making for the sake of making and introduce it to those who are able to apply it in innovative ways to suit their needs.



Figure 6: Whisper Down the Lane. Lance Cash. 2012



Figure 7: Marc Newson: Felt Chair constructed with 123D Make files.



Figure 8: The 3D Print Process. 3dprintuk. 2013

Sedia Mutant.

<http://www.thingiverse.com/thing:24782>

Thomas Lommée (2011) suggests there is a need to change the “myth of creating “something new”, something that “hasn’t been done before”, and to replace it by a willingness to dissolve into bigger projects that just make common sense.” Lommée believes that this will “severely damage the romantic ideal of the “designer-creator” and shift it towards the “designer-collaborator”. I agree with Lommée’s belief that as designers we don’t need to produce “something new”. I do feel though, that as designers we do need to put our signature on what we produce, even when shifting towards the designer-collaborator model of working. It is a way of allowing people to recognize the origins of a work and acknowledge the vision of the author.

The *Sedia Mutant*, a chair derived from the work of Enzo Mari was my initial project on my Open Design research pathway and was instrumental in my understanding of the designer-collaborator model. The primary objective for the project was that a derivative of a proprietary design icon be created to witness how the design culture would respond. This work was to be conducted within an academic institution; derivatives had the potential to be viewed as plagiarism, therefore permission from the icons copyright holder was required.

At the time I viewed this as a set back but as Lawrence Lessig (2008, p.xiv) states; “copyright is, in my view at least, critically important to a healthy culture. Properly balanced, it is essential to inspiring certain forms of creativity. Without it, we would have a much poorer

culture.” The *Sedia Mutant* project exemplified this view that copyright can drive innovation. It was the requirement to seek copyright approval that pushed the project to look for non-proprietary design icons. I began to look at *Autoprogettazione* as a base on which to develop my ideas on derivatives.

In 1974 Enzo Mari released *Autoprogettazione*, a project for making easy-to-assemble furniture using elements that anyone could source, such as rough wooden boards and nails. Mari used it as a way to encourage people to look at the present day production with a critical eye. *Autoprogettazione* was open to anyone; in his own words Mari says, “Anyone, apart from factories and traders, can use these designs to make them by themselves.” (Mari, 2012)

Taking inspiration from my previous work and the work of others in the public domain, I took Mari’s *1123xQ Sedia* chair as the parent design and began to generate a range of derivative chairs that were different but used elements of the original *Sedia 1123xQ* chair DNA.

In a similar approach at DMY Berlin, eight students presented copies of famous works by top designers. *Copy and Authorship* included derivatives of designers’ works such as Jurgen Bey, Maarten Baas and Ettore Sottsass. The students reproduced each work exactly before going on to make alterations and additions to the design. “What we are doing is the exact same way design was taught a century ago,” says Verweij. “Learn from your master, learn by doing. Show your talent by copying” (Verweij, 2011).

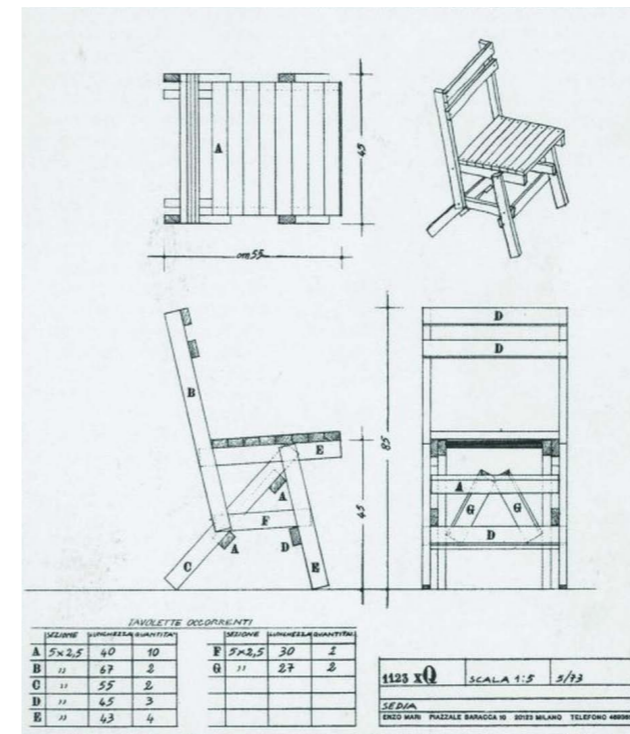

Figure 9:
Autoprogettazione Sedia
Chair by Enzo Mari. Domus.
2012

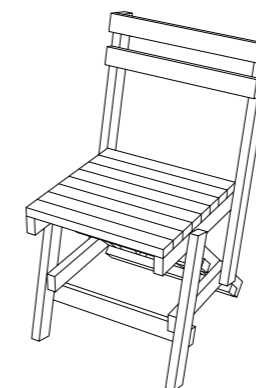

Figure 10: Sedia Chair.

It is this process of learning while doing that highlights some advantages of being a design collaborator and producing derivatives. When a design is made available in the public domain it allows people to participate and educate themselves. If there is clear and open documentation, we can take inspiration and apply it to a completely different piece of work, thereby enriching our own practice and designs. As designers we can quickly forget that “No artist works in a vacuum. Every artist reflects—consciously or not—on what has come before and what is happening parallel to his or her practice” (Lessig, 2008, p.8). Drawing inspiration from what is around us is inevitable, made even more so by the Internet and the countless creative communities thriving within it. Instead of being opposed to such a large and growing open knowledge base, we need to join it, for our own benefit and for those who may benefit from open access to our work.

Development of Derivatives.

The Sedia derivatives were inspired by my previous engagement with 123D Make and the Hackchair by Ronen Kadushin. The derivatives were going to utilise laser cut sheet metal so that new elements could be folded by hand and attached to the original Sedia chair. Looking back at the way the derivatives were conceived, they were brought to fruition through the classic Industrial Designer's process; via sketch, prototype and CAD.

I had originally tried to develop the sheet metal using CAD in the first attempt but subsequently discovered that the process was far too structured and didn't allow for any 'on-the-fly' development. I resorted to full-scale mock-ups using cardboard and tape. It was at this point I began to realize that my design training would not become as immaterial to the Open Design process as I had first thought.

Although the method above is second nature to most Industrial Designers, it is interesting to think about how an amateur may have attempted to advance the design of a derivative. Would using cardboard have crossed their mind? Or would they have just used CAD and settled on the first form they managed to produce?

By exploring these derivatives, I learnt that hybrid designs have their place in an innovative open practice. Yes, the idea of an inspirational source can be abused, but by acknowledging such inspiration and using it in a derivative it can help to create a deeper understanding of the original work and appreciate all parts in the whole. Breitz (as cited in Lessig, 2008) gives a prime example;

In African and other oral cultures, this is how culture has traditionally functioned. In the absence of written culture, stories and histories were shared communally between performers and their audiences, giving rise to version after version, each new version surpassing the last as it incorporated the contributions and feedback of the audience, each new version layered with new details and twists as it was inflected through the collective. This was never thought of as copying or stealing or intellectual-property theft but accepted as the natural way in which culture evolves and develops and moves forward. As each new layer of interpretation was painted onto the story or the song, it was enriched rather than depleted by those layers (p.7).

As designers, we need to recognize that when our work is derived, it augments the design's meaning. It may not be in a way that we would ourselves have done it, but it is nonetheless enriched in the eyes of the derivative author.

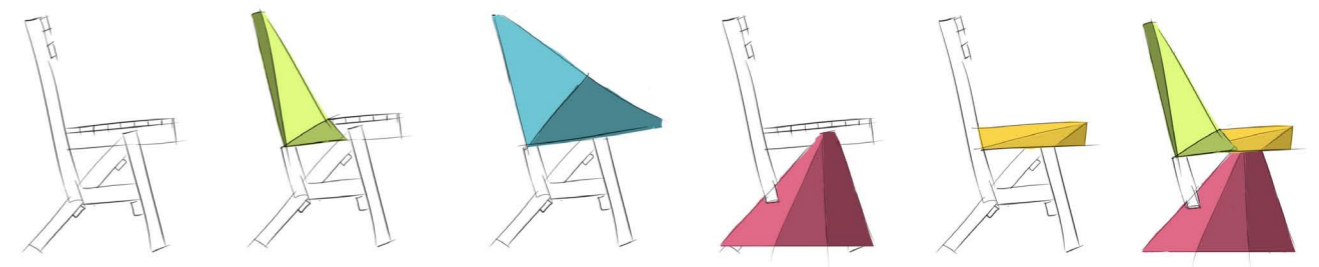

Figure 11: Sedia Derivatives.

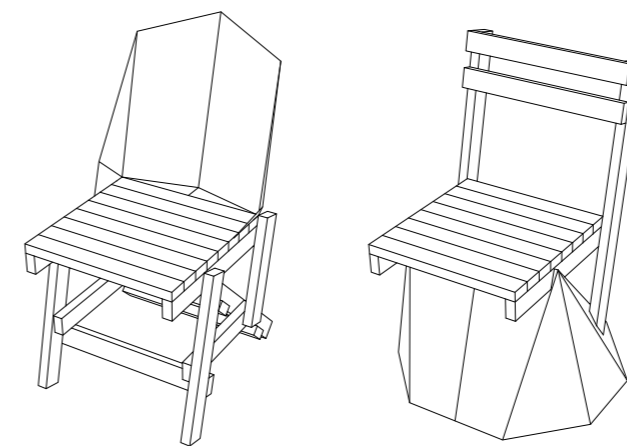

Figure 12: 3D Sedia Derivatives.



Figure 13: Cardboard Prototyping.

Layer Stool.

<http://www.thingiverse.com/thing:32036>

Jens Dyvik is a Norwegian designer that is exploring digital fabrication and parametric design software. Full disclosure, the work was created on propriety software. It was not aimed at critiquing the software though. The *Layer Stool* gave me an insight into parametric modeling and creating organic surfaces using digital fabrication. It also drove home the issues that can arise from designing only on CAD, and therefore highlighted the need for simplified user interfaces. However these were all secondary results. The main reason for producing this stool was to see how Jens, the 'original' author of the design, responded to my derivative of his work and also to trace the interaction that occurred between us both.

Up until now, I have been the designer submitting my work into the Open Design community (with varying degrees of external interaction with the works). Fabricating this stool gave me the opportunity to be located somewhere entirely different upon the design interaction loop. I am still an author, but one for a derivative work.

While designing the stool Jens was also attending the Wellington Fablab. This meant that when I altered the original design from a chair to a stool and the software removed the legs for a reason unbeknown to me. Jens was able to assist in altering the file to enable the software to once again include the legs. I would have spent many hours trying to discover why the legs had disappeared in the file I had changed. It took Jens all of 2 minutes to tell me what was wrong and rework the file. As a result, Jens left the Fablab with a file that could

not only build chairs, but stools as well. I was left with a better understanding of the software and the files for fabricating a stool.

I had told Jens that I had made a derivative and left it at that. Jens was very keen to see photos of the stool. I sent a few images I had taken while building it. To my surprise I received an email from Object Magazine asking if they could use some images of the derivative stool for an article they were running on Jens Dyvik's design. Participating with the project also gave me contacts with others who have derived Jens's stool around the world. In comparing Open Design interaction to my experience of Industrial Design interaction, I have noticed the following:

'End User' interaction in Industrial Design is more about interacting with the features of an object, whereas in Open Design, the interaction is with the processes required to make an object.

The author/designer is removed from direct feedback in the Industrial Design interaction. Open Design interaction allows both the original designer/author and the derivative designer to not only give feedback to one another but also help progress their own work through collaboration; in essence, enabling each other.

This process emphasized how much easier it is to facilitate an open standard in a physical space than it is on the Internet. When creating open standards or frameworks for online use we need to think of whom the audience is, just as we would when designing a product. Will the semantics be understood and if the collaborators are unable to achieve what they set out to while deriving your work, what systems are in place to assist them?

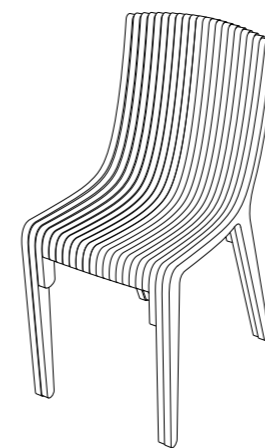

Figure 14: Layer Chair.



Figure 15: The Layer Chair Amsterdam edition. Jens Dyvik

Referencing Design DNA

With design starting to disseminate globally, alongside the digital fabrication tools that enable more people to participate, there is an abundance of new culture being created and “creative projects are starting to have a life of their own” (Kosner, 2013). Referencing Design DNA looks at ways to credit the authors of past designs and future derivatives while acknowledging those who participated in a works development. The concept of acknowledgment is not a new one as Lessig (2008) points out;

We all expect that we can quote, or incorporate, other people’s words into what we write or say. And so we do quote, or incorporate.... Of course, citation is required. But the cite is always sufficient payment. And no one who writes for a living actually believes that any permission beyond that simple payment should ever be required (p.78).

So where is this belief for physical designs? Up until recently this concept has not been incorporated into the design of objects. Thingiverse.com is a social network of people creating “digital designs for real, physical objects” (MakerBot, 2013). They have started to take the concept onboard, and applied it to referencing open designs online. Initially there were shortcomings when using Thingiverse as a way to reference designs as “Thingiverse’s framework assumes that a derivative work only has one ancestor, which is not always accurate. And some times the ancestor is off site” (Palecek, 2012). This was partially resolved on the 9th of January 2012 when Thingiverse updated their site allowing multiple ancestors for any work. Nonetheless for a site based on sharing, it forgets that not everything is born within Thingiverse, and the only option to reference inspiration from off site is to add the web address, resulting in

broken links back to the original author or design. Andrew Keen (2008) claims, “The world is awash with drivels because it is so easy to propagate ideas on the Internet...A healthy society needs gatekeepers...only then can we ensure quality.” Referencing offers an alternative to this. Referencing can’t stop the “drivel” but it can keep track of whose derivatives are reputable, allowing certain authors to amass a justifiable following. Thingiverse began offering this feature on the 7th of November 2012 and now lets community members follow other users they feel produce quality or interesting designs, offering up the power and responsibility of “gatekeeper” to the people.

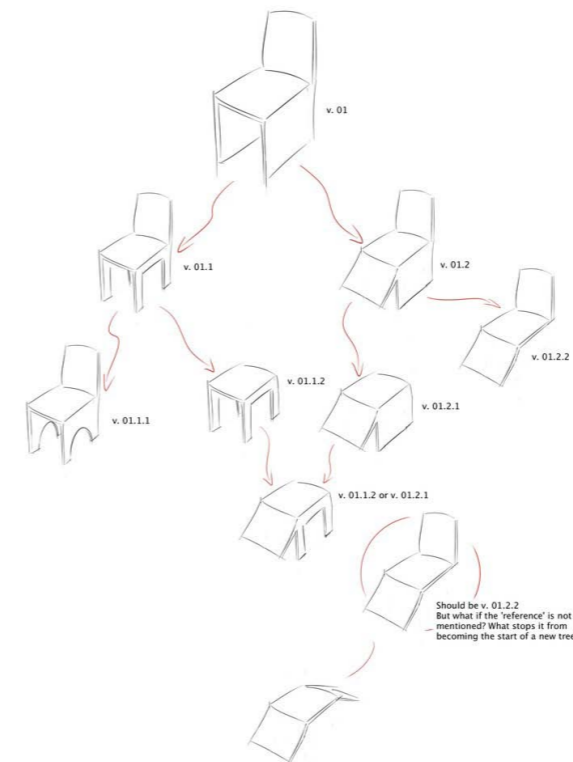

Figure 16: Designs with Derivatives.

We have to move towards a system where a person’s contribution to a design can be measured and that person can be given proper credit for their efforts. This means that the designer has to let go of the feeling that ‘it was my idea’ Rulkens (as cited in Abel, 2011, p.238)

What Thingiverse doesn’t allow is a person’s contribution to a design to be measured, quantitatively or qualitatively. It can be hard to tell just how influential someone’s additions are to a project. Google’s tool *Source* allows the visualization of Open Source communities. It enables contributors to see the changes that have been made and any additions to different nodes.

Process
Detail shot

Nick Graham
2013

26



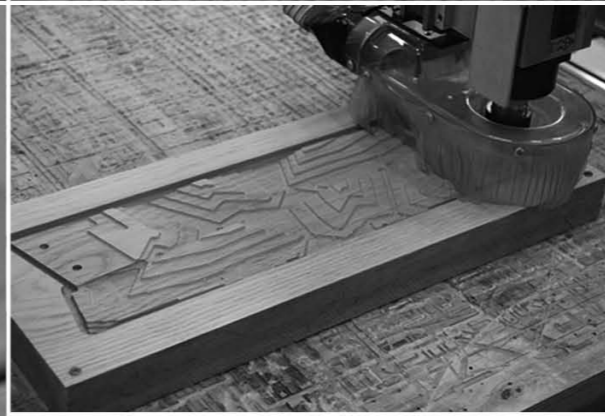
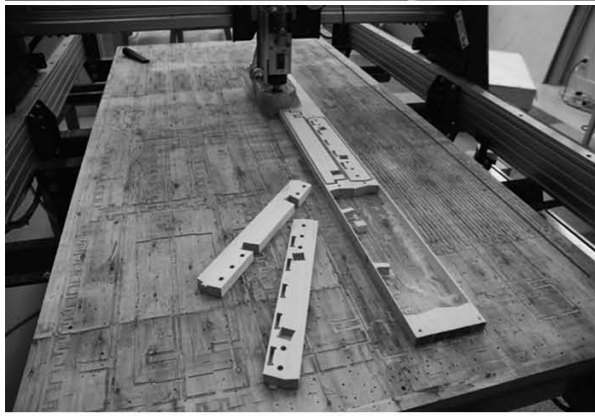
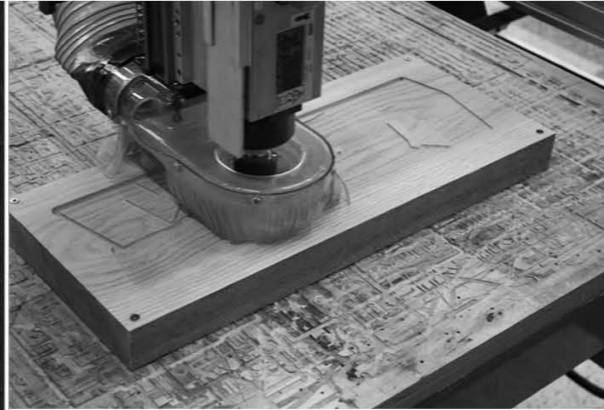

EC Chair

(<http://www.thingiverse.com/thing:38553>)

The *EC Chair* was a design-led research project that explored the concept of collaboration associated with open source digital fabrication technologies and communication networks in the context of furniture design. It was achieved by developing the idea of "The Exquisite Corpse" into a global digital design event where the physical outcomes of the design exercise illustrate the new frontiers of design.

Exquisite Corpse is the old parlor game, played by several people, each of whom would write a phrase on a sheet of paper, fold the paper to conceal part of it, and pass it on to the next player for their contribution. The *EC Chair* digitizes the game and replaces phrases with 3D designs.

The final result was a collaborative chair incorporating the work from designers situated around the world. The final files were then published online and were produced in the Wellington FabLab using digital fabrication techniques to the specifications set by each participating designer.

The three participating designers were:

Jens Dyvik - Norway

Ronen Kadushin - Israel

Nick Graham - New Zealand

The rules were:

Each designer will be given part of the chair to design. **The designer will** only be able to see a 20mm section of the previous chair part. **They may design their** section of the chair as they please. **The final part must be** producible with digital fabrication techniques. **The designer can use** any material they see fit. **The design should be** at 1:1 scale. **A description will be required** to accompany the design. (This may include, but is not limited to: inspiration, build instructions, material specifications...) **A digital file** that can be emailed or transferred via the Internet. **Time spent** on the design should be no more than 3 hours.

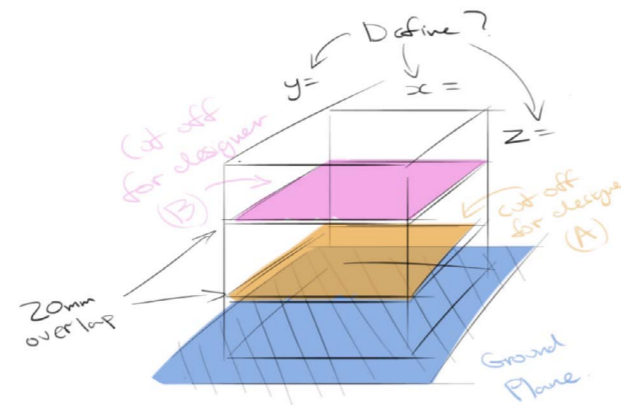

After initiating the game's first stage, without thinking, I realised that I'd subconsciously designed the next section of the chair in my head. I had hypothesized what the outcome would be. The joints were going to be highly detailed and it would be constructed using a limited palette of materials. Although I had high hopes for its aesthetic, I didn't think that it would ever be functional. This process went against what I had learnt from the church of Industrial Design. A product couldn't/wouldn't be functional if those contributing to it didn't have a holistic view of the entire design.

Figure 19: I considered putting a limit on the x, y, z dimensions of each section, just as the paper does in the Exquisite Corpse game.

These are the resulting contributions, with the description supplied by the designer, in order of creation.

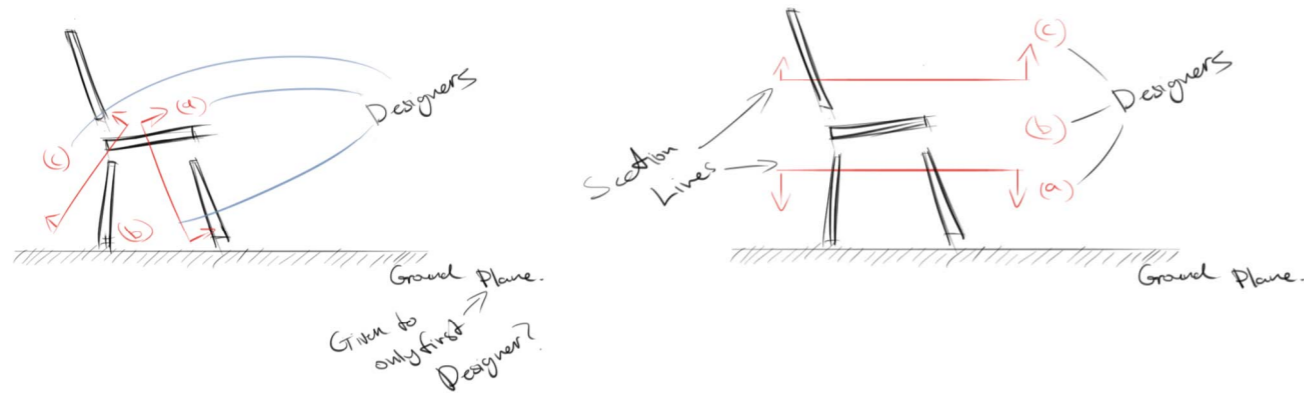

Figure 18: Sketches of how the chair may be split. I decided upon the common lines that are used in the Exquisite Corpse game.

Nick Graham - Inspired by the aesthetic of Phil Cuttance and his facature project. I wanted to machine the legs in a style that suggested they were digitally fabricated. They are also a reference to the way in which CAD files are output as polygons. Machined from Oak.

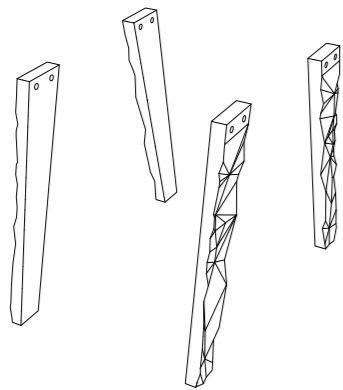

Figure 20: Facet Leg

Jens Dyvik - I designed the seat in a café in San Francisco yesterday. Here are the part files for the seat. Sorry for the delay. Let me know if anything is unclear. Got a bit carried away, so I spent a total 3 hours modeling. The CNC milled parts should be made from massive wood planks 25mm and 12mm thick, minimum width is 80mm and 100mm (see Rhino file for reference). The dog bones are designed for a 6mm milling bit. The engraved text for the seat planks should be milled with a 6mm bit and 3mm deep. The depths of the different pockets are specified in the layer names. You should be able to import the dxf directly to Partworks with color-coded named layers. Remember to join open vectors once you have imported. The laser cut parts should be made from 3mm thick pink, purple or similar acrylic. To assemble the seat to the legs you will need 4x 90mm long and 10mm diameter bolts, plus nuts. There is 0mm tolerance on all the parts. I recommend a sharp single or double flute up cut-milling bit.

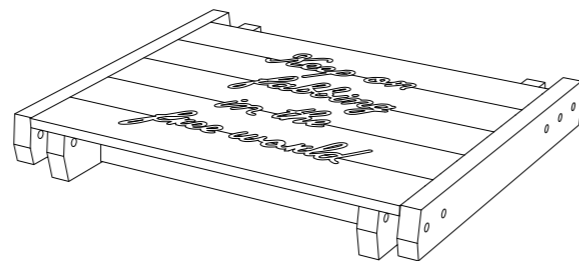

Figure 21: Jens Seat Pan

Ronen Kadushin - See attached rhino file. 18mm Ply. The back design was inspired from this duo: The Evens – King of Kings.

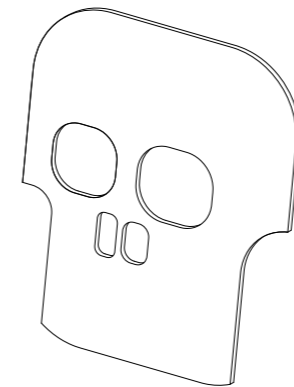

Figure 22: Ronen Seat Back

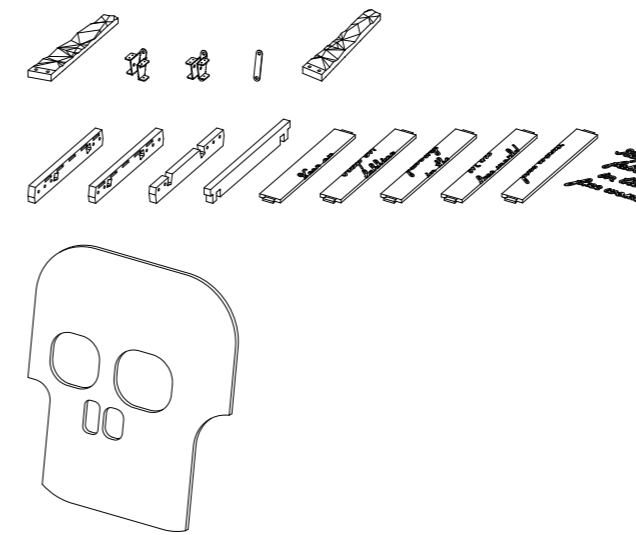

Figure 23: EC Chair Parts

When I received the files back from both designers my assumptions were proven wrong. I had an anxious tension with the chair's appearance. It was not what I had expected from either designer, and especially not what I had in mind to complement my legs. While producing the chair though, I began to move past its aesthetics and consider how this could catalyse a new system for me to design within.

In theory, because the past contribution could not be seen, the next participant should not have been influenced by what had already been designed. However this was untrue, as although I did not know it, I became a large driver for the overall appearance of the chair. Being able to position the legs where I desired, gave me the ability to direct where the seat went, how high it was off the ground, how wide it was and what joints to use, which seemed to have influenced Jens in his choice of join.

This process of design started to reveal an interesting aesthetic for a chair produced entirely by designers. There were no unifying features; one could clearly identify the individual sections of the chair without knowing what they were. Reflecting on the process though this is what it should be like. Each designer has drawn inspiration from different areas; with no tight framework to hem them in they have been able to express themselves as they wish.

This process showed how even designers may interpret the rules in completely different ways. Although Exquisite Corpse is a linear game, there are elements in this chair that overlap. The back of the chair wouldn't be attached had I not created a bracket after seeing the chair in its entirety. I realized that I became a moderator of the process.

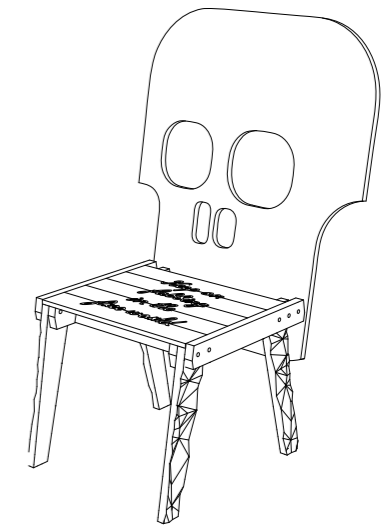

Figure 24: Final EC Chair

Nicholas G. Carr in (The Ignorance of Crowds) views the open source model of production not as democratic as it is often made out to be. He uses Linux as an example, stating that:

Linux has been successful not just because so many people have been involved, but because the crowd's work has been filtered through a central authority... Linus Torvalds has gathered a hierarchy of talented software programmers around him to help manage the crowd and its contributions. It's not a stretch to say that the Linux bureaucracy forms a cathedral that coordinates the work of the bazaar and molds it into a unified product (p.3).

Although originally written opposing the open source production method, as designers we can take Carr's statement and work with the new opportunities it offers us. Designers can become shepherds, not controlling where the herd goes, but rather keeping them safe. This could be accomplished by offering a framework or a rule that anyone could build from; it would ensure the resulting elements would work with each other; "this will require a different mindset from all stakeholders of the design process. In order to think 'within the box', in order to accept and embrace the new opportunities that emerge out of common restrictions, (Lommée, 2011)

An open invitation to design

(<http://www.thingiverse.com/thing:34077>)

Derived from the *EC Chair* and Lommée's *Open Structures*, *An Open Invitation to Design* is just that, an open invite to anyone wanting to collaborate with creating an open chair. The project was subsequently uploaded onto Thingiverse. This was the ideal site to situate this work in, as mentioned previously, it provides a basic framework for tracking derivative work from project to project. *An Open Invitation to Design* looked at the issue of open collaboration using an open standard.

By utilizing the Internet, An Open Invitation to Design takes advantage of the ability to share digital files. Unlike conventional collaboration there is no need to be in the same room as the other participants. This obviously makes collaboration easier in regards to collaborating globally but raised some issues when having to inform participants on how to contribute. It allowed anyone to be involved, from tinkerers, designers, hackers and students. There was no criterion people had to meet, just a willingness to participate. *An Open Invitation to Design* was first published to Thingiverse on the 11/11/2012 and has remained online since. This is how the system was first described;

The chair is split into 3 parts - legs, seat and backrest. I imagine at first there will be a range of odd chair parts, hopefully over time people will take these parts and build from them with the goal of having a finished chair with 3 parts designed by 3 different people.



Figure 25: The OS Grid.
Thomas Lommée.
2011

Every part designed only **needs to meet two criteria.**

One - it must be producible on one of the machines listed: Shopbot CNC, Laser Cutter (Sheet metal) 3D printer, PLA and ABS, bed size of 140mm L x 140mm W x 135mm H, Laser Cutter (Sheet acrylic.)

Two - it needs to incorporate the standardized join that can be found in the attached files. This is to enable parts to be built upon with relative ease. The join comes in 3 variations. All use 10mm diameter hole of any depth and are surrounded by a required flat section (Fig 26).

When you upload your part please feel free to leave build instructions and what inspired you. If you are building off someone else's part please let me know what part it is. As long as your part meets these requirements you are free to make what you want and I will do my best to produce it. This all may seem a little confusing, so please ask if you have any questions.

Looking forward to seeing what you create.
A big thank you in advance.

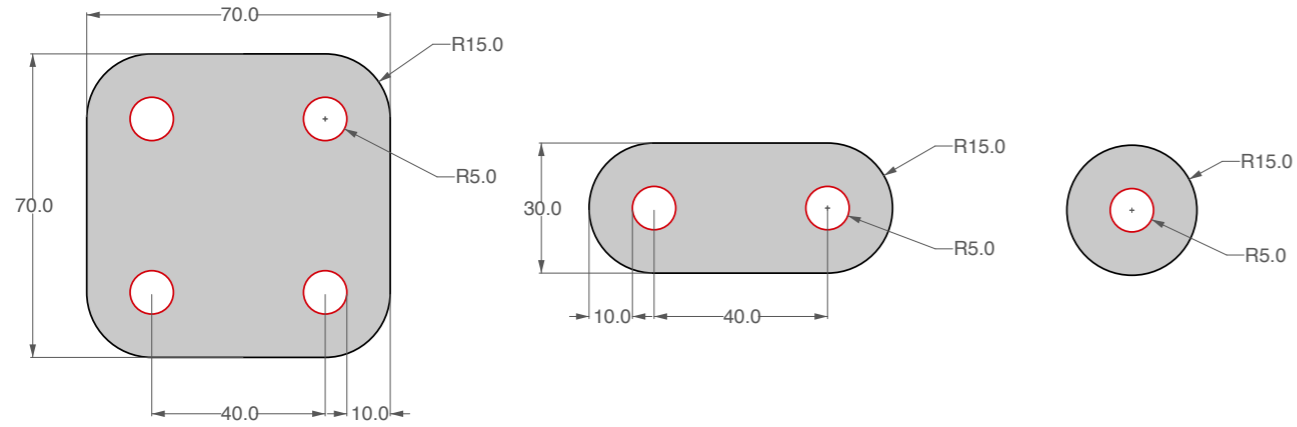

Figure 26: Join options uploaded to Thingiverse.

At last count the join and its derivatives had over one hundred downloads. As a result when giving the outcomes of this work an author there needs to be an understanding that “participatory design has changed the role of the designer: from an author of finished products, like books or furniture, into a developer of frameworks or structures of ‘open works” (Herst, 2011, p.220). Therefore I am author of this system and make no claim to the authorship of the outcomes produced therein.

Lego is the perfect example of how this system can work. 7,000 different Lego elements, can work with at least one other. “The concept of introducing a set of open standards is nothing new. Whenever there has been a need for sharing, open standards have always emerged as a means to generate more flexible and resilient models of exchange” (Lommée, 2011).

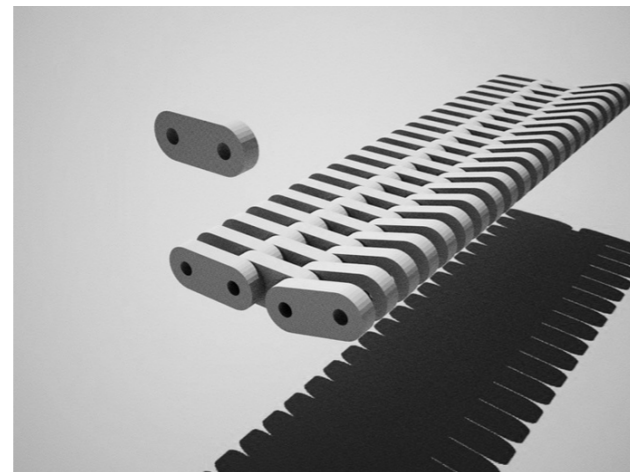

Figure 27: Knucklebuster.
fractaldesign.
2012

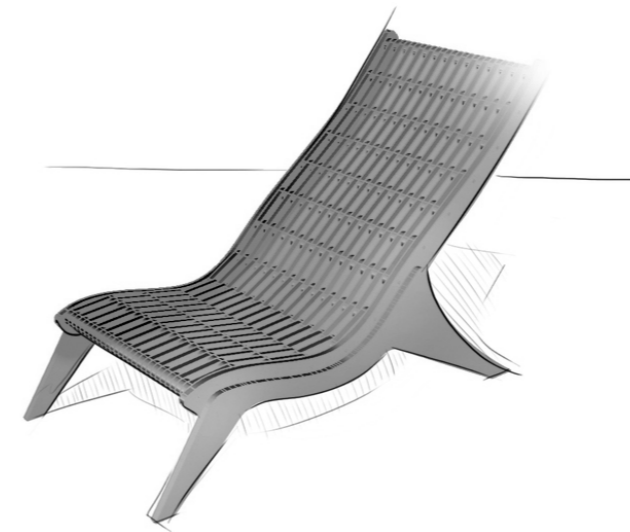

Figure 28: Knucklebuster
Lounger. E_T.
2012



Figure 29:
KnuckleSeat. E_T.
2012

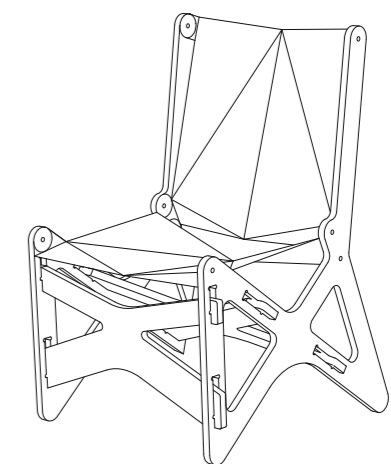

Figure 30: No Knuckle Seat,
Nick Graham.
2013

In theory, collaboration within *An Open Invitation to Design* was to happen easily and extensively. There was a standardized rule that governed how each design would join to the next (Figure: 26). This was kept as simple as possible in an attempt to not overcomplicate the process of incorporating the join into an element. A digital file was also supplied to ensure the join was always the same. Participants had the choice of designing one of three parts. In practice however, issues arose with how participants were using the file. Some thought it was a metal plate that had to be inserted into their design; others were unsure if they should build onto a part already designed or if they should start something new. Some took what others had done and turned that concept into a complete chair (Figure: 28, 29). What was especially notable, and the opposite to what I had hypothesized, was that participants were not working with each other's elements. Everyone was designing from the beginning and this resulted in elements left as incomplete chairs. Why did most want to start afresh? Is it because "No designer of our generation wants to be a pixel; we all want to be the full color image." (Lomm e, 2011)

So why did this happen? What caused the differences between what was expected and the actual practice? After reflecting on this and talking to participants it became clear that it was the documentation. I realized that unlike the *EC Chair* where the designers required little instruction or were able to understand what was being asked due to their knowledge of design, participants in *An Open Invitation to Design* required far more guidance. I had fallen into the trap of assumption. Having been the author of the system I knew how I wanted it to work and had assumed others would too. This meant I had simplified the documentation. In an

attempt to make *An Open Invitation to Design* more open though, I left the instructional documentation bare, hoping that this would give people the freedom to do what they like. So much so, that you needed prior knowledge to collaborate with the system. This may have been the reason behind the varying levels of collaboration.

So in order to generate a system that encourages collaboration, the author of that system needs to produce clear and transparent documentation. It cannot be focused at the expertise level of the author either. It needs to be legible for those with no knowledge of design and production. What good is an open design if it is already self-selecting who can take part just from its documentation? It is crucial to the successes of the collaboration that participants can understand what is being asked of them. Successful instructional documentation will encourage a work to be derived no matter how finely tuned the specifications are.

Open Design will certainly confront us with challenging questions about the current way we practice design and it will also impose some restrictions on aspects of our work. However, any designer knows that a brief without restrictions is almost always the most difficult to work with.

In addition, these open models also raise questions regarding... **how do we balance openness and protection, freedom and restriction?** Since every standard by definition imposes a restriction, it limits our choices, obstructs our freedom to design and shape, and it disrupts our independent position as designers (Lomm e, 2011).

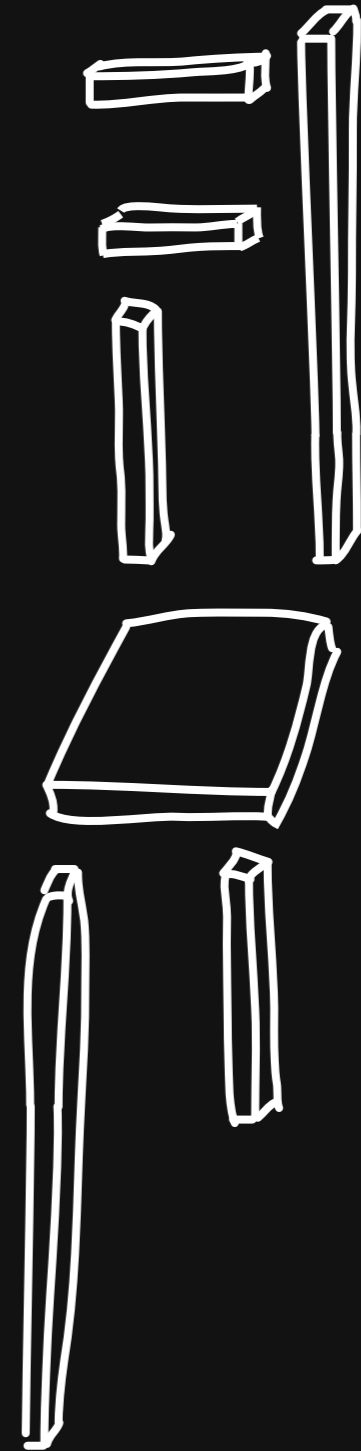
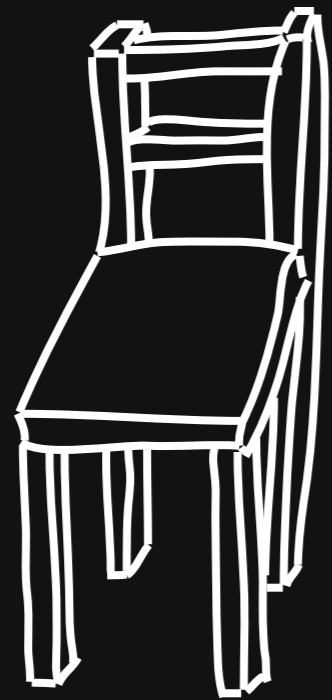

Conclusion

Open Design will soon provide everyone with the option to be authors of objects, not just blogs and Tumblrs. Designers will be placed into the category of authors, but authors may not necessarily be classed as designers. The label of designer suggests a level of critical thinking, a skill that will become even more valuable than it already is when employing an Open Design system.

The idea that there is one individual author for a work will become far less common. When describing the source of a work we will now see more and more objects with multiple authors credited. Open dialogue and the transferral of individual knowledge, either online or in a Fablab will improve the overall quality of this work.

Successful Open Design should invite people to not just passively consume the design, but rather it should offer up a draft, and give people the option to derive it. This idea is going to force designers to “start listening better in a world where the designer doesn’t make the design decisions, but rather facilitates the process of designing decisions” (Rulkens, as cited in Abel, 2011). This new movement will require a new kind of designer, one who recognises that we are not “promoting a “free economy”...” but one where those who participate are profiting sometimes monetarily and other times by using their experience to further their careers or expand their network” (Tapscott, and Williams, 2006, p.11).

As designers we have to understand we are now living in an era where people will share our work whether we give them permission or not. Therefore the outcomes that we produce will become far less important compared to the processes used to create them. We need to design

systems that offer individuals ways of interacting with one another in order to produce their own outcomes. Along the way, we must still ensure that we apply our formal training when and where applicable to create truly open systems and not just systems of mass customization.

The designer’s role in a practice of Open Design is not just to disseminate knowledge to others. It is also to learn from how others interact with their systems, as was the case with the *Layer Stool*. These open systems will take time to develop. It will be a case of designers continually reflecting on their meta designs and adjusting them to the needs of those collaborating within them.

My old romantic view of the Industrial Designer would have struggled to accept the tenets of Open Design. I have come to learn though, that if new generations can be given access to tools and systems that allow them the ability to derive and produce designs, there is no doubt that this will aid in educating people that design is more than the application of frills, but is in fact something that can and should be used to enrich our private and collective spaces. Who knows what the next derivative will be, but the more that people are granted access to a basic Open Design opportunity, then the greater our hit-rate will be for innovative mutations that may benefit us all.





Reference List

Aviv, Z. M. (2011). Learning by Doing, In: Van Abel, B, (et al), Open Design Now: Why Design Cannot Remain Exclusive, Netherlands: BIS Publishers.

Benkler, Y. (2006). The Wealth of Networks: How Social Production Transforms Markets And Freedom. Yale University Press.

Carr, N. (2007). The Ignorance of Crowds: Strategy & Bussiness. Issue 47. Booz & Company Inc.

Dexter, M. Jackson, C. (2012). Making Space: The future places, tools and technologies for open design. Paper presented at ICDH 2012 - Design Frontiers: territories, concepts, technologies.

Godwin, S. (2009). Seth Godin: How to get your ideas to spread. (Video file) Retrieved from http://www.ted.com/talks/seth_godin_on_sliced_bread.html

Herst, D. (2011). Form Follows User, In: Van Abel, B, (et al), Open Design Now: Why Design Cannot Remain Exclusive, Netherlands: BIS Publishers.

Junte, J. (2012). Open Design is not a clear-cut ideology, but it has different manifestations. Retrieved from http://waag.org/sites/waag/files/public/Publicaties/Open_Design_Jeroen_Junte.pdf

Katz, A. (2011). Authors and Owners, In: Van Abel, B, (et al), Open Design Now: Why Design Cannot Remain Exclusive, Netherlands: BIS Publishers.

Keen, A. (2008). The Cult of the Amateur: How blogs, MySpace, YouTube, and the rest of today's user-generated media are destroying our economy, our culture, and our values. 1745 Broadway, New York: Crown Publishing Group.

Kelion, L. (2012). CES 2012: 3D printer makers' rival visions of future. Retrieved from <http://www.bbc.co.uk/news/technology-16503443>

Kosner, A. (2013). How Open Source Software Blooms: Gource Version Control Visualizations From Google. Retrieved from http://www.forbes.com/sites/anthonykosner/2013/01/01/how-open-source-software-blooms-gource-version-control-visualizations-from-google/?utm_campaign=techtwitter&utm_source=twitter&utm_medium=social

Lessig, L. (2009). Remix: Making Art and Commerce Thrive in the Hybrid Economy. Penguin Books.

Lommée, T. (2011). Open Source Design 05: The Esperanto of objects. Retrieved from <http://www.domusweb.it/en/design/open-source-design-05-the-esperanto-of-objects/>

MakerBot Industries. (2013). Thingiverse. Retrieved from <http://www.thingiverse.com/>

Mari, E. (2002). Autoprogettazione: Ediz. italiana e inglese. Corraini.

Mitchell, R. (2011). 3D Printers: Almost Mainstream. Retrieved from http://www.pcworld.com/article/246773/3d_printers_almost_mainstream.html#tk_nl_dnx_h_crawl

Mul, J. (2011). Redesigning Design, In: Van Abel, B, (et al), Open Design Now: Why Design Cannot Remain Exclusive, Netherlands: BIS Publishers.

Palecek, J. (2012). CC and the 3D Printing Community. Retrieved from <http://creativecommons.org/weblog/entry/30605>

Sanders, E. Stappers, P. (2008). Co-creation and the new landscapes of design, Retrieved from http://www.maketools.com/articles-papers/CoCreation_Sanders_Stappers_08_preprint.pdf

Stallman, R. (1999) The GNU Operating System and the Free Software Movement, In: DiBona, C, Ockman, S, and Stone, M, (1999) Open Sources: Voices from the Open Source Revolution. O'Reilly & Associates.

Tapscott, A, Williams, D. (2006). Wlkinomics. Editorial Paidós.

Vallance, R. (2000). Bazaar Design of Nano and Micro Manufacturing Equipment, Retrived from atwww.engr.uky.edu/psl/omne/download/BazaarDesignOpenMicroAndNanofabricationEquipment.PDF

Van Abel, B. Evers, L. Klaassen, R. & Troxler, P. (2011). Open Design Now: Why Design Cannot Remain Exclusive, Amsterdam: BIS Publishers.

Verweij, L. (2011). Copy and Authorship. Retrieved from <http://www.dezeen.com/2011/06/09/copy-and-authorship-by-lucas-verweij/>

Figure List

Unless otherwise identified all images are the work of Nick Graham and licensed under a Creative Commons Attribution-ShareAlike 3.0 License.

Figure 1. Open Structures. (2012). Closed modular systems. Retrieved from <http://openstructures.net/pages/2>

Figure 2. Open Structures. (2012). Open modular systems. Retrieved from <http://openstructures.net/pages/2>

Figure 3. Nike. (2012). Nike ID customization app. Retrieved from http://store.nike.com/us/en_us/product/lunarglide-4-id-running-shoe/?piid=27912&pbid=442286899#?pbid=442286899

Figure 4. Derived from Open Structures. (2012). Mass customization vs Open Design. Retrieved from <http://openstructures.net/pages/2>

Figure 7. Lance Cash. (2012) Whisper Down the Lane. Retrieved from <http://bronwyn.co.nz/projects/whisper-down-the-lane/>

Figure 8: 3Dprint Uk. (2013). The 3D Print Process. Retrieved from http://www.3dprint-uk.co.uk/3d_printing.html

Figure 9: Domus. (2012). Autoprogettazione Sedia Chair by Enzo Mari. Retrieved from [http://www.domusweb.it/it/upcoming-event/call-for-ideas-autoprogettazione-20-/](http://www.domusweb.it/it/upcoming-event/call-for-ideas-autoprogettazione-20/)

Figure 15: Jens Dyvik. (2012). Jens Dyviks Layer Chair. Retrieved from <http://www.dyvikdesign.com/site/portfolio-jens/the-layer-chair-amsterdam-edition.html>

Figure 17: Gource. (2013). Google's Gource visualization of 3D design software Blender. Retrieved from <http://www.forbes.com/sites/anthonykosner/2013/01/01/how-open-source-software-blooms-gource-version-control-visualizations-from-google/>

Figure 25: Thomas Lommée. (2011). The OS Grid. Retrieved from <http://www.domusweb.it/en/design/open-source-design-05-the-esperanto-of-objects/>

Figure 27: fractaldesign. (2012). Knucklebuster. Retrieved from <http://www.thingiverse.com/thing:35010>

Figure 28: E_T. (2012). Knucklebuster Lounger. Retrieved from <http://www.thingiverse.com/thing:35653>

Figure 29: E_T. (2013). KnuckleSeat. Retrieved from <http://www.thingiverse.com/thing:41296>

Appendix

Ethics:

This project has been evaluated by peer review and judged to be low risk. Consequently, it has not been reviewed by one of the University's Human Ethics Committees. The researcher Nick Graham is responsible for the ethical conduct of this research.

If you have any concerns about the conduct of this research that you wish to raise with someone other than the researcher, please contact Professor John O'Neill, Director (Research Ethics), telephone 06 350 5249, e-mail humanethics@massey.ac.nz.

