

Copyright is owned by the Author of the thesis. Permission is given for a copy to be downloaded by an individual for the purpose of research and private study only. The thesis may not be reproduced elsewhere without the permission of the Author.

**DESIGN OF A WRIST AND OPERATOR INTERFACE
FOR AN AGRICULTURAL MANIPULATOR**

**A thesis presented in partial fulfilment of the requirements for
the degree of**

**Master in Technology
In
Engineering and Automation**

At Massey University, Turitea, Palmerston North, New Zealand.

Adrian Peter Charles Noaro

2000

“I invented the cordless extension cord”

Steven Wright

ACKNOWLEDGEMENTS

Thanks to my supervisor, Dr Ted Smith for his guidance and support during the project.

Thanks to the Foundation for Research in Science and Technology for their generous support with the Graduate Research in Industry Fellowship.

My special thanks goes to Mum & Dad for their support both moral and financial during this project and my years as an undergraduate. I couldn't have got this far without you both.

Thanks to my sister Rebecca who has been a driving force to help me complete this project. Also for insisting on supplying free lunches at her Deli.

Thanks to Shane for his wonderful knowledge of MATLAB and for introducing me to a wonderful game called Quake III. A great game for tension release.

Thanks to Mr Greg Jensen from Pivot Engineering Ltd. for approaching Massey University with a design problem that initiated this project.

SUMMARY

This project is involved with the development of a wrist and control system for an agricultural manipulator called the Hydra Trim. The Hydra Trim is intended for use with regional Councils and private contractors for roadside mowing and hedge trimming.

Background research was conducted. This research established that the hedge trimmers on the market are large, bulky and intended for a single purpose. The intention of the Hydra Trim is a lightweight machine that may take longer to perform a specific task, but it is capable of many tasks.

The development of the wrist was based on the human forearm and wrist, with “bend” and “twist” action. To achieve this action the wrist was split into two rotator units that when combined create the wrist. The rotator units are powered by hydraulic pressure. Hydraulics was chosen because it is the main power source of the Hydra Trim. Thus no other type of control servo would be required.

The Hydra Trim has a total of eight functions, five main working functions, two telescopic and one hydraulic motor function. Only one hand is available to operate the Hydra Trim as the other is required to operate the vehicle, therefore a single joystick was required that could control all eight functions. Standard joysticks were investigated, but at best could only control three proportional axes at once. A stackable modular design was developed. Each module controlled one axis. The modules were assembled to replicate the geometry of the Hydra Trim. Moving the end of the modular joystick causes the Hydra Trim to follow in the same direction at a velocity proportional to the displacement of the joystick.

To control the hydraulic flow a system was required that is capable of operating at least eight functions. A stackable valve system was the best option. Three valve types were considered. The valve types were solenoid proportional, servo and pulsar operated. The pulsar system was chosen as it gave good control at a lower cost than the others did.

An interface between the joystick and the hydraulic valves was required. Using the standard controller that comes with the valves was considered, but each unit can only control three actions. Two options were considered for a controller, these were individual analogue controllers or a digital micro-controller. The analogue controller is much simpler than the micro-controller but is unable to perform intelligent operations. The analogue controller was chosen because it was simple and would speed up the development process.

TABLE OF CONTENTS

ACKNOWLEDGEMENTS	III
SUMMARY.....	IV
LIST OF FIGURES.....	VII
1 INTRODUCTION.....	1
1.1 SOFTWARE.....	1
1.2 OVERVIEW.....	1
2 BACKGROUND	2
2.1 MARKET NICHE.....	2
2.2 OTHER SYSTEMS	2
2.2.1 Bomford Turner Ltd.....	2
2.2.2 McConnel Ltd.....	3
2.2.3 Alamo Industrial Ltd.....	4
2.3 THE HYDRA TRIM.....	5
3 WRIST	8
3.1 REQUIREMENTS.....	8
3.2 ACTUATION.....	9
3.3 DEVELOPMENT.....	9
3.3.1 Counter Rotating Helices.....	11
3.3.1.1 Pressure Requirements.....	13
3.3.1.2 Assembly.....	16
3.3.1.3 Problems.....	16
3.3.2 Rotator Unit.....	16
3.3.2.1 Off The Shelf Rotators.....	16
3.3.2.2 The Helix.....	18
3.3.2.3 Doughnut Piston.....	19
3.3.2.4 Pressure Requirements.....	20
3.3.2.5 Assembly.....	21
3.3.2.6 Materials.....	24
3.4 ASSEMBLY.....	24
4 JOYSTICK	28
4.1 REQUIREMENTS.....	28
4.2 DEVELOPMENTS.....	28
4.2.1 Three Axes on a Two Axis Joystick.....	28
4.2.1.1 Testing.....	28

4.2.1.2	Conclusions.....	30
4.2.2	<i>Standard Three Axis Joystick</i>	31
4.2.3	<i>Miniature Model Joystick</i>	31
5	HYDRAULIC VALVES	34
5.1	REQUIREMENTS.....	34
5.2	AVAILABLE SYSTEMS.....	34
5.2.1	<i>Danfoss</i>	34
5.2.2	<i>Moog</i>	35
5.2.2.1	Torque Motor.....	35
5.2.2.2	Hydraulic Amplifier.....	36
5.2.2.3	Spool Valve.....	36
5.2.2.4	Operation.....	37
5.2.3	<i>Apitech</i>	38
5.2.4	<i>Conclusions</i>	39
5.2.4.1	Danfoss.....	39
5.2.4.2	Moog.....	40
5.2.4.3	Apitech.....	40
6	CONTROLLER	41
6.1	ANALOGUE CONTROLLER.....	41
6.2	MICRO-CONTROLLER.....	42
7	CONCLUSIONS	43
7.1	WRIST.....	43
7.2	JOYSTICK.....	43
7.3	HYDRAULIC VALVES.....	44
7.4	CONTROLLER.....	44
7.5	COST.....	44
8	FUTURE WORK	45
9	REFERENCES	46
	APPENDIX 1: COUNTER ROTATING HELIX DRAWINGS	48
	APPENDIX 2: ROTATOR UNIT DRAWINGS	56
	APPENDIX 3: ROTATOR ASSEMBLY PART DRAWINGS	66
	APPENDIX 4: JOYSTICK DRAWINGS	70

LIST OF FIGURES

Figure 2-1. Bomford Turner B407.....	2
Figure 2-2. Bomford Turner B83-83	3
Figure 2-3. McConnel PA90.....	3
Figure 2-4. McConnel PA7000T.....	4
Figure 2-5. McConnel “Parallel Arm”	4
Figure 2-6. Alamo Industries Slopemower	4
Figure 2-7. Alamo Industries Front Mount Boom Mower.....	5
Figure 2-8. First Prototype.....	6
Figure 2-9. Second Prototype	7
Figure 3-1. Free body diagram	8
Figure 3-2. Geometry Schematic	10
Figure 3-3. Bell Crank Assembly in 5 positions	10
Figure 3-4. Bell Crank Force Relationship	11
Figure 3-5. Counter Rotating Helices	11
Figure 3-6. Double Acting Hydraulic Ram.....	12
Figure 3-7. Two Rams on Counter Rotating Helices.....	13
Figure 3-8. Ram Block with Shaft and Pistons	13
Figure 3-9. Helix pitch diagram. Diameter D , Circumference C , Length L , Angle θ	14
Figure 3-10. Space and Force Diagram for ram force R_f	15
Figure 3-12. Exploded View of Assembly	16
Figure 3-13. Helac HB Series Helical Rotary Actuator	17
Figure 3-14. Helac Rotary Actuator Design.....	18
Figure 3-15. Ball Screw Assembly.....	19
Figure 3-16. Doughnut Piston	19
Figure 3-17. Full exploded view.....	21
Figure 3-18. Assembled Unit	22
Figure 3-19. Vertical Sectioned View.....	22
Figure 3-19. Cross-section of O-ring and Backup	23
Figure 3-21. Diagonally Sectioned View.....	23
Figure 3-22. Horizontal Sectioned View.....	24
Figure 3-22. Machined Dipper Bracket.....	25
Figure 3-23. Base Plate Clamp	26
Figure 3-24. Fully Assembled Wrist	27
Figure 4-1. X-axis look-up array	29
Figure 4-2. Y-axis look-up array	29
Figure 4-3. Z-axis look-up array	29
Figure 4-4. The Hydra Trim model in its starting position.....	30

<i>Figure 4-5. The Hydra Trim model after being moved.....</i>	<i>30</i>
<i>Figure 4-6. Assembled Joystick Module</i>	<i>31</i>
<i>Figure 4-7. Exploded View of Module.....</i>	<i>32</i>
<i>Figure 4-8. Assembled Joystick, isometric view</i>	<i>33</i>
<i>Figure 4-9. Assembled Joystick, front view</i>	<i>33</i>
<i>Figure 5-1. Danfoss electronic proportional valve.....</i>	<i>34</i>
<i>Figure 5-2. Armature.....</i>	<i>35</i>
<i>Figure 5-3. Torque motor.....</i>	<i>35</i>
<i>Figure 5-4. Torque motor – Current applied.....</i>	<i>36</i>
<i>Figure 5-5. Hydraulic Amplifier.....</i>	<i>36</i>
<i>Figure 5-6. The spool Valve</i>	<i>37</i>
<i>Figure 5-7. Servo Valve – Current applied.....</i>	<i>37</i>
<i>Figure 5-8. Servo Valve – Equilibrium.....</i>	<i>38</i>
<i>Figure 5-9. Pilot system.....</i>	<i>38</i>
<i>Figure 5-10. Flow & modulation relationship.....</i>	<i>39</i>
<i>Figure 6-1. Analogue Controller signals.....</i>	<i>42</i>

1 INTRODUCTION

Roadside mowing and tree pruning has always been a job that most people would consider as unpleasant. This project is concerned with the development of a system to make these tasks simpler, safer and more pleasant for the operator.

1.1 Software

This project is involved with the design of a complex mechanical system, which could be done using a modern CAD package. To achieve this, research into what modelling package was best was necessary. Several contenders were considered. These include SolidWorks [1], Mechanical Desktop [2] and CADKEY [3]. CADKEY was disregarded early as it is not as expandable as the other two. Both SolidWorks and Mechanical Desktop have additional software packages that allow for motion, force and stress analysis. The major difference between SolidWorks and Mechanical Desktop, is that SolidWorks is a true three dimensional modelling package, whereas Mechanical Desktop is based on the two dimensional AutoCAD system with a three dimensional toolbox. The choice was finalised to SolidWorks as it handles three dimensional modelling more efficiently. Massey University also uses SolidWorks. This allowed the project to continue while studying at the Turitea campus.

1.2 Overview

This project is involved with the development of a wrist mechanism and hydraulic control system for an agricultural manipulator. The manipulator is called the Hydra Trim and was developed by Pivot Engineering Ltd, Napier [4]. The wrist mechanism is an integral part of making the Hydra Trim a success. The hydraulic control requires not only the valves but also an interface between the operator and the valves.

2 BACKGROUND

2.1 Market Niche

The concept behind the Hydra Trim is to fill a market niche. The Hydra Trim is primarily aimed at regional Councils and private contractors. Most systems available to contractors for roadside mowing, hedge trimming/pruning require separate large bulky single purpose machines. The Hydra Trim is different in that it is smaller, lighter and is able to perform a multitude of tasks by changing the blade mechanism on the end of the wrist. It may take longer to perform a task with the Hydra Trim as it is smaller, but within a matter of minutes it can be performing a completely different task whereas other systems would require a separate machine.

2.2 Other Systems

Of the mowing systems found, most are mounted on the rear of a tractor. They are large and bulky with substantial counter balance weights and require tractors that exceed a minimum weight. As the mowers are mounted at the rear of the tractor the operator has to continually look forward and backward to maintain their correct direction and monitor the mower. As the booms extend vertically from the tractor, when the mower is close to the tractor overhead clearances need to be monitored. Most tractors with these mowers attached have cabs and/or safety cages so that the top of the boom becomes invisible from the normal seated position. This means that the operator must lean back out of the seat to look up for overhead obstacles.

2.2.1 Bomford Turner Ltd.

Bomford Turner Ltd [5] is based in England and produces “Arm Type Flail Mowers”. The smallest machine has a reach of 4.25m with a minimum tractor weight of 2000 kg (Figure 2-1) and the largest has a reach of 8.30m, with a minimum tractor weight of 4600kg (Figure 2-2).



Figure 2-1. Bomford Turner B407

Their entire range is rear mounted with the exception of one model that is front mounted, but a special tractor is required that has the engine to the rear and the cab to the front.



Figure 2-2. Bomford Turner B83-83

2.2.2 McConnell Ltd

McConnell Ltd [6] is based in England and produces “Power Arm Hedge Trimmers”. The smallest machine has a reach of 3.10m with a minimum tractor weight of 1500 kg (Figure 2-3) and the largest has a reach of 7.70m, with a minimum tractor weight of 4500kg (Figure 2-4).



Figure 2-3. McConnell PA90

All of the McConnell “Power Arm Hedge Trimmers” are mounted to the rear of the tractor by either the standard three-point linkage or permanently fixed to the rear axle. These arms feature a parallel arm system (Figure 2-5) that allows adjustment of reach using a single lever without constant adjustment of height.



Figure 2-4. McConnell PA7000T

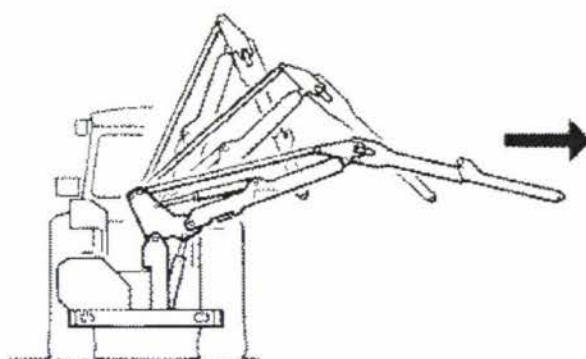

Figure 2-5. McConnell "Parallel Arm"

2.2.3 Alamo Industrial Ltd

Alamo Industrial Ltd [7] has seven manufacturing plants in U.S.A. and four in Europe. They produce tractor-mounted mower and cutters. The smallest machine has a reach of 3.80m and the largest has a reach of 10.25m (Figure 2-6). The minimum vehicle weights were not disclosed.



Figure 2-6. Alamo Industries Slopemower

The 10.25m boom requires the tractor to have an additional 640kg weight put on the opposite rear wheel to the boom. Their range includes rear mount, mid mount and front mount mowers. The front mount mower has the same criteria for the Bomford Turner front mount mower in that a specialised tractor must be used (Figure 2-7).



Figure 2-7. Alamo Industries Front Mount Boom Mower

2.3 The Hydra Trim

The first prototype (Figure 2-8) Hydra Trim that was built consisted of a central vertical mast mounted onto a Land Rover stub axle allowing it to rotate about a vertical axis. Connected at the top of the mast was the main boom that extended horizontally and was controlled by a hydraulic ram. The dipper extended vertically downwards from the end of the boom in a similar fashion. The wrist consisted of a single axis joint controlled by a hydraulic ram. A hydraulic motor at the top of the dipper drove the main drive for the cutter on the end of the wrist. The power was transferred to the cutter via a long flexible shaft similar to that found in shearing sheds, used to drive the shearer's hand piece. The concept of the boom and dipper arrangement worked very well but the drive mechanism for the cutter would continually break where the wrist pivoted.

When the second prototype (Figure 2-9) was built the geometry of the boom and dipper remained the same with the exception of the actuation of the dipper. Instead of the hydraulic ram being mounted to the boom it was mounted to the mast. The desired effect was to achieve a parallel geometry similar to the McConnel system (section 2.2.2). But as the hydraulic ram was used as one of the parallel arms difficulties were encountered. When the ram was altered the geometry would change causing the positioning of the cutter to become unnatural to the operator and occasionally jamming the linkages. The cutter motor was moved from the top of the dipper to the wrist, thus overcoming the drive mechanism problems. The wrist had another axis added allowing it to be moved in two directions. To activate the wrist, two hydraulic rams were used to move the upper and lower wrists respectively in the appropriate direction. The

problem was the two motions were not mutually exclusive. Before the second movement could be activated the first had to be returned to the centre position; otherwise the wrist would bind and damage could be inflicted on the wrist. The rams were connected via a bell crank arrangement to the wrist mechanism. This restricted the wrist to less than 180° of motion due to the ram and wrist approaching an infinite gain situation at the end of travel. Thus the wrist suffered from a lack of range of motion.

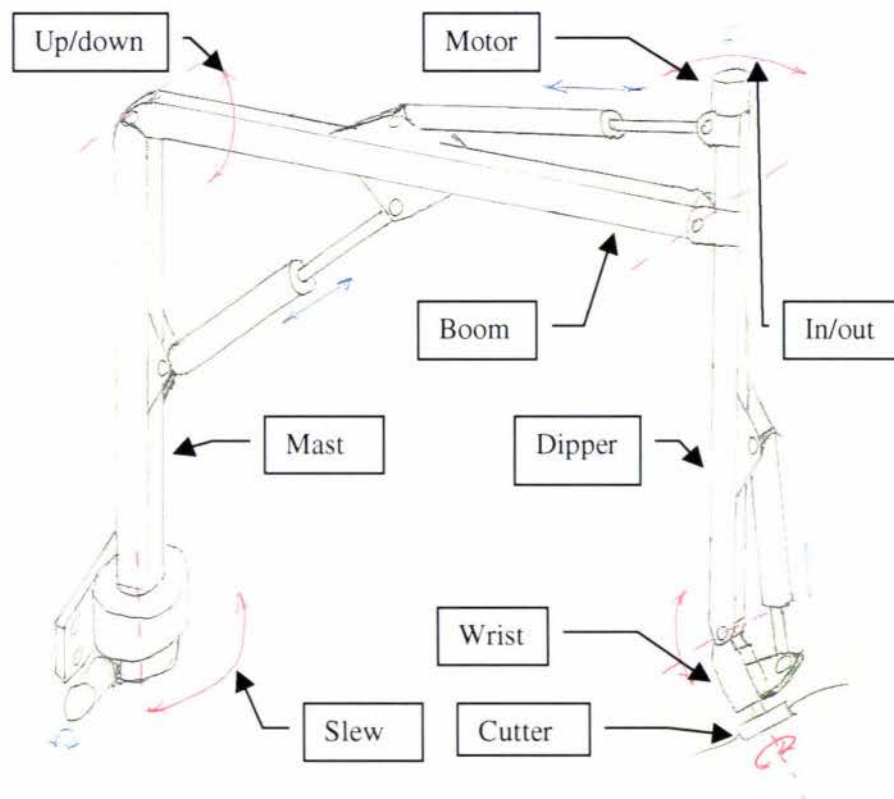

Figure 2-8. First Prototype

The control consoles for both of these prototypes were bulky and contained several levers and switches. This was difficult to use as the operator could only use one hand, as the other is required on the steering wheel of the tractor.

From the testing of the first two prototypes the main slew mechanism, boom and dipper geometry was finalised to a system similar to the first prototype, without the parallel arm arrangement on the second prototype. The slew action of the mast, the up/down action of the boom and the in/out action of the dipper constitute the three main operations of the Hydra Trim. By adding the bend and twist motion of the wrist, brings the count to five.

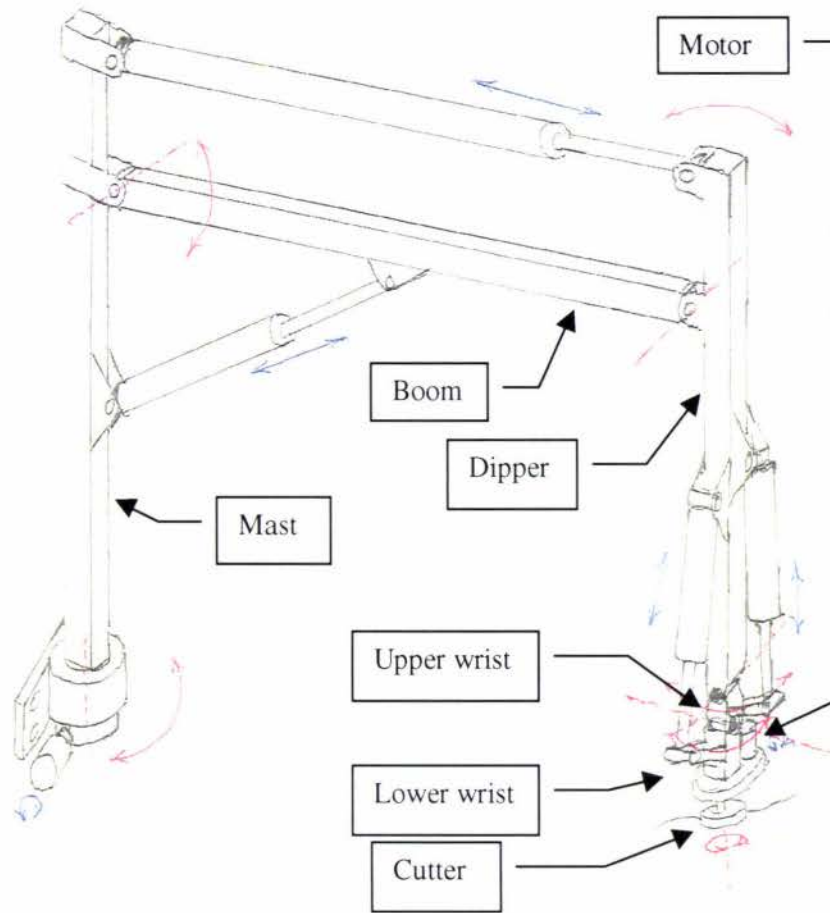

Figure 2-9. Second Prototype

3 WRIST

3.1 Requirements

The main requirements of the wrist were to hold and move a mass of 10 kg displaced at a distance of 400 mm from the centre of rotation and rotate 360° within 5 seconds, taking no longer than ¼ second to reach this rotational velocity from stationary. The wrist had to be able to achieve a complete spherical range of movement with the exception of avoiding the dipper.

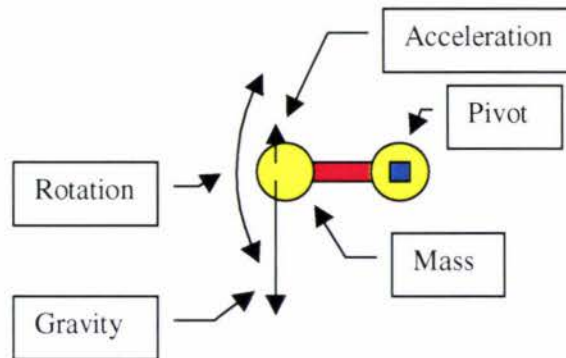

Figure 3-1. Free body diagram

When considering the torque applied to the wrist during normal operation (Figure 3-1), the peak would be achieved when the wrist is accelerating the mass up or decelerating it while it is coming down. Thus the acceleration due to gravity and the acceleration applied to move the mass sum together.

$$\omega = \frac{\theta}{t}$$

$$\omega = \frac{2\pi}{5}$$

$$\omega = 1.26 \text{ rad / s}$$

Equation 3-1 for calculating rotational velocity ω for given rotation θ and time t .

$$\alpha = \frac{\omega - \omega_0}{t}$$

$$\alpha = \frac{1.26 - 0}{0.25}$$

$$\alpha = 5.03 \text{ rad / s}^2$$

Equation 3-2 for calculating rotational acceleration α for given initial rotational velocity ω_0 , final rotational velocity ω and time t .

$$a = r\alpha$$

$$a = 0.4 \times 5.03$$

$$a = 2.01 \text{ m/s}^2$$

Equation 3-3 for calculating linear acceleration a for given radius r and rotational acceleration α .

$$T = FD$$

$$F = m\Sigma a$$

$$\Rightarrow T = m\Sigma aD$$

$$T = 10 \times (9.81 + 2.01) \times 0.4$$

$$T = 47.28 \text{ Nm}$$

Equation 3-4 for calculating torque T for given force F at distance D . Force F is given by mass m and the sum of accelerations a .

This equates to a torque of 47.28 Nm applied to the rotation axis.

3.2 Actuation

Due to the environment and the available power sources, the choice of actuation was straightforward. Because most tractors do not have air compressors and the wrist needs to be infinitely variable and have the ability hold its position then pneumatics were disregarded.

As all tractors can supply both electric and hydraulic power then the choice of actuation had to be between these two. Due to the torque requirements, using electric motors would require considerable gearing down to magnify the torque enough to hold the wrist in the desired position. Adding a gearbox to the wrist would increase the weight causing the payload to be reduced and reduce the speed response of the wrist. When considering all of this information, using hydraulic power is the best option. All the other actions of the Hydra Trim use hydraulics, so that using hydraulic power for the wrist will allow a common power pack to be used and reduce the complexity of the controller.

3.3 Development

To overcome the problems discussed in section 2.3 the geometry of the wrist needed to be remodelled. The “universal joint” type arrangement was discarded in favour of the geometry similar to the human forearm and wrist. The wrist has two rotational axes, one longitudinally (“twist”) along the dipper and the second, perpendicular (“bend”) to the first (Figure 3-2).

The reason for using this geometry was to overcome the problem of effectively driving the wrist. Unlike the “universal joint” method, the mechanisms could be separated allowing for

mutually exclusive control of each action. This removed the problems of binding that were inherent in the second prototype.

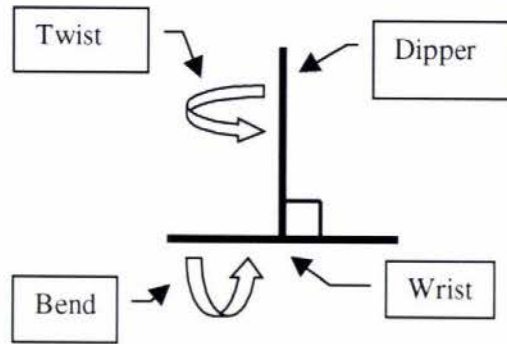

Figure 3-2. Geometry Schematic

To create more range of movement than the prototypes a new actuation system needed to be designed. Bell cranks will always be plagued with a non-linear relationship between output torque and input hydraulic pressure. Figure 3-3 shows an example bell crank arrangement in five different positions.

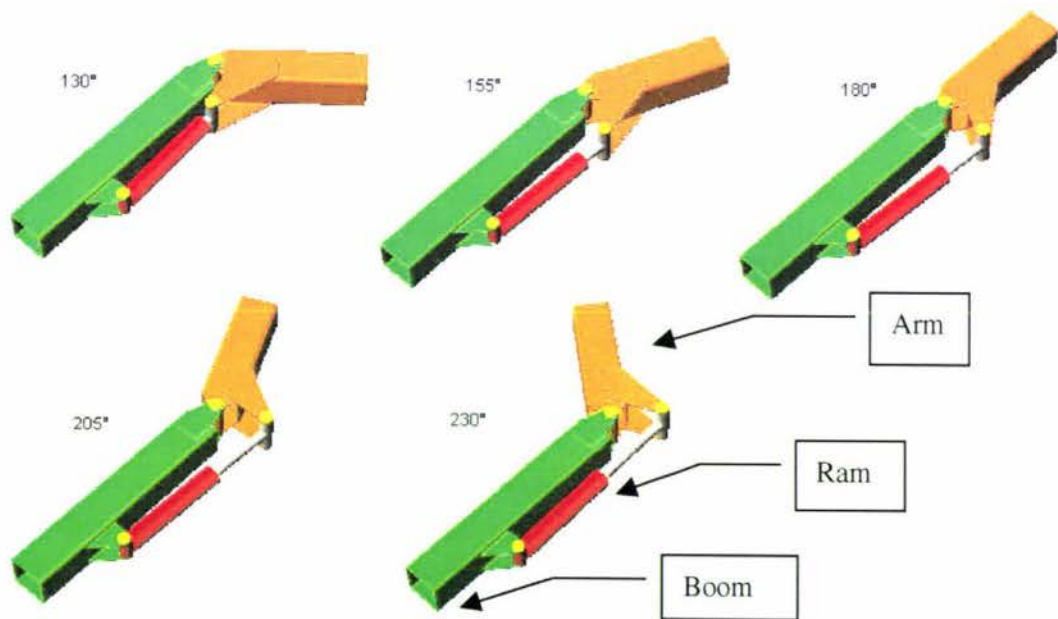

Figure 3-3. Bell Crank Assembly in 5 positions

The graph in Figure 3-4 shows the non-linear relationship between the displacement of the ram and the force applied to achieve equal torque.

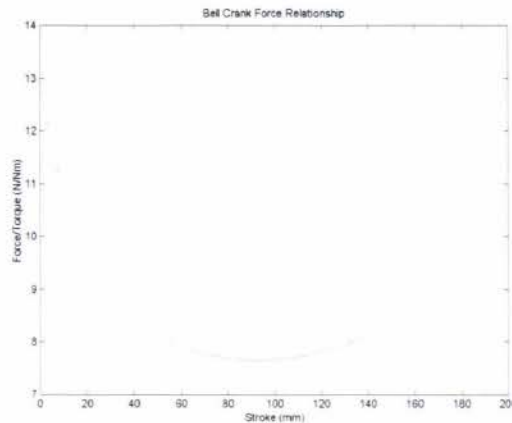

Figure 3-4. Bell Crank Force Relationship

To obtain a linear relationship, either a rack and pinion or a linear ram operating a helix is required. The difference between the two is that the rotational axis of the helix is in line with the travel of the ram while the rack and pinion is perpendicular to each other. With the rotational axis in line with the ram the helix method is considerably more compact, so was chosen for the design.

The following sections detail the development of the wrist mechanism.

3.3.1 Counter Rotating Helices

Mr Greg Jensen of Pivot Engineering Ltd [4] first proposed the concept of using counter rotating helices (Figure 3-5) as a method of transforming linear into rotational motion at the beginning of the project. For detailed drawings of the counter rotating helix design, see Appendix 1. This design was used as the starting point for further development. Double acting hydraulic rams (Figure 3-6) do not have the same displacement to volume ratio for the inward and outward stroke. The spear within the ram is the cause of this difference as it reduces the working surface area of the piston for the return stroke.

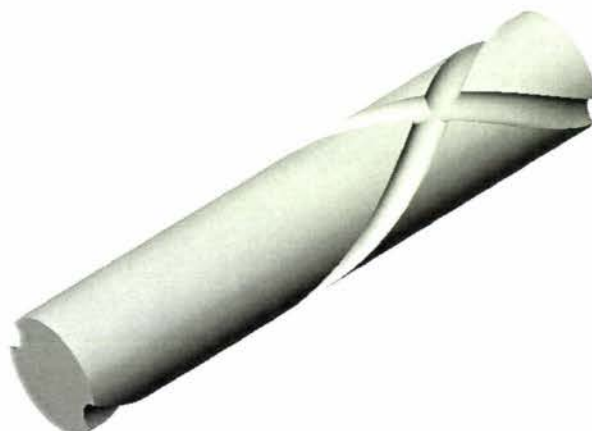

Figure 3-5. Counter Rotating Helices

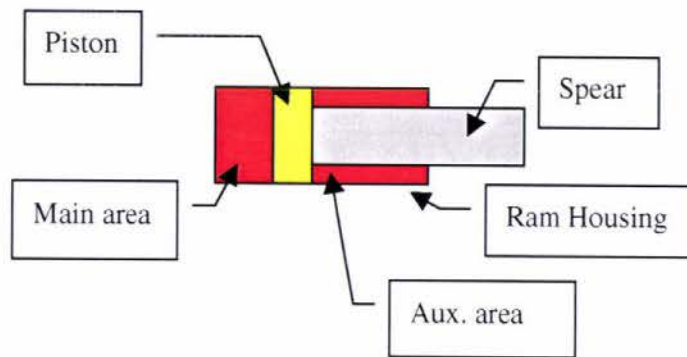

Figure 3-6. Double Acting Hydraulic Ram

The ram size proposed had a piston diameter of 25 mm and a spear diameter of 19 mm. Using Equation 3-5 and Equation 3-6 it is possible to calculate the main and auxiliary working area of the ram.

$$A = \frac{\pi D^2}{4}$$

$$A = \frac{\pi \times 25^2}{4}$$

$$A = 490.87 \text{ mm}^2$$

Equation 3-5 for calculating the main area A of piston with diameter D

$$A = \frac{\pi(D^2 - d^2)}{4}$$

$$A = \frac{\pi(25^2 - 19^2)}{4}$$

$$A = 207.35 \text{ mm}^2$$

Equation 3-6 for calculating the auxiliary area A of piston with diameter D and a spear of diameter d

The main and auxiliary working areas are 490.87 and 207.35 mm² respectively. This corresponds to the auxiliary area being 42.24 % of the main area. Thus the inward stroke applies 42.24 % of the force that the outward stroke applies at the same operating pressure. Because of this two rams of the same size are used on the counter rotating helices. An equal displacement to volume ratio is achieved by using two rams that work together, one extending the other retracting. The counter rotating helices allows the two rams to operate in this manner (Figure 3-7).

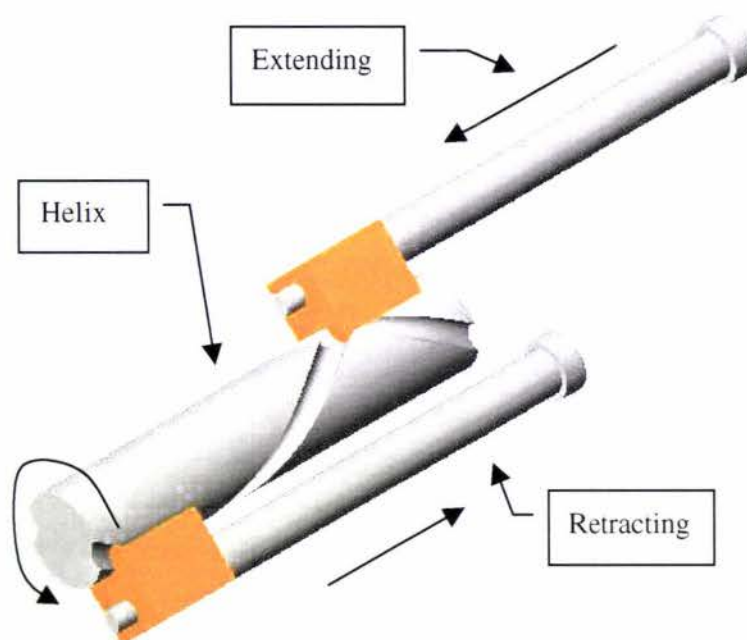

Figure 3-7. Two Rams on Counter Rotating Helices

To allow for both “twist” and “bend”, two counter rotating helix shafts were required. For a compact design, the rams were set in a square block that had four holes (Figure 3-8). The holes were paired allowing one helix shaft at one end and another at the other end.

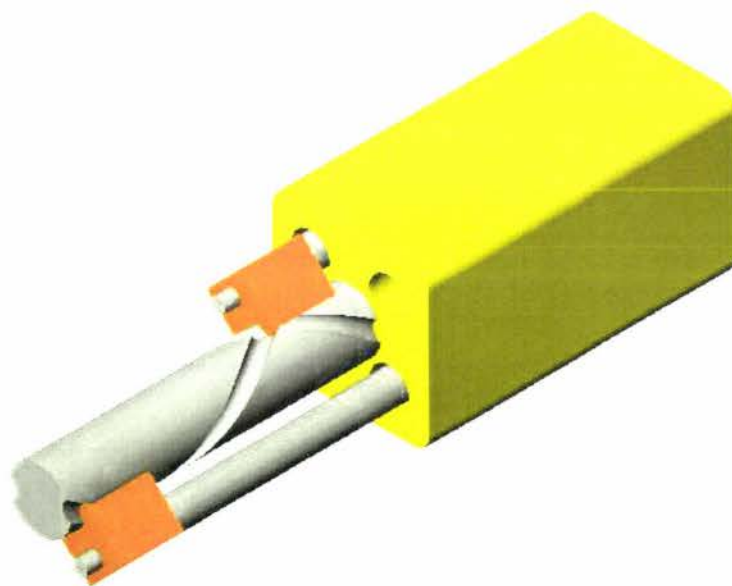

Figure 3-8. Ram Block with Shaft and Pistons

3.3.1.1 Pressure Requirements

When considering the capacity requirements of the wrist the operating hydraulic pressure required was calculated. Firstly the helix dimensions were used to calculate the pitch angle (Figure 3-9).

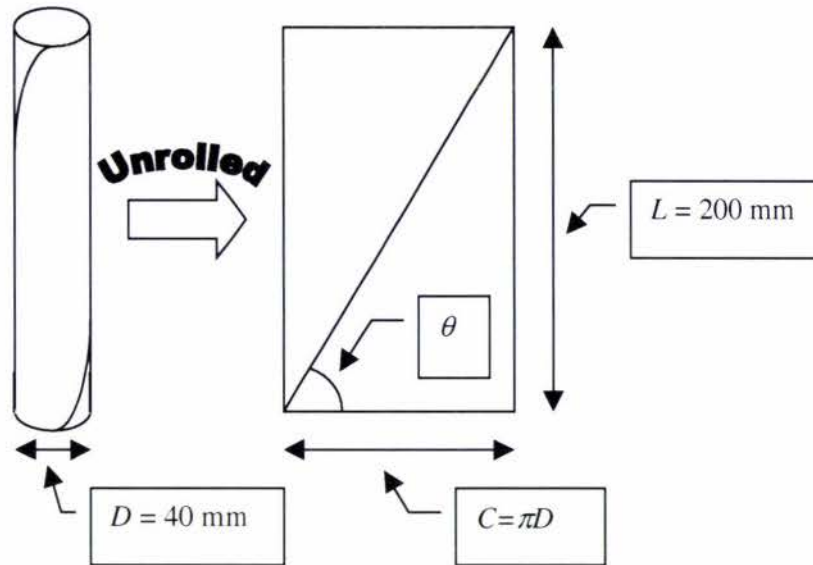

Figure 3-9. Helix pitch diagram. Diameter D , Circumference C , Length L , Angle θ

$$\tan \theta = \frac{L}{C}$$

$$\tan \theta = \frac{L}{\pi D}$$

$$\tan \theta = \frac{200}{\pi \times 40}$$

$$\theta = 57.86^\circ$$

Equation 3-7 for calculating pitch angle θ from length L and diameter D

Using the torque applied and the pitch angle, the force applied to the hydraulic rams was calculated. Due to the difference in the main and auxiliary piston area of the rams, the force applied to each ram was different. The working piston area was defined as the main piston area of the extending ram and the auxiliary piston area of the retracting ram. The main piston area as a ratio of the total working piston area is 70.30 % and the auxiliary piston area ratio is 29.70 %. Therefore the ram that extends takes 70.30 % of the load and the guide for the extending ram also takes 70.30 % of the load. The force G_f on the guide for the ram that is extending is obtained from Equation 3-8.

$$G_f = \frac{2T}{D} \times 70.30\%$$

$$G_f = \frac{2 \times 47.28}{0.04} \times 70.30\%$$

$$G_f = 1662.07N$$

Equation 3-8 for calculating extending ram guide force G_f from torque T and diameter D

The space diagram in Figure 3-10 and Equation 3-9 was used to calculate the resultant ram force R_f .

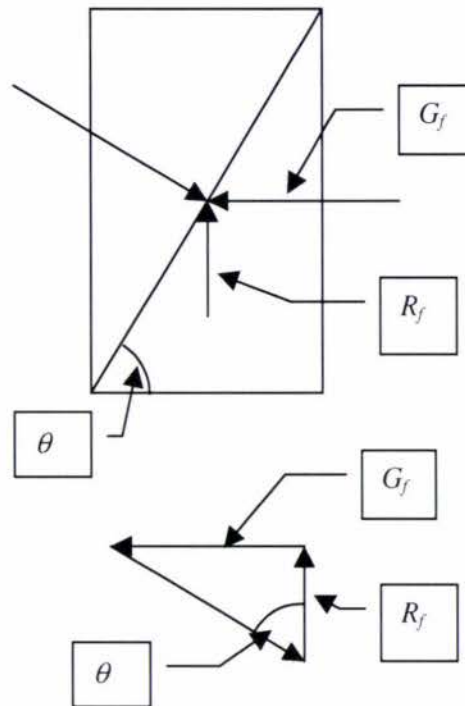

Figure 3-10. Space and Force Diagram for ram force R_f

$$R_f = \frac{G_f}{\tan \theta}$$

$$R_f = \frac{1662.07}{\tan(57.86^\circ)}$$

$$R_f = 1044.31N$$

Equation 3-9 for calculating ram force R_f .

Once the ram force was obtained the pressure required on the piston was calculated using Equation 3-10.

$$P = \frac{R_f}{A}$$

$$P = \frac{1044.31}{490.87}$$

$$P = 2.13MPa \Leftrightarrow 308.56psi$$

Equation 3-10 for calculating pressure P

Because the ratio of force has already been taken into account between the extending and retracting ram, the pressure in the retracting ram is also 2.13 MPa. Most tractors with hydraulic

systems are capable of achieving pressures of up to 20 MPa, so 2.13 MPa is well within the design constraints.

3.3.1.2 Assembly

The slides on the helix were held in place by a block that had the same outside dimensions as the ram housing. This allowed the geometry to be continuous in design. The block (Figure 3-11) has slots within, which are the same size as the slides. This allowed the slides to move up and down with the rams, but not sideways thus transmitting the linear motion into rotational.

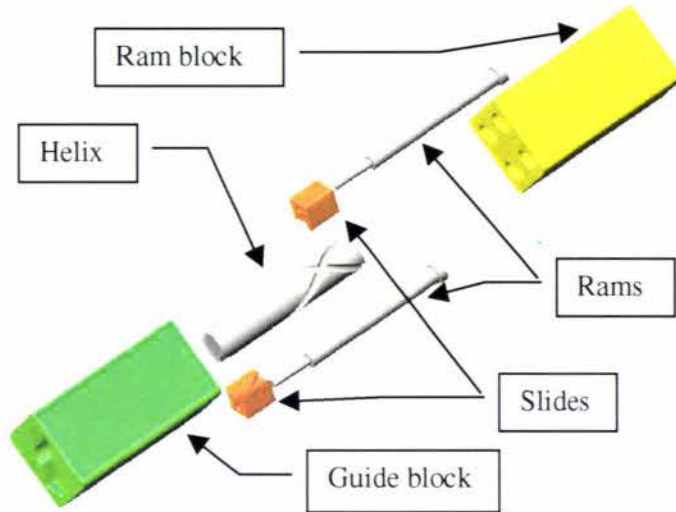

Figure 3-11. Exploded View of Assembly

3.3.1.3 Problems

The rotational axes of the two shafts are concentric, thus to allow for the wrist geometry in Figure 3-2 a right angle form of transmission is required. Right angle bevel gears are the best option. The drawback of using gears is backlash, which is inherent in all gear systems. The guides also introduce backlash into the system, due to machining tolerances.

3.3.2 Rotator Unit

Attempts to make the unit shorter considered removing the rams and applying hydraulic pressure to the guides themselves. The square design of the guides would not allow a good seal, but the concept caused an inspiration. Replacing the counter rotating helices with co-rotating helices so the guides travel in the same direction, and replacing the guides with a doughnut shaped piston that encompassed the rotating shaft, a rotator unit was developed.

3.3.2.1 Off The Shelf Rotators

When considering the concept of a rotator unit, research was conducted into using off the shelf rotators. Several brands were found that all appeared to work on similar concepts within each

category. The three main types of rotator found were vane, rack-and-pinion and helical. The vane type has a shaft that is connected to a vane that wipes the edges of a cylindrical volume. Supplying pressure to either side of the vane causes it to move, thus rotating the shaft. Due to the space occupied by the inlets the vane type rotator has a maximum rotation of 280° . Vane rotators with multiple vanes for increased torque have even less rotation. Vane type rotators also suffer from high internal leakage compared with other systems, which means that once set to a position holding a load, the rotator can creep down. The rack and pinion type as discussed in section 3.3 is not a compact design. The units found were short along the axis of rotation, but had cylinders extended sideways to accommodate the pistons. This was not acceptable for the wrist design. Of the designs found the helical type was the best option.

Helac Corporation [8] produces helical rotary actuators (Figure 3-12). Other companies including HKS [9] produce helical rotary actuators as well, but for simplicity Helac Corporation is used to explain the design.

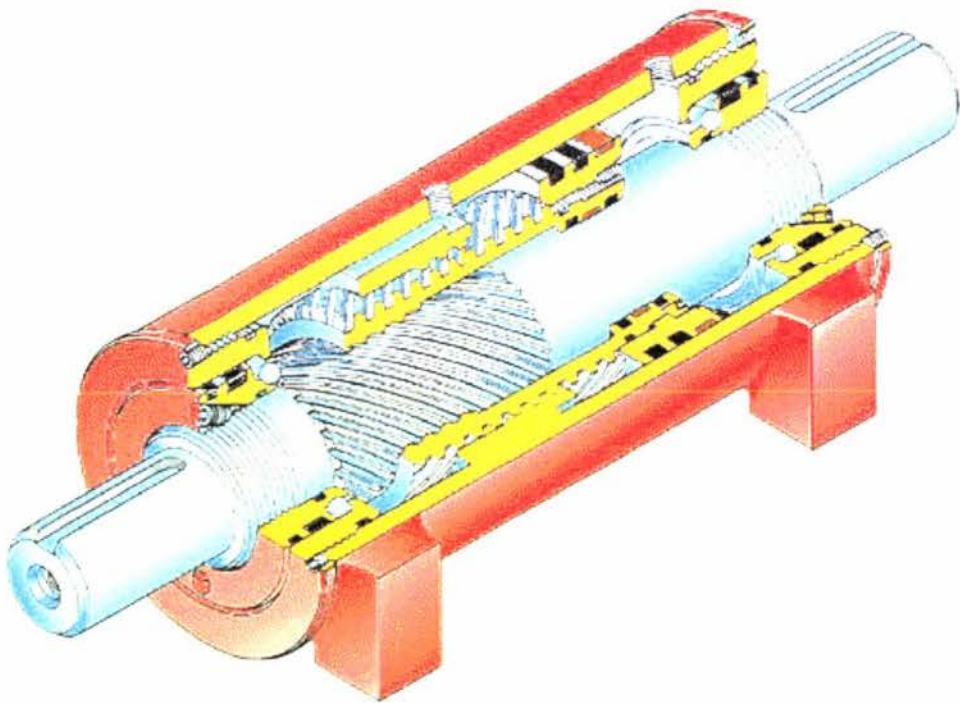

Figure 3-12. Helac HB Series Helical Rotary Actuator

Helac rotators consist of two moving parts. The piston sleeve and the output shaft. The piston not only reciprocates but also rotates. The output shaft only rotates. The piston is hydraulically sealed against the housing and the shaft. It is stroked back and forth by hydraulic fluid pressure just like a conventional hydraulic cylinder. The piston sleeve has helical spline teeth machined on the outside. This spline is engaged with a stationary ring gear that is part of the rotator housing. Thus as the piston travels axially it also rotates. The piston sleeve is also engaged to the output shaft via a helical spline of the opposite rotation. Reciprocation of the piston causes

relative rotation between the piston sleeve and the output shaft, which adds to the piston sleeves own concurrent rotation. A schematic of the operation of the rotator is in Figure 3-13

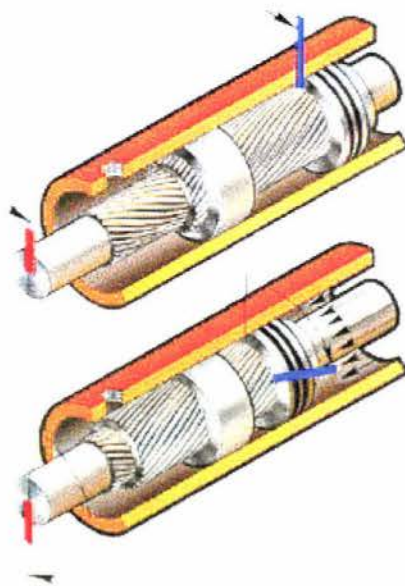

Figure 3-13. Helac Rotary Actuator Design

In the top illustration, the red bar on the shaft and blue bar on the piston indicate their starting positions. Arrows indicate the directions they will travel. The housing with integral ring gear remains stationary. As fluid pressure is applied in the lower illustration, the piston is displaced axially while the helical gearing causes the simultaneous rotation of the piston and the shaft. The double helix design compounds the rotation of the unit. The rotation of the shaft is about twice that of the piston.

The specification sheet for the Helac rotary actuators states that the actuators are primarily intended as positioning and holding devices. Operating speeds should not continuously exceed 20 seconds per complete cycle for a 360° actuator. This speed of operation is very slow and as the wrist would be moving most of the time the overall productivity of the Hydra Trim would be decreased. For the wrist to operate efficiently the speed would need to be increased, which would significantly increase wear and reduce the life of the rotator. The smallest rotator, model 2K would be able to withstand the torque requirements of the wrist. The 2K outputs a torque of 43.27 Nm at a pressure of 3.45 MPa or 500 psi. Due to the specifications and the intended purpose of the rotators, they were discarded as an option for the wrist development.

3.3.2.2 The Helix

Using a unidirectional helix makes machining simple and also allows the use of off the shelf parts. Standard bolts with extremely coarse pitch are an option, but these cannot be preloaded which introduces backlash. Bolts are designed for single use, tightened and left tight. Multiple

cycles will cause excessive wear and friction would be high. Precision Ball Screw Assemblies (Figure 3-14) were considered the best option. Ball screws are designed for multiple cycles and can be preloaded which removes any backlash within the system. The balls act as bearings between the nut and the thread so friction is reduced to a minimum.



Figure 3-14. Ball Screw Assembly

The make and model of ball screw used for the project is a THK WTF2550-3 [10]. The thread diameter is 25 mm and the lead is 50 mm per revolution. After consultation with a THK representative at SAECO Bearings and Transmissions [11], the following loading values were obtained. Based on the dynamic capacity of the ball nut which is 10.4 kN the maximum torque for 10^6 revolutions is 93.7 Nm. The life of the ball screw with the design required torque of 47.28 Nm is 11.2×10^6 revolutions. The maximum torque that will overload the raceway is 242 Nm.

3.3.2.3 Doughnut Piston

The concept of the doughnut piston (Figure 3-15) is to allow the output shaft of the rotator to go through the centre of the piston. Interfacing with other components is shown in Figure 3-16. For detailed drawings of the rotator design, see Appendix 2.

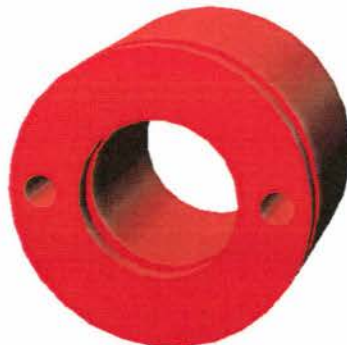

Figure 3-15. Doughnut Piston

Two pistons are involved within the design. One is used for pushing the ball screw nut in one direction; the second is used for the return stroke. Because both pistons have the same working surface area, then the pressure to torque ratio for movement in either direction is the same. The

dimensions of the piston are an outside diameter of 80 mm and an internal diameter of 40 mm. Using Equation 3-11 the working surface area of the ram was obtained.

$$A = \frac{\pi(D^2 - d^2)}{4}$$
$$A = \frac{\pi(80^2 - 42^2)}{4}$$
$$A = 3641.11\text{mm}^2$$

Equation 3-11 for calculating the working area A of piston with an external diameter D and an internal hole of diameter d

3.3.2.4 Pressure Requirements

The calculations for the hydraulic pressure are the same as in section 3.3.1.1. The diameter of the helix is 25 mm and the length is 50 mm. Firstly the pitch angle is calculated.

$$\text{Tan}\theta = \frac{L}{C}$$
$$\text{Tan}\theta = \frac{L}{\pi D}$$
$$\text{Tan}\theta = \frac{50}{\pi \times 25}$$
$$\theta = 32.48^\circ$$

Equation 3-12 for calculating pitch angle θ from length L and diameter D

The torque that is applied to the ball screw transmits a force G_f to the nut. This force is calculated in Equation 3-13.

$$G_f = \frac{2T}{D}$$
$$G_f = \frac{2 \times 47.28}{0.025}$$
$$G_f = 3782.60\text{N}$$

Equation 3-13 for calculating guide force G_f from torque T and diameter D

Using Figure 3-10 it is possible to calculate the ram force R_f .

$$R_f = \frac{G_f}{\text{Tan}\theta}$$
$$R_f = \frac{3782.60}{\text{Tan}(32.48^\circ)}$$
$$R_f = 5941.69\text{N}$$

Equation 3-14 for calculating ram force R_f

Once the ram force was obtained the pressure required on the piston was calculated using Equation 3-15.

$$P = \frac{R_f}{A}$$

$$P = \frac{5941.69}{3641.11}$$

$$P = 1.63\text{MPa} \Leftrightarrow 236.68\text{psi}$$

Equation 3-15 for calculating pressure P

As discussed in section 3.3.1.1 the pressure requirements are well within the design constraints.

3.3.2.5 Assembly

The concept for the system was to hold the nut so it cannot rotate, but can move axially along the shaft. Moving the nut axially in relation to the shaft causes the shaft to rotate. Therefore the shaft must be held axially. This was done using tapered roller bearings. The nut assembly was allowed axial travel but not rotation with the use of four keys that are placed parallel with the shaft. The full exploded view (Figure 3-16) shows all the parts involved in the design.

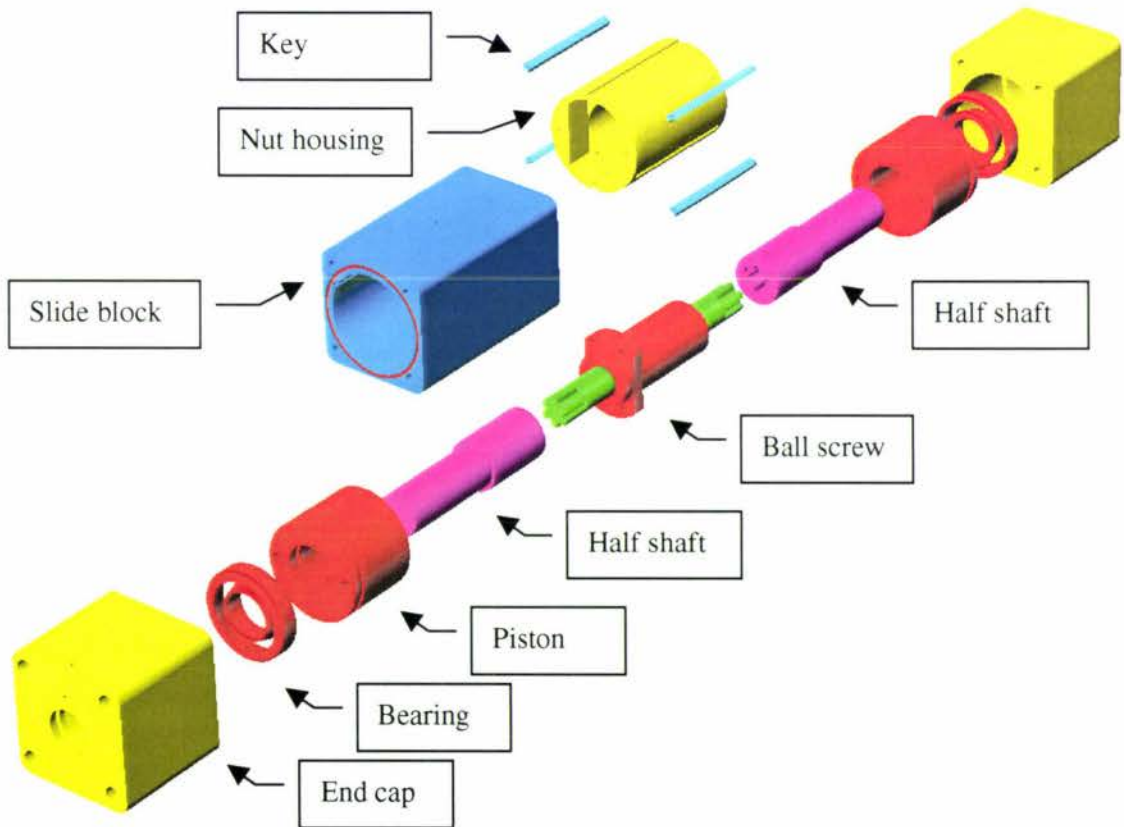

Figure 3-16. Full exploded view

With the unit fully assembled, only the slide block, end caps and the ends of the two half shafts are visible. To meet the requirements of the design the unit has a rotational range of 360°.

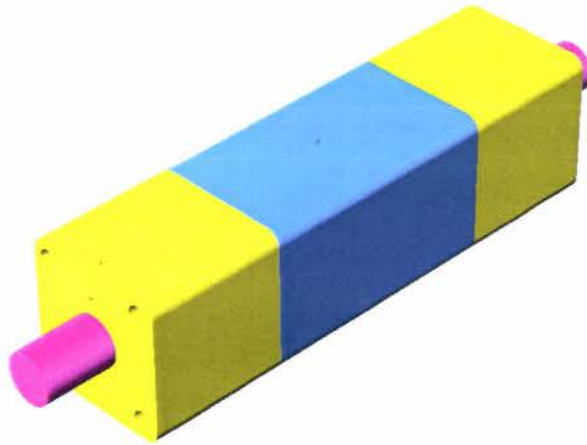

Figure 3-17. Assembled Unit

Understanding the workings of the unit requires looking inside when it is assembled. This is achieved by using a sectioned view of the unit. The vertical sectioned view (Figure 3-18) shows the oil porting in detail while the diagonal view (Figure 3-20) shows the bolt holes that hold the unit together and the horizontal view (Figure 3-21) shows the bolt holes that hold the pistons to the nut housing.

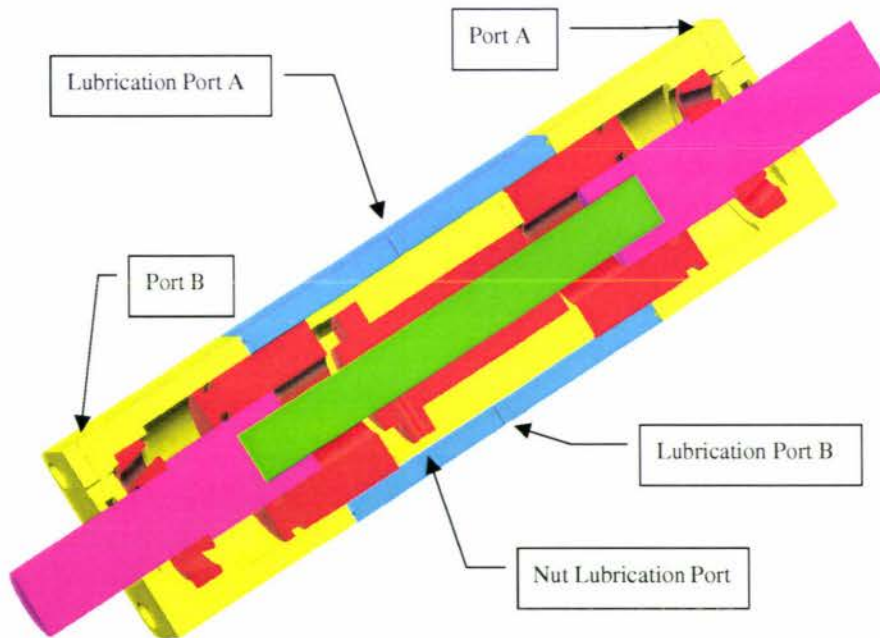

Figure 3-18. Vertical Sectioned View

Port A and B are the control ports for the main operation of the unit. Pumping hydraulic oil into port A causes the piston, nut housing and the other piston to move to the left. This causes the shaft to rotate in the clockwise direction. Hydraulic oil is also expelled from port B at the same rate as the oil entering port A. The lubrication for the tapered bearings is supplied by the oil that is used to operate the unit, as the bearings are located in the same volume with the pistons. The

lubrication ports are used as an inlet and outlet of hydraulic oil that bleeds off from the hydraulic motor back to the tank. The oil travels from one side of the slide block to the other passing through the ball screw. This keeps the ball screw, the nut housing and the low-pressure side of the piston seals lubricated and also acts as a coolant. All of the seals within the unit are standard O-rings. With the exception of the two O-rings between the end caps and the slide block, all the seals use Backups to stop the O-ring from extruding, which reduces its life. Figure 3-19 shows a cross-sectional view of an O-ring and a Backup installed correctly.

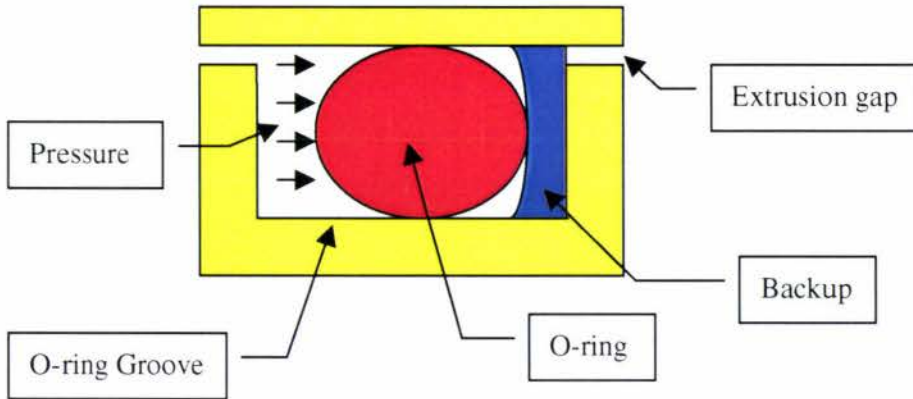

Figure 3-19. Cross-section of O-ring and Backup

If an O-ring is installed without a Backup in high-pressure situations the O-ring can extrude through the extrusion gap.

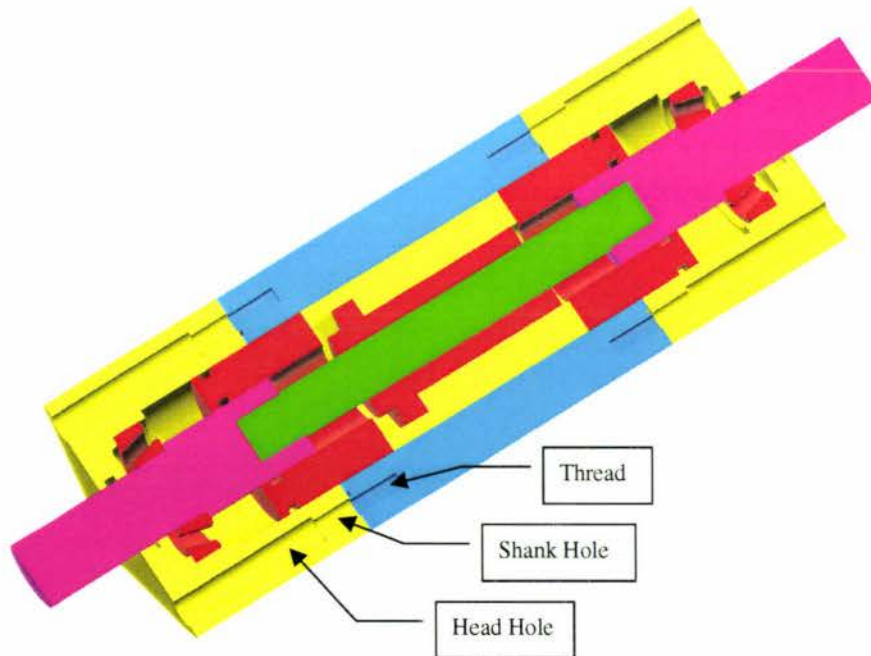

Figure 3-20. Diagonally Sectioned View

To reduce the length of the bolts used the head hole was made longer allowing the shank hole to be short. Short bolts deform less for the same load compared with longer bolts. Thus short bolts do not have to be as tight, which reduces the overall stress of the assembly. Internal hex drive bolts were used. These were used because the head is round and the internal drive means the head hole only needs to be big enough to fit the head of the bolt. This reduces the amount of machining and does not sacrifice valuable strength.

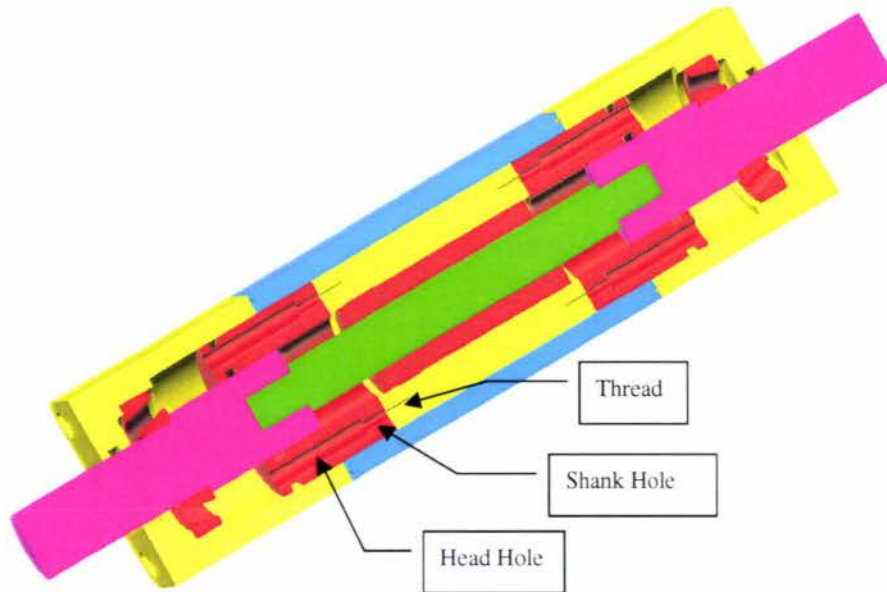

Figure 3-21. Horizontal Sectioned View

3.3.2.6 Materials

The rotator unit is made from mild steel. The slide block and end caps are milled from a 100 mm square billet of the appropriate length. The two pistons and the nut housing are milled from an 80 mm diameter solid shaft. Using mild steel allows for easy machining and a durable material for the environment that the wrist is going to be operating within. The keys are made of high tensile steel to be able to withstand the shearing force that is applied. The bearings used are NTN ET-30207 tapered roller bearings [11]. This type of bearing allows for both axial and radial loads, so is suited best for the job. The bearings are required to withstand the axial force supplied by the pistons and the radial loads applied by the weight of the wrist mechanism. The ball screw used was discussed in section 3.3.2.2.

3.4 Assembly

The rotator unit is only half of the wrist. Two units are required for full functionality of the wrist. The first unit, which is used for the “twist” action, is mounted to the dipper with a machined bracket (Figure 3-22). The bracket is fitted and welded inside a 100 mm square box section with a wall thickness of 6 mm. The bracket has four bolt holes that correspond to the

holes in the end of the rotator. These are used to mount the rotator to the bracket. The holes in the rotator are not only large enough to accept the heads of the bolts that hold the unit together, but are threaded so that the rotator can be bolted to the bracket. For detailed drawings of the assembly components, see Appendix 3.

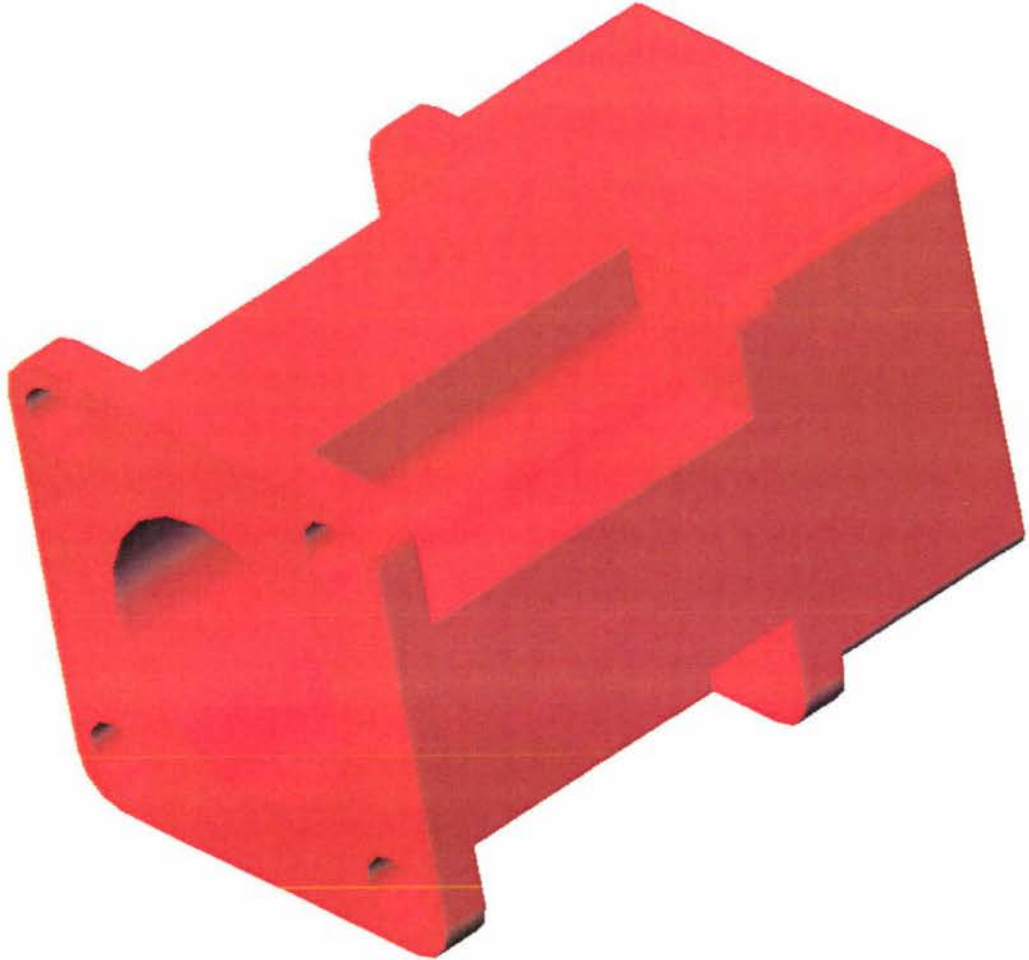

Figure 3-22. Machined Dipper Bracket

The bracket has indents to allow for the insertion of the bolts through the holes and into the rotator unit. The box section beam of the dipper fits over the end of the bracket that is machined down. This allows for a tight fit that holds the bracket firmly to the dipper.

Affixing the second rotator unit requires a bracket that attaches to the output shaft of the first unit. This allows the “twist” motion to be transferred to the second unit that applies the “bend” motion. The bracket (Figure 3-23) consists of two identical base plates, but one has an added boss that clamps to the output shaft of the first unit. The boss has a split along one side that allows it to be tightened to the output shaft by a bolt. This with a keyway holds the clamp in place. The two base plates clamp around the centre of the “bend” unit holding it in place. The base plates are held together by four bolts.

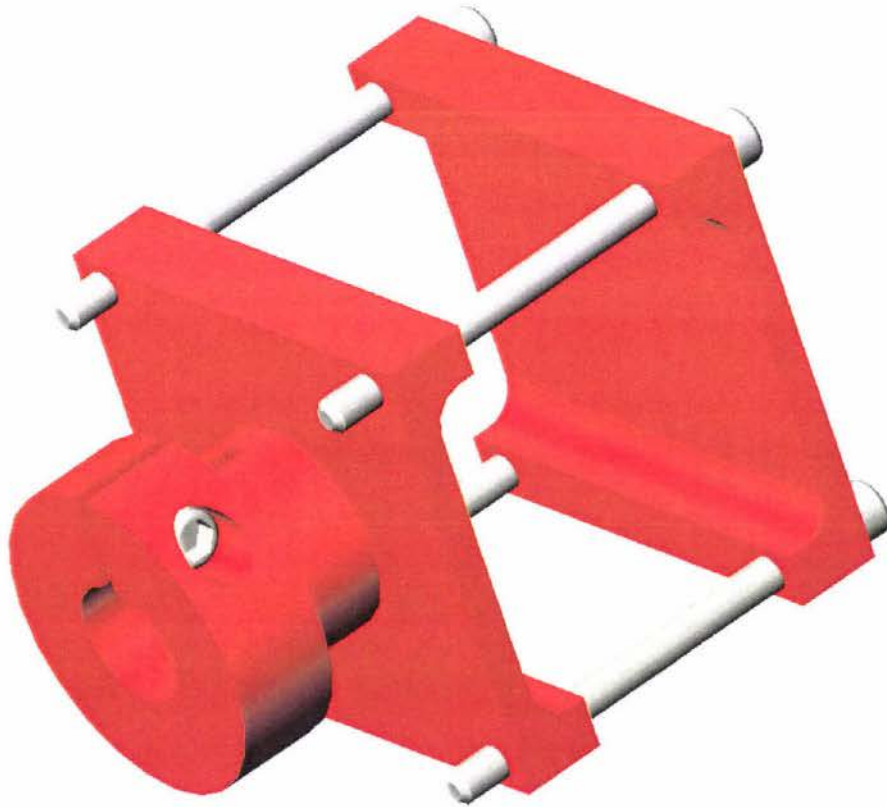

Figure 3-23. Base Plate Clamp

To attach the hydraulic motor to the end of the wrist an “S” shaped bracket was developed (Figure 3-24). This bracket is symmetrical in design, which allows it to be used for both output shafts of the “bend” unit. One bracket is attached to each of the output shafts by a clamping system similar to the base plate in Figure 3-23.



Figure 3-24. End bracket

When fully assembled (Figure 3-25) the two units perform the full requirements of the wrist design.

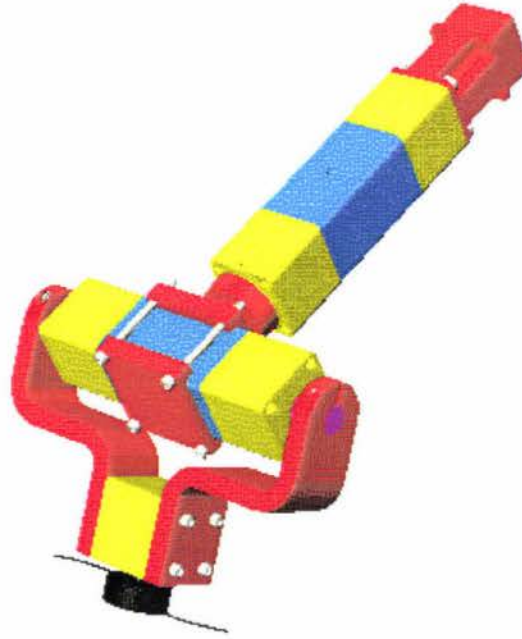

Figure 3-25. Fully Assembled Wrist

4 JOYSTICK

To make the Hydra Trim easy to use for the operator the control system needed to be simple and feel like second nature. The Hydra Trim is designed to be used while the vehicle is moving. The controls need to be operated by one hand, as the other is required to operate the vehicle.

4.1 Requirements

The Hydra Trim has a total of eight functions, five main working functions (section 2.3), two telescopic and one hydraulic motor function; thus a two axis joystick would be inadequate. Most proportional joysticks that are available on the market are two axis joysticks with the exception of a few that have a third proportional axis on the handle. However even a three-axis joystick would lack the necessary control capability.

4.2 Developments

Several different concepts were considered when developing the joystick mechanism. These are detailed below.

4.2.1 Three Axes on a Two Axis Joystick

Manipulating the output of a two-axis joystick, three operations would be controlled. The output of the two-axis joystick was fed into three look-up tables producing the control variables for three separate operations. The addition of a switch at the top of the joystick allowed for six operations to be controlled, but only three at one time. The method used to implement the system consisted of a standard two-axis joystick that outputs its co-ordinates to a decoder, which then uses these values to reference a look up table for the three axes. The simulation was done within MATLAB [12].

4.2.1.1 Testing

A two dimensional grid was set-up to receive co-ordinates from the computer mouse as it wiped across it. The grid outputs x and y values were used for the rest of the simulation. Three two dimensional arrays were created to give a linear output for each of the axes. The array for the x component (Figure 4-1) applied a 1:1 ratio when the joystick was moved along the x-axis. As the joystick deviated from the x-axis the ratio dropped proportionately the further the joystick was away from the x-axis. The same applied for the y-axis set-up (Figure 4-2) but rotated through 90°. By doing this, the x and y-axes would work but not together. If the joystick were pushed evenly into the x and y-axes simultaneously then neither of the two would move. This allowed for the third z-axis. The z-axis set-up (Figure 4-3) was designed to fill the gaps between

the x and y-axes. As there were four dead bands with the x and y-axis, four peaks were made for the z-axis.

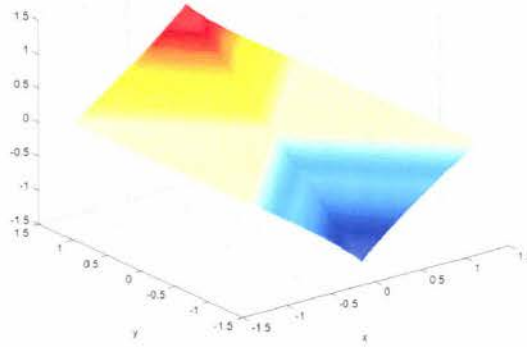

Figure 4-1. X-axis look-up array

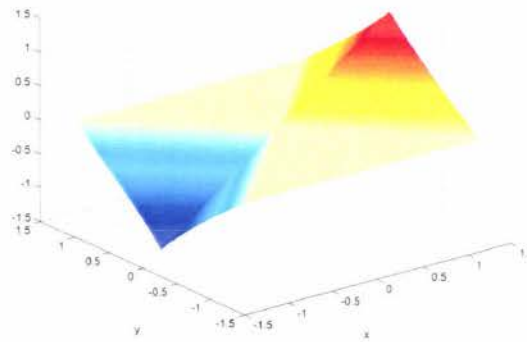

Figure 4-2. Y-axis look-up array

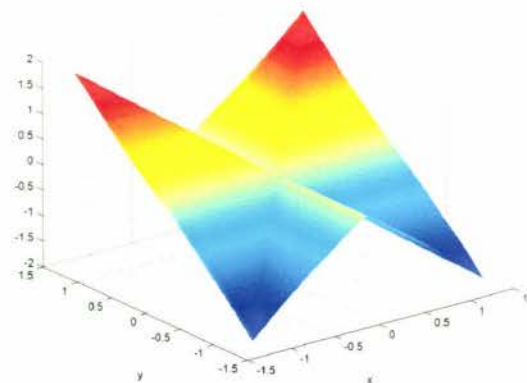

Figure 4-3. Z-axis look-up array

The three outputs from the arrays were used to drive a three dimensional model of the Hydra Trim without the wrist. The model (Figure 4-4) consisted of a wire frame that had similar

geometry to the full scale Hydra Trim. The vertical centre post could slew left and right and was controlled by the x-axis output. The boom was connected to the top of the centre post, which could lift up and down and was controlled by the y-axis output. The dipper was attached to the end of the boom and could be extended or retracted from the centre post and was controlled by the z-axis output. The model worked in real time and allowed for the operator to receive visual feedback on the position of the Hydra Trim (Figure 4-5).

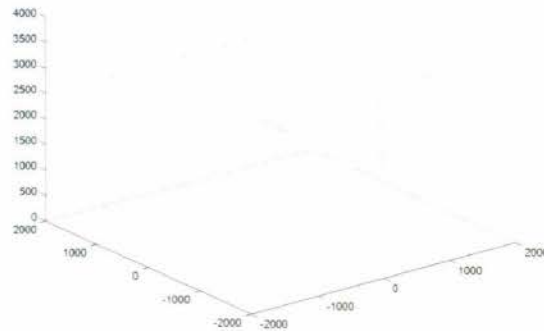

Figure 4-4. The Hydra Trim model in its starting position

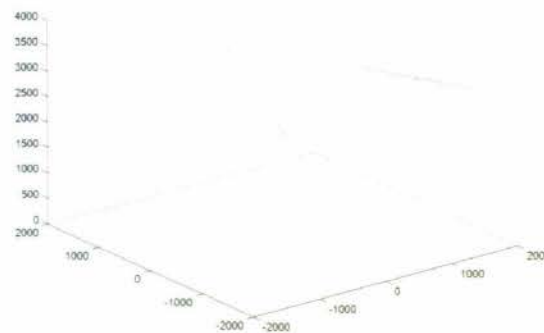

Figure 4-5. The Hydra Trim model after being moved

4.2.1.2 Conclusions

After testing the system using several different people it was concluded that this system was very hard to get use to. It did not feel like second nature. Although it was possible to move all of the limbs on the Hydra Trim model it was extremely hard to make the Hydra Trim travel to a desired position quickly and efficiently.

4.2.2 Standard Three Axis Joystick

By using a three-axis joystick the problems encountered with the previous system were overcome. But there was still the problem of only having three axes. Even by holding down a function button to switch to three other operations the Hydra Trim can still not be operated efficiently.

4.2.3 Miniature Model Joystick

By developing a miniature joystick that modelled the joint geometry of the Hydra Trim it would be possible to control every action simultaneously and independently of each other. Firstly a purpose built joystick for the Hydra Trim application was considered. This concept was withdrawn, as a purpose built joystick would only be useful for the Hydra Trim and nothing else. Flexibility was an issue that was considered when designing the joystick. If a good system could be developed for the Hydra Trim then it could also be used for other manipulators. It was decided that it would be better to develop individual joystick modules (Figure 4-6). For detailed drawings of the miniature model joystick design, see Appendix 4.

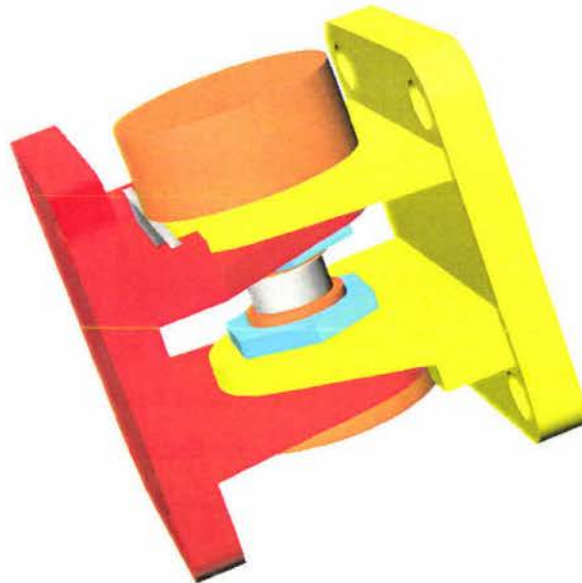

Figure 4-6. Assembled Joystick Module

The joystick module consists of two separate halves that are the same. The two halves being rotated so that they can be mated together. The springs are then inserted allowing the module to return to centre unaided. The potentiometer and the drive knob are then inserted. The retainer nuts are threaded onto the potentiometer and the knob to hold the module together. An exploded view of the module details the respective parts (Figure 4-7).

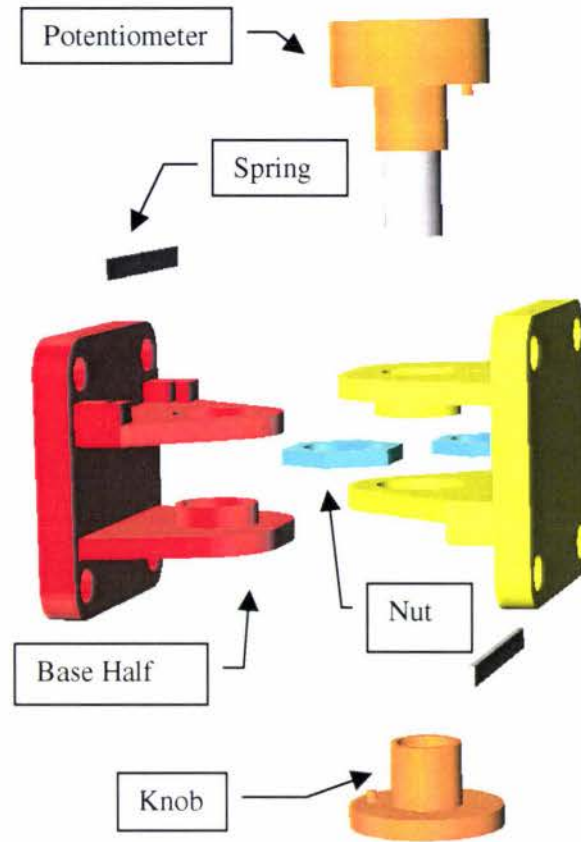

Figure 4-7. Exploded View of Module

The individual modules had the ability to rotate 20° from the centre position in either direction, which is the same as most industrial joysticks. The joystick was fitted with a high-quality plastic-film-potentiometer, which was used for measuring the joystick angle. By developing symmetric individual modules they can then be assembled in any direction so that the axis of the module can be in the same orientation as the pivot that it is controlling. Once the joystick is built to resemble the manipulator arm (Figure 4-8 & Figure 4-9), holding the end of the joystick and moving it in the desired direction controls the arm. The manipulator arm will follow and the speed of the actions would be controlled by the displacement of the joystick. The base of the joystick is mounted to the chair used by the operator. Although it is not shown the unit is housed in a padded box that replaces the armrest. This allows the operator to rest their arm and control the unit with their wrist.

By making the base half of the module the same, only one part needs to be made thus reducing the complexity of the design. The springs used are a thin piece of spring steel that is fitted into the module and deflects the same way regardless of rotational direction of the module with its rest point at the centre, thus providing a sound means of centring the joystick. The spring slides on the off round edge of the module, acting like a cam lobe.

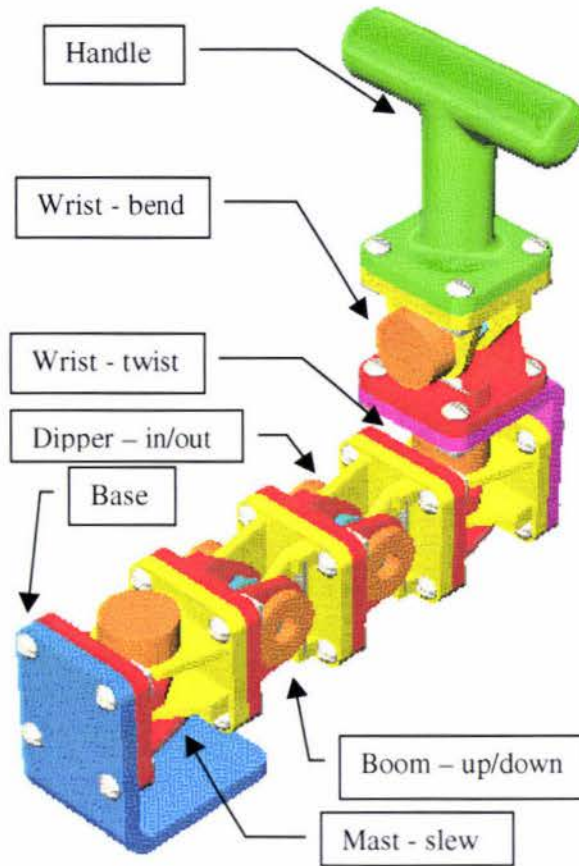

Figure 4-8. Assembled Joystick, isometric view

The base half is made of a high density plastic and is produced in an injection moulder allowing mass production, which will ultimately reduce the cost of each unit.



Figure 4-9. Assembled Joystick, front view

5 HYDRAULIC VALVES

The Hydra Trim is operated entirely by hydraulic power. This section deals with the choice of valves to be used for the Hydra Trim.

5.1 Requirements

The requirement of the valves was to provide hydraulic fluid flow proportional to the movement of the joystick. To maintain cleanliness there was to be no hydraulic oil piped into the cab of the tractor, therefore manual valves placed in the cab were not an option. Manual valves with cable operated extensions were considered, but as each individual operation requires a separate lever in the cab then up to eight levers would be required in the cab which would be difficult for the operator to control efficiently. The only option left was to use electronic proportional valves. By using these no hydraulic oil will enter the cab and as discussed in the joystick section all the functions can be put on one joystick.

5.2 Available Systems

To consider what valve system to use, several types of valves were investigated before a choice could be made. The majority of the following information was found after consultation with both Hydraulic Specialities Ltd [13] and Global Fluid Power Ltd [14]. The following is a summary of some of the valves and options investigated.

5.2.1 Danfoss

Danfoss [15] produce a valve series called the PVG 32. The PVG 32 can be used as either a manual or electronically controlled valve (Figure 5-1). When the valve is to be used as an electronic valve an additional component to the valve needs to be bolted to the valve block on the opposite end to the manual lever.

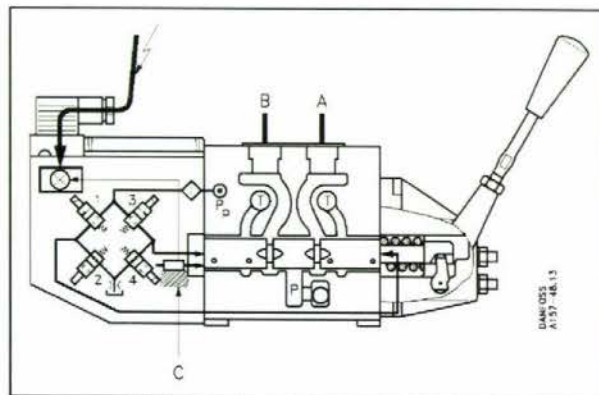

Figure 5-1. Danfoss electronic proportional valve

Opening and closing the four solenoid valves labelled 1 through 4 controls the position of the main spool valve. Two separate control systems are used for the two models of valve. The PVEM model, which is recommended for simple proportional control and where reaction and hysteresis are not crucial, uses bang on – off modulation. The PVEH model, which is recommended for fast system reaction, low hysteresis and fine regulation, uses Pulse Width Modulation (PWM). To move the spool to the left, solenoids 1 and 2 are energised allowing the pressure from P_p to flow to the right side of the spool valve. The pressure difference between the two sides causes the spool to move to the left. The position of the spool is registered by the linear variable differential transformer (LVDT) labelled “C” in Figure 5-1. The LVDT allows for closed loop control, as the position of the spool can be monitored and be adjusted to the set point where the operator has set the joystick.

5.2.2 Moog

Moog [16] produce a valve series called the 30 series flow control servo valve. The valve is purely electronically controlled. The valve assembly consists of a torque motor, hydraulic amplifier and a spool valve.

5.2.2.1 Torque Motor

The torque motor consists of an iron armature (Figure 5-2) that is housed within a charged permanent magnet (Figure 5-3).

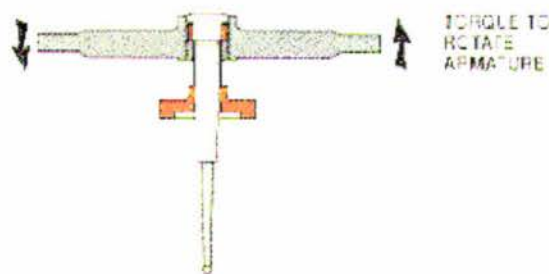

Figure 5-2. Armature

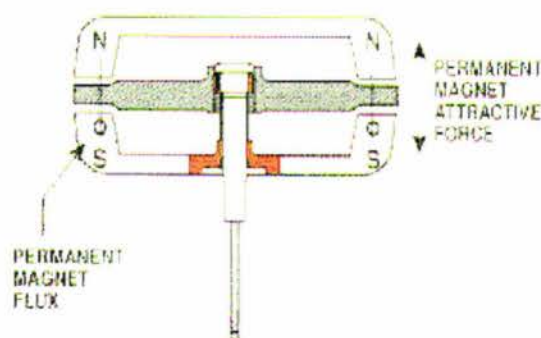

Figure 5-3. Torque motor

A coil is wound around the armature and when excited causes the armature to rotate and exert a torque that is proportional to the current fed in (Figure 5-4).

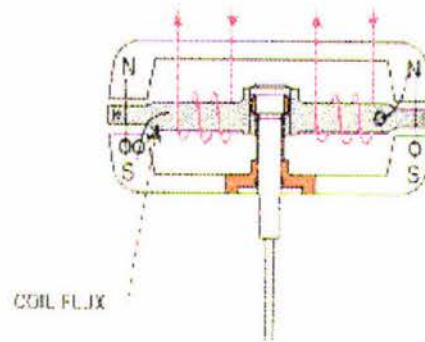

Figure 5-4. Torque motor – Current applied

5.2.2.2 Hydraulic Amplifier

The flapper that is rigidly connected to the armature and supported by a thin-wall flexure sleeve operates the hydraulic amplifier (Figure 5-5). Hydraulic fluid continuously flows from P_S , through both inlet orifices past the nozzles and into the flapper chamber. The fluid then returns to the tank via the drain orifice then to return R. The rocking motion of the flapper throttles flow through one nozzle to the other. This diverts flow to either port A or B. If both A or B are blocked then pressure builds up.

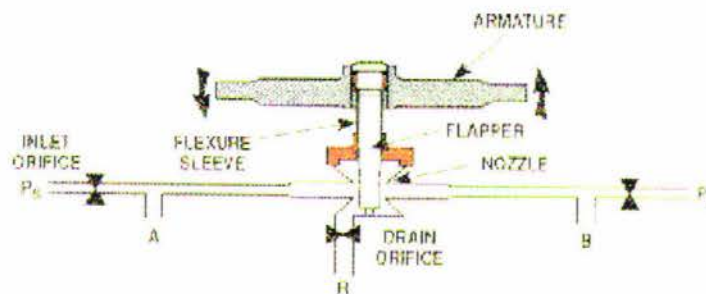

Figure 5-5. Hydraulic Amplifier

5.2.2.3 Spool Valve

The spool valve (Figure 5-6) is similar to a normal spool except the middle of the spool has a groove to allow the connection of the feedback spring. When the spool is in the null position both P_S and R are blocked and no fluid flows either to or from the control ports C1 and C2. When hydraulic pressure is applied at B the spool moves to the left causing fluid to flow from P_S to C2 and from C1 to R.

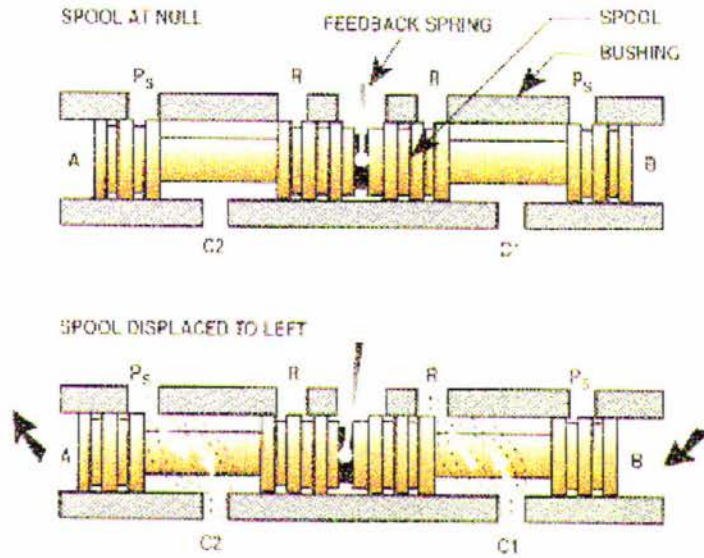

Figure 5-6. The spool Valve

5.2.2.4 Operation

With the torque motor, hydraulic amplifier and the spool valve combined the servo valve is conceived. When the current is applied to the torque motor (Figure 5-7) the torque causes the armature and thus the flapper to rotate. As the flapper moves the hydraulic amplifier creates a differential pressure that causes the spool to move allowing oil to flow through the spool. As the spool moves, tension on the feedback spring resists the torque of the armature.

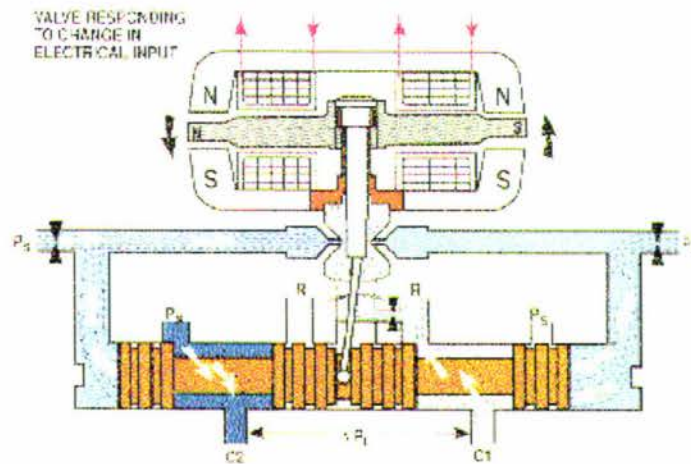

Figure 5-7. Servo Valve – Current applied

When the torque is equalled the flapper returns to the centre position so the pressure differential drops to zero and the spool stops moving (Figure 5-8). When the current is stopped the feedback spring causes the flapper to move in the other direction thus applying pressure to the other side of the spool causing it to move back to the centre position.

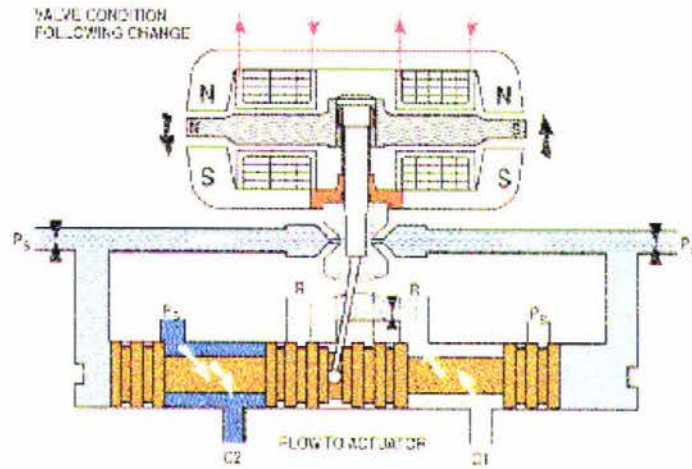

Figure 5-8. Servo Valve – Equilibrium

5.2.3 Apitech

Apitech [17] in conjunction with Fluid Power Systems [18] produce the Pulsar™ VPL series of valves. The valves can be operated either manually or electronically. When controlled electronically the main spool is operated by a pilot pressure system (Figure 5-9). The pilot pressure is controlled by pressure that is feed into the variable orifice from the pump and a fixed orifice that exhausts the oil to the tank

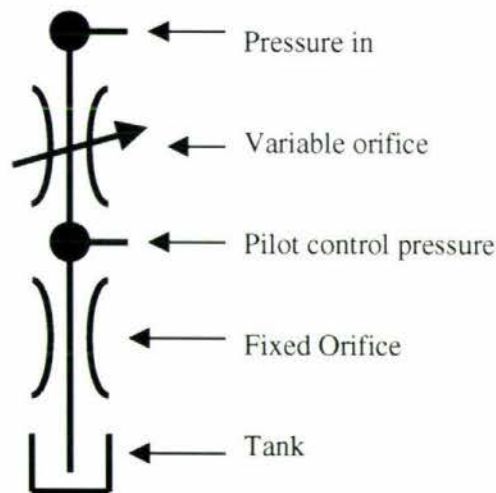

Figure 5-9. Pilot system

If the variable orifice is open more than the fixed orifice then the pilot pressure increases. The opposite applies if the variable orifice is smaller. One of the great advantages of this system is that the acceleration and deceleration of the spool and ultimately the hydraulic fluid controlled. This is achieved as it takes a short amount of time for the pilot pressure to build or drop after the variable orifice has been opened or closed respectively. This feature makes it great for high

inertia loads and situations where shock loading needs to be avoided. Each spool valve has an individual pilot system to control each end of the spool. When there is a difference in pressure the spool will move until the opposing force applied by the centring spring is equalled. This method allows for very accurate control of the spool without the need of measurement feedback to realise where the spool is positioned. The variable orifice is controlled by a solenoid that is feed with a Pulse Width Modulated (PWM) signal. The relationship between the modulation ratio and the flow output of the spool valve is displayed in Figure 5-10.

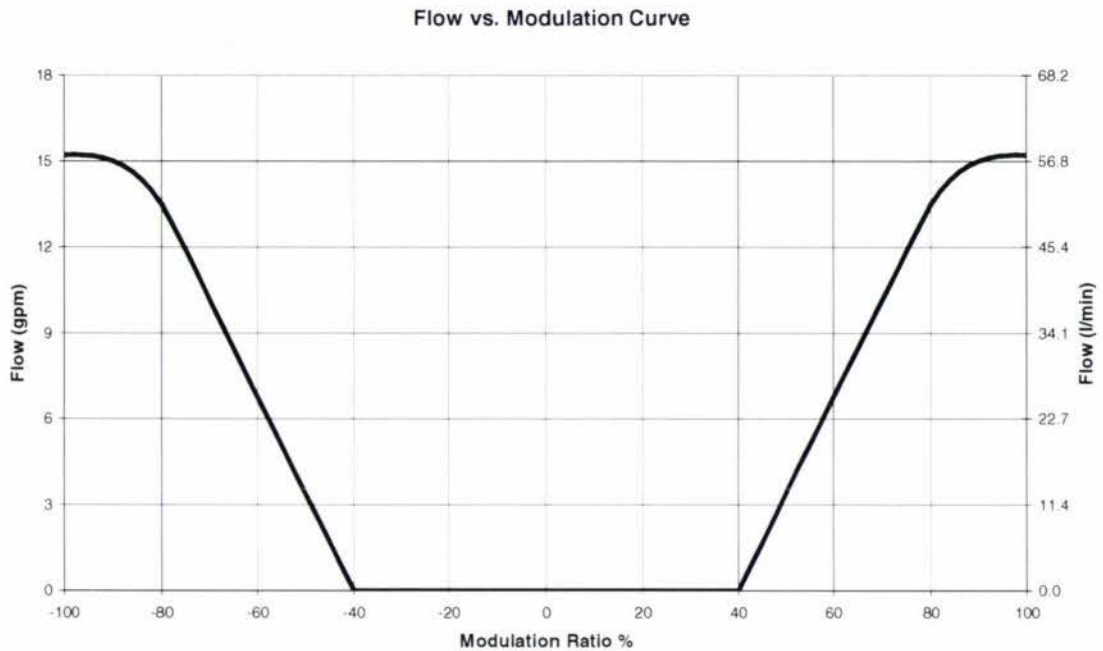

Figure 5-10. Flow & modulation relationship

From the graph it can be noted that the valve has very good linearity. By altering the deadband and the maximum modulation on the controller, the valves can be adjusted for most situations.

5.2.4 Conclusions

The reason only three valve types were discussed for this comparison is because most other valves on the market fell into one of the three types. After researching the three options it was decided that the Apitech system would be used for the project. This conclusion was reached after considering the pros and cons for each system.

5.2.4.1 Danfoss

As the Danfoss system has several different models of the same valve, to obtain accurate control of the valve the top of the range PVEH model is required. Being the top model the unit is quite expensive. As the system uses electronic closed loop control it is very accurate but the feedback

introduces added complexity to both the valve and the electronics, which can cause future reliability problems.

5.2.4.2 Moog

The Moog servo system is the best system for very precise control, but there is a price tag to suit. The speed and precision of these valves is really designed for entertainment simulators found at theme parks, which require that exact control. This level of control is not really applicable for the Hydra Trim.

5.2.4.3 Apitech

The Apitech system is very simple, as there is no electronic feedback. The feedback is applied by the return spring. As the system is based on a mechanical valve they are very reliable. The PWM provides very precise control approaching that of a servo valve. After considering all the above features the Apitech is definitely the best option.

6 CONTROLLER

The controller is the link between the joystick and the hydraulic valves. There are two options available for the controller. These are to use the standard off the shelf controller that comes with the valve, or to design a controller. The Hydra Trim has up to eight individual operations. The controller that comes with the Apitech valves can only control three proportional operations. Considering the purchase price of the controller units and that three are required, then the option of producing a controller is viable. Two options were considered for producing a controller. These options were individual analogue units or a micro-controller unit that controls multiple actions. Each individual spool valve has two Pulsars™ and therefore requires two control signals. The individual Pulsars™ are switched by one solid state MOSFET (Metal Oxide Silicon Field Effect Transistor).

6.1 Analogue Controller

The concept for the analogue controller is to accept a voltage input from the potentiometer on the joystick module, then send a PWM signal to either of the two Pulsars™. This was done using a voltage follower to buffer the incoming voltage. Using a non-inverting and an inverting amplifier the voltage is split into two individually amplified signals of opposite polarity. The individual amplification allows for the maximum output of each action to be set. A triangular waveform is generated separately. This waveform has a frequency of 33 Hz to match the driving frequency of the Pulsars™. Using an integrator looped with a Schmidt trigger can easily generate this. The output of the Schmidt trigger is fed back into the integrator. This forms an astable vibrator that can produce either a square or triangular wave output. The triangular waveform is passed through a summing amplifier with a constant voltage. This allows for the set-up of the deadband of the system. The two opposite voltages are fed into two separate comparators with the triangular waveform. When the input voltage exceeds the voltage of the triangular waveform the MOSFET is turned on, which in turn activates the Pulsar™. Figure 6-1 shows the waveforms and their relative timing. The first is the input voltage from the joystick, the second is the triangular waveform with a frequency of 33 Hz, the third is the control signal for the up Pulsar™ and the fourth is the control signal for the down Pulsar™. In the third and fourth plots, 0 denotes the Pulsar™ is off, whereas 1 denotes the Pulsar™ is switched on.

This is a very simple system that can control an individual spool valve from one incoming voltage signal. The operator via visual feedback controls the positioning of the system. This scenario operates as velocity control. By inserting a PI (Proportional Integral) controller after

the voltage follower and adding a feedback potentiometer to the action that is being controlled, then the controller can operate as a position control system. Although position control can be applied, other additions including path following and collision avoidance would be difficult to implement. To do this efficiently a micro-controller is required.

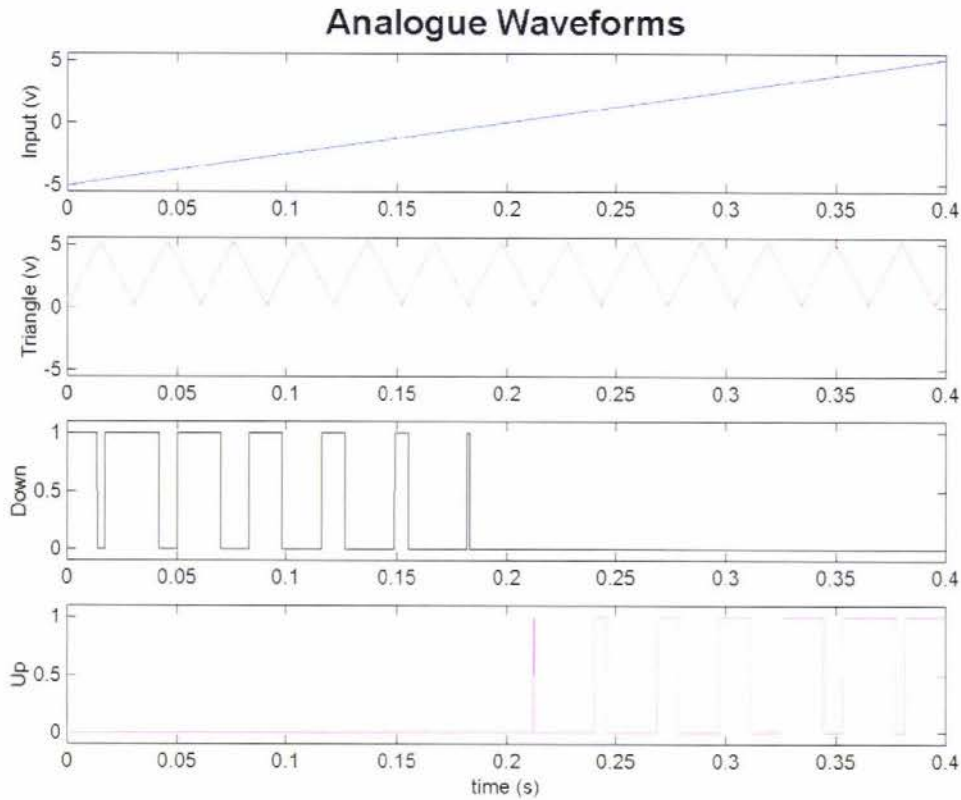

Figure 6-1. Analogue Controller signals

6.2 Micro-controller

The concept for the micro-controller is the same as that of the analogue controller. The output from the joystick is an analogue voltage that needs to be digitised so the micro-controller can work with the data. This is done with an analogue to digital converter. This accepts the analogue voltage and outputs a digital number that is proportional to the input voltage. Once the position of the joystick is converted to a digital number the micro-controller then knows where the joystick is set. It then activates the appropriate Pulsar™ for the desired length of time to achieve the correct PWM signal. The Pulsar™ operation is done at 33 Hz, which complies with its frequency.

7 CONCLUSIONS

7.1 Wrist

The requirements of the wrist were to be able to hold and move a mass of 10 kg displaced 400 mm from the axis of rotation of the wrist and obtain a greater range of movement than the two prototype designs.

Hydraulics was chosen as the power source for the wrist. The reasoning behind this choice is that most tractors do not have air compressors, which omits pneumatics. Electric motors were considered but lack the speed and power of hydraulics, so were also disregarded.

The prototypes suffered from binding problems. This caused the whole design to be rethought. The design submitted by Pivot Engineering Ltd, which uses two conventional hydraulic rams that slide on two counter rotating helices, was investigated. This led to further advancement that resulted in the development of a hydraulic rotator. Off the shelf rotators were considered for use on the wrist. These were later discarded due to their operating recommendations that did not comply with the wrist requirements and its operating environment. The hydraulic rotator consists of two doughnut shaped pistons that push in either direction on a ball screw. The ball screw nut is held so that it cannot rotate and the ball screw shaft is held so that it cannot move axially. The movement of the pistons causes the output shaft to rotate. To achieve the two axes of the wrist, two rotators are used. The torque and pressure limitations of the rotator unit exceed the requirements of the wrist design.

7.2 Joystick

The Hydra Trim has a total of eight functions, five main working functions, two telescopic and one hydraulic motor function. All of these functions need to be controlled efficiently by one hand. The other is required to operate the machine on which the Hydra Trim is mounted. Several options were considered. The first was to use a two-axis joystick that operated three functions with three two-dimensional lookup tables. This option was discarded because it did not have a natural feel of control. Although all the functions could be operated, the operator could not instinctively place the end of the manipulator where it was wanted. The second option of using a three-axis joystick was considered. Due to the functions on the Hydra Trim, not all could be controlled at once. The third option was to develop an individual joystick unit that operated only one function. Connecting the individual units together with the same geometry as

the actual Hydra Trim, then all the major actions could be controlled at once. This allows for a very natural feel of control for the operator. If the operator moves the joystick unit up and to the left the Hydra Trim will follow at a velocity proportional to how far the joystick was moved.

7.3 Hydraulic Valves

Three types of valve were considered for the Hydra Trim. These included the Danfoss PVG 32 series, the Moog 30 series servo valve and the Apitech Pulsar™ VPL series valve. Other brands do exist, but they all fall into one of the three categories of valve. After considering the three types of valve it was concluded that the Apitech is the best option. The Danfoss valve is quite expensive, as the top of the range valve is required to achieve the desired level of control. The Moog servo valve has the most precise control and is very fast. Cost is the main reason for disregarding the Moog valve. The Moog valve is primarily designed for entertainment simulators, which require considerable more control and speed than the Hydra Trim. Because the Apitech uses a manual valve with the addition of two Pulsars™ it is relatively cheap. The level of control from the Apitech valve is very similar to that of a servo valve.

7.4 Controller

Two controller designs were considered. These were individual analogue controllers or a single micro-controller based system. The analogue controller allows easy expansion for extra functions by adding another unit, because they are all independent of each other. The micro-controller unit operates all the functions. Because of this, expansion for extra functions requires extra inputs and outputs, which means using a larger micro-controller. The main reason for using a micro-controller instead of the analogue controller is to add intelligence to the Hydra Trim. This intelligence will allow the Hydra Trim to follow kerbs and avoid obstacles. To allow for this the Hydra Trim needs to be fitted with sensors that communicate with the micro-controller. To speed the development of the Hydra Trim the analogue controller should be used.

7.5 Cost

When considering the cost of components and labour involved, the total cost of the Hydra Trim, including control system, joystick and mounting on the vehicle will range between NZ \$30,000 and NZ \$40,000.

8 FUTURE WORK

Although the wrist has been designed, building and testing it is the only true way to discover its capabilities. Once the rotator units are built, tests should be conducted to ascertain its ability to perform to the requirements and the life expectancy. The same test rig could be used for both tests. Mounting the unit to a bench with the axis of rotation parallel to the floor will test for the ability to lift the required 10 kg placed 400 mm from the axis. Placing the weight below the unit when it is fully rotated one way allows the weight to be accelerated upwards, then over the top and decelerated as it heads towards the bottom again. This situation will also test the end stops within the unit. Automatically setting the unit to cycle continuously with a counter attached will be a good measure of the life expectancy of the unit. This kind of testing will quickly identify weaknesses within the unit. Once found the weaknesses can be redesigned allowing for further testing, and thus a stronger unit. Placing the unit so the rotational axis is vertical with the weight attached the same way will test its ability to withstand longitudinal bending moments on the shafts. After bench testing the units, assembling them into the format of the wrist and attaching them to the end of the Hydra Trim is the next step.

The joystick also needs to be built. The prototypes will need to be machined from a solid block of high-density plastic. This will allow for testing purposes. Tests should include assembling a complete unit, mounting one half to a test rig and moving the unit in either direction. An electric motor with a crank attached could be used to reciprocate the joystick back and forth for life testing. Once the testing is complete and the problems have been solved, the injection mould can be developed for production.

9 REFERENCES

- 1 Intercad (NZ) Ltd
Level 2, Telecom House, 666 Great South Road, Penrose, Auckland, PO Box 62594
<http://www.intercad.co.nz>

- 2 CADPRO Systems Ltd
PO Box 90 847, Auckland, New Zealand
<http://www.cadpro.co.nz>

- 3 CADKEY Corporation
<http://www.cadkey.com>

- 4 Pivot Engineering Ltd
11a Edmundson St, Onekawa, Napier, New Zealand

- 5 Bomford Turner Ltd an Alamo Group Company
<http://www.bomford-turner.com>

- 6 McConnel Ltd
<http://www.mcconnel.com>

- 7 Alamo Industrial Ltd
<http://www.alamo-industrial.com>

- 8 Helac Corporation
<http://www.helac.com>

- 9 HKS Dreh-Antriebe GmbH
Rotgartenstraße 16, D-63607 Wächtersbach-Aufenau

- 10 THK International Ltd
<http://www.thk.com>

- 11 Saeco Bearings & Transmission
660 Tremaine Ave Palmerston North
0-6-356 9561

- 12 The MathWorks Inc
<http://www.mathworks.com>

- 13 Hydraulic Specialties Ltd (Hyspecs)
9-11 Lady Ruby Drive, East Tamaki, Auckland, P.O. Box 58655 Greenmount

- 14 Global Fluid Power Ltd
64-66 Huia Rd Otahuhu Auckland 0-9-270 2964

- 15 Danfoss Fluid Power
<http://www.danfoss.com/Fluidpower>

- 16 Moog Inc
<http://www.moog.com>

- 17 Apitech, a unit of Applied Power Inc.
12801 West Silver Spring Road, Butler, Wisconsin 53007-1016

- 18 Fluid Power Systems, a division of Fluid Power Industries Inc
595 Schelter Road, Lincolnshire IL 60069

APPENDIX 1: COUNTER ROTATING HELIX DRAWINGS

This appendix shows detailed drawings relating to section 3.3.1

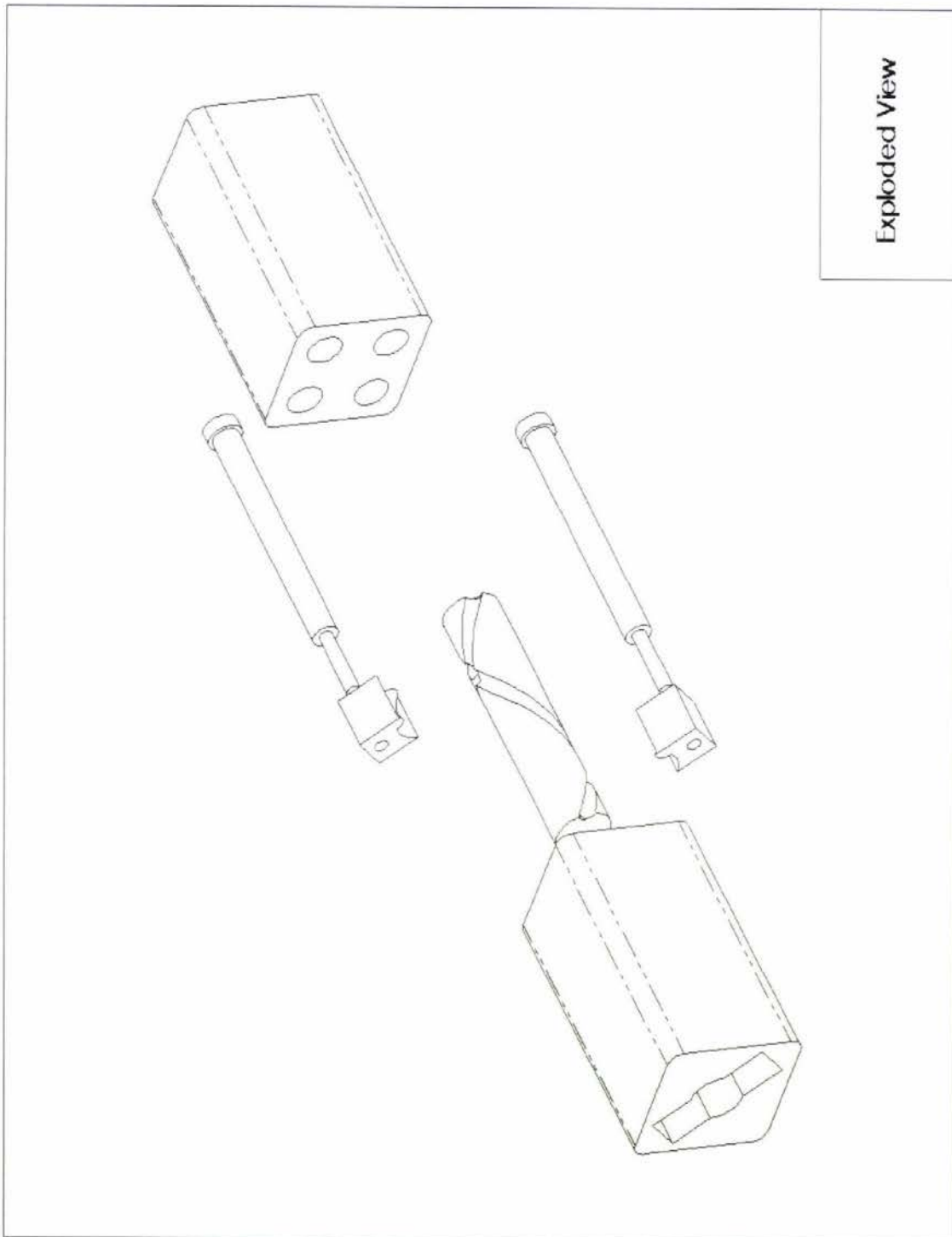

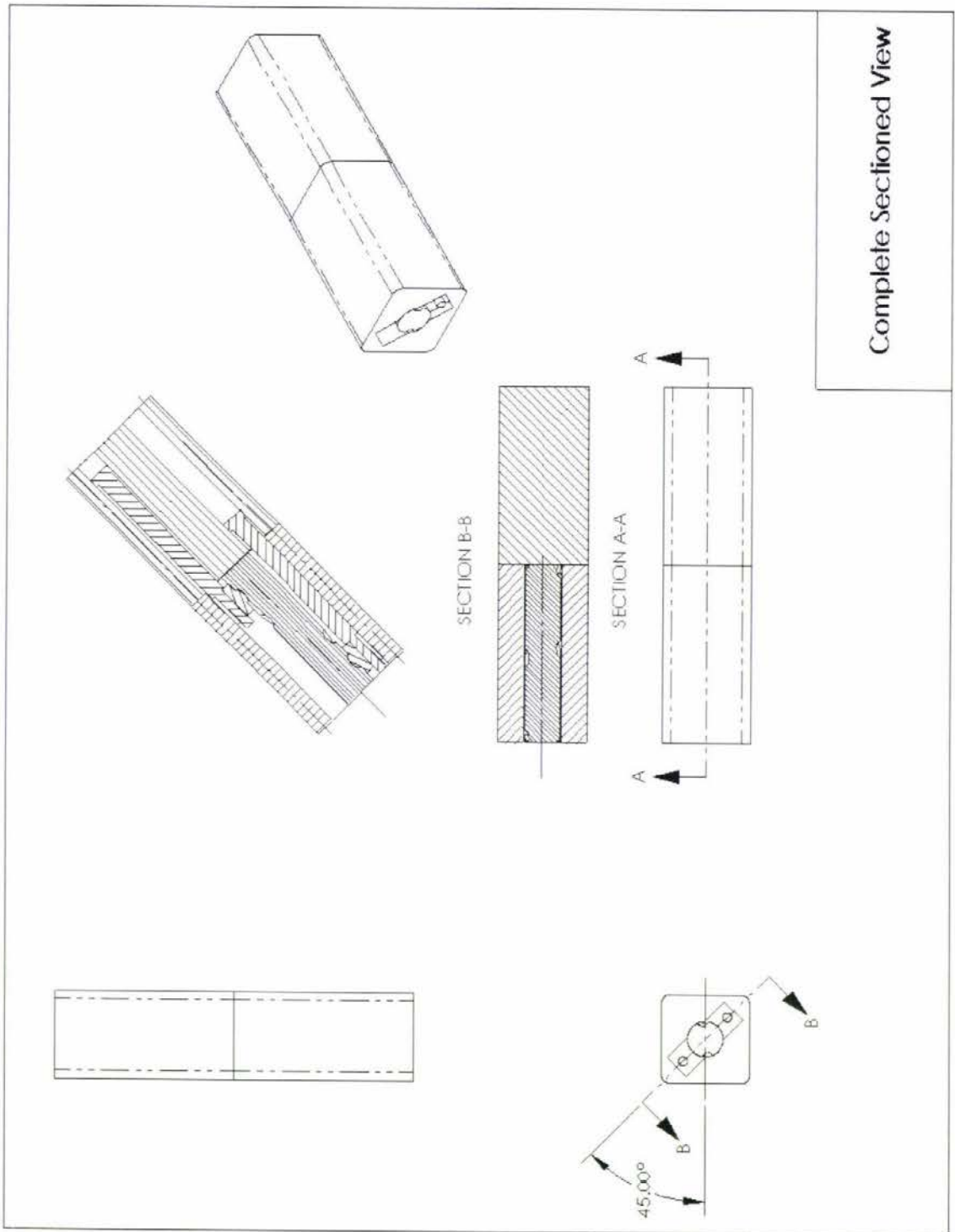

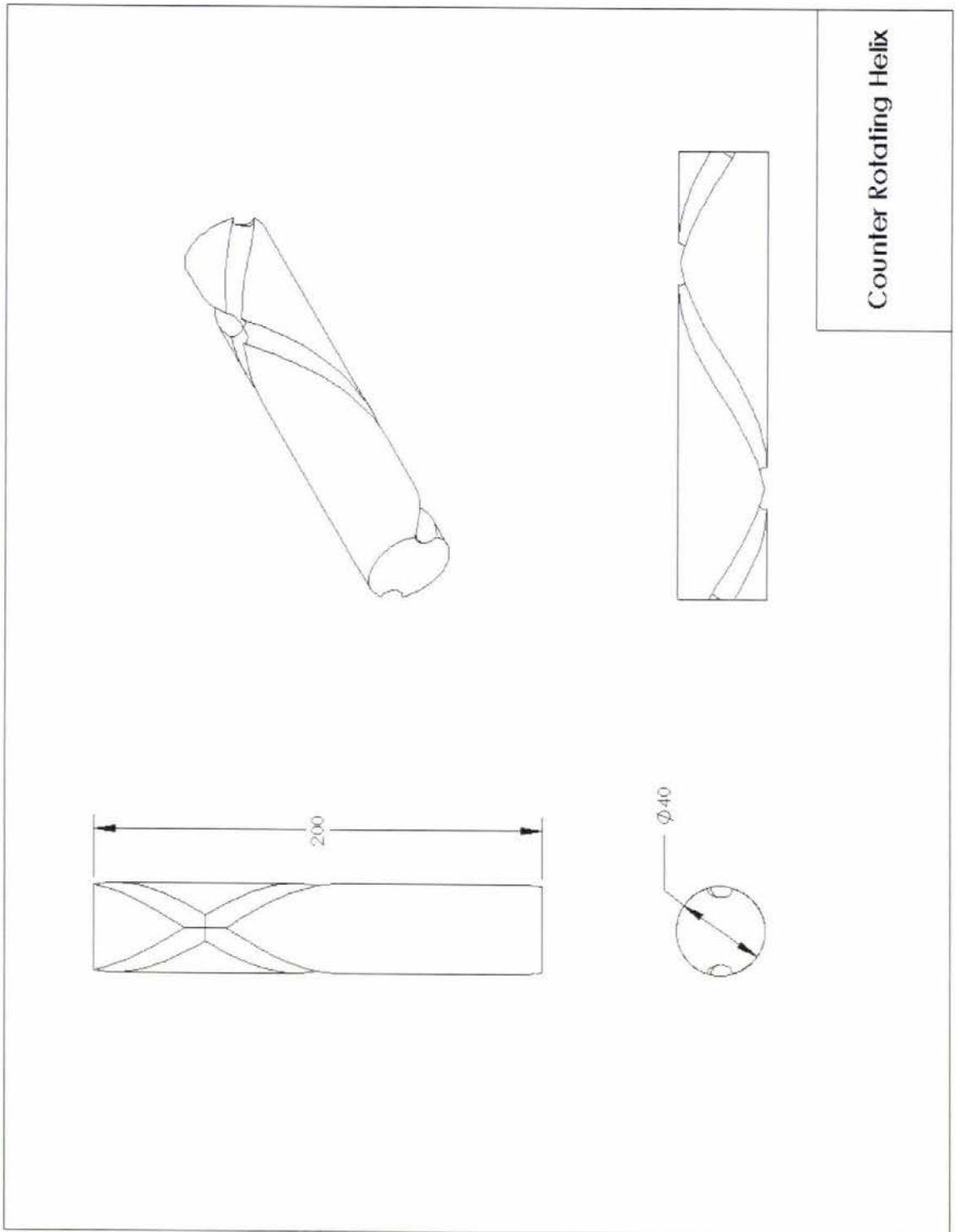

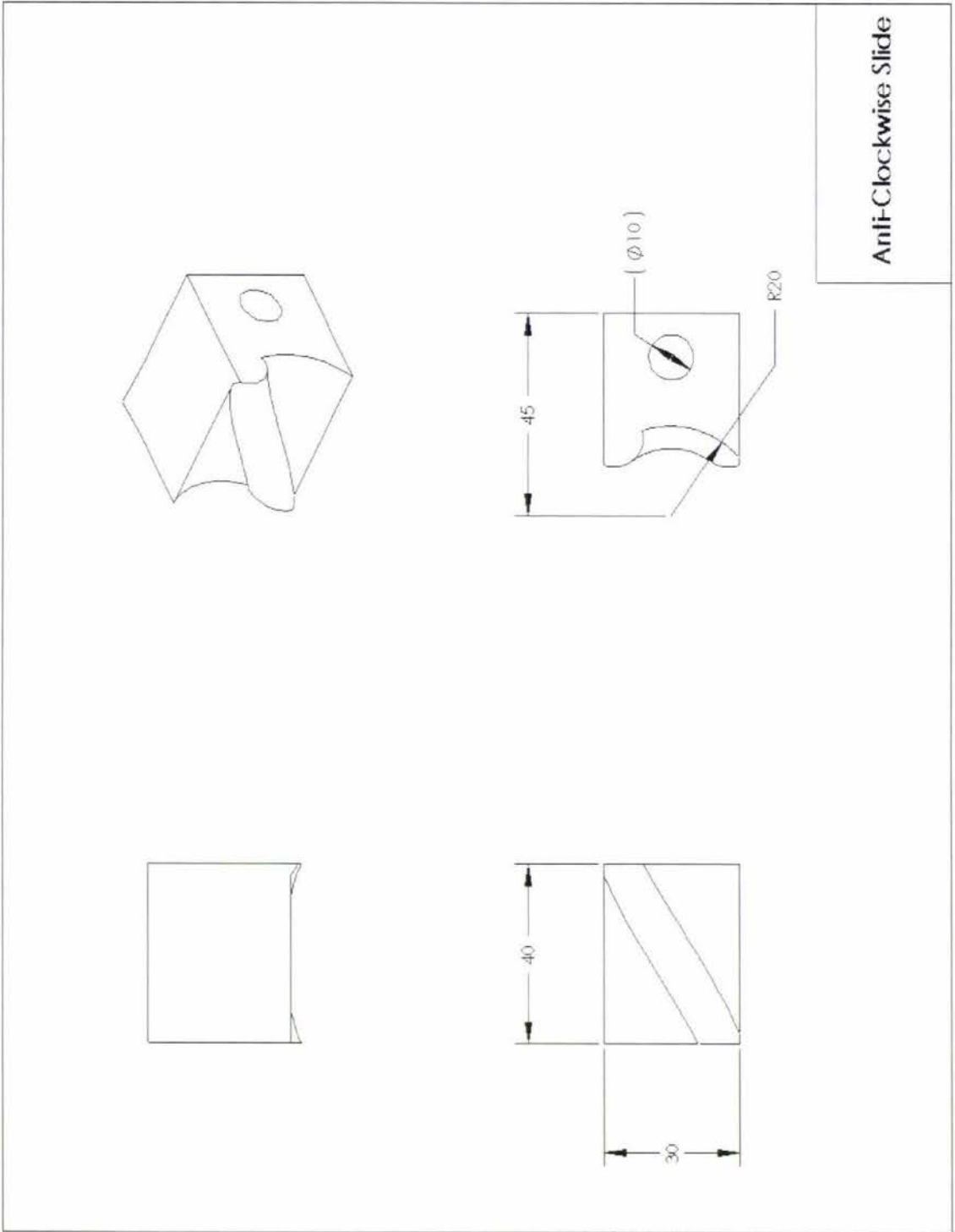

Anti-Clockwise Slide

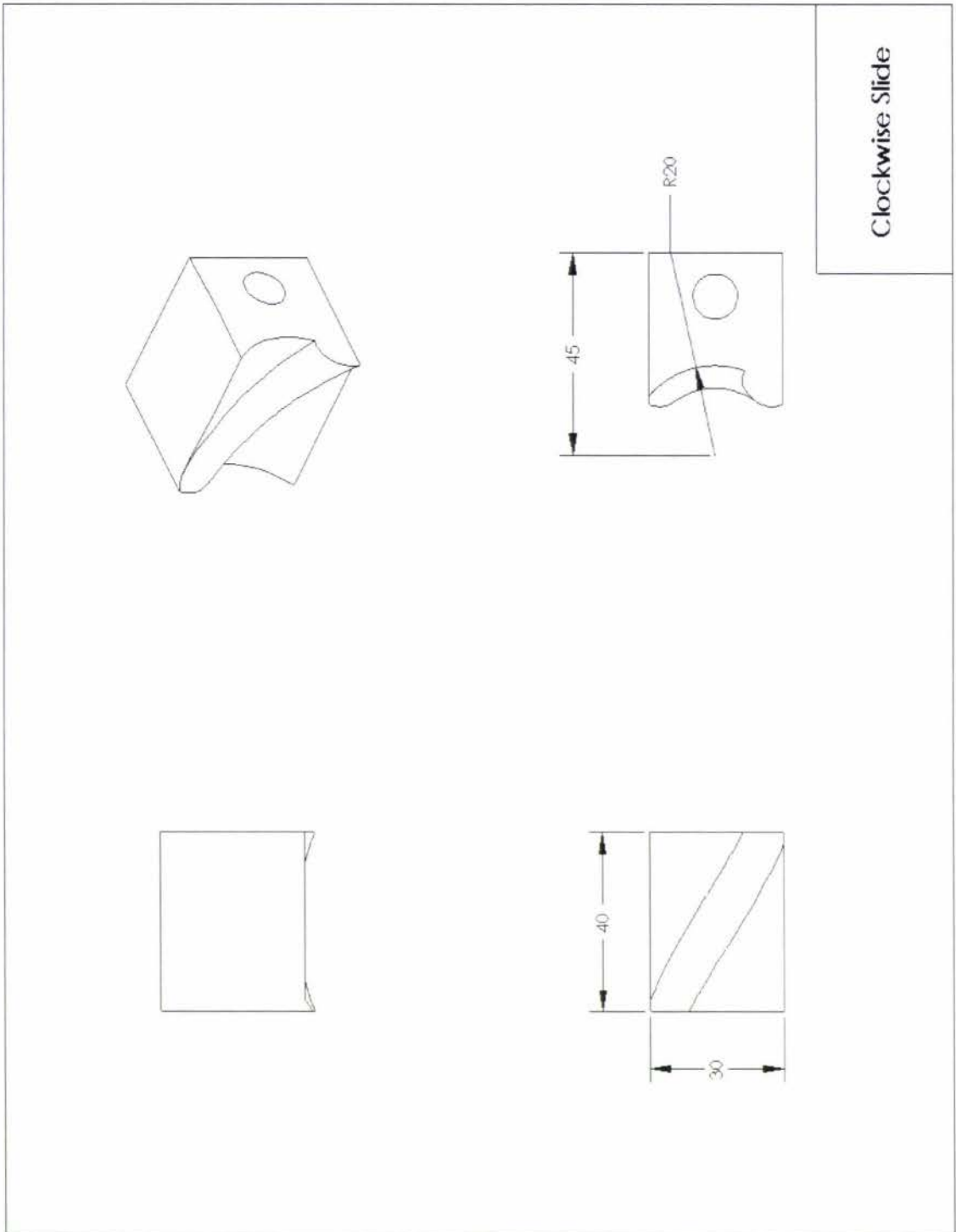

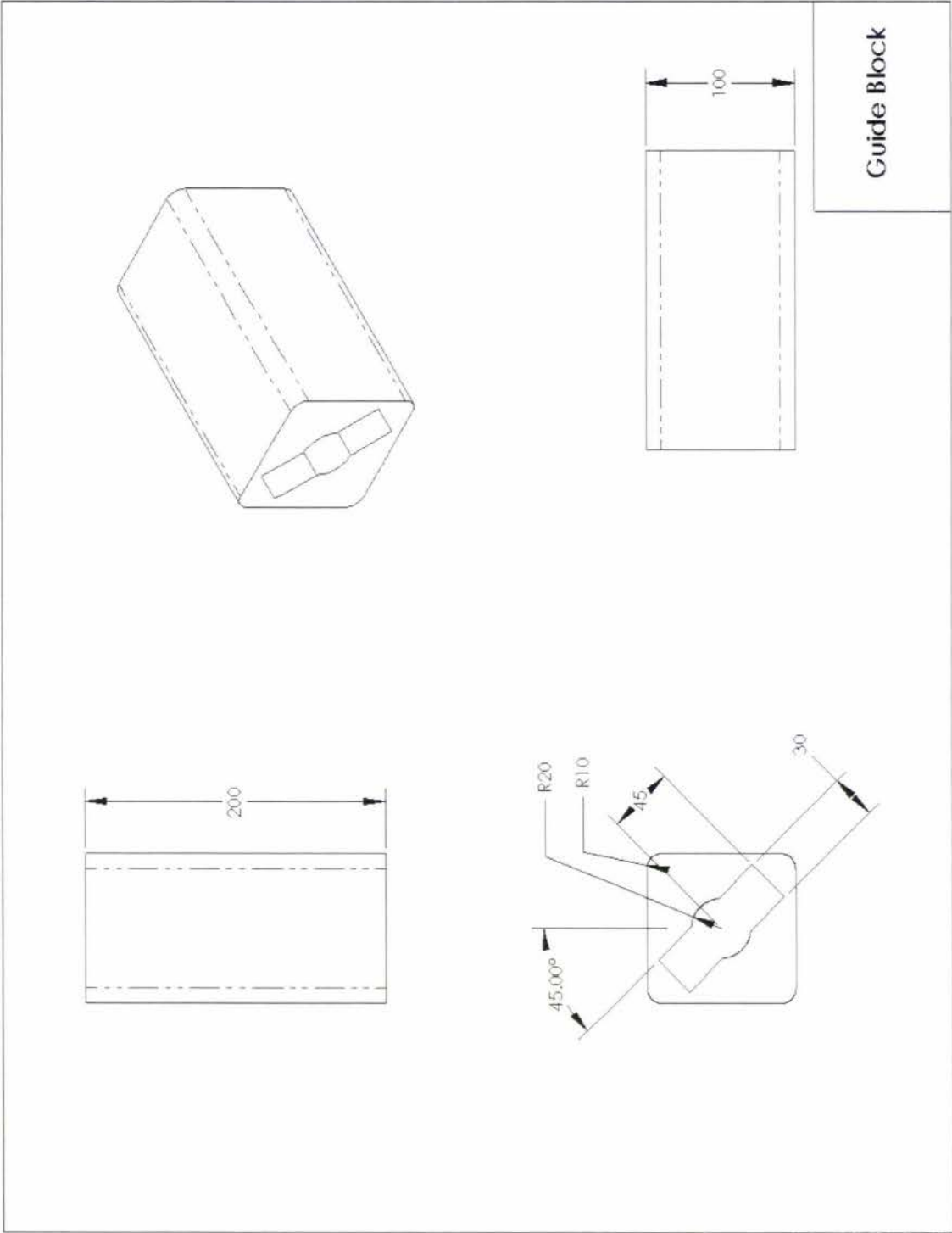

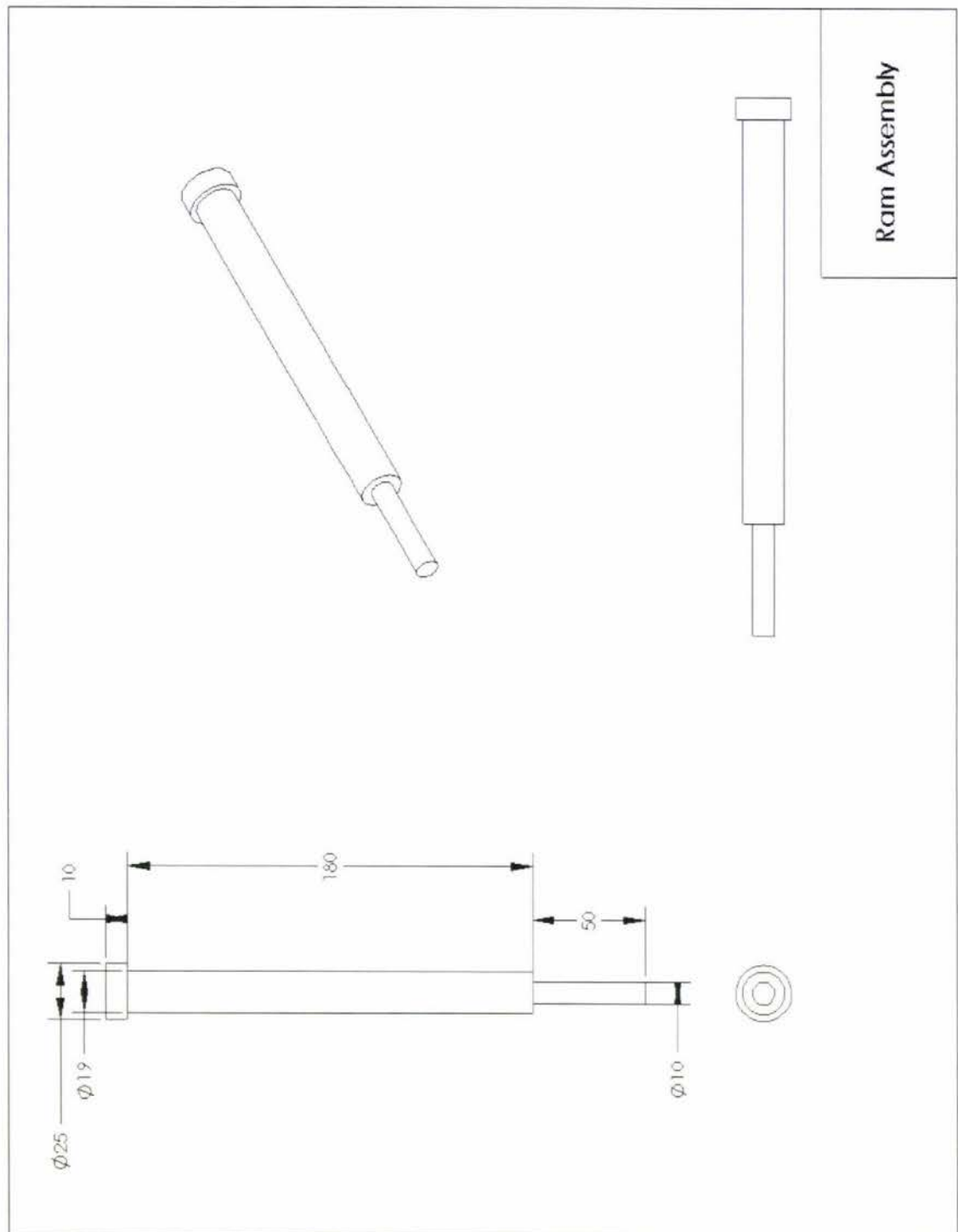

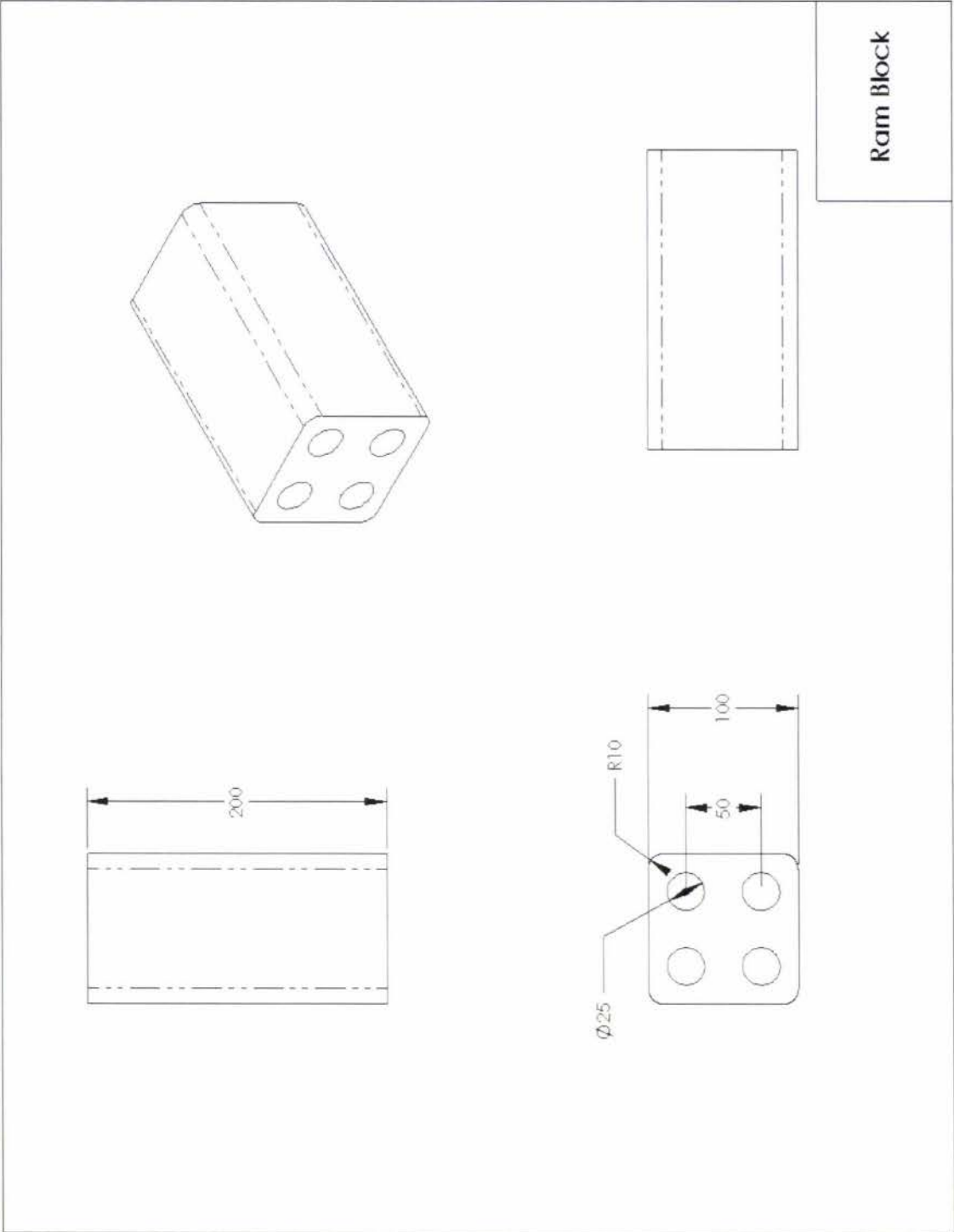

APPENDIX 2: ROTATOR UNIT DRAWINGS

This appendix shows detailed drawings relating to section 3.3.2.3

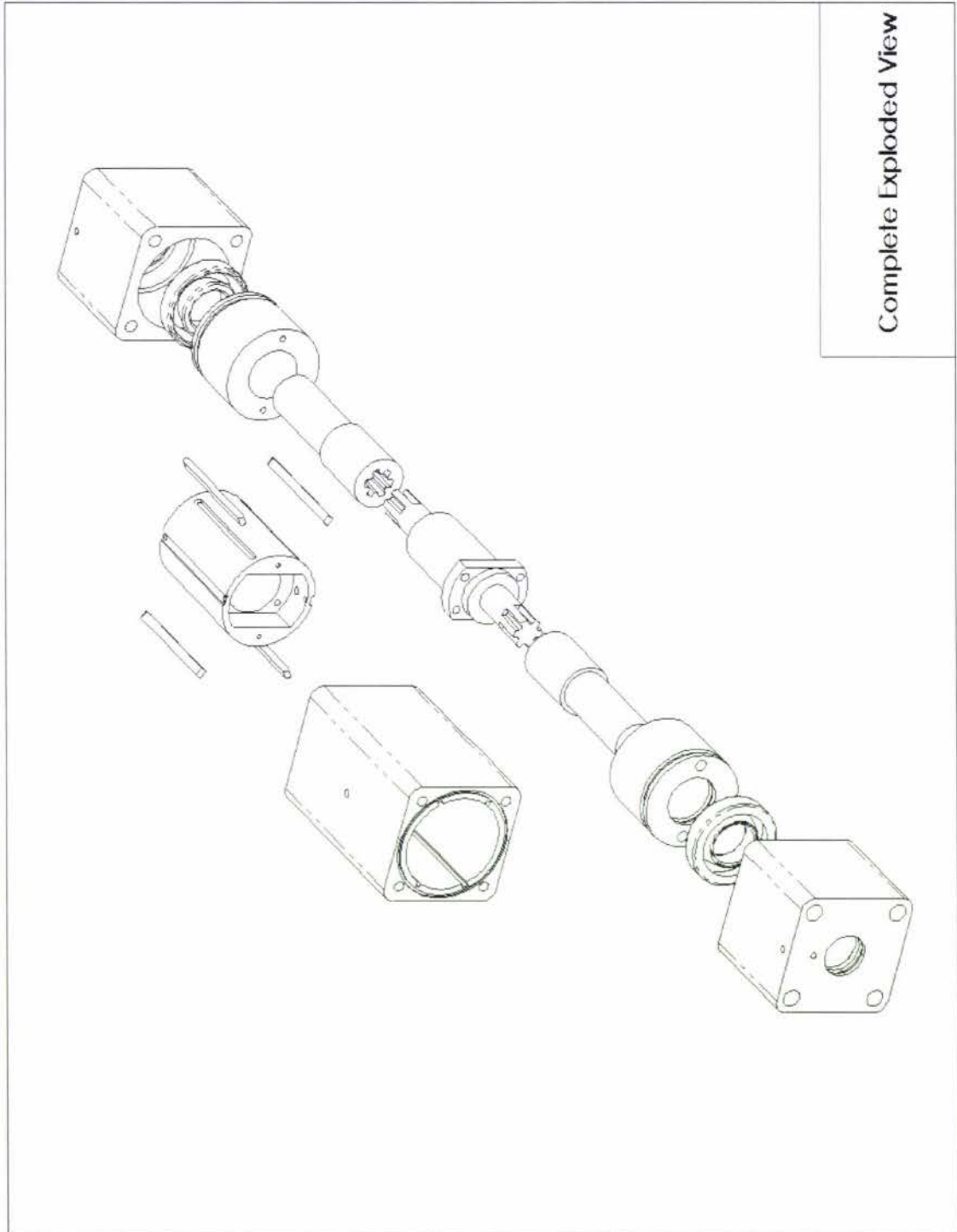

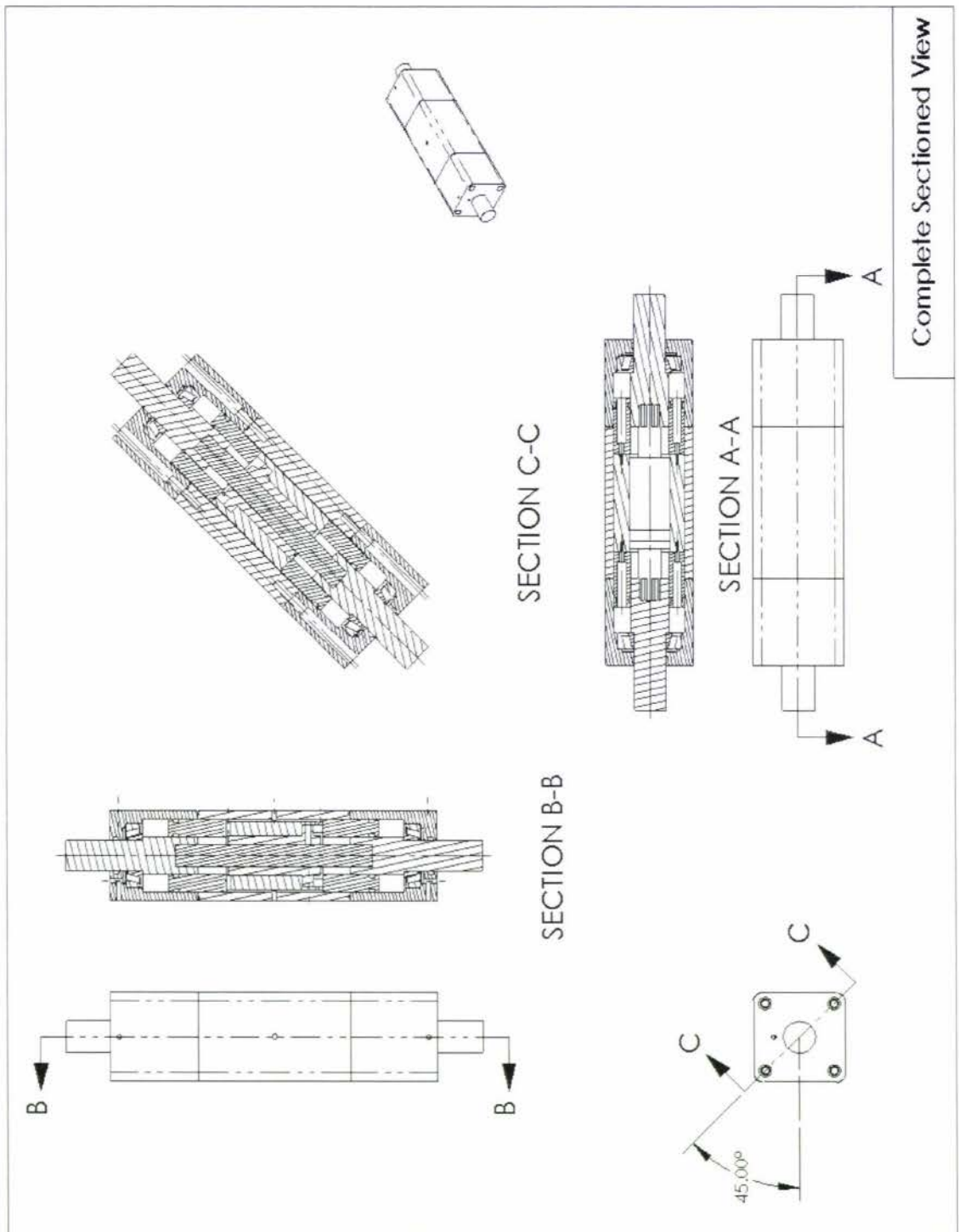

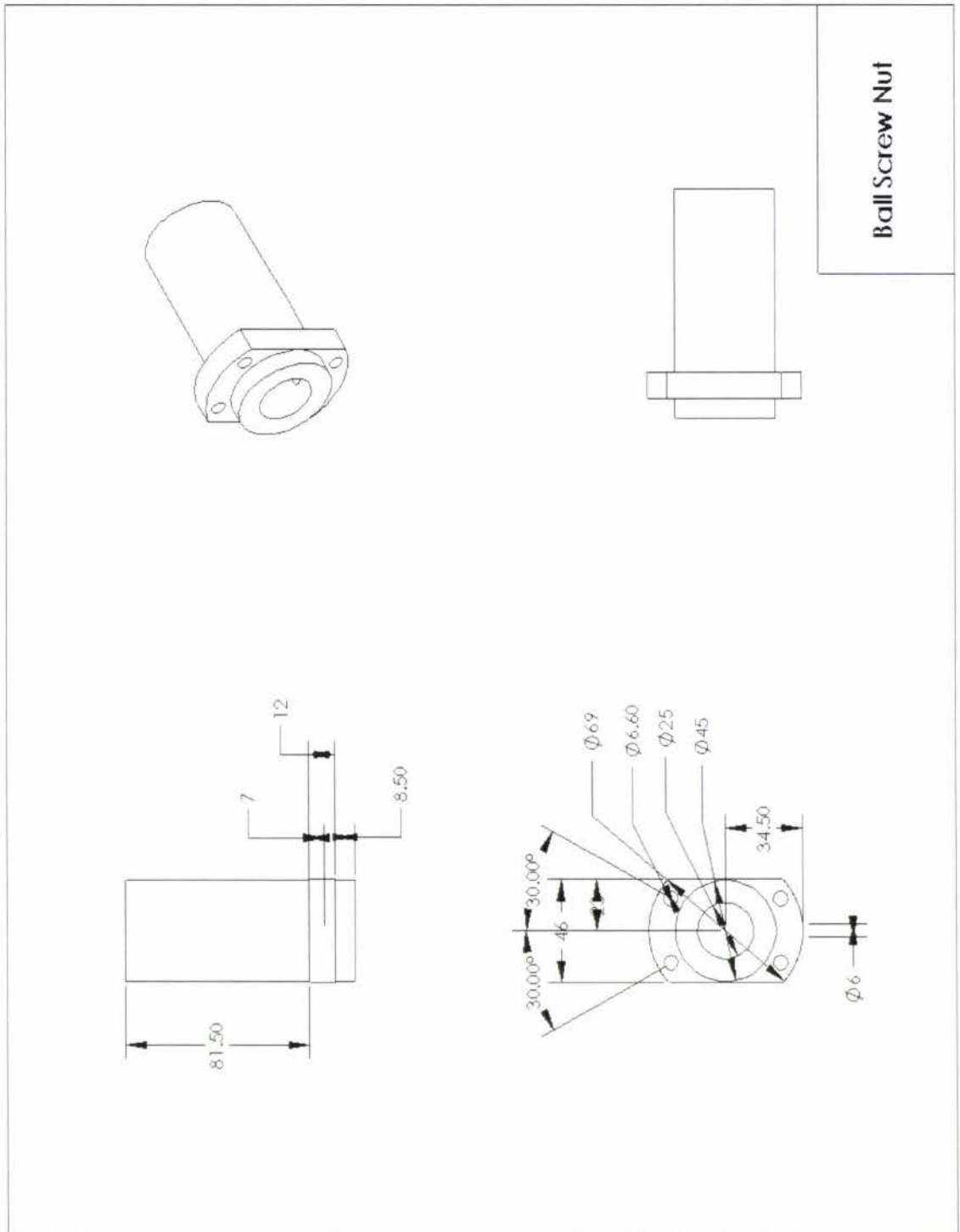

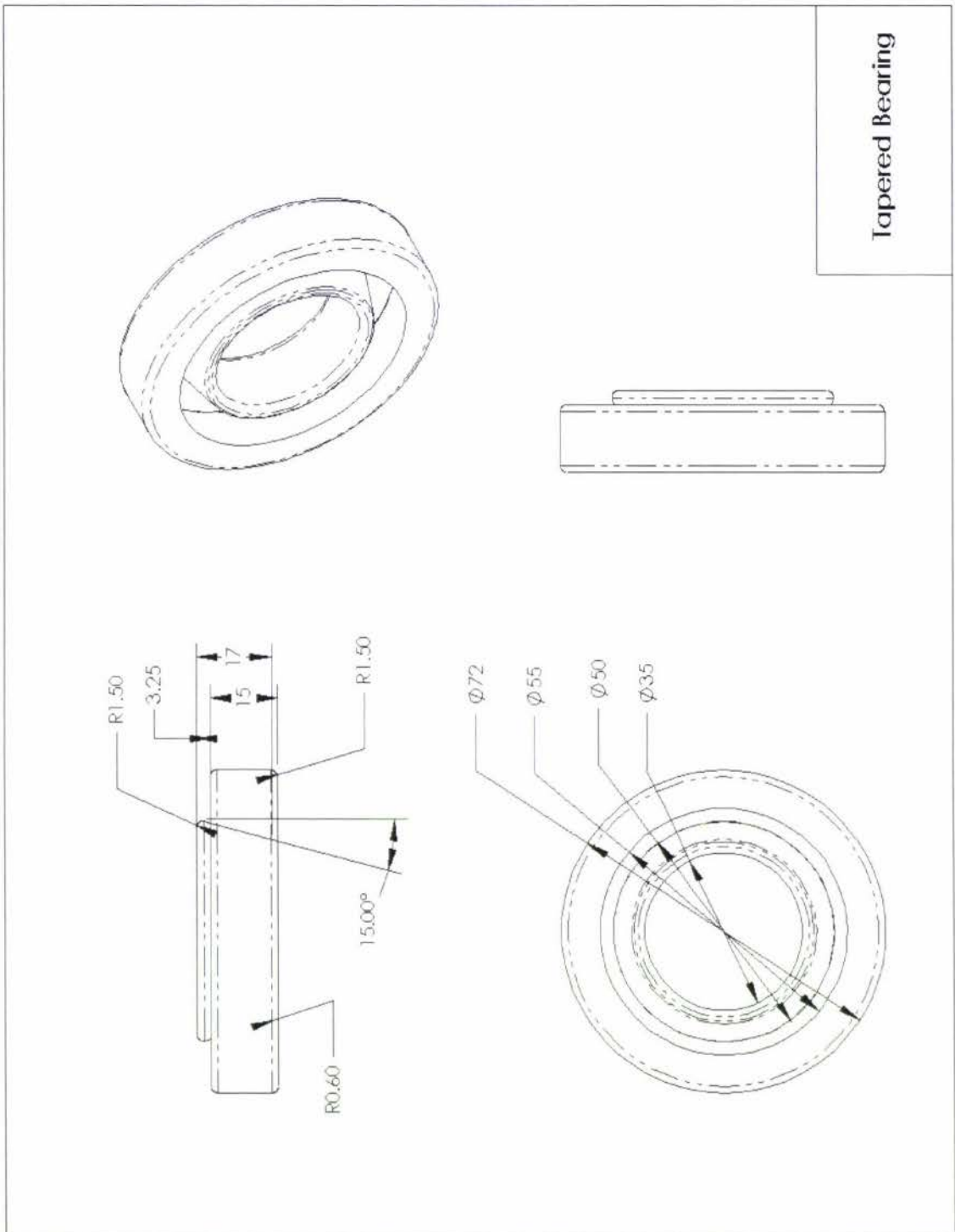

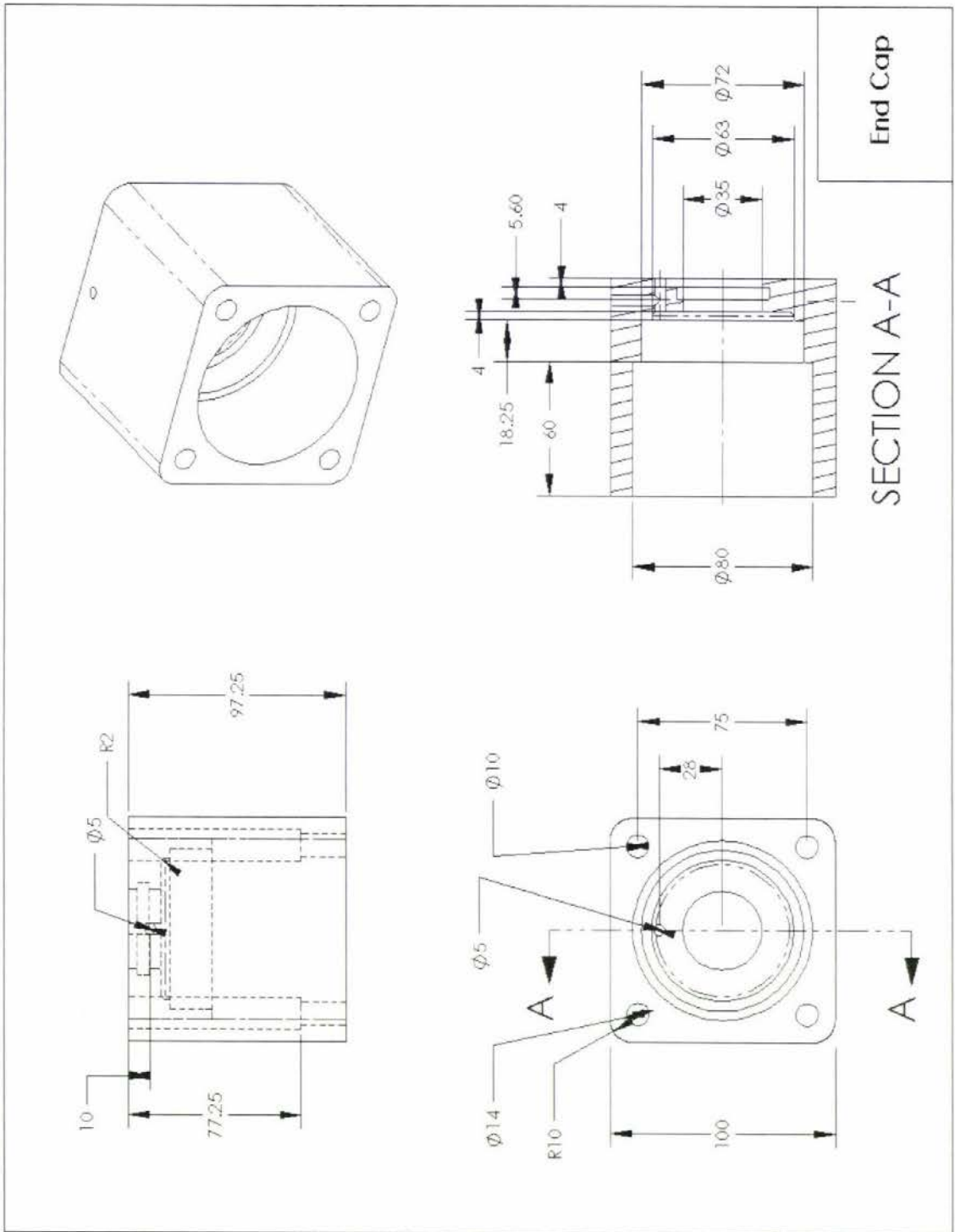

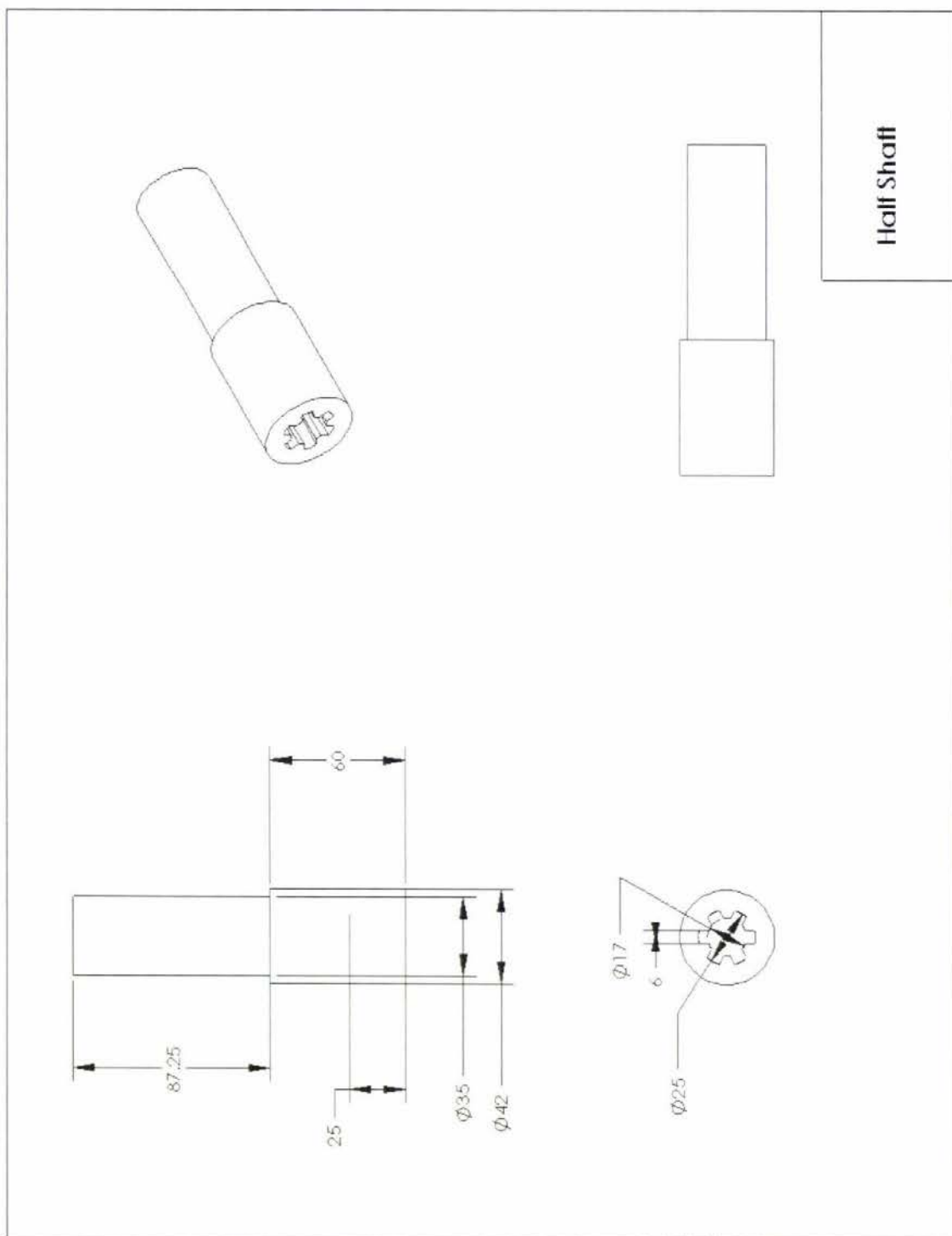

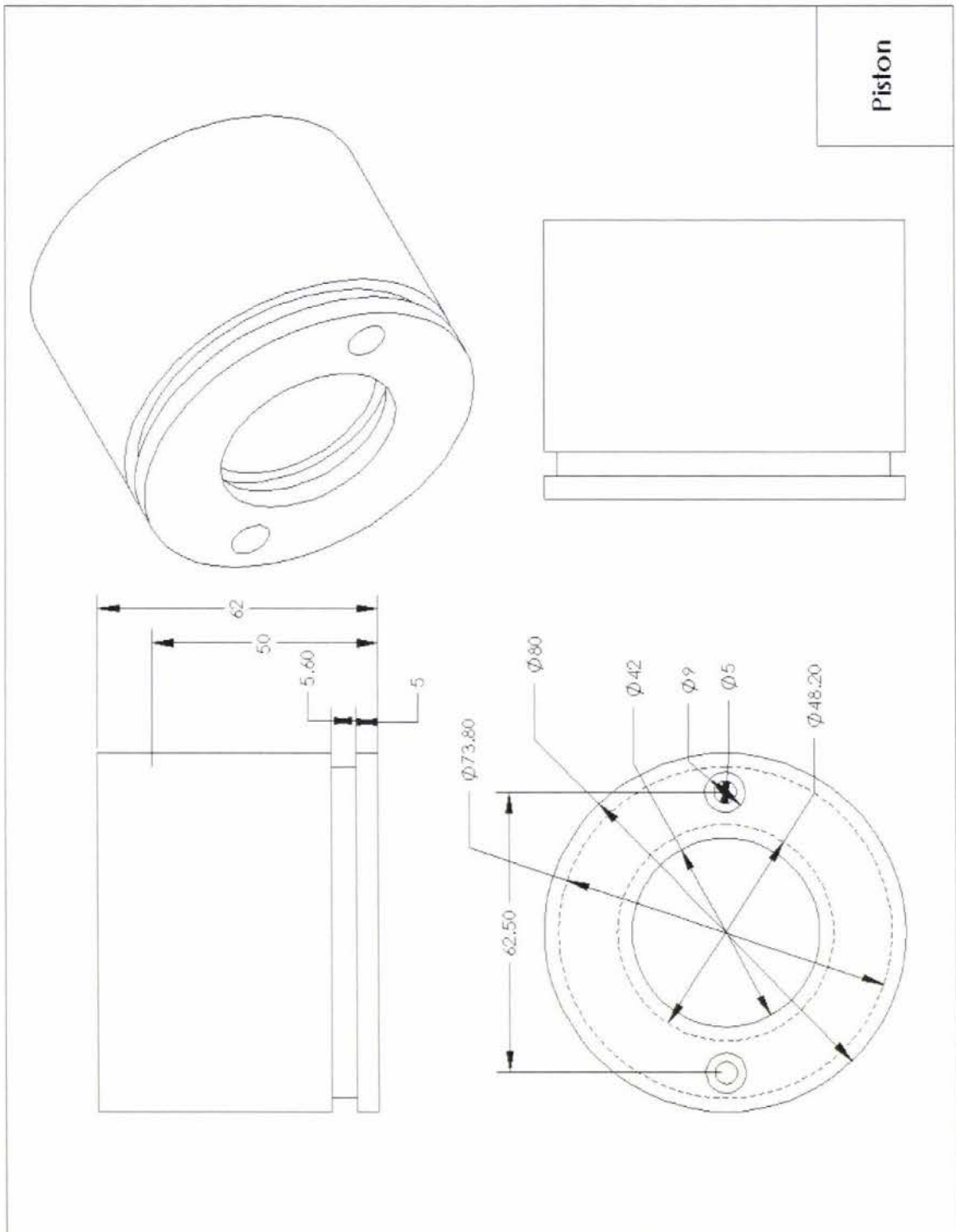

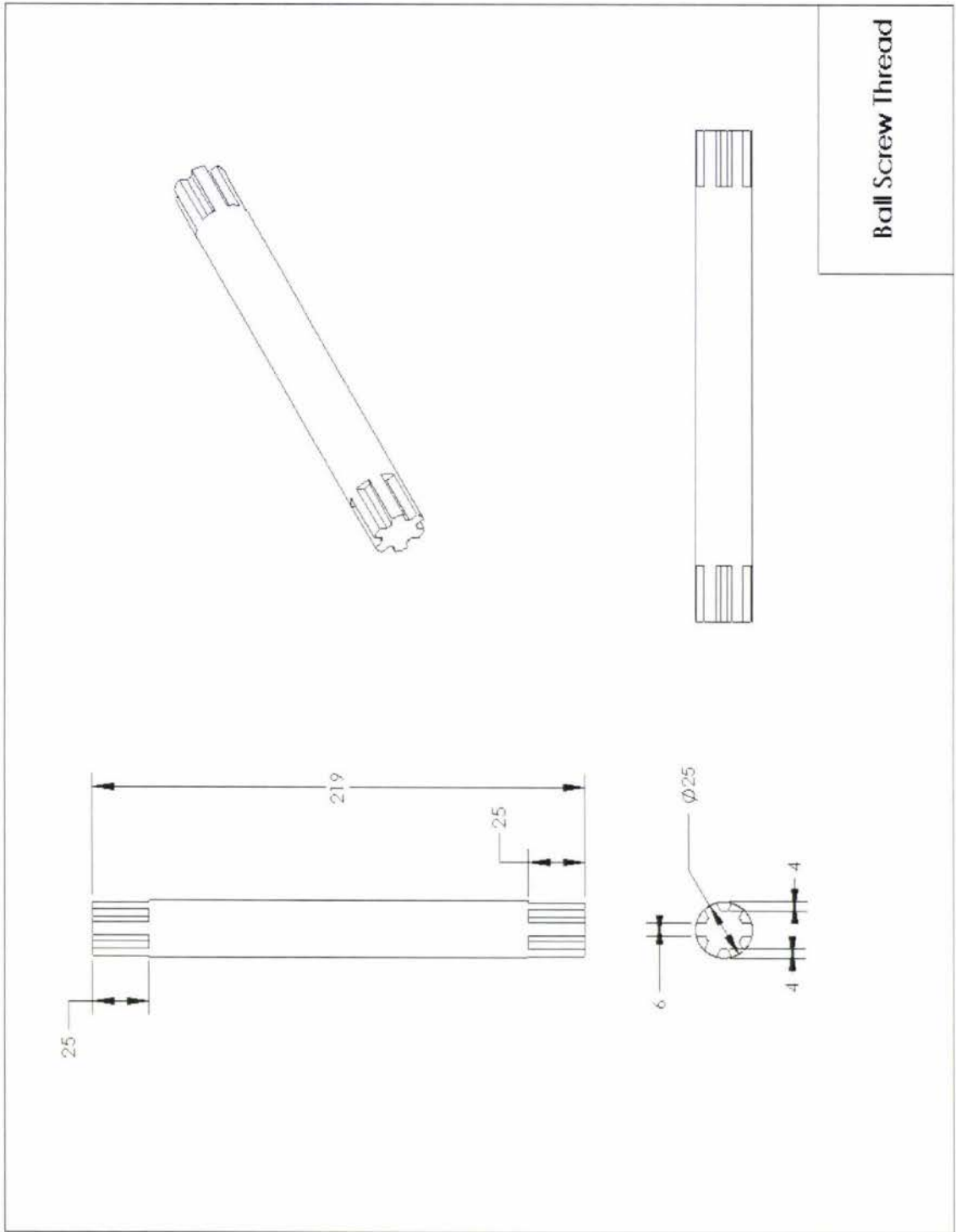

APPENDIX 3: ROTATOR ASSEMBLY PART DRAWINGS

This appendix shows detailed drawings relating to section 3.4

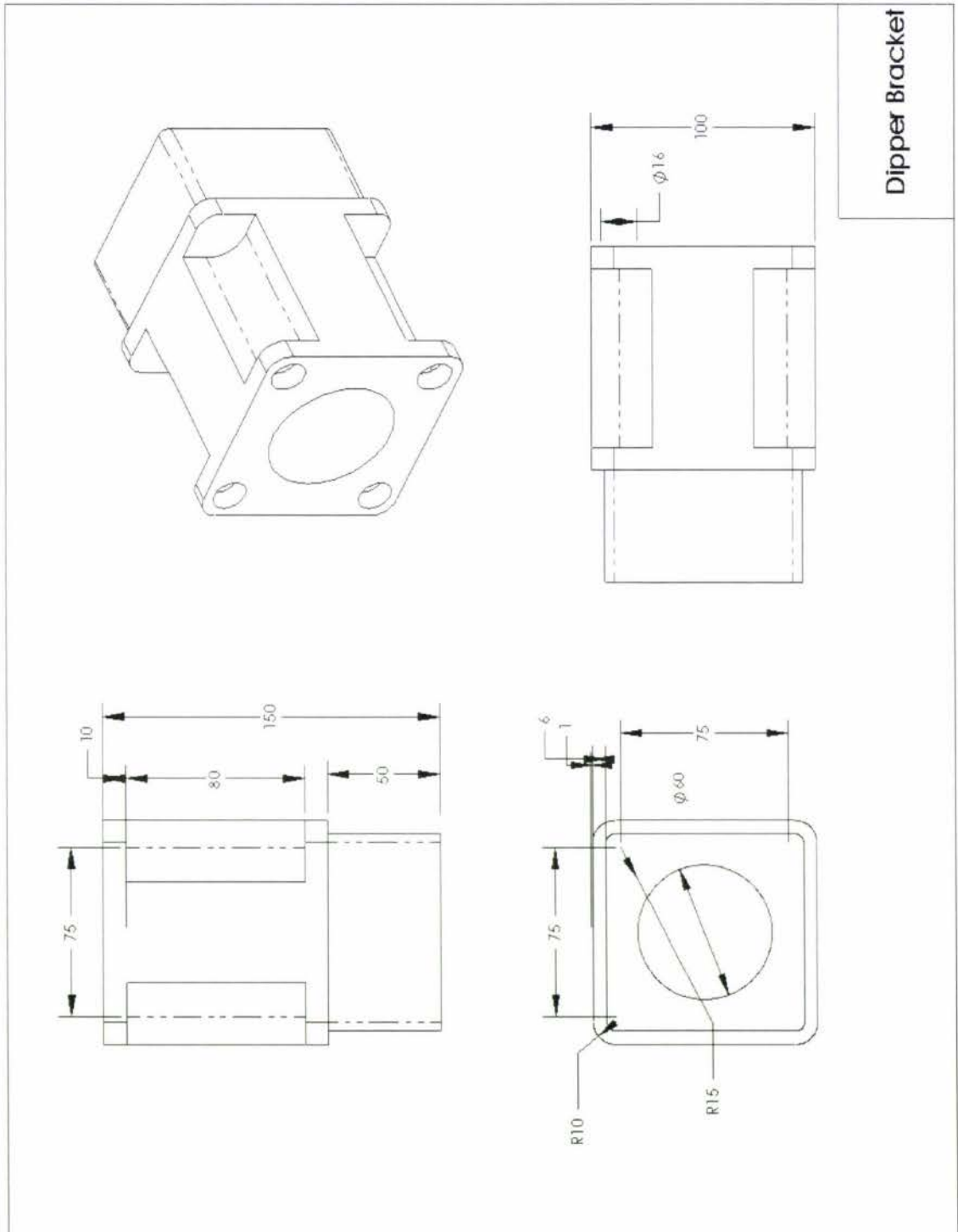

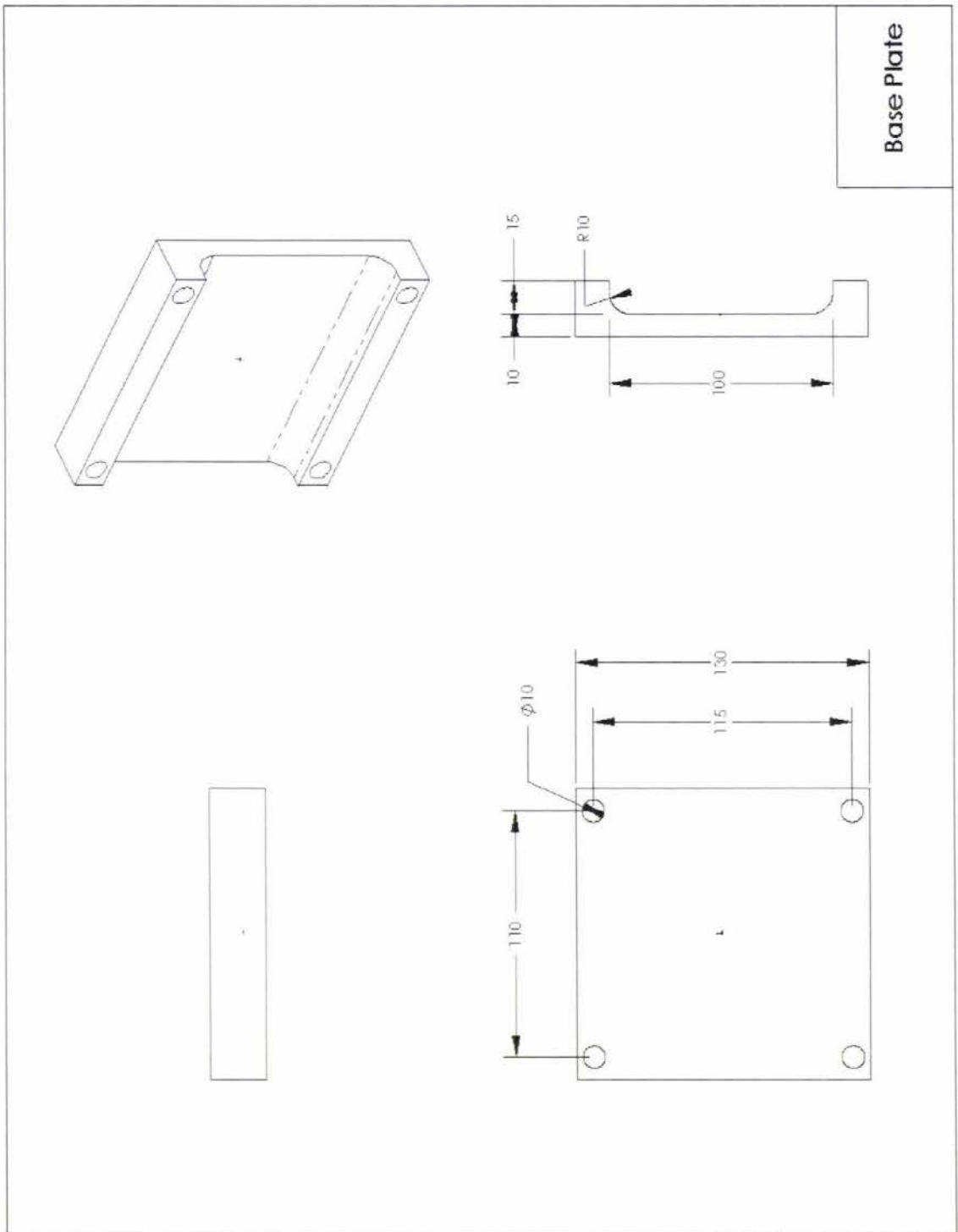

Base Plate

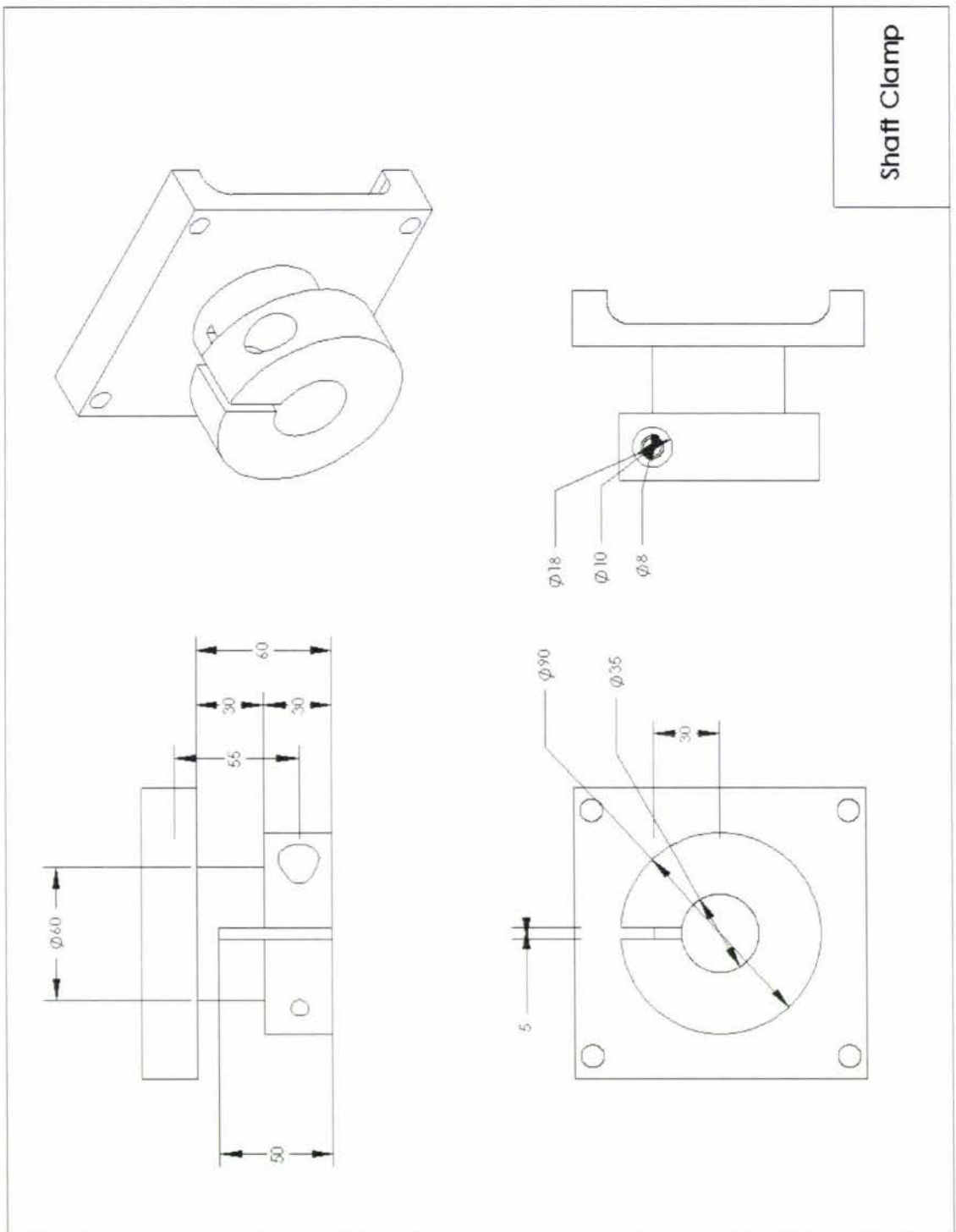

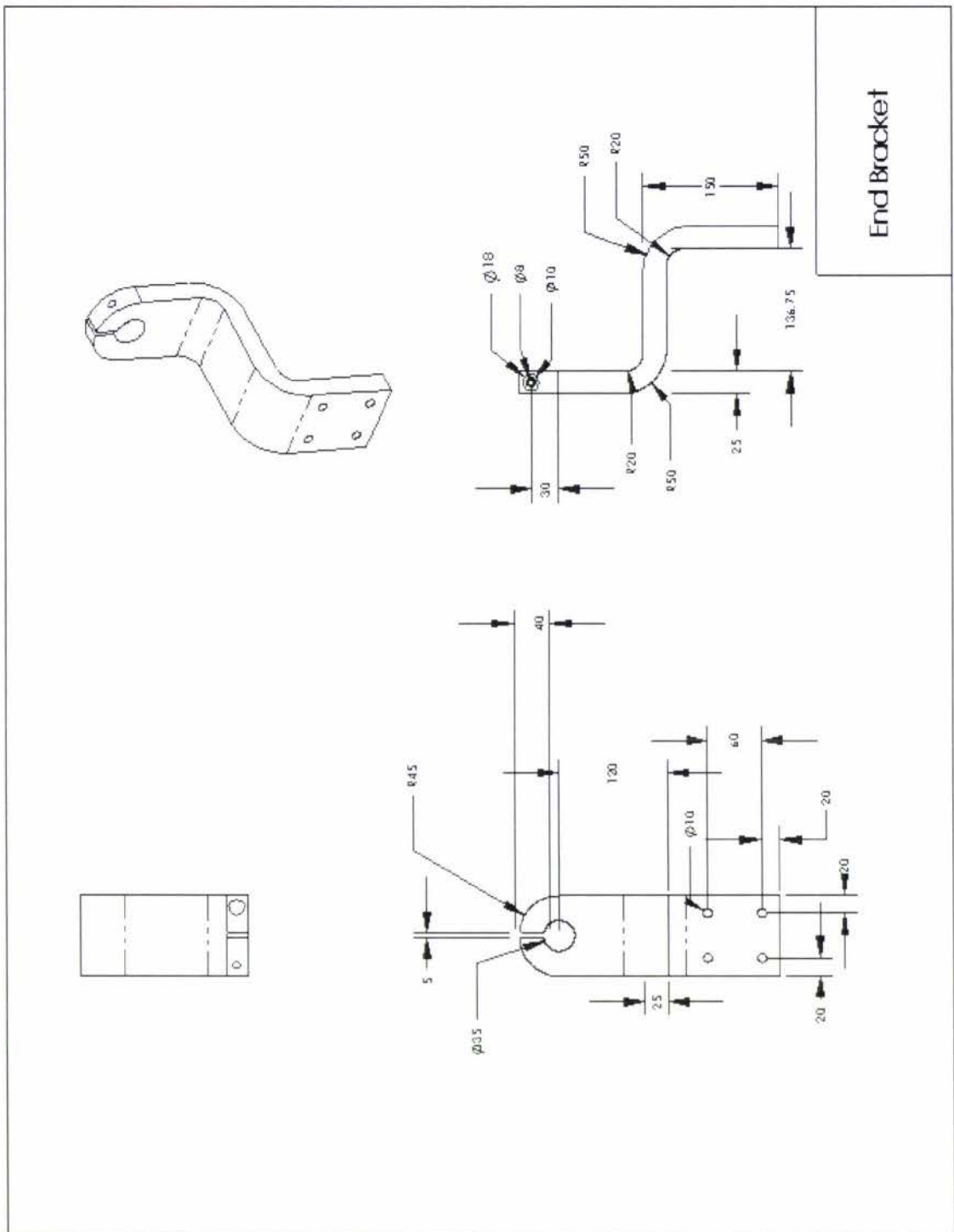

APPENDIX 4: JOYSTICK DRAWINGS

This appendix shows detailed drawings relating to section 4.2.3

