

Copyright is owned by the Author of the thesis. Permission is given for a copy to be downloaded by an individual for the purpose of research and private study only. The thesis may not be reproduced elsewhere without the permission of the Author.

THE POPULATION DYNAMICS OF PORCELLIO SCABER, LATR.

(CRUSTACEA : ISOPODA) IN WASTE GRASSLAND

IN NEW ZEALAND.

A thesis presented in fulfilment of the
requirements for the degree of
Master of Science in Zoology
at Massey University

ROGER G. COX

1971



TABLE OF CONTENTS

Page

FRONTISPIECE

TABLE OF CONTENTS

LIST OF FIGURES

LIST OF TABLES

LIST OF PLATES

ABSTRACT

ACKNOWLEDGEMENTS

1.	INTRODUCTION	1
2.	THE STUDY AREA	3
3.	METHODS	4
	3.1 Sampling	4
	3.2 Sample Analysis	5
	3.3 Growth Study	6
	3.4 Desiccation Experiments	7
	3.5 Measurement of Calcium	8
4.	AGE STRUCTURE	11
	4.1 Introduction	11
	4.2 Size structure	11
	4.3 Discussion	14
	Frequency distribution	15
	Longevity	15
	"Random" and "nonrandom" samples	16
	Abundance of <u>P. scaber</u>	18
	4.4 Conclusions	19

	<u>Page</u>
5. SEX RATIO	20
5.1 Introduction	20
5.2 Results	20
5.3 Discussion	22
Overall sex ratio	22
Causes of mortality	23
Seasonal variation	24
General discussion	25
5.4 Conclusions	26
6. REPRODUCTIVE BIOLOGY	28
6.1 Introduction	28
6.2 The breeding season	28
Results	28
Discussion	29
6.3 Fecundity and fertility	32
Results	32
Discussion	34
6.4 Natality	38
6.5 Mortality	39
6.6 Conclusions	40
7. GROWTH OF <u>P. scaber</u>	41
7.1 Laboratory cultures	41
7.2 Effects of density	42
Results	42
Discussion	43
7.3 Effects of food quality	44
7.4 Measurement of size	45
Results	45
Discussion	46

	<u>Page</u>
7.5 Conclusions	46
8. MEASUREMENT OF CALCIUM	48
8.1 Introduction	48
8.2 Results	48
8.3 Discussion	50
8.4 Conclusions	51
9. SUMMARY	52
10. REFERENCES	54

FIGURES

After Page

- Fig. 1 Diagram of apparatus used in desiccation experiments. The flow rate through the system was 1.2 l./min. 8
- Fig. 2 Chamber which contained one P. scaber individual during the desiccation experiments. 8
- Fig. 3 Size class distribution of P. scaber taken in successive samples from April, 1971, to December, 1971. "Random" and "nonrandom" data are pooled at 4-weekly intervals. 11
- Fig. 4 Monthly size class distribution of P. scaber taken in successive "random" samples. 13
- Fig. 5 Monthly size class distribution of P. scaber taken in successive "nonrandom" samples. 13
- Fig. 6 Size class distribution of P. scaber collected in (i) "Random", and (ii) "Nonrandom" samples, from April, 1971 to December, 1971, at head width intervals of 5 m.u. 13
- Fig. 7 Breeding periodicity of P. scaber in relation to rainfall, temperature, and daylength. Weather data were taken from the "Ministry of Transport", Meteorological Observations, for D.S.I.R. Grasslands, Palmerston North, beginning August, 1969. Daylength data were obtained from the "Tide Tables" of the N.Z. Nautical Almanac, 1971. 28

- Fig. 8 The relation of number of (i) ova, (ii) larvae, and (iii) young, to head width (m.u.) of the P. scaber female. Linear regression equations for each set of data are:-
- (i) $y_1 = 1.3x - 68.8$
- (ii) $y_2 = 0.9x - 37.6$
- (iii) $y_3 = 0.4x - 1.0$ 32
- Fig. 9 Mortality of laboratory reared P. scaber. Graph of survival (%) versus age (weeks). The value of 100% is equivalent to 665 young, from a total of 22 broods. 39
- Fig. 10 Increase in head width among P. scaber individuals, showing growth of animals of maximum and minimum size, as well as mean growth of all individuals studied. 41
- Fig. 11 The relation of body length to head width, in 100 P. scaber individuals. The linear regression equation describing the relationship is: $y = 0.15x - 1.33$ 45
- Fig. 12 The relation of body width to head width, in 100 P. scaber individuals. The linear regression equation $y = 0.06x - 0.72$, describes the relationship. 45
- Fig. 13 The relation of (i) fresh weight, and (ii) dry weight, to head width in P. scaber 45

Fig. 14 The relation between amount of calcium (ppm.) and head width, in 18 gravid and 95 nongravid P. scaber individuals. The linear regression equation for the nongravid slaters is:

$$y = 4.4x - 243.7$$

The gravid individuals are shown by circles on the graph.

48

Fig. 15 The relation between amount of calcium (ppm.) and dry weight (mg.), in 18 gravid and 95 nongravid P. scaber individuals. The linear regression equation for nongravid slaters is:

$$y = 6.3x + 34.0$$

The gravid animals are shown by circles on the graph.

48

TABLES

After Page

Table I	Sex distribution of <u>P. scaber</u> from 4-weekly samples in 1971. "Random" and "nonrandom" samples are combined.	21
Table II	Sex distribution of "nonrandom" samples.	22
Table III	Sex distribution of "random" samples.	22
Table IV	Reproductive status of <u>P. scaber</u> individuals collected in "random" samples.	29
Table V	Reproductive status of <u>P. scaber</u> individuals collected in "nonrandom" samples.	29
Table VI	Effects of density and container size on growth of <u>P. scaber</u> young.	42
Table VII	The relationship of weight gain to leaf matter consumed in <u>P. scaber</u> pairs, after a 6 day experimental period.	49

PLATES

After Page

- Plate I General view of study area, taken in March, 1971, showing the poplar boundary, the nature of the wasteland, and the pegs which mark each 1 x 6 m. unit. 3
- Plate II Detailed view of several study area units. The galvanised iron fence was used to help delimit the boundary of most units. Five cryptozoa boards are shown. 4
- Plate III External sexual dimorphism in male (right) and female (left) P. scaber. The pleopods (ventral surface structures behind the last pair of legs) of the male are pointed, whereas those of the female are blunt. 6

ABSTRACT

The dynamics of an isopod (Porcellio scaber) population in waste grassland are described. Three different generations can be distinguished on the basis of size distributions. A difference in age structure and sex ratio is seen in two areas of the study region. Overall there are more females than males. A cohort of 1000 individuals can produce 6000 young in a year, but only 10% of these survive to become sexually mature. Isopods provide a significant reservoir of calcium in the environment.

ACKNOWLEDGEMENTS

The author is indebted to Dr R.A. Fordham who critically reviewed the manuscript, and who gave assistance throughout the study. Professor J. Riddle, Mr J. Craig, and my wife, also read parts of the manuscript, and offered helpful criticisms.

The photographs were developed and processed by the Central Photographic Unit, Massey University, and the figures and tables were printed by the Printery at Massey University. Dr R.R. Brooks of the Department of Geochemistry made the Atomic Absorption Spectrophotometer available for my use.

Finally, I wish to thank Professor J. Riddle for the use of his department's facilities.

1. INTRODUCTION

Terrestrial isopods occupy a unique place in the Crustacea, being the only representatives of the class which have successfully invaded the land. For this reason, a comprehensive literature on many aspects of their biology has developed. With few exceptions however, early research has concentrated on physiological or anatomical features (Herold, 1913; Vandel, 1925; Gunn, 1937; and Edney, 1951). The pioneer life history studies of Collinge (1915) and Verhoeff (1917) have not, until recently, been followed by demographic work on natural populations. Hatchett (1947) and Brereton (1956, 1957) completed investigations of the age structure and reproductive activity of Cyclisticus convexus, and Porcellio scaber, respectively. Several studies in Californian grassland on Armadillidium vulgare (Paris, 1963, 1965; Paris and Pitelka, 1962), and one by Sutton (1968) in which the population dynamics of two Oniscoid species (Trichoniscus pusillus pusillus and Philoscia muscorum) are compared, complete the major reviews known to the author.

New Zealand, including the subantarctic islands, has 48 species of Oniscoidean isopods (Hurley, 1950). A limited literature is available on these species but is almost completely restricted to descriptive and classificatory reviews (Chilton, 1901; Jackson, 1941; Hurley, 1950, 1961). Population studies are nonexistent, and previous ecological work on the four introduced species (Porcellio scaber, Armadillidium vulgare, Porcellionides pruinosus, and Ligia exotica) has been confined to Europe and North America. Therefore, investigation of the Southern forms is of value.

Porcellio scaber was first recorded in New Zealand in 1847 as P. graniger (Thomson, 1922). It is now common over the country especially near dwellings and other places of habitation, but not in

the untouched native bush. The orientation responses to direct light, contact and humidity, contribute to the gregarious patterns of distribution exhibited by slaters. They occur in large numbers under boards, in grass clumps, and in crevices on trees.

The relative ease with which slaters can be cultured in the laboratory makes them ideal animals for scientific study.

The present thesis is the result of field and laboratory studies conducted on a natural population of P. scaber in Palmerston North. The aim was to build up a dynamic description of the population from data on age structure, sex ratio, breeding and mortality, obtained from one year's sampling in the study area. As well as this, the role of the population as a calcium reservoir in the community was investigated.

2. THE STUDY AREA

Field studies were conducted in a long narrow strip (150 x 6 m) of waste grassland (Plate I) adjoining an experimental orchard at Massey University, Palmerston North. On one side the boundary was provided by a drain one metre deep, and on the other by the outer of two rows of Lombardy Poplars (Populus nigra-italica). Bordering the drain was a small bank which had been built up by infrequent cleaning of the drain. A sub-area marked by pegs into 48 units, each 1 x 6 m, was contained in the main study area. It was from these units that the "random" samples (see below) were obtained.

Variation in floral composition occurred seasonally, although the dominant grasses (Festuca spp, Lolium perenne, Agrostis tenuis, and Dactylis glomerata) were present at all times. Other Gramminous species were Alopecurus pratensis, Bromus mollis, and Holcus lanatus. Herbaceous forms such as Galium aperine, Plantago spp, and members of the Geraniaceae could also be found.

Apart from Porcellio the study area had resident populations of pill slaters (Armadillidae). Nematodes, diplopods, acarinids, and pulmonate gastropods were common, and in almost every "random" sample hemipterans (Super Order Fulgoroidea) were encountered. Rabbits and hedgehogs were seen infrequently.

The soil was a type of yellow-grey earth, with pH varying from 5.0 in the grass, to 7.0 under the poplars. In both regions there was a considerable amount of humus and decaying vegetation, especially poplar leaves.



Plate I. General view of study area, taken in March, 1971, showing the poplar boundary, the nature of the wasteland, and the pegs which mark each 1 x 6 m. unit.

3. METHODS

3.1 Sampling

Previous investigators of the distribution and dynamics of gregarious isopods have used a variety of sampling techniques. Cole (1946) studied the pattern of distribution of Trachelipus rathkei by counting the number under cryptozoa boards placed on the ground. A stratified random sampling method was used by Sutton (1968). In this, samples were taken at random from an area divided into basic units (1.5 m squares). The study of Paris and Pitelka (1962) took small samples from areas that had been subjectively chosen for relative abundance of Armadillidium vulgare.

The present study employed two sampling techniques designated "random" and "nonrandom". In the first, a series of 13 x 13 cm boards was placed in the study area at least eight weeks before sampling commenced (Plate II). Two boards were assigned to each of the forty-eight 1 x 6 m units. A sample comprised a subsample taken from each of six units. One of the two boards in a unit was raised and the area containing the highest density of isopods (determined at a glance) was sampled with a soil corer. The disturbed unit was replaced elsewhere in the same unit.

Subsequent samplings followed the same order of use as in the first forty-eight units. This ensured an eight week lapse before more isopods were removed from the same unit.

An area outside the forty-eight units was used for the "nonrandom" type of sampling. In this, aggregations of Porcellio were sought in clumps of Festuca, and other grasses in the habitat. A sample was taken when it was apparent that isopods were abundant. Again, six subsamples constituted one sample.



Plate II. Detailed view of several study area units. The galvanised iron fence was used to help delimit the boundary of most units. Five cryptozoa boards are shown.

The soil corer used in sampling had an area of 90 cm^2 ($d = 10.7 \text{ cm}$). On each occasion it was forced into the ground to a depth of about 5 cm, so that any slaters in subsurface crevices would be included. In practice, very few slaters were found below the surface litter layer. Each sample was removed to a labelled plastic bag for analysis.

At the laboratory each sample was carefully broken up on a metal tray. In samples containing large numbers of Porcellio the obvious animals were removed direct to a collecting bottle. The remainder of the sample was then placed on the grid of a Tullgren Funnel, and the collecting bottle positioned under the funnel exit.

Six Tullgren funnels were built from rectangular kerosene tins. Each had two grids (one small, and one large sized mesh) over a four sided exit funnel.

Extraction efficiency was fairly high, but in some samples, especially wet ones, considerable numbers of isopods became trapped in the soil. To overcome this each sample was given a quick sorting by hand after extraction was completed. This ensured an almost 100% recovery. Two days use of the following schedule was sufficient to extract most isopods - 8 hours light, 12 hours dark, 12 hours light, 12 hours dark. Collecting bottles were emptied frequently during the extraction; the animals were killed in hot water then stored in 70% alcohol and 5% glycerine in labelled plastic capped bottles.

3.2 Sample analysis

A standard procedure was followed in the analysis of each sample. The head width of each slater was measured under a binocular stereo-microscope (x 40 magnification) with an ocular micrometer (1 micrometer unit, m.u. = 0.027 mm). The distance between the most lateral facets of the compound eyes was taken to represent head width.

Head width was used as the primary size measurement because it remains constant after the animal has been killed and preserved. Expansion or contraction of the body segments during death or storage make the measurement of other parameters, such as body length, much less valid than the unvarying head width.

External sexual dimorphism is a feature of most isopods. The males of P. scaber may be distinguished from females by the shape of the pleopods (Plate III), and by the absence of oostegites during the breeding season. Examination of the pleopods is necessary in individuals lacking oostegites, since they may be nongravid females. Slaters with head widths less than 35 m.u. could not be sexed: all others were sexed, and the breeding condition of females recorded.

During the study, 100 P. scaber individuals from close to the study area were used to determine the relationships between head width and body length, and between head width and body width. Body width was measured at the widest part of the second thoracic segment. Body length included the distance from the most anterior part of the head to the tip of the telson. These data were described by linear regression lines. This was done so that growth increments from other studies on the same species could be related to the increments of head width obtained in the present work.

3.3 Growth study

Laboratory populations were established from twenty-seven individually housed gravid female slaters taken from the field in March, 1971. Petri dishes of two sizes - 4 cm and 9 cm diameter - were used. Each of these had a layer of tapwater agar (1.2% agar containing a fungicide, Nipagin-M) covering the bottom to maintain a high relative humidity. Food, in the form of overwintered poplar leaves, was supplied in excess each week, and drops of distilled water



Plate III. External sexual dimorphism in male (right) and female (left) *P. scaber*. The pleopods (ventral surface structures behind the last pair of legs) of the male are pointed, whereas those of the female are blunt.

added as needed to prevent desiccation of the agar. Even so, a new agar layer had to be poured every $2\frac{1}{2}$ months. A small amount of faecal matter from the old dishes was put in on top of the new agar at each repouring to help maintain the copper balance in the animals (Wieser, 1965, 1966).

As each female gave birth, a record of the number of young, and the size (head width) of at least ten of them was kept. Females from nine (8 small, 1 large) of the twenty-seven dishes were removed to see if their absence had any effect on mortality or on growth in the broods.

Every week the young from each brood were counted and ten were measured. A stream of CO_2 was used to narcotise the brood and thus facilitate measuring. This light anaesthesia lasted only a few minutes, but long enough for ten individuals taken at random to be measured. At no time were the young seen to be killed, or permanently affected, by the exposure to CO_2 .

Older slaters, which would not easily respond to the gas treatment, were kept immobile by a different technique. Individuals were placed on an acrylic mesh on the microscope stage and held stationary by finger pressure on a square of clear cellophane which covered the animal. The mesh permitted the slater to be manoeuvred to the desired position under the lens, while the cellophane enabled the observer to see, and hence to measure, the animal's head width.

3.4 Desiccation experiments

Preliminary analysis of field data suggested that there was a differential mortality rate with age between female and male slaters. A series of experiments investigated the possibility of different rates of water loss from gravid females, as compared with other *P. scaber*.

The apparatus (Fig. 1) was based on that described by Edney (1951). A flow of air (1.2 l./min.) at constant temperature (21°C) and constant humidity (25 - 30% R.H.) was passed over the experimental animals for two hours. Each animal was weighed three times - before the experiment, after one hour, and after two hours desiccation. Stoppered glass vials prevented water loss during weighing. Animals used in the experiment had been kept without food for twenty four hours in an atmosphere of 95% R.H.

Individual chambers were made from glass and plastic tubing. Each plastic tube had a small piece of acrylic gauze (1 mm mesh) glued into it (Fig. 2) to prevent movement of the animals between compartments. The glass tubing was moved up to the mesh, thus providing a continuous system through which air could flow without interruption. A humidity check was taken several times by directing the outflow from the system over a wet and dry bulb thermometer.

Surface area of each slater was determined from the expression, $SA = kW^{\frac{2}{3}}$, where SA = surface area (cm²), k is a constant, and W = wet weight (mg.) of the animal. The constant, k, had a value of 12.4 for nongravid individuals (Edney, 1951). However, it was used for both gravid and nongravid slaters in the experiments because it was considered that the error introduced would not mask any differences in the rate of desiccation.

3.5 Measurement of calcium

Analysis of the calcium content of intact individuals of all sizes was undertaken as a corollary to the main study, so that the mineral reservoir of the population could be assessed. A technique using an Atomic Absorption Spectrophotometer (AAS) was employed. The AAS measures an element's concentration by its capacity to absorb light of a characteristic wavelength (4226 nm for calcium) when that element

Fig. 1. Diagram of apparatus used in desiccation experiments. The flow rate through the system was 1.2 l./min.

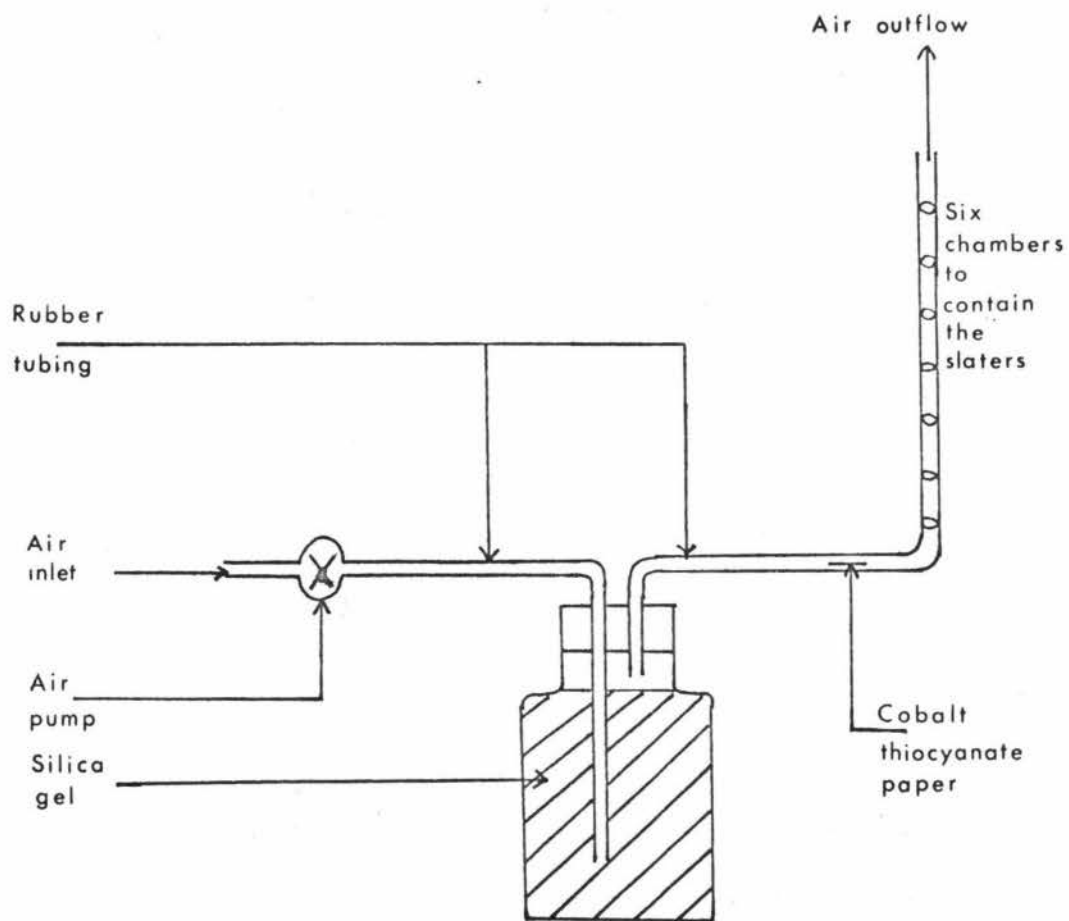
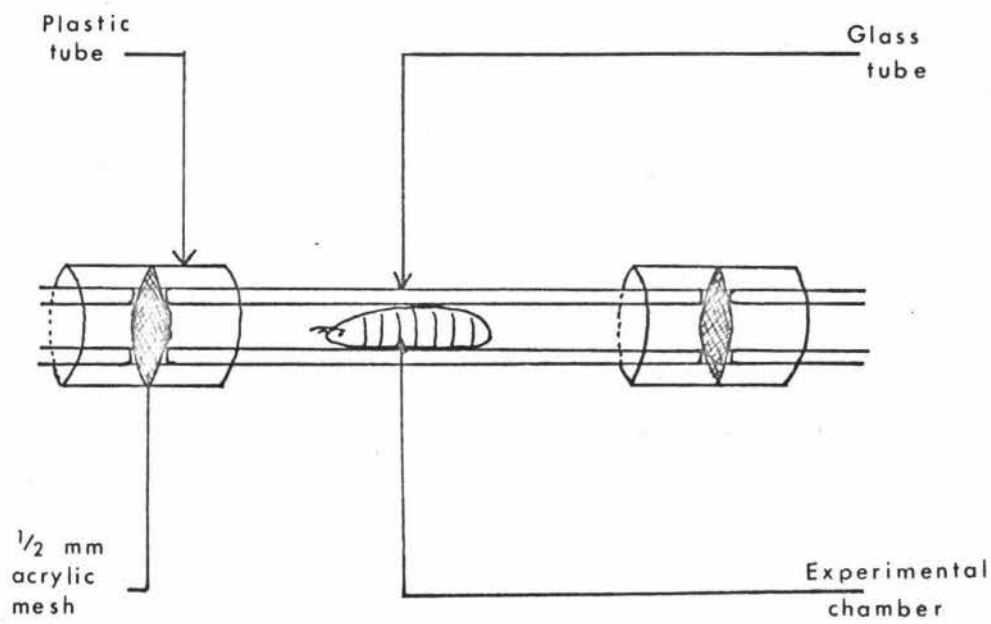

Fig. 2. Chamber which contained one P. scaber individual during the desiccation experiments.



is in its atomic state. Normally, absorption is in direct proportion to the sample concentration.

The procedure outlined below was used for each analysis. Slaters were taken from the study area, sexed and measured, and those about to moult (as shown by white patches on the ventral thoracic segments) were discarded. All animals were killed in hot water, washed twice in distilled water, then placed in individually numbered 5 ml pyrex test tubes, and dried for 18 hours at 100°C. After being weighed on a Mettler balance (accurate to 0.1 mg.) the slaters were ashed at 520°C for 10 hours.

To each tube, 2 ml of 0.8% $\text{Sr}(\text{NO}_3)_2$ in 2 Molar HCl was added; this was warmed gently to ensure solution of the calcium. A 100 μl aliquot was taken from each tube and added to a further 1.9 ml of the acid solution.

Standard solutions of known calcium concentration (100, 50, 20, 10, and 5 ppm) were prepared. These were used to calibrate the AAS and to obtain a standard curve, from which the concentration of calcium in each sample could be determined. A simple equation was employed to derive the dry weight of calcium in each sample. Dry weight (mg.) = $X \text{ ppm}/50$, where X is the concentration of calcium in the sample.

An estimate of the turnover rate of calcium in the population was determined from a feeding study. In this, the standard food came from a batch of overwintered poplar leaves, known to be palatable to slaters. First, the leaves were dried to constant weight, and known quantities were added to petri dishes which each contained two animals of similar size. Humidity was maintained by moist filter paper on the bottom of the dish.

Wieser (1965, 1966) has shown that isopods (*P. scaber*) consume more leaf material than their daily energy production requires

if there is not a substrate of accumulated faeces or organic matter in the dish. The present experiment therefore utilised petri dishes which had held slaters and which contained some faecal material.

After four days the remaining leaf material was washed (to remove faecal deposits), dried and reweighed. The difference in weight was taken to represent the amount consumed by the two animals.

Analysis of the calcium content of the standard food followed essentially the same procedure described above. After being dried, the leaves were ground into powder and weighed. Fixed amounts of this were then ashed in pyrex tubes, and analysed for calcium.

4. AGE STRUCTURE

4.1 Introduction

Age distribution is an important population characteristic which may reflect the current reproductive status of the population. An age structure which is heavily biased toward the younger animals suggests that the population is actively expanding; and a distribution containing a high proportion of old individuals indicates a declining population. The particular age distribution is also closely related to the changes which may be occurring in the other components of the ecosystem.

4.2 Size structure

Population age structure has been illustrated by the frequency histograms of Fig. 3. The histograms represent data obtained in multiple samples from the study area, from April to December of 1971. Each histogram contains the data from all samples at successive 4-weekly intervals. Samples were not collected in some weeks so that any one histogram may not have four contributing sets of data (for example, Number 4). Although each head width was measured to the nearest micrometer unit, the data have been grouped into 4 m.u. class intervals.

Slaters less than one year old have been designated generation 0; those between one and two years old, as generation 1; and so on for the older generations. Age classes estimated from size distributions are shown by numbers in Fig. 3.

The detail of each histogram is sufficient to show its polymodal nature. Each mode represents either a complete generation, or in some instances, the early and late broods of a breeding season (young appear between October and March). As the year passes, the

Fig. 3. Size class distribution of P. scaber taken in successive samples from April, 1971, to December, 1971. "Random" and "nonrandom" data are pooled at 4-weekly intervals.

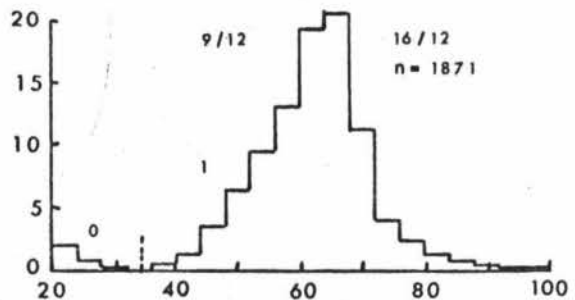
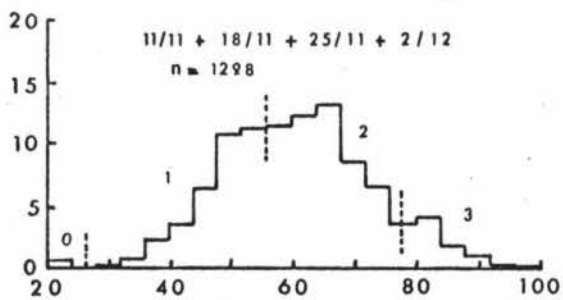
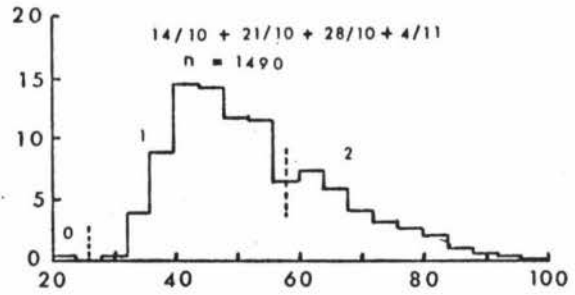
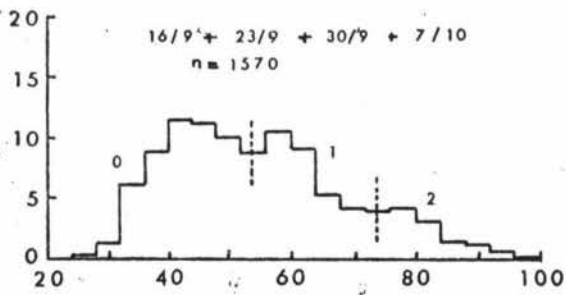
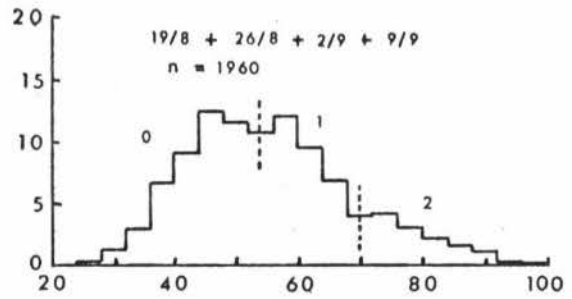
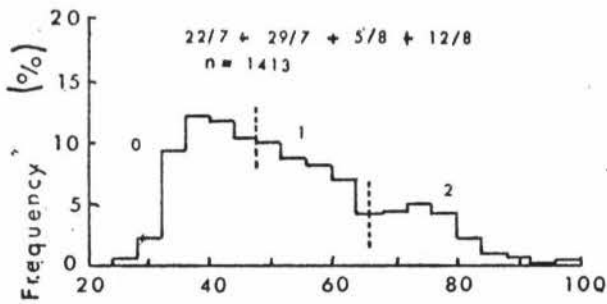
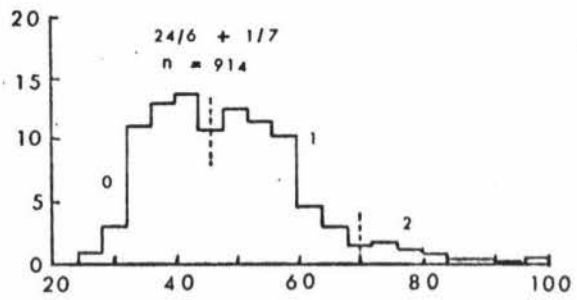
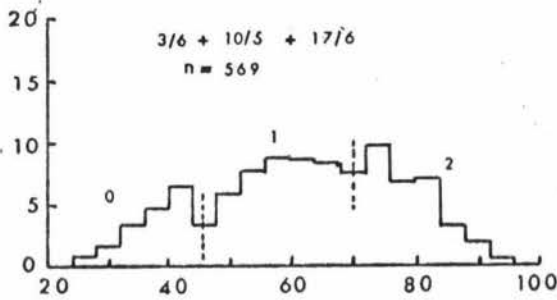
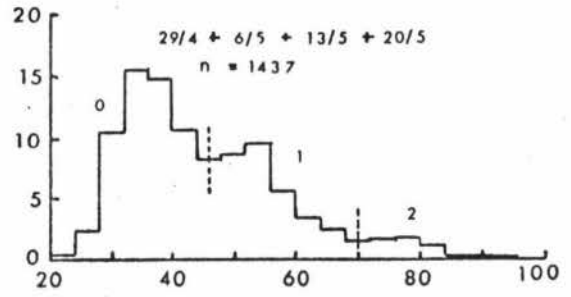
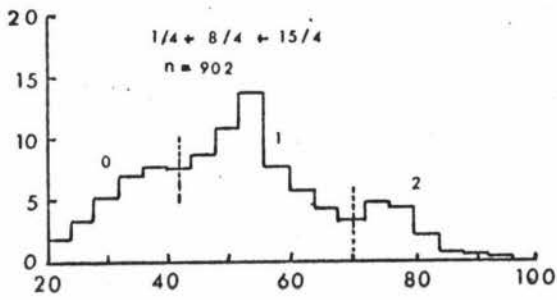

Headwidth (m.u.)

distributions tend to become unimodal, until the next breeding season, when recruitment causes a clear bimodal pattern of distribution. Since the first sample was taken some seven months after the start of the 1970 breeding season, it contains no very young individuals. Individuals from at least three generations are shown in the first histogram; the limits of generation 0 lie between 40 - 44 m.u., generation 1, ending at 68 - 72 m.u., may have two components corresponding to early and late broods; and the second and subsequent generations range from 72 to 100 m.u. This separation of age classes can be followed through each sample to the end of the season. Generation 0 has been arbitrarily designated generation 1 at the start of the new breeding season, in the eighth histogram.

The first young of the new breeding season appear in late October/early November. This is about sixty days after the first gravid females were recorded in a sample. When the young appear, the maximum head width of generation 0 slaters is between 52 and 60 m.u. (from histograms 7 and 8).

Generation 1 slaters reached a maximum size of 72 - 76 m.u. after one year's growth. The combined sample for October/November shows that, if the age classification is valid, the oldest slaters of the population may live for up to 4 years. In fact, one individual not shown on the histograms had a head width of 117 m.u. which suggests an age of 5 - 6 years. No other slaters with head widths over 100 m.u. were collected in the samples. Very young slaters which had been feeding (determined from the dark gut colouration) were classed as free living, and were included in the samples. Others, which had clear bodies were considered to have been released by premature rupturing of the maternal brood pouch by death of the mother, or by physical stresses. These were not counted. The smallest free living young individual had a head width of 21 m.u.

Two types of samples were collected throughout the study (see Methods, Page 4). The month-by-month frequency data from "random" and "nonrandom" samples are shown in Figs. 4 and 5 respectively. Age classes are separated by a line through the data.

With some exceptions, the class distinction shown in Fig. 3 is maintained in both types of sample. There is, however, a major difference in the pattern of distribution of the data from each type; "random" samples tend to have a higher proportion of large animals than "nonrandom" samples. No parametric tests are available to show a statistical difference between the samples, because of the techniques used in collecting. The "random" samples are basically of a stratified random type, whereas the "nonrandom" samples use a subjective "searching" method.

The simple nonparametric test which follows was used to compare the data from each sample type. The modal class of each 4-weekly set of "nonrandom" data was compared with the corresponding "random" set. In eight of the ten months, the "random" samples had a higher modal class, and in one it was equal. The tenth month of the "random" samples had an equal or higher modal class (the mode spanned two 5 m.u. intervals).

Another comparison illustrates the difference between the types of sample. The pooled data from all "random" samples ($n = 4202$) and all "nonrandom" samples ($n = 9325$) are shown on separate histograms in Fig. 6. The "random" set could be described as nearly normal, whereas the "nonrandom" data is heavily biased towards the small size classes. In fact, the percentages of individuals which are less than a year old (under a head width of 55 m.u.) are 25.2% and 75.2% respectively. Even so, there is a slightly higher proportion of very young individuals (first age class) in the "random" data.

Fig. 4. Monthly size class distribution of P. scaber
taken in successive "random" samples.

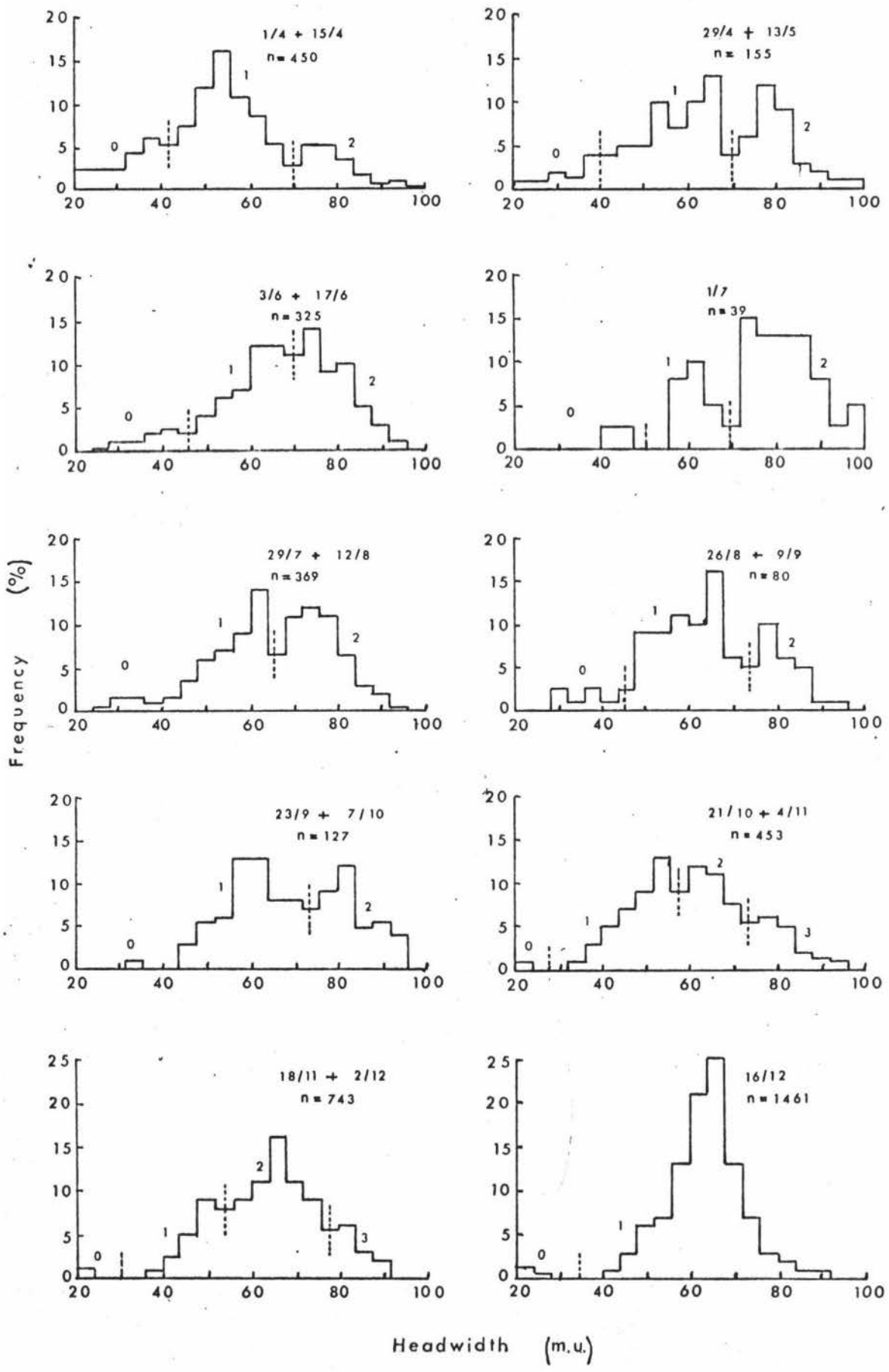

Fig. 5. Monthly size class distribution of P. scaber
taken in successive "nonrandom" samples.

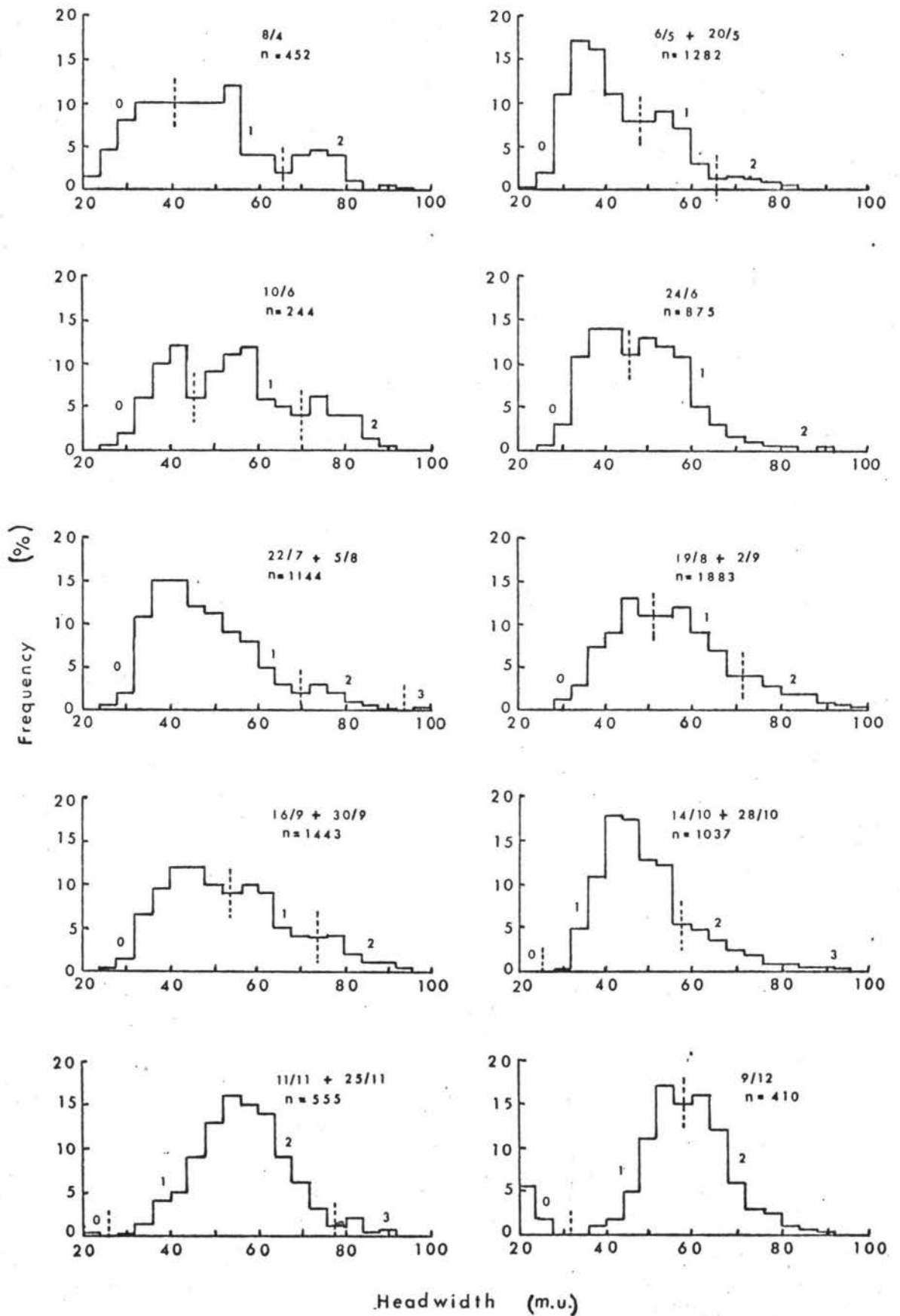
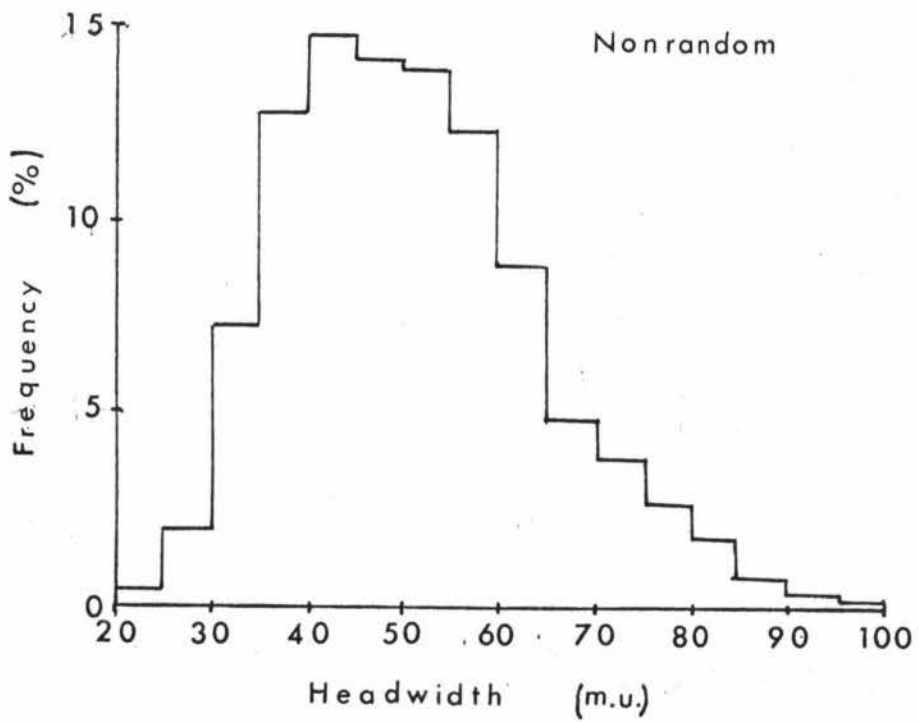
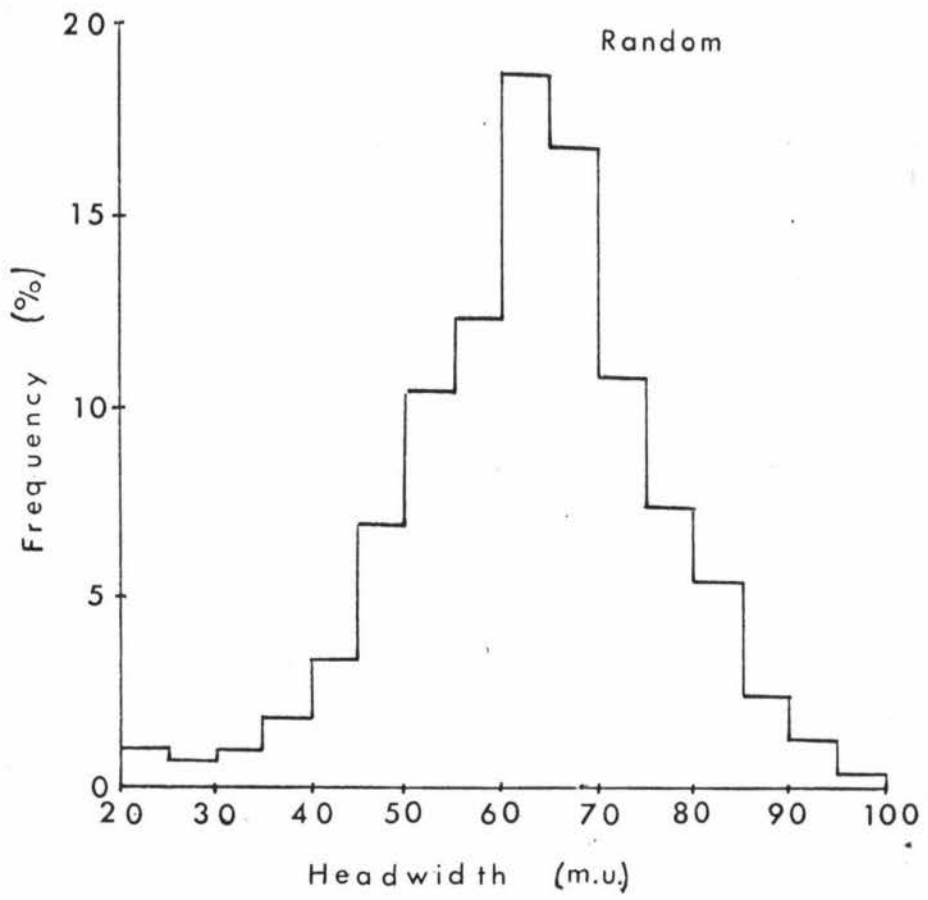

Fig. 6. Size class distribution of P. scaber collected in (i) "Random", and (ii) "Nonrandom" samples, from April, 1971 to December, 1971, at head width intervals of 5 m.u.



It is highly probable therefore, that the two types of sampling technique used in the study each collect a different sector of the population in their samples. Possible reasons for this will be discussed below.

A considerable difference exists in the mean number of isopods taken per soil core, for "random" and "nonrandom" samples (six cores = one sample). For the first type, the average was 39 individuals per 90 cm² core, and for the "nonrandom" type it was 97 individuals. The last "random" sample had 1461 slaters; the highest total for a six core sample in either set of data. If this exceptional value is omitted from the calculation, the mean number of isopods per core for "random" samples is reduced to 27.

In all the "nonrandom" data there is only one monthly set which contains less than 800 individuals for two samples (the first, third, fourth, and final sets contain data from only one sample). On the other hand, only one "random" set has more than 800 individuals; and that is a one-sample set.

There is some evidence that a correlation exists between weather conditions and abundance of isopods in the "random" samples. In three 4-weekly samples, one of the two contributing samples was collected when the ground was wet. The number of isopods in these wet weather collections was always less than the number in samples taken on dry days. Also, over the consistently wet September/October period, the mean number of P. scaber in each "random" sample soil core was less than 10 individuals. For the corresponding period, the "nonrandom" figure was 121 isopods per soil core.

4.3 Discussion

Casual observation had shown that a large reservoir of isopods was present outside the confines of the study area. No decline

in numbers which could be attributed to "overfishing" was noticed throughout the year. Therefore, the data obtained are considered to represent adequately a natural population of Porcellio scaber.

Frequency distribution

A number of studies on terrestrial isopods have given data on the size structure of the populations in nature. Similar distributions were obtained for Cyclisticus convexus (Hatchett, 1947), P. scaber (Brereton, 1956; Amanieu, 1965a), and A. vulgare (Paris and Pitelka, 1962). All showed a bimodal frequency distribution of size classes at the early part of the breeding season. This reflected the presence of members of the new generation, plus individuals of older age groups. As the year passed, there was a tendency for the distribution to become unimodal, as the actively growing young generation attained the same size as the slow growing old isopods.

The results of this study show the same general trends as above, except that the bimodal breeding season period is represented by only the December histogram. The first month sampled (April) shows the young generation at a size equivalent to small members of generation 1. In Fig. 3, the histograms tend to be polymodal in detail, with consistent breaks in the distributions indicating the existence of different generations.

Longevity

At least three separate generations can be seen in the data of Fig. 3. A fourth generation is possible in several of the histograms. This indicates that P. scaber in New Zealand may live for three, or in some cases, four years. The very large P. scaber female which had a head width of 117 m.u. may have been even older.

The longevity of the larger Oniscoids, P. scaber and O. asellus has been estimated to be three or four years in at least

four studies (Verhoeff, 1920; Herold, 1924; Heeley, 1941; and Brereton, 1956). Brereton (1956) showed that the bulk of the population in the field consisted of individuals less than three years old. In Porcellio laevis, only the males attain the maximum age of four or five years (Geiser, 1934). The maximum length of life of smaller forms, such as Trichoniscus pusillus, is usually three years or less (Heeley, 1941).

The present study provides no data on longevity but the life spans of laboratory cultures elsewhere have been lower than would be expected from field data. Isopods from four species, including P. scaber, were raised in the laboratory in Michigan by Hatchett (1947). These lived for only about two years.

"Random" and "nonrandom" samples

It is clear from the results above that the two methods of sampling did not sample the same section of the population. The "random" samples appeared biased towards the older generations, whereas the "nonrandom" samples took a much higher proportion of juveniles. In many respects these two samples respectively approximate models of declining and expanding populations. It is extremely unlikely that two such populations could exist immediately adjacent to one another in an apparently uniform habitat. Thus, the difference appears to have resulted from the type of sampling used.

In seeking explanations for this difference, the distinction between the sampling types must be borne in mind. "Nonrandom" samples were collected after aggregations of P. scaber had been found by actively searching the grass habitat. "Random" samples, on the other hand, were taken from under wooden boards laid out in a stratified random grid pattern.

The "nonrandom" samples consisted mainly of young animals with a relatively small proportion of more than one year of age. Normally, this would indicate either a high mortality rate after the first year, or an "exploding" birth rate in the previous breeding season. Yet we find a high proportion of these older individuals in the "random" samples. An alternative to the "high mortality" or "exploding birth rate" hypothesis is needed.

Instead of a high mortality rate after the first year, there may be a behavioural change. This, acting through different habitat preferences, may result in a different pattern of distribution of the older individuals. It is also possible that a difference in diet preference or requirements may tend to restrict the young animals to grass regions. Small individuals of Armadillidium pallasei (Muller, 1943) have a higher metabolic rate per unit body weight than larger individuals. It is likely therefore, that the young actively growing P. scaber would need a higher weight-specific intake of food than old slower growing slaters. This may result in young animals remaining in areas where food is available and avoiding those regions, such as under the boards, where it is likely to be scarce. Den Boer (1961) showed that P. scaber will eat almost any organic material presented to it. Dead plants, live mosses, algae, fungi, slater bodies, and shed slater cuticles are some of the foods which P. scaber will consume. The possibility of a differential food preference with age was not considered by Den Boer, but the present work indicates that it may play a role in the dispersion of P. scaber.

The moult period is one in which the isopod is extremely vulnerable to microclimatic changes, predation, or to the cannibalistic tendencies of its conspecifics. A slater in moult requires a site protected not only from variations in weather, but also from its fellow slaters. The individuals of generation 0, which moult about 15 times

in their first year of life (Heeley, 1941), have a greater need for suitable moult sites than their older counterparts which moult less frequently. The Festuca clumps, and grass area in general, probably offer a greater number of suitable sites for moulting than do the boards. This may contribute to a differential pattern of distribution of the two groups in the habitat.

All the samples were taken in daylight (at 1500 hours) so that the site of capture may be considered as a place in which to hide. The literature (Cole, 1946; Den Boer, 1961) has shown that the slater's choice of site is usually related to the degree of protection against desiccation which it provides. In general, moist sites are preferred to dry ones. In this study, however, the area under the boards has sometimes been considerably drier than the surrounding vegetation, and yet has contained isopods. The converse has also occurred. There is no simple explanation for the patterns of size distribution shown between the two sample types. Food preferences, moulting, and physiological requirements may all influence the choice of a daylight refuge. More research is necessary to evaluate the contributions of each of these, and perhaps other factors.

Abundance of *P. scaber*

Isopods were common in the area for the duration of the study. There were no great fluctuations in numbers in the "nonrandom" samples, although an increase in searching time was noted for the last few samples. On the other hand, a considerable decrease in numbers was displayed by the samples taken from under the boards in winter. It is likely that this reflected a decrease in popularity of the boards as a shelter site, rather than a decrease in abundance of the isopods. This notion is borne out by the large collections which were taken in spring, after the weather had improved. In addition, there were dense aggregations under some poplar logs outside the study

area when the boards had few individuals under them.

In the course of the study, the poplar trees were topped, and the logs stacked along the row of trees on the outer perimeter of the study area. After some time, it was noted that these logs had very large numbers of P. scaber individuals underneath them. Since this may have had an effect on the sampling, these logs were removed. In the "random" sample taken immediately after this, nearly 400 isopods were collected, whereas in the five samples previous to this, never more than 100 individuals per sample had been collected. However, because the log removal coincided with a spell of very warm dry weather, and because the preceding five weeks had been wet, the effect on the sample may not have been directly related to log removal.

4.4 Conclusions

If the results from both "random" and "nonrandom" samples are considered together, then the age structure suggests that the population is in a state of relative stability. By itself, each sample type departs from this; either toward the state of declination, as in "random" samples, or as an expanding population as shown by the "nonrandom" data. The causes of this difference between samples are uncertain, but may be associated with the requirements for feeding, moulting, or general physiological wellbeing.

5. SEX RATIO

5.1 Introduction

Sex ratios can assist in the description of populations. Patterns of mortality in each sex with age, for example, may become apparent after analysis of standard samples taken at different times throughout the year. The recruitment of sexually maturing young animals may also be reflected in such samples.

In this study, the significance of differences between the ratio of males to total individuals has been assessed by using a Normal Approximation Test (Bailey, 1959). Two levels of significance ($p = 0.05$, $p = 0.01$) have been used in describing the differences.

5.2 Results

The proportion and the number of each sex, measured at 4-weekly intervals is seen in Table I. Both "random" and "nonrandom" data have been pooled according to their date of collection. In the three months, April, June and late September, the ratio of males to total individuals is significantly greater than 0.5, ($p = 0.05$). The late December sample has a ratio of over 2 : 1 in favour of the females; and overall there are significantly more females than males ($n = 12690$). However, before the final sample, the overall sex ratio slightly favoured the males.

After the commencement of the breeding season, there is an increase in the proportion of females collected. In the nonbreeding part of the year, males predominate, whereas, after early September the ratio of males to total individuals is considerably less than 0.5.

Some variation exists between the results of the two types of sampling; overall, the "random" technique collected a high proportion of females, while the "nonrandom" samples did not differ

TABLE I

Sex distribution of P. scaber from 4-weekly samples in 1971.

"Random" and "nonrandom" samples are combined.

Collection Dates	Number of Individuals ♂ ♂ : ♀ ♀	Totals $\frac{\delta}{\text{♀}} \times 100$	
April 1, 8, 15.	420 : 351*	120	Non-Breeding Season ♂ ♂ : ♀ ♀ 3401 : 3223* n = 6624 $\frac{\delta}{\text{♀}} \times 100 = 106$
April 29. May 6, 13, 20.	599 : 536	112	
June 3, 10, 17.	303 : 235**	124	
June 24. July 1.	416 : 442	92	
July 22, 29. August 5, 12.	729 : 691	106	
August 19, 26. Sept. 2, 9.	944 : 968	98	
Sept. 16, 23, 30. Oct. 9.	801 : 700*	114	
Oct. 14, 21, 28. Nov. 4.	716 : 743	96	
Nov. 11, 18, 25. Dec. 2.	592 : 692	86	
Dec. 2, 16.	596 : 1226**	49	
Total	6016 : 6584**	93	

* Proportion of males differs from 0.5 at the 0.05 level of significance.

** Proportion of males differs from 0.5 at the 0.01 level of significance.

from an equal sex ratio.

When the results are divided into two age classes on the basis of head width (less than one year old; older than a year), for each sampling type, further differences are seen. In the younger group of the "nonrandom" data (Table II) the ratio of males to total individuals is 0.474, ($n = 5078$, $p = 0.01$). This trend is reversed for the older slaters with the exception of the September collection. Collections in the first three months (Table II) have significant male predominance. If the pooled data from these older slaters are divided into two further classes corresponding to generation 1, and to older individuals, the number of males/total individuals = 0.524, ($n = 2961$) for the first generation. This difference from 0.5 is significant at $p = 0.05$. The remaining older animals ($n = 555$) have a sex ratio which does not differ from 0.5. When all "nonrandom" data is pooled, the sex ratios do not differ from unity.

In the "random" sample data (Table III), males predominate in most age groups, in contrast to the results just given. The April, May and June samples have greater numbers of males (significant at $p = 0.01$), as do the August and October samples. However, the last two samples (November and December) contain a very high proportion of females, but only in the older animals. There are many more males than females in the younger group of each sample.

The pooled data from the older slaters in Table III have a highly significant proportion of females. This is due almost entirely to the influence of the large final sample which contained a high proportion of females. Before this sample was collected, the males predominated. The sex ratio of young slaters remained in favour of the males. In generation 1 slaters, the ratio of males to total slaters is 0.386 ($n = 2455$, $p = 0.01$) whereas in slaters of other ages the ratio is not different from 0.500.

TABLE II

Sex distribution of "nonrandom" samples

Collection Dates	Generation 0 Individuals ♂♂ : ♀♀	Older Individuals ♂♂ : ♀♀	Totals $\frac{\sigma}{q} \times 100$
April 4.	108 : 127	76 : 53*	102
May 6, 20.	336 : 386*	165 : 100**	103
June 10.	50 : 63	68 : 40**	104
June 24.	262 : 310*	123 : 114	91
July 22, Aug. 5.	341 : 397*	167 : 156	81
Aug. 19, Sept. 2.	449 : 464	449 : 472	96
Sept. 16, 30.	354 : 378	369 : 274**	111
Oct. 14, 28.	344 : 385	144 : 140	93
Nov. 11, 25.	113 : 102	156 : 178	96
Dec. 9.	54 : 55	133 : 139	96
Total	2411 : 2667**	1850 : 1666**	98

*, ** - notation as for Table I.

TABLE III

Sex distribution of "random" samples

Collection Dates	Generation 0 Individuals		Older Individuals		Totals $\frac{\sigma}{\text{♀}} \times 100$
	♂♂	: ♀♀	♂♂	: ♀♀	
April 1, 15.	103	: 79	133	: 92**	138**
April 29, May 13.	26	: 15	72	: 35**	196**
June 3, 17.	25	: 18	160	: 114**	140**
July 1.	2	: 0	19	: 18	117
July 29, Aug. 12.	33	: 26	188	: 112**	160**
Aug. 26, Sept. 9.	11	: 8	35	: 24	144
Sept. 23, Oct. 7.	9	: 7	69	: 41**	160**
Oct. 21, Nov. 4.	63	: 68	165	: 150	105
Nov. 18, Dec. 2.	97	: 60**	226	: 352**	78**
Dec. 16.	118	: 82**	291	: 950**	40**
Total	497	: 363**	1358	: 1888**	82**

*, ** - notation as for Table I.

5.3 Discussion

Overall sex ratio

A greater number of females than males has been shown for the present study, but it must be noted that before the final sample was taken, the sex ratio favoured males. In addition the two types of sampling each have different proportions of the sexes; equal numbers in "nonrandom" collections and female preponderance in "random" samples. As above, a sex ratio that favoured males existed before the final sample of the "random" type.

In juvenile P. scaber from pooled "random" and "nonrandom" samples the sex ratio did not differ from 1 : 1. However, this figure is the result of two sets of data which did vary; one from "random" samples favouring males, and the other from "nonrandom" samples favouring females. It appears that each sampling type collects a different sector of the population (see also Page 16).

The literature contains quite divergent sex ratio values for many of the bisexual isopod species. Vandel (1925) found that the sex ratio of adults in all species known to him (except Trichoniscus depaxi), favoured the female. Since these were small samples, they have been criticised (Geiser, 1934) as being statistically unreliable. However, females outnumbered the males in collections of Tracheoniscus rathkei (Geiser, 1934), Cyclisticus convexus (Hatchett, 1947), and P. scaber (Brereton, 1956). Similarly, Howard (1940) recorded 71% females in an English sample of A. vulgare, and Amanieu (1965b) found 61% females in a French population of P. scaber. Males were predominant (58%) in a sample of 1527 A. vulgare collected at Dallas, U.S.A., by Geiser (1934).

Laboratory reared broods were said to contain equal proportions of both sexes at birth (Vandel, 1925), although later,

Vandel (1939) reported great variability in the sex ratios of A. vulgare broods. Juvenile A. vulgare and P. laevis had sex ratios of 1 : 1 in the study of Geiser (1934), and in the same study, another collection of T. rathkei (n = 381) had a similar sex ratio.

The hypothesis of a differential mortality rate between the sexes proposed by Geiser (1934) is also supported here. In the slaters of generation 1 there are 53% females (significant at $p = 0.01$), whereas in those of generation 2 or older, the males are favoured, (at $p = 0.05$). Thus the mortality rate for males is higher than for females in the second year of life (generation 1); but those males which survive to the third year tend to be more viable than the females of a corresponding age. Brereton (1956) has reported a sex ratio for P. scaber which progressively favours the males as the slaters grow older. In P. laevis only the males attain the maximum age of four or five years (Geiser, 1934), and in A. vulgare in California there are more males than females in older generations (Paris and Pitelka, 1962).

Causes of mortality

Geiser (1934) suggested that female mortality at the reproductive ecdyses would lead to greater male survival, and that the slaters in moult would be more susceptible to desiccation, predation, and unfavourable changes in microhabitat. Hatchett (1947) found that many G. convexus females died during the moult following brood release. In laboratory cultures of A. vulgare, Paris and Pitelka (1962) occasionally noted the death of females after release of the brood. In the present study, three females from 27 cultures died of undetermined causes within two days of giving birth to their young.

Experiments were conducted on P. scaber to determine if a differential rate of water loss existed between gravid and other individuals (see Methods, Page 7). The results from the experiments

did not show any significant differences in the calculated rates of water loss. However, if the true surface area of the gravid females had been used, instead of an approximation based on the value determined by Edney (1951) for nongravid P. scaber, then their rate of water loss may have been considerably less than the other group. It appeared that the brood pouch was acting to prevent water loss from the ventral thoracic surface. It had been shown previously (Edney, 1951; Den Boer, 1961) that male and nongravid female P. scaber have equal rates of water loss.

Although the desiccation results above are inconclusive, it seems reasonable that the possession of a brood pouch would, in itself, lead to decreased mobility, and loss in ability to utilise crevices and other hiding places. This, in the relatively hot, dry climatic conditions of summer, may reduce the viability of the females which are gravid.

Seasonal variation

In their comprehensive study on A. vulgare, Paris and Pitelka (1962) took frequent samples over a year. They reported small differences in sex ratio, sometimes favouring males, sometimes favouring females, in 42 samples. The number of males was significantly less than the number of females in only four samples, and significantly greater in two samples.

Recent work in France (Amanieu, 1965b) on P. scaber showed that a seasonal pattern of sex ratio variation existed in the population studied. In spring and summer the percentage of males was small. Towards the end of summer, the proportion increased, until the males were more numerous than the females. Over winter the males maintained a stable 45% of the total.

Amanieu (1965b) found a large decrease in percentage of males about six weeks before breeding females were recorded in his samples. Since nearly 80% of the females were gravid after that time, he suggested that the reproductive activity of the males must have been very intensive over a short period of time. Thus he presents the hypothesis that males have a critical period during the moult before mating, or during mating itself, in which their mortality rate is high.

Some seasonal variation in sex ratios can be seen in Table I. The percentage of males does not decrease until well after the breeding season has begun (first recorded in late August), and does not reach its lowest value until the final sample. Breeding occurred as a slow build-up of gravid females in the samples. This is probably a response to the relatively gradual changes in season experienced in the North Island of New Zealand. The sudden surge in reproductive activity in France (Amanieu, 1965b) may only reflect the much more drastic change in climatic conditions of Europe.

General discussion

It has been shown elsewhere (Page 16), and in the results above, that a difference exists between the two sample types. "Random" samples contained a much higher proportion of adult individuals than "nonrandom" samples. In the "random" samples the overall sex ratio favoured females, whereas there is no significant departure from a 1 : 1 sex ratio in "nonrandom" collections. Juvenile, nonbreeding, P. scaber individuals comprised only 25% of the samples taken in a "random" manner and of the adults, 58% were females.

The "random" collections do not consistently favour females; in fact, until the last two months, males were the predominant sex. It is possible that the shift to female predominance is associated with the change in reproductive status of the adult females which

occurred at that time. The existing patterns of behaviour may be modified after the female becomes gravid. For example, habitats may be selected more for their potential as breeding sites, than as places in which to feed. A differential pattern of habitat selection between gravid and nongravid adults could help explain the results obtained in the study.

In "random" samples there appears to be a correlation between the proportion of adult gravid females, and the male to female sex ratio. Where there is a high proportion of gravid individuals, such as in the last two samples, the sex ratio tends to favour the female. This does not apply to the "nonrandom" samples in which the sex ratio of adults at no time favours females. There is a need for further investigation into the causes of this apparent phenomenon, since the ratios of the sexes in P. scaber populations seem to depend upon the site of collection, and the time of year when the sample is taken. Closer scrutiny of other terrestrial isopod species may reveal similar patterns.

5.4 Conclusions

The contention of Vandel (1925) that populations of terrestrial isopods contain more females than males, has received further support from this study. However, the differences present between the two types of sampling, and the sex ratio variation with season and between age classes, suggests that apparently simple results may have a complex interpretation.

It appears that there is a differential mortality rate between the sexes, with the females becoming less viable as they grow older. The mortality increase may operate during the period of gravidity, but does not appear to act in the form of a higher rate of water loss from the brood pouch. Observations suggest that the

ecdyses after brood release may be an important cause of such mortality.

6. REPRODUCTIVE BIOLOGY

6.1 Introduction

The reproductive status of a population is reflected by its age structure. In the following section, the factors which give a population its "reproductive status" are discussed. The potential production of young and the realised natality are considered, and related to the survival of laboratory and field populations.

6.2 The breeding season

Results

The data in this one-year study are insufficient to fully describe the timing and length of the breeding season. However, twice monthly collections of P. scaber have been made at Massey University from early September, 1969 to January, 1971, by Dr R.A. Fordham. These samples have been made available for use in the present study. Although these samples were not collected specifically to give information on the dynamics of the local population, they have been used in conjunction with the author's data to estimate the periodicity of the breeding cycle.

Major climatic factors from April, 1969 through to December, 1971 are shown in Fig. 7, as is the timing of successive breeding cycles. Gravid females were present in the first sample of 1969 (September 9), and in the last in late March, 1970.

In the following season females carrying young were present between late August and early March. In the 1971-72 season, the first gravid females were found in a sample taken on August 12, 1971. The end of this season can not be defined since sampling finished in December. Each year therefore, the season has begun in spring (late

Fig. 7. Breeding periodicity of P. scaber in relation to rainfall, temperature, and daylength. Weather data were taken from the "Ministry of Transport", Meteorological Observations, for D.S.I.R. Grasslands, Palmerston North, beginning August, 1969. Daylength data were obtained from the "Tide Tables" of the N.Z. Nautical Almanac, 1971.

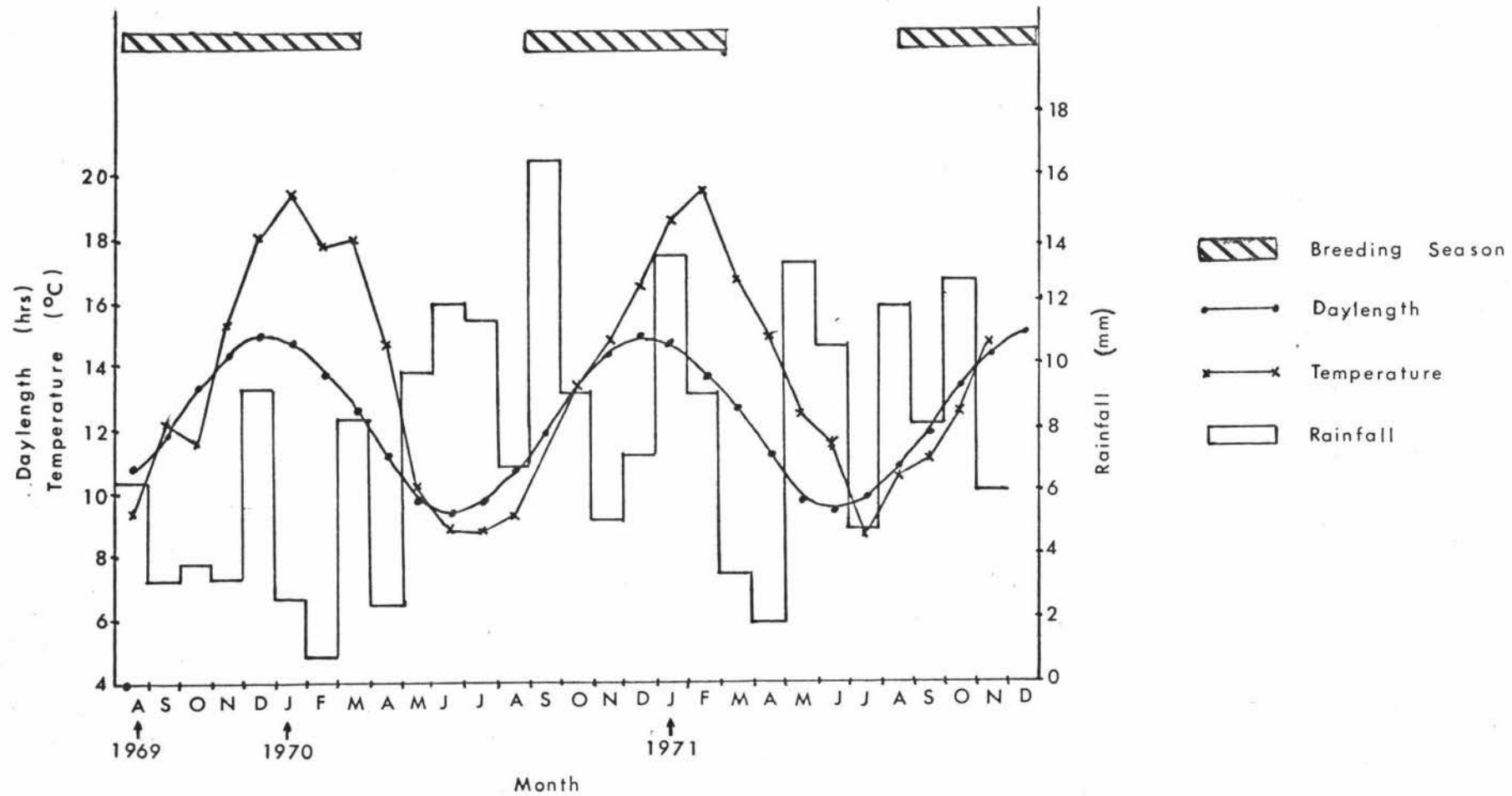

August) and has extended for about 7 months through summer to March. There is no apparent correlation with precipitation, since clearly defined patterns of rainfall do not exist. However, temperature and daylength values have been similar at the initiation of each cycle - between 10 - 11°C, and 11 hours daylight, respectively. Similarly, the season has terminated after the hottest part of summer (at about 17°C) when the photoperiod has been about 12 - 13 hours.

The incidence of gravid females in the samples is shown in Tables IV and V, which reflect the increasing proportion of gravid mature females from the onset of breeding in spring. However, striking differences appear between the sample types. Ninety per cent of the mature females collected in "random" samples in December were gravid, whereas 52% of the comparable "nonrandom" females were gravid.

Over the first five months of the 1971-72 breeding season, the mean size of gravid females decreased steadily in both "random" and "nonrandom" samples (Tables IV and V). The smallest gravid females were found in December. Sexual maturity was considered to be attained when the head width was 55 m.u. (see Growth section, Page 42); this is the head width 12 months after release from the brood pouch. Only four gravid females which were smaller than this were found in the collections, and these were in December. These results suggest that breeding does not occur until after the animals have reached an age of one year, that is, the middle of the first breeding period after their birth.

Discussion

The breeding season

Most of the terrestrial isopods, including *P. scaber*, have been found to have a seasonal pattern of breeding (Collinge, 1915; Heeley, 1941; Hatchett, 1947; Brereton, 1956; Amanieu, 1965b).

TABLE IV

Reproductive status of female P. scaber collected in "random" samples.
 Immature individuals have a head width (H.W.) of less than or equal to
 54 m.u. Mature animals are larger than this.

Date	Total ♀ ♀ taken	Immature Total	Mature			Mean H.W.
			Total	Nongravid %	Gravid %	
April 1, 15.	171	79	92	100	0	-
April 29, May 13.	50	15	35	100	0	-
June 3, 17.	132	18	114	100	0	-
July 1.	18	0	18	100	0	-
July 27, Aug. 12.	138	26	112	97	3	81.3
Aug. 26, Sept. 9.	32	8	24	83	17	88.8
Sept. 23, Oct. 7.	48	7	41	46	54	79.5
Oct. 21, Nov. 4.	218	68	150	45	55	75.1
Nov. 18, Dec. 2.	413	60	353	12	88	69.9
Dec. 16.	1032	82	950	10	90	66.2

TABLE V

Reproductive status of female *P. scaber* collected in "nonrandom" samples.

Immature individuals have a head width (H.W.) less than or equal to

54 m.u. Mature animals are larger than this.

Date	Total ♀ ♀ taken	Immature Total	Mature			Mean H.W.
			Total	Nongravid %	Gravid %	
April 8.	180	127	53	100	0	-
May 6, 20.	486	386	100	100	0	-
June 10.	113	73	40	100	0	-
June 24.	424	310	114	100	0	-
July 22, Aug. 5.	553	379	156	100	0	-
Aug. 19, Sept. 2.	935	463	472	95	5	82.2
Sept. 16, 30.	652	378	274	71	29	79.7
Oct. 14, 28.	525	386	139	76	24	74.1
Nov. 11, 25.	280	97	183	59	41	67.7
Dec. 9.	194	55	139	48	52	67.2

As shown above, this also applies to a New Zealand population of P. scaber.

The length of the breeding season for P. scaber in New Zealand was 7 months. Other workers have reported for P. scaber a season lasting only 4 months, although the season in France (Amanieu, 1965b) began a month earlier than that in England (Heeley, 1941). The duration of the breeding period, and consequently the number of broods which can be produced in one season, may vary with latitude (Vandel, 1925). However, Palmerston North (41°S) which lies at latitude rather similar to the study region of Amanieu (44°N) has a breeding season which is nearly twice as long.

Climatic and environmental conditions appear to have some influence in determining the length of the breeding season. The present study showed an apparent correlation between temperature and/or daylength, and breeding. A suggestion by Miller (1938) that the A. vulgare breeding season in California was coincident with the rainy season, was not supported by the research of Paris and Pitelka (1962). These latter authors found that the reproductive period covered the season of greatest daylength, with onset and termination of breeding occurring at about 12 hours daylength. Further, there were no apparent correlations with either vegetational changes or changes in temperature. Since these relationships have not yet been clearly defined, it would be valuable to conduct further investigations along these lines.

The climatic data of Fig. 7 show that the period from August, 1969 to April, 1970 was unusually dry. The effects of this drought on the breeding in 1969 and subsequent years is unknown, although it does not appear to have influenced the timing of breeding. Sutton (1968) found that a severe summer drought caused the cessation of growth in T. pusillus pusillus so that by the following spring the

population consisted almost entirely of small juveniles. As a result of this, maturation and breeding were delayed and embryo production severely reduced. It is interesting to note that under the same conditions Ph. muscorum suffered no reduction in growth.

Age at first breeding

The results of the present study indicate that in New Zealand P. scaber may breed after reaching an age of one year, although the majority do not do so until several months later. Previous workers have presented conflicting reports as to the age when P. scaber first breed. Verhoeff (1920) showed that females of that species were capable of producing two broods per year, in the summer following their birth - at an age of 9 - 12 months, while Amanieu (1965b) found that females bred after attaining a length of about 7 mm. Seven millimetres is equivalent to one year's growth based on the results of this study. Conversely, Heeley (1941) recorded first broods only after the animal had twice wintered.

Another study (Amouriq, 1967) using laboratory cultures of P. scaber, found that females could breed 105 days after being released from the brood pouch. This result suggests that the age at first breeding is a function of the environmental pressures exerted from birth to maturity. These "pressures" would be factors which could limit growth and sexual development; for example, quality and quantity of food, temperature, and possibly photoperiod. An ecological study on Porcellio in a tropical region where temperature and photoperiod are relatively constant throughout the year might provide an interesting contrast to the results above.

Size of gravid females

It has been previously noted (Tables IV and V) that the head width of gravid P. scaber females decreased towards the middle of

the breeding season. The small individuals taken in December had head widths which corresponded to those of one-year-old slaters. Similarly, in A. vulgare there was a marked tendency towards reduction in size of the gravid females towards the end of the breeding season (Paris and Pitelka, 1962). The first females to breed were the older generations, with one year old females reproducing by mid season. This suggests that the situation for P. scaber in New Zealand is the same as that for A. vulgare in California.

Proportion of gravid females

An interesting difference between the two types of samples is shown in Tables IV and V. The proportion of gravid females is much lower in the "nonrandom" samples than in the "random" collections, and in the final two samples, the difference was as high as 40%. The possible reasons for this have been discussed elsewhere (see page 25).

6.3 Fecundity and fertility

In this section, fecundity is taken to represent the total number of ova produced, whereas fertility refers to the number of ova, embryos, larvae or young, which are viable at each developmental stage. Mortality, in this instance, is equivalent to the number of infertile or nonviable units of these stages.

Results

The data of Fig. 8 were recorded from direct counting of the brood pouch contents of 131 P. scaber. There is a progressive increase in number of ova with increasing adult size. This relationship can be described by the linear regression equation, $y_1 = 1.29x - 68.79$, in which y_1 is the number of ova in the pouch and x is the head width of the female (m.u.). Although a slightly curvilinear component is suggested by the distribution of the data, it has a high

Fig. 8. The relation of number of (i) ova, (ii) larvae, and (iii) young, to head width (m.u.) of the P. scaber female. Linear regression equations for each set of data are:-

$$(i) \quad y_1 = 1.3x - 68.8$$

$$(ii) \quad y_2 = 0.9x - 37.6$$

$$(iii) \quad y_3 = 0.4x - 1.0$$

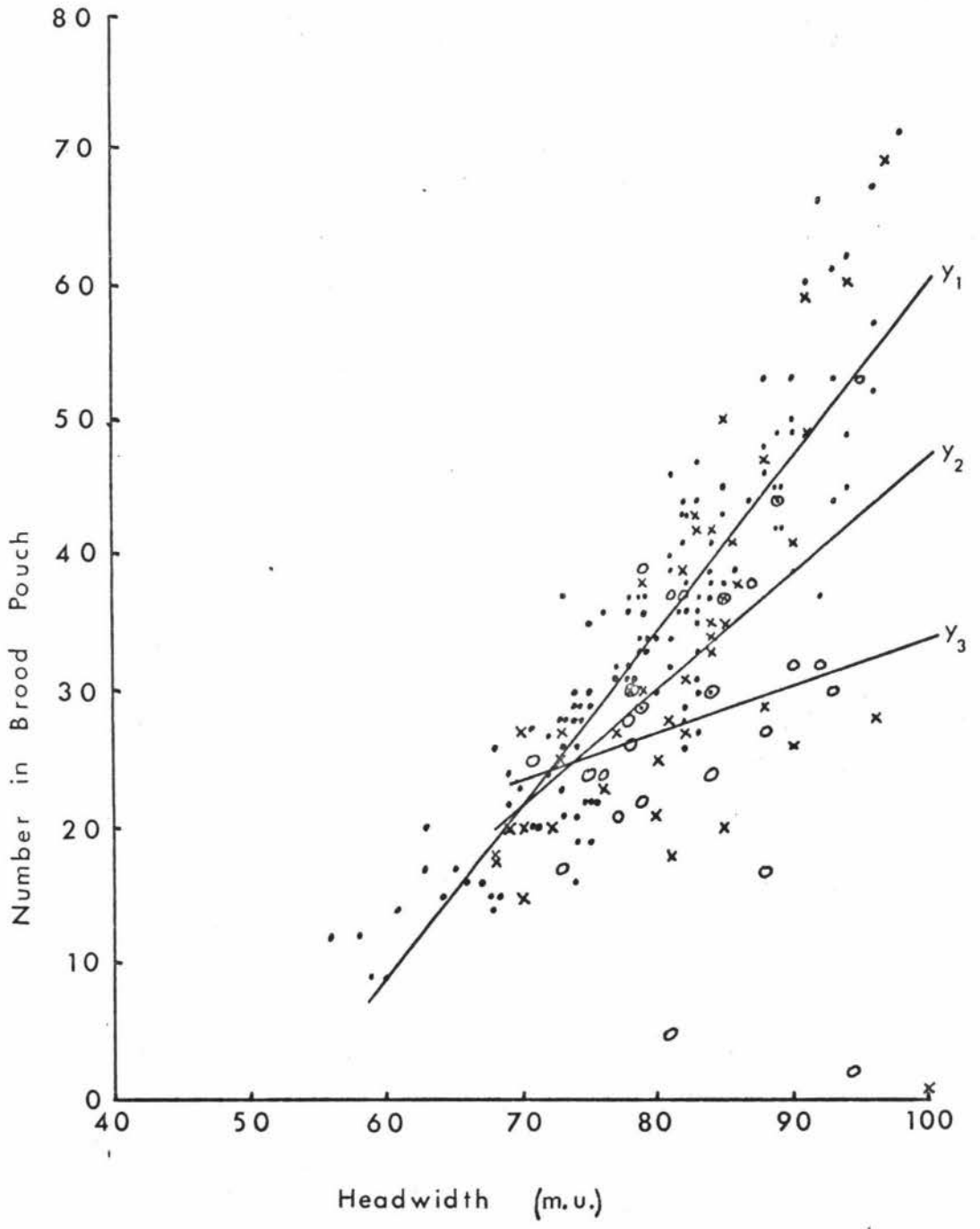

correlation ($r = 0.90$) with the regression line.

Brood size varied from 9 ova in a 59 m.u. female to the exceptional 114 (105 larvae, plus 9 morbid ova) in an individual with head width of 117 m.u. (not shown in Fig. 8). In most slaters the range was from 20 - 50 ova per brood.

An estimation of brood mortality was made by counting the brood pouch contents at different developmental stages. When ova only were present, it was not possible to readily distinguish morbid ova, but in the embryonic and larval stages, they were opaque, or yellow coloured, and lacked development. Dissection of forty-four variously sized P. scaber provided the data for the second equation, $y_2 = 0.85x - 37.6$, in which y_2 is the number of larvae per brood pouch, and x is the head width (m.u.). The data are quite variable as the low correlation (0.51) suggests.

Counts were made of the number of larvae, and the number of undeveloped ova and underdeveloped embryos. The number of morbid ova in each brood varied considerably; in several cases there were none, and in one instance the whole brood was in an advanced state of decomposition. No accurate assessment of the proportion of adults in the population which abort their complete broods has been made, but three of a group of ten gravid P. scaber kept in the laboratory in December, 1971, failed to produce any live young. The numbers of young recorded for each female ($n = 26$) from the growth cultures, have been plotted on Fig. 8 as open circles. They are described by the equation $y_3 = 0.35x - 1.0$, where y_3 is the number of young per brood, and x is the head width of the female (m.u.). A very low correlation ($r = 0.22$) is caused by the nearly total failure of two large slaters to produce any offspring, and by the better than average success of several others.

An alternative method was also used to express fertility. The mean head width of the gravid females ($n = 44$) was calculated and the number of ova for a female with mean head width was derived from the equation in Fig. 8. This value, when multiplied by 44 represented the expected number (E) of ova in the dissected adults. Two assumptions are made - that the relationship shown in Fig. 8 is valid for all P. scaber in the study area, and that no mortality had occurred in the ova at the time of counting. The larval numbers, when summed, represent the observed value (O). Thus,

$$\text{Survival (\%)} = \frac{O}{E} \times 100$$

For the animals above, $O = 1434$, and $E = 1620$, giving a survival to larval stage of 88.5%. An estimate of survival from ova to birth was obtained by treating the data from the growth study (see Page 41) in the same way. In this, O is the number of young born (736) and $E = 996$, a 73.9% survival. The observed number of young born is a conservative estimate, for although counts were made within 12 hours of birth, some animals may have died and been eaten between birth and counting.

Thus, there is a mortality of about 12% in development from ova to larval stage, and a further 14% before the young are released from the brood pouch, i.e. a combined mortality of 26% up to the free living stage. This is a mean value for the whole range of data, and does not show as the first method does, that there is a progressive increase in mortality as the head width increases (Fig. 8).

Discussion

Brood size

At all stages of development brood size in P. scaber can be quite variable. Verhoeff (1920) cited a mean value of 88 eggs per

brood, whereas Hatchett (1947) obtained a considerably smaller mean value of 24 eggs per brood (range 6 - 42). Laboratory broods of between 12 and 30 young and between 6 and 55 young (mean of 24) were counted by Collinge (1915) and Heeley (1941), respectively.

However, since a significant positive correlation between length of the body and the number of young has been demonstrated in several isopod species - C. convexus (Hatchett, 1947), A. vulgare (Paris and Pitelka, 1962), and P. scaber (Brereton, 1956) - the mean values above require further qualification to be useful. For P. scaber, Hatchett (1947) found a mean of 19 young per brood in females between 9.5 - 10.5 mm. in length, 23 per brood in females 11.0 - 12.0 mm. in length, and 40 per brood for females from 12.5 - 13.5 mm. He also showed a positive correlation between the transverse area of the body (taken across the midline), and the number of offspring in each brood.

For comparison with the values of Hatchett (1947) the three length classes above were converted to the appropriate head width values by means of the relationship shown in Fig. 11 of the growth study. The number of young for the length classes were 19, 23, and 40, respectively (Hatchett, 1947). For the equivalent head width values in the present study, the corresponding numbers of ova are 25, 38, and 51, and after allowing a 25% mortality, the values are reduced to 19, 28, and 38. These results agree closely with Hatchett's findings.

In the present study head width is clearly correlated with the number of ova produced by the gravid female, but the relationship with the numbers of larvae and of young is less clear. Sutton (1968) demonstrated that head width was positively correlated with the number of embryos contained in the brood pouch for both T. pusillus and Ph. muscorum.

Mortality in the brood pouch

The mortality rate within the brood pouch was first estimated for P. scaber by Brereton (1956). He compared the regression equations of the number of ova, and of the number of hatched young, against female length. The mean number of ova (45.9) and of young (37.8) differed significantly, the difference indicating that only 82% of the eggs deposited in the pouch survive to become live-born.

This 18% mortality before birth is considerably less than the 26% estimated in the present study. However, the latter estimate is based on counts of young up to 12 hours after birth. From birth until counting a significant number of young could have disappeared (been eaten) from the cultures, so that the 26% mortality is probably too high.

Both these values are higher than that recorded in the literature for other species of isopod. A mortality of only 0.8% has been shown for Ph. muscorum (Sutton, 1968), and 7 - 8% in A. vulgare (Paris and Pitelka, 1962). A recent study on the aquatic isopod Asellus tomalensis (Ellis, 1971), which has a similar brood size to P. scaber, recorded a 14% mortality rate. However, these three figures are for mortality from the egg stage to the larval stage and do not consider the postlarval period up to birth. In this latter period the mortality was slightly higher than for the first stages. It is likely that the estimates of mortality in the literature are considerably less than the mortality recorded in the field.

No direct relationship appears to exist between mortality and the size of the brood produced among different species of isopod. Ph. muscorum has small broods (average size = 13, Heeley, 1941), and has an almost negligible death rate up to the larval period of development. On the other hand, A. vulgare has large broods (average size = 113, Heeley, 1941; and 40 - 44, Paris and Pitelka, 1962) yet

has a relatively low mortality rate of 7 - 8%. As discussed above, these estimates may be too low. The mean brood size of all *P. scaber* females collected in the present study was 20 - 22 eggs per female, and the mortality was up to 26%.

However, Fig. 8 shows that the mortality rate actually increases with increasing size of the brood. The death rate is lower at small head widths than for larger animals. This may partly be an artifact of the data; very few individuals with a head width of less than 75 m.u. were cultured for their broods. But the trend is evident in the equation describing data from the larval stage as well. This suggests that some sort of "density dependent" limiting mechanism operates to regulate the number of young produced.

Mortality of brood pouch contents can arise from several causes. Some of the eggs released into the pouch may be infertile; others may not have been fertilised at the time of mating. Instances of spermatazoa being stored for over a year in the female, and then being used to fertilise the next season's eggs, have been reported (Collinge, 1915). In these cases, the spermatazoa may have a lower viability. Other problems may prevent successful rearing of the young in the brood pouch. Some of the larvae will die at, or very soon after, birth because their development has been slower than the bulk of the brood. As the eggs follow the developmental sequence through to larvae the mass will increase considerably. A certain amount of expansion of the oostegites (the flaps surrounding the brood and forming the brood pouch) can create more space for the young as they grow, but this is not unlimited and will depend on the size of the female. It is possible that this acts in some way (for example, by compression) to limit the survival of the offspring contained in the pouch. The nutrient supply provided by the cotyledons inside the pouch is possibly another limiting resource.

6.4 Natality

Description of the dynamics of a population requires an estimate of the reproductive effort expended annually by the females in that population. This estimate can also assist in the calculation of survival and replacement within the population.

In this study, the reproductive effort has been related to an arbitrarily chosen population of 1000 individuals. The age structure distribution of Figs. 4 and 5 can be used to find the contribution which each generation makes to the population of 1000 animals. Individuals from generation 0 of the October/November sample comprise 63.1% of the total slaters taken. Generation 1, and older animals, comprise a further 36.9%. Thus, in the population, 631 slaters will be from generation 0, and 369 will be from older generations. Of the older animals, 292 are from generation 1.

The sex ratio data for the October/November sample shows that 48.5% of all slaters taken are female. In the population above, 485 will be female.

In Britain, Heeley (1941) has shown that over 80% of the adult P. scaber females breed once, and about 15% breed two times in a year. Brereton (1956) also found a bimodal breeding pattern in P. scaber. A small peak in May was followed by a large peak in July, when nearly 100% of the females were gravid. In the present study, sampling did not continue over a complete breeding season, so the frequency with which slaters breed in New Zealand is not known. However, 76% of the females collected in the final December sample were gravid. Since the breeding season lasts until March it is likely that most females breed once, and some may breed twice. An 80% level of breeding will therefore be used in estimating natalility; this is considered by the author to be conservative.

Over 1500 gravid females were measured up to December, 1971. These had a mean head width of 68.7 m.u. The number of ova characteristic for this head size is 20.5 (from the equation, $y = 1.3x - 68.8$, in Fig. 8).

In the population above, if 80% of the females breed once in a year, there will be 388 gravid slaters each carrying an average of 20.5 ova. A total egg production of 7954 will therefore be achieved. Since mortality prior to birth is about 25%, approximately 6000 young will be produced from every population of 1000 individuals.

Brereton (1956) has estimated the natality for a P. scaber population in Britain as being about a 6-fold increase per breeding season, if there was no mortality in the young after birth. This agrees closely with the value obtained in the present study, but is less than the 8-fold increase of Paris and Pitelka (1962) for A. vulgare. Heeley (1941) has shown that P. scaber is a less fecund species than A. vulgare. This is further supported by the data above.

6.5 Mortality

As a part of the study, the laboratory cultures reared from the broods of gravid individuals, were counted each week. This data has been expressed in a mortality graph (Fig. 9) which shows the percentage survival with time. A large proportion of young died in the first five weeks after birth, and the mean number of young per brood fell from 29 to 15 in this period. After 10 weeks the decline slowed, and in subsequent weeks until the experiment concluded, the mortality rate remained low. By the end of the experiment, only 11% of the original young were alive.

In the natality section it was estimated that the population of 1000 individuals would produce 6000 young in a breeding season. The population has about 630 year old individuals, so, on this basis,

Fig. 9. Mortality of laboratory reared P. scaber.

Graph of survival (%) versus age (weeks). The value of 100% is equivalent to 665 young, from a total of 22 broods.

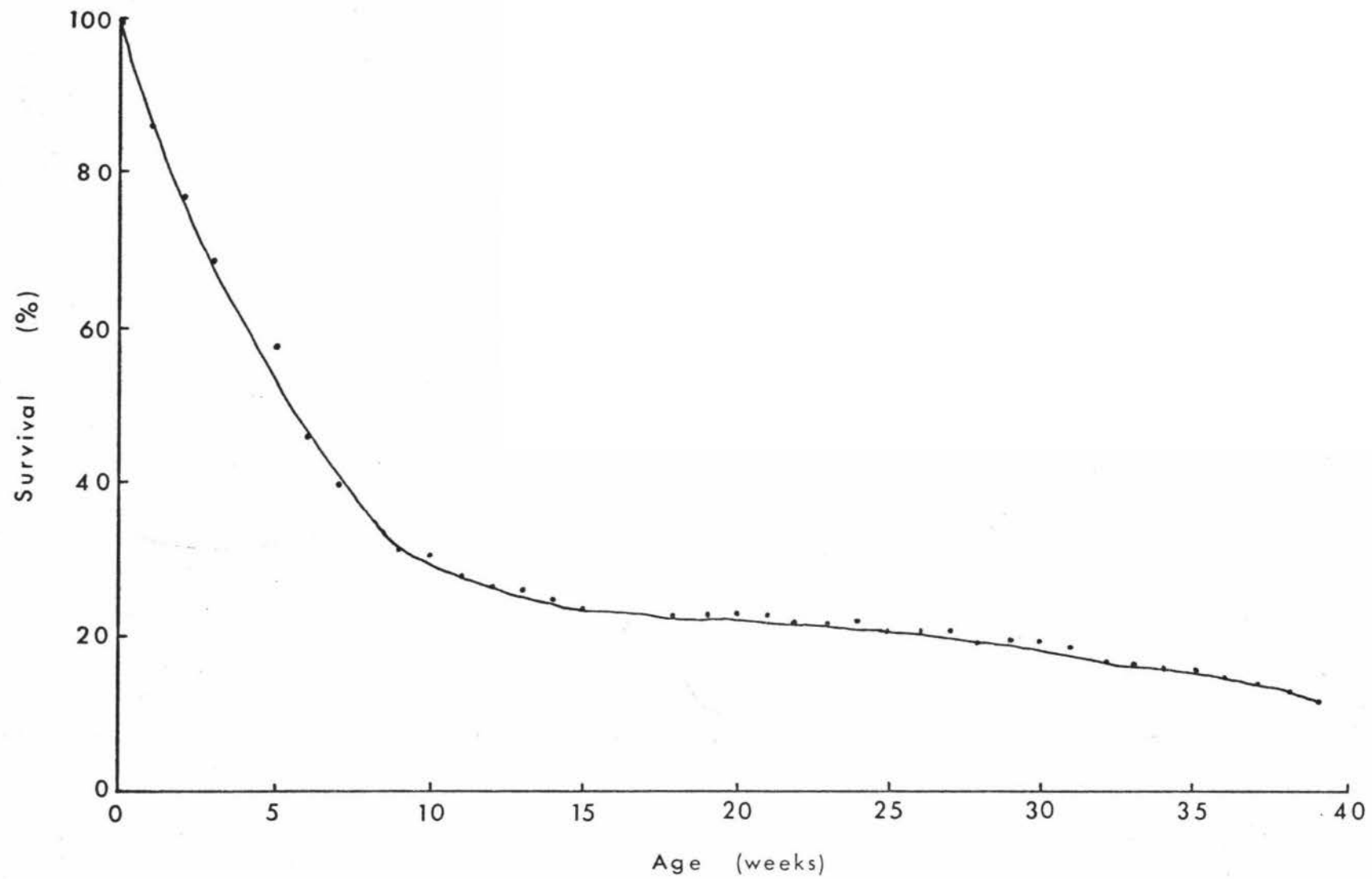

survival at the end of the first year = $630/6000 = 10.5\%$. This value is very similar to that observed in the laboratory reared broods. The close agreement of these results suggests that the 11% estimate of natality was reasonably accurate.

6.6 Conclusions

The P. scaber population in this study had a breeding season which lasted for seven months. Breeding began at about the same time each year in the last three years, suggesting a correlation with temperature and/or daylength.

It is not known whether P. scaber in New Zealand has a bimodal pattern of breeding, because the sampling for this study concluded when breeding was at a maximum value. Sexual maturity is attained after one year of life; thus it is the older larger animals which breed in the first part of the breeding season. The proportion of young slaters increases as the season progresses.

Fecundity increases in proportion to the size of the individual. Small slaters have few ova; large slaters have many. A relatively high production of eggs is offset by the high mortality which occurs in the brood pouch. There is, however, a 6-fold increase in natality at each breeding season. Laboratory and field studies have shown that only about 11% of the young which are born, survive to become one year old. Since this estimate of natality is conservative, it suggests that the P. scaber population is undergoing a slight decrease in numbers, or is stationary.

7. GROWTH OF P. SCABER

7.1 Laboratory cultures

A growth study was begun in March, 1971, in conjunction with the weekly sampling. Individuals of known age were reared in isolated broods, and measured at weekly intervals. The results obtained from the broods which survived for at least five weeks ($n = 23$) are shown in Fig. 10. Although broods were released on different days of the week, they were all measured each Thursday. This means that the points in Fig. 10 do not truly represent weekly growth increments, but rather, the mean increase up to and including the seven days prior to measurement.

In order to demonstrate the extremes of size attained by different broods, the cultures which increased at the fastest and slowest rates, are plotted, as well as the mean rate of growth. The "staircase" effect of moulting on increase in rate of growth is especially noticeable in the maximum curve, and in the early developmental period of the mean curve.

An early period of rapid growth is followed by a slower phase from about 15 weeks of age. After about 25 weeks, this increased again until the cessation of measurements. The slower growth period corresponds to the coldest part of the year (June, July, August). The cultures were kept at about 2°C above the mean ambient temperature.

The final point on the graph comes from measurements on only 17 individuals (compared with 78 for the previous value) and may be less reliable because of this. However, it follows the trend set by the other values.

Another small survey on the growth of newly released young (4 broods) gave the results shown by the line drawn to 15 weeks of age.

Fig. 10. Increase in head width among P. scaber individuals, showing growth of animals of maximum and minimum size, as well as mean growth of all individuals studied.

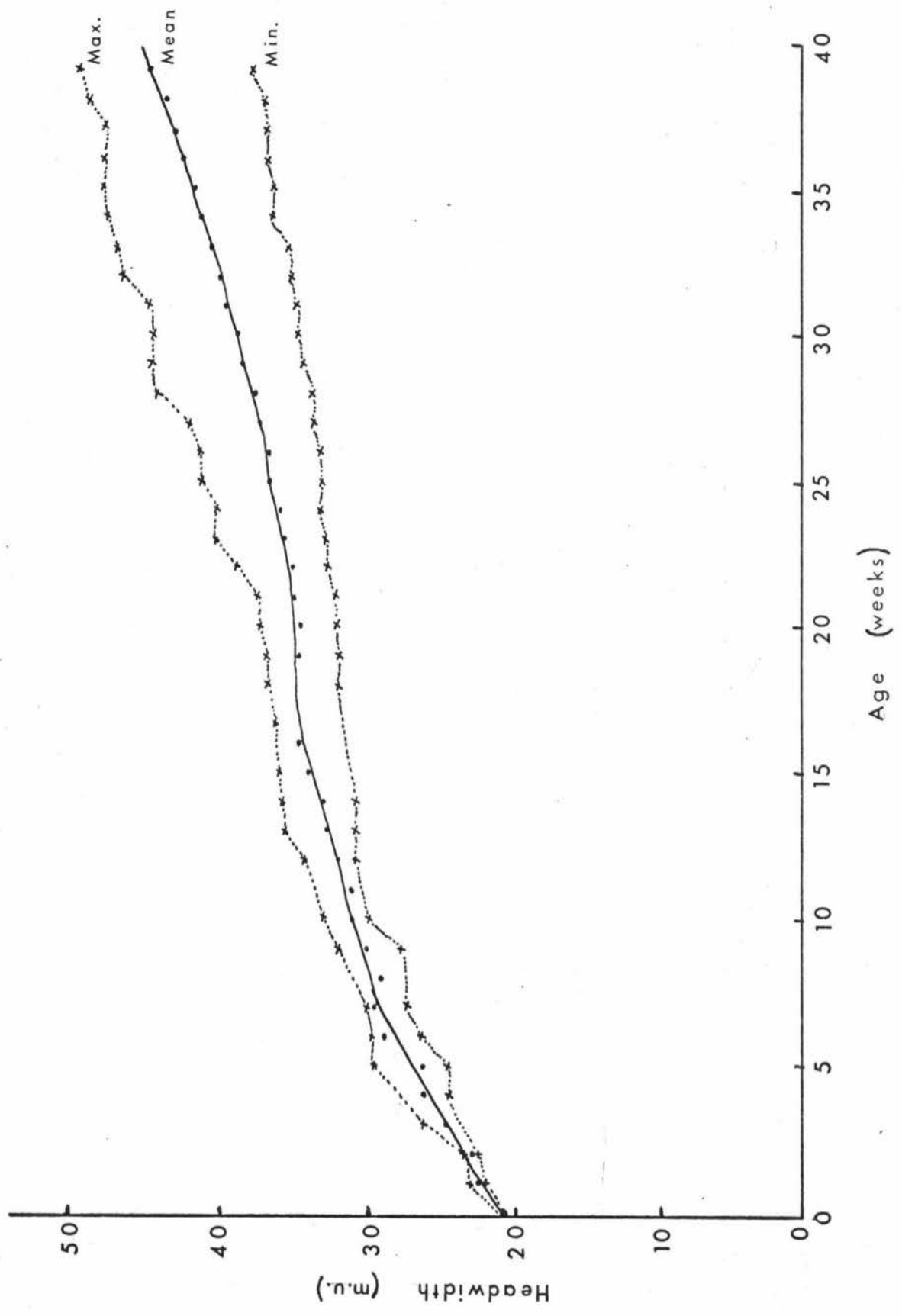

These were born in October, 1971, and measured weekly. The growth rates of both sets of young (early and late broods) are nearly identical.

When extrapolated, the mean growth curve intersects the one year's growth line (52 weeks) between 53 - 57 m.u. head width. In the field data, when the new seasons young first appeared, a break in the frequency distribution occurred between 52 - 60 m.u. The head width attained after one year has therefore been taken as 55 m.u.

Growth rates of older individuals were also monitored, although not as intensively as those of the young. The results of this investigation have been expressed in terms of the mean time taken, in days, to achieve a 1 m.u. head width increase. For the individuals up to 55 m.u. head width, the time taken was 17 days; for generation 1 it was 34 days; generation 2 (up to 88 m.u.) individuals took 26 days; the older slaters took 42 days to increase 1 m.u. These results give some indication that the younger animals increase their head size at a more rapid rate than older generations.

7.2 Effects of density

Results

An experiment to investigate the effects of crowding and of size of container on mean rate of growth of a brood was established when the young were released from the brood pouch. Six gravid females had been placed in large Petri dishes (Area = 63.5 cm²), and twenty-one females were isolated in smaller dishes (Area = 12.5 cm²). The growth results of the fifteen broods which survived until measurements ceased are shown in Table VI.

The young in large dishes have a higher mean head width after 39 weeks of growth than their small dish counterparts; 47.9 m.u. and

TABLE VIEffects of density and container size on growth of P. scaber

Number	Initial number of young	Number surviving to 39 weeks	Mean Head Width at 39 weeks	Petri dish area
1	26	3	45.0	63.5 cm ²
2	53	3	51.0	"
3	25	7	49.7	"
4	37	1	46.0	"
5	44	1	48.0	"
Mean	37.0	5	47.9	
6	37	20	37.6	12.5 cm ²
7	32	4	45.5	"
8	21	6	43.2	"
9	17	8	40.5	"
10	17	6	41.2	"
11	22	2	49.5	"
12	39	1	46.0	"
13	27	5	44.2	"
14	24	2	42.0	"
15	24	3	39.1	"
Mean	26.0	5.7	42.8	

42.8 m.u. respectively. For each dish size, the range of head width values is variable. Large dishes only vary by 6 m.u., whereas the smaller containers have a range which is double this. Of interest too is the very low head width value attained by the most crowded brood. This small dish culture, which had 37 individuals initially, still had, after 27 weeks, a total of 30 young. Even at the end of 39 weeks, 20 young remained alive. The growth rate of brood 15 is also very low. This had a relatively high number of young (14) until nine were inadvertently lost in the 30th week.

In general, the rate of growth of slater broods in large dishes has been more rapid than the rate of those young kept in small containers.

There is a tendency for the most dense broods within the small dish group, to have the slowest rates of growth. This is difficult to quantify since the number of live young has varied over the last 30 weeks. No correlation of growth rate with initial size of brood appears to exist for these data.

Discussion

A general decline in growth rate has been demonstrated in the brood cultures which had the least "living space". Density, in terms of individuals per unit area, has been shown in the literature, to have an effect on the rate of growth of cultured isopods. Amouriq (1967) recorded the daily increases in weight of P. scaber isolates, and compared their growth rates with those individuals grouped in "fives" and "tens" where all animals were kept in dishes with a surface area of 56 cm^2 . He found that at 90, 120, and 150 days, the isolates were heavier than the "tens" group individuals. The surface area of 56 cm^2 was insufficient for normal living; it produced an effect of crowding. The decrease in the rate at which individuals grouped in

"fives" increased their weight (compared with the isolates) was shown to be offset by a stimulating effect beginning at 90 days of age. From 90 to 120 days there was no significant difference in mean weight of the isolates and the "fives". Amouriq interpreted this as being evidence of a subsocial phenomenon which facilitated a weight increase in the young. After 90 days there was no difference between the "fives" and "tens".

Mocquard (1968) has reinforced the theory of subsocial facilitation of feeding, in groups of P. dilatatus. He defined two periods of growth - one in which weight increases were caused by water uptake about the moult, and another where dry weight increased. In grouped animals, the latter period was more accelerated and more efficient than in the isolated individuals. A possible interpretation of the results of cultures 3 and 4 from Table VI is that the facilitation of feeding by the young of culture 3 over the last 30 weeks has contributed to their larger size. Although all animals of culture 3 have head widths greater than 47 m.u., the difference above can not be tested statistically. The results from the smaller containers can not be regarded as being due to subsocial effects.

7.3 Effects of food quality

An interesting feature of Amouriq's 1967 work is that each of the individuals from his cultures of five slaters weighed 27 mg. after 90 days of life. In the present study after the same time, the young weighed only about 2 mg.; equivalent to 30 - 34 m.u. head width. A 27 mg. animal has a head width of 70 m.u. (See Fig. 13.) The young in the present study increased their weight to nearly 3 mg. after 150 days. Isolated slaters of Amouriq weighed 72 mg. at an age of 150 days.

There are several possible causes for this difference. Firstly, the conditions of culturing may have differed. In fact, Amouriq fed his cultures on the shoots and roots of embryonic corn, whereas I fed my broods on overwintered poplar leaves. The temperature conditions which Amouriq's cultures experienced were not mentioned. The present study used a variable temperature regime, about 2°C above ambient. In addition, the relationship of weight to head width shown in Fig. 13 may not apply to Amouriq's animals, since it contains only one slater with a head width more than 100 m.u. wide.

7.4 Measurement of size

Results

In the survey of literature undertaken before this study commenced, it was found that most workers had used body length as their size measurement. So that the results of this and other studies could be compared, several different size measurements were obtained from each of 100 freshly killed P. scaber individuals. The results are expressed in Figs. 11, 12, and 13.

Figure 11 shows that body length and head width are related in a linear fashion, and that size increments measured in one dimension can be converted into units of the other. The regression of body length against head width is $y_x = 0.15x - 1.33$, in which y is body length (mm.), and x is head width (m.u.). There is a high correlation ($r = 0.97$) of the data with the regression line.

Figure 12, based on head width and body width, shows that these parameters are also related linearly. The regression line $y_x = 0.06x - 0.72$, is highly correlated with the data.

Data from Fig. 13 has come from two sources. The fresh weight measurements ($n = 75$) were made at the same time as the measure-

Fig. 11. The relation of body length to head width,
in 100 P. scaber individuals. The linear
regression equation describing the relationship
is: $y = 0.15x - 1.33$

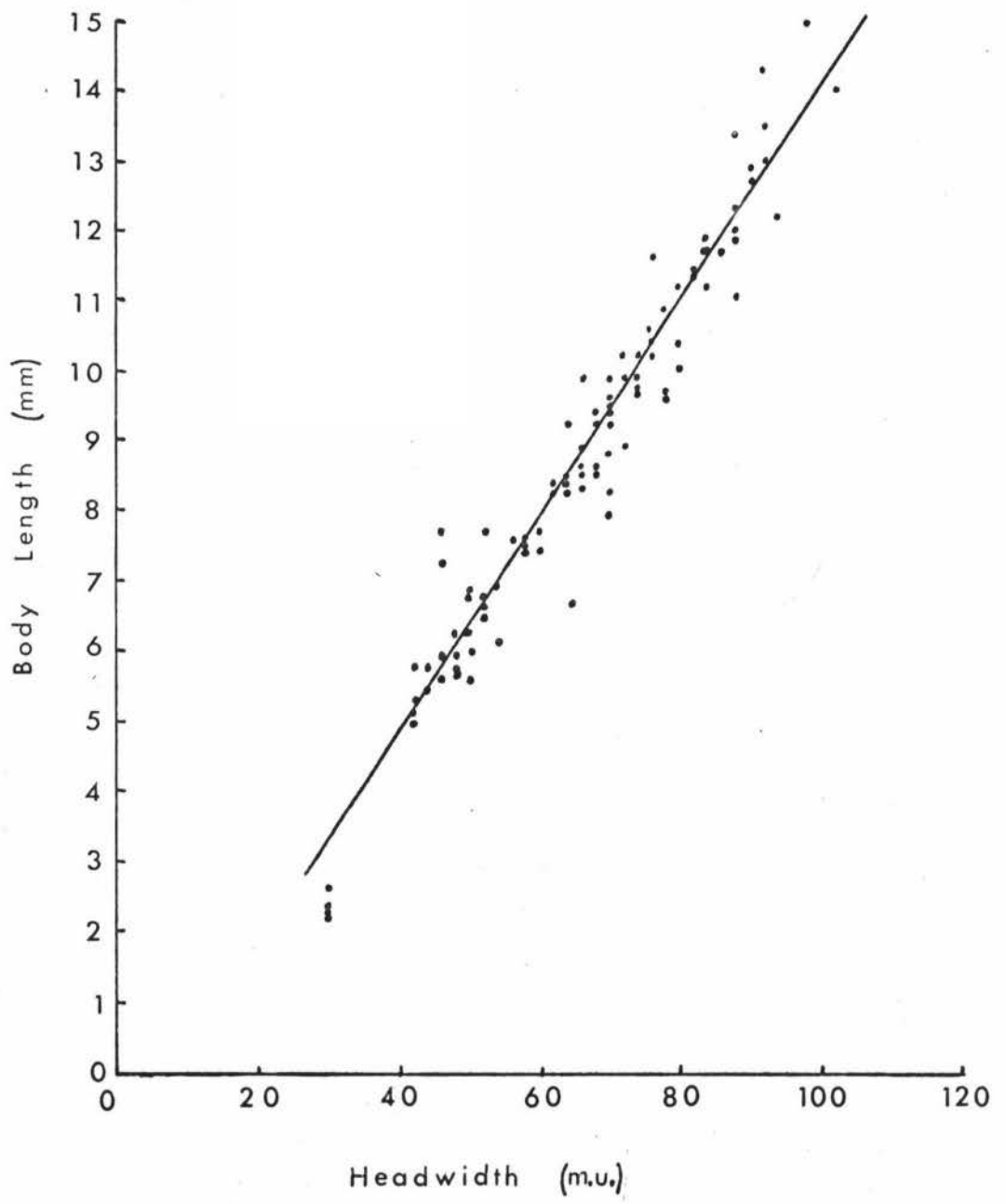

Fig. 12. The relation of body width to head width,
in 100 P. scaber individuals. The linear
regression equation $y = 0.06x - 0.72$,
describes the relationship.

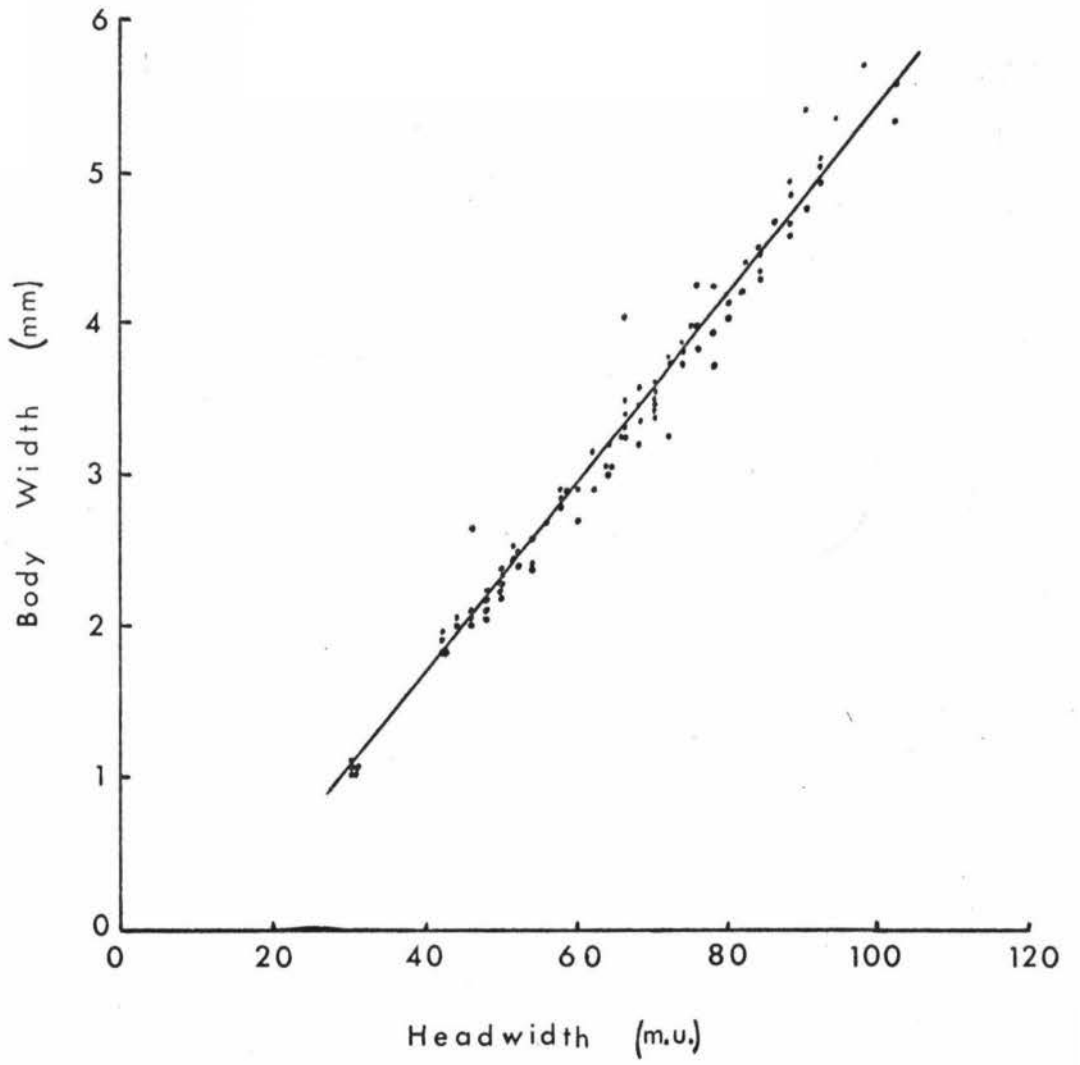
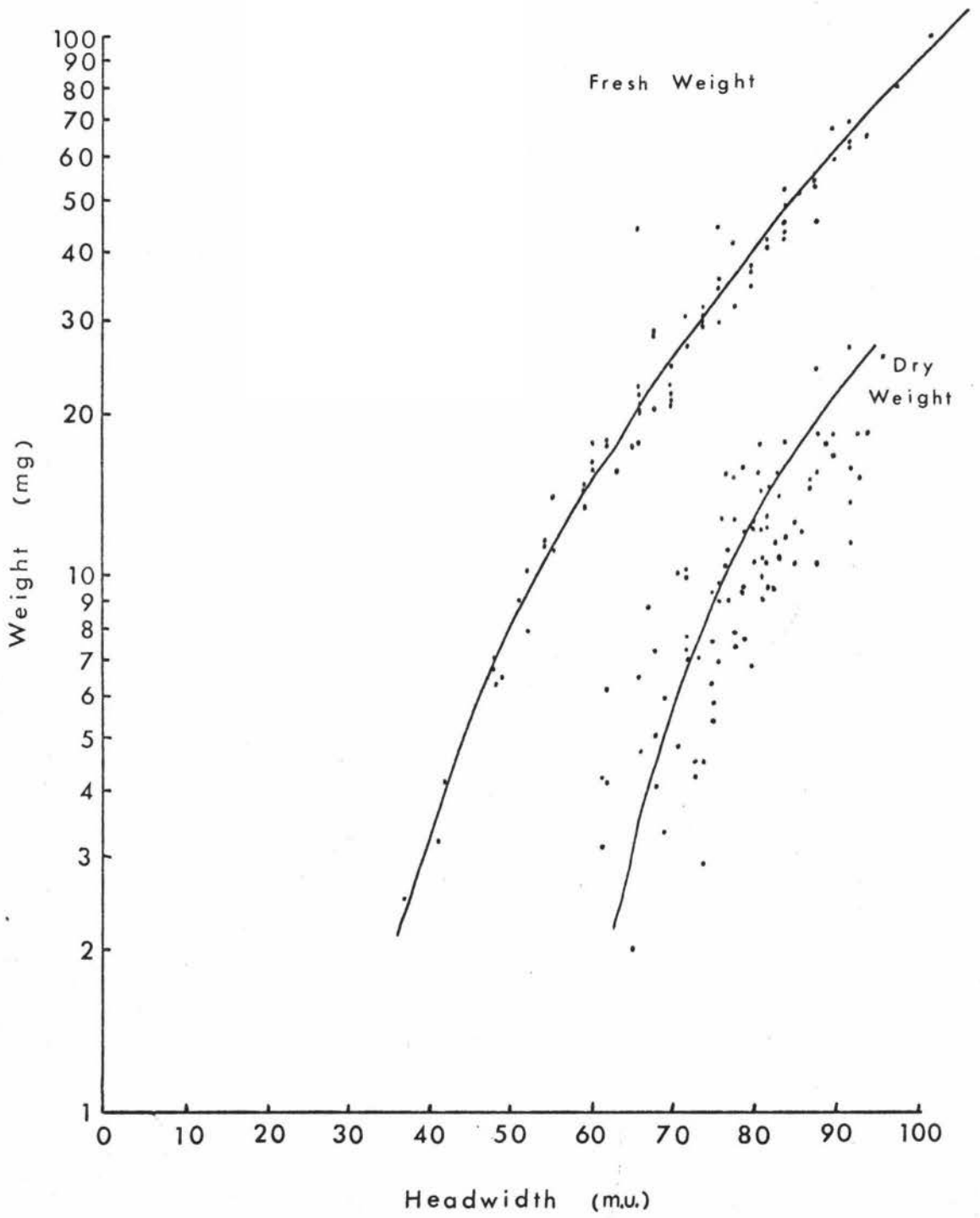

Fig. 13. The relation of (i) fresh weight, and (ii) dry weight, to head width in P. scaber.



ments of Figs. 11 and 12, whereas the dry weight values ($n = 93$) were used in the measurement of calcium (see later). Both sets of data, related to head width, have been shown on semi-logarithmic paper. Although the dry weight values are considerably more variable than their fresh weight counterparts, a difference of about $\frac{2}{3}$ the fresh weight value is maintained for most of the size range between the two lines fitted by eye.

Discussion

Several parameters may be used to measure the size in terrestrial isopods. Head width, and body width would give the most accurate results because they are both "hard parts" of the animal. Length can be accurately assessed if a standard pre-measuring procedure is followed, although its use as an indicator of live-animal growth is inherently less accurate than, say, head width.

The fairly constant relationship between fresh weight and head width shows that this too can be used as an index of size or of growth. The accuracy of this method decreases rapidly with decreasing size of the animal unless special conditions of weighing are used. The same disadvantage applies to dried individuals, except that the limitation operates at a much larger size. Weighing of several animals together can help overcome this problem.

It is interesting to note that Sutton (1968) reported that the dry weight of both Tr. pusillus pusillus and Ph. muscorum was $\frac{1}{3}$ of the live weight. This is the same as the value found for P. scaber in this study.

7.5 Conclusions

Porcellio scaber, when reared in the laboratory, maintained a rate of growth which gave a head width of approximately 55 m.u., one

year after birth. Factors such as crowding, food quality, and temperature may have affected the growth rate, even though the results agreed closely with the values obtained in the field study.

Head width, body width, and body length are linearly related measurements of size. Fresh weight appears to be exponentially related to head width in individuals older than one year of age.

8. MEASUREMENT OF CALCIUM

8.1 Introduction

Recent work on the feeding ecology of isopods and related species, has done much to elucidate the community function of these animals. Humifacative functions (Gere, 1962), isopod herbivory (Paris and Sikora, 1965), copper metabolism (Wieser, 1966), and nitrogen excretion (Wieser and Schweizer, 1970), are some aspects which have been investigated. This study attempts to define the relationship between body size and weight, and calcium content of P. scaber individuals. The position of P. scaber in the community as a calcium reservoir will also be discussed.

8.2 Results

The data presented in Fig. 14 were obtained from analyses of the calcium content of 95 nongravid adult P. scaber. It is highly correlated ($r = 0.90$) with the calculated linear regression line, $y_x = 4.4x - 243.7$, where y_x is the amount of calcium (ppm), and x is the slater head width (m.u.). The amounts of calcium present in 18 gravid adult P. scaber are shown by circles in Fig. 14.

A linear relationship also exists between the amount of calcium, and the dry weight of the individual (Fig. 15). The regression line, $y_x = 6.3x + 34.0$, where y_x is the amount of calcium (ppm) and x is the dry weight (mg.) of the slater, has a correlation coefficient of 0.77. As before, the calcium content of 18 gravid females is represented by circles.

The actual weight of calcium present in any analysis can be calculated.

$$\text{Calcium per slater (mg.)} = \frac{\text{amount of calcium (ppm)}}{\text{dry weight (mg.)}}$$

Fig. 14. The relation between amount of calcium (ppm.) and head width, in 18 gravid and 95 nongravid P. scaber individuals. The linear regression equation for the nongravid slaters is:

$$y = 4.4x - 243.7$$

The gravid individuals are shown by circles on the graph.

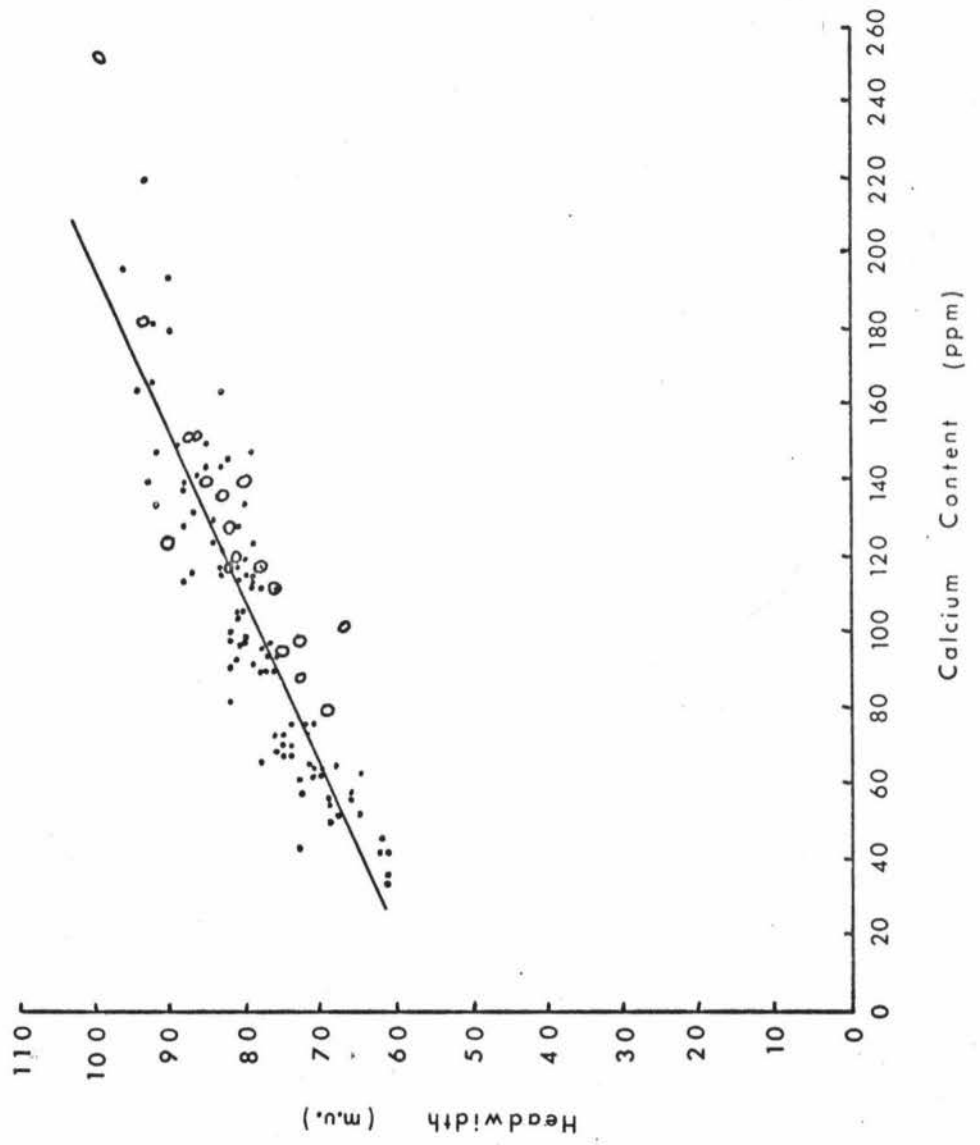
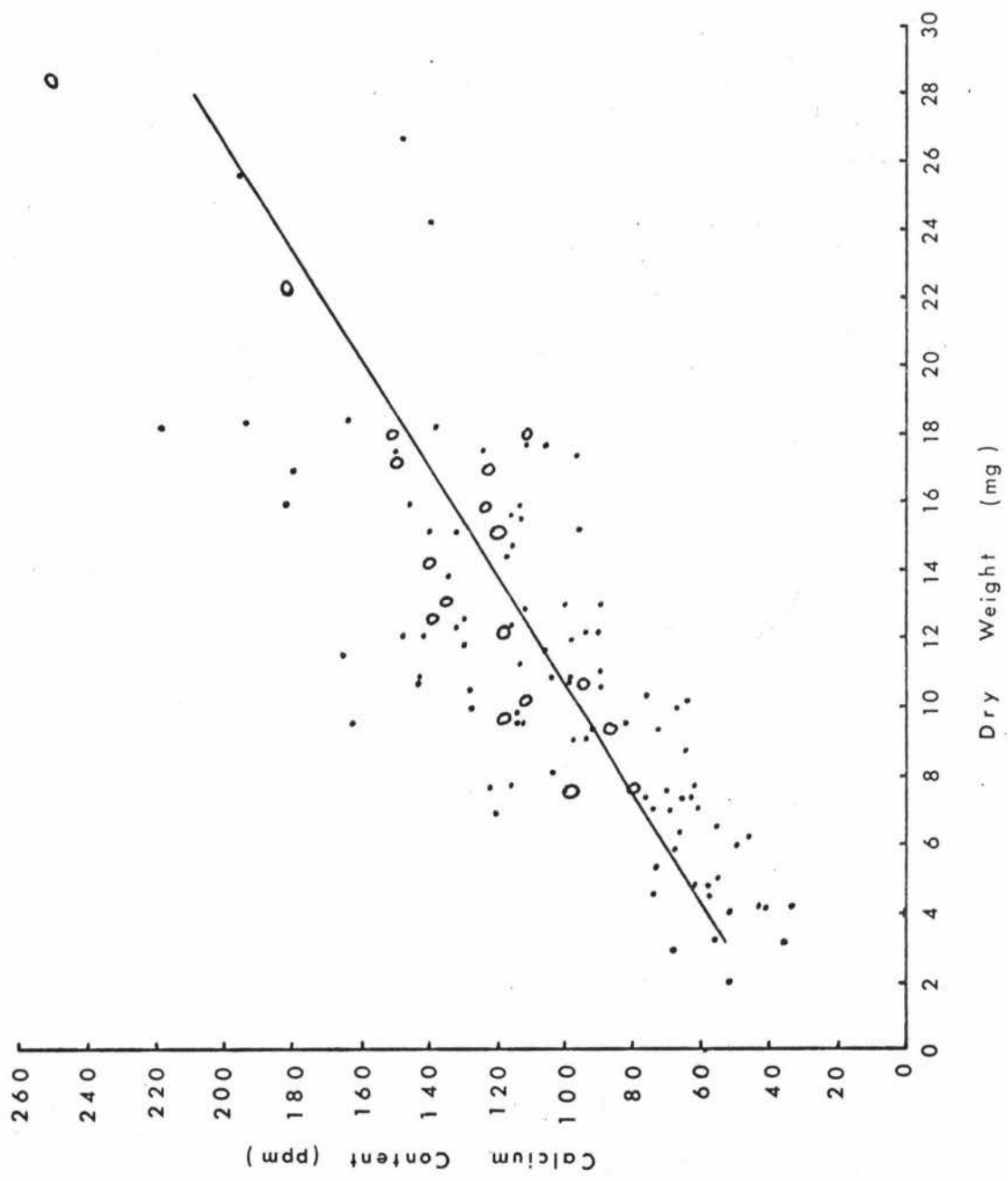

Fig. 15. The relation between amount of calcium (ppm.) and dry weight (mg.), in 18 gravid and 95 non-gravid P. scaber individuals. The linear regression equation for nongravid slaters is:

$$y = 6.3x + 34.0$$

The gravid animals are shown by circles on the graph.



A range of 16 - 26% calcium by dry weight was obtained for the data of Fig. 15.

The rate of consumption of overwintered poplar leaves was recorded in 8 sets of P. scaber in the laboratory. Each set, containing two P. scaber paired for size, was kept in darkness for six days, at a temperature of 17°C. The animals were housed in 9 cm. diameter Petri dishes, with humidity maintained by the addition of water on to the filter paper substrate.

Table VII records the total mass of the two individuals of each set, the weight gain (mg.) during the experiment, and the dry weight of leaf material consumed in the six days. In two instances, weight was lost during the experiment. Both times, this occurred in only one animal of the pair. It may have been due to a metabolic disorder, or possibly to partial desiccation. These two results have not been included in the calculation of the mean values per animal shown in Table VII.

From the mean values, an individual weighing 32.5 mg. would have a net live-weight gain of 1 mg. in six days, after consuming 8.6 mg. of dry leaf matter. This represents an ecological growth efficiency of about 6%.

Overwintered poplar leaves were analysed for calcium content. They contained 5.2% calcium by dry weight. In six days, the average slater above, ingested about 0.46 mg. calcium. In the same period of time, it gained 1 mg. live weight (equivalent to 0.33 mg. dry weight). Since an average of 20% of the dry weight of the slater body is calcium, an increase of 0.33 mg. dry weight represents the assimilation of 0.07 mg. calcium. Thus, the efficiency of calcium assimilation is 15%.

TABLE VII

The relationship of weight gain to leaf matter
consumed in P. scaber pairs, after a 6 day
experimental period.

Mass of two individuals (mg.)	Weight gain after 6 days (mg.)	Leaf matter consumed in 6 days (mg.)
78.4	3.4	15.7
81.6	4.0	22.3
83.9	-0.4	21.1
51.8	1.7	15.4
57.0	2.0	14.7
60.7	2.4	16.1
52.3	-0.6	15.9
47.7	0.5	15.4
32.5*	0.95*	8.6*

* mean per individual

8.3 Discussion

Several studies (Lafon, 1943; Auzou, 1953) have reported the amount of calcium, or mineral salts present in the isopod integument. The proportion of calcium in the dry weight of 100 P. scaber (mean dry weight 11.0 mg.) was 15% (Auzou, 1953).

In the present study, the proportion of calcium depends upon the size of the individual selected. For a 15 mg. animal aged about 1.5 years, the proportion was 26%, whereas for an older 20 mg. animal, only 16% of the body weight was calcium. Richards (1951) found that the lobster integument had a constant proportion of calcium from youth to old age, but that the percentages of the elements sulphur and phosphorus, doubled over the same period.

As an isopod becomes larger, the surface area to volume ratio will decrease, and the integument fraction of the body weight will be reduced. Thus, even if the percentage of calcium in the integument remained constant, the proportion of calcium in the body would be reduced as the animal grew older.

In a feeding study, Auzou (1953) kept 10 slaters with an initial mean weight of 46.3 mg. for 30 days in the laboratory. They were fed on rotten wood which was 4.3% calcium by dry weight. Over the 30 days, the mean weight animal, containing 2.12 mg. calcium, retained 0.785 mg. calcium from its food. The efficiency of calcium assimilation was 55 - 68%. This is very much higher than the value (15%) obtained in the present study, but the rate of assimilation may depend on the moult status of the individual, especially since about 50% of the total body calcium is lost at each moult (Auzou, 1953). Thus, a rapid extraction of calcium from the food immediately after the moult is necessary to restore the normal properties of the integument. The isopods used by Auzou had moulted shortly before his

experiments commenced. In the present study, the moult status of the animals was unknown but the results indicate that moulting had not occurred for some time.

The leaf consumption of a 35 m.u. P. scaber individual was found to be 2 mg. dry weight per day, by Wieser (1965). This is very close to the value found in this study. A slater will consume its own dry weight in leaf material in one week. Hence, the decomposer role of isopods in the community is likely to be very important.

Isopods also act as reservoirs of calcium in the habitat. In the "random" samples about 40 individuals were collected in each 0.1 m² sample of soil. If the mean head width of these animals is taken as 65 m.u., then each animal will have a dry weight of about 4 mg., and will contain 0.8 mg. of calcium. This represents 0.35 g. of calcium per 0.1 m² under the boards. A study on a very dense population (7.34 adults per m²) of millipedes in New York (Shaw, 1968) reported a calcium reservoir in the animals, of 0.66 - 0.82 g. per m² over the whole area. The results for P. scaber are not applicable for the whole area, since the boards, acting as shelter sites, probably acted to create aggregations rather than represent the dispersion over the habitat. Even so, it is apparent that isopods contribute significantly to the biotic mineral reservoir.

8.4 Conclusions

The proportion of calcium in the body of P. scaber individuals is reduced as the animal grows larger. Isopods make at least two significant contributions to community function - as decomposers, and as reservoirs of calcium.

9. SUMMARY

1. The dynamics of a New Zealand population of Porcellio scaber resident in waste grassland, were investigated. Population characteristics were determined from data gathered from two types of sampling. "Random" samples were collected from under cryptozoa boards laid out in 1 x 6 m. units, and "nonrandom" samples were taken in an adjacent area wherever the isopods were seen to be abundant.
2. Size distributions, based on head width, were used to assess age structure of each sample. One, two, and three year old individuals could be distinguished in the distributions.
3. Considerable variation in age structure was found between the sample types. "Random" samples contained a large proportion of slaters over a year old, whereas "nonrandom" samples comprised predominantly juvenile individuals. No concrete reasons for this distinction could be determined.
4. Overall, females were the predominant sex, although sex differences occurred between the sample types. The sex ratio changes with age of the slaters. First generation slaters had more females than males, whereas later generations favoured males. Some seasonal variation in the proportion of the sexes was found. Males were the predominant sex in "random" collections until the last two months, when females became predominant. This may be associated with the change in reproductive status that occurred at that time.
5. The breeding season lasts for about seven months, from spring through to autumn. Some correlation appears to exist between

timing of the season, and temperature and/or daylength.

6. Juvenile P. scaber become sexually mature, and can breed one year after their birth.
7. Brood size varied from 9 ova in a small female, to 114 larvae and ova in an exceptionally large slater. A progressive increase in the number of ova with increasing head width was demonstrated.
8. A natality estimate of 6000 young from a population of 1000 slaters was obtained when an 80% level of breeding among females was used. The mortality rate among young P. scaber was very high; an estimated 74% of the ova survived to birth. In a laboratory study that used the young of gravid females taken from the field, only 11% survived to 40 weeks of age.
9. The rate of growth of newborn slaters varied with age, with temperature, and with density of the young.
10. The following size relationships increased in a linear fashion - head width and body width; head width and body length; and body width and body length.
11. The dry weight of each individual was approximately $\frac{1}{3}$ of the fresh weight.
12. As size increased, the total amount of calcium found in the body also increased, yet the proportion (by percentage) of calcium decreased. Calcium constitutes between 16 - 26% of the dry weight of the body, depending on age of the slater.

10. REFERENCES

- Amanieu, M. (1965a). Variations au cours d'un annuel de la taille des individus d'une population Arcachonnaise de Porcellio scaber scaber Latreille, 1804 (Isopode terrestre). C.R. Acad. Sc. Paris, 260 : 5634-5637.
- Amanieu, M. (1965b). Cycle reproducteur annuel a Arcachon d'une population maritime de Porcellio scaber scaber Latreille, 1804 (Isopode terrestre). C.R. Acad. Sc. Paris, 260 : 5907-5910.
- Amouriq, L. (1967). Role des effets de groupe et de masse sur la croissance, la maturite sexuelle, la fecondite des jeunes de Porcellio scaber Latr. Bull. Soc. Zool. Fr., 92(1) : 177-185.
- Auzou, M.L. (1953). Recherches biologiques et physiologiques sur deux Isopods Onisciens : Porcellio scaber Latr. et Oniscus asellus L. Ann. Sc. nat. Zool. et Biol., 15 : 71-98.
- Bailey, N.T.J. (1959). Statistical Methods in Biology. English University Press.
- Brereton, J. le G. (1956). A study of factors controlling the population of some terrestrial Isopods. Unpublished Ph.D. Thesis, University of Oxford.
- Brereton, J. le G. (1957). The distribution of woodland isopods. Oikos, 8 : 85-106.
- Chilton, C. (1901). The terrestrial isopoda of New Zealand. Trans. Linn. Soc. Lond. ser 2, 2 : 99-152.
- Cole, L.C. (1946). A study of the cryptozoa of an Illinois woodland. Ecol. Monogr., 16 : 50-86.

- Collinge, W.E. (1915). Some observations on the life history and habits of Isopoda (Woodlice). Scot. Nat., 24 : 299-307.
- Den Boer, P.J. (1961). The ecological significance of activity patterns in the woodlouse Porcellio scaber Latr. (Isopoda). Arch. Neerl. Zool., 14 : 283-409.
- Edney, E.B. (1951). The evaporation of water from woodlice and the millipede, Glomeris. J. Exp. Biol., 28 : 91-155.
- Ellis, R.J. (1971). Notes on the biology of the Isopod Asellus tomalensis (Harford) in an intermittent pool. Trans. Amer. Micros. Soc., 90(1) : 51-61.
- Geiser, S.W. (1934). Further observations on the sex ratios of terrestrial isopods. Field and Lab., 3 : 7-10.
- Gere, G. (1962). Nahrungsverbrauch der Diplopoden und Isopoden in Freidlanduntersuchungen. Acta Zool. (Budapest), 8 : 385-415.
- Gunn, D.L. (1937). The humidity reactions of the woodlouse, Porcellio scaber. J. Exp. Biol., 14 : 178-186.
- Hatchett, S.P. (1947). Biology of the Isopoda of Michigan. Ecol. Monogr., 17 : 47-79.
- Heeley, W. (1941). Observations on the life histories of some terrestrial isopods. Proc. Zool. Soc. Lond., B 111 : 79-149.
- Herold, W. (1913). Beiträge zur Anatomie und Physiologie einiger Landisopoden. Zool. Jb. Anat., 35 : 457-526.
- Herold, W. (1924). Einige Daten über Wachstum, Gestaltveränderung und Lebensalters von O. asellus. Zool. Anz., 60 : 197-201.

- Howard, H.W. (1940). The genetics of Armadillidium vulgare Latr.
I. A general survey of the problems. Jour. Genetics, 40 :
83-108.
- Hurley, D.E. (1950). New Zealand terrestrial Isopods. Tuatara,
3(3) : 115-127.
- Hurley, D.E. (1961). A checklist and key to the Crustacea Isopoda
of New Zealand and the Subantarctic Islands. Trans. Roy. Soc.
N.Z. (Zool.), 1 : 259-292.
- Jackson, H.G. (1941). Checklist of the terrestrial and freshwater
Isopoda of Oceania. Smith. Misc. Coll., 99(8) : 1-35.
- Lafon, M. (1943). Recherches biochimiques et physiologiques sur la
squelette tegumentaire des arthropodes. Ann. Sci. Nat. Zool.
et Biol. Animale, 11 : 113-146.
- Miller, M.A. (1938). Comparative ecological studies on the
terrestrial Isopod Crustacea of the San Francisco Bay Region.
Univ. Calif. Publ. Zool., 43 : 113-142.
- Mocquard, J.P. (1968). Effects of grouping on the weight growth
of P. dilatatus (Brandt) in relation to the moult cycle, and the
sexual state. C.R. Acad. Sc. Paris, 266 : 2199-2201.
- Müller, I. (1943). Untersuchungen zur Gesetalichkeit des Wachstums.
X. Weiteres zur Frage der Abhängigkeit der Atmung von körperrösse.
Biol. Zbl., 63 : 446-453.
- Paris, O.H. (1963). The ecology of Armadillidium vulgare (Isopoda:
Oniscoidea) in Californian grassland: food, enemies, and
weather. Ecol. Monogr., 33 : 1-22.

- Paris, O.H. (1965). The vagility of P^{32} labelled isopods in grassland. Ecology, 46 : 635-648.
- Paris, O.H. and Pitelka, F.A. (1962). Population characteristics of the terrestrial isopod Armadillidium vulgare in California grassland. Ecology, 43(2) : 229-248.
- Paris, O.H. and Sikora, A. (1965). Radiotracer demonstration of isopod herbivory. Ecology, 46 : 635-648.
- Richards, A.G. (1951). The Integument of Arthropods. Minnesota Press, Minneapolis.
- Shaw, G.G. (1968). Population size, ecology and mineral reservoir of the millipede, Narceus annularis (RAF.). Ecology, 49(6) : 1163-1166.
- Sutton, S.L. (1968). The population dynamics of Trichoniscus pusillus and Philoscia muscorum (Crustacea: Oniscoidea) in limestone grassland. J. Anim. Ecol., 37 : 425-444.
- Thomson, G.M. (1922). The Naturalisation of Plants and Animals in New Zealand. Cambridge University Press.
- Vandel, A. (1925). Recherches sur la sexualite des Isopodes. Bill. biol. Fr. Belg., 59 : 317-371.
- Vandel, A. (1939). Sur la mode de repartition des sexes chez l'Isopode Terrestre, Armadillidium vulgare (Latr.). C.R. Acad. Sc. Paris, 208 : 1050-1052.
- Verhoeff, K.W. (1917). Uber die Larven, das Marsupium und die Bruten der Oniscoidea. Arch. f Nat., 83(12) : 1-54.

- Verhoeff, K.W. (1920). Zur Kenntnis der Larven, des Brutsackes
under der Bruten der Oniscoidea. Zool. Anz., Leipzig, 51 :
169-189.
- Wieser, W. (1965). Untersuchungen über die Ernährung und
Gesamtstoffwechsel von Porcellio scaber (Crustacea: Isopoda).
Pedobiologia, 5 : 304-331.
- Wieser, W. (1966). Copper and the role of Isopods in degradation
of organic matter. Science, 153 (3731) : 67-69.
- Wieser, W. and Schweizer, G. (1970). A re-examination of the
excretion of nitrogen by terrestrial isopods. J. Exp. Biol.,
52 : 267-274.