

Copyright is owned by the Author of the thesis. Permission is given for a copy to be downloaded by an individual for the purpose of research and private study only. The thesis may not be reproduced elsewhere without the permission of the Author.

CORTISOL METABOLISM

IN THE SHEEP

(Romney breed)

A thesis presented in partial fulfilment of the  
requirements for the degree of Master of Science

by

Alan Keith LANGFORD

Massey University

New Zealand

1968

## ACKNOWLEDGEMENTS

The author wishes to thank his supervisor, Dr. R. M. Greenway, for his generous help extended during the course of this study, with appreciation for the surgical preparations which allowed pursuit of some interesting facets of this investigation.

Thanks are due to Mrs. J. Strickland for collection of the rhythm samples; to the Physiology and Anatomy Department of Massey University for the use of their facilities and animals; and to Prof. R. A. Hodges for determining the mass spectra of several steroids isolated in this study.

Special appreciation is extended to Mrs. J. Taylor for typing this thesis.

To those who assisted in any other way during the course of this study, the author extends his gratitude.

---

ABSTRACT

The metabolism of cortisol in the normal Romney ewe was investigated by analysis of the radioactive metabolites excreted in the urine following intravenous (I.V.) administration of 4-c<sup>14</sup>cortisol. The metabolite glucuronides were hydrolysed with  $\beta$ -glucuronidase and extracted from the aqueous medium with ethyl acetate. The neutral fraction was divided into c-19 and c-21 metabolites by sequential elution from a florisil column. Extensive use was made of T.L.C. for the separation and analysis of each fraction before the quantitation of individual components.

A series of experiments was performed with surgically modified sheep involving collection of bile and urine both after I.V. injection of 4-c<sup>14</sup>cortisol, and after intraduodenal infusion of radioactive biliary metabolites obtained from I.V. administration of 4-c<sup>14</sup>cortisol. The metabolites collected at each stage were analysed both qualitatively and quantitatively.

The urine collected each hour for 18 consecutive days from a normal sheep, was subjected to colorimetric determination for  $\alpha$ -ketol and 17-ketogenic steroid content. The data obtained was analysed for diurnal variation in chromogen output, and the daily secretion rate of cortisol was estimated.

Fig 0.1a

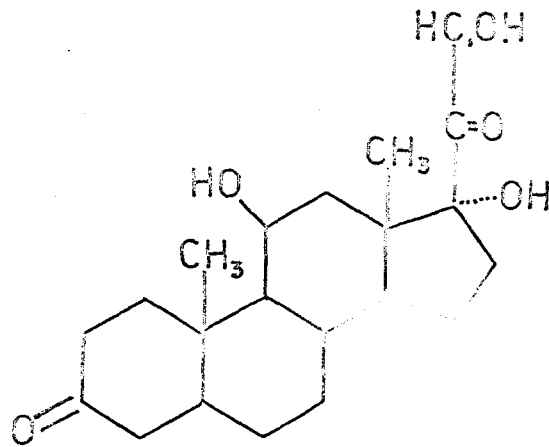

CORTISOL

Fig 0.1 b

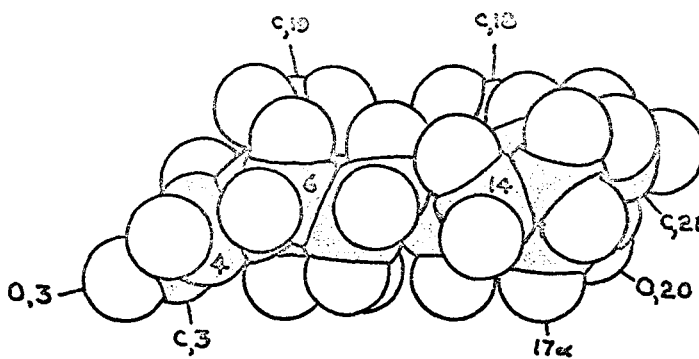

CORTISOL (side view)

## NOMENCLATURE

Nomenclature used throughout this script is based on that evolved from the Giba Conference in London (1950) and is generally in accordance with that approved by the International Union of Pure and Applied Chemistry (I.U.P.A.C.-see Biochemistry (Wash.) 8, 2227 (1969).

The steroid skeleton is numbered as shown in fig.0.2 . For compactness the terms Androstan- and Pregnan- are reduced to A- and P-, respectively. Double bonds in the parent structure are positioned by the suffix -ene-, eg. P-4-ene-. The configuration of the hydrogen at c-5 is indicated by a prefix 5a- or 5b-. The prefix allo- when used, refers to a 5a- configuration ( fig. 0.2).

Substituents are prefixed by numerical position and Greek letter (when pertinent), but numerating particles are omitted. Substituents attached to the nucleus on the same side as the angular methyl groups at c-10 and c-13, are designated b- and drawn with a heavy line; those below the plane of the ring are a- and drawn with a broken line ( fig. 0.1 ).

## TERMINOLOGY & ABBREVIATIONS

ACTH	adrenocorticotrophic hormone
Adrenocortical steroid, corticosteroid	- steroid from adrenal cortex, usually a c-21.
B.T.Z.	blue tetrazolium (chloride)
c-19	steroid with no side chain at position 17.
c-21	steroid with a two carbon side chain.
Conjugate	formed by esterification with a small molecule eg. glucuronic acid (glucuronide).
C.R.F.	corticotrophin releasing factor.
EtAc	ethyl acetate
EtOH	ethanol
Glycerol side chain	- =C,OH-CH,OH-CH <sub>2</sub> OH
a-ketol side chain	- -CO-CH <sub>2</sub> OH
17 ketogenic	- c-21 corticosteroid attacked by mild oxidising agents to give a 17-ketosteroid.

17 ketosteroid - steroid with a ketone on carbon-17.

Kg kieselgur

SG silica gel

Steroid nucleus - structure based on the cyclopentano-  
-phenanthrene skeleton with c-10 and c-13  
methyl groups

Tetrahydro derivative by complete hydrogenation of ring-A  
T.L.C. thin layer chromatography.

T.M.A.H. tetramethyl ammonium hydroxide.

---

<u>Trivial Name</u>	<u>Abbreviation</u>	<u>Mol. formula</u>
cortisol	F	P-4-ene-11b,17a,21-ol-3,20-one
urocortisol	THF	5b-P-3a,11b,17a,21-ol-20-one
allotetrahydrocortisol	allo"	5a-P-3a,11b,17a,21-ol-20-one
cortisone	E	P-4-ene-17a,21-ol-3,11,20-one
urocortisone	THE	5b-P-3a,17a,21-ol-3,20-one
cortol	-	5b-P-3a,11b,17a,20a,21-ol
b-cortol	-	5b-P-3a,11b,17a,20b,21-ol
cortolone	-	5b-P-3a,17a,20a,21-ol-11-one
b-cortolone	-	5b-P-3a,17a,20b,21-ol-11-one
11-OH-Androsterone	11OHA	5a-A-3a,11b-ol-17-one
11-keto-Androsterone	11KA	5a-A-3a-ol-11,17-one
11-OH-Etiocholanolone	11OHE	5b-A-3a,11b-ol-17-one
11-keto-Etiocholanolone	11KE	5b-A-3a-ol-11,17-one
corticosterone	B	P-4-ene-11b,21-ol-3,20-one
deoxycorticosterone	11DOC	P-4-ene-21-ol-3,20-one
dehydroepiandrosterone	DHEA	A-5-ene-3a-ol-17-one
testosterone	-	A-4-ene-17b-ol-3-one

---

Fig 0.2

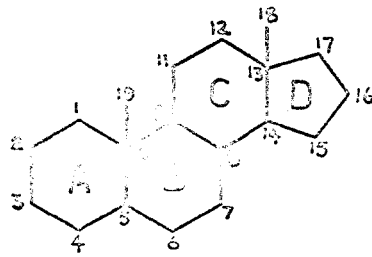

(a) Androstane

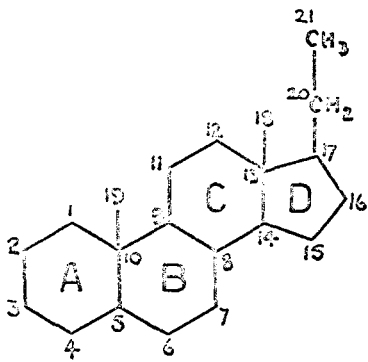

(b) Pregnane

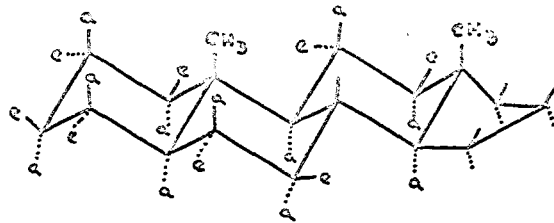

(c) 5 $\alpha$ -

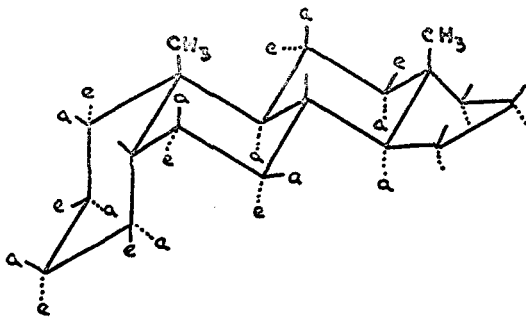

(d) 5 $\beta$ - Androstane

## TABLE OF CONTENTS

vi

	page
Abstract	iii
Nomenclature	iv
Terminology and Abbreviations	iv
 Chapter	
1	Review of Literature
1.1	Metabolic effects of cortisol 1
1.1.1	Glucocorticoid properties of cortisol 1
1.1.2	Mineralocorticoid properties of cortisol 7
1.2	The adrenal cortex 8
1.2.1	Chemistry and anatomy 8
1.2.2	Nature of adrenocortical secretion 10
1.2.3	Rate of adrenal hormone secretion 13
1.2.4	Biosynthesis of corticosteroids 15
1.2.5	Cyclic secretion from the adrenal 15
1.3	Chemistry of the corticosteroids 17
1.3.1	Derivation of the corticosteroid structure 17
1.3.2	Structural features of the adrenal steroids 19
1.3.3	Stereochemistry of biological activity 21
1.4	The metabolism of cortisol 22
1.4.1	Reduction in ring-A 23
1.4.2	Side chain cleavage 27
1.4.3	Reduction of the 20-ketone 28
1.4.4	Hydroxylation 29
1.4.5	The cortisol-cortisone equilibrium 30
1.4.6	Reduction of 17-ketones 32
1.5	Steroid conjugation 33
1.6	Steroid-protein association in blood 36
1.7	Ultimate distribution 40
 2	Materials and Experimental Methods
2.1	Materials 42
2.2	Preparation and care of experimental sheep 42
2.3	Collection and preservation of samples 43
2.4	Extraction of steroid conjugates 43
2.5	Hydrolysis of steroid conjugates 44
2.5.1	Assay of b-glucuronidase 44
2.5.2	Optimum pH of paua b-glucuronidase 45
2.5.3	Protein precipitation from paua stomach 45
2.5.4	Partial purification of paua b-glucuronidase 46
2.5.5	Partial purification of limpet b-glucuronidase 47
2.5.6	Enzymic hydrolysis of conjugates 47
2.5.7	Acid hydrolysis of conjugates 49

2.6	Extraction of neutral free steroid from aqueous solution	50
2.7	Steroid separation techniques	51
2.7.1	Column chromatography	51
2.7.2	Thin layer chromatography	53
2.7.3	Detection of corticosteroids on thin layer plates	57
2.8	Methods of corticosteroid analysis	59
2.8.1	Recording of I.R. and U.V. spectra	59
2.8.2	Chemical modification of the corticosteroids	60
2.8.3	Colorimetric methods	64
2.9	Radiochemical Procedures	66
2.9.1	Radioactive materials	66
2.9.2	Quantitative determination of radiochemicals	66
3	Experimental and Results	69
3.1	The -3,17-ol-11-one group	70
3.1.1	Characterisation of c-19-6, c-19-8	70
3.1.2	Characterisation of c-19-9	73
3.1.3	Characterisation of c-19-7	74
3.2	The -3,11,17-ol group	75
3.2.1	Characterisation of c-19-2, c-19-3	76
3.2.2	Characterisation of c-19-1, c-19-4	77
3.2.3	Characterisation of c-19-5	77
3.3	The 17-ketosteroid group	78
3.4	Quantitation of the c <sup>14</sup> -19-metabolites	79
3.5	Characterisation of the c-21-B series	81
3.6	Characterisation of the c-21-A series	83
3.7	Quantitation of c <sup>14</sup> -21-metabolites	85
3.8	Investigation into the pathways of cortisol metabolite excretion	85
3.8.1	Expt.-1 Urinary excretion of c <sup>14</sup> -F metabolites in whole sheep	86
3.8.2	Expt.-2 Excretion of c <sup>14</sup> -ketosteroid in bile and urine	87
3.8.3	Pathways of cortisol excretion	88
3.9	Investigation of diurnal variations in urinary metabolite excretion	90
3.9.1	Quantitation of B.T.A. chromogen	91
3.9.2	Quantitation of Zimmerman chromogen	92
4	Discussion	
4.1	Hydrolysis of steroid conjugates	93
4.2	Excretion of steroid conjugates	95

4.3 Extraction of free steroid	95
4.4 Chromatographic analysis of corticosteroids	96
4.5 Route of disposal of cortisol	97
4.6 Metabolism of cortisol in whole sheep	99
4.7 Metabolism of cortisol in surgically modified sheep	102
4.8 Methods of colorimetric estimation of corticosteroids	106
4.9 Colorimetric estimation of 17-OH-CS in the sheep <sup>in the sheep</sup>	108
4.10 Cortisol production rate in the sheep	111
4.11 Diurnal variations of corticosteroid metabolites in sheep urine	111
Summary	116
Literature cited	119

LIST OF TABLES

	page
1-1 Cortisol secretion rates . . . . .	14a
1-2 Plasma corticosteroid binding capacity . . . . .	37a
1-3 Distribution of total plasma cortisol . . . . .	37a
2-1 Extraction of conjugates from urine . . . . .	45a
2-2 Elution characteristics of florisil . . . . .	52a
3-1 List of c-19 metabolites (whole sheep) . . . . .	69a
3-2 Digitonin precipitation of c-19-6,8 . . . . .	72a
3-3 Borohydride reduction of c-19-6,8 . . . . .	72a
3-4 Borohydride reduction of c-19-8,9 . . . . .	73a
3-5 $AR_{Mr}$ values for 11=O reduction . . . . .	73a
3-6 Borohydride reduction of c-19-7 . . . . .	73a
3-7 F.L.C. of c-19-2,3 . . . . .	76a
3-8 F.L.C. of c-19-2 . . . . .	76a
3-9 $CrO_3$ oxidation of c-19-2,3 . . . . .	78a
3-10 Comparison of c-19-7,8 with c-19-2,3 . . . . .	77a
3-11 F.L.C. of c-19-1,4 . . . . .	77a
3-12 $R_M$ and $AR_M$ values for 17b-17a epimerisation . . . . .	78a
3-13 F.L.C. of 17-ketosteroids . . . . .	78a
3-14 $CrO_3$ oxidation of 17-ketosteroids . . . . .	78b
3-15 Borohydride reduction of 17-ketosteroids . . . . .	78b
3-16 F.L.C. of reduced 17-ketosteroid . . . . .	78b
3-17 F.L.C. of 2,4- $\Delta^4$ derivatives . . . . .	78b
3-18 Quantitation of c-21 metabolites . . . . .	79b
3-19 F.L.C. of acetylated cortols . . . . .	84a
3-20 Mild oxidation of c-21 fraction . . . . .	84a
3-21 $AR_M$ values for 11=O reduction . . . . .	84a
3-22 Urinary excretion of I.V.-cortisol . . . . .	87a
3-23 Excretion of ketosteroid . . . . .	87a
3-24 Excretion of F in modified sheep . . . . .	87a
3-25 Quantitative analysis of experiment-3 . . . . .	89a
4-1 Diurnal excretion of ketonic chromogen in the cow . . . . .	112

LIST OF FIGURES

	page
0.1 Structure of cortisol . . . . .	iiia
0.2 Nomenclature of steroids . . . . .	va
1.1 Biosynthesis of cortisol . . . . .	15a
2.1 Optimum pH of puaa b-glucuronidase activity	45a
2.2 Protein precipitation from puaa stomach .	45b
2.3 Methanolic fractionation of b-glucuronidase	46a
2.4 Hydrolysis of steroid conjugate - buffer .	48a
2.5 Hydrolysis of steroid conjugate - urine .	48b
2.6 Extraction of free steroid . . . . .	50a
2.7 Florisil column fractionation (2% MeOH). .	52b
2.8 " " " (2.5% MeOH) .	52c
2.9 " " " (5% MeOH). .	52d
2.10 Fractionation of 4-c <sup>14</sup> -F metabolites . .	52e
2.11 Bisulfate side chain cleavage . . . . .	63a
3.1 Scan of c-19 H.L.C. separation . . . . .	69b
3.1a Scan of 17-ketosteroid separation . . . .	69c
3.2 Autoradiograph of c-19 H.L.C. separation .	69d
3.3 Separation of c-19 fraction into components	79a
3.4 Scan of c-21 separation by H.L.C. . . . .	81a
3.4a Autoradiograph of c-21 H.L.C. separation .	81b
3.5 Quantitation of c-21 metabolites . . . .	79b
3.6 a,b,c,d, - scan of IVB, IVU, IFB, IFU H.L.C. chromatograms respectively .	89b-
3.7 Diurnal excretion of a-ketol . . . . .	91a
3.8 Diurnal excretion of 17-KGS . . . . .	92a
3.9 Urine volume variations . . . . .	92b
4.1 Comparison of a-ketol and 17-KGS excretion .	114a
4.2 Diurnal excretion of reducing corticoids in rams . . . . .	114b
Overall metabolism of cortisol in the sheep	118a

Chapter 1

REVIEW OF LITERATURE

1.1 Metabolic Effects of Cortisol

In most mammalian species cortisol is the principal steroid secreted by the adrenal gland (Bush,1953). It is also the adrenal steroid with the greatest glucocorticoid activity and so provides most of the effects the adrenal secretion has on carbohydrate and protein metabolism. Although the mechanism of action of the glucocorticoids remain unclear, a sequence of biochemical and metabolic events following administration of glucocorticoids has been well documented.

1.1.1 Glucocorticoid properties of Cortisol

Cortisol is an important regulator of protein, carbohydrate, lipid, and nucleic acid metabolism, as well as influencing inflammatory and lymphoid tissue, and indeed most tissues of the body.

1.1.1.1 Effect of Cortisol on Protein

1.1.1.1a Protein Catabolism

The ability of cortisol to restore the decrease in urinary nitrogen excretion produced by adrenalectomy in rats, was demonstrated by Long et al(1940). Associated with this effect on protein catabolism there is less utilisation and greater retention of glucose, as liver and muscle glycogen (Thorn,1940). Cortisol was found to increase the rate of accumulation of amino nitrogen in blood or plasma of hepatectomised animals, but not to the same extent in the whole animal (Bondy et al,1954).

The administration of cortisol to nephrectomised rats resulted in an increase of plasma urea of 0.5 - 1.0 mgm/ K Gm body weight per hour, after 3-6 hours

(Engel, 1950).

Further indications of cortisol induced protein catabolism are thinning of the skin, fall in antibody titer and involution of the thymus.

#### 1.1.1.1b Amino Acid Uptake by the Liver

Within two hours of administration of cortisol to a whole animal the uptake of amino acids by the liver is increased (due to increased permeability of the liver cell membrane to amino acids), with a concurrent increase in hepatic urea production (Riggs, 1964). The increase of amino nitrogen cannot be demonstrated in the isolated liver confirming the view that cortisol tends to increase protein catabolism in extrahepatic tissues and the amino acids are transported to the liver. The liver appears to metabolise the extra amino acids in the usual manner, contributing to urea and glucose production, but Long et al (1940) have observed the hepatic glucose response to cortisol precedes changes in nitrogen metabolism (Bondy et al, 1954). It is clear therefore, that cortisol induced increases in plasma amino acid concentrations is independent of the liver.

#### 1.1.1.1c Protein Synthesis

The liver has been shown to exhibit a positive nitrogen balance under the influence of cortisol, in contrast to most extrahepatic tissues which show a nett depletion of protein (Clark, 1953). An increase of total protein content of other tissues has been shown (Kochakain Robertson, 1951). These include the gastrointestinal tract, urogenital organs and plasma albumin (Silber and Porter, 1953), while a nett decrease has been demonstrated in the case of rat diaphragm (Wool and Weinshelbaum, 1959).

The observed increase in the activity of liver RNA-nucleotidyltransferase, 30 minutes after cortisol administration, is followed by an increase in the biosynthesis of messenger RNA after 2 - 3 hours and

an increase in protein synthesis by cytoplasmic ribosomes after 4 - 10 hours. Maximum RNA concentration occurs after 16 hours, and maximum protein concentration after 20 hours. (Feigelson and Feigelson, 1963)

#### 1.1.1.1d Nucleic acids

Immunological techniques have demonstrated cortisol stimulation of specific enzyme protein synthesis (Greengard and Feigelson, 1962; Kenny, 1962) which may be blocked by actinomycin and puromycin, suggesting nucleic acid participation (Jervell, 1963). Cortisol has been found to inhibit nucleic acid synthesis in most tissues including lymphatic tissue (Jedeikin and White, 1958) but liver RNA is increased without any change in DNA content. (Silber and Porter, 1953)

It is evident therefore, that cortisol stimulation of the synthesis of specific hepatic proteins is mediated through increased messenger RNA production in the liver.

#### 1.1.1.2 Effect of Cortisol on Lipids

Cortisol seems to be necessary for full mobilisation of fatty acids from adipose tissue (Havel and Goldfein, 1959) indeed, the fatty acid mobilising effects of catecholamines and other lipolytic hormones require the presence of cortisol for their maximum lipid mobilising action (Goodman and Knobil, 1961). The mineralocorticoid, 11 DCC, can replace cortisol in this respect but its action is considerably weaker. The effect of glucocorticoids upon nonesterified fatty acid release from adipose tissue in vivo, was confirmed by Scow co-workers in rats, and Gillman et al (1958) in baboons, and established the adrenocortical effects upon lipid mobilisation and ketogenesis.

#### 1.1.1.3 Effect of Cortisol on Carbohydrates

##### 1.1.1.3a Glucose production

The administration of cortisol to rats causes an

elevation of blood glucose level (B.G.L.) (Ashmore et al, 1961) evident after 2 to 4 hours (Ashmore et al, 1958) and may reach a level of 40 - 50 mgm/100 ml. of blood, and can be sustained for up to 48 hours.

Conversely adrenalectomy will decrease the B.G.L., as demonstrated by Wagle and Ashmore (1961), who noted the increase in B.G.L. of diabetic rats, was returned to normal with adrenalectomy.

The increase in B.G.L. due to cortisol may be produced by a decrease in peripheral glucose utilisation, or an increase in hepatic glucose production (Glenn et al, 1961) (A seven-fold increase in rats has been observed (Bass et al, 1963)), or both. The increase in glucose production by the liver is derived in part from lactate and alanine (Lewis et al, 1940) and was first observed as a function of cortisol by Koepf et al (1941) using liver slices from adrenalectomised rats and adrenalectomised rats treated with a cortical extract. Attempts to demonstrate the same effect in liver slices by in vitro treatment with cortical extract have failed, probably due to the very rapid deactivation of cortisol by hepatic enzymes (Glenn et al, 1957). This deactivation has been overcome by using synthetic gluco-corticoids, such as triamcinolone and dexamethasone, which are less prone to deactivation by the liver. (Eisenstein et al, 1964). These synthetics will accelerate the conversion of a number of precursors (e.g. alanine and pyruvate) into glucose or glycogen (Uete and Ashmore, 1963) as well as increase fixation of  $C^{14}O_2$  both in vivo and in vitro (Ashmore et al, 1961).

Kidney tissue is also capable of gluconeogenesis and less glucose was found from pyruvate in kidney slices from adrenalectomised animals (Teng, 1954). Chronic treatment of rats with cortisone resulted in tissue slices from kidney having greater ability to incorporate pyruvate carbon into glucose (Landau, 1960).

#### 1.1.1.3b Glycogen Formation

Following administration of cortisol to adrenalectomised rats there is an increase in liver glycogen content after 3 to 24 hours (lagging behind the elevation of B.G.L.) which may reach 150 - 200 mgm per 100 Gm body weight and is maintained at this level for the next 24 hours (Engel, 1950). There is also a slight increase in muscle glycogen levels over 8 to 24 hours, but no apparent change in the kidney glycogen content was observed (Froesch *et al*, 1958). The enlargement of liver glycogen and total body carbohydrate are known to parallel the excretion of N.P.N. which more than accounts for the carbohydrate formed (about 60 - 70% of amino acids released are converted to carbohydrate) (Long *et al*, 1960). It was found that isolated rat liver tissue of adrenal in ectomised rats, formed less glycogen from its precursors than in intact rats (Lipsett and Moore, 1951).

Although glycogen deposition is evident 3 - 4 hours after administration of cortisol, most of the cortisol is excreted before its effects are evident. Pyridoxine deficient rats (Eisenstein, 1960) and rats given puromycin (Greengard *et al*, 1963) or actinomycin (Ray *et al*, 1964), exhibit up to 84% reduction in glycogen deposition, suggesting indirect action.

#### 1.1.1.3c Glucose Utilisation

Uptake of glucose by skin and lymphatic tissue (Jedeikin and White, 1958) is decreased with high plasma cortisol levels. A reduction in the amount of glucose utilised by adipose tissue is evident within 30 minutes of both in vivo and in vitro addition of cortisol, corticosterone or dexamethasone. (Munck, 1962).

Glucose utilisation by the liver is little, if at all, affected by cortisol concentrations. The phosphorylation of glucose may be under the control of glucocorticoids. Glucose phosphorylation is reduced in the diabetic rat liver but adrenalectomy has no effect, nor does chronic treatment with cortisone

(Ashmore, 1958).

Liver cell membranes are freely permeable to glucose, and glucose utilisation in the liver is a reflection of hepatic glucokinase activity. This enzyme is influenced by insulin but cortisol has no effect on its activity (Sharma, 1963).

#### 1.1.1.3d Role of the Liver

The fact that a deficiency or excess of glucocorticoid hormones influences the pattern of hepatic carbohydrate metabolism is indisputable. The insulin sensitivity of adrenalectomised animals was not present after hepatoectomy (Levine *et al.*, 1949) and the maximum capacity of peripheral tissue for the utilisation of glucose under the action of insulin also required the presence of the intact liver.

#### 1.1.1.3e Insulin-Cortisol Antagonism

The synthesis of fatty acids in diabetic liver is restored by adrenalectomy (Brady *et al.*, 1951), and conversely treatment of adrenalectomised diabetics with cortisol inhibits fatty acid synthesis (Ashmore *et al.*, 1956). This inhibition is evident in 2 to 6 hours and is concurrent with an increased conversion of pyruvate to glucose.

Incorporation of glucose carbon into fatty acids in adipose tissue of diabetic animals is not restored by adrenalectomy (Fair, 1964) but appears to be regulated by glucose utilisation. The reduction in glucose utilisation in adipose tissue brought about by cortisol is abolished in the presence of insulin.

#### 1.1.1.4 Effects of Cortisol on Enzymes

Changes in enzymic activity occurs slowly, varying from hours to days, under the influence of glucogenic hormone. Cortisol induced changes in enzyme activity are blocked by puromycin and actinomycin, supporting the hypothesis of a correlation between cortisol

action and the synthesis of RNA and protein.

#### 1.1.1.4a Glycolytic enzymes

Of the glycolytic enzymes studied, glycogen synthetase, hepatic phosphatases, phosphoenolpyruvate carboxykinase, phosphohexose-isomerase and aldolase show increases of the order of 200% over that in control systems, only after 3 to 6 days. The increase in hepatic glucose production is independent of an increase of any of these and their production may be due to secondary effects.

Phosphoglyceraldehyde dehydrogenase reaches a response of 200% over controls in 4 to 8 hours while pyruvate carboxylase increases to the same extent in 6 hours (Henning et al, 1963) by the influence of cortisol. However pyruvate carboxylase is also stimulated by acetyl-CoA and this apparent hormonal response may be of a secondary nature (Utter et al, 1963).

#### 1.1.1.4b Amino acid metabolising enzymes

Tryptophan pyrrolase and tyrosine transaminase were found to increase 900% and 750% over controls within 12 hours, while alanine transaminase and serine dehydrase required 48 hours to reach 300% and 500% increases over controls. In the case of tryptophan pyrrolase, increases in activity of this enzyme have been found to parallel the increase in synthesis of enzyme protein (Kenny, 1962).

#### 1.1.2 Mineralocorticoid properties of Cortisol

Cortisol contribution to mineral metabolism is weak in relation to that of 11-DOC or aldosterone (8% of 11-DOC and 0.1% of aldosterone activity in rats) (Tait et al, 1952) and are probably of a secondary nature. In prolonged usage, cortisol causes sodium and water retention and renal loss of potassium in humans. In dogs the renal response to 11-DOC and cortisol is essentially the same (Roberts and Randall, 1955).

In large doses cortisol is a potent natriuretic agent, enhancing sodium excretion several-fold, and can antagonise the opposite action of 11-DOC and aldosterone as seen in the rat and man (Laidlaw et al, 1955). In general, cortisol tends to enhance potassium excretion and is the most potent of the natural corticoids in stimulating water diuresis (Chart et al, 1956).

Plasma volume may be restored by cortisol after depletion due to adrenal insufficiency. This appears to result from decreased distal tubular epithelial permeability to water (Bleeman et al, 1965). Decreased sodium concentration in the papillary interstitium, also associated with adrenal insufficiency, is not corrected by doses of aldosterone (Sigler et al, 1965). An increase in glomerular filtration rate, which is independent of changes in sodium balance (mineralocorticoid effect), following administration of cortisol, has been observed (Garrod et al, 1955).

## 1.2 The Adrenal Cortex

### 1.2.1 Chemistry and Anatomy of the Adrenal

The adrenal is positioned in close proximity to the kidney. It consists of two regions - the inner medulla, richly supplied with sympathetic nerve fibres; and the outer cortex involved in corticosteroid biosynthesis.

The mammalian adrenal gland is claimed to have the highest blood flow of any organ in the body. The blood flow through the adrenal is increased upon stimulation with ACTH (in vivo) and also when subjected to a stressful environment (Richards and Pruitt, 1957). This increase in blood flow may be associated with stimulation of the adrenal or may be of a secondary nature such as an adrenaline response. Increases in blood flow itself have been shown to effect the release of cortisol (Urquhart, 1965). Only traces of steroid hormones and their precursors are found in the adrenal. Human adrenals normally contain 5.5 mgm total reducing

steroid/100 Gm adrenal tissue, and in rat adrenals the level is somewhat higher - 70 mgm/100 Gm tissue. The relative percentage of four hormones in the gland are cortisol 81%, corticosterone 13%, aldosterone 4%, cortisone 2%.

The gland has a high lipid (15% wet weight) content consisting mainly of cholesterol esters; (25 - 50% of total) quantities of ascorbic acid; and enzymes required for synthesis of the steroid hormones. Cholesterol concentration varies considerably, depending on diet, age and stress of the animal at the time of sampling. Ascorbic acid appears to be localised in all mammalian steroid secreting cells. The loss of ascorbic acid from the adrenal is in sympathy with the degree of stimulation of the gland. A multiplicity of enzymes are found in the adrenal, which have been divided into three classes:

- (1) Those directly involved in the biosynthesis of steroid hormones
- (2) Those generally found in active cells
- (3) Those found variably in adrenal and other sorts of cells.

The weight and composition of the adrenal cortex is dependent on the level of ACTH in the blood flowing through the adrenal (the medulla is little affected), and of the species so far studied only the S.American toad shows no gross adrenal atrophy upon hypophysectomy. However the resulting atrophy may also be due, in part, to a lack of growth hormone and thyroid hormone. The normal function of the adrenal may also be regulated by nutritional and environmental factors either directly or through control of ACTH release. The immediate (minutes) weight gain following treatment with ACTH is due to increase in water in the gland (Brodish and Long, 1960). Subsequently (hours) the increase in weight is indicative of a positive nitrogen balance. In general the growth maintenance and responsiveness of adrenocortical tissue is dependent on the continued

secretion of ACTH.

ACTH has been shown to produce a net increase in transfer enzymes (Scriba and Reddy, 1965) and RNA (Branson and Chargaff, 1964), although Actinomycin D cannot prevent the steroidogenic response of the adrenal tissue to ACTH, which involves an increased supply of NADPH<sub>2</sub> (Ferguson, 1962). Harding and Nelson (1964) however concluded from their experiments that NADPH<sub>2</sub> content of the adrenal is not involved in the regulation of steroidogenesis, whereas other investigators have.

That the site of action of ACTH is at a biosynthetic point before cholesterol was shown by Sarard and Casey (1964) although other investigators have shown that cholesterol is an obligatory intermediate in the dog and that ACTH acts at a point between cholesterol and pregnenolone (Krum et al, 1964).

#### 1.2.2 Investigation of the Nature of the Adrenocortical Secretion

Until recently, a study of adrenocortical secretion has been indirectly due to a lack of satisfactory methods for detecting the actual products of secretion of the adrenal. However, that the adrenal secreted two different types of hormones under separate control, was hypothesised, and has since been confirmed. Forms of assay are listed:

(1) Survival of the animal after adrenalectomy was a general, non specific test but was apparently more effective as a mineralocorticoid assay.

(2) Assay for glucocorticoids involved measuring increments in protein catabolism, glycogen deposition in the liver, etc. following adrenal secretion.

(3) Assay for mineralocorticoids was dependent on measurement of the increase in the Na /K ratio in the blood.

More specific information can be gained from the use of methods for detection of individual steroids in the adrenal effluent. The advent of chromatography

allowed the analysis of individual corticosteroids from the adrenal venous blood of a single animal (Bush, 1953).

The direct analysis of the adrenal cortex secretion, in both quantitative and qualitative aspects, may be conveniently divided into three sections:

- (1) In vivo - analysis of adrenal-venous or peripheral blood
- (2) In vitro - analysis of adrenal perfusates
- (3) In vitro - analysis of incubation media

#### 1.2.2.1 In vivo analysis of adrenal-venous or peripheral blood

Techniques for withdrawing samples of blood from the adrenal vein by permanently implanted catheter appear to be the most satisfactory. Using other methods the operation and even the anesthetic itself may serve to produce a rise in secretion from the adrenal with time (Nelson et al, 1956). Reduction in blood volume is also capable of increasing glucocorticoid output as well as aldosterone (Barrell et al, 1956). The most refined and least stressful methods yet devised give values for cortisol secretion of less than half that obtained by cannulation under anesthesia (Nelson et al, 1956). Basal levels of secretion cannot be obtained from peripheral blood analysis as the concentration here is a function of the metabolism and excretion rate as well as their secretion rate. The measurement of excretion levels after administration of radioactive tracer has many advantages and is now the preferred method (Van der Straeten et al, 1963). By 1955 approximately 30 steroids had been isolated from the adrenal cortex. Some are biosynthetic intermediates but many appear in the adrenal secretion. However by this time it had become increasingly evident that two of these, corticosterone and cortisol, could account for 60 - 100% of the total corticosteroid secretion in all species of animals studied, and under widely

varying conditions.

The ratio of these two major glucocorticoids normally found in mammals is characteristic of the species (Bush, 1955). The rat and rabbit secrete corticosterone as the predominant glucocorticoid, while dog, sheep, and humans secrete cortisol as the principal glucocorticoid. The ox has a F/B ratio close to unity (see table 1.1). Compound B and F are pharmacologically similar in most respects although F is far more active in bio-assays. No metabolic or haematological response to stress or ACTH has been shown attributable to these differences in type of secretion (Sayers, 1950).

The ratio may even vary to some extent in the same animal according to age, or degree and duration of stimulus by ACTH (Eik-Nes and Hall, 1965). In rabbits the F/B ratio changed from 0.05 in control animals to 4 after chronic treatment with ACTH over 3 - 4 weeks, with the corticosterone secretion dropping to about half that of the control animals. In humans the F/B ratio was higher after ACTH administration for 3 days prior to cannulation (Grant et al, 1957).

Other steroids may be present in the adrenal venous blood such as progesterone, 17-OH-progesterone, 11b-OH and 11-keto-progesterone, pregnenolone, and 17-OH-pregnenolone. These have been shown to have a venous/arterial ratio greater than unity, but may be present by incidental diffusion from cells active in the biosynthesis of corticosteroids. Other, often unidentified, compounds of unknown metabolic significance are also present. Cortisone is present as are other metabolites found in peripheral blood, but the venous/arterial ratio has not been shown to be significantly greater than unity for these compounds. The sheep has been found to secrete considerable quantities of A-4-ene-11b-ol-3,17-one (17-KS of cortisol). In the adrenal venous blood of an anesthetised sheep the predominant secretory product was F, being 10 to 15 times greater than corticosterone or A-4-ene-11b-ol-3,17-one.

All three of these a,b-unsaturated- $\beta$ -ketosteroids are secreted at a higher rate after stimulation by ACTH.

#### 1.2.2.2 In vitro perfusion of the adrenal

The adrenals of cats, dogs and cattle have been used for this method, usually with the gland isolated, but left in situ (Vogt, 1951). Hilton et al (1958) found as little as 1 milliU. of ACTH/litre of perfusate induced a sharp rise above the basal secretory rate of cortisol (some glucocorticoid is secreted by both isolated canine and bovine glands without added ACTH). This is of the same order of sensitivity as that found in vivo.

#### 1.2.2.3 In vitro incubation of adrenal gland preparations

The slices of adrenal gland are incubated in a suitable oxygenated medium for the required length of time, and then the medium is analysed for released steroid. Inclusion of ACTH in the medium was found to enhance formation of  $\alpha$ -ketolic corticosteroids. The activation sensitivity is rather less than that obtained by in vivo or in vitro analysis of venous blood or perfusate. A concentration of 50 - 100 milliU. of ACTH/6 ml. of medium was required for observable effect. The technique may be applied to adrenals from any source and the products found compare with those obtained by the other methods.

#### 1.2.3 Rate of Adrenocortical Hormone Secretion

Variation in the rate of adrenal hormone secretion has been determined by analysis of urinary metabolite changes in peripheral blood levels of corticosteroids, renal and adrenal venous/arterial differences, as well as in vitro procedures. Difficulties arise from the release in vivo of adrenocorticotrophic hormone (ACTH), as a result of the various manipulations during the measurement. Dorfman (1954) has estimated that basal corticosteroid production in the human was approximately

20 mgm per day (in both sexes). This value was reduced somewhat with age; the cortisol secretion of 60 - 70 year old men being about 75% that of 20 - 30 year old men (Romanoff et al, 1961). In general, most animals secrete between 1 and 10 mgm of corticosteroids per Kg body weight, per day (Bush and Ferguson, 1953).

In humans a reduction in the secretion of corticosteroids from the adrenal has been observed as a result of hypothyroidism (65% of normal), hypopituitarism (2%), Addison's disease (2%), and corticoid inhibition (20%). Conditions producing an increase in cortisol production rate are obesity (150% of normal), Cushing's Syndrome (250%), hyperthyroidism (150%) and ACTH (maximum response - 900%).

Control of the secretion of the adrenal cortex is principally by the action of ACTH, although the responsiveness of the adrenal tissue to stimulation by ACTH is also a variable factor (vide infra). Release of ACTH from the hypothalamus and initiation of ACTH synthesis, is effected by corticotrophin releasing factor (CRF), present mainly in the median eminence adjacent to the infundibular process of the hypothalamus. This action of CRF on the ACTH producing tissue is not influenced by the circulating levels of corticosteroids.

Two forms of neural stimuli may cause ACTH release above that of the basal level.

(1) Class 1 - stimulation insensitive to corticosteroid hormone feedback

(2) Class 2 - stimulation sensitive to corticosteroid hormone feedback

Class 1 impulses are conveyed to the site of CRF release, in the median eminence of the tuber cinerium, and in the infundibular process, through corticosteroid insensitive neurons. The corticosteroid sensitive and insensitive neurons lie in close proximity to each other and impulses may arise from corticosteroid sensitive neurons, which themselves do not contain CRF. Neural inhibition of corticosteroid insensitive

TABLE 1-1

Cortisol secretion rate and F/B ratio in some mammals

Terrestrial Species	F/B ratio <sup>†</sup>	Basal cortisol * secretion rate ug/ hr/ Kg
Dog	5-6	40 (12 - 75)
Ox	1	
Cat	1	50
Hamster	1.5	
Rabbit	< 0.1	
Rat	< 0.05	
Monkey	20	0.1
Sheep	10-15	15 (5 - 50)
Man	7	0.2

\* from Lazar and Jordan, 1985

† from Auch, 1955

CRF releasing neurons, is supplied by elements from the hippocampus. Cells that do contain CRF cannot receive inhibitory signals from these elements. That stimulation of the post hypothalamus may activate or inhibit ACTH release is probably the result of extensive inter-connections between the fore-brain and mid-brain.

Vasopression can also cause the release of ACTH (via CRF) and has been shown also to have a direct action on the adrenal cortex itself (Andersen and Egdahl, 1954). ACTH is known to inhibit its own release by negative feedback action on the brain or pituitary (Mitay et al, 1959).

#### 1.2.4 Biosynthesis of Corticosteroids

The in vivo biosynthesis of both labelled cholesterol and corticosteroid hormones from labelled acetate is well established. However Werbin and Chaikoff (1961) found that cholesterol for the immediate synthesis of cortisol, in the ACTH treated guinea pig was drawn from a small cholesterol pool with a rapid turnover. Other precursors can be used, these include desmosterol, the immediate precursor of cholesterol, which in rat adrenals is converted to cortisol at about the same rate as cholesterol.

#### 1.2.5 Cyclic Secretion of Corticosteroids from the Adrenal

Spontaneous circadian (about a day), or more correctly diurnal (12 hours) variations in adrenocortical activity was demonstrated indirectly in man by Elmadjian and Pincus (1946), through changes in the level of circulatory lymphocytes. The diurnal variation was shown more directly by 17OHCS concentration changes in blood (Tyler et al, 1954) and urine (Laidlaw et al, 1954). Such changes reflect a change in secretion of the adrenal cortex, rather than changes in metabolism.

The diurnal variation appears to be the basic excretory rhythm on which variations due to other

Fig 1.1

The Adrenal Biosynthesis of Cortisol

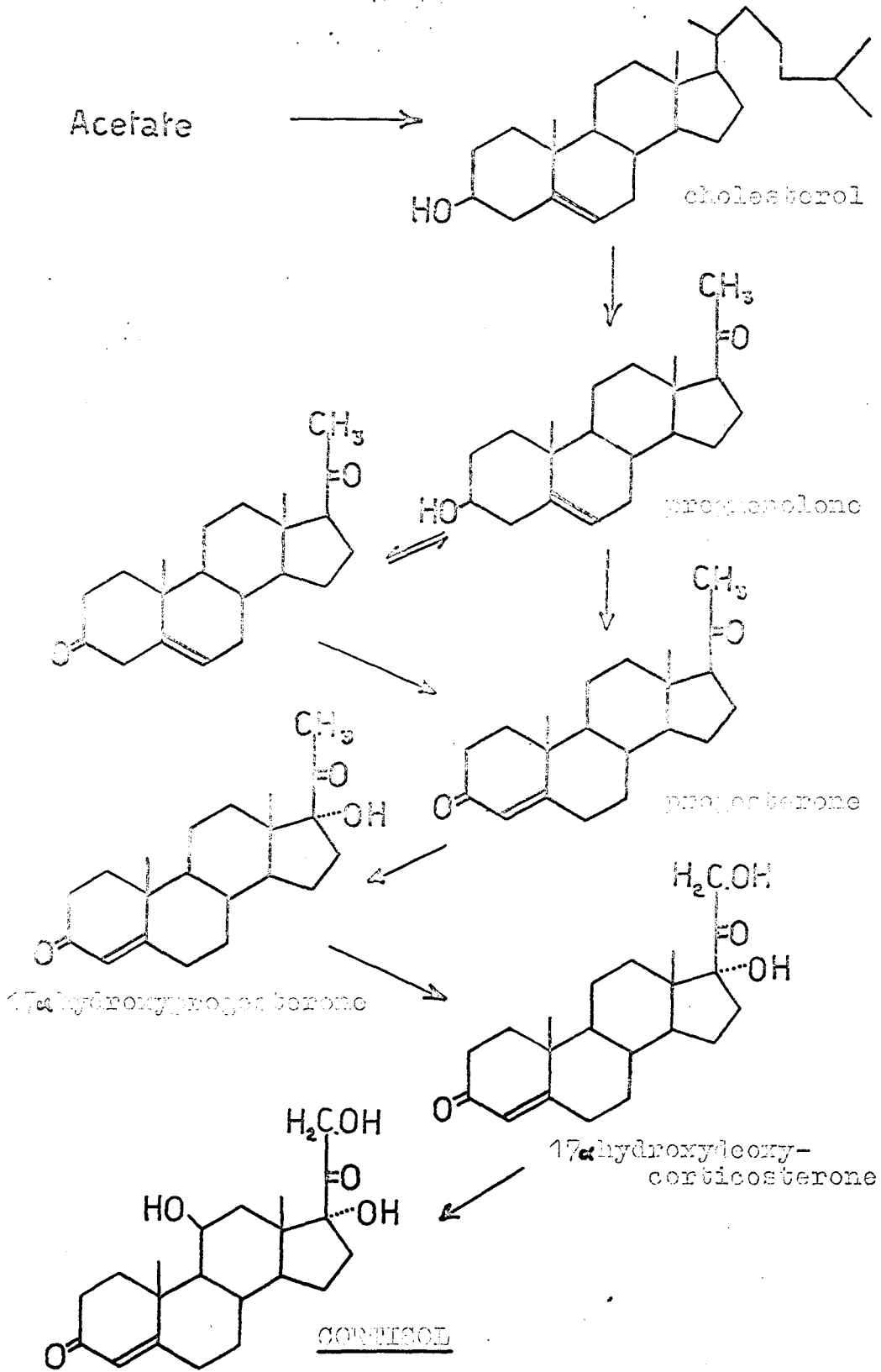

factors are imposed (Thorn, 1955). The presence of a rhythm in the 17OHCS secretion in animals is probably phylogenic with the monkey having a similar rhythm, but it is not so apparent in the dog (Berson and Yalow, 1952). The mechanism is not affected by muscle activity, food intake or urine volume output; but the cycle is not so well defined in blind subjects. Light synchronisation appears to be important but is not the only controlling factor.

The characteristic changes in 17OHCS metabolite secretion in the urine result in the lowest levels during the night and the highest during the morning; and in this respect resemble the well documented 17KS plasma and urinary rhythms (Forsham et al, 1955). Tyler et al (1954) found a 6 a.m. value for blood plasma 17OHCS level of 19 ug/100 ml., compared to 6 ug/100 ml. at noon; while Doe et al (1954) found a maximum at 9a.m., with the relative urine concentration following plasma concentration very closely but with greater amplitude. Sandberg et al (1953) have found a 2 hour delay in the urinary corticosteroid metabolite response to variation in plasma concentrations of the same. In contrast to this, Migeon et al (1956) found the urinary excretion of 17OHCS was almost the inverse of plasma level in four night workers studied.

Ungar and Halberg (1962) found that maximum response of the adrenal to exogenous ACTH occurs in the mouse when the plasma concentration of corticosterone is lowest. Nichols et al (1965) found dexamethasone given at the maximum point of cortisol output would suppress this secretion for a short period, whereas the same synthetic hormone given at a minimum would suppress cortisol secretion for the whole following 24 hours.

This suggests that the basis of diurnal variations in corticosteroid secretion is one of varying sensitivity of the adrenal to ACTH rather than fluctuations in ACTH secretion per se.

In addition to the large diurnal variation, the adrenal secretion also shows a biphasic response (Henkin and Knigge, 1963) which seems to be characteristic of continuous stresses. The biphasic response found in the sheep is further discussed in chapter 4.

### 1.3 Chemistry of the Corticosteroids

#### 1.3.1 Derivation of the corticosteroid structure

The abolition of the 'old' cholic acid structure of Wieland and Windaus, and subsequent confirmation of the structure proposed by Rosenheim and King in 1932, opened the way for chemical characterisation of the many compounds related to cholesterol. The term 'steroid' was proposed by Callow and Young (1936) to cover compounds uniquely characterised by conversion to Diels hydrocarbon by selenium or palladium - namely; sterols, bile acids, cardiac aglycones, toad poisons, saponins, some alkaloids and the sex hormones. The first steroid hormone to be isolated was estrone, in 1929.

Attempts to isolate the "adrenal hormone" and elucidate its structure came in the period from 1932 to 1935 led by the schools of Kendall (Mayo Clinic, U.S.A.), Reichstein (Zurich and Basel, Switzerland), Pfiffner and Wintersteiner (Squibb, U.S.A.), and Cartland and Kuizenga (Upjohn U.S.A.). During the period 1936 to 1942, about 30 different steroids were isolated, including 6 biologically active ones. Reichstein isolated corticosterone (Reichstein's-H) in 1936 in almost pure form, to be closely followed by Kendall. In 1937 Reichstein showed his compound-H had cortical activity (De Fre'mery et al, 1937). The school of Kendall isolated the adrenal hormone cortisone and demonstrated the presence of an  $\alpha, \beta$ -unsaturated ketone (spectroscopically) and the loss of  $C_2H_4O_2$  upon oxidation. Although Reichstein found cortisone to be physiologically inactive (probably due to insufficient dosage), Kendall reported physiological activity for both E and 11 dehydrocorticosterone (Kendall et al, 1937).

Initially, inactive (by biological assay) crystalline substances were isolated from adrenocortical extracts. They were shown to have the general formulae  $C_{21}H_nO_5$  ( $n=28$  to  $36$ ) with oxygen functions on the pregnane nucleus at positions 3, 17, 20 and 21. At a later stage all groups had obtained non-crystalline fractions at least ten times more potent than the pure compounds thus far isolated, also containing a predominance of  $C_{21}-O_5$  compounds.

Of the oxygenated  $C_{21}$  series, only the  $C_{21}O_5$  and  $C_{21}O_4$  compounds had been investigated by 1937. The brilliant chemical analysis of these compounds by Reichstein was to allow structure determination of many of the steroids isolated. His methods involved oxidation with chromium trioxide to a 17-ketone- $C_{19}-O_3$  (saturated) $H_{26}$  or (unsaturated) $H_{24}$  compounds which were compared with authentic compounds. Less drastic oxidation using lead tetraacetate and periodic acid was also used.

Although oxygen functions had been positioned at carbons 3, 17, 20 and 21, the position of the fifth oxygen was not easily resolved due to its seemingly inert nature. Chemical determination of the position on the nucleus of this oxygen is attributed to Kendall, who characterised the 2<sup>o</sup>-11b-hydroxyl and 2<sup>o</sup>-11-carbonyl groups. However the inert nature of the 11-oxygen group, and with the observed physiological activity of 11 deoxycorticosterone, it was considered that this was not a requirement for biological activity. Furthermore, Kendall found that reduction of the unsaturation between carbons 4 and 5 destroyed the biological activity of the molecule (Mason et al, 1937; followed by others - Wintersteiner and Pfiffner, 1936; Kuizenga and Cartland, 1939). Cortisone was isolated and described in 1936 by Mason et al (1936 & 1936a), Reichstein, Pfiffner and Whitensteiner and also by Kuizenga and Cartland in 1939. The absolute structure was determined by Reichstein (1936) and the now

accepted formula was also adopted by Kendall (Mason *et al*, 1938). By 1949 Kendall's group had noted the effect of cortisone on acute rheumatic fever and chronic rheumatoid arthritis following the availability of cortisone by chemical synthesis, due to the work of Sarett (1946).

Both Reichstein and Kendall reported the correct formula of cortisol, having a C-11-oxygen and Reichstein noted some trace of biological activity. (It is important to note that biological assays for adrenocortical activity were those of survival after adrenalectomy, or later, electrolyte level analysis). The formula of cortisol (Reichstein's compound-M and Kendall's-F) was confirmed later by Mason *et al* (1938 & 1938a).

As a result of the Chromatographic techniques of Bush (Bush, 1953) and Zaffaroni (Zaffaroni and Burton, 1953) the nature of the principal steroids of the adrenal gland has become clear.

### 1.3.2 Structural features of the Adrenocortical Steroids

All cortisol metabolites have oxygen functions in position 3, 11, and 17 in the Androstane series and on carbons 3, 11, 17, 20 and 21 in the Pregnane series. Additional hydroxyl groups may also be present.

#### 1.3.2.1 Physical and Chemical Properties of Steroid Ketones

The 17-carbonyl group may be produced from 17 $\alpha$ ,20-ol or 17 $\alpha$ -ol-20-one steroids by a 17 $\alpha$ ,20-C<sub>21</sub>-Desmolase enzyme (Lynn and Brown, 1958) or nonenzymically by mild oxidising agents. The 17-ketone group is recognised by formation of a purple colour with the Zimmermann's reagent (Zimmerman, 1935), while other carbonyl groups (-3 and -20) give colours unstable in alkali (Marlow, 1950). The 17-ketone which absorbs in the IR region 1742-1749 cm<sup>-1</sup>, can be distinguished from ketones attached to 6 member carbon rings (1705-1720 cm<sup>-1</sup>)

and c-20-ones ( $1705-1710\text{ cm}^{-1}$ ). The 4-ene-3-one group is easily recognisable by its unique property among the adrenal steroids of absorption at  $240\text{ }\mu\text{m}$ ., in the U.V. region.

Saturated 3-ketones are most reactive towards hydrazone formation with 2,4-dNPH and Girards reagents, but -4-ene-3-ketones and 17 or 20 ketones rather less so. The 11-ketone is inert towards these reagents for reasons of steric hindrance.

Reduction of 3-ketones with  $\text{NaBH}_4$  gives the 3a-OH in the case of a 5b configuration, and the 3b-OH with the 5a configuration (Gaylord, 1956). Both the ketone and the double bond of the 4-ene-3-one function are susceptible to  $\text{NaBH}_4$  reduction (Sondheimer *et al*, 1954) yielding a 4-ene-3b-ol as the major product. In the present investigation reduction of the 4-ene-3-one group resulted in the formation of two derivatives. The major product was the less polar -4-ene-3b-ol with loss of the fully saturated 5a-H-3b-ol (see chapter 3). Reduction of 11 ketones is reported to be slow (Klyne, 1953) and gives the axial 11b-alcohol (Oliveto and Horshberg, 1953). However, in the present investigation, the reduction with  $\text{NaBH}_4$  in 80% aq. tert.-butanol of 11-ketone-c-19 steroids, oxygenated at c-3 and c-17, proceeded rapidly at room temperature, in good yield (2 hours. Approx. 50% reduction in 10 minutes). Reduction of 17 ketones with  $\text{NaBH}_4$  is known to proceed smoothly to give 17b-hydroxylation exclusively (Norymberski & Woods, 1955). The direct formation of a 17a-ol from a 17-ketone has not been achieved by chemical means. However, with reduction of the 16a,17a oxide, the 17a-ol is formed in good yield (Heusser *et al*, 1950b). Reduction of 20-ketones with complex metal hydrides yields mainly the 20b-ol (Klyne, 1953).

#### 1.3.2.2 Reactivity of the corticosteroid alcohol groups

Compounds representative of all four isomeric 3-alcohols are found among the adrenal and urinary

steroids. Separation of 3a and 3b-ols, in either c-5-H series may be achieved by formation of the insoluble digitonides with the steroid (Butt, 1948) containing a free 3b-ol group - trans to the c-10 methyl group (Frane, 1944; Fieser and Fieser, 1949). However 5a-H-3b-ols are precipitated more completely than those of the 5b-H series (Haslam and Klyne, 1953). Moreover, some 3b-ols are not precipitated and some 3a-ols can form insoluble digitonides. Therefore data obtained from this reaction can not be given as conclusive evidence. Other steroidal alcohols do not react with this saponin.

The beta oriented 11-hydroxyl is subject to a much greater steric interference than the 11a-configuration and is almost completely inert to acetylation reagents (Kemp et al, 1954), whereas other steroidal alcohols, except most 3° ones, are easily acetylated. Because of the steric interactions involved, the 11b-hydroxyl is the most easily oxidised of all the 2° steroid alcohols, when using chromic anhydride (Schreiber & Eschenmoser, 1955) and the 11b-alcohol group has even been found to be oxidised by atmospheric oxygen if left to stand at 45°C (Bush and Ferguson, 1955). The -21-ol-20-one (α-ketol) group is responsible for the reaction of corticosteroids having the dihydroxyacetone side chain moiety, with blue tetrazolium salts.

In biological systems the predominant triol is the 17a,20b,21-triol. This triol may be prepared almost pure by a complex metal hydride reduction (Norymberski, 1955). Inversion of configuration at c-20 by an acetylation and tosylation displacement reaction, affords a pathway for the synthesis of the 20a-ol (Fukushima et al, 1956). Normal acetylation conditions applied to the triol side chain gives the 20,21-diacetate.

### 1.3.3. Stereochemistry and biological activity

The steroid nucleus is a rigid structure, stable both chemically and biochemically. The stability of

the nucleus is demonstrated by the absence of  $c^{14}O_2$  in exhaled gases after administration to the higher animals of steroid labelled in the nucleus carbon. However steroids do not accumulate in the soil and appear to be degraded by the organisms present to smaller carbon compounds. The shape of the nucleus is relatively unaffected by substituents. Bulky groups substituted in axial positions, rather than equatorial, may considerably influence the reactivity of regions of the nucleus remote from the substituent - probably through minute changes in shape of the molecule.

As functional groups are located at opposite ends of the molecule it must lie flat along the steroid receptor unit making contact along its almost planar b-face. Substitution of an 11 $\alpha$ -hydroxyl group for the 11 $\beta$ , will inactivate the steroid. Axial positions are at right angles to the molecular plane and large bulky groups here can reduce or abolish activity especially if attachment is to the b-face. Some interaction with groups attached to the 'side' of the steroid molecule has been noted in the case of estradiol and testosterone.

Evidence therefore, points towards a steroid receptor site in the target tissue requiring a specifically shaped molecule for activation. This conforms with the lock and key hypothesis of Ehrlich for drugs and their receptors, when applied to steroid hormone biochemistry.

#### 1.4 The Metabolism of Cortisol

Due to the many chemically reactive areas of the cortisol molecule there are a multiplicity of possible modifications that may occur. The presently available information pertaining to the catabolism of cortisol indicates a sequential reduction of the whole molecule and oxidative removal of the two - carbon side chain. Furthermore, the substituents in other parts of the molecule may have considerable effect on the stereochemistry of the metabolites produced.

#### 1.4.1 Reduction in Ring-A

##### 1.4.1.1 Reduction of the 4,5-double bond

For practical purposes the reduction of the c4-5 double bond is an 'irreversible' reaction and may be a principal determinant of the secretion rate of cortisol (Ungar *et al*, 1954). The reduction of this double bond results in loss of the characteristic biological activity of cortisol - although the 5a and 5b reduced steroids do have pharmacological actions, although they are distinct from those of their unsaturated parent compounds. Synthetic steroids with high biological activity have groups attached to the steroid nucleus in such a way as to impede the 4-5 reduction and subsequent deactivation. The 4,5-dihydro reduction products of cortisol are rapidly converted to the tetrahydro forms. It has been assumed through lack of evidence that the double bond elimination in ring-A, precedes the reduction of the ketone on carbon three.

The main site of reduction is the liver containing the two types of enzyme (1) 5a-4,5ene-hydrogenase (reductase) (5a-R)

(2) 5b-4,5ene-hydrogenase (reductase) (5b-R). In the catabolism of cortisol the 5b-R is predominant in humans with the major products being cortols, cortolones, THF and THE (Axelrod and Goldzieher, 1960; Baulieu and Dray, 1963). The 5a-R produces a small but constant fraction of the total metabolites.

The 5b-THF may undergo further reduction to cortols and then excretion as a conjugate, while the 5a-THF (allo-THF) is conjugated and excreted without further reduction to allocortols, etc. However allocortols and smaller amounts of allocortolones have been isolated from human urine (Fukushima *et al*, 1960) but may be derived from compounds initially reduced in the c-20 ketone, before reduction of ring-A. The concentration of tetrahydro derivatives in the circulation as unconjugated plasma steroid is low.

Both in vivo (Ulrich, 1958) and in vitro perfusion of rat liver (Capsi and Hechter, 1956) resulted in detection of considerable quantities of allo-THF and allo-b-cortols while liver perfusion of the dog liver in vitro produced quantities of THF, THE, and b cortolone (Axelrod and Miller, 1956).

Distinct microsomal 5a-Reductases, and soluble 5b-Reductases are found in liver tissue (Forchelli and Dorfman, 1956). Both require  $\text{NADPH}_2$  ( $\text{NADH}_2$  being ineffective) as co-factor, and transfer of hydrogen appears to be direct and 'irreversible'. Supernatant of rat liver homogenate was found to reduce a wide range of c-19 and c-21 steroids. Although this suggests a lack of specificity of these enzymes the opposite appears to be the case. Tomkins (1957) noted that a purified cortisol-5b-4ene-hydrogenase was unable to catalyse the reduction of cortisone or adrenosterone. Fractionation of the soluble cell contents by different methods gave different ratios of activity between various steroids. In hepatic cirrhosis the activity of the cortisol specific reductase is affected but that of the cortisone specific reductase is unchanged suggesting independence between the reductases. Tomkins (1957) isolated a specific cortisone-5b-R and by 1960 had detected five specific 5a-Reductases (McGuire and Tomkins, 1960). Similar specificity was described for liver microsomes (McGuire and Tomkins, 1959).

It was originally reported that female rat liver contained only microsomal 5a-Reductase (Yates et al, 1958) while the male rat liver contains both the 5a-Reductase and the 5b-Reductase enzymes (Forchelli and Dorfman, 1956). Later however, the 5b-Reductase was detected in female rat liver but with very low activity except during certain periods of the rats life (Forchelli et al, 1963).

In general both microsomal and soluble enzymes reduced 11b-alcoholic steroids to a lesser extent than

those with the 11-ketone, in guinea pig, mouse and rabbit livers. In rat and hamster microsomal preparations, cortisone and cortisol are equally reduced. Furthermore, in guinea pig the major proportion of ring-A reduced c-21's are 11b-alcohols while ring-A reduced c-19's are 11-deoxy or 11-ketone.

The influence of thyroxine is to increase the available NADPH and with chronic treatment gives an increase in the microsomal enzyme concentration only. This was found to be sufficient to influence the 5a/5b ratio (Bradlow et al, 1956).

#### 1.4.1.2 Reduction of the 3-ketone

In humans the major product of reduction of the 3-ketone is the 3a-alcohol, but both 3a and 3b, 3-hydroxysteroid dehydrogenases have been described (Tomkins, 1956; Hurlock and Talalag, 1959). Combined action of these two types, accounts for the hepatic epimerisation of the alcohol on c-3 (Repke and Samuel, 1964).

It has been assumed by lack of evidence that the reduction of the 4,5-double bond in ring-A precedes the reduction of the c-3 ketone. The presence of A-4-ene-3a,11b-ol-17one as well as A-4-ene-11b-ol-3,17-one has been noted in healthy humans and to a larger extent in those with myxedema (Slaunwhite et al, 1964). This suggests that reduction of the 3-keto group can occur in the unsaturated steroid (see 1.4.1.3). On the other hand 3a-hydroxysteroid dehydrogenase (3a-OH-DHase) does combine more readily with the saturated dihydro cortisol metabolite, rather than the unsaturated form, although the enzyme appears to be non-specific as to other structures attached to the steroid molecule, having about the same affinity for cortisone as for adrenosterone (Tomkins, 1956). The enzyme system is freely reversible in purified form, but in vivo the rapid conjugation of the 3-alcohol with either glucuronic or sulphuric acids shifts the equilibrium

almost completely towards the formation of the alcohol. In this respect it is of interest that the 4,5-dihydro-3-ketone metabolite of cortisone was isolated from human urine by Schneider(1952). That this compound may have been formed from the oxidation of the 3-alcohol was supported by the identification of dihydrocortisol as a metabolite of THF (Savard and Goldfaden,1954).

Both the 3a-OH-DHase and the 3b-OH-DHase can associate with either  $NADH_2$  or  $NADPH_2$  as cofactor, although after 50 to 150 times purification of 3a-OH-DHase from *Pseudomonas testosteronei* revealed a distinct preference of this enzyme for the NADH cofactor (Talalag et al,1952). The rat liver has both particulate and soluble enzymes capable of reaction with both 5a and 5b steroids (Ungar,1960). The 3a-OH-DHase was found in the soluble fraction of rat liver, kidney and rabbit liver and kidney, but not in the lung, spleen or muscle (Ungar and Dorfman,1954). It is thought that a single enzyme catalyses the oxidation/reduction of both c-21's and c-19's but the affinities of the enzyme towards various substrates may vary (Tomkins and Isselbacher, 1954) although no reaction with acetone or cyclohexanone was observed. The close physical association between these enzymes is shown by the inability of workers to satisfactorily separate the mammalian (rat liver) 3a-OH-DHase from the 3b-OH-DHase (Hurlock and Talalag, 1958) or the separation of the 3b-OH-DHase from the 3a-OH-DHase (Rubin and Strecker,1961). However the specificity of each enzyme is such that mouse 3b-OH-DHase would not react with the 3a, 3a-4-ene, 3b-5-ene, 11b or 17b alcohols. Similar specificity was obtained with horse liver preparations (Ungar,1960).

Small amounts of 3b-OH-DHase is found in humans and somewhat larger amounts in the dog, but in general, 3b-OH-DHase activity is confined to animals of the lower zoological orders. In man and sheep the principal 3-OH steroids have the 3a configuration. A sex difference in the 3a/3b ratio has been observed in rats, rabbits

and mice but not guinea pigs (Rubin, 1957). The ratio was found to be influenced considerably, by the circulating level of testosterone.

#### 1.4.1.5 Formation of 3-ol-4-ene-steroids

The other than normal route involving initial reduction of the 3-ketone before saturation of the 4,5-double bond has been demonstrated by Thomas and Dorfman (1964). They were able to use rabbit skeletal muscle to transform A-4-ene-5,17-one to the 3 $\beta$ -alcohol. The reverse reaction was demonstrated in rat liver tissue (Ungar *et al*, 1957). The 17-ketosteroid of cortisol was also found to be a suitable substrate for this reaction (Neeman *et al*, 1960). The enzyme appears to have dual nucleotide specificity and is found in the soluble fraction of the liver.

#### 1.4.2 Side Chain Cleavage

Removal of the labile two carbon side chain of cortisol metabolites has been studied *in vivo* in human subjects, and *in vitro* in the rat, dog, and bovine species using muscle, liver and kidney tissues. Although conversion of c-21 steroids to c-19-ketosteroids is of varying importance in most, if not all higher animals and a capability of many micro organisms, little is known of the mechanism or the enzymes required. The significance of this transformation for the economy of higher animals is unknown.

The substrates are almost exclusively the 5 $\beta$ -tetrahydro metabolites and most commonly the cortols and cortolones (Savard and Goldfaden, 1954). This transformation requires that there is no conjugation at c-21-OH before cleavage. The 17-ketosteroids of cortisol and cortisone yield little of the 5 $\beta$ -metabolite and mainly the 5 $\alpha$ -3 $\alpha$ -ol compounds from reduction of ring-A. This eliminates side chain cleavage of cortisol and cortisone as a major pathway to the production of the ring-A reduced, ketosteroid metabolites found in

the human, although the 17-KS of cortisol and cortisone have been found (Fukushima *et al*, 1960).

Lynn and Brown (1958) have investigated enzymatic aspects of the side chain degradation of 17 $\alpha$ -hydroxyprogesterone. The enzyme responsible, a liver 17 $\alpha$ ,20-C<sub>21</sub>-desmolase, required NADPH<sub>2</sub> and oxygen, and was inhibited by metal chelating agents, and may be similar to the cortisol desmolase.

#### 1.4.5 Reduction of the 20-ketone

The reduction of the ketone on carbon-20 of c-21 steroids to give either the 20 $\alpha$ - or 20 $\beta$ -alcohol is for practical purposes 'irreversible' in that the equilibrium generally lies well in favour of the reduced forms. However Ungar and Dorfman have observed the conversion of pregnenediol (20 $\alpha$ -OH) to pregnanalone (20-keto) in humans.

Direct conversion of the c-20-ketone to the isomeric alcohols without prior reduction of ring-A, is considered to be a minor pathway (Bradlow *et al*, 1962) although the production of P-4-ene-11 $\beta$ ,17 $\alpha$ ,20,21-ol-3-one from cortisol has been observed *in vitro* in bovine kidney (20 $\beta$ ) (Canis *et al*, 1956) and in rat connective tissue (20 $\alpha$ ) (Berliner and Dougherty, 1958). Considerable quantities of both the 20 $\alpha$  and 20 $\beta$ , ring-A-unsaturated cortisol derivatives were found in the guinea pig (Burstain and Dorfman, 1955), which is in keeping with the general cortisol metabolism of this animal.

The supernatant of rat liver homogenate was found to produce both the 20 $\alpha$  and 20 $\beta$  isomers (Hubener *et al*, 1956) while mainly 20 $\beta$  cortols and allocortols were isolated from the rat, after *in vivo* administration of cortisol (Ulrich, 1958). Hubener *et al* (1950) found that metabolism of THE and cortisol *in vivo* gave mainly the 20 $\beta$ -OH isomer while THE and 11 DOCortisol resulted in quantities of the 20 $\alpha$ -OH-isomer. A difference between female and male rat livers, with respect to the concentration of the c-20-Dehydrogenase has been

found by Troop(1959). In young rats the presence of estrogens decreased, and androgens increased, the reduction rate. Male rats, therefore, have a greater c-20-one reducing power than female rats although the administration of cortisone decreased this activity in both sexes (Hagen and Troop,1960).

The c-20-Dehydrogenases are widespread throughout the tissues, being found in corpus luteum; ovary placenta adrenal, periferal tissues and the liver. The 20b-OH-Dehydrogenase from hepatic microsomes was found to use NADPH<sub>2</sub> preferentially but can use NADH<sub>2</sub> at one sixth of the rate of NADPH<sub>2</sub> (Recknagel,1957). A specific 20a-OH-Dehydrogenase from rat ovary has a specific requirement for NADPH<sub>2</sub> with no NADPH<sub>2</sub>/NADH<sub>2</sub> transhydrogenase activity. The equilibrium ratio of 20a-OH to 20=O, was 1.7 (Wiest and Wilcox,1961).

#### 1.4.4 Hydroxylation

In general the hydroxylases do not play such an important role in steroid metabolism as do the dehydrogenases. However from the isolation of hydroxylated urinary metabolites, hydroxylation has been shown to occur in positions 2,6,7,15 and 16 (Axelrod et al,1956; Gold,1962).

Hydroxylation is recognised as being important in biosynthetic reactions (e.g. 11b-hydroxylation) in steroid forming tissue, but although demonstrated both in vivo and in vitro, the function of these in hepatic catabolic reactions remains unclear. As yet, the enzymes involved have not been characterised but appear to require NADPH<sub>2</sub> and atmospheric oxygen.

A 2a-hydroxylase is present in guinea pig liver, and 2a-hydroxy-cortisol has been isolated in guinea pig urine (Burstein,1956; Peron and Dorfman,1956).

Since 6b-hydroxylation of a c-19-steroid was reported by Meyer(1955) and 6b-hydroxylation of F was recognised in the human (Burstein et al,1954) and in the guinea pig (Burstein and Dorfman,1955),

6b-hydroxylases for both c-21 and c-19 steroids have been described in many tissues. The principal site of formation is the liver (Cohn et al, 1961) but hydroxylase activity has also been demonstrated in vitro in the kidney and skeletal muscle (Lipman et al, 1962).

Although in a normal human 6b-OH-cortisol represents only a very minor product of cortisol metabolism, in infants and the mother during pregnancy, considerable quantities of 6b-OH-cortisol is present in the urine.

Introduction of the 6b-OH group into the cortisol molecule prevents further metabolism of ring-A, the products resembling some synthetic corticosteroids in this respect. However, probably the most important aspect of 6b hydroxylation is the increase in aqueous solubility conferred on the cortisol molecule by this reaction. The 6b-OH-cortisol is sufficiently water soluble to pass through the kidney without prior conjugation and appears in the urine almost exclusively in the free form. This affords a mechanism whereby excess cortisol in the plasma can be cleared rapidly without reduction or conjugation, and this appears to be the case. It has been observed that an increase in the half life of cortisol will produce more 6b-OH-cortisol, with a concomitant decrease of tetrahydro metabolites in the urine (Bledsoe et al, 1964).

A 6a-hydroxylation has been detected, but is of lesser consequence than the 6b-form (Frantz et al, 1961).

#### 1.4.5 The Cortisol - Cortisone Equilibrium

The reduction of administered cortisone, to cortisol, was observed by Burstein et al (1953) and Burton et al (1953); and the reverse reaction, oxidation of cortisol in vivo, was observed about the same time by Burstein et al (1953). Similar oxidation and reduction reactions were observed in the synovium of arthritic humans (Wilson et al, 1954). The in vitro reduction of the 11-ketone group of cortisone has been demonstrated in porcine, bovine and rat, whole liver tissues

(Fish et al,1953), and in bovine kidney mince (Ganis et al,1956).

Cortisone, the 11-ketone derivative of cortisol is biologically inactive in the absence of the 11b-OH-dehydrogenase, and is incapable of controlling the ACTH secretion. However as a result of this dehydrogenase reaction, cortisone has been shown to have two thirds of the biological activity of cortisol in vivo, with the steady state condition slightly favouring cortisone formation (Bush and Willoughby,1957). This mechanism affords one of the principal determinants of the level of circulating cortisol - the biological half life of cortisol is 90 to 115 minutes (Peterson and Wyngaarden, 1956) which is compared to cortisone, under the same conditions, of 30 minutes (Peterson et al,1957).

The enzyme 11b-hydroxysteroid dehydrogenase (11b-OH-DHase) has been found in hepatic microsomes (Recknagel,1957) and in rat kidney homogenate (Bahesh and Ulrich,1959). The kidney enzyme was associated mainly with the nuclear fraction and the microsomes and appears bound to a cell membrane. It required NADP and was not freely reversible. On the other hand, the microsomal 11b-OH-DHase from rat, guinea pig and bovine liver, was able to exchange hydrogen reversibly using either NAD or NADP (Hurlock and Talalag,1959). The 11b-OH-DHase of human placenta also had low substrate, and nucleotide specificity (Osinski,1960).

The enzyme activity is affected by thyroid hormone levels. In hyperthyroid man, this leads to increased oxidation (Hellman et al,1961); while in rats and other less advanced animals, hyperthyroidism results in increased reduction (Koerner and Hellman,1964). Increased plasma cortisol levels also affect enzyme activity. With an elevation of plasma cortisol concentration, the 11b-OH-DHase operates relatively ineffectively and the major fraction is metabolised as cortisol rather than cortisone (Holmes and Greenaway, 1959; Liddle et al,1958).

Hubener et al(1956) originally reported the necessity of a 4-ene- $\beta$ -one grouping in ring-A for reduction of the 11-ketone group by rat liver 11b-OH-DHase. However a THF/THE equilibrium in humans has been reported (Sarard and Goldfaden, 1954) although Bush and Mahesh (1959) have reported more efficient reduction of the 11-ketosteroids with a cis ring A/ring B configuration. Furthermore the affinity of 11b-OH-DHases for 11-ketosteroids substituted in the 2a position is very low (Bush and Mahesh, 1959).

Differences in the 11b-OH-DHase activity between male rat liver preparations, and those from female rats, has been observed.

#### 1.4.6 Reduction of 17-ketones

The enzyme responsible for this conversion, a 17 hydroxy neutral-steroid dehydrogenase, may be 17a-OH specific (17a-OH-N-DHase) or 17b-OH-specific (17b-OH-N-DHase).

The 17b-OH-N-DHase is the most commonly found of the two enzymes and has been reported in rabbit liver (Schneider and Mason, 1948) and skeletal muscle (Thomas and Dorfman, 1964), dog liver (Elempion et al, 1961), human liver and skin, and bovine erythrocytes. Guinea pig liver and kidney contain two 17b-OH-N-DHases, one being found in the soluble cell fraction and requiring NADP as cofactor, and the other is found in the mitochondrial fraction and requires NAD (Endahl and Kochakian, 1962). The purified soluble enzyme showed some substrate specificity, controlled by the configuration of ring-A (Endahl et al, 1960). The oxidation/reduction reaction controlled by 17b-OH-N-DHase is reversible and in rat tissues the direction of shift in equilibrium is controlled by the pH.

Rabbit liver (Clark and Kochakian, 1947), bovine erythrocyte suspensions and guinea pig liver homogenate (Kochalian and Nall, 1953), all have 17a-OH-N-DHase activity. Epitestosterone (17a-OH) formation

from A-4-ene-3,17-one has been observed in the spermatic vein of young calves (Lindner, 1961).

Of five species studied by Lindner (ox, sheep, man, pig, stallion) only the former two (ox and sheep) were found to possess a 17a-OH-N-DHase, although all were found to have 17b-OH-N-DHase activity. In the sheep 17a-OH-N-DHase activity exceeds that of the 17b-OH-N-DHase activity by approximately three times. Although there was no sex difference in activity of 17a-OH-N-DHase in the sheep, Higeon (1962) suggested the 17a-OH-Neutral-DHase was also used for conversion of aromatic steroid 17-ketones.

### 1.5 Steroid Conjugation

Initially the conjugation of steroids with amino acids and hydrophilic radicals was thought to represent enhancing of their physiological activity by increasing the solubility of the steroid in aqueous solvent (Sobotka and Bloch, 1943). More recently conjugate formation was considered to be a catabolic reaction confined to the liver, and associated with the metabolism and excretion of steroids, but has since been demonstrated in steroid forming tissues such as guinea pig placenta (Levitz et al, 1960), normal human adrenal (Killinger and Solomon, 1965) and bovine kidney tissues (Holcenberg and Rosen, 1965). Steroid conjugates are known to enter direct pathways of steroid biosynthesis (Calvin and Lieberman, 1964) and transformation by the adrenal gland.

The least polar corticosteroid metabolites (ketosteroids) are much more soluble in urine than the concentration produced by their daily secretion (Jacobsohn and Levenberg, 1965). Nevertheless the majority of neutral ketosteroid is excreted in conjugated form as hemiacetals of b-D glucopyranosiduronic acid and as mono-esters of sulphuric acid, suggesting conjugation may be necessary for the transfer of steroid across a biological membrane or to control the availability of free steroid.

The conjugated steroid material in plasma (Crepy

et al,1957) and urine (Kornel,1962) consists mainly of b-glucuronides, but are also bound partially as the sulphate. In addition to glucuronide and sulphate conjugates some unusual forms have been observed e.g. caffeine--steroid complex of human urine (Mishizawa, 1963), corticosteroid-amino acid-complexes (Eades et al, 1954), phosphates (Oertel and Eik-Nes,1958) and conjugates with N-acetylglucosamine (Pasqualini,1967), and others not identified (Paterson et al,1951; Lieberman et al,1954).

Steroid structure has an influence on the type of conjugate formed. The c-19 and c-21 steroids with the 5-one-3b-ol structure are normally excreted as sulphates. (Lieberman et al,1954) while the saturated 5b-H-3a-ol-c-19's and c-21's are excreted as the glucuronide (Nason,1954), as are the estrogens (Katzman, 1954). However a small portion of the saturated c-21 steroids occur as the sulphate (Nason,1954). These general rules are flexible and about half of the 17 OHCS excreted after oral administration of cortisone acetate were conjugated to sulphuric acid, although initially the glucuronide form predominated (Woryaberski, 1953). Cortisone, cortisol and 6b-OH-cortisol, are usually present in urine predominantly as the free steroid. Typically, urinary cortisol distribution in humans is:- Free steroid,-30%; c-21 sulphate,-35%; glucuronide,-5% (Pasqualini and Jayle,1961), and some mixed conjugation of cortisone also occurs.

The role of the liver in the formation of steroid conjugates is clearly established, but cirrhosis of human liver was not found to result in the accumulation of free 17KS'S in plasma or urine (West et al,1951) although in this condition the ability of the liver to synthesise glucuronides (Bongiovanni and Eisenmenger, 1951) and sulphates (Birke and Plantin,1954) is seriously impaired. In hepatectomised animals little conjugation occurs (Berliner and Wiest,1956; Berliner et al,1958) indicating the liver to be the major

conjugation site in most species. Conjugate formation is decreased during pregnancy (Migeon *et al*, 1957; Cohen *et al*, 1958) and in hypothyroidism, and increased in hyperthyroidism.

Metabolism of steroids as a whole leads to a more hydrophilic molecule, but not to such an extent as to be easily displaced from associated protein (Eiknes *et al*, 1954), and filtered from the plasma by the kidney. Steroid conjugates are present in plasma as the sodium or potassium salts, but even so, some binding with serum albumin does occur (Slaunwhite and Sandberg, 1958). Excretion of steroid conjugates by the kidney is similar to creatinine (without reabsorption) in the case of glucuronides (West *et al*, 1951) but clearance of sulphates from the plasma is much slower (Kellie, 1957). Corticosterone is conjugated more rapidly than cortisol but excreted slower. The ratio of free to conjugated corticosteroid excreted in the bile is the same as that excreted into the urine, and probably drain the same metabolic pool (Migeon *et al*, 1956).

The  $\beta$ -glucuronide of tetrahydrocortisol is formed in guinea pig liver microsomes (Isselbacher and Axelrod, 1955) by the transfer of glucuronic acid from uridine diphosphate- $\alpha$ -glucuronic acid (UDPGA) to the steroid alcohol with the liberation of uridine diphosphate (UDP) (Isselbacher, 1956). The transfer is catalysed by the enzyme glucuronosyl transferase, present in liver microsomes.

The proposed presence of a steroid sulphate synthesising systems in the microsome free supernatant of rabbit liver homogenate, requiring ATP,  $Mg^{++}$  and  $SO_4^{--}$  (Schneider and Lewbart, 1956), led to the isolation of the sulphate donor, adenosine -3'-phosphate -5'-phosphosulphate (PAPS) (Robbins and Lipman, 1956). The enzyme catalysing this reaction, sulphokinase, appears in two forms in the soluble fraction of rabbit liver extracts - one for estrogens and one for 3 $\beta$ -OH-steroids (Gregory and Nose, 1957); with no

3 $\alpha$ -OH-steroid-sulphokinase present in this system.

#### 1.6 Steroid/Protein Association in Blood

Interaction of steroids with plasma protein seems to be an important factor in increasing the solubility of steroids in aqueous media and in determining this distribution.

Early reports of steroid (estrogen)-protein interaction in blood, from Brunelli(1934) and Haussler (1936), were later substantiated both in man and other species (Szego and Roberts, 1953). Corticosteroid binding to plasma protein was also observed (Savard *et al*, 1952).

Albumin appeared more effective, *in vitro* than globulins for binding steroids (Eik-Nes *et al*, 1954), while *in vivo* albumin binding occurred only after saturation of the globulins. That whole plasma could bind more cortisol and corticosterone than could be accounted for by albumin alone (Sandberg *et al*, 1957) led to the discovery of another steroid binding plasma protein. Further isolation showed binding of 4-c<sup>14</sup>-cortisol was confined to a non-lipoprotein in the  $\alpha$ -globulin fraction. This  $\alpha$ -globulin was named corticosteroid binding globulin (C.B.G.) by Daughaday (1958) and 'transcortin' by Slaunwhite and Sandberg (1959).

Kinetic data points to only two plasma proteins capable of binding cortisol; viz, albumin, and C.B.G. (Mills, 1962). Serum albumin has a high capacity for steroid binding, with a steroid binding constant that decreases with an increase in the hydrophilic groups on the steroid molecule (Eik-Nes *et al*, 1954). In contrast C.B.G. has by far the greatest affinity for cortisol but is easily saturated.

Changes in protein binding influence not only the plasma cortisol level but also its distribution throughout the tissues. During pregnancy (Gemzell, 1953) or experimental production of an elevated estrogen

level in the blood, a rise in total plasma cortisol was observed. This rise was not accompanied by an alteration in the urinary excretion of glucose, indicating a mechanism for the suppression of the physiological effect of an increased blood cortisol concentration. Although the cortisol secretion rate from the adrenal is reduced in these conditions, the concentration of nonbound cortisol in the blood remains almost unchanged (as a result of enhanced binding of cortisol to C.B.G. through a fourfold increase in binding sites on the C.B.G.) (Hills et al, 1960). From such observations it was concluded that the C.B.G.-F complex is inactive physiologically (Slaunwhite and Sandberg, 1959). Furthermore, a large dose of cortisol (30-400 mgm, I.V.) is metabolised at a rate proportional to the amount bound (70-80% bound), while a "trace" dose of cortisol is metabolised at a more rapid rate (approx. 100% bound) (Sandberg et al, 1957). The calculations of Tait and Burstein (1964), revealed that the hepatic extraction of unbound cortisol was not sufficient to account for the metabolic clearance of the hormone. They suggested a dissociation of the protein-cortisol complex during passage through the liver. Indeed, of the 12 ug of cortisol metabolised per minute in a 45 Kg sheep, one third is derived from dissociated protein-cortisol complex and two thirds from the unbound cortisol pool.

The binding of cortisol by C.B.G. exerts a major influence on the equilibrium concentration of cortisol across capillary barriers (Florini and Buyske, 1961). Hence the low levels of C.B.G. in cerebrospinal fluid explains the lower concentrations of unconjugated 17-OHCS in this fluid (Sandberg et al, 1954). Only unbound cortisol is available for glomerular filtration, although the major portion is reabsorbed (Beisel et al, 1964).

Steroids other than cortisol are bound to C.B.G., but to a lesser extent (Daughaday, 1958). Those

TABLE 1-2

The distribution of total plasma cortisol in the human and sheep

	F-CBG	F-Albumin	Free-F
Human	78%	13%	9%
Sheep	58%	20%	22%

TABLE 1-3

Distribution of total plasma cortisol

	Capacity of CBG $\Delta$ ug(F)/100ml plasma	Total binding capacity of plasma $\circ$ ug(F)/100ml	Plasma-F concn. $\circ$ ug/100ml
Cortisol Human	20 - 30	17 - 23	7 - 10
" plus estrogen Human	90 * †	25 - 59	-
" Sheep	2.4	1.7	0.6-1.1
" Goat		3.5	1.2
" Guinea pig		14 - 21	7 - 9
" Ox		6.1	2.6
11-DOC Human	60		
B "	10		
E "	10		

\* concentration of binding sites =  $2.5 \times 10^{-6}$  M/Litre

† Doe et al (1964)

$\Delta$  Chen et al (1961)

$\circ$  Lindner (1964)

competing most vigorously with cortisol are expressed as a percentage of the ability of cortisol to displace 4-c<sup>14</sup>-F from C.B.G. under standard conditions - 11 deoxycortisol 90%, corticosterone 85%. Cortisone has a very low affinity for C.B.G. binding sites and can displace only 20% of that of cortisol.

Integrity of the 4-ene-3-one conjugated system in ring-A, and the c-20-ketone are essential for full binding. The 11b, 17a and 21 hydroxyls also add to the strength of the C.B.G. bond. The nature of the c-11 oxygen is important - replacement of the 11b-OH by a ketone or 11a-OH group decreases binding affinity considerably. Evidence has been presented by Westphal and Ashley(1959) that the binding takes place between the almost planar alpha surface of the steroid and the C.B.G., permitting access to the 4-ene-3-one function and the c-20-ketone. Some lateral interaction must take place for the c-11 oxygen to influence binding affinity.

Under normal physiological concentrations in peripheral plasma there is no competition between F and B or aldosterone, for binding sites of C.B.G. (Antoniades, 1957), and injection of 0.5 to 0.7  $\mu$ gm of F resulted in complete binding. There was no qualitative difference between exogenous and endogenous steroid (Upton and Bondy, 1958), and steroid-protein formation is considered to be purely a physical process not requiring cellular activity of any tissue other than blood (Daughaday, 1956). Formerly it was believed that intervention of the liver was necessary for steroid-protein formation (Roberts and Szego, 1953).

Corticosterone was found to associate with serum albumin mainly, and also with a- and b-globulins; while F associates mainly with b and a globulins, and very little with albumin. However some individual variation with respect to plasma binding capacity of corticosteroids was observed in both humans and sheep (MacDonald and Riech, 1959).

Blood erythrocytes (R.B.C.) may also bind with

plasma steroids (Bischoff and Katherman, 1948) although they have greater affinity for estrogens than cortisol or corticosterone (Sandberg et al, 1957). Recently corticosteroids have been shown to protect R.B.C. against haemolytic agents (Agarwal and Garby, 1964)- 11 deoxycortisol being the most active in this respect. Affinity of R.B.C. for steroids decreases with increase in overall polarity of the steroid. Fibrinogen and prealbumin have a very low binding affinity for cortisol compared with that of serum albumin.

An investigation of five species (Man, dog, sheep, rabbit, rat) in vitro, revealed that sheep have the lowest, and human sera the highest ( $\times 10$ ) capacity for corticosteroid binding to plasma protein (Riech, 1960) (see, table, 1-2). The total concentration of cortisol in periferal plasma of the sheep is low (Lindner, 1959). The clearance of plasma cortisol in the sheep is more rapid than man (Paterson, 1963) and the half-life of cortisol-20 to 30 minutes in the sheep, is shorter than that of man -90 to 110 minutes. Estrogen administration in the human produces 50% increase in the half-life of cortisol with an associated increase of up to 80% in the binding of cortisol. The ewe show no such changes in the binding characteristics or half-life of cortisol, either by estrogen administration or during pregnancy. At high plasma cortisol levels only about 40% may be bound in sheep blood but binding may be considerably greater at lower plasma cortisol levels. The administration of ACTH causes a sharp decrease in this percentage (Lindner, 1964).

The concentration of albumin-bound cortisol in the sheep was found to be proportional to the concentration of unbound cortisol. The binding constant for a 1% w/v solution of albumin is 85% that of human albumin, however the plasma albumin concentration in the sheep is considerably less than that of man, so overall, there is less albumin bound cortisol in

the sheep (Paterson and Hills, 1967).

The binding constant for sheep C.B.G. was  $0.87 \times 10^8$  L/mole compared with  $0.52 \times 10^8$  L/mole for human plasma C.B.G., (Hills, 1962) but the mean concentration of C.B.G. binding site was equivalent to 24 ug of cortisol / litre plasma (Doe et al, 1964) compared to 200 - 300 ug / litre plasma, for humans (Ohen et al, 1964).

A summary of the distribution of total plasma cortisol in the sheep and man - according to Tait and Burstein (1964) is given in table (1-3).

Artificially induced levels of plasma cortisol, greater than 3 ug/100 ml., resulted in a decrease in wool growth (Lindner, 1959) and metabolic signs of excess cortisol action (Bassett, 1963).

#### 1.7 Ultimate Distribution

The ultimate fate of cortisol and its metabolites, and routes of excretion, varies from species to species. Most carnivores, herbivores and rodents excrete the major proportion of their steroid metabolites in the bile. Primates, the horse, and guinea pigs excrete the major proportion in the urine. Although there are often only small amounts of steroid material in the faces and the majority of that excreted is found in the urine, the biliary route may still be of considerable importance. Large amounts of steroid may be excreted through the bile and be reabsorbed via the portal circulation (possibly after bacterial modification) to be again excreted either in the bile or urine, constituting an enterohepatic recirculation (Hyde and Williams, 1954).

The half-life of cortisol and its metabolites in the tissues appears to be very short (Bradlow et al, 1954). No mention of cortisol by periferal tissues was observed in man, even in severe inflammation (Nelson et al, 1951). Some localisation of tritium labelled cortisone in the liver has been reported in rats (Bradlow et al, 1954) and man (Plager et al, 1954).

Adrenalectomy has no effect on the disposal of 4-c<sup>14</sup>-cortisol in the mouse or in man (Hellman et al, 1954).

Species differences in the route of excretion of labelled cortisol has been demonstrated. The major pathway in man is via the kidney with only traces found in the feces after 2 - 4 days following I.V. administration (Hellman et al, 1954). In rodents the biliary and fecal routes are important, although the route of administration of the labelled compound has a deciding effect on the ultimate fate. Intramuscular, intragastric and subcutaneous administration resulted in excretion mainly in the bile, while intravenous administration of tritiated cortisone resulted in greater excretion of label in the urine than feces (Bradlow et al, 1954).

--- /- / ---

## Chapter 2

MATERIALS AND EXPERIMENTAL METHODS2.1 Materials

Chemicals used throughout this study were reagent grade, obtained from British Drug Houses L<sup>td</sup>., or May and Baker L<sup>td</sup>., unless otherwise specified. A collection of pure steroids, beta-glucuronidase, phenolphthalein glucuronide, and blue tetrazolium, were obtained from Mann Research Laboratories Inc., New York, U.S.A..

Solvents were distilled before use unless special treatment was indicated.

2.2 Preparation and Care of Experimental Sheep

Romney ewes of 30 - 40 Kg were kept indoors in restraining crates fitted with headstocks to restrict movement. Body slings were used to support the sheep when resting. Feed consisting of equal weights of chaff and sheep-nuts was given once a day at 10.00 a.m., and drinking water was available at all times. For urine collection, the bladder was catheterised with a N<sup>o</sup> 14 Foley catheter left in situ for the duration of the experiment.

In cases where bile was collected the following surgical modifications were made under Fluorthane anaesthesia:

(a) ligation of the bile duct below the branch to the gall bladder, and above the point of entrance of the pancreatic duct,

(b) insertion into the gall bladder of a cannula which was passed out through the abdominal wall.

(c) similar cannulation from the duodenum to the exterior.

Between experiments an exterior bypass tube was used to allow secreted bile to flow directly into the duodenum.

## 2.3 Collection and Preservation of Samples

### 2.3.1 Urine

The end of the urinary catheter was fed through the neck of a 2.5 litre jar, and adjusted to dip under the surface of 150 ml of 95% ethanol. The urine was stored at 0°C until required.

### 2.3.2 Bile

Bile was collected in a 1 litre bottle by interruption of the gall-bladder to duodenum bypass tube. During the bile collections, precollected bile (refrigerated) was pumped into the duodenum at the rate of 10 ml./hour with a peristaltic pump. No preservatives were added, but the bile was stored at 0°C until required.

## 2.4 Extraction of Steroid Conjugates from Sheep Urine

The urine (typically 500 ml. for a 24 hour collection, and containing 150 ml. alcohol) was washed into a large beaker with saturated  $(\text{NH}_4)_2\text{SO}_4$  solution (100 ml.), and solid  $(\text{NH}_4)_2\text{SO}_4$  (350 Gm) dissolved by warming to 35-40°C. The urine was then cooled to 10-15°C and brought to pH 1.0-1.5 with 10 N HCl (65 ml.). This solution was washed into a 5 litre separating funnel with 450 ml. of peroxide free ether. The mixture of solvents was able to be shaken vigorously for 10 minutes without the formation of a stable emulsion, and 10-15 minutes was sufficient for the phases to separate. The aqueous phase was withdrawn for extraction with more diethyl ether / ethanol (3:1, 600 ml.). This second treatment should produce precipitation of  $(\text{NH}_4)_2\text{SO}_4$ . Following a third extraction with diethyl ether / ethanol (3:1, 600 ml.), the organic solutions of steroid conjugates were pooled and the ether and ethanol removed in vacuo, below 35°C.

The first 24 hour collection of radioactive urine was subjected to a fourth extraction with butanol (130 ml.). The butanol was removed in vacuo at 35°C, and the conjugates were redissolved in absolute ethanol (20 ml.).

Any  $(\text{NH}_4)_2\text{SO}_4$  that may have been extracted with the butanol is removed in this step. The steroid conjugates are recovered from the alcohol by evaporation in vacuo, below  $35^\circ\text{C}$ .

To determine the radioactivity remaining in the urine after the extraction procedure, 20 ml. was refluxed for 25 minutes with 1 ml. of 10 N HCl. The liberated steroid was extracted with  $5 \times \frac{1}{2}$  volumes of  $\text{CHCl}_3$ , and the radioisotope recovered from the combined extracts determined.

A summary of extraction efficiency realised by this method is presented in table, 2-1.

## 2.5 Hydrolysis of Steroid Conjugates

### 2.5.1 Assay of b-Glucuronidase

The assay for b-glucuronidase is similar to that described by Levvy and Conchie(1966), using phenolphthalein glucuronide as the substrate.

The assay components consist of :-

phenolphthalein glucuronide solution	- 0.005 M
and adjusted to pH 4.5.	0.1 ml.
Acetate buffer, pH 4.5 - 1.0 M	0.2 ml.
Enzyme solution (pH 4.5)	0.1 ml.
Distilled water	0.1 ml.

For the preparation of a standard curve the substrate and enzyme were replaced with phenolphthalein solution giving up to 100 ug of phenolphthalein in a total volume of 0.5 ml.

The mixture was incubated for 1 hour at  $37.5^\circ\text{C}$ , and the reaction was then stopped by the addition of 5.5 ml. of alkaline glycine reagent. (glycine - 16.3 Gm, NaCl - 12.65 Gm, and NaOH - 5.45 Gm in 2 litre of distilled water. This buffer has a pH of 10.2.)

The liberated phenolphthalein was measured at 550 mu., in a Hitachi 101 spectrophotometer. All readings were measured against a blank - without either substrate or enzyme.

The enzyme activity in each assay is expressed in Fishman units - 1 unit is equivalent to 1  $\mu$ g of phenolphthalein liberated in 1 hour at 37.5°C.

### 2.5.2 Optimum pH of Paua b-glucuronidase

The optimum pH of b-glucuronidase from the Paua can be seen by reference to fig. 2.1. Acetate buffers were used throughout and the pH verified with a pH electrometer before substrate (phenolphthalein glucuronide) was added. Final buffer strength was approximately 0.5 M with respect to acetate.

### 2.5.3 Protein Precipitation from Paua Stomach Homogenate, using Methanol

The homogenate was subjected to methanolic concentrations up to 80%, and the precipitated protein measured.

The homogenate was diluted with an equal volume of water and centrifuged for 5 minutes at 6,000 r.p.m. in a Wifug bench centrifuge. The clear supernatant had a protein concentration equivalent to 24 mgm of serum albumin per ml.. Aqueous methanol was added to 0.5 ml. aliquots of the supernatant producing a range of methanol concentrations from 0 - 85%. These were kept at 0°C for 3 hours before centrifuging at 6,000 r.p.m. for 5 minutes. The supernatant was discarded. Each precipitate was washed with the appropriate concentration of aqueous methanol, then centrifuged at 6,000 r.p.m. for 10 minutes. The supernatant was rejected and the precipitated protein redissolved in 2 ml. of distilled water. Aliquots of 20, 25, and 50  $\mu$ L. were assayed by the Folin-Ciocalteu procedure.

To each aliquot, 3 ml. of 0.01%  $\text{CuSO}_4$  in 0.1 N NaOH was added, and this was stood for 10 minutes. Folin-Ciocalteu reagent (B.D.H. Eng.), 0.3 ml., was added to the mixture and after 45 minutes the optical density was measured against a blank of 700 mu. in

Fig 2.1

Optimum pH for maximum activity of para stomach  
 $\beta$  - glucuronidase

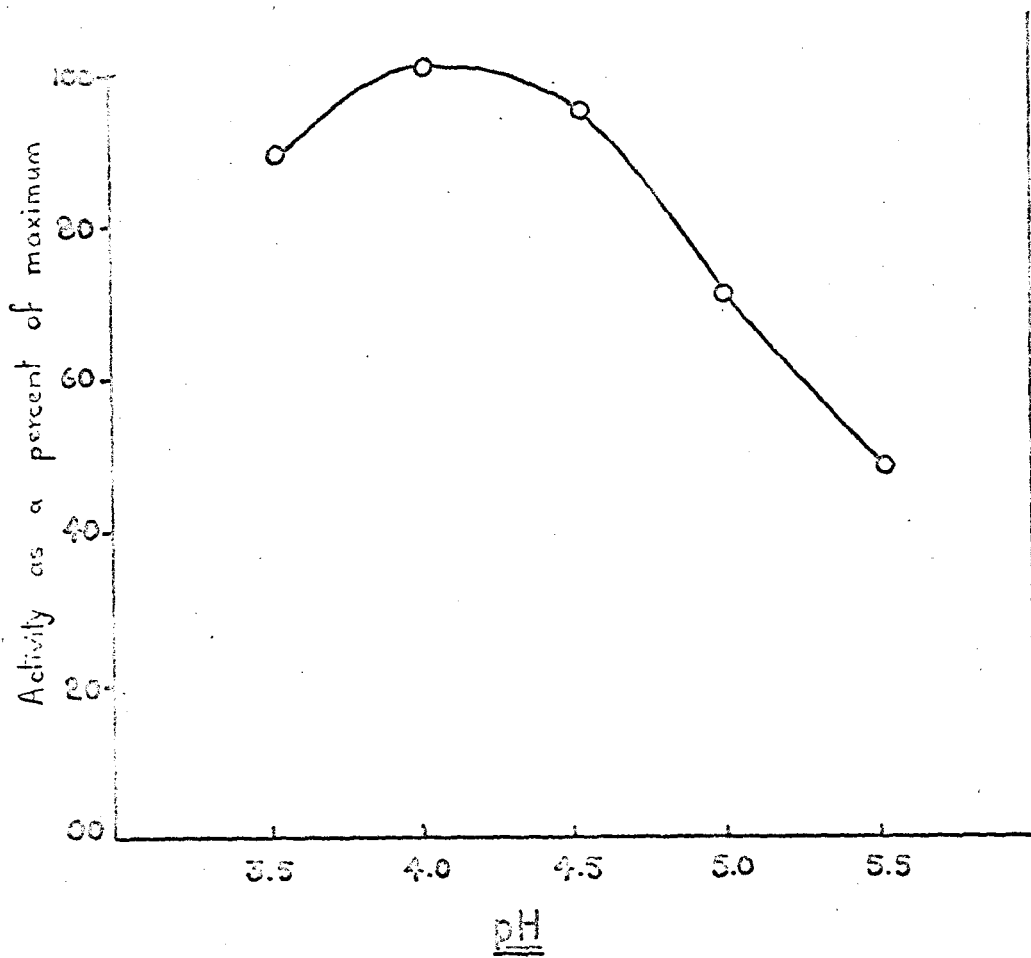
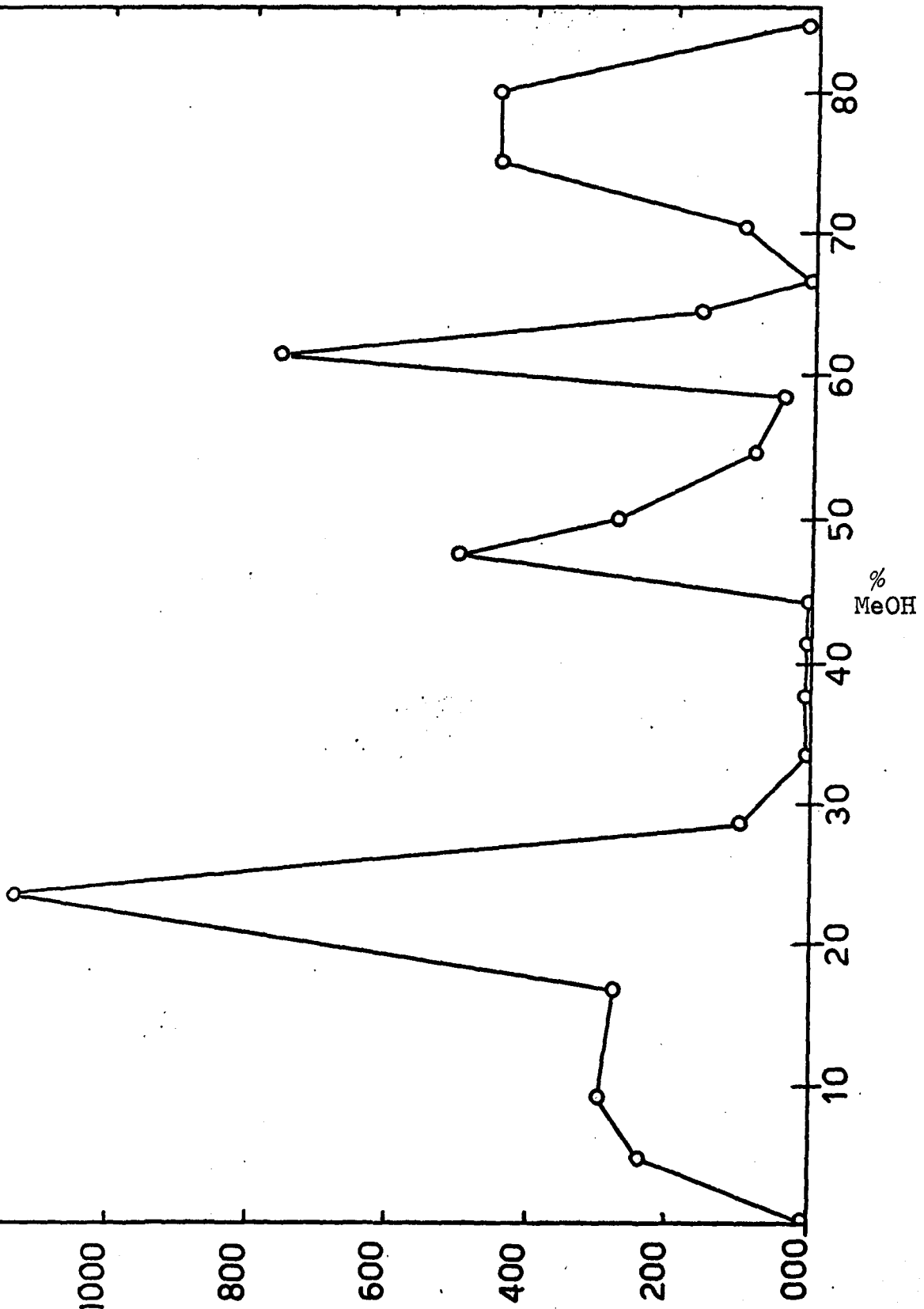

TABLE 2-1

Efficiency of extraction of steroid conjugates from  
sheep urine using ethanol/ether

	Extraction number			
	1	2	3	4
Radioactivity recovered at each step as a % of total recovery	86	11	1.5	0.5

FIG 2.2



mg - protein precipitated from 1ml. homogenate

Protein precipitation from paua stomach homogenate

a Hitachi model 101 spectrophotometer. A standard curve using up to 150 ug of serum albumin was prepared to express the protein precipitated as equivalent to ug of serum albumin per 0.1 ml. of the final protein solution (Fig. 2.2).

#### 2.5.4 Partial Purification of Paua Stomach b-Glucuronidase

The paua, without shell and foot, was collected fresh from a food processing company and the stomachs and intestine only were retained. These were homogenised in a Waring blender for 5 - 10 minutes with an equal quantity (v/v) of water. This homogenate was stored deep frozen until required. The enzyme activity at this stage, when extrapolated to infinite dilution, was 5,700 u/ml.

Two methods were used for further fractionation. An ammonium sulphate method (Lovvy and Conchie, 1966), and a method based on alcohol precipitation.

##### (a) Ammonium sulphate fractionation

The homogenate was thawed, diluted with an equal volume of water and then centrifuged at 1,500 G for 15 minutes. This left a clear yellow / green supernatant which was retained. The pH at this stage was 5.2 - 5.5 and was not altered. This was brought to 20% saturation with  $(\text{NH}_4)_2\text{SO}_4$ , and after allowing to stand for 30 minutes at  $0^\circ\text{C}$ , centrifugation at 1,500 G for 15 minutes gave a clear pale yellow supernatant. This was brought to 80% saturation with  $(\text{NH}_4)_2\text{SO}_4$  and the temperature held at  $0^\circ\text{C}$  for 30 minutes. The sediment recovered from centrifugation at 10,000 G for 15 minutes was redissolved in 0.01 M acetate buffer (pH 4.7), and dialysed against the same buffer for 24 hours. The enzyme was stored at  $0^\circ\text{C}$ .

This fractionation gave poor recovery of activity, and was replaced by the following procedure developed

Purification of paua  $\beta$ -glucuronidase

Fig 2.3

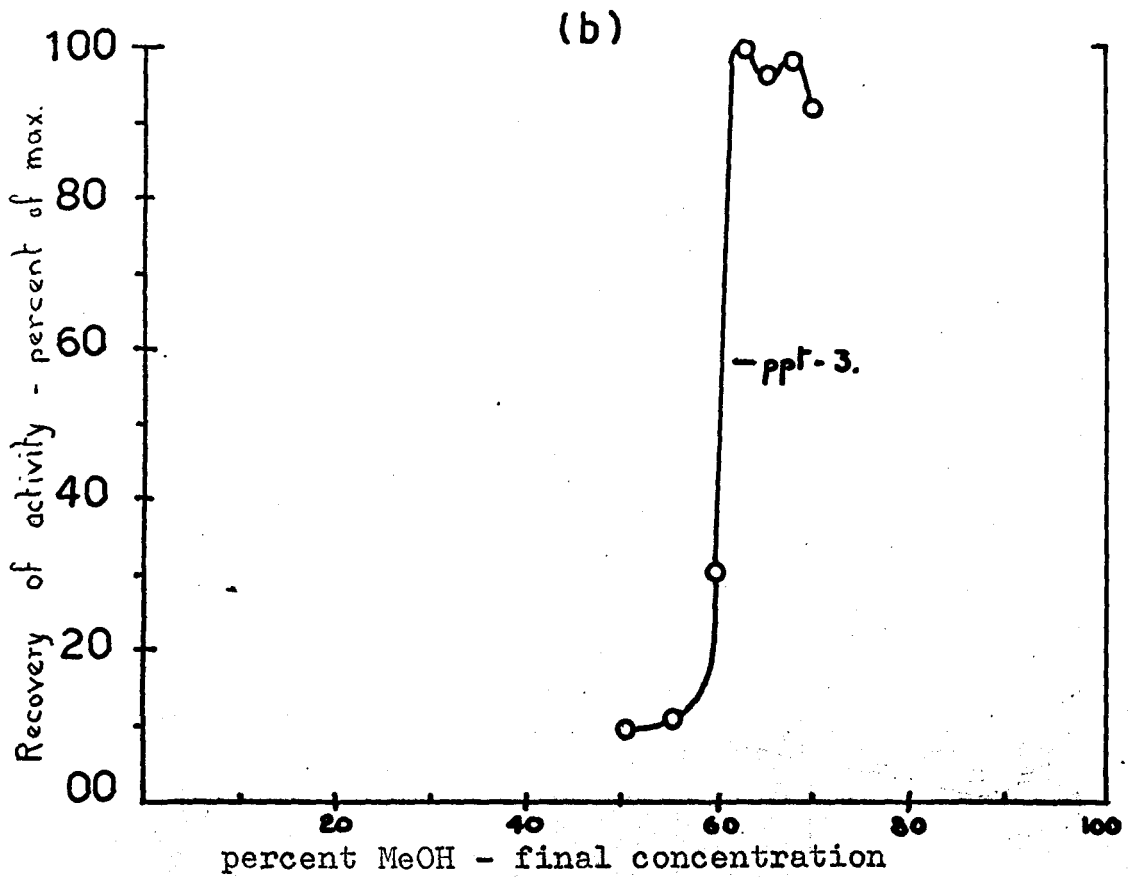
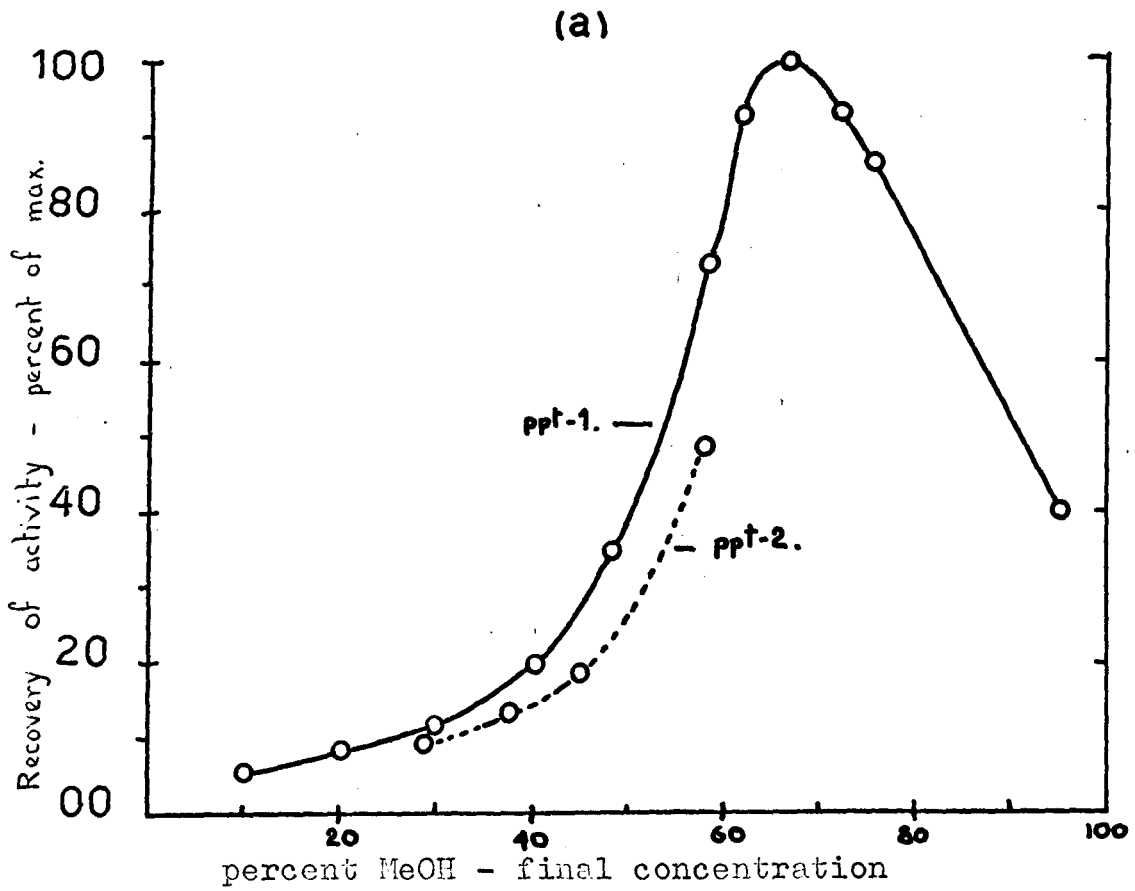

during the course of this study.

(b) Alcohol (Methanol) fractionation - A standardised procedure for the preparation of paua b-glucuronidase

The homogenate was diluted with an equal volume of water and centrifuged at 10,500 G for 15 minutes. The solid residue (20% by volume) was discarded, and distilled methanol was added to the supernatant until the methanol concentration was 10%. After centrifuging at 12,000 G for 5 minutes the supernatant was adjusted to 45% methanol before centrifuging at 15,000 G for 10 minutes. The supernatant was then carefully increased to 62.5% methanol and stood for 12 hours at 2°C. The sedimented enzyme was collected by centrifugation at 18,000 G for 10 minutes (see fig. 2.3a, 2.3b).

The enzyme obtained from 1 litre of homogenate was dissolved in 60 ml. of 0.01 M acetate buffer, pH 4.7, and deep frozen (activity obtained was 40,000 u/ml. - 350,000 u/ml., vide infra).

The b-glucuronidase activity of both the stored homogenate and the partially purified enzyme was found to increase almost tenfold on keeping for 6 months -- from 2,500 recoverable Fishman units / ml. of homogenate, to 22,000 u/ml. of homogenate.

2.5.5 Partial Purification of Limpet b-Glucuronidase

The whole (deshelled) animals, were homogenised and subjected to the same alcohol fractionation procedure as the paua homogenate. The limpet homogenate contained 800 units / ml. (extrapolated to infinite dilution), and the activity of the final preparation, in pH 4.5 buffer, was 24,000 units/ml..

2.5.6 Enzymic Hydrolysis of Steroid Conjugates

The action of Paua b-glucuronidase on urinary corticosteroid conjugates was tested as follows :

B-glucuronidase enzyme from both limpet and paua were used in various concentrations. Labelled steroid conjugates were extracted from sheep urine in the usual way, following administration of 4 - c<sup>14</sup> - cortisol, I.V. to the sheep. The labelled corticosteroid conjugates were redissolved in 0.5 M acetate buffer, giving a final concentration equivalent to <sup>1</sup>/200 of a 24 hour collection, per ml..

#### 2.5.6.1 Hydrolysis of Extracted Conjugates, in Buffer

Sufficient paua enzyme was added to 1.5 ml. of mixed c<sup>14</sup> - corticosteroid conjugates in buffer (acetate, pH 4.6) to bring the enzyme concentration to 12,000; 6,000; 2,000; and 500 units /ml.. A single concentration of limpet enzyme (6,000 units /ml.) was also prepared. The mixtures, in glass stoppered tubes, were incubated at 37°C, with occasional shaking. Over 48 hours of incubation none of the mixtures fell below pH 4.4. Samples of 0.1 ml. were taken at appropriate intervals, and processed immediately.

The 0.1 ml. sample was diluted with 3.0 ml. of chloroform in a glass stoppered centrifuge tube. After shaking vigorously for 30 seconds, 0.25 Gm anhydrous sodium sulphate was added, and the shaking continued for a further 10 seconds. The dried chloroform was cleared by centrifugation and transferred to vials for measurement of radioisotope extracted. (see fig. 2.4.)

This extraction procedure was found to extract negligible amounts of steroid conjugate from solution, as was verified by performing the procedure twice on a sample of steroid conjugates in buffer. After a small amount of free steroid had been extracted with the first treatment, negligible radioisotope was extracted with the second.

#### 2.5.6.2 Hydrolysis of Extract Conjugates, in Urine

Freshly collected sheep urine, without preservative,

FIG 2.4

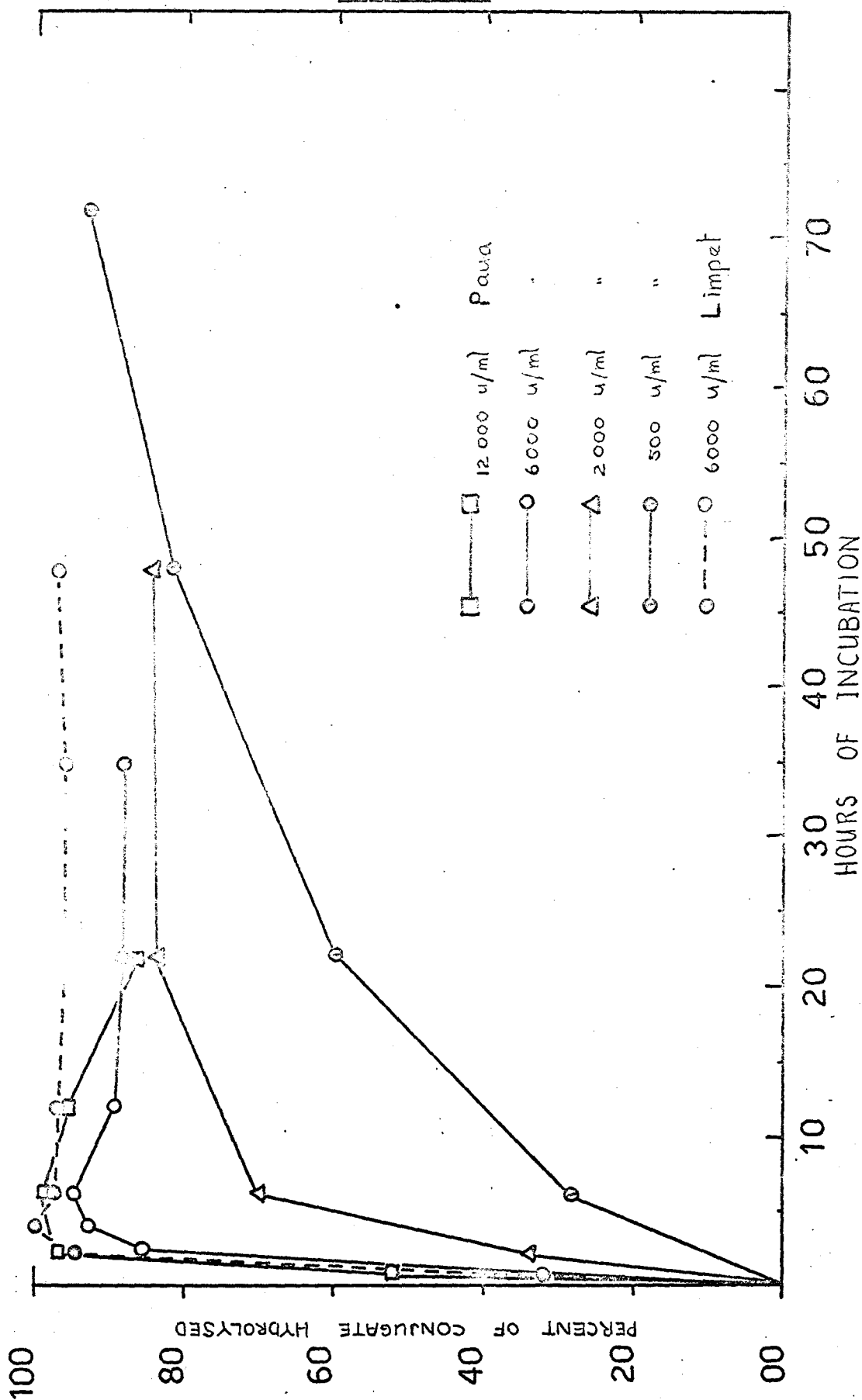

Release of free steroid from the urinary steroid conjugate extract with  $\beta$ -glucuronidase

Fig 2.5

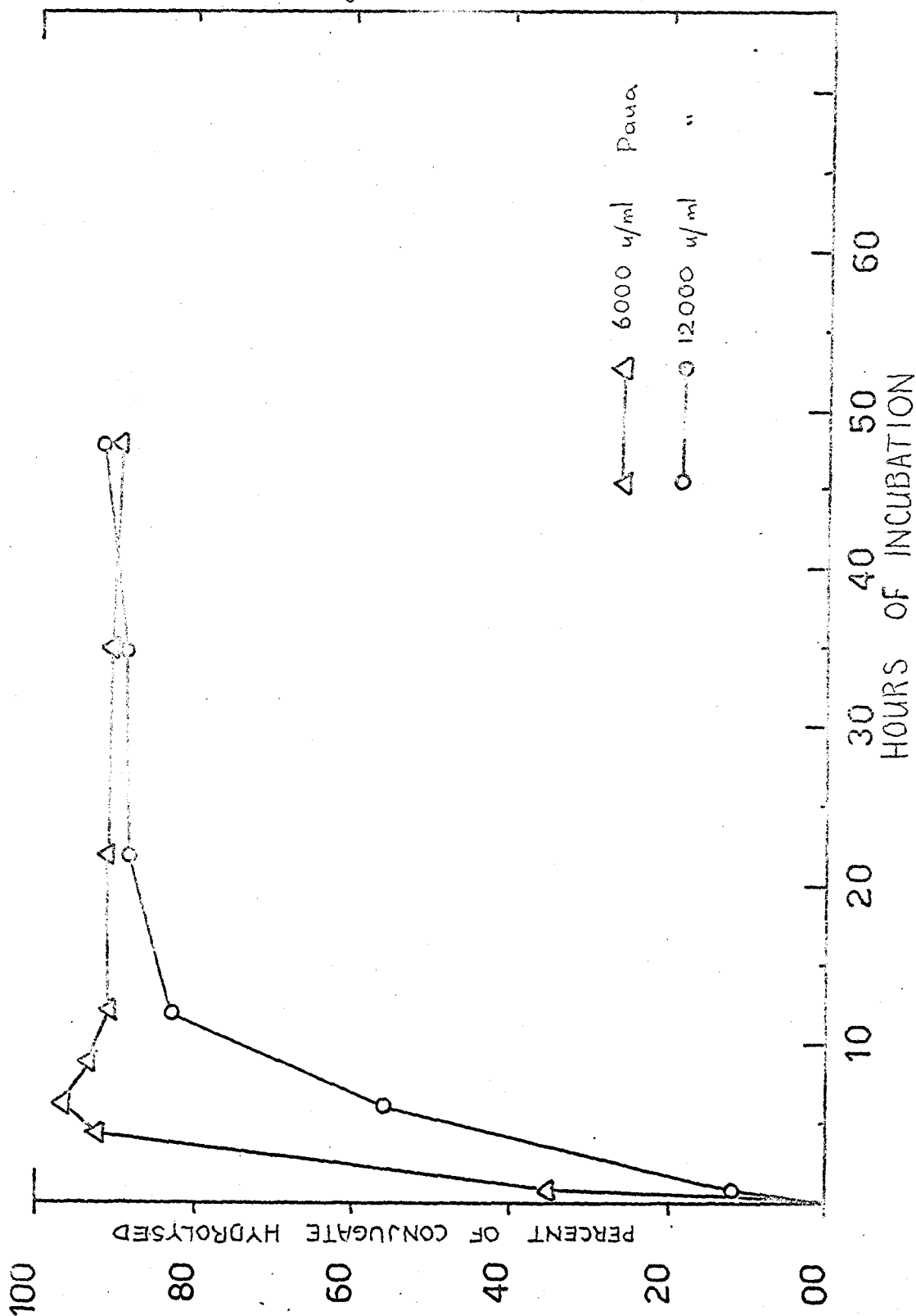

Release of free steroid from the urine with  $\beta$  - glucuronidase

was adjusted to pH 4.6 with hydrochloric acid. In each of two stoppered flasks, 10 ml. of urine was diluted with 9 ml. of 0.5 M acetate buffer. The radioactive conjugate solution (1.0 ml.), and sufficient pure  $\beta$ -glucuronidase enzyme solution to bring the mixtures to (a) 6,000 units /ml. and (b) 600 units /ml. was added to each flask. Both solutions were incubated for 48 hours at 37°C with 1.0 ml. samples being withdrawn at convenient intervals as in 2.5.6.1.

Each 1.0 ml. sample was diluted with 5.0 ml. of chloroform and shaken for 30 seconds. After the two phases had separated, the lower layer was withdrawn and dried with 0.25 Gm anhydrous sodium sulphate. The labelled steroid present in the chloroform was quantitated as in 2.5.6.1 (see fig. 2.5).

### 2.5.6.3 A Standardised Procedure for Enzymic Hydrolysis

As a direct result of these preliminary studies, the following hydrolysis conditions were used throughout.

The steroid conjugates from a 24 hour collection were redissolved in 150 ml. of 0.5 M acetate buffer (pH 4.6) in a 500 ml. flat bottomed flask, containing 2 - 3 Gm of finely divided kieselgur powder to absorb precipitated lipid material. Sufficient enzyme solution was added to give a concentration of not less than 5,000 Fishman units /ml. The mixture was incubated for 8 hours at 37.5°C with occasional shaking.

### 2.5.7 Acid Hydrolysis of Steroid Conjugates

Preliminary work involved the use of the acid hydrolysis technique favoured for clinical determination of urinary ketosteroids. This method although rapid, and non selective for the form of conjugation, has an undesirable destructive action on the side chain of corticosteroids.

The urine was brought to pH 1 by the addition of 10% (v/v) conc. HCl. The solution was boiled for 10 minutes and then quickly cooled. The released steroids

were extracted with 3 x equal volumes of chloroform without neutralisation of the urine.

## 2.6 Extraction of Neutral Free Steroid from Aqueous Solution

A system of extraction using two solvents is presented in this section. The first solvent used has a non-polar characteristic and will extract, chiefly the more non-polar steroids. The recovery of cortisol metabolites in this extract will give some indication therefore, of the nature of the metabolites present. In the case of this present study the cortisol metabolites are in the main, polar to very polar, so in subsequent extraction procedures this first step using benzene/hexane (1:1), was omitted.

The incubation mixture (150 ml., pH 4.5, see 2.5.6.3) containing free steroid absorbed into the kieselgur, was initially extracted with an equal volume of benzene/hexane (1:1)(a). The nonaqueous layer was retained and the aqueous layer was diluted with an equal volume of saturated sodium sulphate solution and extracted (5 minutes) three times with an equal volume (300 ml.) of freshly distilled ethyl acetate (b).

(a) The benzene/hexane extract (190 ml.) was washed with 15 ml. of 3 M NaOH in 20% aqueous sodium sulphate, followed by 2 x 15 ml. of 20% sodium sulphate solution. The combined aqueous washings were backwashed with 20 ml. benzene/hexane. The organic solutions were combined and dried. After removal of the solvent in vacuo the free steroid was redissolved in ethyl acetate.

(b) The three ethyl acetate solutions were pooled and washed with 3 M NaOH in 20% sodium sulphate solution (100 ml., plus 50 ml.), followed by aqueous sodium sulphate solution containing 0.25% (v/v) HCl (2 x 50 ml.). The combined aqueous washings were backwashed with ethyl acetate (3 x 50 ml.). All organic solutions were pooled and dried.

The ethyl acetate solutions from (a) and (b) were

Fig. 2.6

Radioactive cortisol metabolites (mainly free steroid) in acetate buffer - pH 4.5

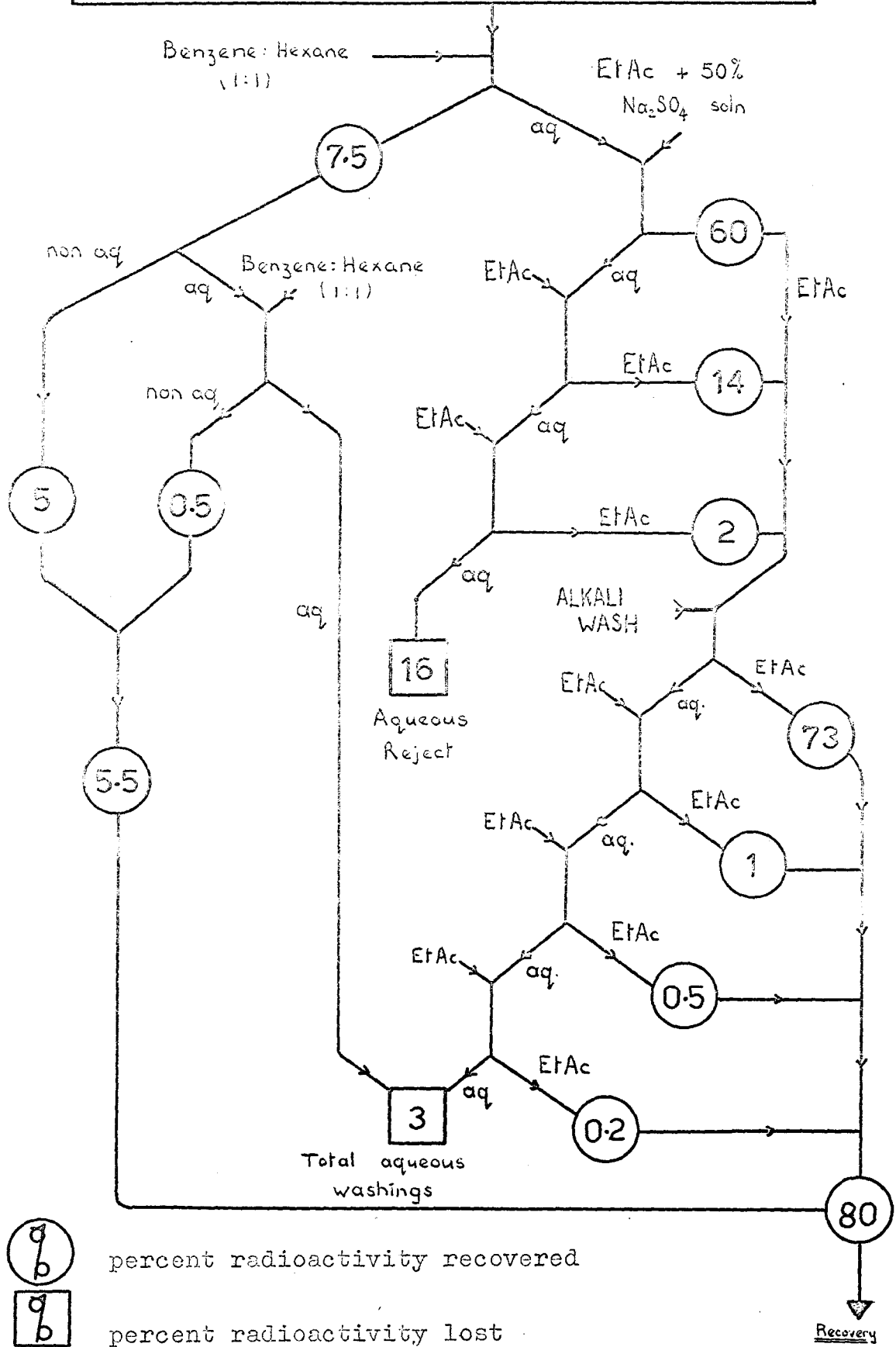

Flow of radioactivity in the extraction of  $c^{14}$ -cortisol metabolites from aqueous solution

filtered before evaporation of the ethyl acetate in vacuo. The red, oily deposit containing the corticosteroids was redissolved in 30 ml. of 5% ethanol in chloroform and refrigerated.

The alkaline aqueous washings, containing the phenolic steroids was discarded.

The scheme for extraction of free neutral steroid from aqueous solution, which shows the recovery of radioactivity at each step as the urine containing 4 - c<sup>14</sup> - cortisol metabolites was processed, is outlined in fig. 2.5.

## 2.7 Steroid Separation Techniques

### 2.7.1 Column Chromatography

Separation of the corticosteroids, from the ethyl acetate extraction, into c-19 and c-21 fractions, was effected using florisil (60/100 mesh (1200°F) Floridin Co., Hancock, West Virginia, U.S.A.) and the modified method of Eik-Nes et al (1953).

The florisil (magnesium silicate) was packed in a large column and washed with distilled methanol until the eluant was no longer milky. After drying, it was activated by heating to 500°C for 4 hours then sealed and stored at 110°C until required.

The column was prepared immediately before use by pouring florisil, slurried in ethanol-free chloroform, to a depth of 10 cm. in a 1 cm. diameter column, 30 cm. long. A 1 cm. layer of finely divided anhydrous sodium sulphate stored at 110°C, was deposited on top of the florisil. As a replacement of glass powder, the sodium sulphate was found very effective in the double function of protecting the column from both water and physical damage.

The head of chloroform was reduced to 0.5 cm. and the mixture to be separated, in a total of about 5 ml. of chloroform, was carefully run on to the top of the column. At a flow rate of 1 ml. per minute good resolution was obtained if the sample occupied no

more than the first 1 cm. of the florisol at this stage.

For the elution of the c-19 fraction, Eik-Nes et al (1955) used 25 ml. of 2% methanol in chloroform, and Ely et al (1958) used only 10 ml. of 2% methanol in chloroform. However, it was found that even 100 ml. of 2% methanol in chloroform was insufficient to elute this fraction satisfactorily (see fig. 2.7).

The following procedure was used to determine the effectiveness of the column system under study. A mixture of 5b-A-3a,11b-ol-17-one (150 ug), cortisol (100 ug), and tetrahydrocortisol (150 ug) in chloroform was placed on a prepared column. A sequence of solvents was applied to the column (see table 2-2) and 10 ml. fractions were collected and assayed as follows:

- (a) 5b-A-3a,11b-ol-17-one was assayed for the 17-ketone present using the Zimmerman reaction
- (b) cortisol was assayed for the  $\Delta^4$ -ene-3-one group present by measurement of the optical density at 241 mu. (in methanol)
- (c) tetrahydrocortisol; the alpha-ketol present in each aliquot was determined by the blue tetrazolium reaction, and the quantity of THF was determined by subtraction of the amount of cortisol (also containing the alpha-ketol group) present, as calculated in (b) above.

The final elution sequence consisted of 30 ml. of chloroform to defat the sample, followed by 100 ml. of 2.5% methanol in chloroform to elute the c-19 steroids, and finally 100 ml. of 25% methanol in chloroform to elute the c-21 steroids (see fig. 2.8). Highly coloured urinary pigments could not be separated from the c-19 fraction, but quantities of very polar non-corticosteroidal compounds, from both bile and urinary extracts, were retained on the column.

A sample of crude radioactive urinary cortisol metabolites in chloroform, equivalent to 10% of a 24 hour collection was eluted off the column and 5% of each 10 ml. fraction was retained for counting (see

TABLE 2-2

Elution characteristics of a Florisil column

RUN	ELUANTS	RECOVERY
1. (fig 2.7)	(a) CHCl <sub>3</sub> - 50ml (b) 2% MeOH in CHCl <sub>3</sub> -100ml (c) 25% MeOH in CHCl <sub>3</sub> -100ml (d) MeOH - 20ml	11OHE, 98% in (b) F, 105% in (c) THF, 93% in (c)
2. (fig 2.8)	(a) CHCl <sub>3</sub> - 50ml (b) 2.5% MeOH in CHCl <sub>3</sub> -100ml (c) 25% MeOH in CHCl <sub>3</sub> -100ml	11OHE, 103% in (b) F, 105% in (c)
3. (fig 2.9)	(a) CHCl <sub>3</sub> - 50ml (b) 5% MeOH in CHCl <sub>3</sub> -150ml	F, found in (b)
4. (fig 2.10)	(a) CHCl <sub>3</sub> - 30ml (b) 2.5% MeOH in CHCl <sub>3</sub> -100ml (c) 25% MeOH in CHCl <sub>3</sub> -100ml	Of metabolites applied to the column - 97%

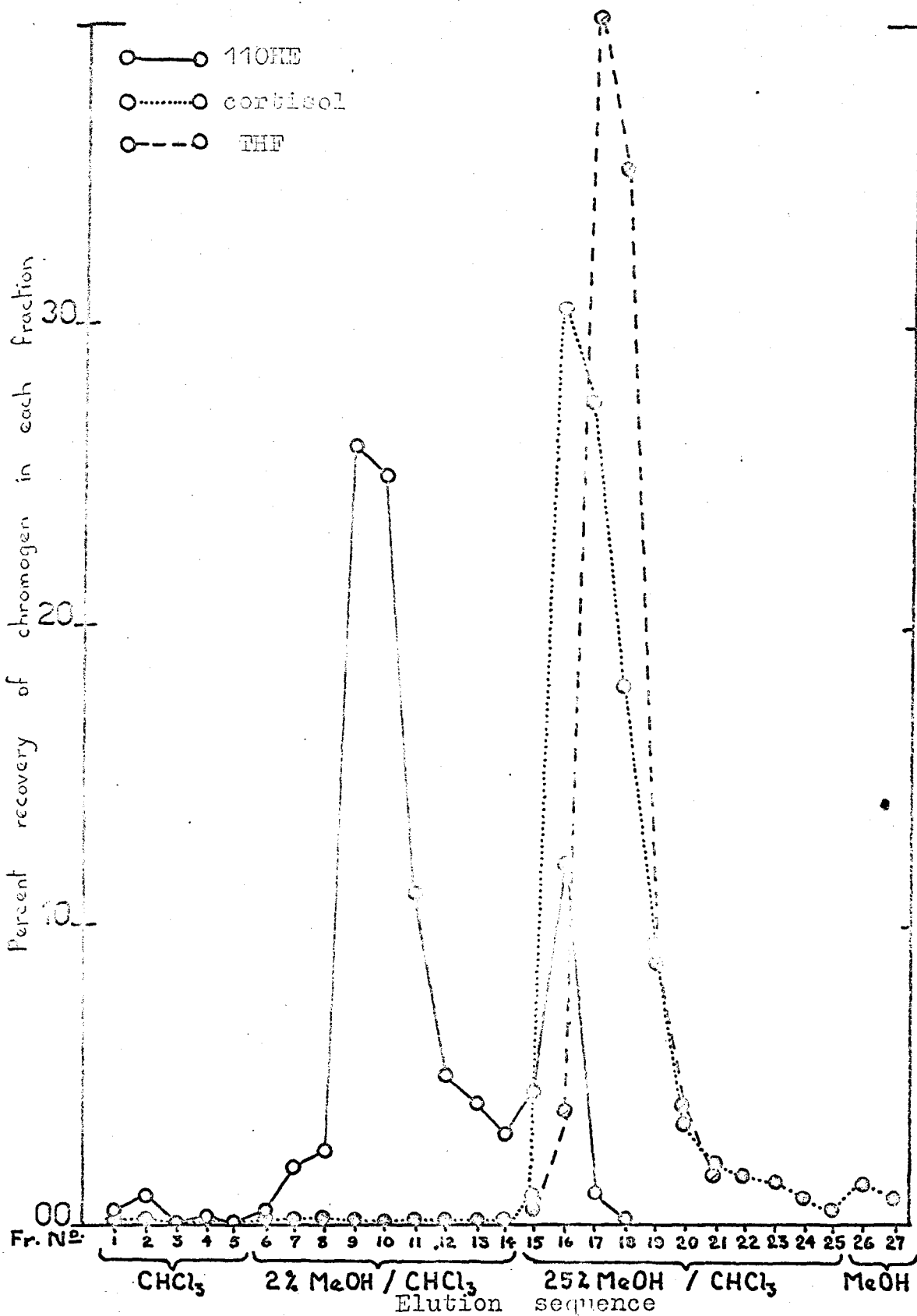

Separation of 11OH-E, cortisol, and THF on a florisil column with 2% MeOH / CHCl<sub>3</sub>

Fig 2.7

Fig 2.8

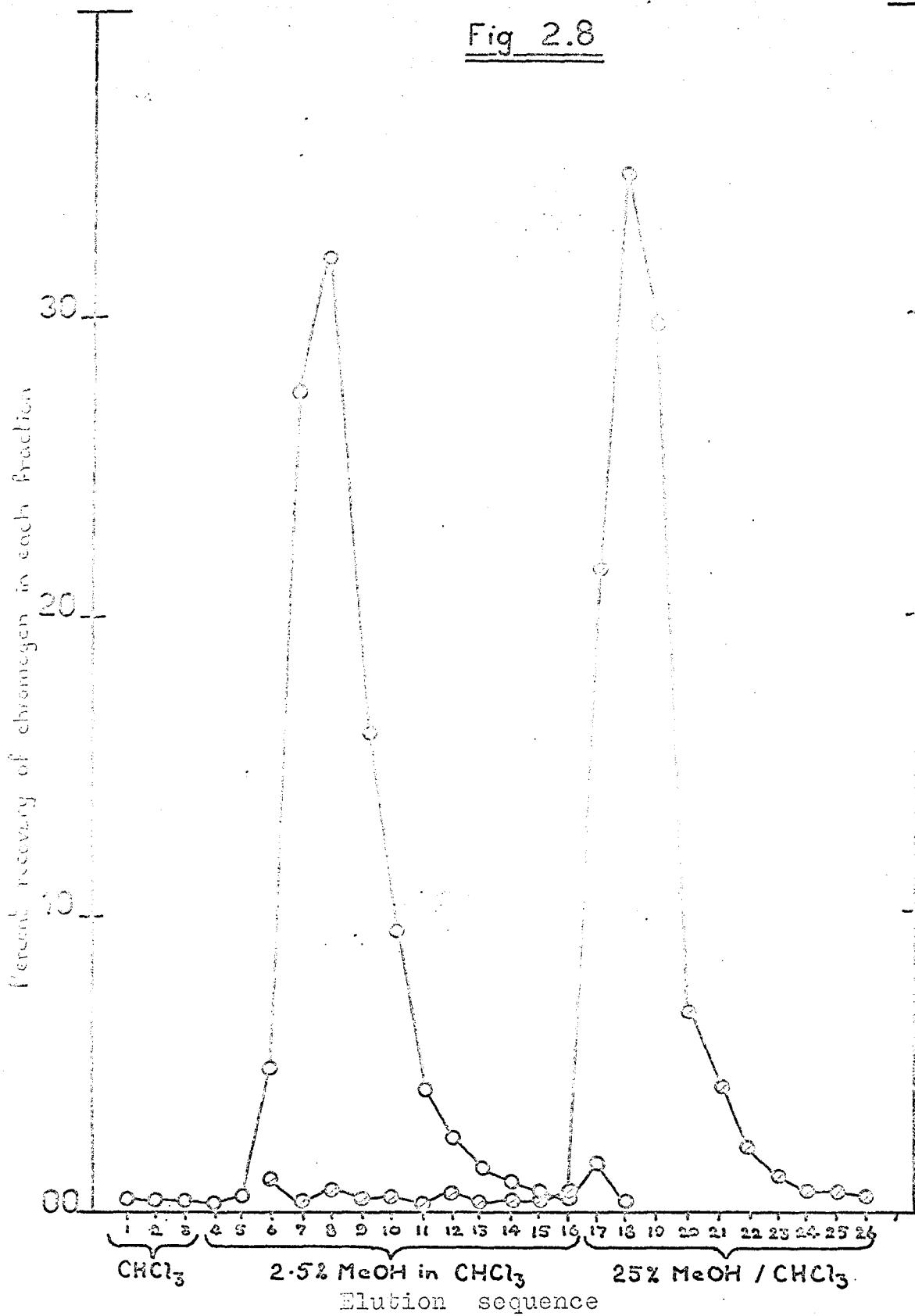

Separation of 11OH-E from cortisol on a florisil column with 2.5% MeOH / CHCl<sub>3</sub>

Fig 2.9

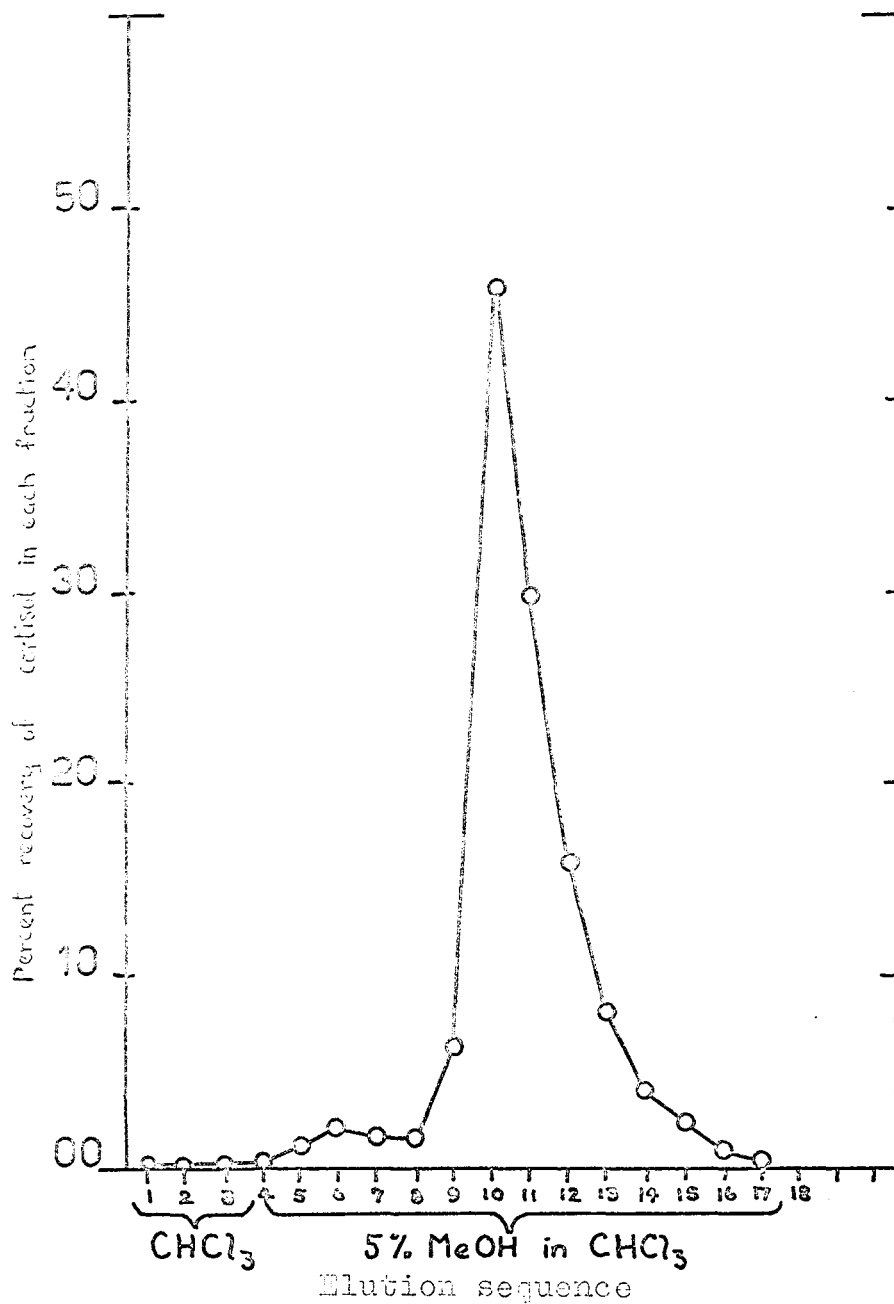

Elution of cortisol from a florisil column  
with 5% MeOH /  $\text{CHCl}_3$

Fig 2.10

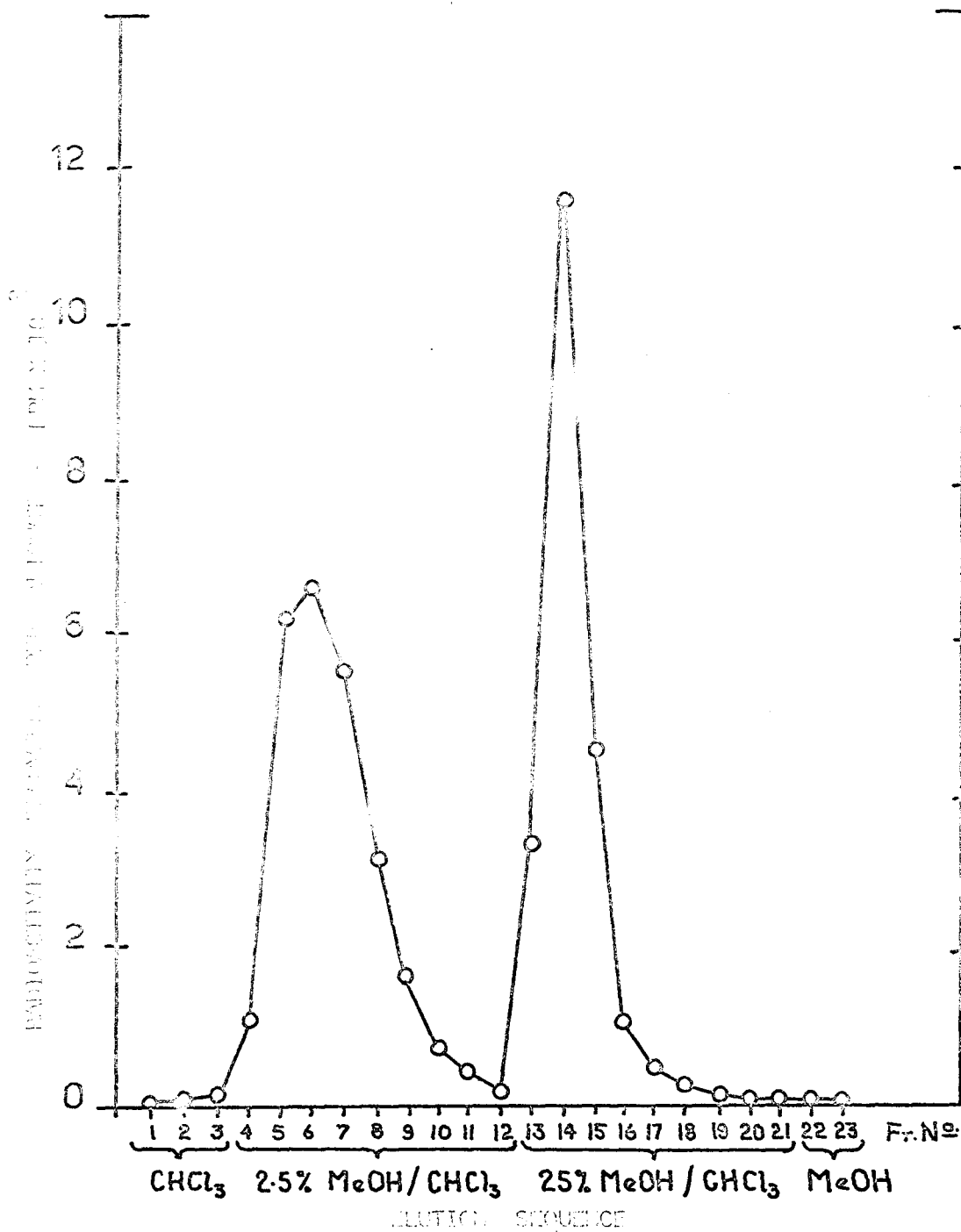

SEPARATION OF CORTISOL METABOLITES ON A FLORISIL COLUMN

fig. 2.9). Separation was such that no cross-contamination of c-19 and c-21 steroids was detectable by autoradiography of thin layer chromatograms of both fractions.

### 2.7.2 Thin Layer Chromatography (T.L.C.)

In this study extensive use was made of T.L.C. The advantage over paper chromatography of rapid plate development combined with the high resolution obtainable with T.L.C. made this an attractive procedure for steroid analysis.

Thin layers of thickness 0.25 mm. were prepared according to Stahl using the spreading equipment manufactured by Desaga Co., Heidelberg, Germany. The glass plates, 20 x 20 or 20 x 10 cm., were spread with a slurry of 30 Gm of silica gel-G, silica gel-GF254, or kieselgur; in 65 ml. of water: or 30 Gm of alumina in 50 ml. of water. For the 20 x 5 cm. plates, the water in the slurry was increased by 10%. All the thin layer absorbents contained binder, and were prepared by E. Merck, Darmstadt, Germany. After spreading, the plates were allowed 10-15 minutes to set, before activation at 110°C for 1-2 hours, and finally stored in an oven at 50°C.

Plates were developed in a 22 x 8 x 23 cm. glass tank, lined with No 3 MM Whatman filter paper, and fitted with a ground glass cover. Solvent was adjusted to a depth of  $\frac{1}{2}$  - 1 cm. after equilibration of the tank for up to 12 hours.

Continuous elution chromatograms were developed in a tank consisting of two 20 x 20 cm. glass plates separated by two thicknesses of glass, and epoxy-resin bonded in position to give internal dimensions of 13 cm. wide by 18 cm. deep and spaced 0.6 cm. This was sufficient to accommodate one 20 x 10 cm. or two 20 x 5 cm. chromatoplates. Plates were slid into the chamber, and then the solvent was run in, through a short piece of teflon tube, to a depth of 2 cm. As

the solvent reached the top of the tank it evaporated and allowed chromatography to continue.

Silica gel layers to be used for the preparation of pure compounds for mass spectrometry were washed in distilled methanol for 24 hours, using a large commercial continuous elution apparatus capable of holding two 20 x 20 cm. glass plates. They were used without reactivation, which was found to be unnecessary.

For partition systems the stationary phase was applied by pre-running in ethylene glycol (10% or 15% solution in acetone for 30 minutes; or 30% solution in methanol for 90 minutes). Plates were then dried under a stream of cold air leaving a uniform impregnation of glycol in the thin layer. (Spraying the plates with glycol in acetone, followed by weighing to a fixed quantity gave inferior results and reduced reproducibility. Dipping the plates in glycol acetone was also unsatisfactory as it often disturbed the layer, and this method is only applicable to cellulose layers.)

### 2.7.2.1 T.L.C. - Partition Systems

#### 2.7.2.1a Kg//glycol / CH<sub>2</sub>Cl<sub>2</sub>

This system was used for the separation of all the polar metabolites, including the more polar c-19 compounds. Originally used by Butruk and Vaedtkc(1968) as a single development system, it was modified during the course of this study to separate the very polar c-21 pentols and tetrols. Two to three hours constant elution was sufficient to completely separate the a- from the b-cortolones.

The kieselghur layered T.L.C. plates were developed in 10% ethylene glycol in acetone (30 minutes) or 15% glycol in acetone (1 hour). After placing the steroid (dissolved in chloroform) on the plate, a second development with dichloromethane - saturated with ethylene glycol, as the mobile phase gave Rf values for THE of approximately 0.35 and 0.2 respectively.

2.7.2.1b Kg//glycol 30% / benzene / Methylcyclohexane(1:1)

During the course of this study it was found necessary to develop a method for separation of the 17-ketosteroid metabolites of cortisol. The system arrived at allowed complete separation of the four principal 17-ketosteroids with a single development.

The kieselgur layer was impregnated with 30% ethylene glycol in methanol, and the mobile phase used was benzene/methylcyclohexane (1:1). This method was found to be less time consuming and more reproducible than the silica gel partition systems of Chang(1964).

2.7.2.2 T.L.C. - Adsorption systems

2.7.2.2a Alumina//toluene/ethyl acetate (3:1)

This system was used for the chromatography of 2,4-Dinitrophenylhydrazones of ketosteroids as described by Starnes,(1968).

2.7.2.2b Alumina//CCl<sub>4</sub>/ethyl acetate (1:1)

The products of chromic anhydride oxidation of ring-A reduced cortisol metabolites, 5a- and 5b-A-3,11,17-one, were chromatographed in this system as outlined by Lisboa(1968).

2.7.2.2c Silica gel-G//CHCl<sub>3</sub>/EtOH/H<sub>2</sub>O (176:26:2)

As used by Bailey (Wotiz and Clark,1968) for the determination of cortisone, cortisol, and polar cortisol metabolites, this system was found to have the characteristic of reversing the order of mobility of c-19-6 and c-19-8 relative to that in the partition system (see chapter 3).

2.7.2.2d Silica gel-G//ethyl acetate/cyclohexane (1:1)

Extensive use was made of this system, as a modification of that used by Cohn and Pancake(1964), running continuous elution for 4 to 5 hours. Good resolution and reproducibility was obtained when applied to the separation and identification of the

c-19-triols.

2.7.2.2e Silica gel-G//CHCl<sub>3</sub>/EtOH (94:6) as a first development, followed by drying at 40°C for 5 minutes and a second development in this system using CHCl<sub>3</sub>/CH<sub>2</sub>Cl<sub>2</sub>/EtOH (45:45:10) in the same direction as the first.

2.7.2.2f Silica gel-G//EtAc/CHCl<sub>3</sub>/H<sub>2</sub>O (90:10:1)

Both the above systems, 2.7.2.2e and f, as described by Kraion *et al* (1969), were effective for the separation of c-19-6 and c-19-8 from c-19-7 (see chapter 3).

### 2.7.2.3 Solvent Extraction of Thin Layer Material

A solution of 4-c<sup>14</sup>-cortisol in ethanol (20  $\mu$ L containing 10,000 d.p.m.) was spotted on to thin layers of kieselghur and silica gel (0.25 mm. thickness) over a total marked area of 4 cm<sup>2</sup>. This was scraped off and extracted twice with 5 ml. of the four listed solvents. Efficiency of extraction is shown in table 2-3. This confirms the inferior elution properties of CH<sub>2</sub>Cl<sub>2</sub> and EtAc. (Stahl, 1969) from silica gel.

Methanol was used for all extractions off kieselghur, after evaporation of the ethylene glycol (45°C, 24 hours). From silica gel, mixtures of ethyl acetate in methanol were used for c-21 corticosteroids to minimise the destruction of the more susceptible compounds that can occur when pure methanol is used. Methanol alone was used for elution of c-19 steroids from silica gel.

### 2.7.2.4 Transfer of Steroid Material without elution

For the transfer of a compound, that had been chromatographed in a kieselghur system, on to a silica gel plate, the layer containing the steroid was carefully scraped off and replaced at the origin of the silica gel chromatoplate. The kieselghur was dampened with a drop of water if necessary. The silica gel plate

was prepared for reception of the kieselgur by scribing a channel across the plate usually not greater than 5 mm. long and almost the width of the plate. Drying at a low temperature (40°C) for several hours preceded chromatography in the new solvent system.

Resolution was in no way impaired, and this method was found to be especially suited to transfer of small amounts of material without elution.

### 2.7.3 Detection of Corticosteroids on Thin Layer Plates

#### 2.7.3.1 Detection of Steroids with the -4-one- $\beta$ -one group

Although -4-one- $\beta$ -one steroids fluoresce in alkali, the sensitivity of this reaction is reduced on silica gel and alumina, but is unaffected with cellulose and kieselgur (Stahl, 1959). This method for the detection of the -4-one- $\beta$ -one group was replaced in this work, with the use of silica gel-GF254 (containing zinc silicate as a fluorescent indicator). Steroids with the -4-one- $\beta$ -one group appeared as dark spots on a bright yellow-green background under short wavelength ultraviolet illumination (sensitivity was observed to be better than 0.5  $\mu\text{g} / \text{cm}^2$ ).

#### 2.7.3.2 Spray Reagents

The use of spray reagents for the location and in some cases, the chemical group characterisation of steroids is well documented for paper chromatography (Bush, 1961). Many have been applied to thin layer work and corrosive spray reagents in particular have special application in this form of analysis, although they are restricted to the inorganic layers; silica gel, alumina and kieselgur.

##### 2.7.3.2.1 Non-specific spray reagents

###### 2.7.3.2.1(a) Acetic anhydride/Sulphuric acid

(Lieberman-Burchard reagent) (Tschesche, 1961)

Sensitivity: 0.05  $\mu\text{g}/\text{spot}$

low specificity

To 18 ml. absolute ethanol add 2 ml. of acetic anhydride and 2 ml. of conc.  $H_2SO_4$ , with cooling.

After spraying, heating at  $110^\circ C$  for 10 minutes gave optimum colour development. Longer heating (30 minutes) gave charring.

Viewing under long wavelength ultraviolet light, rather than natural light, resulted in greater sensitivity and usually different colours. The colours produced by isomers usually differ markedly, and can be used for tentative identification.

#### 2.7.3.2.1(b) Vanillin / Sulphuric acid (Mathews, 1963)

Sensitivity:  $0.05 \text{ ug/cm}^2$  low specificity

Reagent consists of 0.5% vanillin dissolved in absolute ethanol to which is added conc.  $H_2SO_4$ , to 40% (v/v). Treatment after spraying is the same as 2.7.3.2.1(a).

Unless the plate was completely free of solvent widely different colours for the same compound were obtained.

McAlloer and Kozlowski (1957) claim some specificity for this reaction with Pregnane--17-ol-20-one steroids giving orange spots.

#### 2.7.3.2.2 Specific spray reagents

##### 2.7.3.2.2(a) Blue Tetrazolium Reagent (Bush and Willoughby, 1957)

Sensitivity:  $0.5 \text{ ug/cm}^2$  for reducing steroids

Reagent prepared with 2% blue tetrazolium in 3 N ethanolic KOH was more sensitive than combinations of aqueous ethanol or methanol. If stored below  $0^\circ C$  the reagent was found to keep for several months.

Steroids with the  $\alpha$ -ketol side chain gave blue spots in the cold, but if warmed ( $40^\circ C$ ) the reagent was less specific.

##### 2.7.3.2.2(b) Zimmerman reagent (Lisboa, 1964)

Sensitivity:  $0.5 \text{ ug/cm}^2$  for 17-ketosteroids

The reagent was prepared with equal parts of 2% ethanolic m-dinitrobenzene (m-D.N.B.) and 2.5 N methanolic KOH, mixed immediately before use.

This reagent is considered to be specific for 17-ketosteroids but the actual colour is determined by other groups on the nucleus (Bush and Willoughby, 1957) e.g. 11b-OH, weak purple; 11-ketone, strong pink; and the 3 ketone confers considerable blueing to the 17-ketosteroid colour. Lisboa (1964) has reported -4-one-3-one steroids giving blue to violet colours.

#### 2.7.3.2.2(c) 2,4-dinitrophenylhydrazine reagent

Sensitivity:  $2 \text{ ug/cm}^2$  for ketones

Reagent consists of 0.1% 2,4-d.N.P.H. and 1% of 30% HCl in methanol. After spraying the plate is warmed to  $50^\circ\text{C}$  in a saturated atmosphere of methanol until the spots are completely developed.

Ketones gave yellow, and a,b-unsaturated ketones red-orange spots.

### 2.8 Methods of Corticosteroid Analysis

#### 2.8.1 Recording of Infra-Red (I.R.), Ultra Violet(U.V.) and Visible Spectra

Corticosteroids are rich in oxygen functions. These may be presented as primary, secondary, and tertiary ketone and alcohol groupings. All are capable of absorbing, with various degrees of intensity, infra red radiation.

I.R. spectra were recorded on a Perkin-Elmer, Infracord, split beam spectrophotometer using air as the reference media. Pure steroids and material for analysis was applied to sodium chloride discs as a solution in chloroform (special for spectroscopy, B.D.H.) and kept in solution during the scanning sequence. Spectra were aligned against the 6.24 micron peak of polystyrene.

Except for the absorption of the  $\alpha$ -ene- $\beta$ -ketone group, little information can be obtained from U.V. spectra of corticosteroids in organic solution. However, protonation of the oxygen functions with sulphuric acid gives characteristic absorption in both the U.V. and visible regions of the spectrum.

Spectra in the U.V. and visible regions were recorded automatically using a unicam, SF.800 recording spectrophotometer or manually using a Beckman D.U. spectrophotometer. The material was dissolved in methanol distilled off calcium chloride or in analar sulphuric acid and read against the pure solvent. Sulphuric acid spectra of a sample were recorded at 5 minutes and one hour from the time of dissolving. This usually gave two quite different yet characteristic spectra.

Mass spectra were determined on an A.E.I. MS902 high resolution mass spectrometer and the steroid structure resolved through fragmentation analysis.

## 2.8.2 Chemical Modifications to Corticosteroids

### 2.8.2.1 Borohydride Reduction

Borohydride reduction was first introduced by Chaikin(1949) and can be used with aqueous solutions, including urine directly (Menini,1965). The method followed was that of Appleby(1955), using an aqueous tertiary butanol solvent.

The material to be reduced was dissolved, or suspended, in 0.2 ml. aqueous tert-butanol (t-butanol/ $H_2O$ , 4:1). To this, 0.3 ml. of freshly prepared  $NaBH_4$  reagent (1 ml. of 10% w/v, aqueous  $NaBH_4$ , adjusted to 5.0 ml. with tert-butanol.) was added, and the reaction mixture left for 12 hours at room temperature. The mixture was cooled to  $0^\circ C$  and the reagent destroyed with 2 ml. of cold, aqueous acetic acid. (50% v/v). After addition of an equal volume of saturated sodium sulphate solution the reduced steroid was extracted with a polar organic solvent.

### 2.3.2.2 Bismuthate Oxidation

The method used for mild oxidation of the 17-ketogenic steroids was similar to that used by Appleby (1955).

The material to be oxidised dissolved in aqueous tert-butanol or methanol (0.5 ml.), was diluted with 2 ml. of 50% v/v aqueous acetic acid and 0.2 Gm sodium bismuthate was added. The suspension was shaken for 0.5 hour, the excess reagent removed by centrifugation and the supernatant cleared with a few drops of 5%  $\text{Na}_2\text{S}_2\text{O}_5$  aqueous solution. The oxidised steroid was extracted with dichloroethane, without further acidification of the aqueous layer.

The ability of sodium bismuthate to cleave the -17a,21-ol-20-one side chain as efficiently as it does the glycol side chain, was investigated. A non-radioactive urine sample ( $\frac{1}{2}$  of a 24 hour collection) was followed through the same steps as a "rhythm" sample (see chapter 3). Before sodium bismuthate oxidation, approximately 50,000 d.p.m. of 4-c<sup>14</sup>-cortisol, and 1 mgm of unlabelled cortisol was added to the urinary corticosteroids. Samples were taken from the oxidation mixture at appropriate time intervals. The reaction was stopped by centrifugation, and the addition of sod. metabisulphite to the separated supernatant (30 seconds). One extract with 5 ml. of ethylene dichloride was followed by concentration of the extracted material and chromatography in the system silica gel-GF254// $\text{CHCl}_3/\text{EtOH}/\text{H}_2\text{O}$ (174:26:2). The two -4-ene-3-ketone compounds; P-4-ene-11b,17a,21-ol-3,20-one (Rf, 0.345) and its oxidation product A-4-ene-11b-ol-3,17-one (Rf, 0.635), were easily visible under 254 mu. radiation and the absorbing areas were scraped off. The radioisotope present in each spot was measured and the amount of cortisol converted to the ketosteroid at each time interval was recorded as a percentage of the total originally present.

From results presented in fig. 2.10, it was concluded that (1) prior reduction was not necessary for complete oxidation

(2) the reaction was completed in 20 minutes.

#### 2.8.2.3 Acetylation

Acetylation of sterically unhindered hydroxyl groups was carried out according to the procedure of Bush(1961).

The material to be acetylated was dried in the tip of a centrifuge tube. Acetic anhydride (2 drops) and pyridine (1 drop), was added to the tube and the mixture left for 12 hours at room temperature, or 10 - 15 minutes at 60°C. This was found sufficient for completion of the reaction. The liquid was removed with a stream of dry nitrogen, at 45°C, leaving the acetylated product.

#### 2.8.2.4 Reaction with 2,4-dN.P.H.

Steroid ketones, especially conjugated 3-, and 17-ketosteroids, may react with 2,4-dN.P.H. to give orange or yellow crystalline derivatives, respectively. The method followed was that of Starnes et al(1966).

The steroid ketone in 0.1 ml. methanol, was mixed with 0.2 ml. of 2,4-dN.P.H. reagent. (0.2% 2,4-dN.P.H., 1.5% v/v conc. HCl, in MeOH - stored at 4°C). This was incubated at 60°C for 30 minutes. Pyruvic acid (2 drops) and 10% potassium acetate (1 ml.) was added, and left to react with the excess 2,4-dN.P.H. for 18 hours at room temperature. The steroid derivative was extracted with 5 ml. of chloroform, which was washed with 2 x 1 ml. of 2N sodium carbonate.

#### 2.8.2.5 Oxidation with Chromium Trioxide

Chromium trioxide can oxidise all secondary alcohol groups on the steroid nucleus to ketones.

The material to be oxidised was treated with

chromium trioxide 10% in pyridine (0.5 ml.) for 12 hours at room temperature. After the addition of 2 ml. water the steroid was extracted with 3 x 5 ml. benzene-ether (1:1). This was washed with 3 ml. of water and dried with anhydrous sodium sulphate.

#### 2.8.2.6 Girards Hydrazone Formation

Steroid ketones that are not sterically hindered may react with Girards Reagent-T ( $\text{NH}_2\text{-NH-CO-CH}_2\text{-N}^+(\text{CH}_3)_3$ ), this is especially so for the conjugated  $\beta$  ketone. The method followed was similar to that of Roberts *et al* (1968).

The dry steroid residue was heated for 20 minutes at  $90\text{-}100^\circ\text{C}$  with 100 mgm Girards Reagent-T (Lab. grade, from Koch-Light Lab.  $\text{L}^{\text{td}}$ .) in 0.5 ml. glacial acetic acid. The reaction mixture was cooled and 20 ml. of iced water added, before neutralising with 10% (w/v) NaOH solution (approx. 3.5 ml.). The nonketones were extracted with 2 x 20 ml.  $\text{CH}_2\text{Cl}_2$ , and the combined extractions were washed with 1 x 10 ml. water.

The steroid ketones were recovered from their Girard hydrazones by hydrolysis. The aqueous phase and washing from the previous step of the procedure were acidified with 1.0 ml. conc. HCl, and left at room temperature for 3 hours. The free ketone was extracted with 2 x 20 ml.  $\text{CH}_2\text{Cl}_2$ .

#### 2.8.2.7 Digitonin Precipitation

This method is that described by Butt *et al* (1943). For the specificity of the reaction see chapter 1, and for further comment see chapter 4.

The 4-c<sup>14</sup> labelled  $\beta$ -hydroxy steroid with about 0.5 mgm of carrier, 5b-A-3a,11b-ol-17-one, was dissolved in 0.75 ml. of digitonin solution (1% digitonin in warm 90% aqueous ethanol, stored at  $37^\circ\text{C}$ ) and boiled briefly. The stoppered tube was refrigerated overnight.

##### (a) precipitation of $\beta$ b-OH steroid

Peroxide free ether 2 x 2.5 ml., then 1 x 5 ml., was added with 15 minute intervals. After a further

FIG 2.11

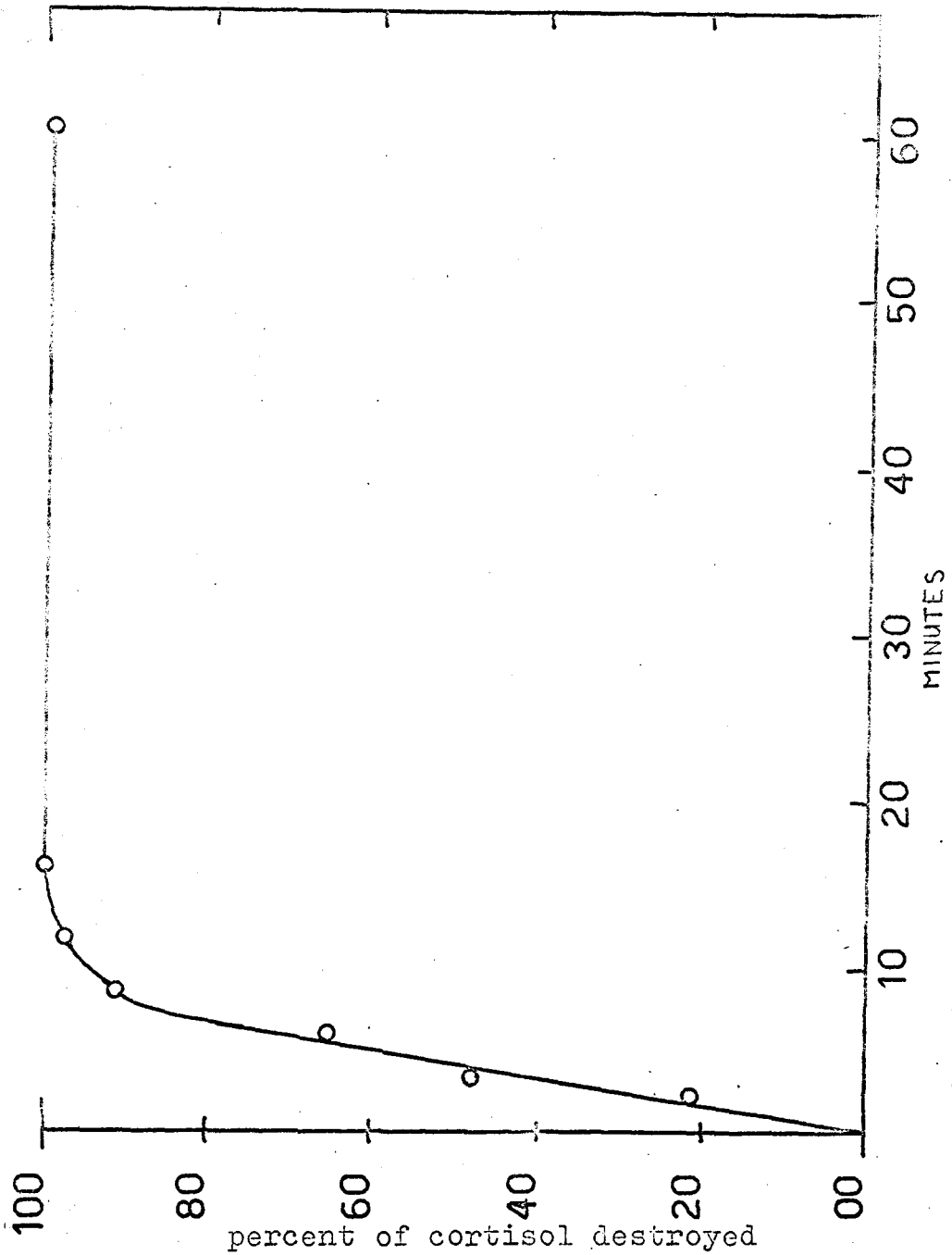

Rate of side chain cleavage of 4-c<sup>14</sup>-cortisol  
using sodium bismuthate

15 minutes the precipitate was collected by centrifugation, and washed with 3 x 5 ml. water, dried over anhydrous sodium sulphate and then counted. Radioactivity remaining in the ether is due to 3a-OH-4-c<sup>14</sup>-steroid (b) recovery of 3b-OH steroid

To hydrolyse the dried residue, 0.25 ml. of pyridine was added, and after 3 minutes at 55°C, cooled. Ether was added and the residue was washed with ether as in (a). The combined ether extracts were washed with 2 x 5 ml. of 2N H<sub>2</sub>SO<sub>4</sub>, followed by 2 x 5 ml. H<sub>2</sub>O, and then dried. The ether contains 3b-OH-4-c<sup>14</sup> steroid.

### 2.8.3 Colorimetric Methods

#### 2.8.3.1 Quantitative colorimetric determination of 17 ketosteroids

The determination of 17 ketosteroids was based on the Zimmerman reaction (Zimmerman, 1935). Investigation of conditions governing optimum performance of this reaction (see chapter 4) resulted in the following procedure.

Preparation of the absolute alcohol was found to be critical. The alcohol was distilled twice off m-D.H.B. (2 Gm/litre) and KOH pellets (10 Gm/litre), then redistilled (usually 2 to 3 times), rejecting the first and last 5%, until the reagent prepared as below, gave a negligible blank value (less than 0.05 O.D.).

Meta-dinitrobenzene (Specially purified for 17-KS determinations, B.D.H.) without further purification, was dissolved in absolute alcohol to give a 2% solution-reagent A. Tetramethylammonium hydroxide was diluted 1:1, with absolute alcohol to give approximately a 12% solution-reagent B. Equal volumes of reagent A, and reagent B, were mixed at 20°C immediately before use, and 0.5 ml. pipetted into a tube containing the 17 ketosteroid in 0.1 ml. of absolute alcohol. The tubes, along with a blank, and a tube containing 25 ug of DHEA, were incubated in the dark at 30°C, for 35 minutes. Immediately, 4 ml. of dichloromethane (15°C)

was added to each tube, and after 5 minutes at room temperature, 3.5 ml. of the coloured dichloromethane layer was pipetted into the centrifuge tubes containing about 250 mgm of anhydrous sodium sulphate. The tubes were shaken, centrifuged, and the optical density (O.D.) of the supernatant read at 520 m $\mu$  and 430 m $\mu$  against the blank no later than 60 minutes after mixing reagents A and B.

The colour correction equation of Talbot et al (1942) was applied:-

$$\frac{\text{Observed reading at 520 m}\mu - 0.6(\text{Observed reading at 430 m}\mu.)}{0.73}$$

0.73

= correct reading

The corrected reading obtained from this equation was applied to a standard curve of corrected reading against  $\mu$ g of DHEA. ((sensitivity:- approx. 0.02 O.D. units (corrected) per  $\mu$ g DHEA.))

### 2.8.3.2 Quantitative Colorimetric Determination of a-ketols

Steroids containing the a-ketol side chain give a pink colour in solution, with alkaline blue tetrazolium. ((3,3'-dianisole-bis 4,4'-(3,5-diphenyl) tetrazolium chloride))

The reagent was prepared with blue tetrazolium (B.T.Z.) solution (0.2% in absolute ethanol) 0.2 ml., mixed with 1.0 ml. of N ethanolic KOH, immediately before use. The absolute ethanol was distilled off  $\text{NaBH}_4$  (1 Gm/litre), and then distilled a further 2 times, rejecting the first and last 5%.

The a-ketol in 0.3 ml. absolute alcohol was diluted to 1.5 ml. with B.T.Z. reagent. After 15 minutes at room temperature, 2 ml. of methanol (distilled off  $\text{CaCl}_2$ ) was added to each tube, and the O.D. measured at 525 m $\mu$ . ((Sensitivity - approx. 0.5 O.D. unit per  $\mu$ g THF.))

## 2.9 Radiochemical Procedures

### 2.9.1 Radioactive Materials

The 4-c<sup>14</sup>-cortisol was obtained from the Radiochemical Centre, Amersham, England. The specific activity was 150 uCi/mgm (91% 4-c<sup>14</sup>-cortisol). Other radioactive derivatives of cortisol used in this work were prepared from this material using standard laboratory procedures. (see section 2.8.2 et seq.)

The purity of the radioactive cortisol was determined by T.L.C. using silica gel//CHCl<sub>3</sub>/EtOH/H<sub>2</sub>O (174:26:2), followed by autoradiography and scintillation counting of radioactive areas. Only one impurity was detected, amounting to less than 0.5% of that applied to the plate. This compound was less polar than 5α-A+3α-ol-11,17-one, and of unknown chemical composition.

### 2.9.2 Quantitative Determination of Radiochemicals

#### 2.9.2.1 Radioisotope scintillation counting

Scintillation solutions used were chosen to suit the nature of the solvent carrying the radiocompound, or the solubility in the scintillation cocktail, of the other solid material present.

The urine, bile, and other aqueous or very polar samples were counted in either Brays scintillation fluid-Naphthalene 50 Gm, PPO (2,5-diphenyl oxazole) 4 Gm, POPOP ((1,4-bis(2-(5 phenyloxazolyl))-benzene)) 200 mgm, ethylene glycol 20 ml., methanol 100 ml., dioxane (Nuclear enterprises (G.B.) L<sup>td</sup>; Edinburgh, Scotland.) to 1 litre; or triterphenol 7.5 Gm, POPOP 0.25 Gm, triton x-100 1.25 litre toluene 2.5 litre. The latter fluid can absorb up to 10% water. Material that is soluble in toluene was counted in a toluene scintillation fluid containing PPO 3 Gm and POPOP 100 mgm, per litre of toluene.

In all cases the radioisotope, in 10 ml. of scintillation fluid, was counted in a Packard Tricarb Liquid Scintillation Spectrometer, model 3375, using the c<sup>14</sup> channel. Each vial was counted for sufficient

time to five a percent standard deviation - generally less than 1.0%.

The counting efficiency of each sample was corrected, when necessary, from the AES (automatic external standardisation) readout by the spectrometer. The counting efficiency of each vial was computed from an A.E.S. vs percent efficiency curve for the quenching agent encountered. Curves were constructed using a fixed amount of 4-c<sup>14</sup>-cortisol, and A.E.S. values obtained from varying amounts of quenching agents found in the organic extracts of neutral urinary steroids (both the pink c-19, and the yellow c-21 fractions gave similar curves).

With heavily quenched vials, such as those encountered with crude urine and bile material, an internal standard of about 5,000 d.p.m. was used for efficiency correction.

Aliquots of less than 50 uL. and those used for internal standardisation, were measured with a Hamilton 50 uL. syringe (Hamilton Co., Whittier, California.)

#### 2.9.2.2 Scanning of Radiochromatograms

A Packard Radiochromatogram scanner, model 7200, was used for both thin layer and paper chromatogram scanning. A mixture of 1.3% isobutane in helium gas allowed ionisation in the open gieger tube at 1.1 KV. Gas flow was 110 cc/minute for thin layers and 150 cc/minute for paper. The slit width was adjusted to 2.5 mm. for the glass plates. The time constant was a function of the scanning speed, but for the most part the time constant was 30 seconds at a speed of 12 cm/hour, with a full scale deflection of 300 c.p.m. Radioactive areas were usually scraped off for scintillation counting. Measurement from the chart recorder of peak area by planimeter, weighing, or triangulation when possible, gave comparable results. (within 5% or better) Peak areas could be related to d.p.m. by spotting a known amount of 4-c<sup>14</sup>-cortisol on the thin layer plate as a marker.

### 2.9.2.3 Autoradiography of Radiochromatograms

The thin layer plates were kept under Xray film (Osray DM blue base -- Agfa gevaert -- Belgium) in a cool dark place for periods of from 4 days to 6 weeks, depending on the concentration of radioisotope present. The film was developed for 4 minutes at 26°C with a commercially made developer. (Phenidione Xray developer, made by Watson Victor, H.Z., for Ilford L<sup>td</sup>; London.) and after 30 seconds washed with 1.5% aqueous acetic acid, and fixed with sodium thiosulphate 200 Gm, potassium metabisulphite 12.5 Gm, per litre, for 10-20 minutes. The film was washed in running water for one hour, then dried.

For quantitation of the spots the film was placed over the plate and the areas marked for scraping off and counting. The film was also scanned with a densitometer (Made by Photovolt Corporation). The output from the densitometer was fed into a chart recorder (Varicord) fitted with an integrator which gave a direct measure of the peak area.

--- /- / ---

## Chapter 3

EXPERIMENTAL AND RESULTS

The radioactive urinary cortisol metabolites obtained from the I.V. administration of 4-c<sup>14</sup>-cortisol to the sheep, were dissolved in ethanol-free chloroform and separated into c-19 and c-21 fractions by column chromatography using florisil. The elution of c-19 steroids resulted in recovery of 54.8% of the total recoverable radioactivity from the column. At this stage the c-21 steroids remained on the column.

The c-19 steroids were chromatographed in the system Kg//glycol (15%)/CH<sub>2</sub>Cl<sub>2</sub>, which allowed separation into three distinct groups. The position of these groups was determined by radiochromatogram scanning. After evaporation of the glycol, zones were scraped off the plate as follows and steroid was recovered by elution:-

(1) From the position of PHE to  $R_{E/F}$  0.33, which contains the five c-19,-3,11,17-triols detected. (Nomenclature  $R_{E/F}$  refers to the position of the component between the mobility of cortisol (F), and that of cortisone (E), and is calculated from Rf data as follows:-

$$R_{E/F} \text{ of } X = \frac{(Rf, X) - (Rf, \text{cortisol})}{(Rf, \text{cortisone}) - (Rf, \text{cortisol})}$$

This method compensates for any variation in Rf values that may occur due to dissimilar chromatographic conditions.)

(2) From  $R_{E/F}$  0.33 to the position of cortisone, which contains the four c-19,-3,17-diol-11-one steroids detected.

(3) From the position of cortisone to the solvent front, which contains the five ketosteroids detected. Each of the above groups was subjected to chemical and chromatographic analysis to determine the structure

TABLE 3-1

C-19 metabolites of cortisol isolated from the urine of a whole sheep

( values expressed as a percent of the total radioactive metabolites)

code	identity	%
c-19-14	5a-A-3a-ol-11, 17-dione ( 11KA)	1.05
c-19-13	5b-A-3a-ol-11, 17-dione ( 11KE)	9.1
c-19-12	- - - - -	2.55
c-19-11	5a-A-3a, 11b-diol-17-one (11OEA)	1.5
c-19-10	5b-A-3a, 11b-diol-17-one (11OHE)	3.25
c-19-9	5a-A-3a, 17b-diol-11-one	1.25
c-19-8	5b-A-3a, 17a-diol-11-one	14.1
c-19-7	5c-A-3b, 17a-diol-11-one	7.35
c-19-6	5b-A-3a, 17b-diol-11-one	9.75
c-19-5	5c-A-3a, 14b, 17a-triol	0.3
c-19-4	5c-A-3a, 14b, 17b-triol	0.45
c-19-3	5c-A-3b, 14b, 17a-triol	1.45
c-19-2	5b-A-3a, 14b, 17a-triol	2.2
c-19-1	5b-A-3a, 14b, 17b-triol	0.45

Fig 3.1

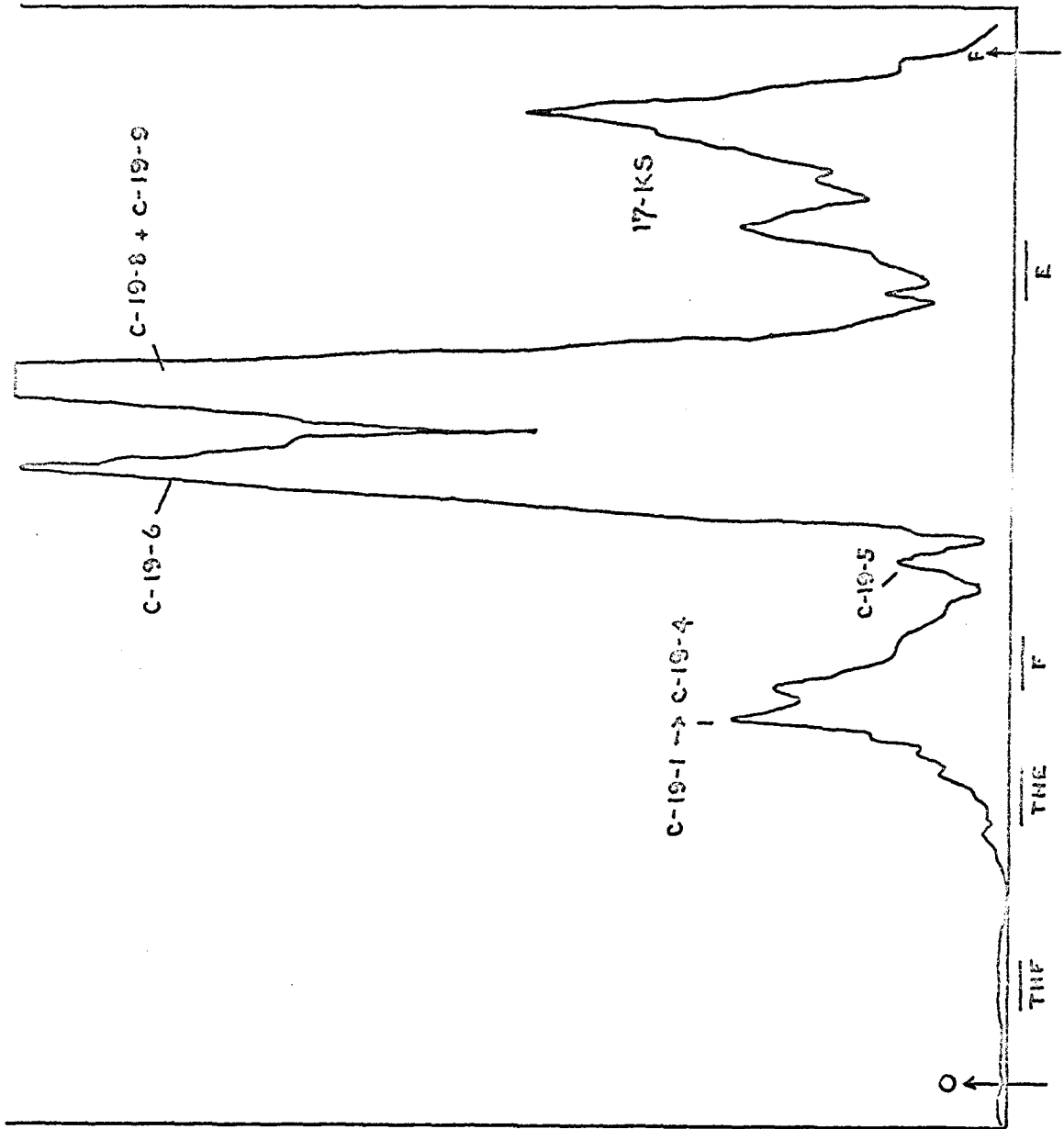

c-19 fraction

Scan of total c-19 fraction from a florisil column following development in T.L.C. system

Eg/ glycol/ CH<sub>2</sub>Cl<sub>2</sub>

Fig 3.1a

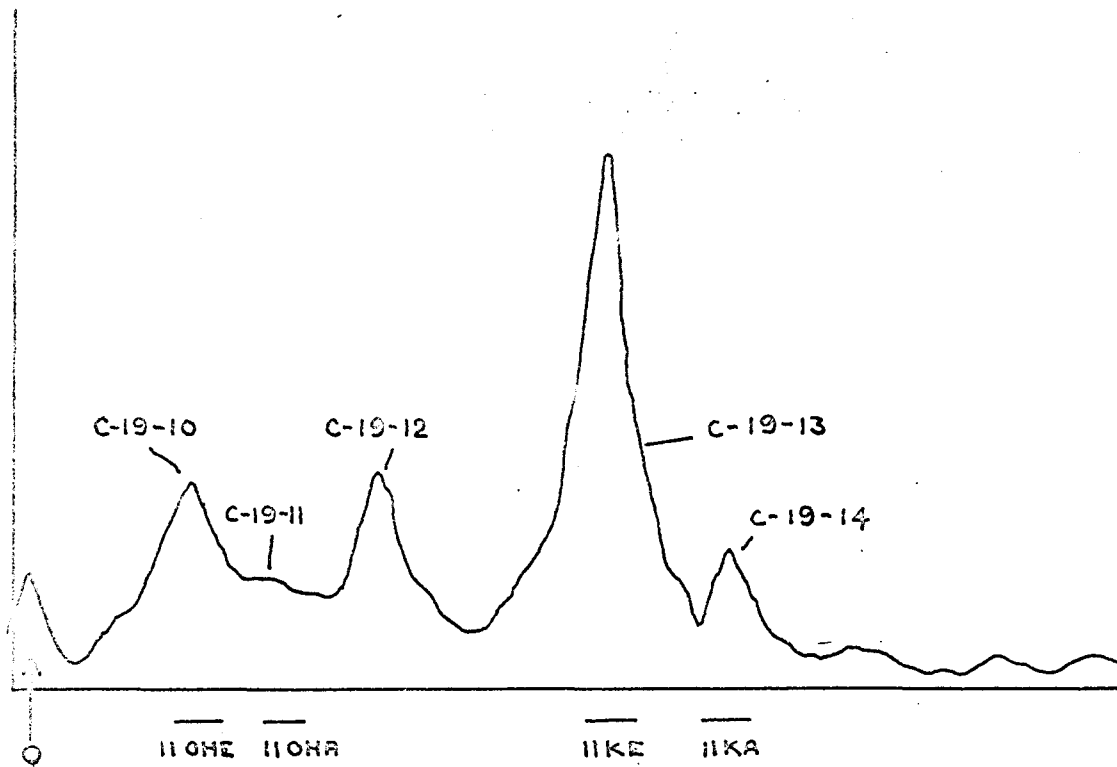

17-KS fraction

Rem of 17-hydroxysteroid fraction, following A.E.C.  
in the system: // glycol/benzene: cyclohexane

---

Fig 3.2

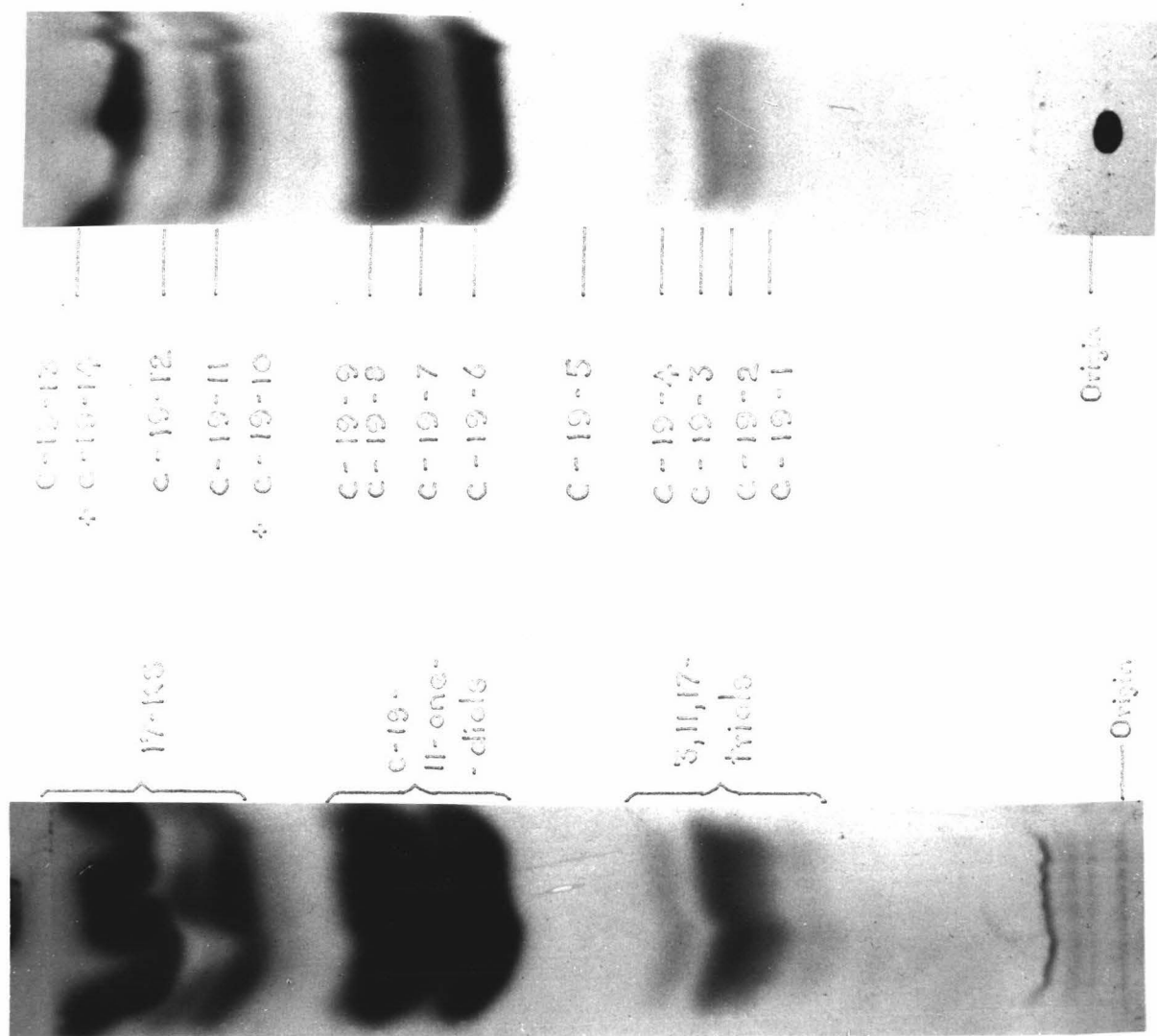

Autoradiographs of thin layer chromatograms of c-19 fraction developed in the system Kg/ glycol/ CH<sub>2</sub>Cl<sub>2</sub>

of the corticosteroid metabolites present. The components of each group that were isolated, are listed in table, 3-1, along with the code numbers and quantity of each expressed as a percentage of the total radioactive metabolites obtained from the 4- $c^{14}$ -cortisol. The code number may appear as  $c^{14}$ -19-, which indicates the steroid referred to contains isotopic carbon and should be compared with c-19- nomenclature reserved for unlabelled steroid in this chapter.

### 3.1 The -3,17-ol-11-one group

The two distinct peaks showing on the radiochromatogram trace (fig. 3.1), after scanning of the K<sub>g</sub>//glycol (15%)/CH<sub>2</sub>Cl<sub>2</sub> plate (system, 2.7.2.1a), were scraped off separately. Each was chromatographed in the system SG.GF254//CHCl<sub>3</sub>/EtOH(94:6)/CHCl<sub>3</sub>/CH<sub>2</sub>Cl<sub>2</sub>/EtOH (45:45:10) (system, 2.7.2.2c). In this system  $c^{14}$ -19-6 and  $c^{14}$ -19-8 both have an R<sub>f</sub> of 0.39, while  $c^{14}$ -19-7 was easily separable with an R<sub>f</sub> of 0.53. The width at the base of each peak was not in excess of 0.1 R<sub>f</sub> units. Unlabelled authentic DHE, F, and E showed R<sub>f</sub> values of 0.18, 0.38, and 0.60 respectively in this system (spray, 2.7.3.2.2a). Any cross contamination remaining between  $c^{14}$ -19-6 and  $c^{14}$ -19-8 was best removed by rechromatography in the K<sub>g</sub>//glycol (15%)/CH<sub>2</sub>Cl<sub>2</sub> system.

#### 3.1.1 Characterisation of $c^{14}$ -19-6 and $c^{14}$ -19-8

##### 3.1.1.1 Infra-red absorption characteristics

The I.R. spectra of c-19-6 and c-19-8 were essentially identical except for the fingerprint region. Both consisted of a broad -OH stretching peak between 2.8 and 3.3 microns, a small broad peak from 4.4 to 5 microns, and a large single peak at 6.0 microns. The absence of absorption at 6.2 and 5.8 microns eliminates the -4-ene-3-one, and the -17-one functions respectively (Klyne, 1957 and own observations- the

I.R. spectra of several pure c-21 and c-19 authentic compounds were recorded. Those chosen contained the common I.R. absorbing groups likely to be encountered in this work.) A strong, broad absorption from 9 to 10 microns, in the hydroxyl stretching region with a sharp peak at 9.3 microns, was present in the spectrum of c-19-8 but absent in that of c-19-6.

#### 3.1.1.2 Ultra-violet absorption characteristics

Both c-19-6 and c-19-8 showed no absorption in the 241 mu. region, and only slight absorption in the 280-290 mu. region, which may be indicative of the 11-ketone function (Klyne, 1957).

The spectra in  $H_2SO_4$  were inconclusive, with both c-19-6 and c-19-8 showing broad maxima at 305 mu. and a slight inflexion at 400 mu., consistent with a 3-OH-11-ketone. (Zaffaroni, 1950)

#### 3.1.1.3 Mass Spectroscopy

Both c-19-6 and c-19-8 had an empirical formulae of  $C_{19}H_{30}O_3$ . Fragmentation indicated an 11 ketone, and hydrogen replacement showed the presence of two hydroxyl groups. It may be concluded therefore, that c-19-6 and c-19-8 are stereoisomers about the hydroxyl groups on carbons 3 or 17.

#### 3.1.1.4 Oxidation

Oxidation of  $c^{14}$ -19-6 and  $c^{14}$ -19-8 with the  $CrO_3$ /pyridine reagent, and subsequent co-chromatography with 5a-A-3,11,17-one and 5b-A-3,11,17-one in the  $Al/CCl_4/EtAc$  (1:1) system (system, 2.7.2.2b) (spray, 2.7.3.2.2b), indicated a 5b-Androstane nucleus for both  $c^{14}$ -19-6 and  $c^{14}$ -19-8. (Standards used in this system were 5a-A-3a,11b-ol-17-one (Rf 0.2), 5b-A-3a,11b-ol-17-one (Rf 0.15), and their complete oxidation products; 5a-A-3,11,17-one (Rf 0.52) and 5b-A-3,11,17-one (Rf 0.52) and 5b-A-3,11,17-one (Rf 0.38)).

### 3.1.1.5 Digitonin Precipitation

Digitonin has the property of forming aqueous insoluble addition products with 3-alcohol groups trans to the 19-methyl group i.e. 5b-A-3b-ol-configurations.

Both  $c^{14}$ -19-6 and  $c^{14}$ -19-8 were treated with the digitonin reagent (see, 2.8.2.7). As a control, a mixture of THE (3a-OH, 0.25 mgm) and DHEA (3b-OH, 0.25 mgm) was separately subjected to identical treatment, and the mixture was also added to each of the radioactive steroid solutions.

THE recovered by hydrolysis of the precipitate and that remaining in the supernatant was assayed by the blue tetrazolium reaction (see, 2.8.3.2); and similarly DHEA was assayed by the Zimmerman reaction (see, 2.8.3.1). The 3a and 3b fractions were counted (without recovery of the 3a-alcohol as free steroid), and the amount of radioisotope present determined. Results indicated that the  $c^{14}$ -19-6 and  $c^{14}$ -19-8 steroids are both 3a-alcohols. (see table, 3-2)

### 3.1.1.6 Girard Hydrazone Formation

The 17-ketosteroid 11OHE (5b-A-3a, 11b-ol-17-one),  $c^{14}$ -19-6 and  $c^{14}$ -19-8, were treated with Girard's reagent T (see, 2.8.2.6). Recovery of 11OHE in the 'ketonic' fraction was 97% (by the Zimmerman reaction). Recovery of  $c^{14}$ -19-6 in the 'non-ketonic' fraction was 96%, and recovery of  $c^{14}$ -19-8 in the 'non-ketonic' fraction was 98% (by scintillation counting). This confirms the absence of a ketone function on carbons 3 or 17.

### 3.1.1.7 Borohydride Reduction

To determine the steric configuration of the 17-hydroxyl group of c-19-6 and c-19-8, several 17-hydroxyl compounds were prepared by reduction of the 17-ketone with  $\text{NaBH}_4$  to give the 17b-alcohol exclusively (Gaylord, 1956). Although known to be sterically hindered, the 11-ketone was found to be

TABLE 3-2

Digitonin precipitation of metabolites  $c^{14}$ -19-6 and  
 $c^{14}$ -19-8

Component measured	Source	Quant. Recover. % of total	% of Config. total
E (by S.A.E.)	ppt.	2	3.5
	super.	200	97.5
E (by HPLC.)	ppt.	200	83
	super.	40	17
$c^{14}$ -19-6	ppt.	11	1.5
	super.	985	98.5
$c^{14}$ -19-8	ppt.	11	1
	super.	1000	99

TABLE 3-3

Chromatographic behavior of  $R_{FE}$  reduced  $c^{14}$ -19-6 and  
 $c^{14}$ -19-8 in two systems

Component	$R_{FE}$ C/glycol/CH <sub>2</sub> Cl <sub>2</sub>	$R_{FE}$ 3G/EtAc/cyclohex
E	1.00 (Rf 0.70)	1.00 (Rf 0.60)
$c^{14}$ -19-6	0.35	-
$c^{14}$ -19-8 *	0.75	1.00
F	0.50	0.81
$c^{14}$ -19-6-11b-ol	0.42	0.73
$c^{14}$ -19-8-11b-ol †	0.38	0.67
5b-A-3a, 17b-ol-11-one*	0.75	1.02
5b-A-3a, 11b, 17b-ol †	0.38	0.67
THE	0.34	0.54

Note similarity between components indicated by \* ,  
and also similarity between components indicated by † .

reducible by  $\text{NaBH}_4$ , although not as rapidly as the 17-ketone. To make use of this observation, 5b-A-3a-ol-11,17-one (11KE) was reduced at room temperature ( $20^\circ\text{C}$ ) for 10 minutes and the reaction stopped before completion, by the addition of acetic acid. This was found to give a mixture of three compounds - (1) a small amount of unaltered 11KE,

(2) 5b-A-3a,17b-ol-11-one

(3) 5b-A-3a,11b,17b-ol

The 11-alcohol and the 11-ketone were formed in about equal quantities under these conditions.

Chromatography of  $c^{14}$ -19-6 and  $c^{14}$ -19-8, and their 11b-OH derivatives in several solvent systems, gave values reported in table 3-3. The mobilities of  $c^{14}$ -19-6 and  $\text{NaBH}_4$  reduced  $c^{14}$ -19-6 in both systems is consistent with those obtained from 5b-A-3a,17b-ol-11-one and 5b-A-3a,11b,17b-ol respectively.

### 3.1.1.8 Acetylation

Both  $c^{14}$ -19-6 and  $c^{14}$ -19-8 were acetylated (see, 2.8.2.3) and chromatographed in the system SG//EtAc/cyclohexane (1:1) (system, 2.7.2.2d). They were co-chromatographed with 5b-A-3a,11b-ol-17-one-acetate, and 5b-A-3a,11b,17b-ol-diacetate. Both the  $c^{14}$ -19-6 (Rf 0.66) and the  $c^{14}$ -19-8 (Rf 0.63) were positioned in the 5b-A-3a,11b,17b-ol-diacetate spot; with 5b-A-3a,11b-ol-17-one-acetate having a Rf of 0.57.

The position of both  $c^{14}$ -19-6/ $c$ -19-6 and  $c^{14}$ -19-8/ $c$ -19-8 acetates, after spraying with the acetic anhydride/sulphuric acid spray (spray, 2.7.3.2.1a), was seen as a pink area when viewed under U.V. (365 mu.) illumination. The '5b'-acetates show pink, and '5a'-acetates show orange fluorescence with this spray (own observations).

### 3.1.2 Characterisation of $c^{14}$ -19-9

This compound was not separable from  $c$ -19-8 in

TABLE 3-4

Chromatographic values of NaBH<sub>4</sub> reduced c<sup>14</sup>-19-8 and c<sup>14</sup>-19-9 in two systems

Component	R <sub>F</sub>	R <sub>F</sub>
	Hg/glycol/CH <sub>2</sub> Cl <sub>2</sub>	SG/EtAc/cyclohex
E	1.00 (Rf 0.7)	1.00 (Rf 0.47)
c <sup>14</sup> -19-9	≈ 0.87	-
c <sup>14</sup> -19-8	0.57	-
c <sup>14</sup> -19-9-11b-OH	0.52	0.97
F	0.50	0.81
c <sup>14</sup> -19-8-11b-OH	0.45	0.73
5a-A-3a, 17b-11-one	0.88	-
5a-A-3a, 11b, 17b-ol	0.53	0.97

TABLE 3-5

ΔR<sub>F</sub> values for 11-ketone reduction of c-19-6 ↔ c-19-9

c-19-9 -- c-19-9-11b-OH (c-19-4)	+ 0.53	(5αA-)
c-19-8 -- c-19-8-11b-OH (c-19-2)	+ 0.64	(5βA-)
c-19-7 -- c-19-7-reduced	+ 0.50	(5αA-)
c-19-6 -- c-19-6-11b-OH (c-19-1)	+ 0.44	(5βA-)

TABLE 3-6

Chromatographic values of c-19-7 and its NaBH<sub>4</sub> - reduction product in two systems

Component	R <sub>F</sub>	R <sub>F</sub> /R <sub>F</sub>
	Hg/glycol/CH <sub>2</sub> Cl <sub>2</sub>	SG/EtAc/cyclohex
c <sup>14</sup> -19-7	0.81	-
c <sup>14</sup> -19-7-11b-OH	0.46	1.13
5a-A-3b, 17b-ol-11-one	-	1.37
5a-A-3b, 11b, 17b-ol	-	0.7
5a-A-3a, 11b, 17a-ol	0.69	-
5a-A-3a, 11b, 17b-ol	0.53	0.97
E	1.00 (Rf 0.75)	1.00 (Rf 0.62)
11E		0.0 (Rf 0.30)

the Kg//glycol/CH<sub>2</sub>Cl<sub>2</sub> partition system. After reduction with NaBH<sub>4</sub>, the derivative of this steroid was partially separated from c<sup>14</sup>-19-8-11b-OH in the Kg//glycol (15%)/CH<sub>2</sub>Cl<sub>2</sub> system (system, 2.7.2.1a), and completely separated in the SG//EtAc/cyclohexane (1:1, 5.5 hours) system (system, 2.7.2.2d). A mixture of 5a-A-3a,17b-ol-11-one and 5a-A-3a,11b,17b-ol was prepared from 5a-A-3a-ol-11,17-one using a 10 minute NaBH<sub>4</sub> reduction (see, 3.1.1.7). The mixture was co-chromatographed with c<sup>14</sup>-19-9 and c<sup>14</sup>-19-9-11b-OH in the solvent systems given in table,3-4. The chromatographic properties of c-19-9 and its NaBH<sub>4</sub> reduction product, as reported in table,3-4, are consistent with the compounds 5a-A-3a,17b-ol-11-one, and 5a-A-3a,11b,17b-ol respectively.

### 3.1.3 Characterisation of c<sup>14</sup>-19-7

This compound has a similar chromatographic mobility to c-19-8 in the Kieselghur system (system, 2.7.2.1a) but was separable from both c-19-6 and c-19-8 in the silica gel system 2.7.2.2e, or 2.7.2.2f.

Determination of the configuration of the c-5 hydrogen was determined by chromic anhydride oxidation (see,2.8.2.5) of c<sup>14</sup>-19-7, and chromatography in the Al//CCl<sub>4</sub>/EtAc (1:1) system (system,2.7.2.2b; spray 2.7.3.2.2b). The oxidised c<sup>14</sup>-19-7 was found to have an identical mobility to that of 5a-A-3,11,17-one (see,3.1.1.4) in this system.

Δ R<sub>Mr</sub> values (where R<sub>M</sub>=log<sub>10</sub> (1/Rf-1), see chapter 4) for the conversion of c-19-7 to NaBH<sub>4</sub> reduced -c-19-7, obtained from chromatography in the Kg//glycol/CH<sub>2</sub>Cl<sub>2</sub> system, were compared with values for the reduction of c-19-6, c-19-8 and c-19-9 in the same chromatographic system. The value obtained for c-19-7 agrees sufficiently well with other -11-one to -11b-ol conversions, to justify assigning a ketone group to carbon 11. (see, table,3-5).

Reduction of  $c^{14}$ -19-7 with  $\text{NaBH}_4$  gave a compound having similar chromatographic properties to  $c^{14}$ -19-3 in the SG//EtAc/cyclohexane (1:1), 5 hours) system (system, 2.7.2.2d).

The identity of c-19-7 is probably restricted to one of four possible stereoisomers, namely; 5a-A-3a,17b-ol-11-one, 5a-A-3b,17b-ol-11-one, 5a-A-3a,17a-ol-11-one, 5a-A-3b,17a-ol-11-one. Of these only the former two may be prepared chemically:-

(1) 5a-A-3a,17b-ol-11-one was synthesised as a mixture of the 11-ketone and 11b-hydroxyl compounds by borohydride reduction of the appropriate 17-ketosteroid (5a-A-3a-ol-11,17-one) for 10 minutes at  $20^\circ\text{C}$  (see,3.1.1.7)

(2) 5a-A-3b,17b-ol-11-one was prepared from 5a-A-3a,11b-ol-17-one, by consecutive oxidation and reduction. About 50 ug of the 17-ketosteroid was oxidised with chromic anhydride (see,2.8.2.5). The resulting trione was isolated from a benzene/hexane (1:1) extract of the reaction mixture by chromatography in the  $\text{Al}/\text{CCl}_4/\text{EtAc}$  (1:1) system (system,2.7.2.2b). Reduction of the trione for 10 minutes at  $20^\circ\text{C}$  using  $\text{NaBH}_4$ , gave a mixture of products consisting mainly of 5a-A-3b,17b-ol-11-one and 5a-A-3b,11b,17b-ol (Gaylord,1956).

Chromatography of  $c^{14}$ -19-7 and its reduction product, against the laboratory prepared compounds, resulted in  $R_E$  and  $R_E/\text{THE}$  values reported in table,3-6. ( $R_E$  of a compound X =  $R_f$  of X/ $R_f$  of cortisone). From reference to table,3-6 the structure of c-19-7 is suggested as 5a-A-3b-17a-ol-11-one; the other 5a-A-11-one alternatives being eliminated on grounds of dissimilar chromatographic mobilities.

### 3.2 The -3,11,17-ol group

As a preliminary analysis, steroids  $c^{14}$ -19-1 through  $c^{14}$ -19-5 were chromatographed separately in the system SG//EtAc/cyclohexane (1:1) against reference standards E,F and THE (spray,2.7.3.2.2a). The

$R_E$  values obtained before, and after reduction of the steroid with  $\text{NaBH}_4$ , were identical. It was concluded that these four steroids, by their chromatographic properties and absence of reducible groups, were 19-carbon, triol isomers.

### 3.2.1 Characterisation of $c^{14}$ -19-2 and $c^{14}$ -19-3

The region containing labelled steroids  $c^{14}$ -19-2 and  $c^{14}$ -19-3 was located on a  $\text{Kg//glycol}(10\%)/\text{CH}_2\text{Cl}_2$  plate, by scanning. The steroid was eluted and applied to, or transferred directly on to, a silica gel plate and run in the  $\text{EtAc/cyclohexane}$  (1:1) system (system, 2.7.2.2d) for 4 hours against unlabelled 5b-A-3a,11b,17b-ol and 5a-A-3a,11b,17b-ol. These two compounds were prepared by  $\text{NaBH}_4$  reduction of 5b-A-3a,11b-ol-17-one, and 5a-A-3a,11b-ol-17-one respectively for one hour at room temperature (see,3.1.1.7). The position of unlabelled markers was detected visually after plate development with spray 2.7.3.2.1a (see table,3-7).

Steroid  $c^{14}$ -19-2 was also chromatographed in the  $\text{Kg//glycol}(10\%)/\text{CHCl}_3$  system (Butruk and Vaedtke,1968; same conditions as system 2.7.2.1a) against 5b-A-3a,11b,17b-ol, 5a-A-3a,11b,17b-ol, E(Rf0.7), F, THE and THF (see table,3-8). Reference to table,3-7 and 3-8, it was concluded that c-19-2 and c-19-3 differ from both 5b-A-3a,11b,17b-ol and 5a-A-3a,11b,17b-ol.

After oxidation of  $c^{14}$ -19-2 and  $c^{14}$ -19-3 with chromic anhydride in pyridine (see,2.8.2.5), the triones formed were chromatographed in the system  $\text{Al//CCl}_4/\text{EtAc}$  (1:1) against unlabelled authentic 5a-A-3a,11b-ol-17-one, 5b-A-3a,11b-ol-17-one, and also the complete oxidation products of these two compounds, 5a-A-3,11,17-one and 5b-A-3,11,17-one respectively (spray,2.7.3.2.2b). From results set out in table,3-9, it can be seen  $c^{14}$ -19-2 has a 5b-Androstane nucleus, and  $c^{14}$ -19-3 a 5a-Androstane nucleus.

The four steroids  $c^{14}$ -19-2,  $c^{14}$ -19-3,  $c^{14}$ -19-7-11b-OH and  $c^{14}$ -19-8-11b-OH (the latter two compounds were

TABLE 3-7

Chromatographic mobilities of c-19-2 and c-19-3 in the system 3G//EtAc/cyclohexane

Component	Rf
5a-A-5a, 11b, 17b-ol	0.19
c <sup>14</sup> -19-2	0.22
5a-A-5a, 11b, 17b-ol	0.29
c <sup>14</sup> -19-3	0.34

TABLE 3-8

Chromatographic mobilities of c-19-2 in the system 2G//glycol/CHCl<sub>3</sub>

Component	Rf
THF	0.10
THF	0.27
5b-A-5a, 11b, 17b-ol	0.35
F	0.46
c <sup>14</sup> -19-2	0.47
5a-A-5a, 11b, 17b-ol	0.49

TABLE 3-9

Chromatographic mobilities of c-19-2 and c-19-3 after chromic anhydride oxidation, in the system Al//OOL/Bac (1:1)

Component	Rf	
	plate-1	plate-2
5b-A-5a, 11b-ol-17-one	0.12	0.16
5a-A-5a, 11b-ol-17-one	0.19	0.22
5b-A-3, 11, 17-one	0.37	0.39
5a-A-3, 11, 17-one	0.51	0.54
c <sup>14</sup> -19-2-oxidised	0.36	-
c <sup>14</sup> -19-3-oxidised	-	0.52

synthesised from  $c^{14}$ -19-7 and  $c^{14}$ -19-8 by  $\text{NaBH}_4$  (see, 2.8.2.1) reduction), were chromatographed separately in the system SG-GF254//EtAc/cyclohexane (1:1, 5 hours; system 2.7.2.2d) against authentic unlabelled E, F, THE; and 5a-A-3a,11b,17b-ol and 5b-A-3a,11b,17b-ol (E and F, were detected by viewing under 254 mu. illumination, others detected with spray, 2.7.3.2.1a). From the results set out in table, 3-10 it was concluded that  $c^{14}$ -19-2 (plate, 1) is the 11b-OH derivative of  $c^{14}$ -19-8 (5b-A-3a,17a-ol-11-one) and  $c^{14}$ -19-3 is the 11b-OH derivative of  $c^{14}$ -19-7 (5a-A-3b,17a-ol-11-one).

### 3.2.2 Characterisation of $c^{14}$ -19-1 and $c^{14}$ -19-4

The triols  $c^{14}$ -19-1 and  $c^{14}$ -19-4 were each co-chromatographed in the system Rg//glycol(10%)/ $\text{CH}_2\text{Cl}_2$  (2.7.2.1a), and also in SG-GF254//EtAc/cyclohexane (1:1, 5 hours; system 2.7.2.2d), with the laboratory synthesised compounds 5b-A-3a,11b,17b-ol, and 5a-A-3a,11b,17b-ol respectively (see, 3.1.1.7). Authentic E, F, and THE were also co-chromatographed to one side of the radioactive compounds and detection methods were the same as in section 3.2.1. The results reported in table, 3-11, suggests identification of  $c^{14}$ -19-4 with 5a-A-3a,11b,17b-ol, and  $c^{14}$ -19-1 with 5b-A-3a,11b,17b-ol.

### 3.2.3 Characterisation of $c^{14}$ -19-5

A radioactive compound chromatographing midway between c-19-4 and c-19-6 in the Rg//glycol/ $\text{CH}_2\text{Cl}_2$  was unchanged upon treatment with  $\text{NaBH}_4$ . The high Rf value of this triol would indicate a 5a-a-3a,11b,17a-ol configuration, this being the only triol less polar than c-19-4. The small amount present did not allow confirmation of this structure.

Further evidence for these structures was obtained by comparison of  $\Delta R_{\text{Mr}}$  values of pairs of compounds differing only in the configuration of the hydroxyl groups on carbon -17, in the system Rg//glycol(15%)/ $\text{CH}_2\text{Cl}_2$ .

TABLE 3-10

Comparison of the chromatographic mobilities of reduced c-19-7 and c-19-8, with the two triols c-19-2 and c-19-3

Component	R <sub>F</sub> // Ethic/cyclohexane			
	plate 1	plate 2	plate 3	plate 4
E	0.50	0.55	0.45	0.54
5b-A-5a, 11b, 17b-ol	0.55	0.55	0.60	0.67
F	0.79	0.78	0.77	0.81
5a-A-5a, 11b, 17b-ol	0.98	0.97	0.98	0.97
c <sup>14</sup> -19-2	0.71	-	-	-
c <sup>14</sup> -19-3	-	1.10	-	-
c <sup>14</sup> -19-7-reduced	-	-	1.08	-
c <sup>14</sup> -19-8-reduced	-	-	-	0.73

TABLE 3-11

The chromatographic mobilities of c<sup>14</sup>-19-1 & c<sup>14</sup>-19-4 in two systems

Components	R <sub>F</sub> /HE	R <sub>F</sub>
	SG/glycol/CH <sub>2</sub> Cl <sub>2</sub>	SG/EtAc/cyclohex
E	-	1.00
F	1.00	0.59
5a-A-5a, 11b, 17b-ol	1.05	0.58
5b-A-5a, 11b, 17b-ol	0.15	0.38
HEE	0.00	0.33
c <sup>14</sup> -19-4	1.02	0.58
c <sup>14</sup> -19-1	0.15	0.39

These are reported in table,3-12.

### 3.3 The 17-Ketosteroid group

The  $c^{14}$ -17-KS fraction was chromatographed in the system Kg//glycol(30%)/benzene/Me.cyclohex (1:1,2.7.2.1b). The five distinct peaks on the trace after scanning the radiochromatogram were numbered in sequential order from the origin (table,3-13). The plate was sprayed, after evaporation of the glycol, with a Zimmerman spray (spray,2.7.3.2.2b) to show the position of four unlabelled 17-KS compounds co-chromatographed with the radioactive material. These were authentic 5a-A-3a,11b-ol-17-one (11-OH-A), 5b-A-3a,11b-ol-17-one (11-OH-B), 5a-A-3a-ol-11,17-one(11-K-A), and 5b-A-3a-ol-11,17-one. The latter was prepared from THE in high yield with  $\text{NaBiO}_3$  oxidation, followed by isolation of the KS using preparative T.L.C. on methanol washed silica gel. The solvent used was  $\text{CHCl}_3/\text{EtOH}/\text{H}_2\text{O}$  (174:26:2, 2.7.2.2c).

Peak-1 was found to consist of two steroids  $c^{14}$ -19-10 and  $c^{14}$ -19-11, while peaks-2 to 4 were given  $c^{14}$ -19-12, -13,14. Peak-5 was found to have similar chromatographic properties to that of a trace impurity found in the original 4- $c^{14}$ -cortisol that was used.

#### 3.3.1 Chromic anhydride oxidation

Oxidation of each radioactive peak with chromic anhydride (see,2.3.2.5) and subsequent chromatography of the resultant triones (see,3.1.1.4) with 5a-A-3,11,17-one and 5b-A-3,11,17-one (prepared from 5a-A-3a-ol-11,17-one and 5b-A-3a-ol-11,17-one respectively, using the same reagent) on alumina, in the solvent system EtAc/cyclohexane (1:1,2.7.2.2d), resulted in assigning the nuclear configurations listed in table,3-14. The 5a-A- trione in peaks 1 and 3 was present as a minor component while the 5b-A- configuration assigned to peak 2 ( $c^{14}$ -19-12) was only tentative as the trione appeared to chromatograph at a somewhat slower rate than

TABLE 3-12

$R_M$  and  $\Delta R_M$  values for the  $17\beta \rightarrow 17\alpha$  epimerisation  
in two trials and one trial, for the  
mg// glycol(15%)/CH<sub>2</sub>Cl<sub>2</sub> system

Component	Rf	$R_M$	$\Delta R_M$
<u>MF</u>			
c-19-1=5b-A-3a, 11b, 17b-ol	0.17	0.43	} -0.15
c-19-2=5b-A-3a, 11b, 17a-ol	0.34	-0.02	
c-19-4=5a-A-3a, 11b, 17b-ol	0.425	-0.19	} -0.16
c-19-5=5a-A-3a, 11b, 17a-ol	0.515	-0.35	
c-19-6=5b-A-3a, 17b-ol-11=o	0.61	0.43	} -0.15
c-19-8=5b-A-3a, 17a-ol-11=o	0.70	0.28	
B	0.81		

TABLE 3-13

17-ketosteroid mobilities from scanning of a  
mg//glycol (30%)/benzene/methylcyclohexane (1:1)  
radiochromatogram of the crude metabolites

Component	Rf
peak-1 (c <sup>14</sup> -19-10, c <sup>14</sup> -19-11)	0.15
peak-2 (c <sup>14</sup> -19-12)	0.30
peak-3 (c <sup>14</sup> -19-13)	0.43
peak-4 (c <sup>14</sup> -19-14)	0.57
peak-5	0.83
5b-A-3a, 11b-ol-17-one	0.15
5a-A-3a, 11b-ol-17-one	0.22
5b-A-3a-ol-11, 17-one	0.49
5a-A-3a-ol-11, 17-one	0.58

TABLE 3-14

Chromic anhydride oxidation of the 17-ketosteroids

<u>Component</u>	<u>config<sup>H</sup>. at c-5-H</u>
peak 1 - c <sup>14</sup> -19-10,11	5b-A (& 5a-A)
peak 2 - c <sup>14</sup> -19-12	5b-A region
peak 3 - c <sup>14</sup> -19-13	5b-A (& 5a-A)
peak 4 - c <sup>14</sup> -19-14	5a-A

TABLE 3-15, 16

Borohydride reduction of 17-ketosteroids and chromatography in system SG/ EtAc - cyclohexane(1:1)

<u>Component</u>	<u>R<sub>m</sub></u>			
E	1.00	1.00	1.00	1.00
F	0.82	0.82	0.77	0.78
THE	0.54	0.52	0.53	0.53
5a-A-5a, 11b, 17b-ol	0.98	0.96	0.96	0.97
5b-A-5a, 11b, 17b-ol	0.70	0.68	0.68	0.69
c <sup>14</sup> -19-10	0.70			
c <sup>14</sup> -19-12		0.68		
c <sup>14</sup> -19-13			0.71	
c <sup>14</sup> -19-14				0.99

TABLE 3-17

Chromatography of the 17-ketosteroid-2,4-dNPH formation products

<u>Component</u>		1	2	3	4	5	9NEA	11ONE	11KE
c <sup>14</sup> -19-10	R <sub>test.</sub> <sup>⊙</sup>	0.60	0.40	0.13	0.68	0.10	0.90	0.80	0.71
	- % <sup>⊙</sup>	60	20	10	5	5			
c <sup>14</sup> -19-12	R <sub>test.</sub>	0.35	0.13	0.58	0.12		0.90	0.75	0.66
	- %	60	15	10	10				
c <sup>14</sup> -19-13	R <sub>test.</sub>	0.56	0.40	0.12	0.75		0.87	0.70	0.56
	- %	70	10	10	5				

(<sup>⊙</sup> see text)

the 5b-A-trione.

### 3.3.2 Borohydride Reduction

Radioactive peaks 1 to 4 were separately reduced with  $\text{NaBH}_4$  overnight (see, 2.8.2.1) and the reaction products run on SG-GF254 in the solvent system EtAc/cyclohexane (1:1, 5 hours; 2.7.2.2d). Each was co-chromatographed with authentic E, F, DHE and laboratory prepared 5a-A-3a, 11b, 17b-ol and 5b-A-3a, 11b-17b-ol (Prepared by  $\text{NaBH}_4$  reduction of 11-OH-A and 11-OH-E, respectively; 2.8.2.1). The reduced radiocompound was positioned after development of the plate, by scanning, and tentative or firm identification of each product was made after viewing under U.V. (254 nm.) illumination, and spraying with  $\text{Ac}_2\text{O}/\text{H}_2\text{SO}_4$  (spray, 2.7.3.2.1a) to locate the unlabelled reference compounds (table, 3-16).

### 3.3.3 Formation of 2,4-dN.P.H. derivatives

Each of the peaks 1 to 3 was separately converted to its 2,4-dinitrophenylhydrazone (see, 2.8.2.4). Subsequent chromatography of a chloroform extract of the reaction mixture on alumina in the system toluene/EtAc (3:1, 2.7.2.2a), followed by scanning of each plate, showed several products. The  $R_{\text{Test.}}$  ( $R_{\text{Test.}}$  value being the mobility of each component relative to that of testosterone derivative, where  $R_{\text{Test.}}$  of testosterone = 1.0). Values of the major products formed are reported in table, 3-17 with the relative amounts expressed as an approximate percentage of the total radioactivity on the plate. The unlabelled 2,4-dN.P.H. derivatives of testosterone, DHEA, 11-OH-E and 11-K-E, were co-chromatographed with the radioactive material, were present in sufficient concentration to be easily detectable in daylight as yellow or orange bands.

### 3.4 Quantitation of the $c^{14}$ -19-metabolites

c-19-fraction from column  
 ( c-19-1 → c-19-14 )  
 Et//glycol/ CH<sub>2</sub>Cl<sub>2</sub> (scan)

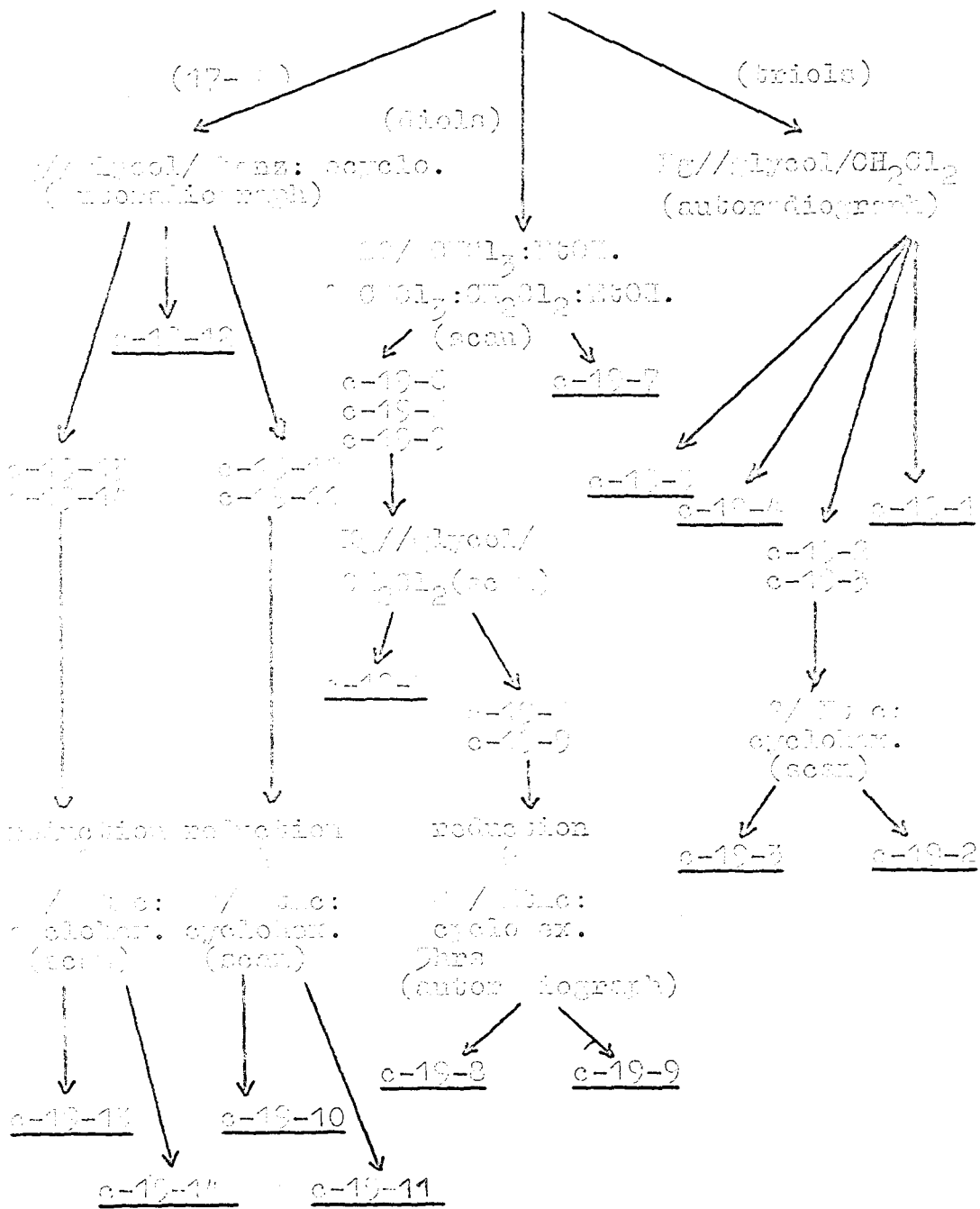

Fig. 3.3

The separation of the c-19-fraction into its individual components

TABLE 3-18

quantitation of series-A, B c-1 metabolites

code	Identity	%	code	Identity	%
A-11	- - - -	2.0	B-12	- - - -	0.45
A-10	THF	11.15	B-11	cortisone	0.35
A-9	- cortolone	0.7	B-10	- - - -	0.65
A-8	- cortolone	5.0	B-3/9	- - - -	1.2
A-7	- - - -	0.55	B-7	- - - -	0.35
A-6	- - - -	0.65	B-6	- - - -	0.85
A-5	- - - -	0.4	B-5	cortisol	2.75
A-4	- - - -	0.45	B-4	THE	3.0
A-3	- - - -	2.25	B-3	- - - -	0.35
A-2	$\alpha + \beta$ - cortol	6.9	B-2	- - - -	0.5
A-1	- - - -	1.4	B-1	allo-THF	1.6
remaining on origin		0.3			

Fig. 3.3

Quantitation of the c-24 metabolites

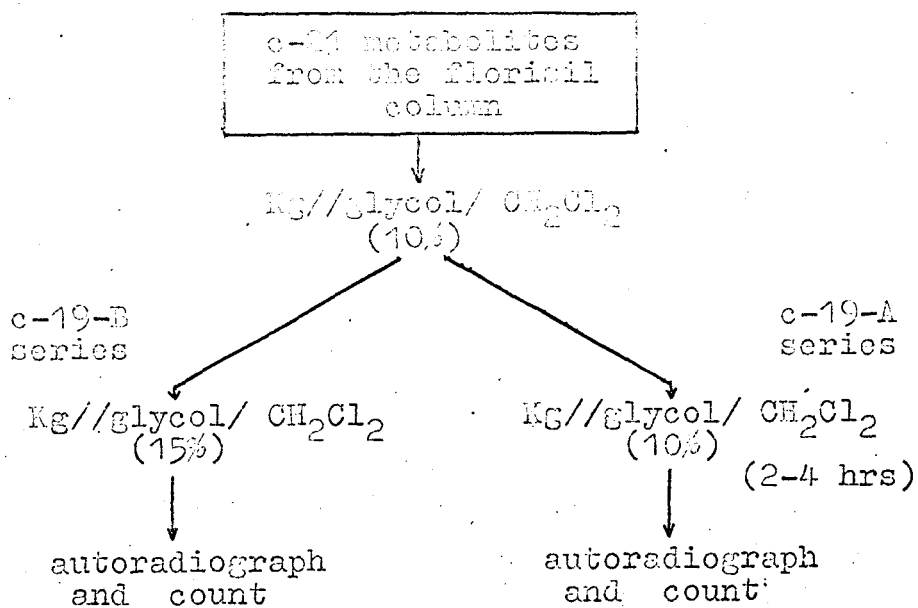

To measure the relative quantities of each c-19 metabolite present in the free steroid extract, the total c<sup>14</sup>-19-fraction was subdivided by chromatography into the three fractions already mentioned. Further subdivision was in accordance with fig.3.2. At each step, the ratios between the steroids, or groups of steroids, was determined by scintillation counting. The positions of each labelled steroid, or group of steroids, was accurately known before counting, by either scanning with the radiation detector (for large separation between components), or by autoradiography.

It must be appreciated that there are some limitations with this system. Metabolites that are obviously present but not detected (minor metabolites), will be quantitated in conjunction with some whose structures are known. With this in mind, the amount of each c<sup>14</sup>-19 metabolite, expressed as a percentage of the total free steroid extracted, is presented in table,3-1.

---

The radioactive c-21 cortisol metabolites were eluted with 25% methanol in chloroform from the florisil column resulting in a recovery of 45.2% of the total recoverable radioactivity (as free steroid) from the column. Further elution using methanol resulted in collection of radioactive material amounting to 2.5% of that applied to the column, while radioactivity recovered in the c-21 and c-19 elutions accounted for 97% of that applied to the column.

The 100% methanol fraction was chromatographed on Ag//glycol(10%), using a constant elution system with  $\text{CH}_2\text{Cl}_2$ , for three hours. The plate was scanned, and a single peak-Rf 0.02 (Rf cortisol = 0.10), was eluted. Elution with methanol was unnecessary, therefore, succeeding only in removing steroid conjugates. Only 0.3% of the radioactivity eluted with 25% methanol in chloroform remained on the origin when chromatographed in the above system.

Initially the total complement of c-21's was chromatographed on Ag//glycol(10%)/ $\text{CH}_2\text{Cl}_2$ , single development, and the region of more polar compounds from the origin to c-21-A-11 (series-A) was scraped off for re-chromatography in the same system for 3 hours. These less polar compounds remaining on the plate (Rf greater than c-21-A-11) were designated members of series-B (see table, 3-18).

### 3.5 Characterisation of the B-series

Comparison of positions of unlabelled corticosteroids, chromatographed with the labelled metabolites, allowed direct identification of E (c-21-B-11), F (c-21-B-5), THE (c-21-B-4), and allo THE (c-21-B-1). Oxidation of c-21-B-4 and c-21-B-1 with chromic anhydride, confirmed the 5b-P- structure of c-21-B-4 and the 5a-P- structure of c-21-B-1.

Both c-21-B-2 and -B-3, as well as -B-4 and -B-5 were strongly positive to a blue tetrazolium spray (spray 2.7.2.2a, room temperature). Both c-21-B-5



Fig 3.4a

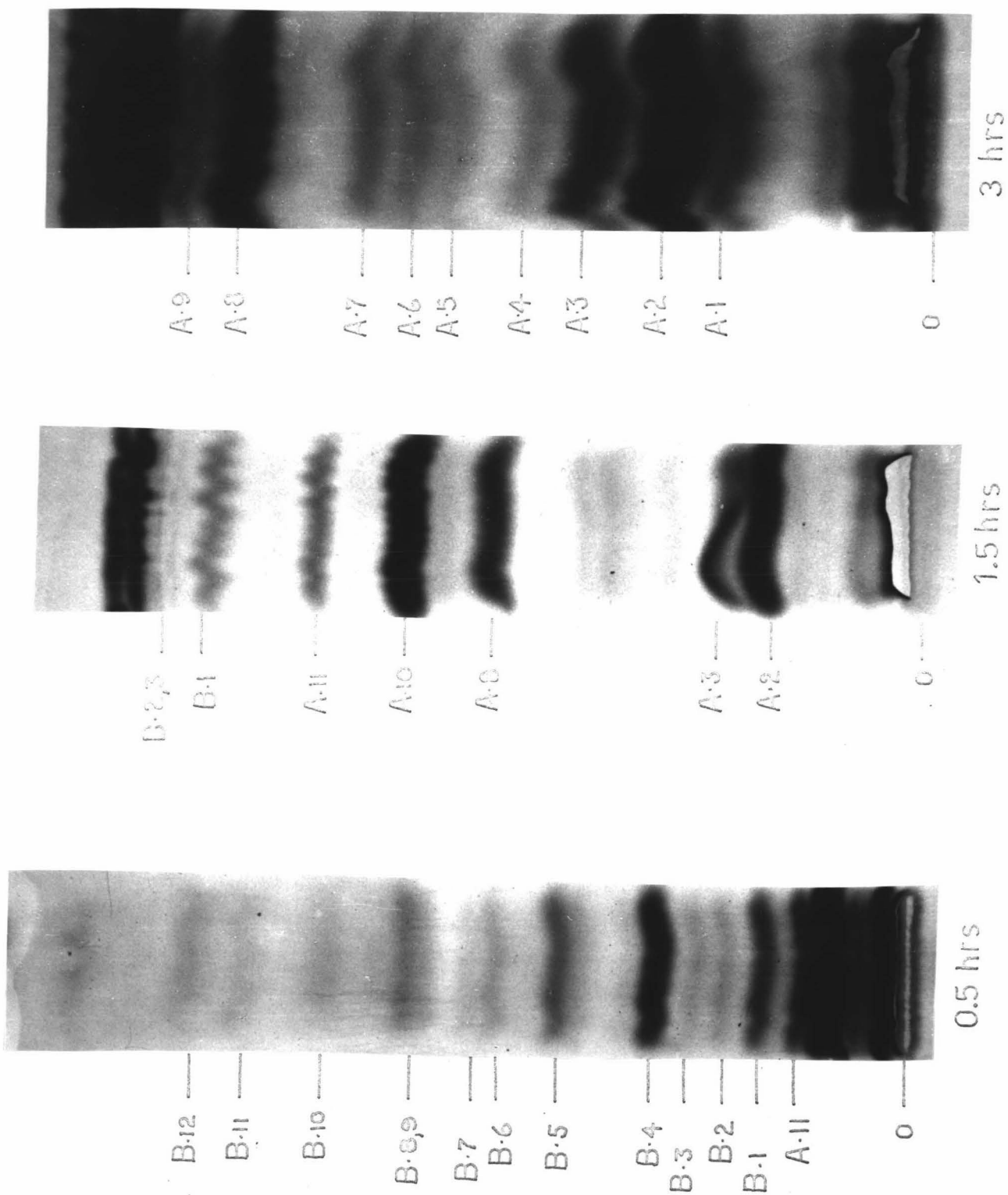

Autoradiographs of thin layer chromatograms of c-21 fraction developed in the system Kg/. glycol/ CH<sub>2</sub>Cl<sub>2</sub>

and -B-11 were visible as orange bands on a yellow background after spraying with 2,4-dN.F.H. solution (spray, 2.7.3.2.2c), indicating a conjugated  $\beta$ -ketone ( $\alpha$ -one- $\beta$ -one) (Starnes et al, 1963). Both -B-12 and -B-8/9 were visible as a darker yellow band, and this may be due to the presence of a  $\beta$ -ketone compound.

In summary, only 4 of the c-21-B series can be firmly identified - these being c-21-B-11, -B-5, -B-4, and -B-1. Of the other steroids in this series the presence of 5b-P-11b, 17a, 21-ol- $\beta$ , 20-one and its 5b-P-17a, 21-ol- $\beta$ , 11, 20-one and the 5a-P- isomers must be assumed.

It is of interest to note that the  $AR_{MIR}$  values between -B-2 and -B-6; -B-3 and -B-7, are 0.55 and 0.525 respectively. This compares well with values from table, 3-12, where the average value of  $AR_{MIR}$  for the 11-ketone reduction is  $\pm$  0.53. If this can be applied to -B-2 and -B-3, then they are 5b and 5a isomers of an 11b-ol- $\beta$ -one compound. (The  $\beta$ -ketone is less polar than  $\beta$ a-OH grouping). As the  $\beta$ -one group is less polar than the  $\alpha$ -one- $\beta$ -one (F, in this case) there may be further reduction in the molecule. This may be effected by reduction of the 20-ketone, to the a- or b-hydroxyl. The possibility of hydroxylation of some other position in the steroid nucleus (e.g. carbon 2 or 6), which would provide the necessary increase in polarity, must not be overlooked, especially in view of the strong B.F.Z. reaction obtained relative to the amount of steroid present. This would indicate the  $\alpha$ -ketol group is still intact.

A further possibility for the structure of -B-2 and -B-3 is the a- and b-allocortolones, which would be expected in this region.

Without further investigation it must be only conjecture that -B-8/9 and -B-10 are 5b-P-11b, 17a, 21-ol- $\beta$ , 20-one and the 5a-P- isomer respectively. This agrees with the proposition that c-21-B-12 is 5b-P-17a, 21-ol- $\beta$ , 11, 20-one, being the only cortisol

metabolite of importance that is less polar than cortisone. The  $AR_{Mr}$  (-B-8/9  $\rightarrow$  -B-12) is -0.58, also in good agreement with the  $AR_{Mr}$  value for the 11b-OH to 11-one reaction, for this chromatographic system.

### 3.6 Characterisation of the A-series

To enable resolution of the less active bands present, it was found necessary to autoradiograph each plate before spraying the edges only with a corrosive spray to locate the unlabelled reference compounds. The reference compounds were authentic b-cortol, a-cortol, b-cortolone, a-cortolone and THF. The a- and b-cortolones were easily separable in this system, and were found to correspond with the radioactive bands -A-8 and -A-9 respectively. The 11b-OH steroids a- and b-cortol are only partially separable in this system and migrated with band c-21-A-2. Band c-21-A-10 corresponded exactly with that of authentic THF.

#### 3.6.1 Acetylation of the Cortol Group

During this investigation it was observed that 24 hour acetylation at room temperature of b-cortol and a-cortol produced rather different patterns after chromatography in the system SG//CHCl<sub>3</sub>/EtOH/H<sub>2</sub>O (174:26:2; spray 2.7.3.2.1a). This difference should allow the ratio of a-cortol to b-cortol to be measured after acetylation. (see table, 3-19)

However, when applied to the radioactive cortol group (A-2), inconclusive results were obtained, probably due to other isomers being present in the region.

#### 3.6.2 Chromic Anhydride Oxidation

After oxidation and subsequent chromatography of the c<sup>14</sup>-19-triones in the system Al//CCl<sub>4</sub>/EtAc (1:1; system, 2.7.2.2b; spray, 2.7.3.2.2b). Some bands were found to be mixtures of 5a-P- and 5b-P- steroids. All the steroids were 5b-P-, except for -A-11 and -A-3; -A-11 showed a 5a-P- nucleus while the -A-3

band consisted of 60% 5a-P- and 40% 5b-P-. The c-21-A-1 oxidation product chromatographed as neither 5a- or 5b-trione, with an Rf of 0.3. This would suggest an additional oxygen function present in the nucleus, effecting the increase in polarities.

### 3.6.3 Oxidation with Sodium Bismuthate

#### 3.6.3.1 The c-21 group as a whole

A complete c<sup>14</sup>-21 aliquot was oxidised with sodium bismuthate (2.8.2.2), and after florisil column separation the 17-ketosteroid was chromatographed in the kieselghur partition system for 17-ketosteroid separations (2.7.2.1b). After autoradiography the areas corresponding to 5b-A-3a, 11b-ol-17-one, 5a-A-3a, 11b-ol-17-one, c-19-12, and 5b(35a)-A-3a-ol-11, 17-one, were scraped off and counted. An active area between the 5b--11b-ol-17KS and the origin was not clearly defined and was included with the area between the 11-ketone-17KS and the front (total of about 5%). The quality of each group, expressed as a percentage of the radioisotope applied to the plate, is given in table, 3-20.

#### 3.6.3.2 Following a preliminary separation

The fine major bands A1, A2, A3, A8 and A10, were subjected to mild oxidation, involving the cleavage of the c-20,21 side chain with sodium bismuthate. In each case a mixture of 17-ketosteroids were produced, but only the significant compounds are reported. Separation of these was achieved in the Eg//glycol (30%) /benzene/methylcyclohexane.

The major side chain cleavage products of A10 and A8 were 11-OH-KS and 11-ketone-KS respectively. Band A<sub>3</sub> was found to give 25% 11-OH-KS, 40% 11-ketone-KS, and 30% was present in two peaks with chromatographic properties similar to those of c-19-12.

The cortol region (A-2) yielded 50% 11-OH-KS and

TABLE 3-19

Chromatography of acetylated  $\alpha$ - and  $\beta$ -cortols in the  
 20// CHCl<sub>3</sub>/ EtOAc/ H<sub>2</sub>O system

Component	Ac-1	Ac-2	Ac-3	Ac-4	Ac-5	Ac-6	Ac-7
$\beta$ -cortol	50	(60)	57			61	69
$\alpha$ -cortol	50			43	(77)	81	88
contaminant			50				
cortisol	52						

TABLE 3-20

Bismuthate oxidation of total c-21 fraction

17-ketosteroid formed	11OH-E	11OH-A	c-19-12	11KE-11KA
percent of the total ketosteroid	60	12	11	12

TABLE 3-21

$\Delta R_{Fr}$  values for the 11-ketone reduction of some  
 17-ketosteroids

component	R <sub>f</sub>	R <sub>F</sub>	$\Delta R_{Fr}$ (11=1 $\rightarrow$ 11=0)	$\Delta R_{Fr}$
11-K-A	0.81	-0.494	-0.73	
11-OH-A	0.225	0.534		
11-K-E	0.52	-0.036	-0.80	
11-OH-E	0.145	0.753		
c-19-12	0.305	0.354		-0.75
$\Delta 1$ -keto- steroid	0.075	1.104		
11-K-E $\rightarrow$ c-19-12				0.39
11-OH-E $\rightarrow$ $\Delta 1$ -ketosteroid				0.34

25% 11-ketone-KS with some 15% of c-19-12.

Oxidation of the most polar band (A-1) produced 20% 11-OH-KS, 10% 11-ketone-KS and 55% of a compound less polar than E but more polar than 11-OH-Etiocholanolone. The R<sub>F</sub> values of the four authentic ketosteroids, c-19-12 and the A-1 oxidation product, are set out in table, 3-21, together with the R<sub>M</sub> and AR<sub>M</sub> values. The good agreement between AR<sub>M</sub> values would indicate the ketosteroid of A-1 is the 11b-OH derivative of c-19-12. (see section 3.3)

The apparent presence of 11-ketone compounds in the region of the cortols should be questioned. This may be an artifact due to atmospheric oxidation (Bush and Ferguson, 1953); or by the action of sodium bismuthate. On the other hand, such oxidations with sodium bismuthate have not been reported by other investigators, or observed in this laboratory.

### 3.7 Quantitation of c<sup>14</sup>-21 Metabolites

To measure the relative quantities of each c<sup>14</sup>-21 metabolite present in the free steroid extract, the total c<sup>14</sup>-21 fraction was subdivided by chromatography into two fractions (series A, series B). Further subdivision was in accordance with fig. 3. A similar procedure was followed to that of the c-19 determination except that autoradiography was used exclusively for location of the bands after chromatography. Results expressed as a percentage of the total free steroid extracted is presented in table, 3-18.

### 3.8 An Investigation into Pathways of Cortisol Metabolite Excretion in the Sheep

Radioactive cortisol metabolites were collected from the urine and bile in the case of surgically modified sheep, or from the urine only in the case of normal whole sheep.

In experiment -1 a normal sheep was injected

intravenously (I.V.) with 4-c<sup>14</sup>-cortisol and radioactive metabolites collected in the urine only. In experiments -2, -3 a sheep with cannulae surgically implanted in the bile system and duodenum was used (see, 2.2), and radioactive metabolites collected in bile and urine.

Before experiment -2 and -3 were started, the urinary metabolite pattern after an injection of 4-c<sup>14</sup>-cortisol was checked with an external tube short circuiting the bile outflow directly into the duodenum. The pattern so obtained was essentially identical to that obtained from the sheep used in experiment -1.

### 3.8.1 Expt.-1 Urinary Excretion of 4-c<sup>14</sup>-F Metabolites in the Whole Sheep

#### 3.8.1.1 Administration of F to the Sheep

About 10 uCi of 4-c<sup>14</sup>-F (dissolved in 10% EtOH in benzene) was evaporated to dryness at 50°C under a stream of dry N<sub>2</sub> and redissolved in 1 ml. of warm ethanol. This was diluted to 10 ml. with sterile saline and appropriate aliquots removed for accurate measurement of the radioisotope present. The radioisotope in saline (10 ml.), was injected into the jugular vein of the sheep.

#### 3.8.1.2 Data collection

The urine was collected from the sheep for 3 days and the collection bottle was changed after each 24 hours. The radioisotope excreted in each 24 hours was determined by counting of appropriate urinary aliquots in Brays scintillation fluid. The degree of scintillation quenching by the urine components was assessed after the addition of a measured quantity of 4-c<sup>14</sup>-F to the counting vial. Results are presented in table, 3-22. Only the first 24 hour collection was retained for metabolite analysis, the results of which appear in section 3.1 to 3.7.

### 3.8.2 Expt.-2 Excretion of 4-c<sup>14</sup>-Ketosteroid in the Bile and Urine of the Sheep

This experiment was designed to determine if any difference exists between the pathway of excretion of ketosteroid (and possibly c-19 metabolites in general) and pregnane derivatives of cortisol. The cortisol was reduced in ring A before sidechain cleavage to simulate more closely the actual metabolites involved in the sheep.

About 3 uCi of 4-c<sup>14</sup>-F was reduced with NaBH<sub>4</sub> for 12 hours at room temperature, and then the side chain was removed with sodium bismuthate. The ketosteroids produced were separated from any remaining c-21 compound by passing the mixture through a florisil column, and retaining the c-19 fraction. The yield of c-19 compounds was 75%.

Three products -A-4-ene-3b,11b-ol-17-one (40%, Rf 0.91), A-4-ene-11b-ol-3,17-one (35%, Rf 0.78), and 5a-A-3b,11b-ol-17-one (25%, Rf 0.61); were detected by scanning the SG-GE254 thin layer plate after development in the CHCl<sub>3</sub>/EtOH/H<sub>2</sub>O (174:26:2) (Rf-test, 0.80; Rf-cortisol, 0.28).

Approximately 1 uCi of the ketosteroid mixture was administered I.V. to the sheep. The bile and the urine was collected for 24 hours. After the radioactivity being excreted in the urine had dropped to a negligible amount (3 days), 1 uCi of the KS was infused into the duodenum, and the urine collected for 24 hours.

Recovery of radioisotope is shown in table,3-23. A brief qualitative investigation was made of the radio-compounds present in the bile and urine collected.

The I.V.Bile was shown to contain compounds more polar than cortisol (triols) in the kieselghur partition system, (system 2.7.2.1a) with the majority (70%) of the radioactivity contained between cortisol and cortisone in the same system (11-ketone-diols). (Main peak Rf<sub>E/F</sub> of 0.3)

TABLE 3-22

Urinary excretion of radioisotope following the I.V. administration of 4-c<sup>14</sup>-cortisol

Time of collection	0-24 hrs	24-48 hrs	48-72 hrs
Radioisotope found in each collection as a percent of dose	77%	5%	0.8%

TABLE 3-23

Treatment of c<sup>14</sup>-metosteroid by the surgically modified sheep

Path of administration	Measurement made on -	Percent recovered over 24 hours
1 uCi 4-c <sup>14</sup> -metosteroid I.V. by injection	Bile	59%
	Urine	13%
1 uCi 4-c <sup>14</sup> -metosteroid intraduodenal by inject.	Urine	60%

TABLE 3-24

Urinary and biliary excretion of I.V. 4-c<sup>14</sup>-cortisol

Part	Path of admin.	Measurement made on -	1st 24 hrs		2nd 24 hrs	
			%* recov.	B U †	% recov.	B U
A <sub>1</sub>	3 uCi c <sup>14</sup> -F, I.V.	Urine	30%	1.8	3.5	1.9
		Bile	53%		0.5	
A <sub>2</sub>	c <sup>14</sup> -F metabol. intraduodenal infusion	Urine	25	2.0	4	2.7
		Bile	90		11	
B <sub>1</sub>	10 uCi, I.V.	Urine (IVU) †	35	1.9		
		Bile (IVE)	62			
B <sub>2</sub>	intraduodenal infusion	Urine (IFU)	33	1.6		
		Bile (IFB)	51			

\* percent recovery of radioisotope injected or infused

† see text

‡ Abbreviation for Expt. 3, part c

No triols were detected in the I.V. Urine extract with virtually all the radioactivity lying between F and E. The major peak was observed at  $R_{E/F} = 0.7$ .

The I.F. Urine was shown to have present a range of compounds including triols and 3-hydroxylated ketosteroids, with the majority of radioactivity contained in the 11-ketone-diol region.

Chromatography of each extract in the system SG-GF254//CHCl<sub>3</sub>/EtOH/H<sub>2</sub>O (174:26:2, 2.7.2.2c) revealed a complete absence of both unsaturated steroids (spray, 2.7.3.2.1a).

### 3.8.3 An Investigation of the Pathways of Cortisol Excretion in the Sheep

#### 3.8.3.1 Expt.-3A Urinary and Biliary Excretion of I.V. 4-c<sup>14</sup>-F

Approximately 3 uCi of 4-c<sup>14</sup>-F was injected (I.V.) into the sheep. The urine and bile were collected for 48 hours (2 x 24 hours), while precollected bile was pumped into the duodenum at the normal rate.

When the urine was free of radioactive material (3 days), two thirds of the first 24 hour collection of bile (stored at 0°C) was pumped into the duodenum at a faster than normal rate (35 ml./hour) over 3 hours. Both the bile and urine were collected for 48 hours (2 x 24 hours) from the start of infusion.

The percentage recovery of radioisotope at each step, and the ratio of metabolite excretion between bile and urine, forms part A of table, 3-24.

#### 3.8.3.2 Expt.-3B Urinary and Biliary Excretion of I.V. 4-c<sup>14</sup>-F -Repeat

This experiment was a repeat of expt. 3A except for the following modifications. Approximately 10 uCi of 4-c<sup>14</sup>-F was injected I.V. into the sheep and bile and urine was collected for only 24 hours. Similarly, two thirds of the 24 hour bile collection (also about 300 ml.) was pumped into the duodenum and a 24 hour

bile and urine collection made. The quantities of radioisotope excreted in each phase of the experiment are presented in part B of table, 3-24.

3.8.3.3 Expt.-30 A Qualitative and Quantitative Investigation of Metabolites Excreted in Bile and Urine following I.V. 4-c<sup>14</sup>-F, and Intra-duodenal 4-c<sup>14</sup>-F biliary metabolites

Each of the four collections forming part B of expt. 3, (IVU, IVB, IFU, and IFB) were subjected to a similar form of analysis to the metabolites from expt.-1. Due to the nature of this section only the structures of the major metabolites, or those of special interest, were confirmed. The following discussion is qualified by table, 3-25.

IVB The large amount of EHF and cortols is a predominant feature, as in the relative absence of 17 hydroxylated compounds.

IVU The relatively large amounts of c-21-A1 and -A3 found in this excretion as compared to the virtual absence in IVB, is worthy of note.

The c-19-diols were reduced with NaBH<sub>4</sub> and chromatographed in the SG-GF254//EtAc/cyclohexane (1:1, 5 hours; 2.7.2.2d) system. The IVU-c-19-triols were also chromatographed in the same system. The same compound was detected in both cases, and was identified as 5b-A-3a,11b,17b-ol, by its chromatographic properties in this system.

IFB The major metabolites of F in this excretion were c-19-diols, and triols.

Chromatography of the triols in the SG-GF254//EtAc/cyclohexane system (1:1, 5 hours; 2.7.2.2d) resulted in isolation of the 5b-A-3a,11b,17a-triol with a small amount of the 5a-A-3a,11b,17a-triol (0.4% of total metabolites) also present. No 5b-A-3a,11b,17b-ol

TABLE 3-25

Quantitative analysis of Experiment- 3

Individual component	Collection values expressed as percent of total *			
	IVB	IVU	IPB	IPU
c-21-A1	-	0	-	-
controls	21	10	6	10
c-21-A5	-	4	1	2
c-21-A4-- A7	-	2	2	2
controlones	4	4	2	3
JHF	31	12	11	11
c-21-A11	9	4	2	2
c-21-B1	-	-	1	1
THE	9	0	4	3
c-19-11bOH-triols	2	4	22	10
c-19-11ketone-diols	3	0	20	29
11-OH-steroids	0	0	11	14
c-19-12	3	3	2	3
11-K-E	3	7	0	5
11-K-A	6	2		
c-19-11b,17a-triol	2	-	22	10
c-19-11b,17b-triol		4	-	
c-19-17a-ol-11-one	3	-	20	29
c-19-17b-ol-11-one		0	-	

\* to the nearest 1%

Fig 3.6 a

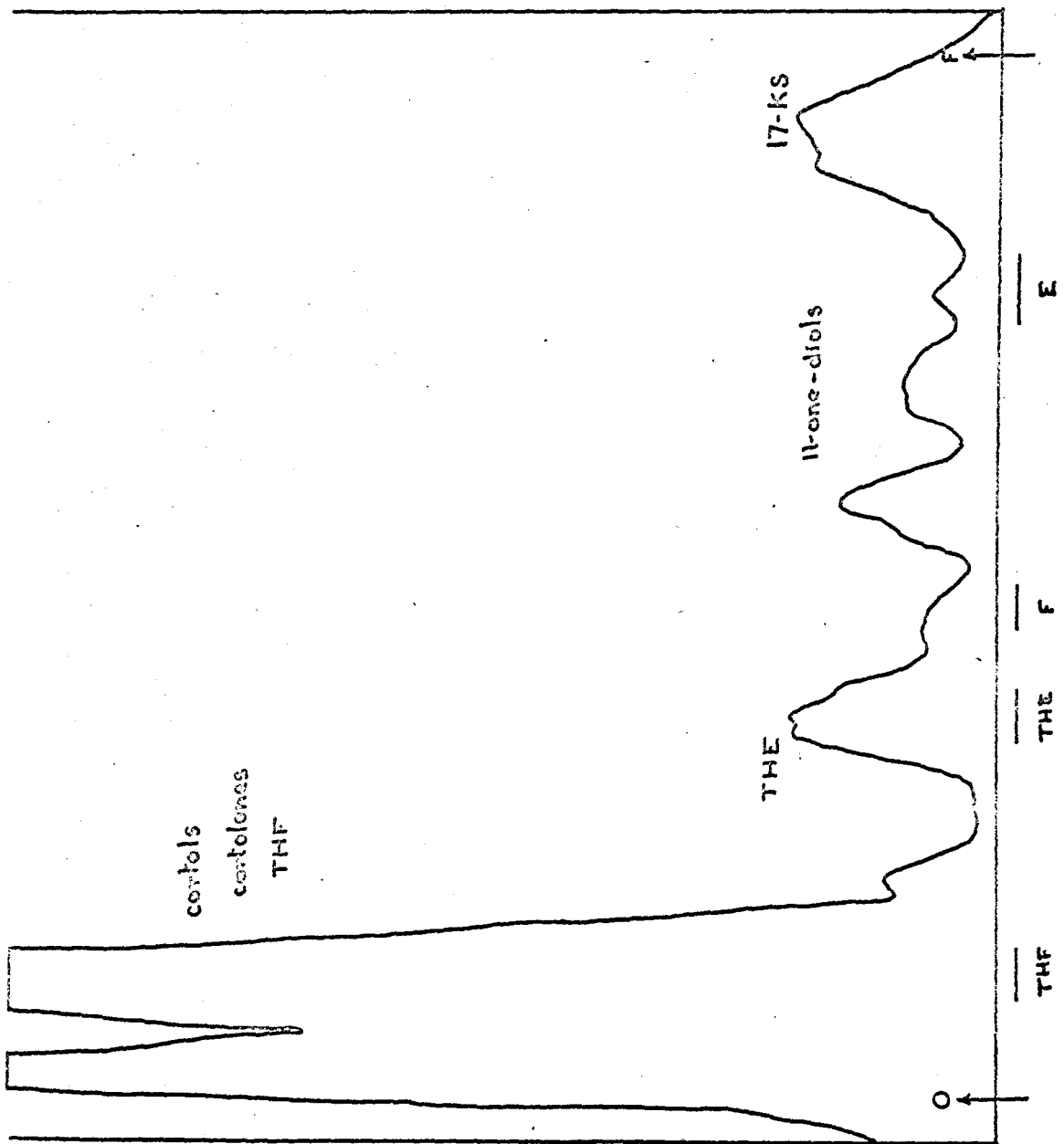

IVB

Scan of IVB collection following T.L.C. in the system Kg/ glycol/  $\text{CH}_2\text{Cl}_2$

Fig 3.6 b

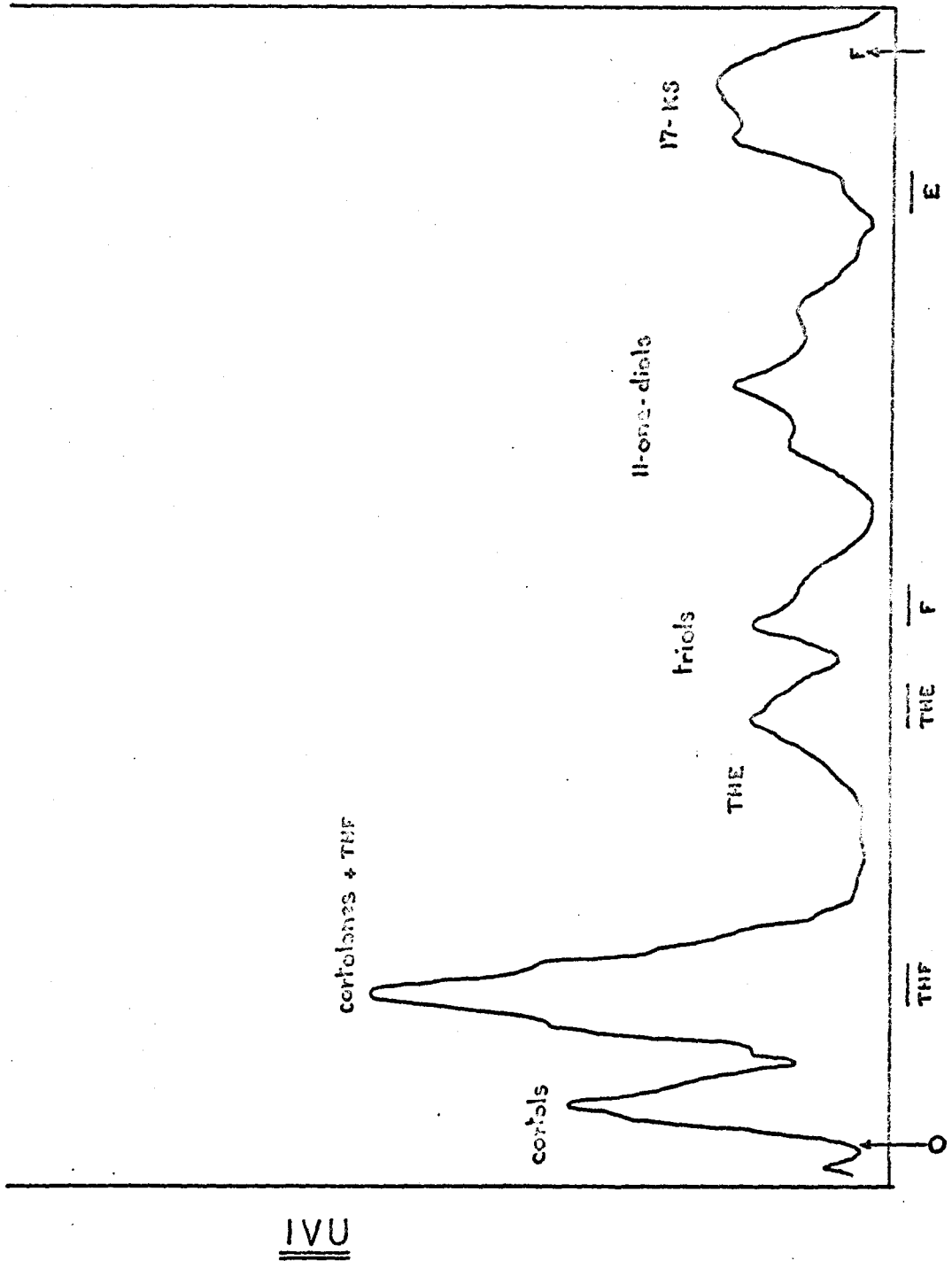

Scan of IVU collection following T.L.C. in the  
system Kg/ glycol/  $\text{CH}_2\text{Cl}_2$

Fig 3.6 c

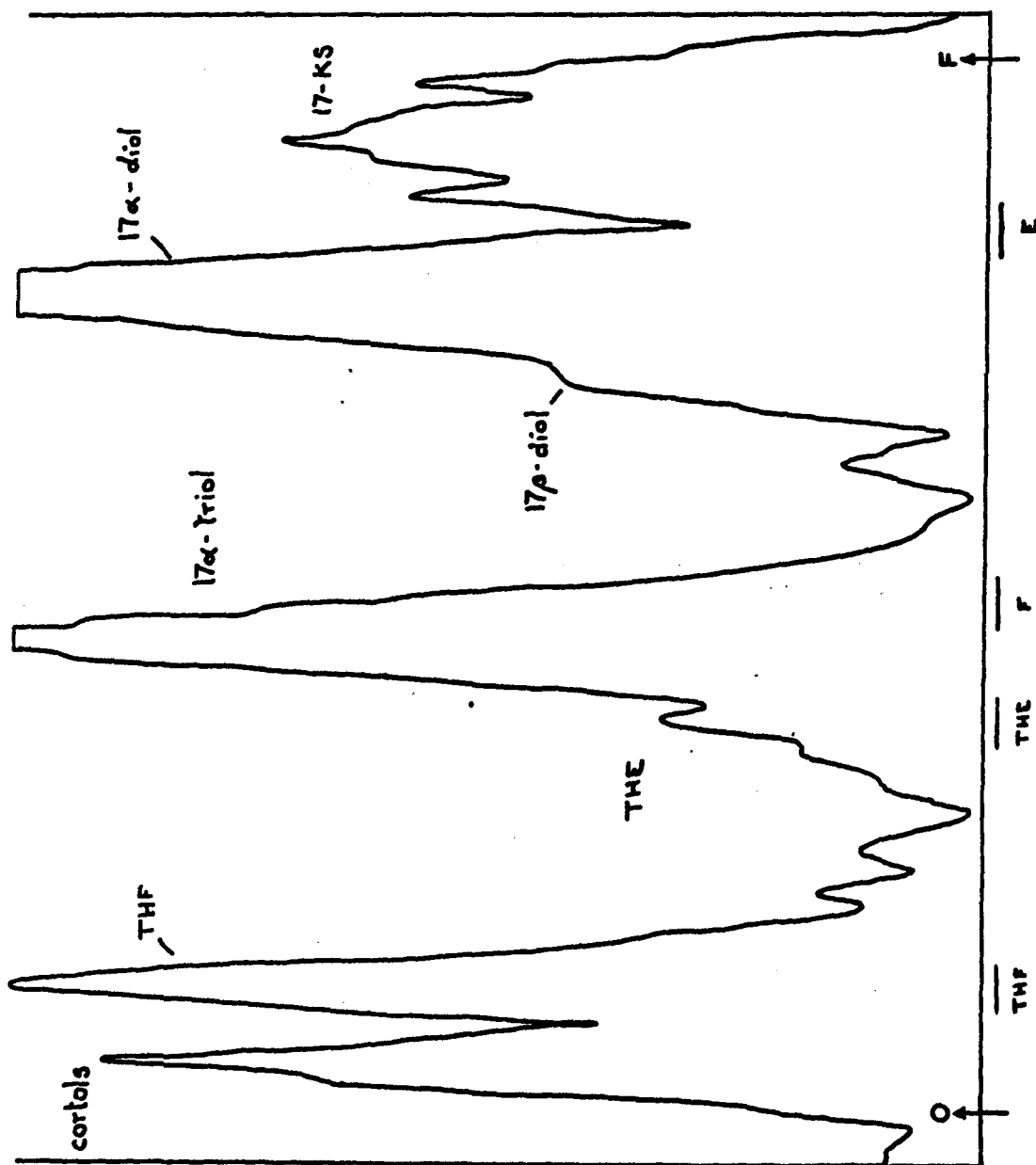

IFB

Scan of IFB collection following T.L.C. in the  
.system Kg/ glycol/ CH<sub>2</sub>Cl<sub>2</sub>

Fig 3.6d

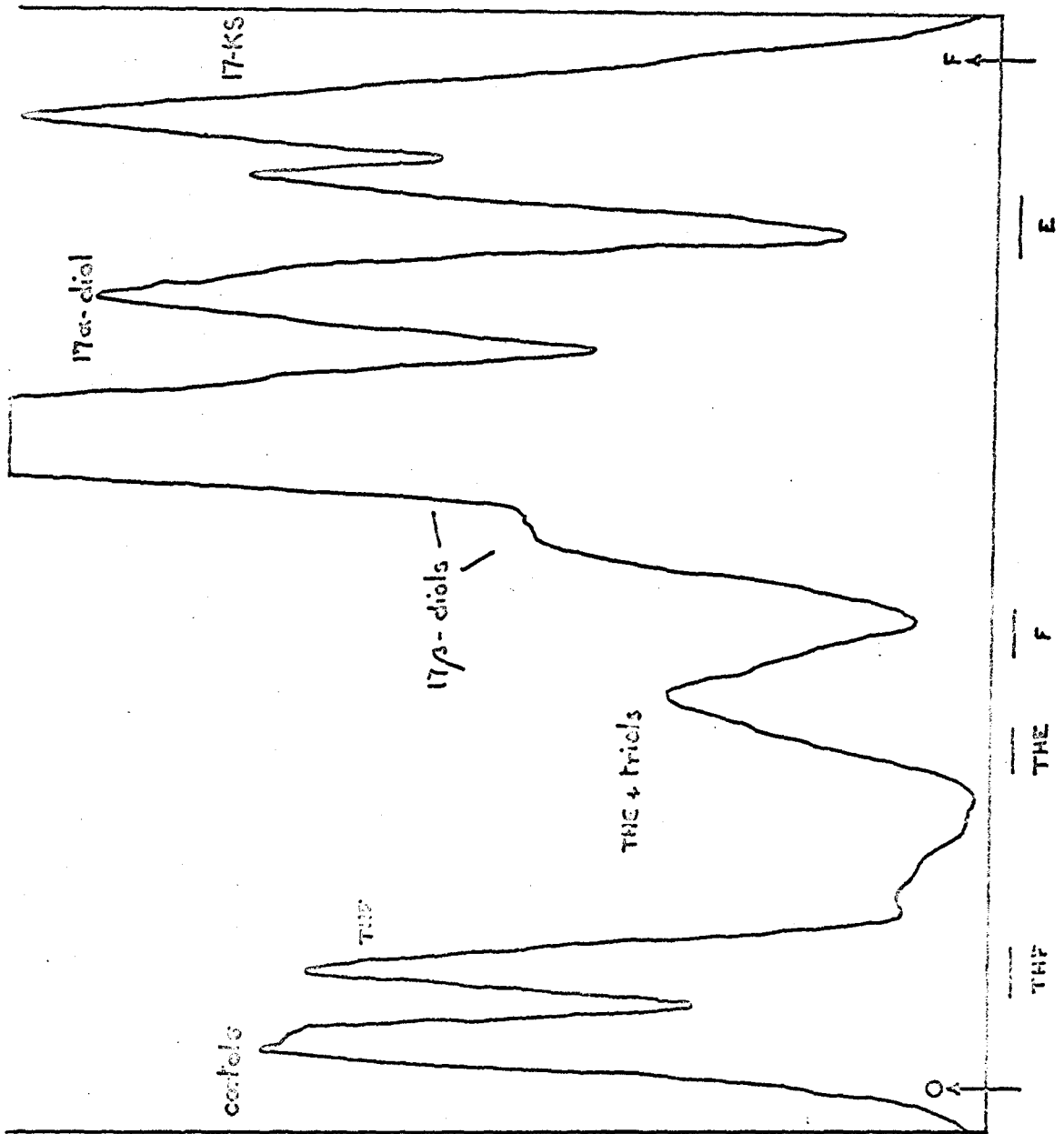

IFU

Scan of IFU collection following P.L.C. in the  
system Kg/ glycol/ CH<sub>2</sub>Cl<sub>2</sub>

was observed. Reduction of the c-19-diols gave predominantly 5b-A-3a,11b,17a-ol, with a trace (0.5% of total metabolites) of the -17b-isomer.

IFU The very polar c-19 compounds were again predominant in this excretion. After reduction of the 11-ketone-c-19-diols it was seen that both the -17a- and the -17b- compounds were present in considerable quantity. However the 5b-A-3a,17a-ol-11-one isomer was still the greater constituent.

Partial fractionation of each collection and quantitation of individual components, resulted in values reported in table,3-25.

### 3.9 An Investigation of the Diurnal Variations in Urinary Cortisol Metabolite Excretion in the Sheep

The urine was collected continuously from a catheterised female sheep. The flow was directed into one of 24 labelled bottles, and changed on the hour to the next bottle, using a fraction collector attachment. Bottles were emptied twice daily into a refrigerated stockbottle labelled with the appropriate hour, resulting in a set of 24 pooled specimens, one for each hour of the day.

The collection was terminated after 18 days and the urine volume in each of the 24 bottles measured. (fig. 3.6) Cortisol-4-c<sup>14</sup>,71,500 d.p.m., in 10 ml. of 95% EtOH, was added to each bottle and mixed thoroughly.

In the processing that followed the numerical sequence of the pooled samples was changed with each treatment step, to reduce day to day inconsistencies. Each sample was treated as follows:-

Ammonium sulphate (300 Gm/litre urine) was dissolved by warming (30°C), and with the temperature again lowered to less than 10°C the pH was slowly adjusted

to 1.5 with conc. HCl (usually 30-40 ml./litre urine). This was shaken twice for 5 minutes with half volumes of EtOH/Et<sub>2</sub>O (1:3), and the aqueous layer centrifuged if an emulsion persisted. The pooled organic solvent was dried with anhydrous sodium sulphate, and removed under vacuum, at room temperature. The conjugates were transferred to an erylinmeyer flask with 25 ml. of 0.5 M acetate buffer (pH 4.6) and brought to a final volume of 100 ml. with buffer washings. Kieslgur powder (3 Gm), and b-glucuronidase enzyme (370,000 u), were added before incubating for 24 hours at 37°C, with occasional shaking.

The contents of the flask were washed out into a 1 litre separating funnel with 50 ml. of saturated sodium sulphate solution and the free steroids extracted (5 minutes) with 2 x 200 ml. ethyl acetate. The pooled organic solvent was washed with 50 ml. of 3 M NaOH, followed by 50 ml. of distilled water, and then dried with anhydrous sodium sulphate (15 Gm). the ethyl acetate was removed under vacuum with a rotary evaporator and the residue dissolved in 5 ml. of ethanol free chloroform.

The ketosteroids present and the C<sub>15</sub>O<sub>3</sub>, strongly B.T.Z. positive compound, were rejected as the c-19 fraction off a florisil column. The c-21 corticosteroids were then recovered with further elution from the column. After removal of the CHCl<sub>3</sub>/MeOH solvent, the steroids were dissolved in 10 ml. of chloroform for quantitation.

### 3.9.1 Quantitation of Blue Tetrazolium Chromogens

Appropriate aliquots (0.1 - 0.5 ml.), of each sample, were used for scintillation counting of radioisotope present. Suitable volumes (0.05 - 0.2 ml.) were assayed for a-ketols, and quantities were expressed as ugm of Blue Tetrazolium Chromogen equivalent to THF, per 1000 d.p.m. (see fig.3.7).

Fig 3.7

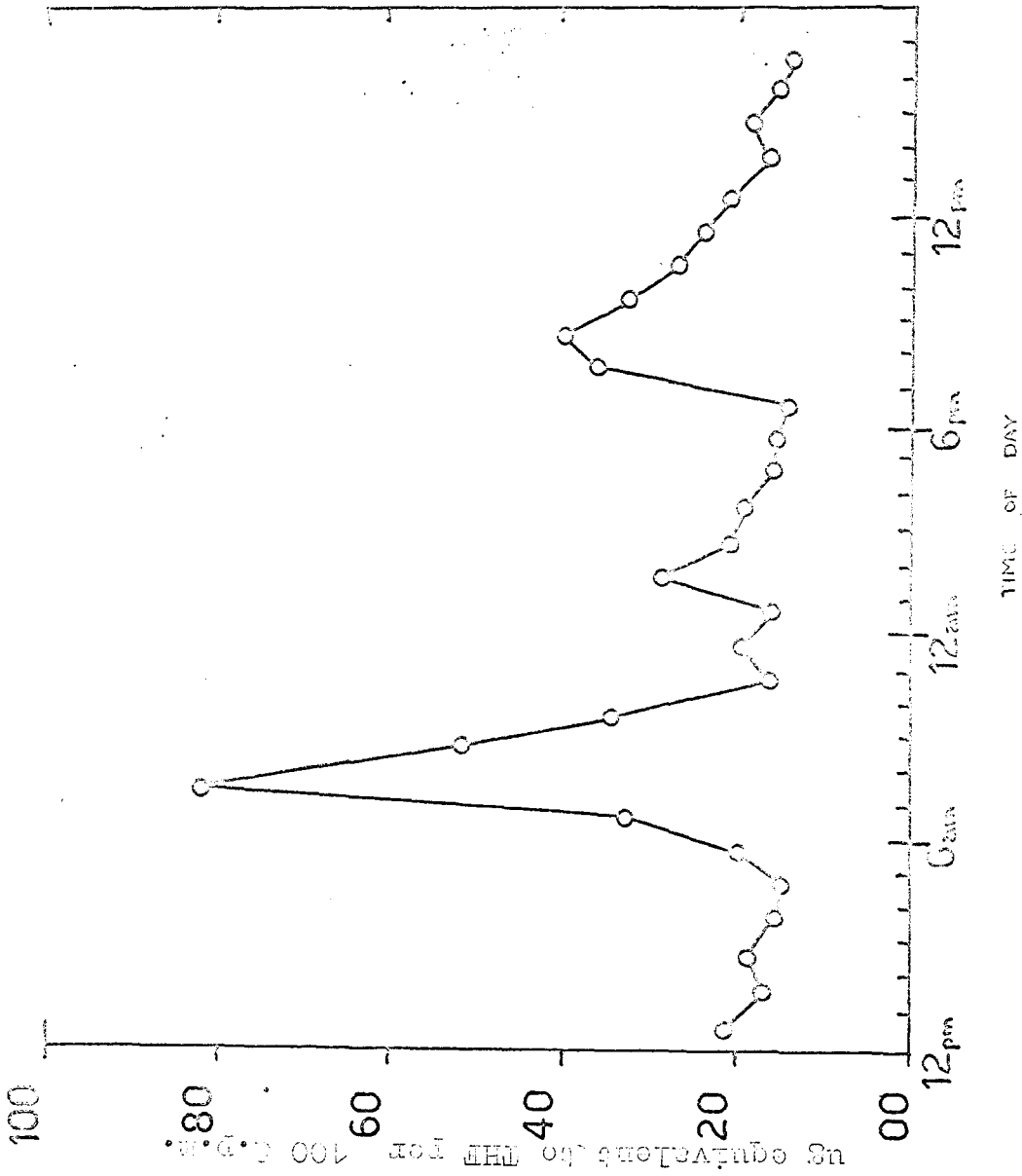

24 hour urinary excretion pattern of c-21 metabolites of cortisol - specific measurement of -17a,21-ol-20-one compounds (blue tetrazolium chromogen)

### 3.9.2 Quantitation of Zimmerman Chromogens

The steroid from half (5 ml.) of the chloroform solution of c-21 corticosteroids was recovered and redissolved in 50% aqueous acetic acid for oxidation with sodium bismuthate. The ketosteroids were extracted with benzene/hexane (1:1, 2 x 10 ml.), and after drying and removal of solvent, were redissolved in 15 ml. of 2.5% MeOH in  $\text{CHCl}_3$ . This solution was run through a 4 cm x 1 cm florisil column followed by 10 ml. of 2.5% MeOH in  $\text{CHCl}_3$ . Suitable volumes of the eluant were taken for the ketosteroid assay and radioactivity determination. The degree of colour quenching in the ketosteroid determination was estimated with up to 50  $\mu\text{g}$  DHEA added to duplicate sample volumes. Quantities were expressed as  $\mu\text{g}$  of Zimmerman chromogen equivalent to DHEA, per 1000 d.p.m. (see fig.3.8).

--- /- / ---

Fig 3.8

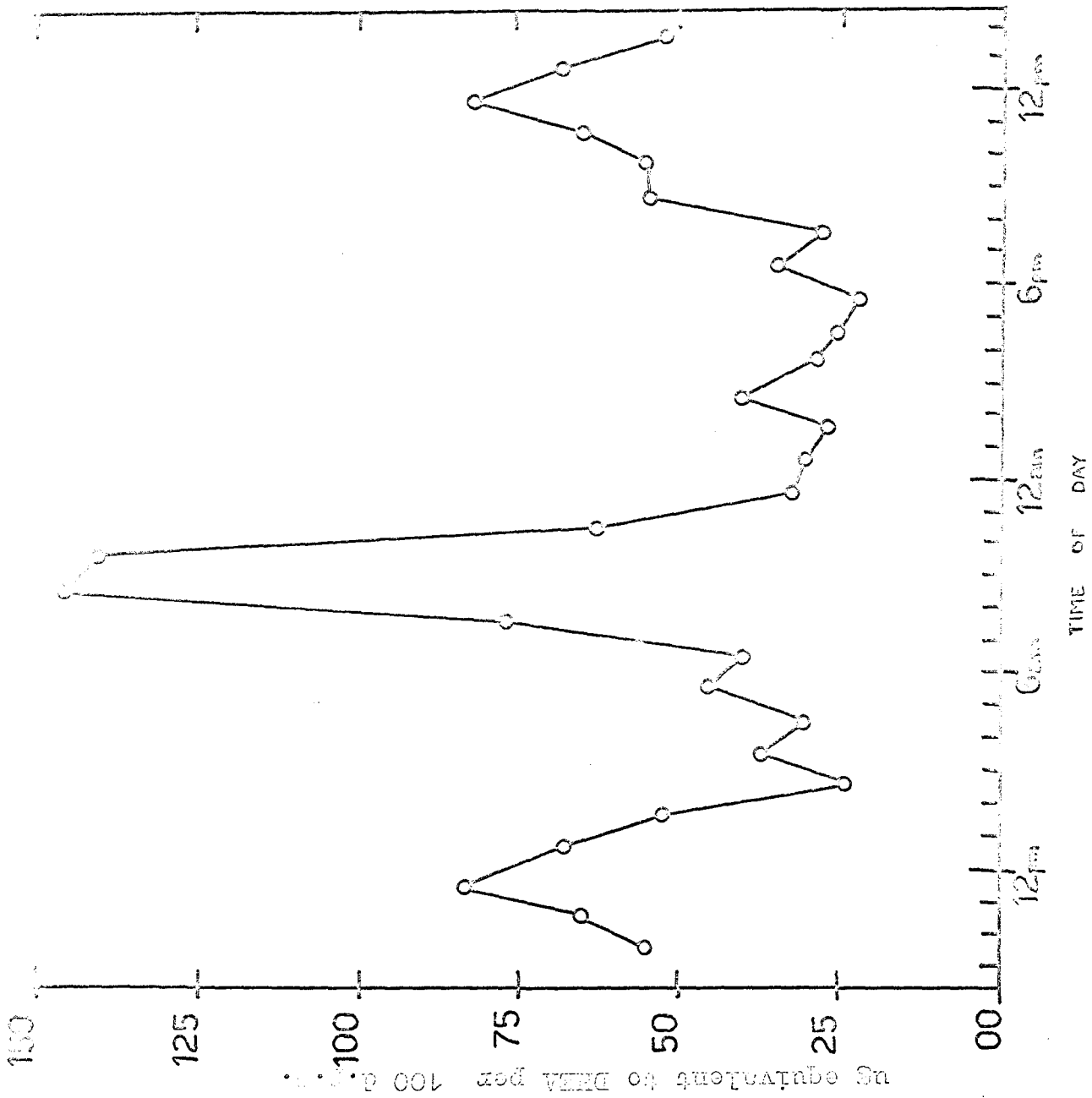

24 hour urinary excretion pattern of c-21 metabolites of cortisol - specific measurement of -17a,21-ol-20-one and -17a,20,21-ol compounds (Zimmerman chromogen)

Fig 3.9

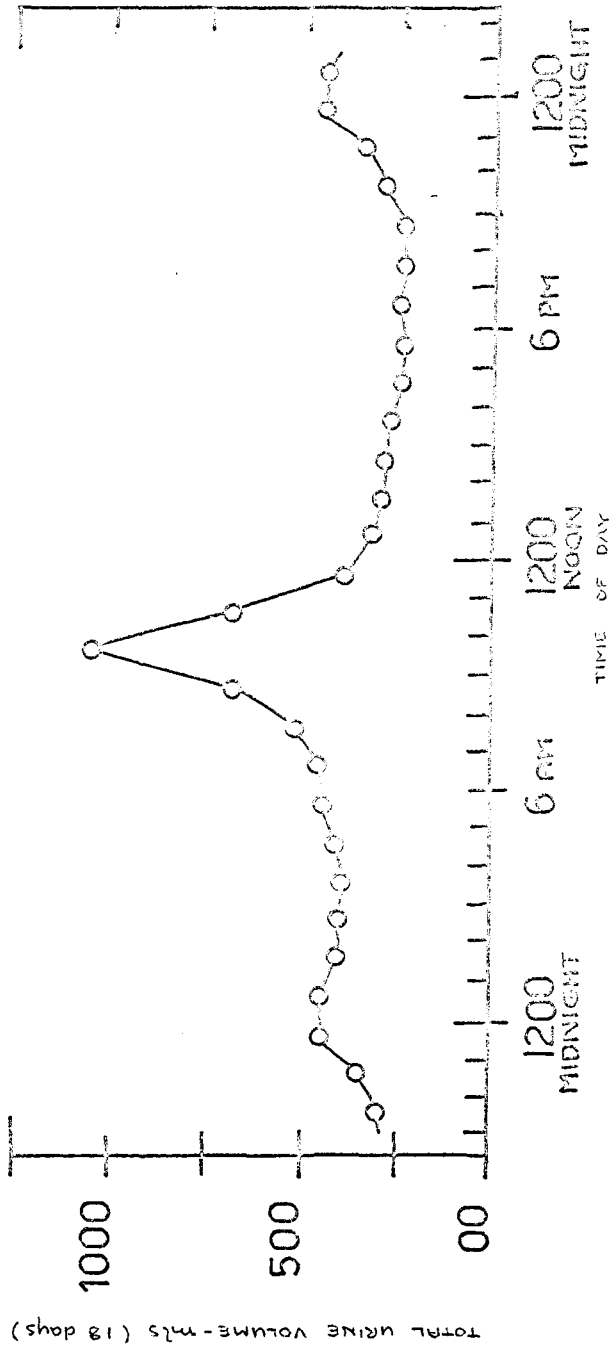

Pattern of urine volume over duration of the diurnal metabolite excretion experiment

## Chapter 4

DISCUSSION4.1 Hydrolysis of Steroid Conjugates4.1.1 Acid Hydrolysis

The most commonly employed procedure for complete hydrolysis of steroid conjugates (both glucuronide and sulphate) involves treatment with mineral acid at an elevated temperature. Destruction or alteration of some steroids can occur along with the production of pigments from urinary material which are difficult to remove and which interfere with subsequent colorimetric estimations. Transformations are to be avoided if fractionation is contemplated, and even with colorimetric estimations alteration of the molecule remote from the chromogenic group may influence the absorption spectra and extinction coefficients.

Hydrochloric and sulphuric acids are used almost exclusively with adjustment to between 1 and 3 N, although up to 7.2 N has been used for continuous extraction at room temperature. The time of hydrolysis, final temperature and whether the sample is acidified cold or at the final temperature are all variables which have received much attention. The conditions used for preliminary work in this investigation appear to be optimum and were similar to those used by Bray and Merivale(1953).

For the hydrolysis of nonfragile 17-KS-glucuronides, acid hydrolysis is quite satisfactory and rapid, but for the more delicate corticosteroid metabolites being investigated in the urine of the sheep, enzyme hydrolysis was preferred.

4.1.2 Enzyme Hydrolysis

The enzyme hydrolysis of steroid conjugate was

first observed through the action of bacteria on urinary estrogen conjugates (Cohen, 1934), and the enzyme was later extracted from E. Coli. The b-glucuronidase responsible has since been isolated from rat liver and calf spleen (Cohen, 1951).

Extracts of univalve shellfish are known to have considerable quantities of both aryl sulphatase and b-glucuronidase in their visceral parts (Orzel, 1967). Although the limpet has twice the activity of b-glucuronidase per gram of tissue (wet weight), the paua is by far the most satisfactory source due to its ease of collection and large bulk. Although aryl sulphatase is present in both paua and limpet, no enzyme has yet been discovered which will catalyse the hydrolysis of the sulphates of non-benzenoid steroids.

The enzyme from the New Zealand paua, Haliotis iris, was very active towards glucuronosides of the cortisol metabolites found in the sheep urine and the release of aglycone was completed after as little as 2 - 5 hours with 12,000 u/ml. and 6 hours with 6000 u/ml. No inhibition of the enzyme activity was observed when the hydrolysis was performed in untreated urine.

The paua enzyme was particularly stable with little loss of activity from fractionating at room temperature compared to following the same procedure at 0°C. Storage for long periods at 4°C in pH 4.5 buffer resulted in no loss of activity. The optimum pH for the paua enzyme towards phenolphthalein glucuronide was 4.5 which is in keeping with the optimum of 4.2 - 4.7 for limpet, 5.2 for snail, and 4.5 for preputial gland preparations assayed at 37°C. Bacterial enzyme has an optimum activity close to neutrality.

As far as is known at the present time the enzymatic hydrolysis of steroid glycosiduronic acids leads to the release of the free steroid without concomitant formation of transformation products, and is therefore particularly suited to the present study.

#### 4.2 Extraction of Conjugated Steroids

The polarity of a steroid conjugate depends on the form of conjugation, the nature of the steroid, and position of the glucuronic or sulphuric acid attachment. They are very water soluble and special techniques using polar solvents must be used for extraction.

Conjugates have been extracted from neutral solution using n-alcohols with 3 - 8 carbons (Cohen et al, 1938) although the addition of salt usually favours extraction. Low pH also favours extraction of conjugate but may also lead to the extraction of significant amounts of impurities.

Optimum conditions were found to be similar to those used by Edwards et al (1953) whereby the steroid conjugate was extracted from aqueous solution after the addition of 50%  $(\text{NH}_4)_2\text{SO}_4$  and adjustment to pH 1, by alcohol-ether (1:3). Further extraction using butanol solvent for the extraction of very polar conjugates and diconjugates (Kornel, 1963) was found unnecessary in the present investigation when preceded by the alcohol-ether extraction.

More recently systems using Sephadex (Hanel, 1965) and ion exchange resins (Kushinsky and Tang, 1963) have given the same order of extraction from urine as the method of Edwards et al (1953).

#### 4.3 Extraction of Free Steroid

Extraction of the free steroid from aqueous solution usually involves the use of solvents 'tailored' to suit the steroid being extracted. For the extraction of the polar steroids encountered in sheep urine a system was developed using ethyl acetate as the extracting solvent with the addition of sodium sulphate to the aqueous solution of steroid while retaining the pH of about 4.5. The extraction procedure outlined in fig.2-6 gave a recovery of about 80% and little was lost in the alkali wash used to remove estrogen and some acidic chromogenic material. The main loss of

radioactivity was through retention of steroid in the aqueous incubation mixture due to either:-

- (a) incomplete hydrolysis of glucuronides
- (b) presence of steroid sulphates or other forms of conjugation
- (c) incomplete extraction - although the extraction procedure was shown to give consistently almost complete recovery of THF from aqueous solution.

Fukushima *et al* (1950) have found that only 77% of the urinary 4-c<sup>14</sup>-cortisol metabolites were released as aglycone with  $\beta$ -glucuronidase hydrolysis, and this compares well with the 80% in the sheep, although Holm and Firch (1955) found the proportion of glucuronide bound steroid in bovine urine is variable and generally less than that found in man. As the form of conjugation of the urinary cortisol metabolites of the sheep is unknown this remains the basis for further investigation and it must be accepted that at present there is no one method that can give satisfactory hydrolysis of all urinary conjugates.

#### 4.4 Chromatographic Analysis of Corticosteroids

In this investigation the steroids appeared almost exclusively in pairs differing only in the degree of reduction at c-11 or as a- and b-isomers. Bate-Smith and Westall (1950) developed a relationship between pairs of compounds termed  $\Delta R_M$  values where  $R_M$  is given as  $\log_{10}(1/R_f - 1)$ . The function  $(R_f - 1)$  is directly proportional to the partition coefficient between the stationary and mobile phases in a chromatographic system of the solute, and the chemical potential of a solute is related to the logarithm of this value.

In this investigation,  $\Delta R_M$  values were obtained for a variety of relevant structural changes, from the authentic compounds available. The values obtained from the glycol partition were remarkably consistent, and could be confidently applied to single group differences between the relatively unusual steroids

encountered (see chapter 3).

#### 4.5 Route of Disposal of Cortisol in the Sheep

The principal route of ultimate disposal of exogenous 4-c<sup>14</sup>-cortisol in the normal sheep is by the urine (83% recovery over 3 days). However an enterohepatic recirculation is present in the sheep (Lindner, 1965), which although apparently not affecting the ultimate disposal of cortisol to any great extent, has considerable importance in determining the nature of cortisol metabolite excretion in the urine.

The major proportion of the 4-c<sup>14</sup>-cortisol administered I.V. to the sheep was excreted in the bile, with the remainder appearing in the urine. From the first 24 hour collection the bile/urine excretion ratio was 2 and subsequent collections showed little variation from this ratio. Rodents have a predominant urinary route for 4-c<sup>14</sup>-c-21 corticosteroid elimination following I.M. or intra-peritoneal injection of 4-c<sup>14</sup>-cortisol, but the major route is via the bile following I.V. administration (Bradlow et al, 1954b). Biliary excretion of corticosteroids in ruminants has been reported. Wynne (1954) found only 15 ug of cortisol per litre of bile in a normal sheep but this was increased to 600 ug/litre in sheep dying from inanition (lack of nutrition). A similar effect has been observed in humans (Mason, 1950) where adrenal hyperactivity, or artificially induced higher levels of plasma ACTH than normal, may cause up to 5 mgm of cortisol/24 hours to be excreted by way of the bile. Under these conditions, the bile appears to be the principal route of cortisol excretion.

The recovery of radioactivity in the bile and urine, following an I.V. injection of 3 uCi of 4-c<sup>14</sup>-cortisol was 93% over 2 days in one experimental sheep, and 95% in first 24 hours in a second sheep given 10 uCi of 4-c<sup>14</sup>-cortisol, I.V. This high recovery can be compared with the 83% of radioactivity accounted

for in the urine of an intact normal sheep over 3 days although this implies a loss of 10 - 20% in the feces, the fact that 60% and 62% of the radioactivity in the two sheep respectively was excreted through the bile, confirms that a considerable reabsorption of radioactivity from the gut must have occurred. These values agree closely with Fukushima et al (1960) who recovered 55% of the radioactivity, from 4-c<sup>14</sup>-F injection in the human, in the first 24 hours.

Enterohepatic recirculation of cortisol metabolites has been reported in rodents (Hyde and Williams, 1954), in the guinea pig (Wynngaarden et al, 1955), and in the sheep (Lindner, 1965). In the sheep studied, 90% and 84% of the biliary cortisol metabolites respectively, were reabsorbed over the period studied, 60% of which is again excreted in the bile. It follows that with a 10% loss per cycle, and 60% of that absorbed being recycled, this would finally give a urinary excretion of 70 - 80% of any exogenous or endogenous cortisol in the normal sheep. This reabsorption of c-21 metabolites in the sheep, is consistent with the observation of Wynne (1954) who was unable to find any corticosteroid in the feces of a normal sheep.

However, androgenic activity has been reported in the feces of cattle, and Miller et al (1956) found that exogenous progesterone was eliminated almost quantitatively in the feces. A similar situation was found in the rat, with 80% elimination of progesterone in the feces as 17-ketosteroid (Bloch et al, 1954).

The distribution of 17-ketosteroid in the sheep was investigated through both I.V. and duodenal administration of 4-c<sup>14</sup>-17-ketosteroid. Following I.V. dosage with ketosteroid 69% was excreted in the bile in the first 24 hours with only 13% in the urine over the same period. This gives a biliary urinary ratio of almost 4. This is twice that obtained from 4-c<sup>14</sup>-cortisol under the same conditions, indicating a possible selective excretion of cortisol metabolites

through the biliary pathway, favouring the less polar metabolites, or more specifically, the c-19 compounds.

In apparent contradiction of these results is the observed excretion of 60% of the 17-ketosteroid in the urine, following duodenal injection. This must however be viewed in the light of the very rapid further metabolism of 17-ketosteroids in the sheep to 17a- and 17b-OH steroids. Nevertheless this firmly establishes the presence of an active reabsorption mechanism operating in the intestinal tract of the sheep. Further, there is no indication that c-19 steroids are more prone to fecal excretion than are the c-21 corticosteroids. It remains to be established whether this is a result of 17-hydroxylation in the gut with the production of a more polar series of compounds which are more readily reabsorbed.

#### 4.6 In Vivo Metabolism of Cortisol in the Normal, Whole Sheep

The major pathway for the metabolism of cortisol in the sheep involves reduction of ring-A resulting in a total percentage of cortisol plus cortisone of only 3% of the total urinary cortisol metabolite (cf 1-2% in humans). This reduction is consistent with that found in the humans and contrasts with that found in the guinea pig.

The large percentage of cortols and cortolones present may imply a prior reduction of the c-20 ketone, with the formation of the ring-A unsaturated glycols found in human urine (de Courey *et al*, 1953a). However if these intermediates are present in sheep urine they cannot account for more than a few percent.

Of the c-21 fraction reduced completely in ring-A, about 50% has the dihydroxyacetone side-chain, the remainder being reduced at c-20 (glycols). The major c-21 tetrahydro metabolite is THF (11%) with only 3% of the 11-ketone (THE). (It is only rarely that the urinary excretion of THE exceeds that of THF). It

is worthy of note that the 11b-hydroxyl metabolites are predominant ( $F/E = 3$ ;  $THF/THE = 4$ ) which is the reverse of that found in the c-19 fraction. This high proportion of tetrahydro-dihydroxyacetone steroids is in contrast with the 1% found in bovine urine. The small amount of allo-THF found (1.6%) is in keeping with the small fraction of 5a- compounds found in sheep urine (about 15% of the total neutral extract has the 5a- configuration) but is somewhat less than the 7 - 15% of allo-THF found in the human.

The c-20 alcohols (cortols and cortolones) chromatographing with mobilities less than THF in the partition system, accounts for 18% of the total cortisol metabolite and this is consistent with the high proportion of glycols found in the bovine urine. The ratio of 11-keto to 11b-hydroxyl compounds (cortolone: cortols) is very nearly 0.5 in the sheep which contrasts markedly with the same ratio in humans of from 1.7 to 5 (Fukushima *et al*, 1960). Furthermore the ratio of (20)b-cortolone to (20)a-cortolone in the sheep is 7 to 1 which is in contrast to the ratio of 1:1 found in humans. The presence of a compound chromatographing slightly higher than THF, and another more polar than the cortols, is considered to be due to a metabolite with the 5a--3b-hydroxysteroid grouping. This configuration is generally more polar chromatographically than the other three combinations (5a-3a; 5b-3a; 5b-3b). Large amounts of cortisol metabolite with this configuration appears in canine urine (Gold, 1961).

The allo-cortols and allo-cortolones are obviously present but due to the small amounts present were not individually characterised, nevertheless they contribute significantly to the total glycol metabolite of the sheep. Relatively large amounts of 5a-isomer was found in the cortol fraction, but whether this is represented as 3b- or 3a-hydroxysteroid was not elucidated.

Small amounts of other c-21 metabolites were tentatively identified (chapter 2) but due to the small

quantities present, they must await further characterisation. In general the abundance of highly reduced cortisol metabolites found in the sheep is in keeping with that found in bovine urine, humans, and the dog. The separation of c-19 and c-21 cortisol metabolites showed only 45% of the total metabolites were c-21's. This contrasts with the situation in humans where the c-21 metabolites make up 70 - 80% of the total cortisol metabolite and in the cow (Watanabe, 1965) and dog (Gold, 1964) where the cortisol metabolite is almost exclusively c-21. This may however be explained by the enterohepatic recirculatory mechanism active in the sheep.

The cleavage of the side-chain of cortisol is well known (Burstein *et al.*, 1953a; Sandberg *et al.*, 1957), and appears to be very active in the sheep, although whether enzymes of the sheep or microbes of the gut are responsible for this side-chain removal remains to be established. Characterisation of the c-19 compounds appearing in the sheep urine presented considerable difficulty in view of the further reduction of the 17-ketone to 17a- and 17b-alcohols. Elucidation of the structure of c-19-6 and c-19-8 through infra-red and mass-spectrometry in combination with chemical alteration and analysis, was the basis for characterisation of the other seven 11-ketone-diols and triols present in the urinary neutral extract.

The principal c-19-metabolite found was 5b-A-3a, 17a-ol-11-one being 14% of the total metabolites excreted, with the 17b-OH isomer accounting for 10% of the total. This is in agreement with Lindner (1965) who found the neutral steroid 17a-ol-DHase activity in the sheep was 3 times that of the 17b-ol-DHase activity. Also in accordance with this finding is the ratio of 5b-A--17a-triol to -17b-triol of 5, in the romney ewe. Any discrepancy in the absolute ratio from that found by Lindner, is probably due to species differences.

The structure of c-19-7, given as 5a-A-3b, 17a-ol-11-one

is based on negative evidence and genuine determination of the structure must be the result of chemical or biosynthetic synthesis of the compound from a known starting material. There is also a conspicuous absence of some isomers and these are almost certainly inseparable from other metabolites in the chromatographic systems used.

The principal 17-ketosteroids have the 5b-configuration, and this is in agreement with the predominance of 5b-tetrahydro metabolites found in the c-21 fraction, and the 18% of radioactive metabolites found to be more polar than cortisone (mainly 17-ketosteroid) is in close agreement with the 10 - 15% of the total cortisol metabolite more polar than cortisone in the human (Fukushima, 1960). However in the human the 11-ketone and 11b-hydroxy etiocholanolones accounted for only 2 - 12%, compared to 12% (i.e. two thirds of the 17-ketosteroid fraction) in the sheep.

#### 4.7 In Vivo Metabolism of Cortisol in Surgically-Modified Sheep

##### 4.7.1 Metabolites Formed from I.V. Administration of 4-c<sup>14</sup>-C

The cortisol metabolite pattern found in the bile of a surgically-modified sheep was very different from that found in the urine of a whole sheep. The main biliary metabolites following I.V., 4-c<sup>14</sup>-cortisol were THF (31%), the cortols (21%) and the 17-ketosteroid group (20%). A considerable difference in the percentage of THF excreted in the bile (31%) to that found in the urine (15%) suggests some form of selective excretion or an unequal distribution of the catabolic enzymes involved in the reduction of ring-A. The latter seems more likely if the main site of ring-A reduction is located in the liver. A similar ratio for biliary/urinary distribution was also noted for c-21-A11, although the large amount of the very polar c-21-A1 (8%) found in the urinary excretion was not duplicated

in the bile. The percentage of cortols plus cortolones was similar in both excretion pathways.

The total c-19 fraction was only 25% of the total metabolites in both the IVB and IVU collections, compared to 55% in the urine of a whole sheep. Although the nature of the small quantity (5%) of 17-hydroxylated compounds present in the bile was not determined, the urine collected simultaneously with this bile was found to have only the 17b-hydroxyl isomers, which constituted 12% of the total radioactivity excreted by this route. This suggests that 17a-hydroxyl derivatives arise only via the enterohepatic circulation.

#### 4.7.2 Metabolites formed from Duodenal Infusion of 4-c<sup>14</sup>-cortisol Biliary Metabolites

A striking feature of the cortisol metabolite pattern of both the bile and the urine following intraduodenal infusion of the IVB-cortisol metabolites listed in table, 3-25, was the reduction in the percentage of both the side-chain glycols, and  $\alpha$ -ketols. This was associated with a large increase in c-19-steroid, suggesting side-chain cleavage of the c-21 metabolites during passage through the intestine. However, this is not conclusive proof that the reaction is confined to the lumen of the intestine: it may indicate a very active 17 $\alpha$ ,20-c<sub>21</sub>-desmolase located in the intestinal wall, the liver, or more specifically in the terminal area of the hepatic portal system. Argument for some side-chain cleavage in the liver stems from a comparison of the IVB : IFB and IVB : IFU ratios for THF (3:1, 3:1) and the cortols (3:1, 2:1) respectively. If there was no subsequent alteration of metabolites entering the hepatic portal system, the pattern shown in the bile and urine would be alike. However the further catabolism of the cortols shown in the biliary metabolites is not evident in the urine. Nevertheless most of the side-chain cleavage activity appears to be confined to some location preceding entry to the liver.

The importance of side-chain cleavage in the sheep is gauged from the percentage of c-19-metabolite found in the bile (89%) and urine (61%). The biliary metabolites constituted 19% of 17-KS, and 50% 17-OH-c-19, and was further divided into 22% 11b-OH-steroid and 28% 11-ketone-steroid. As a result of specific investigation it was concluded that only the 17a-OH-c-19 metabolite was present in the bile.

The urine on the other hand, contained both the 17a-OH and 17b-OH metabolites, constituting 39% of the total radioactivity found in this excretion.

#### 4.7.3 Summary

The overall distribution of radioactivity among the cortisol metabolites in each of the four collections (IVB, IVU, IFB, IFU) must be combined with the information from table, 3-24, to form an overall picture of the individual metabolite distribution via the two routes of excretion involved. However some general observations are listed:-

(1) The sheep contains a very active 5b-4,5-cne-hydrogenase (reductase) which was found to be 7 - 8 times more active than the 5a- reductase. The reduction of the 3-ketone resulted in a predominance of the 5b--3a-ol configuration but the presence of a less active (5a) 3b-hydroxysteroid dehydrogenase was indicated.

(2) An active 17a,20-c<sub>21</sub>-desmolase is present in the sheep as shown by the 25% c-19 contribution to the IVB and IVU excretions.

(3) Reduction at c-20 with a c-20-dehydrogenase contributes up to 25% of the total IVB and IVU metabolites. The possibility of a more active 20b-OH-dehydrogenase must be considered in view of the 7:1 ratio of b-cortolone to a-cortolone.

(4) The sheep was shown to have a very active

c-19-11b-hydroxysteroid dehydrogenase. The ratio of c-19-11b-OH steroid to c-19-11-keto steroid of 1:1 in IVB, IVU and IFB conforms to the equilibrium ratio of the 11b-hydroxysteroid dehydrogenase in other animals (Bush and Willoughby, 1957). However the 11-alcohol : 11-ketone ratio was 1:1.5 in the IFU collection and was further increased to 1:3.5 in the urinary excretion of a whole sheep. In contrast the ratio of THE :THE of 3:1 remained constant in the collections studied from both surgically-modified, and whole sheep.

This suggests a specific c-19-11b-hydroxysteroid dehydrogenase in the sheep capable of catalysing a hydrogen exchange at  $c_{11}$  in ring-A reduced steroids (see, Savard and Goldfaden, 1954)

(5) Relatively large quantities of 17a- and 17b-hydroxylated c-19 cortisol metabolites were found in the sheep. Furthermore the appearance of the 17a-OH derivative as the exclusive isomer in the bile suggests an absence of a 17b-OH-N-dehydrogenase in the liver; or the less likely selective excretion of the 17a-alcohol in the bile. That the 17a-OH-N-dehydrogenase is the only 17-hydroxylating enzyme in the liver does not preclude the possibility of the 17a-enzyme being found in the ovine erythrocytes, together with the 17b-enzyme as claimed by Lindner (1965).

The physiological role of the 17-hydroxylating enzymes is unclear but Lindner has suggested they may constitute a detoxification mechanism as a barrier to enterohepatic recirculation of biologically active corticosteroid. That these metabolites are confined to the fraction that has undergone enterohepatic recirculation (Lindner, 1965) is a contradiction of the finding in the present investigation of 5% and 12% 17-hydroxylated c-19-metabolites in the IVB and IVU collections respectively (table, 3-25). The finding by Wyngaarden (1955), of a 17a-OH-N-dehydrogenase in guinea pig liver supports the concept that 17-

hydroxylation may be confined to animals exhibiting an enterohepatic circulation of cortisol metabolites.

#### 4.2 Methods for the Colorimetric Estimation of Corticosteroids

Methods employed for the determination of corticosteroids in urine are based on colour reactions with certain groups in the corticosteroid molecule. Most have a sufficiently high degree of specificity to forego any elaborate procedures for the isolation of the chromogen before quantitation. Nevertheless the final accuracy of estimation of the chromogen in question may partly depend on the means of hydrolysis, extraction and purification.

Further complications arise in the treatment of ruminant urine, from the presence of ionones in often considerable quantities. These are probably carotenoid derivatives and have the property of behaving in a similar manner to corticosteroids and are strongly 17-ketosteroid positive (Holtz, 1954).

In the sheep urine a compound with a similar mobility to THE in the Kieselghur system (2.7.2.1a) was found to be strongly reactive with blue tetrazolium. From mass spectral data the compound was shown to be non-steroidal, and was separable from the c-21 steroids by florisil column fractionation whereby it was eluted with the c-19 fraction.

In view of the presence of these two, and probably more, groups of interfering chromogens, it was decided to attempt a degree of purification of the 17-OH-CS group before application of the colour reactions. This was achieved by using mild enzyme hydrolysis of the corticosteroid conjugate present in the urine, followed by the removal of both groups of interfering compounds mentioned above, through application of the neutral steroid extract to a florisil column. This first step was sufficient to remove the major part of 'reducing chromogen' interference from the c-21

fraction for a-ketol determination, and considerably reduced the discolouration in the 17-ketosteroid determination. The principal interference in the 17-ketosteroid determination came from a substance whose concentration paralleled that of the 17-OH-CS, and caused browning and decreased sensitivity of the Zimmerman reaction. This was overcome by using the correction equation and also by using an 'internal standard' of added 17-KS, to determine the decrease in sensitivity in each assay.

Methods used for the chemical assay of presumed adrenocortical metabolites in ruminant urine were first based on the Zimmerman reaction applied directly to the urine extract. Whitten(1943) reported the use of this reaction on the urine of pregnant ewes, and on ram urine (Ruliffson *et al*, 1954). Holme and Firch(1955) found low and variable values for 17-OH-CS in cattle urine with the Porter Silber reaction, following enzyme hydrolysis. This absence of 17-OH-CS in ruminant urine was confirmed by Holcombe(1957), although Watanabe(1965) found 22% of cortisol metabolites in the cow were of the dihydroxyacetone type (although only 1.5% were reduced in ring-A). In this case Watanabe used the Norymberski(1956) method for side-chain cleavage followed by separation of the 11-hydroxy-ketosteroid on an alumina column and further purification was by partition paper chromatography. He reported that ketosteroids were measured by the Zimmerman reaction without interference from the ionone derivatives. Holcombe (1957) also found that the Norymberski method when applied to the urine of an adrenalectomised bull, with and without cortisone substitution therapy, gave the greatest contrast of 17-OH-CS. Direct assay of 17-KS with the Zimmerman reaction, and both the total extract and the ketonic fraction with the blue tetrazolium reaction, gave high values with and without administered cortisone. This is probably due to interference from ionones and reducing substances

similar to those found in sheep urine.

#### 4.9 Colorimetric Estimation of 17-OH-CS

##### 4.9.1 Blue tetrazolium reaction

Steroids found in the urine of mammals that have been derived from cortisol and have retained the side-chain, also retain the 17 $\alpha$ -alcohol group. This allows division into two groups based on the side-chain properties:-

- (1) those that have the c-20-ketone intact ('dihydroxyacetone')
- (2) those that are reduced at the c-20 position ('glycol')

Only the former group (1) has the ability to display the reducing properties characteristic of an alpha-ketol configuration, and react with blue tetrazolium. The glycol side-chain is incapable of any colour reaction with blue tetrazolium in the cold.

Izzo et al (1957) have studied the reducing character of other steroid functions towards the blue tetrazolium reagent; and have found the  $\alpha$ -ketol group most effective. The -4-ene- $\beta$ -one grouping gave a formazan, but the rate and intensity of colour formation was dependent on the location and configuration of other functional groups in the molecule.

In alkaline medium, reducing steroids give an intense blue diformazan from the yellow ditetrazolium chloride. The choice of alkali must be considered to be somewhat dependent on the sensitivity of the prepared reagent, and the storage property that is required. Sodium hydroxide is the most commonly used alkali; both aqueous and alcoholic (Recknagel and Litteria, 1956). The use of aqueous alkali has the advantage of better keeping properties but the sensitivity of the prepared reagent was found to be much reduced. Tetramethyl-ammoniumhydroxide (TMAH) has been used (Mader and Buck, 1952) and was the preferred reagent in this study due to its superior keeping qualities, compared to those

of alcoholic NaOH. The sensitivity obtainable from using TMAH was found equal to that obtained when using sodium hydroxide.

The reagent when prepared, is usually stable for only a short period (Burton et al, 1951). However in this investigation, absolute ethanol was distilled off  $\text{NaBH}_4$  and subsequently redistilled several times. This treatment combined with the use of TMAH as the alkali, allowed the prepared reagent to be kept in the refrigerator for several months.

The type of alcohol used affected the sensitivity of the reagent. Methanol, although having less chromogenic material present, was found to produce a much less sensitive reagent. Ultimate sensitivity of the blue tetrazolium reagent prepared with ethanol and TMAH was 1 - 5 ug of THF in a 3 ml. cuvette.

#### 4.9.2 Zimmerman reaction

The urine KS fraction consists of neutral and phenolic 17-KS and the phenolics (estrogens) are removed from the urinary extract by an alkali wash at an early stage.

The colorimetric method most widely used is based on the reaction discovered by von Bitto (1892) and adapted to steroid ketones by Zimmerman. The reaction depends on the development of a red-purple colour (max. abs. 520 mu.) when steroids containing the  $-\text{CH}_2-\text{CO}-$  group react with alkaline mDNB. Steroid ketones other than at the 17 position give much less colour with the reagent and the absorption maximum is not at 520 mu.

Most methods have in common the incubation of the 17-KS with strongly alkaline mDNB in the dark at a fixed temperature. From a series of incubations at temperatures from  $15^\circ\text{C}$  to  $40^\circ\text{C}$  the optimum temperature was found to be in the region of  $25^\circ - 30^\circ\text{C}$ . Higher temperatures gave more intense browning and less colour at 520 mu., while at the colder temperatures the

colour was prone to fading over the time of incubation required (up to 2 hours).

Whereas the concentration of mDNB is not so critical (apart from its solubility in the solvent used) the type and concentration of alkali used has been the basis for much experimentation. Callow(1938) used 0.83 N KOH in absolute alcohol while Holtorff and Koch(1940) used 1.67N KOH in 50% alcohol. Organic alkalis such as benzyl trimethyl  $\text{NH}_4^+$  methoxide and the TMAH used in this study have been used more recently. The former base was recommended by Bongiovanni et al(1957) who compared this reagent with that prepared from alcoholic and aqueous 2.5N KOH. Advantages were listed as

- (1) lower reagent blank
- (2) 100% more colour than inorganic alkali
- (3) less colour fading
- (4) the dichloromethane extraction of the incubation mixture remains clear rather than opalescent.

These last two points bear further expansion. When using TMAH in this study the degree of opalescence (found to be due to water in the  $\text{CH}_2\text{Cl}_2$ ) was dependent on the temperature and length of time shaken and was more than often absent completely. When present the cloudiness was cleared by the addition of anhydrous sodium sulphate and this was finally included as part of the standard procedure. Fading was found to commence only after one hour from the start of the reaction.

Urine hydrolysed with  $\beta$ -glucuronidase may contain large quantities of steroids with c-3, c-11, c-20 ketones. These along with other non-ketonic material causes browning with absorption in the region 420 - 440 mu. Some allowance can be made by application of a colour correction equation such as used by Allen(1950) or that proposed by Talbot et al(1942) which computes the final optical density reading from readings taken at 520 and 430 mu.

Further reduction in blank value and browning was achieved by distilling the alcohol used for the

reagent several times, after refluxing with the reagent chemicals. This was found to be more satisfactory than the method of Callow et al(1938) or using silver nitrate in the same way.

#### 4.10 Cortisol Production Rate in the Sheep

Cortisol production rate was calculated from the colorimetric determination of both a-ketols, and 17-ketogenic (all c-21 cortisol metabolites) steroids present as urinary neutral steroid.

##### (1) From a-ketol determination -

The addition of the total a-ketol in each of the 24 one-hourly collections (section, 3.9) gave a total of 45 mgm excreted over the period of collection (18 days) (fig.3.7). The metabolism of 4-c<sup>14</sup>-F in the sheep resulted in the urinary excretion of 25% (table, 3-18) of the radioactivity as a-ketol. Application of this percentage to the daily excretion of a-ketol, gave a daily cortisol excretion rate of 10 mgm in the sheep studied.

##### (2) From 17-ketogenic steroid -

By a similar calculation to that in (1), the total 17-ketogenic steroid recovered was 88 mgm (fig.3.8), this being 45% of the total urinary cortisol metabolites. This gives a daily cortisol excretion of 10.5 mgm in the sheep studied.

The good agreement between these two cortisol production values is an indication of the reliability of this method for the estimation of 17-OH-CS in sheep urine. Further, the value obtained is consistent with the range of 3 - 15 mgm / day reported by Coghlan et al(1966) and Paterson and Harrison(1967), but somewhat less than the value of 12 ug/minute (18 mgm/day) in a 45 Kg sheep given by Tait and Burstein(1964) for the clearance of cortisol from the plasma.

#### 4.11 Diurnal Variations of Corticosteroid Metabolites in Sheep Urine

It has become generally accepted that rhythmic excretion of steroid chromogens in the urine of mammals has a maximum in mid-morning (about 8 a.m.) and low levels at night. But as early as 1943 (Pincus, 1943), "intermediate afternoon values" were reported in urinary ketosteroid excretion. With shorter collection periods (2 hourly - Vestergaard and Leverett, 1957) higher resolution was obtained and in 200 collections, Vestergaard and Leverett claimed 197 showed a double wave character. Halberg (1953) also noted a secondary afternoon maximum with 17-ketosteroid excretion in humans. The seminocturnal habits of sheep should be kept in mind when comparing the amplitudes of the biphasic diurnal excretory patterns of humans and sheep.

The excretion of both  $\alpha$ -ketolic and 17-ketosteroidogenic material in the urine of a romney ewe was shown to follow a pattern with maxima in the late morning and evening (see fig. 4-1). This is consistent with the observation of Mixner *et al* (1957) who have reported diurnal variations of urinary ketonic chromogens in the cow - table, 4-1.

table 4-1

Diurnal excretion of ketonic chromogen in the cow

Breed of Cow	Period of collection (time of day in hours)		
	12p.m.-3a.m.	3a.m.-4p.m.	4p.m.-12p.m.
Guernsey	22	48	30
Holstein	25	45	30

(figures given as % of total 24 hour excretions, measured as ketonic chromogen)

A similar observation of ruminant steroid excretion was made by Holcombe (1957), who detected a diurnal variation of urinary "reducing corticoids" in both rams and bulls (see fig. 4.2) using three-hourly urine collections over 13 days.

The presence of two diurnal excretion maxima is evident in the levels of both  $\alpha$ -ketolic and 17-ketosteroidogenic steroids in the romney ewe urine

(see fig.4-1). Holcombe has also reported the presence of a biphasic excretion pattern in both the ram and bull urinary reducing corticoids. The reason for the two maxima is obscure. Holcombe suggested the reason might lie in disturbance of the sheep during the 6.30a.m. and 1.30p.m. feeding and cleaning of the stalls. This would not explain the biphasic effect shown in this study as the sheep was kept under natural daylight conditions and fed once daily at 10 a.m.

The two stimuli may result from the dual light-change stimuli of "dawn and dusk", which synchronise a variety of metabolic events in lower life forms. On the other hand,

(1) if the feedback of corticoids on the release of ACTH from the pituitary were delayed for any reason, this could have the effect of "frequency doubling" the normal oscillation of the adrenal cortical function and giving the double maximum phenomenon

(2) or it may be that the dynamics of the hypothalamic-adeno-hypophyseal-adrenocortical axis with its inherent feedback control, are such that a single daily stimulus to cortisol secretion results in a rebound phenomenon to give the second maximum.

In support of this latter view a biphasic system in response to exogenous ACTH has been demonstrated. A sharp depression of ACTH secretion, resulting from either inhibition of ACTH release directly, or via a neural mechanism, followed the first high plasma-ACTH concentration and reached a minimum after 6 - 12 hours (Henkin and Knigge, 1963).

The urine volume output from the sheep also followed a biphasic rhythm in spite of the single daily feed. The variation of urine volume in sympathy with 17-OH-CS excretion has been reported (Forsham et al, 1955). The maxima appeared at 9.30 a.m. and midnight, thus following the excretion pattern of corticosteroids reduced at c-20 (vide infra).

The maxima for the urinary excretion of a-ketols

are between 7 a.m. and 8 a.m., and between 7 p.m. and 9 p.m. (see fig.4-1). The two maxima for 17-ketogenic steroids occur between 8 a.m. and 10 a.m. and from 11 p.m. to 12 p.m. (see fig.4-1).

The cortisol metabolite  $\alpha$ -ketols are those with the -17 $\alpha$ ,21-ol-20-one side-chain configuration and include cortisone, cortisol THE, THF and other ring-A isomers of THE and THF. In the sheep the predominant urinary  $\alpha$ -ketols are the ring-A reduced metabolites, and in particular THEF. Cortisone, cortisol and other ring-A unsaturated metabolites of cortisol are of minor importance only, in the sheep (see chapter 3). It must be assumed that any interference from corticosterone metabolites that may have the  $\alpha$ -ketol group intact is insignificant, in view of the secretion from the sheep adrenal of only small amounts of this corticosteroid (Bush and Ferguson, 1953).

The 17-ketogenic steroids are those with the -17 $\alpha$ , 20,21-ol or -17 $\alpha$ ,21-ol-20-one configuration. This encompasses all the c-21 cortisol metabolites found in the sheep urine. The difference therefore, between the diurnal urinary excretion pattern of  $\alpha$ -ketolic steroids, and that of 17-ketogenic steroids must be that contributed by the very polar corticosteroids with the glycol side-chain. The difference is shown graphically in fig.4-1. The conclusion to be drawn from this observation is that the cortisol metabolites that have been reduced at c-20 reach an excretion maximum some time after the maximum for the excretion of those steroids with the c-20 ketone intact. The delay in reaching the mid-morning maximum is about 90 minutes, and the delay in the evening is about 3.5 hours.

This time difference in the excretion of cortisol metabolites, differing in the degree of reduction, has not previously been reported. The urinary ketosteroid levels are known to follow closely the levels of ketosteroid in the plasma (Sandberg et al, 1953),

Fig 4.2

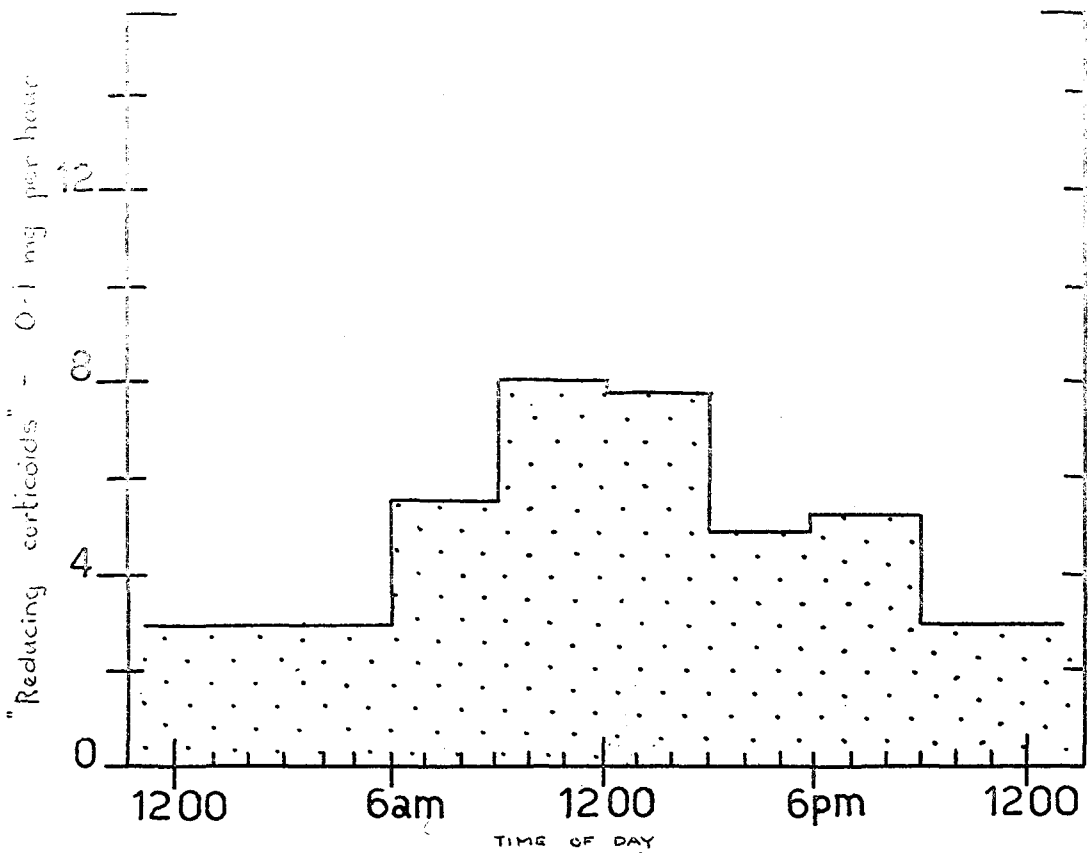
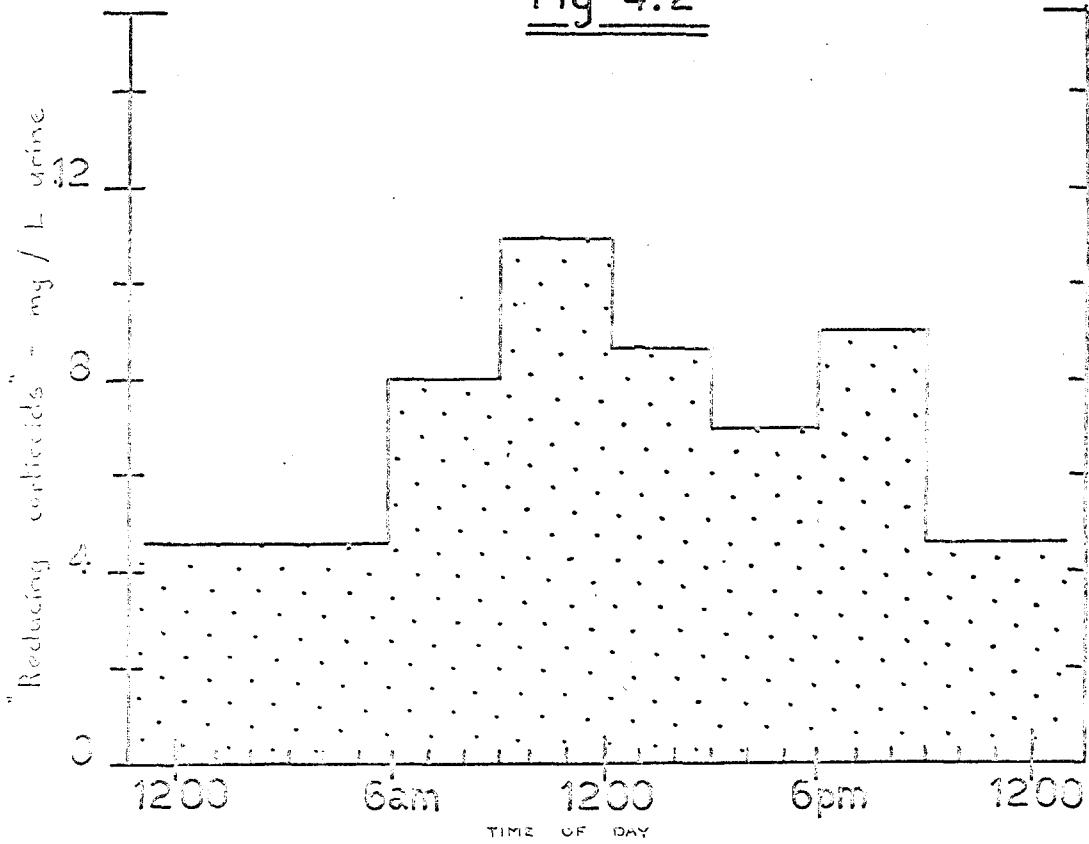

Diurnal variations in the excretion of "Reducing corticoids", in the ram.

Fig 4.1

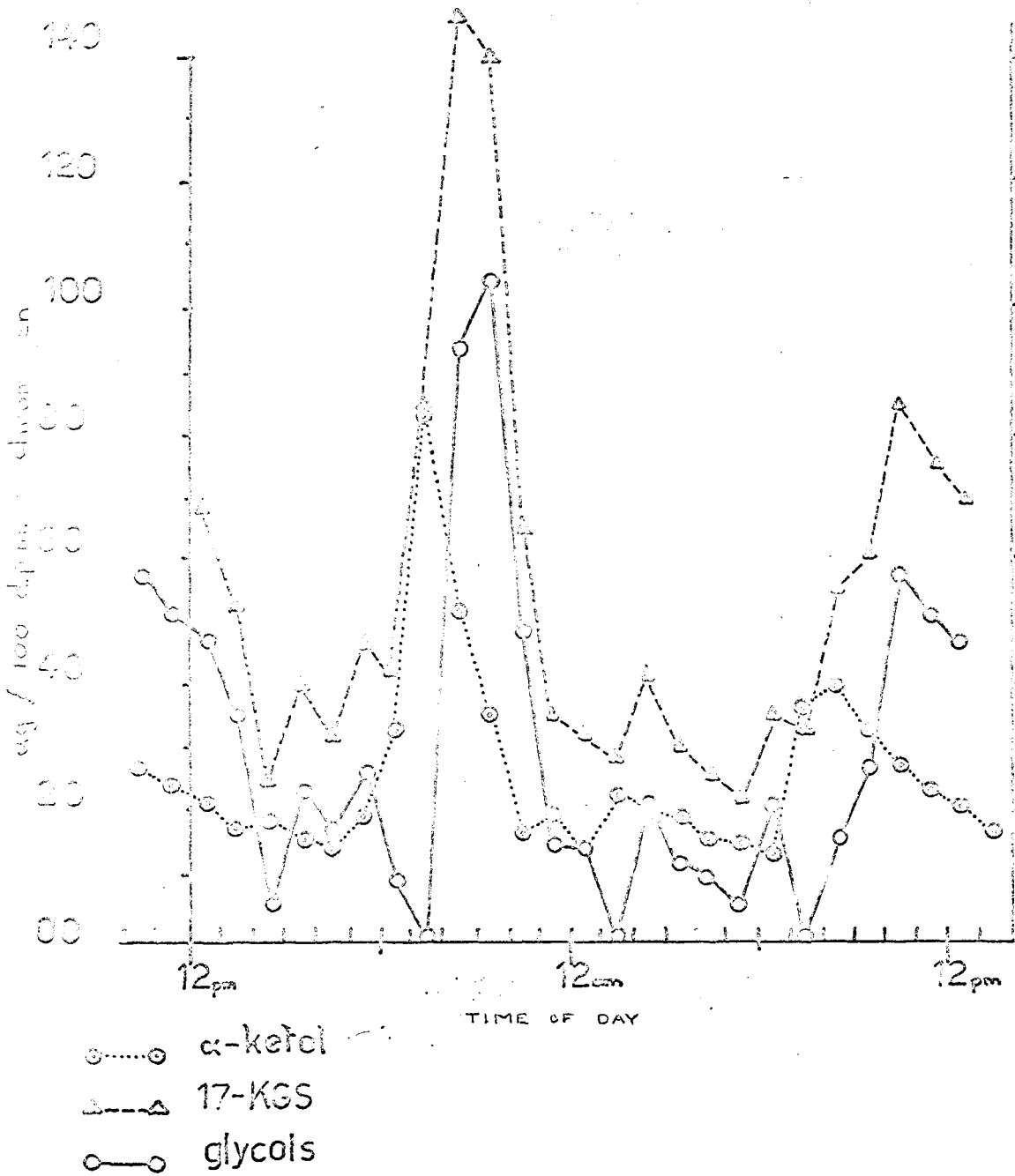

Differences in the rate of excretion of  $\alpha$ -ketol and 17-ketogenic steroid in the sheep

although Doe et al(1954) has reported a 2 hour delay in the urinary excretion maximum of ketosteroids, from the maximum ketosteroid level in the plasma. Further, Fincus et al(1948) reported diurnal variation in both human ketosteroid and neutral reducing lipid in the urine, but found factors affecting urinary ketosteroid fluctuations were not the same as those evoking changes in the rate of neutral reducing lipid excretion. Sandberg et al(1955) also reported differences in the excretion of 17-ketosteroid and 17-OH-CS glucuronides. In this light it is not difficult to suppose that the rate of excretion of plasma corticosteroids and perhaps neutral lipid in general, is dependent on some characteristic such as polarity of the molecule as a whole, so affecting its solubility in water. The ease of conjugation, nature of the conjugated molecule or differences in binding affinity with plasma protein may possibly contribute to these observed differences in excretion rates.

It may be not unreasonable to speculate that this variation in the rate of excretion of cortisol metabolites, dependent on the degree of reduction of the molecule, could influence the rate of metabolism of cortisol and even its secretion from the adrenal (see chapter 1). These avenues of thought must remain the basis for further investigation both into the general metabolism of cortisol in the sheep and the excretion characteristics of the metabolites so formed.

--- /--/ ---

SUMMARY

1. A method for the purification of paua (Haliotis iris) stomach b-glucuronidase using methanol was presented and the activity of this preparation towards corticosteroid conjugates was investigated. The enzyme activity towards conjugates dissolved in urine was found to be no different to the activity shown towards conjugates extracted from urine and redissolved in buffer.
2. A b-glucuronidase preparation from limpet (Notoacmea & Cellana) was compared with the paua preparation in respect of affinity for the corticosteroid conjugate, under the same conditions and with the same concentration of enzyme present (assayed as Fishman units). The limpet enzyme was shown to be slightly more active but not advantageously so.
3. A continuous elution partition system for the separation of the cortolones isomeric about c-20 and many of the cortol isomers, was developed as an extension of a system suitable for separation of compound THE through to cortisone.
4. A thin layer partition system was developed for the rapid separation of 17-ketosteroids with a single development, and was found to be quite suitable for the separation of the five neutral 17-ketosteroids isolated from sheep urine.
5. The crude extract of urinary corticosteroid after hydrolysis was divided into c-19 (55%) and c-21 (45%) fractions using a florisil column, and further separation using thin layer techniques resulted in the detection of 14 c-19 metabolites and 23 c-21 metabolites, or groups of metabolites.
6. The principal c-19 compounds were 5b-A-3a,17a-ol-11-one and 5b-A-3a,17b-ol-11-one with 5a-A- and 5b-A- compounds isomeric about the c-3-alcohol and the c-17-OH also detected. A compound identified as 5a-A-3b,17a-ol-11-one and its -11b-ol-isomer, were also described. The 17-ketosteroid (mainly 5b-A-3a-ol-11,17-one) was  $\frac{1}{2}$  of the

c-19 fraction, and the 11-ketone steroids comprised 80% of the c-19 fraction.

7. The ratio of c-21 steroid with the dihydroxyacetone side chain grouping, to c-21 steroid with the glycol side chain, was 1:1. The principal a-ketol was THF with the 11-ketone and 11b-OH glycols present in about equal amounts. An unusually high ratio of b-cortolone to the a-cortolone ( 7:1 ) was noted.

8. Experiments conducted on surgically modified sheep uncovered an active enterohepatic recirculation mechanism (a) about 60% of the I.V. injected 4-c<sup>14</sup>-F was excreted in the bile with a high proportion (80%) of c-21 metabolites, the principal steroid being THF (31%). The urinary excretion pattern was similar but with only half the percentage of THF to that found in the bile, ie. only 20% of the THF formed from cortisol is excreted in the urine in the first cycle

(b) biliary 4-c<sup>14</sup>-F-metabolites infused into the duodenum were almost completely recovered in the bile and urine, mainly as c-19 steroid (70%). A division of 17a- and 17b-hydroxylation enzymes is suggested from the virtual absence of 17b-hydroxy-c-19-steroid in the bile. The urine was shown to contain both 17a- and 17b-hydroxy-c-19-steroid

(c) the mechanism of reabsorption of steroid from the lumen of the intestine was found to be equally as active towards c<sup>14</sup>-17-ketosteroid as the biliary metabolites in general, and was recovered in the urine as 17-OH-steroid.

9. A new method for the quantitation of urinary cortisol metabolites of the sheep was developed, involving a preliminary fractionation of the corticosteroid using a florisil column. the cortisol production rate estimated by quantitation of both a-ketol and 17-ketogenic steroid was 10 mgm / day, in both cases.

10. A diurnal rhythm in the urinary excretion of cortisol metabolites was found to exhibit a pronounced biphasic character.

11. A difference in the rate of excretion of the two

classes of steroid assayed was apparent. This difference dependent on the degree of reduction of the side chain has not been reported in the literature, and possible implications are discussed.

--- / - / ---

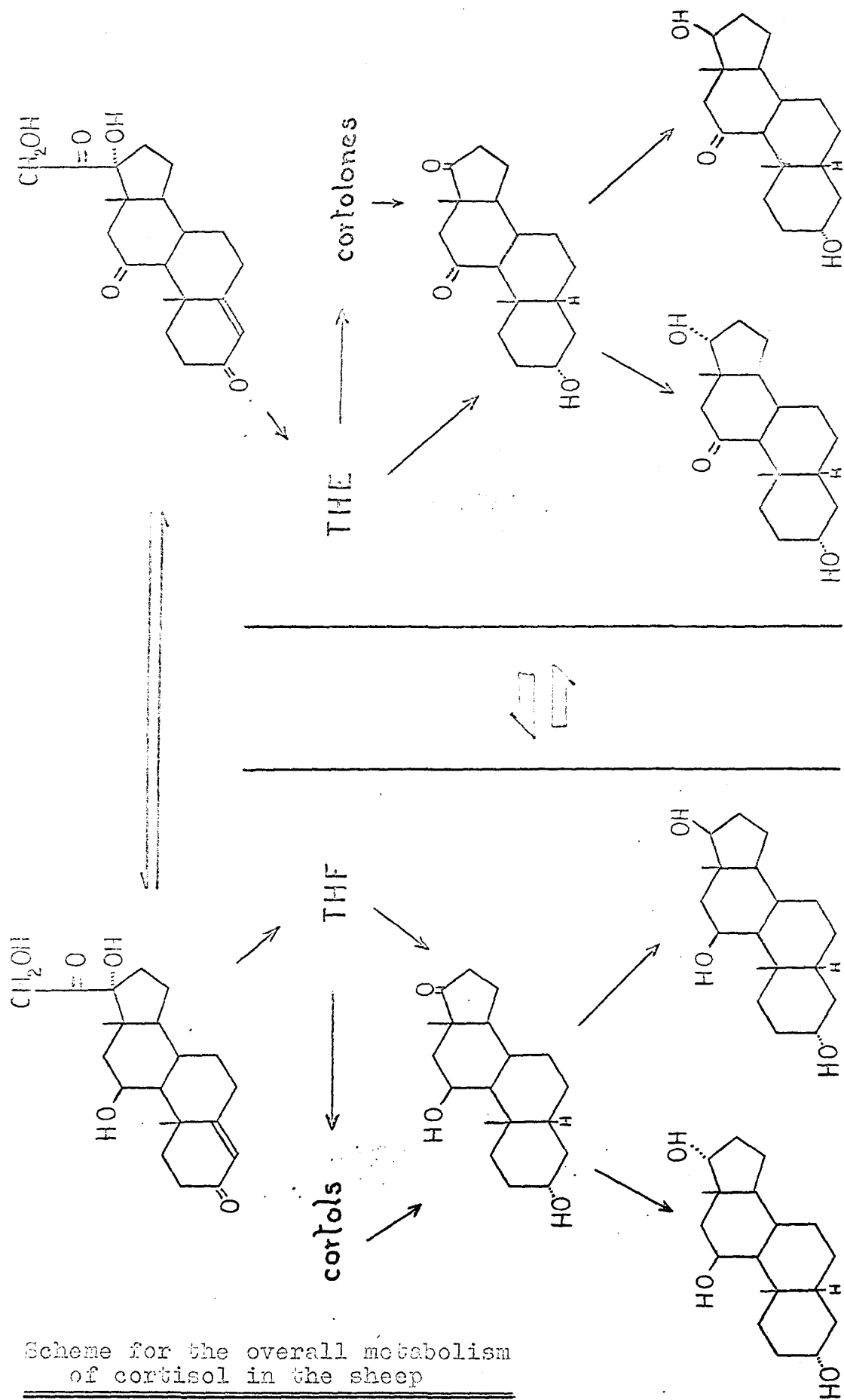

Scheme for the overall metabolism of cortisol in the sheep

LITERATURE CITED

- Agarwal, K.N., and Garby, L. (1964)  
Acta. Endocrin., Suppl. 93, 3
- Andersen, R.H., and Egdahl, R.H. (1964)  
Endocrin., 74, 538
- Antoniades, H.R., Pennell, R.B., Slaunwhite, W.R. (1957)  
J. Biol. Chem., 229, 1071
- Appleby, J.I., Gibson, G., Worymberski, J.K., Stubbs, R.D.  
(1955)  
Biochem. J., 60, 453
- Ashmore, J., Hastings, A.B., Nesbett, F.E., Renold, A.E.  
(1956)  
J. Biol. Chem., 218, 77
- Ashmore, J., Stricker, S., Love, W.C., Filscheimer, G. (1961)  
Endocrin., 68, 399
- Ashmore, J., Cahill, G.F., Hillman, R., Renold, A.E. (1958)  
Endocrin., 62, 624
- Axelrod, L.R., and Miller, L.L. (1956)  
Arch. Biochem. Biophys., 60, 373
- Axelrod, L.R., Miller, L.L., Herling, S. (1956a)  
J. Biol. Chem., 219, 455
- Axelrod, L.R., and Goldzieher, J.W. (1960)  
J. Clin. Endocrin. Metab., 10, 238
- Bass, A.D., Chambers, J.W., Richtarik, A.A. (1963)  
Life Sciences, 4, 265
- Bassett, J.M., (1963)  
J. Endocrin., 26, 339
- Bate-Smith, E.C., and Westall, R.G. (1950)  
Biochim. Biophys. Acta., 4, 427
- Baulieu, E.E., and Dray, F. (1963)  
J. Clin. Endocrin. Metab., 23, 1298
- Beisel, W.R., Di Raimondo, V.C., Forsham, P.H. (1964)  
Ann. Intern. Med., 60, 641
- Berliner, D.L., and Wiest, W.G., (1956)  
J. Biol. Chem., 221, 449
- Berliner, D.L., and Dougherty, T.F. (1958)  
Fed. Proc., 17, 189
- Berliner, D.L., Grosser, B.I., Dougherty, T.F. (1958)  
Arch. Biochem. Biophys., 77, 81
- Berson, S.A., and Yalow, R.S. (1952)  
J. Clin. Endocrin. Metab., 12, 407
- Birke, G., and Plantin, L.O. (1954)  
Acta. Med. Scand., Suppl. 291, pp95
- Bischoff, F., and Katherman, R.E. (1948)  
Amer. J. Physiol., 152, 189

- Bledsoe, T., Island, D.P., Ney, R.L., Liddle, G.W. (1964)  
J. Clin. Endocrin. Metab., 24, 1303
- Bloch, E., Dorfman, R.I., Pincus, G. (1954)  
Proc. Soc. Exp. Biol., 85, 106
- Bondy, P.L., Ingle, D.J., Weeks, R.C. (1954)  
Endocrin., 55, 354
- Bongiovanni, A.M., Eisenmenger, W.J. (1951)  
J. Clin. Endocrin. Metab., 11, 152
- Bradlow, H.L., Dobriner, K., Gallagher, T.F. (1954)  
Endocrin., 54, 311
- Bradlow, H.L., Dobriner, K., Gallagher, T.F. (1954a)  
Endocrin., 54, 343
- Bradlow, H.L., Hellman, L., Zumoff, B., Gallagher, T.F. (1956)  
Science, 124, 1206
- Bradlow, H.L., Mukushima, D.K., Zumoff, B., Hellman, L.,  
Gallagher, T.F. (1962)  
J. Clin. Endocrin. Metab., 22, 748
- Brady, R.O., Lukens, F.W.D., Gurin, S. (1951)  
J. Biol. Chem., 193, 459
- Erodish, A., and Long, C.W.H. (1960)  
Endocrin., 66, 149
- Bransome, E.P., and Chargaff, E. (1964)  
Biochim. Biophys. Acta., 91, 180
- Bray, B.M., Merivale, W.H.H. (1953)  
J. Endocrin., 9, 1
- Brown, H., Englert, E., Wallach, S. (1963)  
Rec. Prog. Horm. Res., 18, 167
- Erunelli, B., (1934)  
Arch. Intern. Pharmacodynamie, 49, 262
- Burstein, S. (1956)  
J. Amer. Chem. Soc., 78, 1789
- Burstein, S., and Dorfman, R.I., (1955)  
J. Biol. Chem., 213, 581
- Burstein, S., and Kimball, H.L., (1963)  
Steroids, 2, 209
- Burstein, S., Dorfman, R.I., Nadel, E.F. (1954)  
Arch. Biochem. Biophys., 53, 307
- Burstein, S., Savard, K., Dorfman, R.I. (1953)  
Endocrin., 52, 448
- Burstein, S., Savard, K., Dorfman, R.I. (1953a)  
Endocrin., 53, 88
- Burton, R.B., Keutmann, E.H., Waterhouse, C. (1953)  
J. Clin. Endocrin. Metab., 13, 48
- Burton, R.B., Zaffaroni, A., Keutman, E.H. (1951)  
J. Biol. Chem., 188, 763
- Bush, I.E. (1953)  
J. Endocrin., 9, 95

- Bush, I.E. (1961)  
The Chromatography of Steroids (Pergamon)
- Bush, I.E., and Ferguson, E.A. (1953)  
J. Endocrin., 10, 1
- Bush, I.E., and Mahesh, V.B., (1957)  
Biochem. J., 71, 689
- Bush, I.E., and Willoughby, H., (1957)  
Biochem. J., 57, 689
- Bush, I.E., and Mahesh, V.B., (1959)  
Biochem. J., 71, 705
- Bush, I.E., and Mahesh, V.B. (1959a)  
Biochem. J., 71, 718
- Butruk, E., and Vaedtke, J., (1968)  
J. Chromatog., 32, 511
- Butt, W.R., Herly, A.A., Morris, C.F.C.R. (1948)  
Biochem. J., 42, 1117
- Callow, H.H., Callow, E.H., Emmens, C.W. (1938)  
Biochem. J., 32, 1312
- Callow, R.H., and Young, F.G., (1936)  
Proc. Royal Soc., (Lond.) 157, 194
- Calvin, H.I., and Lieberman, S. (1964)  
Biochemistry 3, 259
- Capsi, E., and Rechter, O. (1956)  
Arch. Biochem. Biophys., 51, 299
- Chaikin, S.W., and Brown, H.G. (1949)  
J. Amer. Chem. Soc., 71, 122
- Chang, E. (1964)  
Steroids, 4, 237
- Charney, W., and Herzog, E.L., (1967)  
Microbial Transformation of Steroids.
- Chart, J.J., Hetzel, M., Gaunt, R. (1956)  
Proc. Soc. Exp. Biol., 91, 73
- Chen, P.S., Mills, I.H., Bartter, F.C. (1961)  
J. Endocrin., 23, 129
- Clark, I. (1953)  
J. Biol. Chem., 200, 69
- Clark, D.C., and Kochakian, C.D., (1947)  
J. Biol. Chem., 170, 23
- Coghlan, J.P., Wintour, M., Scoggins, B.A. (1966)  
Aust. J. Exp. Biol. Med. Sci., 44, 639
- Cohen, M., Stiefel, H., Reddy, W.J., Laidlaw, J.C. (1958)  
J. Clin. Endocrin. Metab., 18, 1076
- Cohen, S.L., (1951)  
J. Biol. Chem., 192, 147
- Cohen, S.L., and Marrian, G.F. (1934)  
Biochem. J., 28, 1603

- Cohen, S.L., Marrian, G.F., Odell, A.D. (1936)  
Biochem. J., 30, 2250
- Cohn, G.L., and Pancake, E. (1964)  
Nature, 201, 75
- Cohn, G.L., Upton, V., Bondy, P.R. (1961)  
J. Clin. Endocrin. Metab., 21, 1328
- Courcy de, C., Bush, I.E., Gray, C.H., Lunnou, J.B. (1953)  
J. Endocrin., 9, 401
- Crepy, O., Jayle, M.F., Meslin, F.R. (1957)  
Acta. Endocrin., 24, 233
- Daughaday, W.E., (1956)  
J. Clin. Investig., 35, 1428
- Daughaday, W.H. (1958)  
J. Clin. Investig., 37, 519
- Doe, R.P., Fernandez, R., Seal, U.S. (1964)  
J. Clin. Endocrin. Metab., 24, 1029
- Doe, R.P., Flink, E.B., Flint, H.G. (1954)  
J. Clin. Endocrin. Metab., 14, 774
- Dorfman, R.I. (1954)  
Rec. Prog. Horm. Res., 9, 5
- Dorfman, R.I. (1954a)  
J. Clin. Endocrin. Metab., 14, 318
- Dorfman, R.I., Wise, J.E., Shipley, R.A. (1950)  
Endocrin., 46, 127
- Eades, C.H., Pollack, R.L., King, J.S. (1954)  
Fed. Proc., 13, 201
- Edwards, R.W.H., Kellie, A.E., Wade, A.P. (1953)  
Mem. Soc. Endocrin., 2, 53
- Eik-Nes, K.B., and Hall, P.F. (1965)  
Vit. & Horm., 23, 153
- Eik-Nes, K.B., Nelson, D.H., Samuels, L.T. (1953)  
J. Clin. Endocrin. Metab., 13, 1280
- Eik-Nes, K.B., Schellman, J.A., Lumry, R., Samuels, L.T.  
(1954)  
J. Biol. Chem., 206, 411
- Eisenstein, A.B. (1960)  
Endocrin., 67, 97
- Eisenstein, A.B., Berg, E., Goldenberg, D., Jensen, B. (1964)  
Endocrin., 74, 123
- Elmadjian, F., and Pincus, G. (1946)  
J. Clin. Endocrin. Metab., 6, 287
- Ely, R.S., Hughs, E.R., Kelly, V.C. (1958)  
J. Clin. Endocrin. Metab., 18, 190
- Endahl, G.L., Kochakian, C.D. (1962)  
Biochim. Biophys. Acta., 62, 245
- Endahl, G.L., Kochakian, C.D., Hamm, D.I. (1960)  
J. Biol. Chem., 235, 2792

- Engel, F.L. (1950)  
Rec. Prog. Horm. Res., 6, 277
- Engel, F.L. (1950a)  
Rec. Prog. Horm. Res., 6, 649
- Fain, J.N. (1964)  
J. Biol. Chem., 239, 958
- Farrell, G.L., Rosnagle, R.S., Ranschkolb, E.W. (1956)  
Fed. Proc., 15, 60
- Feigelson, F., and Feigelson, M. (1963)  
J. Biol. Chem., 238, 1073
- Ferguson, J.J. (1962)  
Biochim. Biophys. Acta., 57, 616
- Fieser, L.F., and Fieser, M. (1949)  
Natural Products Related to Phenanthrene (Reinhold)
- Fish, C., Hayans, G., Pincus, G., (1953)  
Arch. Biochem. Biophys., 42, 480
- Florini, J.R., and Fuyske, P.A., (1961)  
J. Biol. Chem., 236, 247
- Forchelli, E., and Dorfman, R.I. (1956)  
J. Biol. Chem., 223, 443
- Forchelli, E., Ramachandran, S., Ringold, H.J. (1963)  
Steroids, 1, 157
- Forsham, P.H., Raimondo, V., Island, D., Rinfrei, A.F.,  
Orr, R.H. (1955)  
Ciba Found. Colloq. Endocrin., 3, 279
- Franco, E.G. (1944)  
Endocrin., 34, 175
- Frantz, A.G., Katz, F.H., Jailer, J.W. (1961)  
J. Clin. Endocrin. Metab., 21, 1290
- Fre'mery de, P., Laqueur, E., Reichstein, T., Spanhoff, J.J.,  
Uyldert, I.E. (1937)  
Nature, 139, 26
- Froesch, R.E., Ashmore, J., Renold, A.E. (1958)  
Endocrin., 62, 614
- Fukushima, D.K., Leeds, F.S., Bradlow, H.L., Kritchevsky, T.H.,  
Stokem, M.B., Gallagher, T.F. (1956)  
J. Biol. Chem., 212, 449
- Fukushima, D.K., Bradlow, H.L., Holman, L., Zumoff, B.,  
Gallagher, T.F. (1960)  
J. Biol. Chem., 235, 2246
- Gallagher, C.H. (1960)  
Biochem. J., 74, 38
- Ganis, F.M., Axelrod, L.R., Miller, L.L. (1956)  
J. Biol. Chem., 218, 841
- Garrod, O., Davis, S.A., Cahill, G. (1955)  
J. Clin. Investig., 34, 761
- Gaylord, N.G. (1956)  
Reduction with Complex Metal Hydrides.

- Gemzell, C.A. (1953)  
 J. Clin. Endocrin. Metab., 13, 898
- Gillman, J., Gilbert, C., Epstein, E., Allan, J.C. (1958)  
 Brit. Med. J., 2, 1260
- Glenn, E.M., Bowman, B.J., Bayer, R.E., Meyer, C.E. (1961)  
 Endocrin., 68, 386
- Glenn, E.M., Stafford, R.O., Lyster, S.C., Bowman, B. (1957)  
 Endocrin., 61, 128
- Gold, N.I. (1961)  
 J. Biol. Chem., 236, 1924
- Gold, N.I. (1962)  
 J. Clin. Investig., 41, 1871
- Goodman, H.M., and Knobil, E. (1961)  
 Amer. J. Physiol., 201, 1
- Grant, J.K., Forrest, A., Symington, T. (1957)  
 Acta. Endocrin., 26, 195
- Greengard, O., and Feigelson, P. (1962)  
 Biochem. J., 84, 111p
- Greengard, O., Weber, G., Sughal, M. (1963)  
 Science, 141, 160
- Gregory, J.D., Nose, Y., (1957)  
 Fed. Proc., 16, 189
- Hagen, A.A., and Troop, R.C. (1960)  
 Endocrin., 67, 194
- Hahnel, R. (1965)  
 Anal. Biochem., 10, 184
- Harding, B.W., and Nelson, D.H. (1964)  
 Endocrin., 75, 501
- Haslam, R.M., and Klyne, W. (1952)  
 Lancet, (i) 285
- Havel, R.J., and Goldfein, A., (1959)  
 J. Lipid Res., 1, 102
- Hellman, L., Bradlow, H.L., Adesman, J., Fukushima, D.K.,  
 Tulp, J.L., Gallagher, T.F. (1954)  
 J. Clin. Investig., 33, 1106
- Hellman, L., Bradlow, H.L., Zimoff, B., Gallagher, T.F.  
 (1961)  
 J. Clin. Endocrin. Metab., 21, 1231
- Henkin, R.I., and Knigge, E.M., (1963)  
 Amer. J. Physiol., 204, 710
- Henning, H.V., Seiffert, I., Seubert, W., (1963)  
 Biochim. Biophys. Acta., 77, 345
- Hilton, J.G., Weaver, D.C., Moelheims, C., Glavians, V.V.,  
 Wegria, R. (1958)  
 Amer. J. Physiol., 192, 523
- Holcenberg, J.C., and Rosen, S.W., (1965)  
 Arch. Biochem. Biophys., 110, 551

- Holcombe, R.B., (1957)  
Acta. Endocrin., Suppl. 34
- Holme, L.W., and Firch, G. (1955)  
Amer. J. Vet. Res., 16, 332
- Holners, W.J., and Greenaway, J.M. (1959)  
J. Endocrin., 18, xv
- Hubener, H.J., Fukushima, D.K., Gallagher, T.F. (1956)  
J. Biol. Chem., 220, 499
- Hurlock, B., and Talalay, P. (1958)  
J. Biol. Chem., 233, 886
- Hurlock, B., and Talalay, P. (1959)  
Arch. Biochim. Biophys., 80, 468
- Hyde, F.M., and Williams, R.H. (1954)  
J. Clin. Endocrin. Metab., 14, 817
- Isselbacher, K. (1956)  
Rec. Prog. Horm. Res., 12, 134
- Isselbacher, K., and Axelrod, J. (1955)  
J. Amer. Chem. Soc., 77, 1070
- Izzo, A.J., Keutmann, E.H., Burton, R.B. (1957)  
J. Clin. Endocrin. Metab., 17, 389
- Jacobsohn, G.M., and Levenberg, D. (1965)  
Steroids, 4, 849
- Jedeikin, L.A., and White, A. (1958)  
Endocrin., 63, 226
- Jervell, E.F. (1963)  
Acta. Endocrin., 44, 3
- Katzman, D.A., Straw, E.E., Buehler, H.J., Doisy, E.A. (1954)  
Rec. Prog. Horm. Res., 9, 45
- Lellie, A.E., (1957)  
Biochem. J., 66, 430
- Kemp, A.A., Kappas, I., Salamon, F., Herling, Gallagher, P.F.  
(1957)  
J. Biol. Chem., 122, 227
- Kendall, E.C., Mason, H.L., Hoehn, W.M., McKenzie, B. (1957)  
J. Biol. Chem., 112, lvi
- Kenny, F.T. (1962)  
J. Biol. Chem., 237, 3495
- Killinger, D.W., and Solomon, S. (1965)  
J. Clin. Endocrin. Metab., 25, 290
- Kingsley, G., and Getchell, G. (1961)  
Analyt. Biochem., 2, 1
- Kitay, J.I., Holub, D.A., Jailer, J.W. (1959)  
Endocrin., 64, 475
- Kleeman, C.R., Czaozkes, J.W., Cutler, R. (1965)  
J. Clin. Investig., 44, 1641
- Klempien, E.J., Voit, K.D., Tamm, J., (1961)  
Acta. Endocrin., 36, 498

- Klyne, W. (1953)  
Ciba Found. Colloq. Endocrin., 7, 127
- Klyne, W. (1957)  
The Chemistry of the Steroids, (Methuen)
- Kochakian, C.D., and Hall, D.M. (1953)  
J. Biol. Chem., 204, 91
- Kochakian, C.D., and Robertson, E., (1951)  
J. Biol. Chem., 190, 495
- Koepf, G.F., Horn, H.W., Gemmill, C.L., Thorn, G.W. (1941)  
Amer. J. Physiol., 135, 175
- Koerner, D.R., and Hellman, L. (1964)  
Endocrin., 75, 592
- Kornel, L. (1962)  
J. Clin. Endocrin. Metab., 22, 1079
- Kornel, L., (1963)  
J. Clin. Endocrin. Metab., 23, 1192
- Kraiem, Z., Lunenfeld, B., Skalka, J. (1969)  
Acta. Endocrin., 61, 1
- Krum, A.A., Morris, M.D., Bennett, L.L. (1964)  
Endocrin., 74, 543
- Kuizenga, H.W., and Cartland, G.F. (1939)  
Endocrin., 24, 526
- Kushinsky, S., and Tang, J. (1963)  
Acta. Endocrin., 43, 361
- Laidlaw, J.C., Dingman, J.F., Arono, W.L., Winkenstaedt, J.,  
Thorn, G.W. (1955)  
Ann. N.Y. Acad. Sci., 61, 315
- Laidlaw, C., Jenkins, D., Reddy, W.J., Jakobson, T. (1954)  
J. Clin. Investig., 33, 950
- Lambert, M., and Pennington, G.W. (1965)  
J. Endocrin., 32, 287
- Landau, B.R. (1960)  
Endocrin., 67, 744
- Langstroth, G.C., Talbot, N.B., Fineman, A. (1939)  
J. Biol. Chem., 130, 585
- Levine, R., Simkin, B., Cunningham, W. (1949)  
Amer. J. Physiol., 159, 111
- Levitz, M., Condon, G.P., Money, W.L., Dancis, J. (1960)  
J. Biol. Chem., 235, 973
- Levy, G.A., and Conchie, J. (1966)  
Methods in Enzym., 8, 575
- Lewis, R.A., Kuhlman, D., Delbue, C., Koepf, G.F.,  
Thorn, G.W., (1940)  
Endocrin., 27, 971
- Liddle, G.W., Island, D., Lance, E.M., Harris, A. (1958)  
J. Clin. Endocrin. Metab., 18, 906

- Lieberman, S., Fukushima, D.K., Dobriner, K. (1950)  
J. Biol. Chem., 182, 299
- Lieberman, S., Mond, B., Smyles, E. (1954)  
Rec. Prog. Horm. Res., 9, 401
- Lindner, H.R. (1959)  
Nature, (Lond.) 184, 1645
- Lindner, H.R. (1961)  
J. Endocrin., 23, 139
- Lindner, H.R., (1964)  
J. Endocrin., 28, 301
- Lindner, H.R. (1965)  
Steroids, 6, Suppl II
- Lipman, M.M., Katz, F.H., Jailer, J.W. (1962)  
J. Clin. Endocrin. Metab., 22, 268
- Lipsett, M.N., and Moore, J.F. (1951)  
J. Biol. Chem., 192, 743
- Lisboa, B.P. (1964)  
J. Chromatog., 15, 136
- Lisboa, B.P. (1968)  
Lipid Chromatographic Analysis, (Ed. Marinetti)  
Vol., 2, 123
- Long, C.N.H., Katzin, B., Fry, E.G. (1940)  
Endocrin., 26, 309
- Long, C.N.H., Smith, O.K., Fry, E.G. (1960)  
Metabolic Effects of Adrenal Horm., 6, (Churchill)
- Lynn, W.S., and Brown, R.H. (1958)  
J. Biol. Chem., 232, 1015
- Mader, J., and Buck, R.R. (1952)  
Biochim. Biophys. Acta., 24, 666
- Mahesh, V.B., and Ulrich, F. (1959)  
Nature, 184, 1147
- Marlow, H.W. (1950)  
J. Biol. Chem., 183, 167
- Mason, H.L. (1950)  
J. Biol. Chem., 182, 131
- Mason, H.L., (1954)  
Rec. Prog. Horm. Res., 9, 267
- Mason, H.L., Hoehn, W.M., Kendall, E.C. (1938)  
J. Biol. Chem., 124, 459
- Mason, H.L., Hoehn, W.M., Kendall, E.C. (1938a)  
J. Biol. Chem., 124, 475
- Mason, H.L., Hoehn, W.M., McKenzie, B.F., Kendall, E. (1937)  
J. Biol. Chem., 120, 719
- Mason, H.L., Meyers, C.S., Kendall, E.C. (1936)  
J. Biol. Chem., 114, 613
- Mason, H.L., Meyers, C.S., Kendall, E.C. (1936a)  
J. Biol. Chem., 116, 267

- Mathews, J.S. (1963)  
Biochim. Biophys. Acta., 69, 163
- Menini, E., and Worymborski, J.K. (1965)  
Biochem. J., 95, 1
- Meyer, A.S. (1955)  
Biochim. Biophys. Acta., 24, 1435
- Migeon, C.J. (1962)  
J. Clin. Investig., 41, 2025
- Migeon, C.J., Sandberg, A.A., Paul, A.C. Samuels, L. (1956)  
J. Clin. Endocrin. Metab., 16, 1291
- Migeon, C.T., Tyler, F.H., Mahoney, J.P. Florentin, A.A.,  
Castle, H., Bliss, E.L., Samuels, L.T. (1956)  
J. Clin. Endocrin. Metab., 16, 622
- Miller, W.R., Turner, C.W., Fukushima, D.K., Salamon, J.J.  
(1956)  
J. Biol. Chem., 220, 221
- Mills, I.H. (1962)  
Brit. Med. Bull., 18, 127
- Mills, I.H., Schedl, A.P., Chen, P.S., Bartter, F.C. (1960)  
J. Clin. Endocrin. Metab., 20, 515
- Mixner, J.F., Saunders, H.L., Johnston, J.E. (1957)  
J. Dairy Sci., 40, 66
- Munck, A. (1962)  
Biochim. Biophys. Acta., 57, 318
- MacDonald, I.R., and Riech, M. (1959)  
J. Physiol., 147, 33
- McAlleer, W.J., and Mozlowski, M. (1957)  
Arch. Biochem. Biophys., 66, 120
- McGuire, J.S., and Tomkins, G.M. (1959)  
Fed. Proc., 18, 286
- McGuire, J.S., and Tomkins, G.M. (1960)  
J. Biol. Chem., 235, 1634
- Narasimhulu, S., Keswani, I., Flickinger, G.L. (1968)  
Steroids, 12, 1
- Neeman, M., Slaunwhite, W.R., Neely, L.M., Colson, J.G.,  
Sandber, A.A. (1960)  
J. Biol. Chem., 235, 58
- Nelson, D.H., Egdahl, R.H., Hume, D.M. (1956)  
Endocrin., 58, 309
- Nelson, D.H., Samuels, L.T., Willardson, D.G., Tyler, F.B.  
(1951)  
J. Clin. Endocrin. Metab., 11, 1021
- Nelson, D.H., Tanney, H., Mestman, J.H., Gieschen, V.  
(1962)  
Excerpta Medica, Int. Cong. Horm. Steroids, 89
- Nichols, T., Nugent, C.A., Tyler, F.H. (1965)  
J. Clin. Endocrin. Metab., 25, 343

- Nishizawa. (1963)  
J. Chromatog., 10, 493
- Norymberski, J.K. (1953)  
Mem. Soc. Endocrin., 10, 64
- Norymberski, J.K., and Stubbs, R.D. (1956)  
Biochem. J., 64, 168
- Norymberski, J.K., and Woods, C.F. (1955)  
J. Chem. Soc., 3426
- Oertel, G.W., and Eik-Nes, K. (1958)  
Fed. Proc., 17, 400
- Cliveto, E.P., and Hershberg, E.B. (1953)  
J. Amer. Chem. Soc., 75, 488
- Orzel, R. (1967)  
Canadian J. Bio., 45, 134
- Ocinski, P.A. (1960)  
Nature, 187, 777
- Pasqualini, J.R., and Jale, M.F. (1961)  
Biochem. J., 81, 147
- Pasqualini, J.R. (1967)  
Steroid Horm. Analysis. (Ed. Carstensen)
- Paterson, J.Y.F. (1963)  
Biochem. J., 86, 1p
- Paterson, J.Y.F., and Harrison, F.A. (1967)  
J. Endocrin., 37, 269
- Paterson, J.Y.F., and Hills, F. (1967)  
J. Endocrin., 37, 261
- Paterson, J.Y.F., and Harriian, G.F. (1951)  
Biochem. J., 48, xxxiii
- Feron, P.G., and Dorfman, R.I. (1956)  
J. Biol. Chem., 223, 877
- Peterson, R.E., and Wyngaarden, J.B. (1956)  
J. Clin. Investig., 35, 552
- Peterson, R.E., Pierce, C.E., Wyngaarden, J.B.,  
Bunim, J.J., Brodie, B.B. (1957)  
J. Clin. Investig., 36, 1301
- Pincus, G., Romanoff, L.P., Carlo, J. (1948)  
J. Clin. Endocrin. Metab., 8, 221
- Plager, J.E., Tyler, F.H., Hecht, H.H., Samuels, L. (1954)  
J. Clin. Endocrin. Metab., 14, 780
- Ray, P.D., Foster, D.O., Lardy, H.A. (1964)  
J. Biol. Chem., 239, 3396
- Recknagel, R.O. (1957)  
J. Biol. Chem., 227, 273
- Recknagel, R.O., and Litteria, M. (1956)  
J. Lab. Clin. Med., 48, 463
- Reichstein, T. (1936)  
Helv. Chim. Acta., 19, 1107

- Reichstein, T. (1937)  
Helv. Chim. Acta. 20, 953
- Repke, K., and Samuels, L.T. (1964)  
Biochemistry, 3, 689
- Richards, J.B., and Pruitt, R.L. (1957)  
Endocrin., 60, 99
- Riech, M. (1960)  
Aust. J. of Exptl. Biol., 38, 175
- Riggs, T.R. Actions of Hormones on Molecular Processes,  
(Ed. Litwack, G., & Kritchevsky, D.) N.Y.
- Roberts, J.B., Bush, I.E., Gibtree, N.B. (1968)  
Analyt. Biochem., 23, 378
- Roberts, K.E., Randall, H.T. (1955)  
Ann. N.Y. Acad. Sci., 61, 306
- Roberts, S., and Szego, C.M. (1953)  
Physiol. Rev., 33, 593
- Robertson, W.C., and Mixner, J.P. (1953)  
J. Animal Sci., 12, 799
- Robins, P.W., and Lipman, F. (1956)  
J. Amer. Chem. Soc., 78, 2652
- Romanoff, L.P., Morris, C.W., Welch, P., Rodriguez, R.M.,  
Pincus, G. (1961)  
J. Clin. Endocrin. Metab., 21, 1413
- Rubin, B.L. (1957)  
J. Biol. Chem., 227, 917
- Rubin, B.L., and Strecker, H.J. (1961)  
Endocrin., 69, 257
- Ruliffson, W.S., Bell, P.D., Hughes, J.S., Funn, A. (1954)  
J. Animal Sci., 13, 1030
- Sandberg, A.A., and Slaunwhite, W.R. (1959)  
J. Clin. Investig., 38, 1290
- Sandberg, A.A., Chang, E., Slaunwhite, W.R. (1957)  
J. Clin. Endocrin. Metab., 17, 437
- Sandberg, A.A., Slaunwhite, W.R., Antoniades, H.N. (1957)  
Rec. Prog. Horm. Res., 13, 209
- Sandberg, A.A., Slaunwhite, W.R., Carter, A.C. (1960)  
J. Clin. Investig., 39, 1914
- Sandberg, A.A., Eik-Nes, K., Nelson, D.H., Tyler, F. (1954)  
J. Lab. Clin. Med., 43, 874
- Sandberg, A.A., Nelson, D.H., Glenn, E.M., Tyler, F.H.,  
Samuels, L.T. (1953)  
J. Clin. Endocrin. Metab., 13, 1445
- Sarrett, L.H. (1946)  
J. Biol. Chem., 162, 601
- Savard, K., and Casey, P.J. (1964)  
Endocrin., 74, 599

- Savard, K., and Goldfaden, S.H. (1954)  
Fed. Proc., 13, 288
- Savard, K., and Goldfaden, S.H. (1954a)  
Fed. Proc., 13, 1238
- Savard, K., Kolff, W.J., Corcoran, A.C. (1952)  
Endocrin., 50, 366
- Sayers, G. (1950)  
Physiol. Rev., 30, 241
- Schneider, J.J. (1952)  
J. Biol. Chem., 194, 337
- Schneider, J.J., and Leubart, H.L. (1956)  
J. Biol. Chem., 222, 787
- Schneider, J.J., and Mason, H.L. (1948)  
J. Biol. Chem., 175, 231
- Schreiber, J., Eschenmoser, A. (1955)  
Helv. Chim. Acta., 38, 1529
- Scriba, P.C., and Reddy, H.J. (1965)  
Endocrin., 76, 745
- Seal, U.S., and Doe, R.P. (1962)  
J. Biol. Chem., 237, 3136
- Sharma, C., Manjishwar, R., Weinhouse, S. (1963)  
Adv. Enz. Regulat., 2, 189
- Sigler, M.H., Forrest, J.N., Elkington, J.R. (1965)  
Clin. Sci., 28, 29
- Silber, R.H., and Porter, C.C. (1953)  
Endocrin., 52, 518
- Slaunwhite, W.R., and Sandberg, A.A. (1958)  
Endocrin., 62, 283
- Slaunwhite, W.R., and Sandberg, A.A. (1959)  
J. Clin. Investig., 38, 384
- Slaunwhite, W.R., Neeley, L., Sandberg, A.A. (1964)  
Steroids, 3, 391
- Sobotka, H., and Bloch, E. (1943)  
Ann. Rev. Biochem., 12, 45
- Sondheimer, F.C., Velasco, H., Batres, E., Rosenkranz, G.  
(1954)  
Chem. and Ind., (1954), 1482
- Stahl, E. (1969)  
Thin Layer Chromatography, 2nd Edition.
- Starnes, W.R., Partlow, T.F., Grammer, M.C., Kornel, L.,  
Hill, S.R. (1963)  
Anal. Biochem., 6, 82
- Starnes, W.R., Rhodes, A.H., Lindsay, R.H., (1966)  
J. Clin. Endocrin. Metab., 26, 1245
- Szego, C.M., and Roberts, S. (1953)  
Rec. Prog. Horm. Res., 8, 419

- Pait, J.F., and Burstein, S. (1964)  
The Hormones. (N.Y. Academic Press)
- Pait, J.F., Simpson, S.A., Grundy, H. (1952)  
Lancet, 1952-1, 122
- Talalay, P., Dobson, R.E., Tapley, D.F. (1952)  
Nature, 170, 620
- Talbot, A.D., Berman, R.A., MacLachlan, E.A. (1942)  
J. Biol. Chem., 143, 211
- Teng, C.T., (1954)  
Arch. Biochem. Biophys., 48, 409
- Thomas, F., and Dorfman, R.I. (1964)  
J. Biol. Chem., 239, 766
- Thorn, G.W. (1955)  
Ciba Found. Colloq. on Endocrin., 8, 651
- Thorn, G.W., Loepf, G.E., Lewis, R.A., Olsen, E. (1940)  
J. Clin. Investig., 19, 313
- Tomkins, G.H. (1956)  
J. Biol. Chem., 218, 437
- Tomkins, G.H. (1957)  
J. Biol. Chem., 225, 13
- Tomkins, G.H., and Isselbacher, K.J. (1954)  
J. Amer. Chem. Soc., 76, 3100
- Troop, R.C. (1959)  
Endocrin., 64, 671
- Eschesche, R. (1961)  
J. Chromatog., 5, 271
- Tyler, F.H., Nigeon, G., Florentin, A.A., Samuels, L. (1954)  
J. Clin. Endocrin. Metab., 14, 774
- Uete, T., and Ashmore, J. (1963)  
J. Biol. Chem., 238, 2906
- Ulrich, F. (1958)  
Biochem. J., 68, 361
- Ungar, F. (1960)  
Acta. Endocrin., Suppl. 51, 727
- Ungar, F., and Bloom, B.R. (1957)  
Biochim. Biophys. Acta., 24, 431
- Ungar, F., and Dorfman, R.I. (1954)  
J. Amer. Chem. Soc., 76, 1197
- Ungar, F., and Dorfman, R.I. (1965)  
Metab. of Steroid Hormones
- Ungar, F., and Halberg, F. (1962)  
Science, 137, 1058
- Ungar, F., Davis, J.W., Rosenkrantz, H., Dorfman, R. (1954)  
J. Biol. Chem., 207, 375
- Upton, G.V., and Bondy, P.K. (1958)  
Arch. Biochem. Biophys., 78, 197

- Urquhart, J. (1965)  
Amer. J. Physiol., 209, 1162
- Utter, M.F., Keech, B., Scrutton, M.O. (1963)  
Adv. Enz. Regulat., 2, 49
- Van der Straeten, M., Vermeuten, A., Norie (1963)  
Acta. Endocrin., 43, 430
- Vogt, M., (1951)  
J. Physiol., 113, 129
- Von Bitto (1892)  
Ann. Chem., 209, 377
- Wagle, S.R., and Ashmore, J. (1961)  
J. Biol. Chem., 236, 2868
- Watanabe, S. (1965)  
Steroids, 6, 207
- Weissmann, G., and Thomas, L. (1964)  
Rec. Prog. Horm. Res., 20, 215
- Werbin, H., and Chaikoff, I.L. (1961)  
Ann. Biochem., 93, 476
- West, C.D., Tyler, F.H., Brown, H., Samuels, L.T. (1951)  
J. Clin. Endocrin. Metab., 11, 897
- Westphal, U. (1964)  
J. Amer. Oil Chem. Soc., 41, 481
- Westphal, U., and Ashley, B.D. (1959)  
J. Biol. Chem., 234, 2847
- Whitten, W.X. (1943)  
Aust. J. Exp. Biol. Med. Sci., 21, 187
- Wiest, W.G., Wilcox, R.B. (1961)  
J. Biol. Chem., 236, 2425
- Willmer, E.N. (1961)  
Biol. Rev., 36, 368
- Wilson, H., Fairbanks, R., Scialabba, D. (1954)  
J. Clin. Endocrin. Metab., 14, 814
- Wintersteiner, O., Pfiffner, J.J. (1936)  
J. Biol. Chem., 116, 291
- Wool, I.G., Weinshelbaum, E.I. (1959)  
Amer. J. Physiol., 197, 1089
- Wotiz, H.H., and Clark, S.J. (1968)  
Gas Chromatography of Steroid Hormones.
- Wyngaarden, J.B. (1955)  
J. Biol. Chem., 212, 963
- Wyngaarden, J.B., Petersen, R.E., Wolff, A.R. (1955)  
J. Biol. Chem., 212, 963
- Wynne, K. (1954)  
Aust. J. Sci., 17, 36
- Yates, F.E., Herbst, A.L., Urquhart, J. (1958)  
Endocrin., 63, 887

- Zaffaroni, A. (1950)  
J. Amer. Chem. Soc., 72, 3828
- Zaffaroni, A., Burton, R.B. (1953)  
Arch. Biochem. Biophys., 42, 1
- Zimmerman, W. (1935)  
Z. Physiol. Chem., 233, 257