

Copyright is owned by the Author of the thesis. Permission is given for a copy to be downloaded by an individual for the purpose of research and private study only. The thesis may not be reproduced elsewhere without the permission of the Author.

**A GENETIC IMPROVEMENT PROGRAMME FOR
NEW ZEALAND DAIRY GOATS**

A thesis presented in partial fulfilment of the requirements for the

Degree of

Doctor of Philosophy

in

Animal Science

At Institute of Veterinary, Animal and Biomedical Sciences (IVABS)

Massey University, Palmerston North,

New Zealand

Jose Solis-Ramirez

2014

ABSTRACT

The establishment of genetic improvement programmes is an important aspect of any modern animal production industry. The New Zealand dairy goat industry has no national genetic improvement programme aimed at improving performance in economically important traits. A survey of dairy goat farmers was undertaken to collect information about their farming systems. Does were kept under indoor conditions and averaged (and standard deviation) of 2.8 ± 0.2 litres of milk per day. Information on herd structure, reason for culling and death, milk-solids concentration and production, cost of production, revenue and management was collected. Four mathematical models were evaluated using random regression models to estimate lactation yields from test-day records. The Wilmink model (WK) was chosen as the best model based on AIC fit statistic. Does which were 75% Saanen and 25% other breeds or Toggenburg produced the highest milk yield (MY), fat yield (FY) and protein yield (PY), while Toggenburg does produced the lowest yields. Information from the survey was used to develop a deterministic bio-economic model to estimate economic values (EVs) for four payment scenarios. The breeding objective included seven traits: MY, FY, PY, lactose yield (LY), liveweight (LW), longevity (LGTY) and Somatic cell score (SCS). For the Current payment system in New Zealand (payment on milk-solids) the EVs were NZ\$11.64, NZ\$12.27, NZ\$12.39, NZ\$-0.10, NZ\$-2.15, NZ\$0.04 and NZ\$-8.22, respectively. Heritabilities and repeatabilities were estimated using uni- and bivariate animal model analyses with two random variables (animal for additive genetic component and doe for animal permanent environmental component). Heritabilities for MY, FY and PY were all 0.21 and 0.22 for SCS with similar standard errors. Repeatabilities ranged from 0.40 for MY, FY and PY to 0.49 for SCS. Genetic and phenotypic correlations between milk traits were positive and high, while between milk traits and SCS were from positive low to low negative. These parameters suggest moderate favourable responses to selection for increased milk solids and reduced SCS. Genetic gain and responses in the traits in the breeding objective were estimated for pedigree and progeny testing selection schemes using a selection index for one (MS) or three traits (MY, FY and PY). Results suggested that higher genetic gain and responses in individual traits occurred using a progeny test scheme. The information generated from this research should be applied to the New Zealand dairy goat industry to improve farm profit per milking doe.

Keywords: Dairy goats, lactation curves, breeding groups, economic values, genetic parameters, selection schemes.

DEDICADA A LAS PERSONAS QUE MÁS AMO

(Dedicated to my most beloved people):

A dios, nuestro señor: Por darnos vida y esperanza (To God for life and hope).

A mi familia (To my family):

Quienes compartieron conmigo la alegría y la nostalgia. Ellos saben de mis alegrías, restricciones y pensamientos por los que pase durante mis estudios doctorales (They share joy and sorrow with me. They knew all about my happiness, restrictions and thoughts while doing my doctorate studies):

Elizabeth, my wife Ely, José Vicente (Chente), Adriana Elizabeth (Ady), Jorge Alberto (Gordito) and Diana Isabel (Didi).

A mis padres (To my parents): Lucía Ramírez y Vicente Solís,

A mi hermano (to my brother) Alberto y a mi hermana (and to my sister)

Lucía Guadalupe.

A la memoria de mis abuelos

(In memory of my grandparents):

Balvina Ramírez (Mamá Bina), Isidro Ramírez (Papá Childo), Vicente Solís (Papá Chente) and Aurora Ramírez (Mamá Gola).

Dios los bendiga

God bless you

ACKNOWLEDGEMENTS

My sincere gratitude to my chief supervisor Professor Hugh Thomas Blair and Co-supervisor Professor Nicolas Lopez Villalobos for their assistance, guidance and supportive supervision through my doctoral studies at Massey University. Professor Hugh Thomas Blair, Director of Research and Commercialization at the Institute of Veterinary, Animal and Biomedical Sciences (IVABS), enlightened me in understanding the concept of farm modelling and the designing of breeding programmes for livestock production. He made himself available at all times to provide valuable assistance in both personal and tutorial or professional matters and his constant source of constructive criticism, comment and encouragement above and beyond the call of duty was invaluable in the completion of this thesis. Also I keep in mind the very good time at Jensen and Tremaine with family and friends around. Thank you so much Professor Blair. Professor Nicolas Lopez-Villalobos provided me with invaluable knowledge in understanding animal breeding and mathematical statistics with analysis. His constant support and help encouraged me in this study. I cannot possibly express fully, the level of his unlimited cooperation and assistance in my completing of this thesis. Besides, every academic or general chat always was enjoyable. Thanks to you and your family.

I would like to thank all personnel of Postgraduate and Research studies office, especially to Professor Kevin Stafford, Director of Postgraduate studies at IVABS and Miss Debbie Hill postgraduate and research administrator and also to Kristen Story and Wendy Graham. Friendly support from Prof Frazer Allan Head of IVABS, Prof Paul Kenyon, Prof. Danny Donaghy, Prof. Tom Barry, Prof. Colin Homes, Prof. Stephen Morris, Dr. Gina De Nicolo, Dr. Dany Aberdein, Dr. Keren Dittmer, Dr. Jimena Yapura, Dr. Sarah Pain, Dr. Rebecca Hickson, Dr. Rene Corner, Dr. Penny Back, Dr. Rao and Dr. Kavita Dukkipatie, Dr. Sam Peterson. Dr. Karren Dittmer, Dr. Kerri Morgan, Dr. Rachel Stratton, Dr. Kiro Petrousky, Dr. Alex Grinberg, Mr. Mohan Ponnampalam, Mr. Allan Nutman, and also to postgraduate students that make us have a great time in New Zealand: Emilie Vallee, Aluna Chawala, Supatsak Subharat (Art), Sharini Sinhadipathige, Shashwati Ambatkar, Doris Adeyinka, Nish de Silva, Sarah Azarpeykan, Tessy George Maria Luoreiro, Lidia Cave, Nick Sneddon, Emi Patten, Deepa Patel, Kandarp Patel, David Silva-Villacorta, Asmad Kari, Aaron S. Sucrose, Suryani Eka Wijaya, Kruno Bojanic, Nelly Marquetoux, Masako Wada, Mirjan Guesgen, Linda Raven, Lisanne Fermin, Antoinette Danso, Santosh K. Sahu, Komal Arora, Dante Guzman, Sandeep Karna, Shameer Siddiqui, Ali Karkaba, Sulav Shrestha, Rima Shrestha, Gustavo Chamon, Odelin Brea, Lisanne Fermin, Heidi Jack, Gauri More, Gabriella Gronqvist and so many postgraduate and visitor students from

many countries. Special thanks to Judy Lee, for all your support. I still keep the book, the jug, the hanky, the video-song and lots of wonderful memories and the most important thing, your friendship.

Thanks to the New Zealand Dairy Goat Cooperative, to Dr. Colin Prosser and all the dairy goat farmers who allowed me to go through their farms and provided me with information for my thesis. Thank you to all of you. It was a great experience for me to be around you. Also, Thanks for the support and proofreading from Dr. Don Otter and Dr. Julia Rayner.

I would like to give thanks to my endless and kind New Zealand friends: Alana, Hugh, Victoria and James Blair, Mr. Jeremy and Diana Neild and their lovely children: David, Susanne, Michael and Sylvia. We love you guys. You have been so important for me and my family.

To my dear Latin-American friends Javier and Ana Baudracco, Daniela Tapia and Juan Sanhueza, Alfredo and Loreto Lepori, Francisco and Valentina Sales, Gonzalo and Berenice Tuñon, Felipe and Macarena Lembeye, Javier Roca, Marcela Almiron y sus hijos Pablo y Melody, Cynthia Landa, Mariani Rivera, Natalia (Martin) and Grant, Natalia Banquets, Lisa Valenzuela, Leonel Alvarado, Celina Bartolotto and Ronaldo Vibart, German y Vilma Molano, Alvaro Wehrle, Don Luis, Ana and Danilo Herrera, Gloria Martinez, Ana A. Ivory, Claudia Juarez, Veronica and Hernan, Rafael and Carolina Cardoso, Andres and Carolina, Nery Juarez and Alex Ramos, Mauricio and Patricia Maldonado and so many friends whom make us feel close to home. Time was not the same without my unforgettable Wednesday soccer day: Thanks Andrew Rodwart, Mohamed abdalla, Robin Mann, Ralph Sims, Paul, Rob Ward, Don and Sam Otter, Pablo Hernandez, Bill, Sumi, Andy, Simon Vale, Phillip, Russell J. Kwa, Elisha Masoe, Keagan,, Ian Keyes, Wade Mace, Raiden Keys, Anthony Pita, Robbie Laird, Ali Karkaba, Vaseen Mirza, Matt Henry, Santiago Villacres, Juan, Felipe, Javier, Rex Mauricio, Ali Alhajouj, Latinos United soccer team specially to Fabian and Joseph from Palmy and many other good soccer players and friends. I would like to express our appreciation to Phil and Debbie Ramsey as well as to Ms Jeanette Burnett, John Ross and Doreen Da silva, for your friendship and your love for Mexico.

This thesis and my stay in New Zealand was made possible thanks to the financial support of the National Science and Technology Council of Mexico (CONACYT), the Universidad Autonoma Chapingo, Mexico, my chief supervisor Professor Hugh Thomas Blair and the Dairy Goat Cooperative of New Zealand, Ltd.

I will never end up thanking to you all, but I do amazingly appreciate what you did for us.

TABLE OF CONTENTS

ABSTRACT	I
ACKNOWLEDGEMENTS	III
TABLE OF CONTENTS	VII
LIST OF TABLES	XIII
LIST OF FIGURES	XVII
LIST OF APPENDICES	XIX
CHAPTER 1	
INTRODUCTION	1
CHAPTER 2	
A LITERATURE REVIEW ON SOME ASPECTS OF THE GENETIC IMPROVEMENT OF DAIRY GOATS	5
INTRODUCTION	7
BREEDING GOALS AND OBJECTIVES	9
DEVELOPMENT OF BREEDING OBJECTIVES	12
Specification of breeding, production and marketing systems	12
Identification of sources of income and expense	14
Determination of biological traits influencing income and expense	15
Derivation of economic values for important traits	16
DEFINITION OF BREEDING OBJECTIVES	18
SELECTION CRITERIA	19
LACTATION TRAIT CURVES IN DAIRY GOATS	20
GENETIC IMPROVEMENT PROGRAMMES	24
CONCLUSIONS	28
CHAPTER 3	
DAIRY GOAT PRODUCTION SYSTEMS IN WAIKATO, NEW ZEALAND	29
ABSTRACT	31
INTRODUCTION	31
MATERIALS AND METHODS	32
Location of study site	32
Format construction and features of survey	32
Herd structure	33
Deaths and culling	33
Breed groups	33

Farm revenues	33
Cost of production	34
Capital value	34
Return on investment	35
RESULTS AND DISCUSSION	35
General farm characteristics	35
Breed groups	35
Herd structure	35
Deaths and culling age	37
Milk and milk-solids production	37
Farm expenses and overheads	40
Farm revenue	40
Return on investment	41
CONCLUSIONS	41
CHAPTER 4	
MODELLING OF LACTATION CURVES FOR NEW ZEALAND DAIRY	
GOATS USING RANDOM REGRESSION MODELS: SELECTION OF THE	
BEST MATHEMATICAL MODEL	43
ABSTRACT	45
INTRODUCTION	45
MATERIALS AND METHODS	48
Data	48
Modelling of the lactation curve	48
Random regression model (RRM)	48
Mathematical models	50
Identification of typical and atypical lactation curves	53
Fit statistics of the mathematical models	53
Statistical analysis	56
RESULTS	57
Population lactation curves	57
Individual lactation curves	58
Fit statistics	59
DISCUSSION	63
Population lactation curves	63
Individual lactation curves	64
Model fitness	64
CONCLUSIONS	67
APPENDICES OF CHAPTER 4	69

CHAPTER 5
MODELLING OF LACTATION TRAIT CURVES FOR NEW ZEALAND
DAIRY GOATS USING RANDOM REGRESSION MODELS: LACTATION
TRAIT CURVES BY BREED GROUP AND LACTATION NUMBER 73

ABSTRACT	75
INTRODUCTION	75
MATERIALS AND METHODS	77
Data and dairy goat herd	77
Breed and lactation groups	78
Modelling of lactation curves	78
Random regression analysis	78
Wilmink model	79
Fit statistics	80
Statistical analysis	82
RESULTS	82
Breed groups	82
Parity number	83
Fit statistics	83
DISCUSSION	87
Lactation curves	87
Concordance correlation coefficient (CCC)	89
CONCLUSION	90
APPENDICES TO CHAPTER 5	91

CHAPTER 6
LACTATION CURVES FOR NEW ZEALAND DAIRY GOATS USING
RANDOM REGRESSION MODELS: LACTATION YIELDS OF MILK FAT
AND PROTEIN BY BREED GROUP AND LACTATION NUMBER 97

ABSTRACT	99
INTRODUCTION	99
MATERIALS AND METHODS	101
Data and farming system	101
Breed and lactation groups	101
Milk, fat and protein yield	102
Modelling of lactation curves	102
Random regression models (RRM)	102
Wilmink model and fitness of the model	102
Concordance correlation coefficient	103
Statistical analysis	103

RESULTS	103
Milk, fat and protein production in the total population	103
Milk, fat and protein production per breed group	104
Milk, fat and protein production per lactation number	104
Concordance correlation coefficient	104
DISCUSSION	107
Lactation yield of milk, fat and protein in the population	107
Production per breed group	107
Production per lactation number	108
CONCLUSIONS	108
APPENDICES TO CHAPTER 6	111
CHAPTER 7	
A BIO-ECONOMIC FARM MODEL FOR THE ESTIMATION OF ECONOMIC VALUES	113
ABSTRACT	115
INTRODUCTION	115
MATERIALS AND METHODS	118
Description of the production system	118
Components of the model	118
Management, payment and dead and culled rate	119
Energy and dry matter requirements	120
Dry-matter intake (DMI)	123
Feed costs	123
Income	124
Profit	125
Traits studied	125
Milk yield and milk-solids production traits	125
Longevity	125
Somatic cell score (SCS)	126
Payment scenarios for milk and milk-solids	127
Calculating economic values	127
Milk, milk-solids and liveweight traits	127
Longevity	128
Somatic cell score	128
Relative economic value (REV)	129
Sensitivity analysis of economic values	130
RESULTS	130
Herd structure, dead and culling rate	130
Milk and milk-solids production	130

Growth curves	131
Metabolic energy and feed intake	131
Longevity	132
Somatic cell score	132
Farm revenue, cost and profit	132
Economic values for traits studied	133
Sensitivity of economic values to changes in costs and prices	137
DISCUSSION	140
The model	140
Economic values for traits	141
Sensitivity analysis	145
CONCLUSIONS	146
CHAPTER 8	
ESTIMATION OF GENETIC PARAMETERS FOR MILK TRAITS AND SOMATIC CELL SCORE IN NEW ZEALAND DAIRY GOATS	149
ABSTRACT	151
INTRODUCTION	151
MATERIALS AND METHODS	153
Data, traits and herd	153
Estimation of variances and covariances	153
Univariate analysis	154
Bivariate analysis	155
Estimation of genetic parameters	156
RESULTS	157
Heritability and repeatability estimates	157
Genetic and phenotypic correlations	157
DISCUSSION	158
Heritability and repeatability	158
Genetic and phenotypic correlations	159
CONCLUSIONS	161
APPENDICES TO CHAPTER 8	163
CHAPTER 9	
SELECTION SCHEMES FOR NEW ZEALAND DAIRY GOATS	169
ABSTRACT	171
INTRODUCTION	172
MATERIALS AND METHODS	174
Herd structure	174
Breeding objectives and selection schemes	174

Genetic and phenotypic parameters and bending process	176
Selection Index	176
Genetic gain	182
First selection stage	182
Second selection stage	182
RESULTS	184
DISCUSSION	189
Genetic gain in the objectives	189
Genetic gain in traits	191
CONCLUSIONS	193
APPENDICES TO CHAPTER 9	195
CHAPTER 10	
GENERAL DISCUSSION	197
INTRODUCTION	199
MAIN POINTS FROM THIS STUDY	199
LIMITATIONS	201
FUTURE CHALLENGES AND DIRECTION	202
CONCLUSIONS	206
REFERENCES	207

LIST OF TABLES

Table 2.1. Heritabilities, repeatabilities, genetic and phenotypic correlations in goats for milk, fat and protein yield from different sources ¹	22
Table 3.1. Main expenses recorded in the dairy goat farm.	34
Table 3.2. Number and percentage of animals per breed group in the whole dairy goat herd (does, bucks and kids) and in the milking does.	36
Table 3.3. Herd structure per age of the dairy goat farm.	38
Table 3.4. Culling and deaths of milking does in the dairy goat herd.	38
Table 3.5. Daily milk and milk-solids production, percentage values for cost of production, revenues and return on investment per milking doe and per hectare of dairy goat farms in New Zealand.	39
Table 4.1. Distribution of test day records along the lactation period adjusted to 270 days.	48
Table 4.2. Least square means (standard errors) ¹ of the parameters of the lactation curve obtained from four mathematical models for milk traits of New Zealand dairy goats.	58
Table 4.3. Number of typical and atypical lactation curves for milk (MY), fat (FY) and protein (PY) yield using four mathematical models in New Zealand dairy goats.....	59
Table 4.4. Measures of statistical fitness for four mathematical models to describe the lactation curve of daily yields of milk, fat and protein in New Zealand dairy goats.	60
Table 5.1. Number of test-day records, number of milking does per breed group and per lactation number.	81
Table 5.2. Least square means (and standard errors) of estimates of regression coefficients of the Wilmink model for milk (MY), fat (FY) and protein (PY) yield model parameters (standard error) for 5 breed groups and five lactations in New Zealand dairy goats.	84

Table 5.3. Concordance correlation coefficient (and standard errors) for daily milk (MY), fat (FY) and protein (PY) yield curves using Wilmink model and levels of significance for 5 breed groups and five lactations of New Zealand dairy goats.....	87
Table 6.1. Least square means (standard errors) and significance levels for milk, fat and protein yield at actual lactation length, predicted at actual lactation length and predicted to 270 days in milk (MY_{act} , PMY_{II} and PPY_{270} ; FY_{act} , PFY_{II} and PFY_{270} , and PY_{act} , PPY_{II} and PPY_{270} , respectively) for five breed groups and lactations of New Zealand dairy goats.....	105
Table 6.2. Concordance correlation coefficients (and standard errors) for five breed groups and five lactations for actual lactation length, predicted to lactation length and predicted to 270 days in milk for milk, fat and protein traits in New Zealand dairy goats.	106
Table 7.1. Number and percentage values of female animals in the general and milking does herd, dead and culling rate and liveweight per age group category.....	131
Table 7.2. Age group categories, number of milking does, milk (MY), fat (FY), protein (PY) and lactose (LY) yield, metabolisable energy (ME) and dry-matter intake (DMI) requirements per year per milking doe.....	133
Table 7.3. Survival analysis in the dairy goat herd using the Kaplan-Meier (1958) method.	133
Table 7.4. Range, frequencies and penalties for somatic cell count (SCC) and somatic cell score (SCS) ¹ levels in dairy goats.	137
Table 7.5. Price per kilogram of milk component and economic values for different payment system scenarios in dairy goats.....	138
Table 7.6. Sensitivity of economic values following changes in feed costs and milk-solids revenue by $\pm 15\%$ in the current scenario for New Zealand dairy goats.....	140
Table 8.1. Estimations of (Co) variances, genetic and phenotypic parameters (standard errors) for milk traits and somatic cell score in New Zealand dairy goats.....	157

Table 8.2. Heritabilities, repeatabilities, genetic and phenotypic correlations in goats for MY, FY, PY and SCS from different sources ¹	160
Table 9.1. Herd structure in the dairy goat herd.	174
Table 9.2. Selection index, breeding objectives and selection schemes in New Zealand dairy goats.	176
Table 9.3. Heritabilities, repeatabilities, genetic and phenotypic correlations for the traits in the breeding objective and selection index.	179
Table 9.4. Values or equations to estimate the weighting factors k_i for phenotypic variance or k_{ij} for phenotypic covariances according to selection scheme.	179
Table 9.5. Genetic gain for three selection schemes and four breeding objectives in New Zealand dairy goats.	187
Table 9.6. Genetic responses in traits in the breeding objective of the three selection schemes and four breeding objectives in New Zealand dairy goats.	188

LIST OF FIGURES

Figure 2.1. A systematic approach and enhancement of breeding programmes (Garrick 2005; Lopez-Villalobos & Garrick 2005).	8
Figure 4.1. Illustration with Wilmink model of use of random regression models to estimate individual lactation trait curves in milking does. In individual lactation curves ai, bi and ci are random regression deviations of the model parameters from the population lactation curve.	49
Figure 4.2. Lactation curves for milk, fat and protein yield curves (kg) for New Zealand dairy goats using four mathematical models.....	61
Figure 4.3. Individual milk, fat and protein yield curves (kg) for high and low yielding dairy goats producers using four mathematical models.....	62
Figure 5.1. Milk, fat and protein yield curves for five breed groups in New Zealand dairy goats.	85
Figure 5.2. Milk, fat and protein yield curves per lactation number in New Zealand dairy goats.	86
Figure 7.1. Herd dynamics and breeding in the dairy goat farm per year. The number of animals is presented in parenthesis.	134
Figure 7.2. Actual (MY) and predicted (PMY) milk yield for New Zealand dairy goats.	135
Figure 7.3. Actual (FY) and predicted (PFY) fat yield for New Zealand dairy goats.	135
Figure 7.4. Actual (PY) and predicted (PPY) protein yield for New Zealand dairy goats.	136
Figure 7.5. Actual (LW) and predicted (PLW) liveweight for New Zealand dairy goats.	136
Figure 7.6. Survival rate trend using Kaplan-Meier method in New Zealand dairy goats.	137
Figure 7.7. Factors accounted for in a dairy goat farm model to derive economic values.	139

Figure 9.1. Diagram for pedigree selection using one or three dam lactations to select replacement females or males in a dairy goat herd. 180

Figure 9.2. Progeny testing scheme (PT) within a New Zealand dairy goat herd. 181

Figure 10.1. Genetic gain in the current breeding objective for three selection schemes (progeny test, pedigree selection using one or three records on dam) for the New Zealand dairy Goat Cooperative assuming 100,000 milking does from 2010 to 2030..... 205

LIST OF APPENDICES

Appendix 4.1. Correlation matrices between the parameters ¹ of the four mathematical functions for milk, fat and protein yield in New Zealand dairy goats.....	69
Appendix 4.2. Regression coefficients (β_0 and β_1), Akaike information criteria (AIC), differences between AIC (Diff), odd ratio (OR) and Akaike weights (AW) for milk (MY), fat (FY) and protein (PY) yield traits using four mathematical models in New Zealand dairy goats.	70
Appendix 4.3. Number of typical and atypical lactation curves in the test-day data and lactations for milk, fat and protein yield using four mathematical models in New Zealand dairy goats.....	71
Appendix 5.1. Number of test-day records, number of milking does per breed group and per lactation number.....	91
Appendix 5.2. Least square means, standard errors and significance levels for model parameters of milk yield, fat yield and protein yield for 10 breed groups of New Zealand dairy goats.	93
Appendix 5.3. Milk, fat and protein yield curves for 10 breed groups of New Zealand dairy goats.	94
Appendix 5.4. Concordance correlation coefficients and significance levels for ten breed groups using the Wilmink model for milk, fat and protein yield of New Zealand dairy goats.	95
Appendix 6.1. Least square means and significance levels for milk (MY), fat (FY) and protein yield (PY) and standard errors in brackets, using the Wilmink mathematical model for 10 breed groups of New Zealand dairy goats.	111
Appendix 6.2. Concordance correlation coefficients (and standard errors) for ten breed groups for actual lactation length, predicted to lactation length and predicted to 270 days in milk for milk, fat and protein traits in New Zealand dairy goats.	112

Appendix 8.1. Heritabilities, repeatabilities and genetic and phenotypic correlations for some important traits in dairy goats ¹	163
Appendix 8.2. Heritabilities, genetic and phenotypic correlations for some economically important traits in dairy cattle ¹	166
Appendix 8.3. Heritabilities and genetic correlations in sheep for SCS with milk (MY), fat (FY) and protein (PY) yield traits in dairy goats.....	168
Appendix 9.1. Differences in genetic responses between selection schemes for the four breeding objectives in New Zealand dairy goats.	195
Appendix 9.2. Genetic and phenotypic covariances of the traits in the breeding objective before and after bending.	196

CHAPTER 1
INTRODUCTION

In New Zealand the environmental conditions are conducive for pasture production for most of the year and the various ruminant production systems are dominated by outdoor grazing. However, because of management advantages, for example to control goat parasites, most dairy goats are kept indoors, being fed a mixture of pasture and concentrates.

Since the dairy goat industry was established in New Zealand in the late 1970s and early 1980s it has sustained steady growth, mostly around the Waikato region. Most dairy goat farmers are organised as the Dairy Goat Cooperative, (NZ) Ltd (DGC) located at Hamilton where milk is made into milk powder and exported to several countries. Further plans of expansion to increase export growth to the European Union (EU) were announced in 2013. The proposed expansion occurred after DGC secured a ruling from the EU authority's panel on dietetic products, nutrition and allergies, that protein from goat milk is suitable as a protein source for infant formula.

In the absence of a national genetic improvement scheme for dairy goats, achieving and monitoring genetic gain is difficult. Implementing a genetic improvement scheme is an important part of the development and progress of the dairy goat industry in New Zealand to meet product demand in the longer term. For New Zealand dairy goats the breeding goal could be defined in terms of profit per milking doe, profit per hectare or profit per kilogram of dry-matter intake. To achieve the chosen breeding goal it is necessary to assemble a breeding objective which is the combination of breeding values and economic values of important traits affecting profitability. Information from the farming system and individual goat data are important inputs into the development of a farm model which enables the calculation of economic values.

Dairy animal genetic improvement programmes are typically multi-trait and include milk production traits (usually: milk, protein and fat yield), liveweight, fertility and health traits to improve efficiency, sustainability and profitability of the production system. To optimise overall genetic improvement these traits should be combined into a single index value representing the aggregate economic merit of an animal. This is achieved by combining evaluations on a portfolio of traits weighted by their economic values.

New Zealand dairy goat farmers would benefit from an improved description of goat production systems, the establishment of breeding objectives, prediction of lactation curves, estimation of genetic parameters and construction of breeding schemes. Completion of these tasks would enable the construction of a comprehensive genetic improvement programme to improve dairy goat farm profit.

The overarching objective of this thesis was to:

- Develop a genetic improvement programme for New Zealand dairy goats.

The specific objectives were to:

- 1) Review the literature on genetic improvement in dairy goats (Chapter 2).
- 2) Describe a typical dairy goat production system in the Waikato, New Zealand (Chapter 3).
- 3) Evaluate four different mathematical models using random regression models to predict lactation trait curves for New Zealand dairy goats (Chapter 4) and then estimate the production levels of milk, fat and protein yield for breed groups and parity number (Chapter 5 and 6).
- 4) Estimate economic values and genetic parameters for important traits affecting farm profit (Chapters 7 and 8).
- 5) Predict the genetic gain in selection schemes under different scenarios for New Zealand dairy goats (Chapter 9).

The final chapter (Chapter 10) discusses issues raised by this thesis and suggests future research that might be of value for the New Zealand dairy goat industry.

CHAPTER 2
A LITERATURE REVIEW ON SOME ASPECTS OF THE GENETIC
IMPROVEMENT OF DAIRY GOATS

INTRODUCTION

The dairy goat industry is recognised worldwide. Goat's milk has highly nutritive properties and is one of the most consumed milks. Goat milk could be consumed as liquid milk or processed to produce cheese, butter, yogurt, sweets, ice cream and a variety of cosmetic products (Solis-Ramirez & Mendoza-Moreno 2005). The yield of processed products largely depends on the level of milk-solids (Park et al. 2007).

An efficient and vigorous dairy goat industry will be aided by a comprehensive genetic improvement programme which increases efficient milk and milk-solids production. Genetic improvement programmes should aim to improve successive generations of animals that will produce desired products more efficiently under future farm economic, ecologic and social circumstances than the present generation of animals. In this way, the rational use of dairy goat genetic resources and their improvement for commercial purposes requires the design of a breeding programme. Harris et al. (1984) presented a procedure for arranging choices, decisions and other relevant information to develop a breeding programme. Garrick (2005) schematically summarised these steps and discussed their use in the design and enhancement of breeding programs of any livestock enterprise (Figure 2.1). These steps are closely related and systematically organised to achieve the farmers goal.

The goal or breeding goal is a statement of the direction of the genetic improvement programme, for example profit per milking doe, profit per hectare or profit per kg of dry matter consumed. The breeding objective can be considered the tool to achieve the breeding goal and is one of the most critical aspects of a genetic improvement programme. The breeding objective is the list of important traits affecting profit represented in a mathematical form based on sound economic principles. The breeding objective should be used in conjunction with predictions of genetic merit for objective traits to rank animals within a breeding population (Kluyts et al. 2003). The breeding objective and phenotypic traits (e.g. herd test measurements) measured in the population are the key points to construct selection criteria or a selection index to select the best animals to reach the breeding goal.

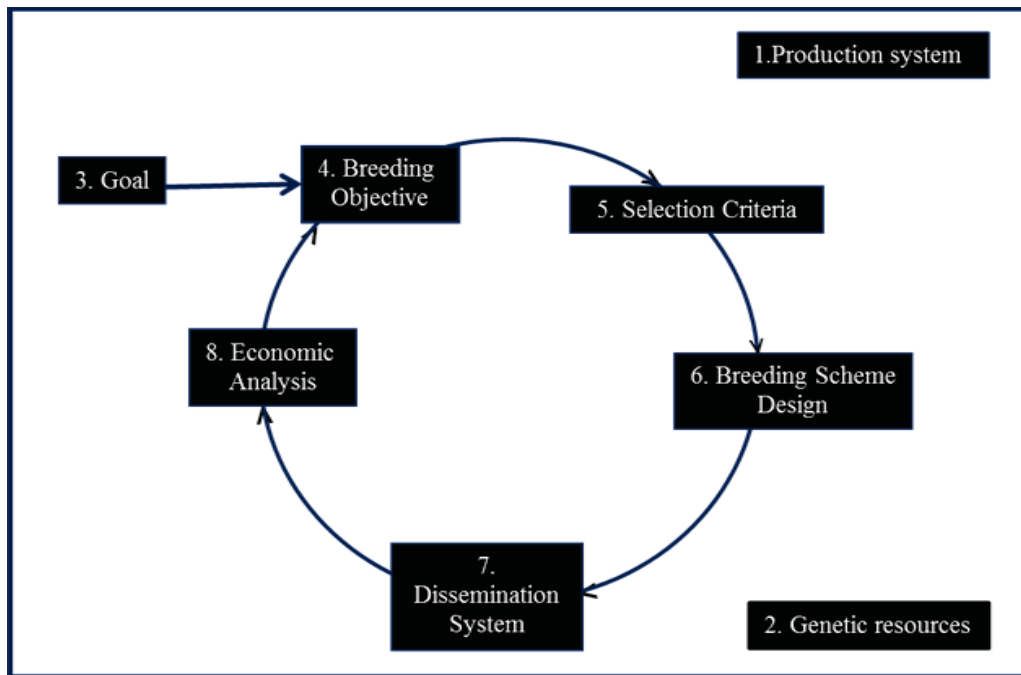

Figure 2.1. A systematic approach and enhancement of breeding programmes (Garrick 2005; Lopez-Villalobos & Garrick 2005).

Despite there being few genetic improvement programmes worldwide, selection and crossbreeding methodologies have expanded the role of goats and improved production levels around the world (Devendra & Burns 1983; FAO 2007, 2010b; Gall 1981; Haenlein 2001). Selection or crossbreeding or both should lead to producers having a more appropriate animal genotype that matches farmer expectations of production, adaptability, efficiency, feed resources, markets and profit. The selection of the top genetic quality animals in accordance with farm objectives and expectations is imperative when choosing parents of the next generation (Newman et al. 1992). The most suitable combination of genes in an animal when combined with environmental factors will lead to successful outcomes on farms for livestock enterprises.

Harris (1970) pointed out that when animal characteristics are easily measured, progress is largely dependent on the effective utilisation of additive genetic variance, accurate identification of traits, accurate estimates of genetic parameters and appropriate economic weighting factors for each trait in accordance with their importance. The maximisation of profit should be the most important breeding goal, and in this case, the breeding objective should account for inputs and costs as

well as outputs and revenue (Kluyts et al. 2003; Ponzoni 1986). However, methods applied to increase goat milk production, both within- and across-breed performance groups, are not well documented. The recent use of techniques such as genomic selection will likely help to increase the accuracy of identification of high genetic merit animals and decrease the generation interval thereby increasing the rate of genetic gain per year (Carta et al. 2009; Hayes 2007). However, the successful implementation of genomic selection in many dairy industries will be hampered by poor recording keeping.

An example of a well-defined breeding objective is in the breeding programme of New Zealand Dairy Cattle (Harris 1998; Lopez-Villalobos & Garrick 2005). This breeding objective combines breeding values for milk yield, fat yield, protein yield, liveweight, fertility, somatic cell count and longevity with the economic importance of each trait for farm profitability. In contrast, a breeding objective has not yet been defined for New Zealand dairy goats and it seems that optimal breeding objectives are also absent in many other countries (Bett et al. 2011; Kosgey et al. 2006; Kosgey et al. 2008).

This review will examine some aspects related to the implementation of a comprehensive genetic improvement programme for New Zealand dairy goats.

BREEDING GOALS AND OBJECTIVES

The starting point of a comprehensive genetic improvement programme for a specific production system is the definition of the breeding goal and breeding objective (Charfeddine 2000; Fewson 1993; Grasser et al. 2006; Groen et al. 1997; Harris 1970; Harris et al. 1984; Lopez-Villalobos & Garrick 2005; Newman et al. 1992; Ponzoni 1986; Ponzoni & Newman 1989a; Tozer & Stokes 2002). The breeding goal is a statement of the desired direction of the genetic improvement programme. The most common breeding goal of modern genetic improvement programmes is to increase profit per animal or per unit of feed consumed (Charfeddine 2000; Fewson 1993; Grasser et al. 2006; Groen et al. 1997; Harris 1970; Harris et al. 1984; Lopez-Villalobos & Garrick 2005; Newman et al. 1992; Ponzoni 1986; Ponzoni & Newman 1989b; Smith 1983; Tozer & Stokes 2002).

Profit per animal is a measure of individual efficiency, whereas profit per unit of feed consumed is a measure of feed utilisation per group of animals.

The breeding objective is defined as a combination of breeding values and economic values of important traits affecting profitability to meet the breeding goal (Charfeddine 2000; Grasser et al. 2006; Groen 2000; Harris et al. 1984; Lopez-Villalobos & Garrick 2005; Newman et al. 1992; Ponzoni 1986). An inaccurate definition of the breeding objective will undermine the effectiveness of the overall genetic improvement programme and either genetic progress will not be optimal or in the worst case scenario it may lead to economic deterioration of the population (James 1982). Two important principles should be considered in listing the traits in the breeding objective. First, the choice should be based purely on economic grounds and secondly, all economically important traits should be considered (Gjedrem 1972; James 1982). Defining a breeding objective enables calculation of the economic benefits from a breeding programme. This involves many disciplinary experts in the manufacturing and production sectors of the industry as well as economists and animal breeders.

Breeding objectives can be defined either in terms of biological efficiency or economic efficiency. The biological measure takes little account of the relative food costs and product quality and is expressed in energy or protein terms. Biological efficiency is not ideal because not all costs and revenue can be expressed in terms of energy and/or protein (Groen 1989a). In contrast, economic efficiency accounts for the differences in unit prices of food and animal products and is expressed in monetary units and is most commonly used in the estimation of animal efficiency and modeling of genetic improvement schemes (Groen 1989b).

Breeding objectives can be expressed based on per progeny, per animal, per herd or per hectare but this may be problematic due to constraints in different sections or tiers in the industry (Harris 1970; Moav & Moav 1966; VanVleck 1964). The animal breeders primary unit of selection is usually the individual animal and it has been argued that the breeding objective should be expressed on a per animal basis. Dickerson (1970) also suggested the use of expense and production per female per year in formulating a breeding objective, a recent example of this approach for New Zealand dairy goats was published (Solis-Ramirez et al. 2012). An alternative

approach was taken by the New Zealand dairy cattle improvement programme which expressed the breeding objective in profit per 4.5 tonnes of dry-matter intake (Lopez-Villalobos 1998).

The breeding objective generally includes more than one trait, which implies simultaneous selection for several traits most likely using selection index methodology. Regardless the name of the breeding objective (economic goal, net merit, economic efficiency or aggregate breeding value), the objective is to achieve maximum genetic progress toward a clear breeding goal (Dekkers 1991; Dickerson 1970; Du Plessis & Roux 1999; Harris 1993; Kluyts et al. 2003; Weigel et al. 1995; Wilton et al. 1998). The breeding objective is seldom fully implemented in livestock breeding industries (Harris & Newman 1994), but when it is fully implemented, it reflects the combination of different aspects of the production system and production efficiency (Harris et al. 1984; James 1982; James 1986).

Selection index theory developed by Hazel (1943b) defined the breeding objective as the aggregate genotype consisting of a linear function of breeding values of the traits to be improved, each multiplied by its economic value, as follows:

$$T = EV_1 \times BV_1 + EV_2 \times BV_2 + EV_3 \times BV_3 + \dots + EV_n \times BV_n \text{ then,}$$

$$T = \sum_{i=1}^n EV_i \times BV_i$$

where:

T = the breeding objective,

EV_i = the economic values of the *i*th trait (*i*=1, 2,...,n), and

BV_i = the breeding value of the *i*th trait (*i*=1, 2,...,n).

Modern genetic improvement programmes use costs and revenue from the production system to estimate profit as total revenue minus total costs of production. This enables the estimation of economic values (EVs) for each trait in the objective, which according to Hazel (1943b) is the amount by which net profit increases for each unit of improvement in a trait while holding other traits constant.

DEVELOPMENT OF BREEDING OBJECTIVES

Few breeding objectives have been published for dairy goats worldwide (Bett et al. 2007a; Bett et al. 2011; Gaviña 2000; Lopes et al. 2012). However, many papers have been published on the development of breeding objectives in dairy and beef cattle and sheep. Harris et al. (1984); Ponzoni (1986), Ponzoni & Newman (1989a), Gibson (2005), Lopez-Villalobos & Garrick (2005), and Grasser et al. (2006) have all explained the sequential steps in developing a breeding objective. While varying somewhat depending on the author, the steps can be summarised as follows:

- 1) Specification of breeding, production and marketing systems,
- 2) Identification of sources of income and expense;
- 3) Determination of biological traits influencing income and expenses, and
- 4) Derivation of economic values for important traits identified.

Specification of breeding, production and marketing systems

The collection of reliable information regarding the breeding, production and marketing system is an important first step in accurately defining the breeding objective. One approach is to survey farmers. The survey should include questions that cover all aspects of the farming system such as the herd structure, the breeding system, the production and marketing system, general farm management as well as the payment system set by the milk processing company. The survey should establish the reasons for keeping dairy goats, understand the production constraints, determine the relative importance of both physical and socio-economic benefits to farmers, traits of economic importance, understand the dairy goats attributes that farmers consider to be of fundamental importance, and to know if any genetic improvement programme has been applied to the dairy goat population (Kosgey et al. 2008; Solis-Ramirez et al. 2011).

A description of the breeding system also involves defining whether the animals are to be purebred or crossbred because this will influence the economic values of traits (Dickerson 1970). Goat breeds like Saanen have been selected for milk volume, but others like Boer have been selected mainly for meat and others for multiple

purposes e.g. Nubia, Murciano-Granadina or Creole goats (Bett et al. 2007a; Fernández et al. 2002). Most of these breeds can be found in crossbred herds for multiple purpose use.

The production and marketing system explains how animals are fed and managed, the age composition of the herd, the replacement policy, longevity, and ages of slaughter animals (Ponzoni & Newman 1989a). The type of feed (roughage or concentrate) and pattern of feeding such as stall feeding or feeding on pasture, should be included in the description of the feeding system. In temperate regions such as New Zealand the main source of feed is pasture. In this situation, the cost of grass, length of the grazing period, length of the intensive feeding period (supplements), run-off, and the cost of the supplements should be specified. Most often for the purpose of establishing a breeding objective it is assumed that the total amount of feed remains constant. This is a justifiable constraint for a producer who wishes to maintain a constant grazing pressure on the farm because an increase in grazing pressure could lead to pasture deterioration and a decrease would result in under-utilisation of feed (James 1982; Ponzoni & Gifford 1990).

The important aspects of the life cycle of production animals, such as age at weaning, breeding age and interval between offspring production, need to be specified. The nature of primary products (e.g. milk and milk-solids contents for dairy goats) and secondary products (e.g. meat, manure and skin in case of dairy goats) and their purposes also need to be fully described. The numerical distribution of the herd, number of replacements per year, number of animals available for marketing in a year and the normal life cycle of parents need to be detailed (Ponzoni 1988). This information is required for calculating the economic values (EVs), as not all traits are expressed with the same frequency nor at the same time (Ponzoni & Gifford 1990).

The marketing system that aligns with the production system and the opportunities for national or international sales should be taken into account. The scope of marketing is very wide and has a major impact on the development of breeding objectives, and therefore breeders and producers should respond to both current and predicted market movements. The variation and movements due to offer and demand in market products can affect EVs much more than other changes in the

breeding objective (Stewart et al. 1986). Tied in with the EVs is the payment system which will determine where the selection emphasis will be placed. For example, transformation of liquid goat milk into powder goat milk for exportation should incentivise high milk-solids content (i.e. high protein or high fat content).

Identification of sources of income and expense

Identification of sources of income and expenses enables the development of a profit equation and calculation of EVs in animals, e.g. in dairy goats (Bett et al. 2011; Lopes et al. 2012; Solis-Ramirez et al. 2012). Total costs, expenses or inputs can be divided into two categories, namely fixed and variable costs. Fixed costs are those incurred by the producer, such as interest and insurance which are independent of production level and the variable costs are those which vary with the level of herd production (Newman et al. 1992). Variable costs or inputs for the production systems are feed (e.g.: roughage or concentrates), management (e.g.: labour, administration, spraying or dipping, veterinary services, and mineral supplements) and marketing (for example: transport of live animals and carcass, and levies for auction, slaughter and meat inspection).

Farm income can be divided into primary and secondary sources. For most livestock farming systems, the primary sources of income are milk and milk-solids, fibre, meat, surplus offspring and culled animals. Returns on primary products depend both on quantity and quality of the product. For example, returns from dairy goats depend not only on milk yield, but also on the milk's composition which, determines the total solids production (Ricoardeau 1981). In most systems income from culled animals is influenced by the weight of each animal and by the price per unit weight in each age class. Returns from the sale of secondary products in the goat industry are generally products like manure and skin (Kosgey et al. 2003).

In animal production systems, feed costs represent the major percentage of total costs and contribute significantly to the efficiency of animal production (Harris & Newman 1994). In systems of organised goat milk production, feeding represents 50-80% of the total costs (Morand-Fehr et al. 1992). The significance of accounting for changes in the feed costs of genetically improved animals was considered by Ponzoni (1988). James (1982) stressed the importance of including feed intake as a

trait in the breeding objective. If feed intake could be properly accounted for in the breeding objective, concerns over per animal versus per unit of land objectives would be effectively eliminated. Garrick (2002) described a way of taking into account feed intake cost in the definition of the breeding objective for dairy cattle when feed cost as a trait was explicitly accounted for and an economic value estimated for feed intake. He contrasted this to when feed costs were not explicitly included and the costs were distributed over other traits and accounted for indirectly in the EVs for those traits. Lopez-Villalobos & Garrick (2003) showed that the genetic outcomes are the same when feed cost were included into other traits in the breeding objective (e.g. milk yield, protein yield and fat yield) compared to when the EVs for feed were explicitly calculated and included in the breeding objective.

Determination of biological traits influencing income and expense

The traits to be included in the breeding objective should be related as directly as possible to sources of income and costs (Harris & Newman 1994; Lal 1982; Ponzoni 1986). Lal (1982) pointed out that in dairy goat farming, important traits affecting sources of income and expense are live weight, milk yield, composition of milk and reproductive performance. More recently other traits have been incorporated such as survival rate and somatic cell score (functional traits) (Bett et al. 2012a; Lopes et al. 2012). In a recent study on New Zealand dairy goat production conditions (Solis-Ramirez et al. 2012) showed that milk, fat, protein and lactose yield (MY, FY, PY and LY, respectively) and liveweight (LW) should be taken into account for the breeding objective when the main production purpose is milk-solids production.

Once the productive and functional traits affecting income and expense are identified and the definitive list for inclusion in the breeding objective is prepared, a profit equation reflecting the breeding objective should be expressed as a function of those traits (Jones 1982; Ponzoni 1986). The profit function should be as close to the true profit as possible. Traits should not be left out because information about them is lacking, but they can be excluded if there is no genetic variation in them. Profit functions that leave out important traits can lead to suboptimal benefits from selection schemes.

In some instances, justification for inclusion of a trait in the breeding objective may be immediately obvious but for some other traits it may not (Ponzoni & Newman 1989a). The objective may be little affected by the inclusion of traits which account for only a small proportion of profit at the genetic level. For example, when the product of the economic value of a trait and its genetic standard deviation is trivial, failure to account for the income and expense from that trait may be virtually of no consequence (Barwick & Fuchs 1992). Thus, determining the important biological traits associated with each source of income and expense is a crucial step in developing a breeding objective.

Derivation of economic values for important traits

Hazel (1943b), who first applied a multi-trait selection index to animals, defined the EV of a trait as the amount by which net profit may be expected to increase for each unit of improvement in that trait while holding other traits constant. There are three ways to express economic values. The term economic value was already defined by Hazel (1943a). The relative economic value (REV) refers to an EV expressed relative to other trait EV (Barwick 1992) or to the total of the EVs of the traits in the breeding objective (Harris 1993). The third term is the relative economic weight (REW) which is defined similarly to REV but expressed in genetic standard deviations.

Methods for calculation of EVs have been discussed by Smith et al. (1986), Charfeddine (2000), Kluyts et al.(2003), Kuprova et al. (2008). There are subjective (non-objective) and objective methods to derive economic values. Subjective methods do not derive economic values by direct calculation of influences of improvement of a trait on the increase in efficiency of the production system. Rather they rely on assessments based on points of view and data from skill and empirical experiences gained by familiarity with the production system. A major justification for this method is insufficient knowledge to model relevant aspects involved. Specific non-objective methods are those used to establish desired or restricted genetic gain indexes. These methods assign relative economic values in order to achieve a desired or restricted amount of genetic change for some traits. Subjective methods have been criticised in several papers for lack of accuracy and variable outputs (Gibson & Kennedy 1990; Groen et al. 1994).

Charfeddine (2000) and Kuprova et al. (2008) explained that objective methods use quantitative methods to numerically assess the economic value. The principal tool used in objective methods is modeling, but a partial derivative approach has also been used. The partial derivative approach estimates the economic value of a trait as the partial derivative of the profit function with respect to each of the traits affecting profit, for example, the first partial derivative of a function y , with respect to the variable x , is dx/dy . It is the slope of the line at the point (x,y) . This approach has been used in dairy (goats and cattle), meat and wool production species (Kluyts et al. 2003; Ramón et al. 2010; Van Arendonk & Branscamp 1990; Wolfová et al. 2009a).

The modeling approach requires the definition of an equation or a set of equations that represents the behaviour of a system, such as a dairy goat farming system. Two approaches to systems analysis can be described, a positive or data evaluation approach and a normative or data simulation method (James & Ellis 1979). These methods have since been named data analysis (positive) and bio-economic modeling (normative) (Van Arendonk & Branscamp 1990). When applying data analysis, observed economic and technical data and historical prices, are used to derive the economic importance of animal traits. A regression approach using genetic variances can be helpful to predict profit. Two terms are used to describe profit simulation models, profit models and bio-economical models. The profit function is a single equation and the bio-economical or efficiency models could be more appropriate than a profit model. A multi-equation simulation model is referred to as a bio-economic model. Simulation models help to derive the economic values by studying their reaction to a change in production factors related to the genetic merit of the animal for a specific trait, without changing other traits. A data simulation approach provides more possibilities of applying different prices, production levels and scale of farming than the profit (efficiency) functions. Estimates of EVs for traits in breeding objectives for dairy and beef cattle, pigs, poultry and sheep have been published by many authors (Groen et al. 1994; James 1982; Kluyts et al. 2007; Ponzoni 1986; Smith et al. 1986; Van Arendonk & Branscamp 1990).

Ponzoni (1986) working with Merino sheep in Australia suggested that the derivation of economic values should include a discounting technique. This

technique accounts for the differential expression of the traits in the breeding objective that are expressed neither with the same frequency nor at the same time. In order to account for this fact, two approaches have been used: firstly, calculation of all income and expenses in one year (which accounts for frequency but not for time lag) for a given herd composition, and secondly, using the “discounted gene flow” method of McClintock & Cunningham (1974), which accounts for both frequency and time lag.

The discount factor accounts for the fact that economic benefit at the present is more valuable than economic benefit in the future. Therefore, traits expressed sooner after selection should receive more emphasis than traits expressed later in the life. Since the discounted gene flow method takes into account both the frequency and the time of expression of traits, it should be the preferred method used in the estimation of economic values (Ponzoni & Newman 1989a). Commonly a 10 % discounting has been used as the basis for comparison of alternative selection procedures (Newman et al. 1992). This closely reflects the average international interest rate. Ignoring cumulative discounted expressions in animal breeding goals will lead to bias in relative selection emphasis on traits and to non-optimal genetic responses (Charfeddine 2000).

DEFINITION OF BREEDING OBJECTIVES

Research on genetic evaluation and breeding objectives is more abundant for meat goats (Campbell & Waldron 2006; Haenlein 2001; Iloeje & Van Vleck 1978; Naude & Hofmeyr 1981; Otuma & Osakwe 2008; Shrestha & Fahmy 2005, 2007b, a) than for milk goats (Barillet 2007; Gall 1981; Haenlein 2001; Iloeje & Van Vleck 1978; Lopes et al. 2012; Solis-Ramirez et al. 2012). Comprehensive goat genetic improvement programmes for both meat and milk goats are very limited around the world with only a few countries, such as France and Spain, working on this area of research. Therefore, scientific reports of breeding objectives in dairy goats are still very limited. In part, this may be a reflection on the current state of world goat populations, with the greatest number of animals being in developing countries (Azis 2010; Dubeuf & Boyazoglu 2009; FAO 2010b). However, important advances in milk production due to increases in production per animal or

increases in population or herd size have been reported from several countries (Azis 2010; Dubeuf & Boyazoglu 2009; Haenlein 2001; Lindsay & Skerrit 2003).

There are few studies on the development of breeding objectives in dual purpose or dairy goats (Bett et al. 2007a; Bett et al. 2009b; Bett et al. 2011; Lopes et al. 2012). From the commercial point of view, the European dairy goat production systems are the most sophisticated and they include milk yield, fat and protein yield in their breeding objective (Azis 2010; Dubeuf & Boyazoglu 2009; Lindsay & Skerrit 2003). In Kenya, where the small ruminant industries play an important role in the economy and social life of Kenian society, Kosgey & Okeyo (2007) and Bett et al. (2007a; 2009b; 2009a; 2011) have published important papers on the current situation of the production systems, breeding practices, farm model development and breeding objectives for sheep and goats. Bett et al (2011) pointed out that not all traits in a breed in a small production system should receive the same emphasis when defining a breeding objective due to the different roles of the traits in the different systems. They state that traits like daily milk yield, average daily gain, number of kids weaned and 12-months liveweight are important to increase profit, while an increase in mature weight did not impact on the profitability of the system. Bett et al. (2011) also suggested the incorporation of risk in the estimation of economic values in goats when information comes from farmers, due to variability of profit and farmers attitude. However, when there are small differences in profit due to low fluctuations across years (which means smaller uncertainty), simple profit equations can satisfactorily be used to predict profitability.

SELECTION CRITERIA

The potential for genetic improvement is largely dependent on the magnitude of the genetic parameters of the trait (heritability and repeatability) and the genetic relationship between traits (genetic correlation) of economic importance upon which selection pressure is applied. Heritabilities are essential for planning efficient breeding programmes, and for predicting responses to selection. Information from repeatabilities can be useful either in the structure of selection indexes or to predict production ability for future records. Genetic correlations help to predict correlated responses in other important traits affecting profit in the herd. Definition and methods of estimation of genetic parameters are widely reported in the literature

(Bourdon 2000; Falconer & Mackey 1996). Estimates of genetic parameters in dairy goats are not abundant, however estimations for a variety of production and functional traits can be found in the literature (Analla et al. 1996; Bett et al. 2012a; Boichard et al. 1989; Lopez-Villalobos & Garrick 2001; Menéndez-Buxadera et al. 2010; Montaldo et al. 2010; Morris et al. 2011; Rupp et al. 2011).

Estimates of genetic parameters in dairy goats for productive and functional traits are presented in Table 2.1. Briefly, heritability values for MY, FY, PY, LY were variable and ranged from 0.04 to 0.72; while for mature LW the range was from 0.18 to 0.79 and for somatic cell score (SCS) the range was from 0.15 to 0.24. Repeatabilities for MY, FY, PY and LY traits ranged from 0.27 to 0.61 and genetic and phenotypic correlations estimates ranged from -0.04 to 0.98, with a higher frequency for positive estimations.

Each selection criterion should be developed as an appropriately weighted mathematical function of the relevant direct and indicator traits of individuals and near relatives. An optimum selection index should be used in preference to simpler criteria (Harris et al. 1984). The most pertinent basis for deciding among selection criteria is to choose those that will optimise selection response at that specific point in the life cycle, accounting for costs and revenue. The decisions are highly dependent, therefore, upon the reliability of the predicted response. This reliability, in turn, is dependent upon the accuracy of the parameter estimates and their specificity for the breed or strain being selected.

LACTATION TRAIT CURVES IN DAIRY GOATS

Dairy animal genetic improvement programmes are based primarily on milk yield, milk composition traits and on other traits related to milking performance. Milk production in mammals is represented by a non-linear curve. Milk production starts after parturition and continues until the end of milk production caused by either the biological end of milk synthesis or management practices.

The shape of the lactation curve and factors affecting the curve (e.g. breed, lactation and season) are of interest to assist with the evaluation of the biological and economic efficiency of breeds, generations, groups of animals or individual production. This helps farmers and breeders making management decisions such as

feeding, mating and culling. Knowledge of the lactation curve also helps with estimating the total lactation yield from test-day-records, and forecasting herd performance on a time or individual animal basis (Sauvant 1988).

Important aspects of a typical lactation curve are initial production, ascending phase, maximum production point and persistence under a standard dairy farm production system (Wood 1967). It is influenced by the growth and death of cells in the mammary gland during pregnancy and lactation (Dijkstra et al. 1997). Maximum development of the mammary gland, concomitantly with body size, is usually reached at 3-4 years old in ruminants.

The publication of Wood's incomplete gamma function (Wood 1967) to predict the lactation curve led to an increased number of investigations in this area. These studies included the application of alternative non-linear models and the use of sophisticated and powerful software to fit and describe lactation curves in different environments and for different breed groups (Ali & Schaeffer 1987; Grossman & Koops 1988; Macciotta et al. 2005; Wilmink 1987a). The models developed are also useful in the genetic analysis of test-day records to account for the effect of lactation stage (Ptak et al. 1993) and to model the covariance between test-day records in a random regression analysis (Jamrozik & Schaeffer 2010).

There are numerous reports on the use of mathematical models to describe lactation curves in dairy cattle (Khan 2009; Liu et al. 2006; Macciotta et al. 2004; Silvestre et al. 2009), but in dairy goats, modelling of lactation curves is poorly studied (Gipson & Grossman 1989a, 1990; Macciotta et al. 2008). Gipson & Grossman (1990) examined several mathematical models (the general exponential model, the inverse polynomial, the grafted polynomial and the multiphasic model) but none have been widely used in the dairy goat industry. Some studies in dairy goats reported that the Wood model adequately described the lactation curve (Fernández et al. 2002; Montaldo et al. 1997; Ruvuna et al. 1995), but other studies reported that Ali & Schaeffer and Legendre models fitted better (González-Peña et al. 2012). These results suggest an inconsistency in the way in which the mathematical models react to different environmental conditions, goat breeds or indeed other factors. Therefore, further studies are needed to identify the best mathematical models to describe the lactation curve for different breed groups or farm conditions.

Table 2.1. Heritabilities, repeatabilities, genetic and phenotypic correlations in goats for milk, fat and protein yield from different sources¹.

Trait	Traits					Reference
	MY	FY	PY	SCS	t_i^2	
MY	0.25	0.81	0.93		0.42	Lopez Villalobos & Garrick (2001)
	0.18	-0.48	-0.47		0.39	Analla et al. (1996)
	0.17					Torres-Vazquez et al. (2009)
	0.23				0.26	Morris et al.(1997)
	0.34				0.52	Morris et al.(2006)
	0.39			-0.21	0.52	Morris et al.(2011)
	0.28				0.56	Zumbach et al. (2008)
	0.30 to 0.34					Rupp et at. (2011)
	0.28 to 0.72					Boichard et al. (1989)
	0.24					Rabasco et al. (1993)
	0.19 to 0.22				0.33 to 0.41	Menedez-Buxadera et al. (2010)
	0.22				0.40	Valencia et al. (2007)
	0.37				0.52	Tholon et al. (2001b)
	0.20					Breznik et al. (2000)
FY	0.90	0.24	0.88		0.41	Lopez Villalobos & Garrick (2001)
		0.36		-0.24	0.48	Morris et al. (2011)
		0.19				Torres-Vazquez et al. (2009)
		0.20				Rabasco et al.(1993)
	-0.02 to 0.13	0.35 to 0.32				Rupp et at. (2011)
	0.52 to 0.93	0.22 to 0.64				Boichard et al. (1989)
	-0.89 to 0.86	0.16	0.54		0.36	Analla et al. (1996)
		0.18			0.35	Lopes et al. (2012)
						Menedez-Buxadera et al. (2010)
PY	0.96	0.92	0.25		0.42	Lopez Villalobos & Garrick (2001)
			0.41	-0.18	0.54	Morris et al. (2011)
	-0.65	0.93	0.25		0.47	Analla et al. (1996)
			0.04			Rabasco et al. (1993)
	0.86 to 0.95	0.78 to 0.94	0.42 to 0.59			Boichard et al. (1989)
			0.17			Torres-Vazquez et al. (2009)
	-0.04 to 0.06		0.34 to 0.31			Rupp et at. (2011)
	0.96					Lopes et al. (2012)

...continuation Table 2.1.

SCS				0.19	0.53	Apodaca et al. (2009)
	-0.01	-0.12	-0.05	0.20	0.37	Morris et al. (2011)
				0.15		Bett et al. (2012a)
	0.00 to			0.20		Rupp et al. (2011)
	0.12			to		
				0.24		

¹Heritabilities are on the diagonal (bold), genetic correlations are below the diagonal (right of the diagonal) and phenotypic correlations above the diagonal (to the left of the diagonal). ² t_i is repeatability. ³MY, FY, PY and SCS are milk yield, fat yield, protein yield and somatic cell score, respectively.

Selection of the best mathematical model for particular conditions should be based on some objective measure of the best fit of an idealised lactation curve to the raw data. Several “best fit” statistics have been used to select a model, for example, the coefficient of correlation, the concordance correlation coefficient, the means square prediction error, the Akaike information criteria and the Bayesian information criteria (Khan 2009; Val-Arreola et al. 2004).

Until recently, modelling of lactation curves has required a minimum number of test-day records (TDR) to enable a sufficiently accurate description of the lactation curve. However, random regression models (RRM) allow the estimation of curve parameters for each animal using one or more TDR. This allows the detection of differences in regression coefficients between animals and within animals over a period of time (Kirkpatrick et al. 1990; Kirkpatrick et al. 1994). Individual random regression coefficients make it possible to adjust the parameters for sources of variation affecting the parameter values and to calculate milk, fat and protein curves based on one or more TDR per animal (Schaeffer, 2004). While there has been wide use of RRM in dairy cattle (Buttchereit et al. 2010; Schaeffer et al. 2000; Schaeffer 2004), there are no publications for dairy goats.

In conclusion, there is need for a comprehensive study of which non-linear mathematical functions best describes dairy goat lactation curves. It is possible that different models will be better suited to various breeds and/or different parities.

GENETIC IMPROVEMENT PROGRAMMES

Selection of parents is one of the most important aspects in population genetic improvement and helps to identify and use the very high performance individuals for specific mating plans of any marketing or biological demand. In this step, the breeder needs to decide how to reproduce from the selected males and females for producing the next generation of animals. These decisions affect the intensity of selection, the accuracy of selection (the correlation between selection criterion and selection objective) and the generation interval, which collectively dictate the rate of change achieved from the additive genetic variability present within the breed or strain. The accuracies are determined, and maximised, by the selection criteria decisions. Selection for genetic improvement is a directional process whereby only a top portion of the population is allowed to reproduce. If the selected individuals are genetically superior to the population mean for a trait, then the average of their progeny will perform above the mean for that trait compared to the previous generation.

Many particular circumstances like region, production system, particular requirements of an industry, feed consumption variation, feed costs, education level of stock holders, herd size and price changes can affect the definition of a breeding goal and a breeding objective (Kluyts et al. 2003; Kosgey et al. 2003). These factors should be taken into consideration when defining the genetic improvement programme that best suits the local or international requirements.

The simplest and most direct way of ranking breeding animals is by individual selection based on their own phenotype and mating the chosen ones at random (Rendel & Robertson 1950). Other selection schemes can also be used for example, pedigree selection and progeny testing. Pedigree selection refers to the use of relative performance records of an individual to take selection decisions, for example, selection of a replacement milking doe or a young buck based on the average of dam records. Pedigree selection should be of practical use if selection decisions are to be made at as young an age as possible. However care should be taken since the rate of genetic gain can be compromised as a consequence of low selection accuracy and long generation interval if selection is based on an average of several records. Progeny testing uses the average of several progeny records to

evaluate the individual, generally a male (buck) (Bourdon 2000). Progeny testing increases the accuracy of selection, but increases generation interval. Progeny test is a selection scheme that can effectively be operated on a single farm basis if a planned farm strategy of facilities, number of animals, data keeping, recording and data analysis can be performed. However the integration of farmers through higher level organizations can help to get a stronger progeny test thus achieving greater genetic progress, reducing costs of implementing the progeny test and significantly increasing the intensity of selection.

Different tools and knowledge have been developed to aid selection for economically important traits. Some of these traits can be of low heritability (e.g. litter size, fertility), measured on one sex (e.g. conception rate or milk yield), measured late in life (e.g. longevity) or after slaughter (e.g. carcass weight). Use of several records, progeny testing, population size, high performance computing power, statistical developments, reproductive technologies (e.g. artificial insemination, multiple ovulation and embryo transfer schemes and sexed semen) and developments in molecular genetics (e.g. genomic selection) ensure the selection of genetically superior animals for any given economically important trait (Hayes 2007).

Similar to the case for breeding objectives, there are only a few studies on the development of comprehensive genetic improvement programmes for dairy goats with most of them being located in European countries. The French programme is based on the Index Combine Caprine which not only includes milk yield, but also quantity and percentage values of protein and fat (Lindsay & Skeritt 2003). Information from parents and grandparents of the animal are included and males are progeny tested. This programme unifies all breeds and focuses on the improvement of the economic value of the animals through genetics. This is achieved by keeping pedigree data, having a herd recording scheme, using artificial insemination and by estimating breeding values from the animal's own performance and all of its recorded female relatives (Dubeuf & Boyazoglu 2009; Lindsay & Skeritt 2003). The Spanish genetic improvement programme for milk production started in 1990 but was changed to protein and fat content improvement from the middle 90's (Analla et al. 1995; Analla et al. 1996; Azis 2010). The Murciano-Granadina

Association located in Granada developed a programme named CAPRIGRAM, which uses BLUP Animal Model genetic evaluations which are published in the yearly Catalogue of Sires (Camacho 2009).

New DNA-based technologies (e.g. genomic selection) have been greeted with scientific enthusiasm (Georges & Massey, 1991; Cockett, 1999; Meuwissen, 2003; Crawford, 2003; Deckkers, 2004; Garrick & Snell, 2005; Deckkers, 2007; Goddard & Hayes, 2007) and different degrees of success have been documented recently in dairy and beef cattle, swine and poultry (Van Eenennaam et al. 2014), which indicates that their commercial use is still limited and some considerations related to economics, optimal size of training population, cost-effective genotyping strategies, practicability of field implementation and the cost benefit ratio should be taken into account (CRV 2012; Hayes 2007; Van Eenennaam et al. 2014). However, it is expected that as soon as these considerations are sorted out, mainly the low-cost DNA technology, more countries will use it to increase the efficiency of animal genetic improvement.

Genomic selection (GS) uses genetic markers to identify specific regions of chromosomes where genes affecting quantitative traits are located (Davis & DeNise 1998). GS is a form of Marker Assisted Selection in which genetic markers covering the whole genome are used to identify QTL in linkage disequilibrium (non-random association of alleles at two or more loci in the same or different chromosome) with at least one marker (Goddard & Hayes 2007). The genotypic information provided by DNA analysis should help to improve the accuracy of selection and increase the rate of genetic progress by identifying animals carrying desirable genetic variants for a given trait at an earlier age (Van Eenennaam, 2014). Single nucleotide polymorphism (SNP) is the variation in the sequence of bases in the DNA of each individual (Garrick & Snell 2005). They are an abundant source of sequence variants that can be targeted for molecular marker development. Of all the molecular marker technologies available today, SNPs provide the greatest marker density. SNPs are often the only option for finding markers very near or within a gene of interest, and can even be used to detect a known functional nucleotide polymorphism. Implementation of a genomic selection scheme on a single farm basis is more difficult than a progeny test due to the highly specialised facilities and labour required. This genomic selection scheme is only possible if a

higher level of integration is reached by farmers into a private company, a dairy goat cooperative or a government department. The implementation of a genomic selection scheme can effectively occur if farmers are well organised and work together on a successful selection scheme to reach a higher genetic gain while avoiding costs for progeny test and significantly reducing the generation interval.

Incorporation of molecular information as selection criteria is currently used in dairy cattle due to the low reproduction rate and long generation interval. In small ruminants fertility is typically not such a problem resulting in high availability of young males and they have a shorter generation interval. Therefore, use of GS is not yet widely applied in small ruminants such as goats and sheep. The use of GS for genetic improvement and the case for the integration of molecular information into genetic improvement programmes for sheep and goats were pointed out by Dodds et al. (2007). Muioli et al.(1998),Van der Werf et al. (2007) and Notter et al. (2007) suggested the need for more work on goat DNA for economically important traits. Barrera-Saldana et al. (2010) and Gama & Bressan (2011) showed the possibility of incorporating molecular information into breeding programmes and suggested the need for a faster integration of genomic and phenotypic information into comprehensive genetic improvement programmes for dairy goats. This is further supported by the recent publication of the development of next generation sequencing of the goat genome which will enable the production of SNP chips to screen for genetic variants and subsequently the use of genomic assisted genetic improvement (Dong et al. 2012).

Periodic review and economic analysis is an important step in the evaluation of the effectiveness of a breeding programme (Harris et al. 1984). This could lead to changes in the breeding objectives and, although less likely to changes in the breeding scheme. Changing the breeding goal takes time due to the slow turnover of generations. Therefore, it is highly recommended to define the breeding goals and objectives for future market values rather than relying solely on historical data (Harris & Freeman 1993). Simulation methods can mix historical data with expected future conditions to arrive at an objective definition of breeding objectives to make selection decisions. Garrick & Lopez-Villalobos (1998) stated that the simulation model must assume that the breeding programme is not under the

control of the industry, but a result of the collective actions of dairy farmers in concert with economic and genetic aspects of the available genetic material. A difficulty with any simulation model is the definition of the parameter which measures the overall effectiveness of the breeding programme. A further challenge is the way in which the industry bodies, for example artificial insemination companies, continuously review their breeding programmes to evaluate current and future changes at the farm or industry level (Dekkers et al. 1996; Rendel et al. 1996).

CONCLUSIONS

Application of comprehensive genetic improvement programmes in animal industries has been documented by many authors who provide a logical and systematic approach to the development of genetic programmes for dairy goats. Definition of the breeding goal and breeding objective for New Zealand dairy goats should respond to the current and possible future conditions of the dairy goat industry. The breeding objective for a sustainable and profitable dairy goat production industry should contain all traits affecting the breeding goal.

The prediction of lactation curves from test day records have not yet been systematically investigated for New Zealand dairy goats. These predictions are needed to assist with genetic and husbandry improvement. Genetic improvement programmes for dairy animals in New Zealand need to consider the use of progeny testing schemes, which increase selection accuracy and, possibly, genetic gain despite the increase in generation interval. The future incorporation of genomic selection into the dairy goat selection scheme should reduce the generation interval and possibly increase the genetic gain thereby avoiding the cost of progeny testing. However, the efficiency of genomic selection in the New Zealand dairy goat industry requires examination.

CHAPTER 3
DAIRY GOAT PRODUCTION SYSTEMS IN WAIKATO, NEW
ZEALAND

**Published as in Proceedings of the New Zealand Society of Animal
Production: Solis-Ramirez, J., Lopez-Villalobos, N. & Blair, H.T. 2012.
Economic values for New Zealand dairy goats. Proceedings of the New
Zealand Society of Animal Production.71:86-91(re-formatted)**

ABSTRACT

Thirteen dairy goat farmers from the Waikato region of New Zealand were surveyed to describe and quantify the main features of their production systems. Twelve herds were maintained indoors and one herd was under grazing conditions, the latter farm was excluded from further analyses. All farms supplied milk to the Dairy Goat Cooperative (NZ) Ltd which produces milk powder for export. A total of 11 breed groups were identified. Out of the total milking does, Saanen was 88%, Toggenburg x Saanen 8%, Toggenburg 2% and others 2%. The average herd comprised 20% replacement kids, 17% does between 7-12 months 59% does 1 to 10 years and 4% bucks. Culling of milking does was due to low production (35%), poor fertility (14%), leg problems (6%), mastitis (6%) and other reasons (13%), while 27% died between 1-10 years. Daily milk yield per doe and per hectare were 2.8 ± 0.2 and 34.0 ± 3.7 kg; while milk-solids were 0.32 ± 0.02 kg/doe and 4.10 ± 0.43 kg/ha, respectively, over a standardised 270 day lactation. Expenses were mainly feed concentrates (21.5%), dairy wages (20.3%), overheads (14.0%), family labour (14.5%) and other expenses (21.5%). The rates of return on investment were 10.2% and 10.7%, per milking doe and per hectare, respectively.

Keywords: dairy goats, return on investment, production system, milk-solids, survey.

INTRODUCTION

Commercial dairy goat farming began in New Zealand in the late 1970's and early 1980s (Orr 2010; Shepperd & O'Donnell 1979). This production system was considered as an emerging industry in New Zealand in the 1990's decade (Singireddy et al. 1997).

In the last 50 years the annual increase in general New Zealand goat population was 5700 animals, but in the last 10 years a decrease of 9000 animals per year has been reported (FAO 2010a). Factors like improving animal efficiency, reduction of meat and fibre goat populations and lack of competitiveness with dairy cattle and sheep farming have contributed to the decrease in the general goat population in New Zealand. However, in the dairy goat population, there is evidence that the average number of milking does per herd have increased since 1991 (Morris et al. 1997;

Morris et al. 2006; Singireddy et al. 1997). Since the dairy goat was introduced into New Zealand, it has sustained a steadily growing industry, mostly around the Waikato region .

The Waikato region has a well-established dairy goat industry with about 65% of the New Zealand dairy goat population (Orr 2010), and 35% being distributed through the rest of New Zealand. Surveyed dairy goat farmers are organized into the Dairy Goat Cooperative, (NZ) Ltd (DGC) located at Hamilton where milk is made into milk powder and exported to several countries. DGC operates a seasonal production system with goats typically in milk from July-August to April-May each year. However, the structure of the Waikato and New Zealand dairy goat production system has not been described. Therefore, the objective of this study was to collect data by means of a survey to describe the structure of the dairy goat production system. This will then allow the calculation of economic values for traits that can be part of a breeding objective of the dairy goat population in Waikato.

MATERIALS AND METHODS

Location of study site

Thirteen dairy goat farmer members of the Dairy Goat Cooperative, (NZ) Ltd. (DGC) from the Waikato region were surveyed face-to-face and data were recorded to describe and quantify the main features of the goat production system they used. The farms were located in Hamilton, Cambridge, Te Awamutu, Morrsville, Te Aroha, Taupiri, Walton and Matamata. Twelve farms maintained their herds indoors and one herd was maintained outdoors. For the general description of the production systems in the survey, the outdoor farm was removed from the analysis, as were their Saanen x Boer cross kids for meat production.

Format construction and features of survey

The survey format was developed to record the general, physical, economic and management characteristics of the dairy goat farm. Therefore, herd structure, milk yield and milk-solids production, land area and use, farm expenses and overheads, number and age of animals, buildings and equipment available, causes of culling

and deaths, live-weight and breed groups were accounted for. Data for protein, fat and lactose were provided by the DGC through direct communication (C. Prosser, personal communication). The survey was undertaken on the first week of June 2010, when data from the previous lactation season was available.

Data were analysed on a per milking doe and per ha basis for an average of 270 days in milk. The milking period ranged from eight and a half to ten months. The most frequent lactation length was about nine months (270 days in milk). Mean, maximum and minimum, standard deviation and percentage values for different characteristics were also calculated.

Herd structure

Herd structure information requested included: birth to weaning (males and females), weaning to six-seven months old (males and females), 7-12 months old (males and females), 1-2 years, 2-3 years, 3-4 years, 4-5 years, 5-6 years, 6-7 years, 7-8 years, 8-9 years, 9-10 years and 10+ years old does. Bucks used for an average of three seasons were considered also in the herd structure. Milking does were female goats that were milked at least once and provided revenue during the season.

Deaths and culling

The deaths and disposal recorded per age category were those that occurred after removal of surplus kids at birth. The main causes of death and culling in the herd were recorded.

Breed groups

Breed groups were all the purebred and crossbred animals with a known breed pedigree.

Farm revenues

Dairy goat farm revenue (R) was calculated as,

$$R=(MSY \times PMS) + (A_c \times P_a),$$

where, MSY = total kilograms of milk-solids produced, PMS = price per kg of milk-solids, A_c = the number of culled animals and P_a = average price received for the culled animals.

Cost of production

All the expenses influencing the cost of production on the farm in order to calculate the total costs per doe and per ha were recorded (Table 3.1). Farm expenses and overheads were added to get the total farm expenses.

Table 3.1. Main expenses recorded in the dairy goat farm.

General expenses :	Overheads:
Dairy wages	Repairs and maintenance
Animal health	Vehicle expenses
Breeding animals	Administration
Herd testing	
Farm dairy expenses	
Electricity	
Pasture renovation	
Run off	
Imported silage	
Imported hay	
Imported concentrates	
Freight	
Seed cost	
Fertilizer and its spreading	
Imported minerals	
Cropping cost(e.g.contract h. and s. making)	
Weed and pest	
Bedding (shavings)	
Others cost such as dogs, water supply, insurance.	

Capital value

The capital value invested (C) per farm was recorded as the value of land, livestock, milking shed, DGC shares, houses and other buildings and current value of equipment.

Return on investment

Return on investment (ROI) was calculated as suggested by Horngren et al. (1997)

$$\text{ROI} = \text{R} / \text{C}$$

At the request of the Dairy Goat Cooperative Ltd, all expenses, revenue and return on investment were expressed as a percentage of the total for each farm.

RESULTS AND DISCUSSION

General farm characteristics

Out of the total farms considered in this survey 12 maintained their does indoors and one maintained their does outdoors. Indoor production is characterised by harvesting forage and crops and transporting and offering the feed to goats held indoors. Additional supplementation with concentrates may be offered. In contrast, outdoor production is the traditional grazing animal system. Some supplementation with feed concentrates may occur. According to dairy goat farmers considered in the survey, farms have about 66% of the total farm area dedicated to goats with the remaining 34% being dedicated to other activities, such as beef and sheep production, forestry or conservation. All farms had milking sheds, refrigeration for milk storage, tractors, pasture harvesting and other equipment and transport for family and goods to the farm. Milk was collected by the DGC.

Breed groups

Herds consisted of a composite breed pool with 11 breed groups identified (Table 3.2). The basis of the dairy goat production in Waikato utilises purebred Saanen or Saanen by Toggenburg crosses which accounted for 97.5% of milking does. No does from Boer and Nubia were found. Purebred Boers were bucks which were crossed with Saanen does to produce kids for meat production at 5 to 6 weeks with an average carcass weight of 8 kg.

Herd structure

The average dairy goat herd present in the 2009-2010 production year is shown in Table 3.3. The values of 20.2% and 24.5% are an indicator of the replacement rate

in the whole and in the milking does, respectively. The number of breeding does and bucks indicate an average mating ratio of 22 does per buck (1:22). This is lower

Table 3.2. Number and percentage of animals per breed group in the whole dairy goat herd (does, bucks and kids) and in the milking does.

Breed group	Herd		Milking does	
	Total	Percentage	Total	Percentage
Saanen (S)	11170	85.6	6893	88.5
Toggenburg (T)	322	2.4	163	2.1
T XS	1170	9.0	590	7.6
S XT	145	1.1	105	1.4
S XN	161	1.2		
Other ¹	91	0.7	37 ²	0.5 ²
Total	13055	100	7788	100.0

¹, Other includes: Alpine (A), Nubian (N), Boer (B), A x S, N x T and S x B. ², Only Alpine was present.

than some values reported by Mellado et al. (1996) (1:75; 1:50); Lindsay & Skerrit (2003) (1:50) and Bett et al (2007a) (1:50), but similar values to those reported by Bett et al. (2011) (1:25), Mellado et al. (1996) (1:20), Lindsay & Skerrit (2003) (1:15 and 1:20), Dzakuma (2010) (1:20) for some dairy goats systems overseas. Examples of ram:ewe ratios used in sheep under New Zealand and Australian grazing conditions are 1:40 (Howe 1987), 1:50 and 1:100 (Davis et al. 1990) and 1:50, 1:81 and 1:100 (Kilgour 1993). Artificial insemination of does is still not a widespread practice in the New Zealand dairy goat industry, but its use is increasing (Morris et al. 2006; Prosser 2010). The age structure of the herds showed a typical production animal distribution with the biggest number of rearing kids and pregnant does for replacement during first year and the lowest in the last years of productive life of does (Table 3.3). The average number of milking does or mixed animals (does, bucks, and kids) per ha was 12.4 (range = 8.0 to 16.0) and 20.6 (range = 13.7 to 31.7), respectively. The average number of does per herd reported in Northland (Morris et al., 1997; 2006) and in Waikato farms (J. Solis-Ramirez, unpublished data) grew from 180 in 1991 to 648 milking does per herd in 2010 suggesting that the average dairy goat herd size is increasing in New Zealand.

Deaths and culling age

The number of deaths and culling of milking does are presented in Table 3.4. About 40% of culling in the milking does was directly related with production performance, while other health problems and deaths accounted for 41%. The remainder of culling in the herd was due to fertility and lameness problems.

The indoor production system restrains parasites to very low levels due to high control of intake and animals health monitoring. One farm had 9 bucks culled because of parasites, but these animals were run on grass when they were out of the breeding season. Other reasons for culling and deaths supplied by the farmer with unknown specific frequency were pneumonia, high somatic cell count, listeriosis, pregnancy toxemia, intoxications with fungi, blood poison, Johne's disease, kidding problems, ketosis, eczema, injuries and caprine arthritis encephalitis.

Milk and milk-solids production

The mean daily values per doe and per hectare of milk yield, milk-solids, fat, protein, lactose and minerals are presented in Table 3.5.

Milk-solids are fat, protein, lactose and minerals present in the milk; therefore, total milk-solids includes all four components. These values assist in understanding the level of production efficiency compared with other animal production systems. The mean of milk yield and milk-solids per doe and per ha were similar to average production levels for milking does under indoor conditions from other countries (Torres-Vazquez et al., 2009; Donkin & Boyazoglu, 2010), but higher than the previous values reported by Morris et al. (2006) from a New Zealand herd.

Data provided by the DGC showed an average concentration of 0.118 kg milk-solids per day per milking doe per kilogram of milk, and 3.7%, 3.2%, 4.4% and 0.7% for fat, protein, lactose and minerals, respectively. Fat content in goat milk in this study (3.7%) was very similar with other authors (Andonov et al. 2007; Donkin & Boyazoglu 2010; Reynolds 2010; Torres-Vázquez et al. 2009), but the content of protein in this study of 3.2% was slightly higher than other authors in different countries (Andonov et al. 2007; Donkin & Boyazoglu 2010; Torres-Vázquez et al. 2009) and also higher than a previous study in New Zealand (Morris et al. 2006).

The variation in milk yield and milk-solids figures suggests there is a scope for genetic improvement.

Table 3.3. Herd structure per age of the dairy goat farm.

Age category	Total	Mean	Min	Max	Percentage of herd	Percentage of milking does
0-7 mo. kids	2635	220	100	600	20.2	
7-12 mo Replac. Does	2191	183	21	378	16.8	
Milking does (years):						
1-2	1902	159	73	300	14.6	24.5
2-3	1686	141	74	300	12.9	21.7
3-4	1406	117	69	250	10.8	18.0
4-5	1153	96	40	225	8.8	14.8
5-6	640	64	10	108	4.9	8.2
6-7	354	35	3	108	2.7	4.6
7-8	209	23	6	72	1.6	2.7
8-9	161	18	4	71	1.2	2.1
9-10	142	18	1	69	1.1	1.8
10-11	123	21	7	68	0.9	1.6
Bucks	453	38	12	92	3.5	100.0
Total	13055	1197			100.0	

Table 3.4. Culling and deaths of milking does in the dairy goat herd.

Reason	Mean	Min	Max	Percentage
Culling:				
Poor fertility	23.3	1	69	12.3
Mastitis	11.1	1	32	6.2
Leg problems	11.1	1	71	6.2
Low production	62.5	7	157	34.9
Other reasons	33.9	6	80	18.4
Subtotal culling	141.9			77.0
Deaths	42.3	4	191	23.0
Subtotal deaths	42.3	4	191	23.0
Total culling and deaths	184.2			100.0

Table 3.5. Daily milk and milk-solids production, percentage values for cost of production, revenues and return on investment per milking doe and per hectare of dairy goat farms in New Zealand.

Concept	Item	Per milking doe				Per hectare			
		Mean	Min	Max	Stdev	Mean	Min	Max	Stdev
Milk and milk-solids production (kg):	Milk production	2.78	2.10	4.10	0.63	34.00	20.10	61.22	12.44
	Milk-solids	0.33	0.24	0.46	0.08	4.10	2.33	7.35	1.56
	Fat	0.10	0.07	0.14	0.02	1.27	0.70	2.36	0.53
	Protein	0.09	0.06	0.12	0.02	1.07	0.62	1.92	0.40
	Lactose	0.12	0.09	0.17	0.03	1.50	0.86	2.66	0.55
	Minerals	0.02	0.01	0.05	0.01	0.23	0.12	0.53	0.12
Expenses (%) ¹	Family labour	14.8	4.4	34.7		14.2	5.4	32.4	
	Dairy wages	20.1	9.1	38.5		20.4	7.3	43.2	
	Concentrates and minerals	21.1	8.9	45.0		22.1	7.3	63.0	
	Fertiliser and bedding	8.2	1.9	15.5		7.9	1.5	14.0	
	Other farm expenses ²	21.8	6.7	44.6		21.3	6.7	45.8	
	Overheads	14.0	9.1	23.5		14.1	6.5	30.8	
	Total farm expenses	100.0	53.0	138.5		100.0	42.5	160.0	
Revenue (%) ¹	Milk-solids	99.90	72.504	141.60		99.900	57.200	180.300	
	Culled does	0.094	0.003	0.13		0.080	0.005	0.016	
	Culled bucks	0.006	0.002	0.01		0.005	0.003	0.007	
	Total revenue	100.000	72.610	141.74		100.000	57.300	180.300	
	Return on investment	10.2				10.7			

¹, minimum and maximum values for expenses and revenues are expressed as percentage value from the mean. ² cropping, electricity, herd testing, run off, etc.

Farm expenses and overheads

Percentage values for farm expenses and overheads are presented per doe and per ha in Table 3.5.

In general the mean values per milking doe and per hectare were similar. The range was greater on a per hectare than on a per doe basis, except for family labour and fertiliser and bedding. The major expense is labour, the combined values of family labour and dairy wages with 34.8% of the total cost, while concentrates and mineral supplements were 21.6%. Other expenses related to pasture renovation and management were 21.5% and overheads accounted for 14.0%. Family wages were higher on a per doe than on a per hectare basis, whereas expenses for concentrates and minerals were higher on a per hectare than a per doe basis. This indicates that increasing the stocking rate will decrease the cost of production, but cost of concentrates and minerals will increase. These results show the important role of family labour and the small amount spent on supplementary concentrate feedstuffs in the indoor production system, where cropping and transporting the forages to the goats assist in increasing feed production costs. However the advantage of the New Zealand production system is the good climatic conditions for forage production which reduces production cost.

No comparable literature for dairy goat or sheep farming obtained under similar circumstances to this work was found. However, Bett et al. (2011) recently published an estimate of lower production costs for smallholder production systems in Kenya with higher costs for veterinary services, labour and selection. In a comparison with dairy cattle farming costs (DairyNZ 2007, 2009, 2010). The average area in dairy cattle farms is two and a half times greater than the area of dairy goat farms. Dairy goat farms expenses on a per hectare basis were around 50% higher; with twice the usage of supplementary concentrate, similar fertilizer usage, double the labour costs and 1.7 times higher animal health costs than on the average dairy cattle farm.

Farm revenue

Dairy goat farm revenue is dependent on milk-solids production due to the low price for goat meat. Milk-solids revenue was more than 99% of the total revenue, while culled does and culled bucks accounted for less than 1%. Incomes from other sources for the

farmer were not considered in this analysis.

Only 1 out of 13 farms were involved with goat meat production and one farm sold a small number of breeding animals. The sales were not accounted for as the purpose of this survey was to focus only on milk production traits.

Return on investment

Considering the capital value invested per milking doe and per hectare, the Return on Investment (ROI) was 10.2% per doe and 10.7% per hectare (Table 3.5).

In general, these values are lower than the lowest value of 11.3% reported for dairy cattle (DairyNZ 2007, 2009) except for the survey 2008-2009 where the value was negative due to a decrease in livestock and dairy company share value (DairyNZ 2010).

CONCLUSIONS

Dairy goats in the groups of farmers surveyed in the Waikato region in New Zealand were predominantly maintained under indoor conditions with production focussed on powder milk production for export. This survey showed that the size of Waikato dairy goat herds of New Zealand has increased in the last two decades with a high dependence on Saanen breed, with dairy goat farmers obtaining an acceptable return on investment. The information collected in this survey will be used to prepare a farm model which will enable the calculation of economic values for traits contributing to farm revenue and costs. The economic values to be calculated will be used in the construction of a selection index.

CHAPTER 4
MODELLING OF LACTATION CURVES FOR NEW ZEALAND DAIRY
GOATS USING RANDOM REGRESSION MODELS: SELECTION OF
THE BEST MATHEMATICAL MODEL

ABSTRACT

A total of 154,984 test-day records from 18,715 milking does contributing to 43,311 lactations in 35 herds from the Waikato region of New Zealand were analysed with random regression models (RRM) using restricted maximum likelihood procedures to evaluate the performance of four mathematical functions to predict lactation yields of milk (MY), fat (FY) and protein (PY) at actual lactation lengths. The four models studied were Legendre polynomials (LG), Wilmink (WK), Ali and Schaeffer (AS) and Wood (WD) models. Random regression model parameters for each animal-lactation of individual milking does were estimated for the three traits and four mathematical functions. The individual model parameters by trait and model were adjusted for herd, breed group, year and lactation number. All parameter values were significantly different from zero ($p < 0.05$), except α_3 and α_2 for FY and PY in the Legendre model, respectively. All correlations were highly significant ($p < 0.01$), except the correlation between α_1 and α_2 in the Legendre model. More typical curves were for milk yield followed by protein and fat yield, and *vice versa* for atypical curves. There were not any AIC significant differences between the LG and WK models. The WK model was selected as the best model based on AIC differences and overall performance on the remaining three fit statistics. Random regression methodology using the WK model can be implemented to report total lactation yields of milk, fat and protein to farmers using herd-testing in New Zealand indoor dairy goats.

Keywords: Lactation curves, mathematical functions, random regression models, Wilmink model, dairy goats.

INTRODUCTION

Breeding objectives of breeding programmes for the genetic improvement of dairy animals include primarily lactation yields of milk, fat and protein and other traits related to fertility, health and survival. Milk production follows a curvilinear shape and can be modelled using different mathematical models, but not all of them will be fitting with the same accuracy.

Important features of a typical lactation curve in dairy animals are initial production, ascending phase, maximum production point and persistence under a standard dairy farm production system (Wood 1967). The number of mammary epithelial cells and

their secretory activity determine the shape of the lactation curve. Depending on the species, increases in the number or activity of mammary secretory cells account for increased milk yield to peak lactation. Conversely, declining mammary cell number or secretory activity accounts for declining milk yield after the peak. Management and diseases can potentially impact the proliferation or loss of cells during lactation. Knowledge about mammary cells that are capable of cell proliferation, and of the pathways that regulate proliferation cell death may provide means to alter persistency of lactation (Capuco et al. 2003; Dijkstra et al. 1997). The shape of the lactation curve in dairy animals is affected by breed, number of lactation and season, and is useful to assist with the evaluation of the biological and economic efficiency of breeds, generations, groups of animals or individual production. Knowledge of the shape of the lactation curve helps farmers and breeders to make management decisions regarding feeding, mating and culling. Predicted curves also assist with estimating total lactation yield from incomplete records, and forecasting herd performance on a time or individual animal basis (Sauvant 1988).

Following the publication of Wood's incomplete gamma function (Wood 1967) several investigations led to the application of several models to describe the lactation curve of dairy animals under different environments and for different dairy cattle breed groups (Ali & Schaeffer 1987; Grossman & Koops 1988; Macciotta et al. 2005; Wilmink 1987a). The models developed were also useful for the genetic analysis of test-day records to account for the effect of lactation stage (Ptak et al. 1993) and to model the covariance between test-day records in a random regression analysis (Jamrozik & Schaeffer 2010).

Random regression models (RRM) allow the estimation of parameters of the lactation curve for each milking doe. This allows the detection of differences in regression coefficients between animals and within animals for the traits over a period of time (Kirkpatrick et al. 1990; Kirkpatrick et al. 1994). Individual regression coefficients make it possible to adjust the parameters for sources of variation affecting the parameter values and to calculate milk, fat and protein curves based on one or more test-day records (TDR) per animal (Schaeffer 2004). Animals with just one record were originally left out of analysis because it was not possible to calculate a lactation curve for those animals. However, using RRM such records can be included in a general random regression analysis and individual lactation curves estimated (Schaeffer 2004).

Early mathematical models developed to describe a lactation curve for milk production in dairy cattle (Ali & Schaeffer 1987; Khan 2009; Macciotta et al. 2005; Wilmink 1987b; Wood 1967) have been applied to modelling of lactation curves in dairy goats (Gipson & Grossman 1989a; González-Peña et al. 2012; Macciotta et al. 2008).

The Wood model (WD) has been reported to describe adequately the lactation curve of daily milk yields of various dairy goat breeds (Fernández et al. 2002; Montaldo et al. 1997; Ruvuna et al. 1995), but other studies reported that the Ali & Schaeffer model (AS) and Legendre polynomials (LG) resulted in a better fit than the WD model (González-Peña et al. 2012). These results suggest an inconsistency in the way in which the mathematical models fit to different conditions. Therefore, further studies are needed to determine the best mathematical model to describe lactation curves for different breed groups or farm conditions, under New Zealand conditions.

Selection of a mathematical model is based on the best fit of the predicted values to the actual values (Bibby & Toutenburg 1978; Khan 2009; Lin 2000; Val-Arreola et al. 2004). Many fit statistics are accepted to evaluate the fitness of a model to data. However, fit statistics differ in their level of complexity and therefore in the structure of their calculation (Bibby & Toutenburg 1978; Val-Arreola et al. 2004). Currently, there is no agreement to use only one fit statistic and therefore different fit statistics are used across research work to choose the best mathematical function for a particular condition. Some examples of fit statistics used to measure fitness between actual and predicted values of a model that were selected for evaluation in this study were the determination coefficient (r^2), the concordance correlation coefficient (CCC) (Crawford et al. 2007; Lin 1989), the Akaike information criteria (AIC) (Akaike 1974; Burnham & Anderson 2004) and the relative prediction error (RPE) (Fuentes-Pila et al. 1996; Visser et al. 2012). The objective of the present study was to evaluate the LG, WK, AS and WD mathematical functions to describe the lactation curves and the r^2 , CCC, AIC and RPE fit statistics using RRM, and to select the best model to predict the lactation trait curves for New Zealand dairy goats.

MATERIALS AND METHODS

Data

A total of 154,984 test-day records (TDR) contributing to 43,311 lactations from 18,715 milking does distributed in 35 dairy goat farms supplying milk to the New Zealand Dairy Goat Cooperative, Ltd of New Zealand (DGC) from the region of Waikato, New Zealand (Solis-Ramirez et al. 2011) were studied. The TDR are electronically stored in a database managed by Livestock Improvement Corporation, Hamilton, New Zealand.

The general features of the farming systems were described by Solis-Ramirez et al. (2011). The average herd structure consisted of 18.6% 0-1 year olds, 14.5% 1-2 year olds, 12.9% 2-3 year olds, 10.8% 3-4 year olds, 8.8% 4-5 year olds, 4.9% 5-6 year olds, 2.7% 6-7 year olds, 1.6% 7-8 year olds, 1.2% 8-9 year olds, 1.1 % 9-10 year olds and 0.9% 10+ year olds. The breed groups were 97.5% Saanen or Saanen by Toggenburg crosses and the remaining 2.5% were mainly British Alpine, Nubian and Saanen by British Alpine and Saanen by Nubian crosses. Milking goats kid once a year and they are milked twice a day for a range of days in milk from 13 to 305 days. The monthly distribution of the TDR for the lactation period adjusted to 270 days in milk is presented in Table 4.1. A highly seasonal kidding period occurred between June and October.

Table 4.1. Distribution of test day records along the lactation period adjusted to 270 days.

Trait	Day in lactation								
	1-30	31-60	61-90	91-120	121-150	151-180	181-210	221-240	251-270
Milk yield	8433	26562	16772	23472	17973	20386	14975	16159	10936
Fat yield	8347	26440	16689	23369	17880	20256	14791	15915	10640
Protein yield	8347	26440	16689	23369	17880	20256	14791	15915	10640
Total	25127	79442	50150	70210	53733	60898	44557	47989	32216

Modelling the lactation curve

Random regression model (RRM)

Individual TDR for milk, fat and protein yield were analysed using RRM to calculate the polynomial regression coefficients for each milking doe for four mathematical models using ASREML (Gilmour et al. 2009). Estimation of individual random

regression coefficients is represented in Figure 4.1 and were obtained using the following steps (Schaeffer 2004):

- 1) Estimation of model parameters for the lactation curve of the population (fixed regression coefficients);
- 2) Estimation of covariances between TDR according to a mathematical model;
- 3) Estimation of the individual mathematical model deviations from the fixed population model lactation curve;
- 4) Estimation of the individual random regression model parameters adding fixed model parameters and individual random deviations,
- 5) Estimation of individual lactation curves using parameters of step 4.

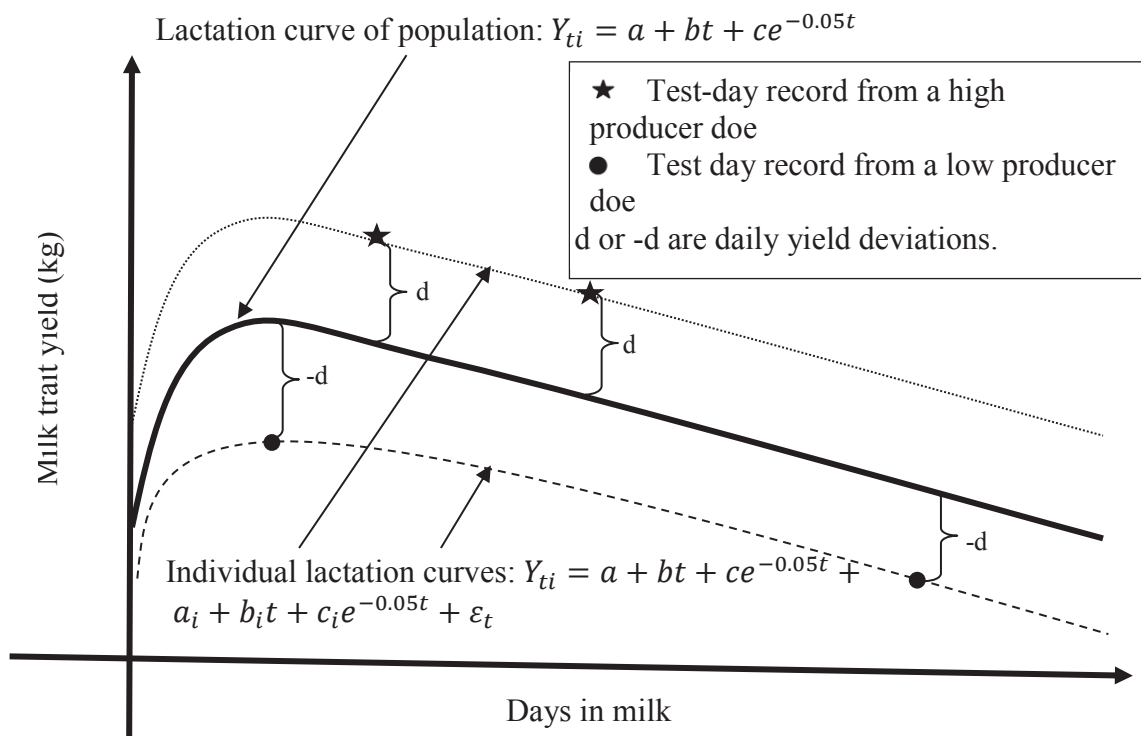

Figure 4.1. Illustration with Wilink model of use of random regression models to estimate individual lactation trait curves in milking does. In individual lactation curves a_i, b_i and c_i are random regression deviations of the model parameters from the population lactation curve.

Using RRM it is possible to use one or more TDR to predict the lactation curve for each individual lactation curve with high accuracy making more efficient use of available TDR and increasing the probability of better management and herd decisions. The structure of RRM was describe by Schaeffer (2004).

Mathematical models

The mathematical functions applied were:

Legendre polynomials model (LG). Legendre polynomials are functions of n degree and domain $n+1$ resulting in a set of equations described by Kirkpatrick (1990), Macciotta et al. (2005) and Silvestre et al. (2006).

A LG model of order 3 (LG3) was fitted to the test-day records. In an initial analysis comparing LG3 with a Legendre model of order 4 (LG4) both had a similar fit to the base data, but LG3 was chosen for further analysis because it had less parameters to estimate. LG3 (in the following text and chapters to be called Legendre or LG only) comprised of four polynomial coefficients (β 's are fixed regression coefficients for the population; α 's are random regression coefficients as deviation from the fixed population curve for individual animals) and four time functions (p 's). In the model, y_{ti} is the milk, fat or protein yield on day t of lactation for each combination of animal-lactation i . The equation is:

$$y_{ti} = (\beta_0 p_0 + \beta_1 p_1 + \beta_2 p_2 + \beta_3 p_3) + (\alpha_{0i} p_{0i} + \alpha_{1i} p_{1i} + \alpha_{2i} p_{2i} + \alpha_{3i} p_{3i}) + \varepsilon_{ti}$$

where:

ε_{ti} is the random error associated with each observation of day t and animal-lactation i ; and functions of p_j of Legendre polynomials were calculated for the population and for individuals (Brotherstone et al. 2000; Kirkpatrick et al. 1990; Spiegel 1971) as:

Parameter	Value
X	$2((t-t_{min})/(t_{max}-t_{min})) - 1$
$p_0(x)$	1
$p_1(x)$	X
$p_2(x)$	$1/2(3x^2-1)$
$p_3(x)$	$1/2(5x^3-3x)$

Ali and Schaeffer model (AS). The model comprised five polynomial coefficients (a , b , c , d and f fixed regression coefficients for the population a_i, b_i, c_i, d_i and f_i are random regression coefficients deviations for each combination animal-lactation i as

deviations from the fixed population curve). The a 's parameters are associated with initial yield, d 's and g 's are parameters describing the upward slope of the curve in early lactation, b 's and c 's are associated with the downward slope after peak lactation (Ali & Schaeffer, 1987), t is days in milk. The number 270 refers to the days adjusted lactation length. The equation is:

$$y_{ti} = (a + b(w) + c(w)^2 + d(z) + g(z)^2) + (a_i + b_i(w) + c_i(w)^2 + d_i(z) + g_i(z)^2) + \varepsilon_{ti}$$

where:

$$w = t/270; \text{ and}$$

$$z = \log(270/t).$$

Wilmink model (WK). This is a combined exponential and linear model (Wilmink 1987a). The equation is:

$$Y_{ti} = a + bt + ce^{-0.05t} + a_i + b_it + c_ie^{-0.05t} + \varepsilon_t$$

The parameters a , b and c are fixed regression population coefficients and a_i , b_i and c_i are random regression coefficients as deviations from the fixed population curve for the animal-lactation i . The a 's, b 's and c 's parameters are associated with the initial level of production, the persistency of production and with the increase in production, respectively, while e refers to the base of the natural logarithm.

Wood model (WD). One of the more frequently used models to describe a lactation curve is the gamma function (Wood 1967). The parameters a , b and c are fixed regression population coefficients and a_i , b_i and c_i are random regression coefficients as deviations from the fixed population curve. In the Wood model, the a 's parameter is a scaling factor to represent yield at the beginning of lactation, and b 's and c 's parameters are factors associated with the inclining and declining slopes of the lactation trait yield curve, respectively and e is base of the natural logarithm. The equation is:

$$Y_{ti} = (at^b e^{-ct}) + (a_it^{b_i} e^{-c_it}) + \varepsilon_t$$

which, when fitted in the logarithmic form, can be expressed as:

$$\log Y_{ti} = (\log(a) + b \log(t) - ct) + (\log(a_i) + b_i \log(t) - c_it) + \varepsilon_t$$

Milk, fat and protein yield curves were estimated using the model parameters of each mathematical model for each combination of milking doe and parity.

For all models, ε_t were the random errors associated with each observation at time t . These are assumed independent and with a normal distribution and a zero mean. An unstructured co-variance matrix was assumed in the ASReml analysis (Gilmour et al. 2009). The large data size in this study allows the use of an unstructured covariance for the random effects. Unstructured covariance is the most “liberal” of all covariance structures allowing every term to be different, not imposing any constraints on the values and then allowing each variance and covariance to be estimated uniquely from the data.

The covariance functions and random regression models are used for traits that are measured on trajectories (Brotherstone et al. 2000; Kirkpatrick et al. 1990; Spiegel 1971), e.g. time and lactation yield curves. The covariance function gives the variance and covariance of TDR measured at different points on the trajectory on a lactation curve. Estimations of fixed regression coefficients and individual regression coefficient deviations have been already described in the previous random regression section. The matrix notation for a co-variance function has already been described by Schaeffer (2004), and is represented as:

$$\mathbf{y}_t = \mathbf{X}\mathbf{b} + \mathbf{Z}\mathbf{u}_t + \mathbf{e}_t$$

where;

\mathbf{y}_t = a response variable observation at time t , this is the milk trait yield at day t of lactation;

\mathbf{X} = the incidence matrix of time components of mathematical models;

\mathbf{b} = the vector of fixed regression coefficient effects for the dairy goat population and represent the first part of the mathematical models expressions presented in the mathematical model section;

\mathbf{Z} = the incidence matrix of time components of mathematical models for each of the random effects;

\mathbf{u}_t = the random effect of the animal-lactation combination (regression coefficient deviations for each combination animal-lactation as deviations from the fixed population curve), and represents the second part of the mathematical models' expressions presented in the mathematical model section;

\mathbf{e}_t = the random error associated with each observation of day t and animal-lactation combination of a mathematical model.

It is assumed that $\text{var}(\mathbf{u}_t) = \boldsymbol{\phi}\mathbf{K}\boldsymbol{\phi}'$, where: $\boldsymbol{\phi}$ = is a matrix of txk order for time functions, \mathbf{K} = matrix of co-variance function coefficients and $\boldsymbol{\phi}'$ = transpose of matrix $\boldsymbol{\phi}$; also, it is assumed that $\text{var}(\mathbf{e}) = \mathbf{I}\sigma_e^2$, where \mathbf{I} = identity matrix and σ_e^2 = variance of the error term.

Identification of typical and atypical lactation curves

After a preliminary view and screening for zero, positive and negative values for each model parameter estimated, value parameters were ranked as positive or negative and all possible combinations between them within model to detect different types of possible typical and atypical lactation curves for MY, FY and PY using the four mathematical models. Each of the different types of the individual lactation curves found were simulated for each mathematical model to observe if they were typical or atypical. The total number of detected types of lactation curves in the total TDR or lactations base data was accounted for.

Fit statistics of the mathematical models

Fit statistics are important to select the best mathematical model to describe the lactation trait curve from current TDR of a population, herd or individual (Bibby & Toutenburg 1978; Macciotta et al. 2004). Four fit statistics for each of the mathematical models were calculated using SAS Version 9.3 (SAS, 2012).

- 1) **Relative prediction error (RPE)**. An assessment of the error of predicted values relative to the actual values of milk traits was made by calculation of the Root Mean Square Prediction Error and expressed as a percentage relative to the mean of the actual values (RPE). This is the average of square deviations between predicted values and actual values relative to the average of the actual values and expressed as percentage, the equation was:

$$\text{RPE} = \left\{ \left[\sqrt{\frac{\sum_{i=1}^n (A_i - P_i)^2}{n}} \right] / \bar{A} \right\} 100$$

where:

A_i = actual trait yield values;

P_i = predicted trait yield values;

\bar{A} = mean of actual trait values, and

n = number of observations.

- 2) **Coefficient of determination (r^2)**. It is interpreted as the proportion of the variance in the dependent variable that is explained by the independent variable. This fit statistic is estimated as the square of the correlation coefficient between predicted and actual values of a trait.

$$r^2 = [\sigma_{AP} / \sigma_A \sigma_P]^2,$$

where:

σ_{AP} = covariance between actual (A) and predicted (P) values;

σ_A and σ_P = standard deviation of actual and predicted values.

- 3) **Concordance correlation coefficient (CCC)**. The CCC considers bias from the concordance line and how far each observation deviates from the fitted line (precision) (Crawford et al. 2007; Lin 1989). This is a measure of agreement between actual and predicted values. It was calculated as:

$$\text{CCC} = \frac{2\sigma_{AP}}{(\sigma_A^2 + \sigma_P^2) + (\bar{A} - \bar{P})^2}$$

where:

σ_A^2 = variance for actual trait yield values,

σ_P^2 = variance of predicted trait yield values.

\bar{P} = mean of predicted trait values

σ_{AP} , A and P have been defined previously.

Simple regression coefficients of predicted (P) on actual (A) yield values for MY, FY and PY were estimated for each model. The regression coefficients β_0 and β_1 shows the intercept (or initial production) and the slope of the regression line (increase in daily yield of the trait).

- 4) **Akaike information criteria (AIC)**. The AIC takes into account both the statistical goodness of fit and the number of parameters that have to be estimated to achieve

this particular degree of fit. It imposes a penalty for increasing the number of parameters in the model. Akaike's equation (Akaike 1974) is defined as:

$$AIC = -2 \log(L) + 2\rho$$

where:

log = natural logarithm;

ρ = number of parameters, and

L = maximum likelihood estimation.

The AIC was estimated using the last log(L) of the ASReml output when parameters converged. For AIC, differences between AIC values of models within each trait ($DIFF_i$) were calculated as

$$DIFF_i = AIC_i - AIC_{min}$$

where:

$DIFF_i$ = difference in value of AIC for model i (from model with minimum AIC);

AIC_i = AIC from model i ;

AIC_{min} = AIC from model with minimum AIC;

The odd ratio for a given model i (OR_i) was estimated as the ratio between relative probability that model i minimises the expected estimated information loss for the i model (Ω_i) relative to the model with the lowest Ω value (Ω_{min}). Ω was estimated as:

$$\Omega_i = e^{(DIFF_i)/2}$$

while OR_i was estimated as:

$$OR_i = \frac{\Omega_i}{\Omega_{min}} = \frac{e^{(DIFF_i)/2}}{e^{(DIFF_{min})/2}}$$

where:

e = base of the natural logarithm base e and other terms were previously defined.

Akaike weights for model i (AW_i) were estimated as weight of evidence in favour of a model and is the probability that model i is the best model. The calculation was as,

$$AW_i = \frac{e^{(-\frac{DIFF_i}{2})}}{\sum_{r=1}^4 e^{(-\frac{DIFF_r}{2})}}$$

where:

r = refers to model r from the total number of models ($r=1$ (LG), 2 (WK), 3 (AS) and 4 (WD));

e , AW_i and $DIFF_i$ were defined previously.

Fit statistics were estimated for the whole population using the equations previously mentioned.

Selection of the best mathematical model to represent the data should be based on the highest values for r^2 or CCC but for the lowest values for AIC or RPE. Furthermore, the best model can be selected based on the lowest AIC (highest OR or higher AW) values (Burnham & Anderson 2004). Equal or lower differences than two in AIC values between models were considered not significantly different between models (Burnham & Anderson 2004).

The selection of the best model was based on AIC values and the significance test between models according to Burnham & Anderson (2004) for New Zealand indoor dairy goats.

Statistical analysis

A linear model was used to estimate least square means for each parameter of the lactation curve and lactation yield of each of the mathematical models using PROC MIXED of SAS Version 9.3 (SAS, 2012). The statistical model was:

$$y_{ijklm} = \mu + B_i + L_j + A_k + H_l + \varepsilon_{ijklm}$$

where:

y_{ijklm} = the estimated m random regression model parameter (or lactation yield) for a milking doe of breed group i ($i=1,\dots,10$), lactation number j ($j=1,\dots,5$), kidding in year k ($k=1,\dots,20$) and herd l ($l=1,\dots,35$);

μ = population mean;

B_i = fixed effect of the i -breed group ($i=1, 2,\dots,10$);

L_j = fixed effect of the j -lactation number ($j=1, 2,\dots, 5$);

A_k = fixed effect of the k -year ($k=1989, \dots, 2009$);
 H_l = fixed effect of the l -herd ($l=1, \dots, 35$), and
 ε_{ijkl} = residual error associated to the y_{ijkl} observation.

Random errors (ε_{ijkl}) were assumed to be independent and normally distributed with $\mu = 0$ and variance = σ_e^2 .

RESULTS

Population lactation curves

Least squares means for each model parameter and the correlations between model parameters of the four mathematical functions are presented in Table 4.2 and Appendix 4.1, respectively. All parameter values were significantly different from zero ($p < 0.05$), except α_3 and α_2 for FY and PY in the Legendre model, respectively. All correlations were highly significant ($p < 0.01$), except the correlation between α_1 and α_2 in the Legendre model.

The lactation trait curves for the dairy goat population for the four models are shown in Figure 4.2. Similar curves were observed across the models with differences at the start and end of the lactation. The AS model showed the strongest decline in PY in the first two weeks of lactation, which did not occur in the MY and FY curves.

Comparison between the models at the beginning of lactation (intercept) showed a higher value for LG and WD models for MY, WK and LG for FY and AS and WD for the PY curve; while at the end of lactation variation in performance was similar between LG, WD and WK for MY, among WK, AS and WD for FY and among WD and AS for FY.

The AS model showed the fastest increase in MY, FY and PY in the first 30 days of lactation, but the intercept for the LG model was higher for MY and FY. The decay trends of the LG, WK and WD models showed similar patterns; however, the LG model had the lowest decay trend followed by WK, WD and AS for MY. The AS model predicted a faster increase of yield in the first twenty days of lactation, but declined faster in last forty days of lactation than the other three previous models (Figure 4.2).

Individual lactation curves

Figure 4.3 shows the individual MY, FY and PY curves from two randomly chosen milking does with the same number of TDR representing high or low yielding milking does. The high yielding doe and the low yielding doe showed very similar curves to those for the whole population, except for the LG model at the end of lactation. While the AS model curve showed the strongest decline in FY and PY early in lactation, this trend was followed by the LG, WK and WD models. The milk curve for the low yielding doe using the LG model had a higher intercept than the high yielding doe using the WD model. Lactation curves for each lactation showed a variable number of typical and atypical shape curves for milk, fat and protein yields. This shows the distribution of typical and atypical shape curves for milk, fat and protein yield.

Table 4.2. Least square means (standard errors)¹ of the parameters of the lactation curve obtained from four mathematical models for milk traits of New Zealand dairy goats.

Model	Parameter ²	Milk yield (MY)	Fat yield (FY)	Protein yield (PY)
Legendre (LG)				
	α_0	4.08(0.029)	0.14(0.001)	0.12(0.008)
	α_1	-0.75(0.002)	-3.29(0.055)	-2.05(0.043)
	α_2	-0.15(0.002)	0.61(0.051)	-0.01(0.040)
	α_3	0.09(0.012)	0.03(0.044)	0.26(0.034)
Wilmink (WK)				
	a	4.15(0.034)	0.14(0.001)	0.12(0.009)
	b	-2.13(0.026)	-0.03(4x10 ⁻⁵)	-2.39(0.064)
	c	-0.01(1x10 ⁻⁴)	1.087(0.068)	-0.02(3x10 ⁻⁵)
Ali & Schaeffer (AS)				
	a	4.13(0.009)	0.09(0.001)	0.17(0.001)
	b	-0.81(0.008)	-0.01(1x10 ⁻⁵)	-0.12(1x10 ⁻⁵)
	c	-0.19(0.001)	-2x10 ⁻³ (1x10 ⁻⁵)	7x10 ⁻⁴ (1x10 ⁻⁵)
	d	-2.43(0.001)	0.25(1x10 ⁻⁵)	-0.40(1x10 ⁻⁵)
	e	-0.19(0.001)	-0.02(0.001)	0.07(0.001)
Wood (WD)				
	a	0.21(0.014)	-0.23(0.013)	-0.03(0.012)
	b	0.33(0.005)	-0.05(3x10 ⁻⁵)	0.15(0.003)
	c	-0.01(1x10 ⁻⁵)	-3.5x10 ⁻³ (3x10 ⁻⁵)	-4.5x10 ⁻³ (9x10 ⁻⁵)

¹All means were significantly different from zero (p<0.05). Except values α_3 and α_2 for fat and protein yield respectively in the LG model. ²Parameter refers to the model parameters of each of the mathematical models affecting the stages of the lactation trait curve.

The distribution of typical and atypical lactation curves for the models is showed in Table 4.3. The highest number of typical lactation curves were observed for all mathematical models for MY. The lowest number with typical shapes was using the Legendre model, while the WK and AS models showed the highest number. For FY the LG model had the highest number of atypical curves while the WD model had the highest for typical curves with the WK and AS models performing intermediate. For PY the WD model had the highest number of typical curves, while the AS model had the highest number of atypical curves with the LG and WK models performing intermediate. Details of the number and type of lactation curves per mathematical model and trait are presented in Appendix 4.3.

Fit statistics

Measures of fit by the four different mathematical functions to describe the lactation curves of daily yields are presented in Table 4.4 and Appendix 4.2.

Table 4.3. Number of typical and atypical lactation curves for milk (MY), fat (FY) and protein (PY) yield using four mathematical models in New Zealand dairy goats

Trait	Type	Model	Legendre	Wilmink	Ali & Schaeffer	Wood
Milk yield	Typical	TDR ¹	82050	152148	151508	124240
		NL ²	22929	42518	42340	34719
	Atypical	TDR	72934	2836	3476	30744
		NL	20382	793	971	8592
	Total	TDR	154984	154984	154984	154984
		NL	43311	43311	43311	43311
Fat yield	Typical	TDR	2573	61655	133250	154182
		NL	715	17126	37014	42828
	Atypical	TDR	151407	92329	21734	0
		NL	42058	25647	6037	0
	Total	TDR	153980	153984	154984	154182
		NL	42772	42773	43051	42828
Protein yield	Typical	TDR	88320	133128	1240	151435
		NL	24533	36807	344	42065
	Atypical	TDR	64659	20354	153744	2453
		NL	17961	5627	42707	681
	Total	TDR	152979	153482	154984	153888
		NL	42494	42434	43051	42747

¹Number of test-day records. ²Number of lactations.

Analysis of the r^2 fit values showed that for MY, higher values were estimated for the LG model followed by the WK and AS models then by the WD model. Values for FY

were similar between the WK and LG models followed by the AS and WD models. For PY, highest value was for WK followed by LG, AS and WD models. The lowest value of r^2 was for FY curve using the WD model.

Values of CCC were similar between the LG and WK models for MY and FY followed by the WD and AS models. For PY, WK and AS models had the highest and similar values followed by the LG and WD models. The lowest CCC value was for MY using the AS model.

The RPE estimates ranged from 3.20% to 3.89% for MY, from 3.28 to 4.15 for FY and from 3.41 to 4.10 for PY. The lowest RPE was for the LG model for MY and the WK model had the lowest values for FY and PY (Table 4.4).

Table 4.4. Measures of statistical fitness for four mathematical models to describe the lactation curve of daily yields of milk, fat and protein in New Zealand dairy goats.

Model	Number of parameters	Fit statistic ¹	Milk yield (MY)	Fat yield (FY)	Protein yield (PY)
Legendre (LG)	4	r^2	0.92	0.91	0.89
		CCC	0.92	0.92	0.91
		RPE	3.20	3.30	3.41
		AIC	-11957.6	-10676.2	-10428.0
Wilmink (WK)	3	r^2	0.91	0.91	0.91
		CCC	0.92	0.92	0.92
		RPE	3.25	3.28	3.30
		AIC	-11956.2	-10676.0	-10428.4
Ali & Schaeffer (AS)	5	r^2	0.90	0.85	0.85
		CCC	0.84	0.92	0.92
		RPE	3.71	3.89	4.10
		AIC	-11954.6	-10672.7	-10424.3
Wood (WD)	3	r^2	0.83	0.81	0.83
		CCC	0.90	0.89	0.90
		RPE	3.89	4.15	3.93
		AIC	-11954.2	-10674.0	-10424.0

¹Fit statistics are: r^2 =coefficient of determination, CCC=concordance correlation coefficient, RPE=relative prediction error and AIC=Akaike information criteria.

AIC values were lower for the LG model for MY and FY, but for the WK model for PY. The highest AIC values were for MY and PY using the WD model, while for FY they were for the AS model (Table 4.4). The difference between AIC values for all traits

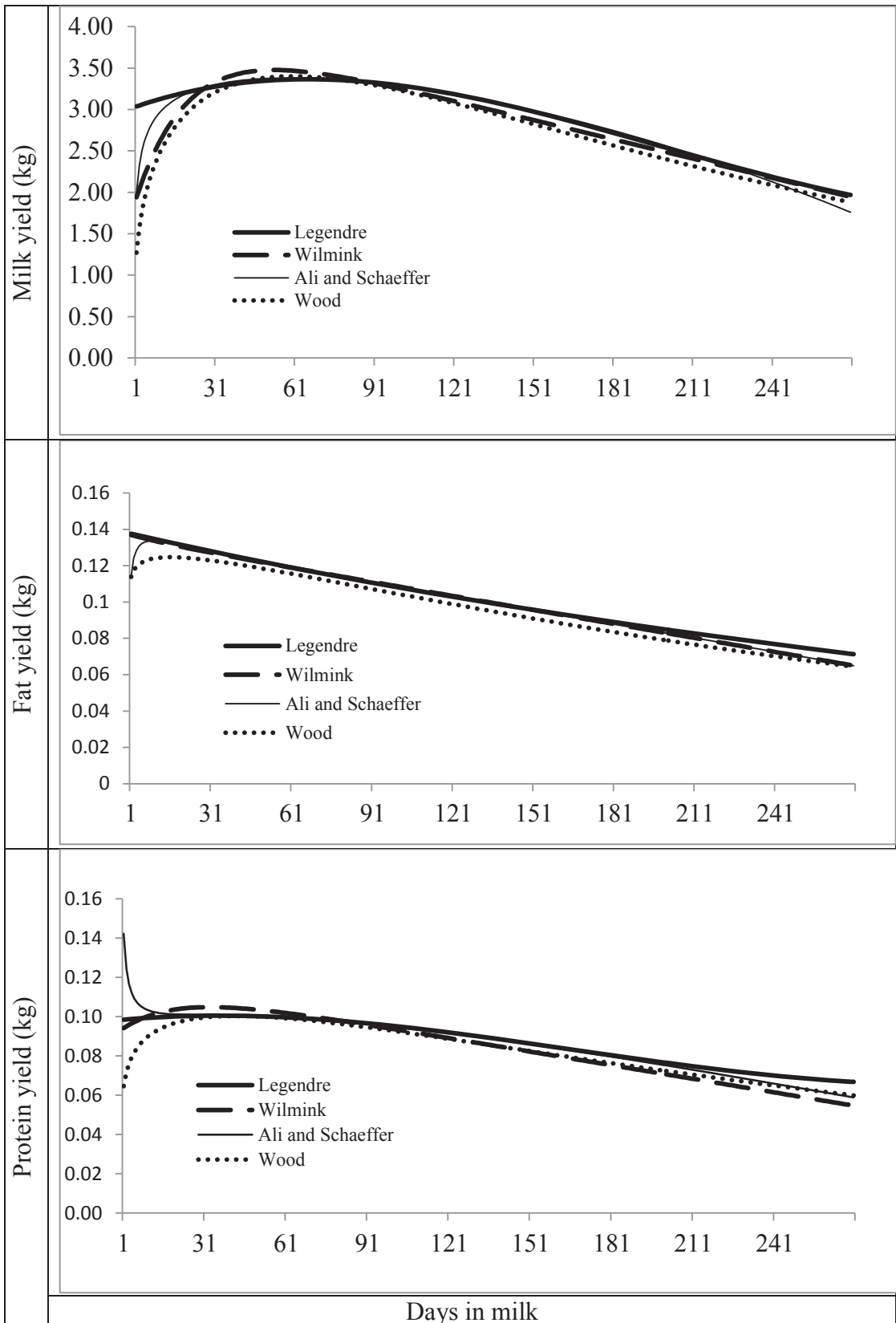

Figure 4.2. Lactation curves for milk (MY), fat (FY) and protein yield (PY) curves (kg) for New Zealand dairy goats using four mathematical models.

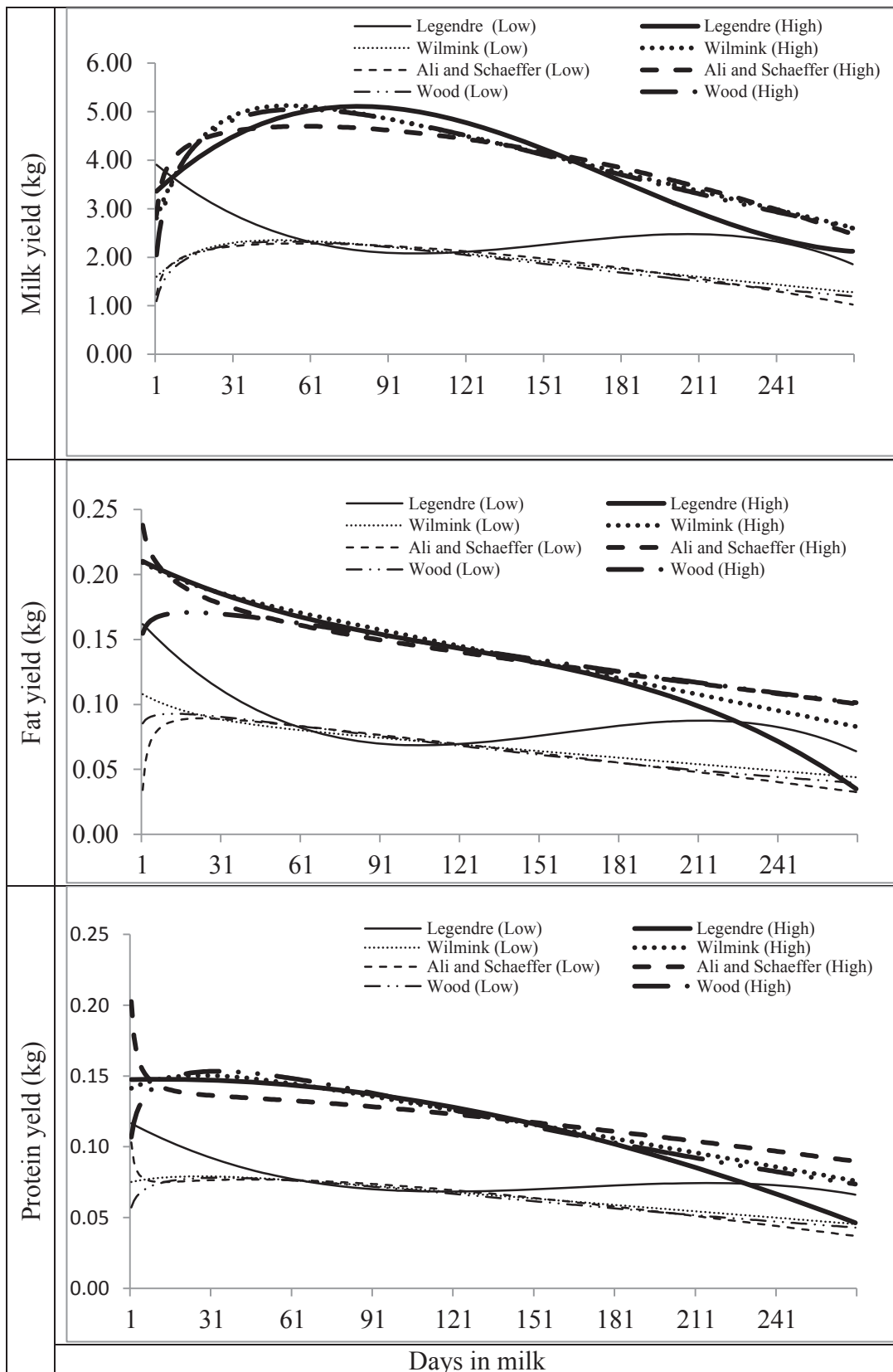

Figure 4.3. Individual milk (MY), fat (FY) and protein yield (PY) curves (kg) for high and low yielding dairy goats producers using four mathematical models.

were smaller than two between the LG and WK models, greater than two between the LG and AS models and between the LG and WD models, but also differences were greater than two between the WK and AS models and between the WK and WD models for FY and PY, respectively, but not for MY. Differences in AIC between the AS and WD models were not important. Regression coefficients of the regression line of actual on predicted values (β_0 and β_1), differences between AIC values (DIFF), the odd ratio for models (OR) and Akaike weights (AW) are presented in Appendix 4.2 of this Chapter.

DISCUSSION

Population lactation curves

Population and individual lactation curves shown in Figure 4.2 and Figure 4.3 suggest that population lactation curves are steadier than individual lactation curves, however the LG and AS models showed larger differences between population and individual curves than the WK and WD models. This could be explained by the way that individual curves are a random sample from the population and they do not necessarily reflect the population trend, since the population lactation curve will be affected by the frequency of the shape or type of lactation curves in each lactation. Furthermore, the number of TDR or lactations affect the lactation curve of each model and the time when they were recorded since fewer TDR were recorded at the start and end of lactation. Population milk yield curves for all models showed a typical shape curve with an ascending phase to a peak of yield followed by a steady decline (Macciotta et al. 2005; Wood 1967).

However, for fat and protein yield, both typical and atypical lactation curves were observed for the LG, WK and AS models. An atypical shape was mainly observed before the first, and over the last, month of lactation. This period coincided with the lowest number of TDR in the population (Table 4.1) and agreed with previous reported findings (Congleton & Everett 1980; González-Peña et al. 2012).

Correlations between the parameters for the four mathematical functions were mostly low and moderate, but highest correlations were observed in FY for the WD model, in MY and PY for the WK model (Appendix 4.1). The values showed the direction of the association of the model parameters, e.g. a value of -0.41 between α_0 and α_1 for the LG

model showed the moderate negative association between the intercept or initial production and the decay of the lactation after the peak of milk yield.

Individual lactation curves

The power of RRM to model lactation curves using one or more TDRs per lactation for each milking doe is demonstrated by the individual lactation curves in Figure 4.2 (Schaeffer 2004). The use of mathematical models allows the detection of typical and atypical lactation curves due to differences in the abilities of the models to describe the shape of the lactation curves (Landete-Castillejos & Gallego 2000). Typical curves show an intercept, an increase of production, a peak of yield and a decrease of yield. Atypical lactation curve shows no peak yield in a lactation curve. Typical and atypical lactation curves have been observed in different goat breeds (Castañeda-Bustos et al. 2010; Fernández et al. 2002; Montaldo et al. 1997). Congleton & Everett (1980) and Silvestre et al. (2006) suggested that no peak in a lactation curve could be due to the absence of records in the first days of lactation. Congleton & Everett (1980) explained that negative values of parameter b in the Wood model appeared as a consequence of the TDR being after the first month of lactation. Silvestre et al. (2006) also indicated that model performance of WK, WD and AS models was influenced by increasing the interval between TDR, which means less TDR per lactation.

In this study, MY curves for individual lactations were typical lactation curves, except for the LG model in the low yielding milking doe which predicted the highest MY at the start of lactation, an steady stage of production between days 60 and 160 and a more rapid decrease in production post-day 200. The LG model showed a more changing shape of curve along the lactation in both the high and low yielding does curves than the other models. This could also mean that the third degree LG model used in this study is more flexible than the other models and the shape could differ from other models trajectories.

Model fitness

Four fit statistics (r^2 , CCC, RPE and AIC) values were used to evaluate how well the predicted yields fitted to the observed data. The selection of the best model may vary from one fit statistic to another (Khan 2009; Motulski & Christopoulos 2003; Val-Arreola et al. 2004). However, choosing the best model to describe milk traits in the

population should be based on the fit statistic to best describe the fitness of a model to accurately predict what is happening in the actual data. The “best” of the four fit statistics should be chosen based on the statistical properties of the fit statistics.

The coefficient of determination (r^2) is a quantitative index of association, or covariation between observed and model-predicted data. It is a measure of how well the model fits as a predictor of the observed data. The r^2 measures the variance not accounted for in the model and therefore measures the relative sizes of the total sum of squares and the sum of squares of deviations between the predicted and the observed data. The smaller the deviations between the observed and predicted data the more reliable the predictions obtained from the model.

The CCC is an omnibus fit statistic that combines measures of both precision and accuracy to determine how far the observed data deviate from the line of perfect concordance, that is, the line at 45 degrees on a square scatter plot (Lin 1989; Lin 2000). This is how far the fitted linear relationship of two variables for example X and Y, deviates from the concordance line (accuracy) and how far each observation deviates from the fitted line (precision) (Crawford et al. 2007).

The relative prediction error (RPE) is a measure of the dispersion of the predicted data from the actual values. The relative error to the mean of the actual data values is sometimes a more meaningful measure of performance of a predictor than the absolute error (Park & Stefanski 1998). Fuentes-Pila et al (1996) proposed that values under 10% imply a satisfactory prediction, between 10-20% indicated a relatively good prediction and over 20% indicates an unsatisfactory prediction. For this study all predictions were under 10% which indicates a satisfactory prediction of lactation trait curves and yield.

Akaike information criterion (AIC) was one of the first fit statistics methods used to select a model (Akaike 1974). It selects a model that minimizes the expected error of the new observation with the same distribution as the data used for fitting. The AIC combines the maximum likelihood (data-fitting) and the choice of model, by penalising the (log) maximum likelihood with a term related to the number of parameters in the model (Akaike 1974; Val-Arreola et al. 2004).

Using these models of fitness, two out of the four fit statistics (r^2 and AIC) showed better values for the LG model than for the other three models for milk yield curves,

while RPE was lower for the WK model for FY and PY and lower for the LG model for MY.

CCC values were similar between the LG and WK models followed by the WD and AS models. For the FY curves the WK, LG and AS models presented higher values for CCC. Higher values for r^2 were observed for the LG and WK models, but higher values of RPE were calculated for the WK and LG models and lowest AIC values for the LG model followed by WK model. For the PY curves, the WK model had the best values for three out of the four fit statistics (r^2 , RPE and CCC).

When using several fit statistics to select a suitable mathematical model to represent lactation curves, one approach is to use the most consistent fit statistics across traits and models. Using this approach, the r^2 and CCC fit statistics showed the WK and LG models were consistently best for MY and FY, while the AS, WK and LG models were best for FY and PY. AIC suggested the LG model was best for MY and FY, but that the WK model was better for PY. RPE values were lower for the WK model for MY and PY, while a lower value was observed for MY using the LG model, which agree with the trend of the values of r^2 and CCC.

Burnham & Anderson (2004) suggest that AIC values are the most critical to evaluate the goodness of fit of different mathematic models to the raw data. The differences in AIC values were not important between the LG and WK models for MY, FY and PY. AIC values for the LG and WK models were much greater compared to the AS and WD models, suggesting they were better models. Further supporting evidence estimated from AIC values is presented in Appendix 4.2.

An alternative approach is to select the mathematical model based on the overall ranking for each fit statistic across models, within trait; however this required the estimation of common factors among all models which was not examined here. The non-significant differences between the LG and WK models suggested that both models can used to describe the lactation curves of daily yields of milk, fat and protein. However due to the fact that the WK model showed an overall better performance for the other three fit statistics, it has less number parameters to estimate, was developed for indoor production animals (Wilmink et al. 1987a) and that the LG model tended to be more affected by TDR at start and end of lactation period (Silvestre et al. 2006), the WK

model was chosen as the best model to describe the lactation curves of daily yields of milk, fat and protein for indoor New Zealand dairy goats.

CONCLUSIONS

The mathematical functions using RRM considered in this study to model the lactation curves of milk traits of New Zealand dairy goats were able to represent different shapes of lactation curves with high measures of fit. The best model to predict milk yield and fat was the LG model, while for protein lactation curves it was the WK model. There were not significant differences between both models. On an overall performance basis for indoor dairy goats the WK model will be used for lactation trait predictions. Further studies are needed to determine specific characteristics of the lactation curves for each breed group and lactation number involved in the New Zealand dairy goat population.

APPENDICES OF CHAPTER 4

Appendix 4.1. Correlation matrices between the parameters¹ of the four mathematical functions for milk, fat and protein yield in New Zealand dairy goats.

Model	Parameter	Milk yield			Fat yield			Protein yield					
		α_0	α_1	α_2	α_3	α_0	α_1	α_2	α_3	α_0	α_1	α_2	α_3
Legendre	α_0												
	α_1	-0.18			-0.28			-0.2					
	α_2	-0.41	0.06		-0.34	0.09		-0.38	0.05				
	α_3	-0.001	-0.08	-0.06	-0.07	-0.09	-0.14	-0.04	-0.07	-0.08			
Wilink	Parameter	a	b	c	a	b	c	a	b	c			
	a		-0.92	-0.71	-0.76	-0.52		-0.67	-0.72				
	b			0.38	-0.03				0.11				
Ali & Schaeffer	Parameter	a	b	c	d	e	a	b	c	d	e		
	a		0.45	-0.63	-0.96	-0.63	-0.6	-0.7	-0.98	0.21			
	b			0.41	-0.18	-0.97	0.59	-0.2	-0.75				
	c				0.82	-0.2	0.71	-0.98					
	d					0.39							
Wood	Parameter	a	b	c	a	b	c	a	b	c			
	a		-0.37	0.41	-0.99	0.99		0.4	-0.49				
	b			-0.78	-0.98				-0.21				

¹Parameters were defined previously.

Appendix 4.2. Regression coefficients (β_0 and β_1), Akaike information criteria (AIC), differences between AIC (Diff), odd ratio (OR) and Akaike weights (AW) for milk (MY), fat (FY) and protein (PY) yield traits using four mathematical models in New Zealand dairy goats.

Model ¹	No.	Milk yield			Fat yield			Protein yield			AIC			Diff			OR			AW		
		β_0	β_1	β_0	β_1	β_0	β_1	β_0	β_1	MY	FY	PY	MY	FY	PY	MY	FY	PY	MY	FY	PY	
LG	4	0.26	0.91	0.01	0.87	0.01	0.84	-11957.6	-10676.2	-10428.0	0.0	0.0	0.4	5.47	3.00	7.39	0.53	0.41	0.40			
WK	3	0.35	0.88	0.02	0.85	0.01	0.89	-11956.2	-10676.0	-10428.4	1.4	0.2	0.0	2.72	2.72	9.03	0.26	0.38	0.49			
AS	5	0.37	0.83	0.02	0.77	0.02	0.80	-11954.6	-10672.7	-10424.3	3.0	3.5	4.1	1.22	0.52	1.19	0.12	0.07	0.06			
WD	3	0.36	0.86	0.03	0.70	0.01	0.83	-11954.2	-10674.0	-10424.0	3.4	2.2	4.4	1.00	1.00	1.00	0.10	0.14	0.05			

¹Models are: LG is Legendre model, WK is Wilmlink model, AS is Ali & Schaeffer model, and WD is Wood model. ²Number of parameters in the model.

Appendix 4.3. Number of typical and atypical lactation curves in the test-day data and lactations for milk, fat and protein yield using four mathematical models in New Zealand dairy goats.

Modelo	Parameter			Milk yield			Fat yield			Protein yield			
	b0	b1	b2 b3	Typical	Atypical	Number of Lactations	Typical	Atypical	Number of Lactations	Typical	Atypical	Number of Lactations	
Legendre	+	+	+	2804	850	2386	663	3855	1071				
	+	+	-	2093	566	2781	773	3461	961				
	+	+	-	5956	1598	2914	809	5611	1559				
	+	-	-	37554	9654	26883	7468	31243	8679				
	+	-	+	56016	16689	30246	8402	45047	12513				
	+	-	+	24527	6802	38231	10620	32217	8949				
	+	+	-	7588	2272	2573	715	6419	1783				
	+	-	+	18446	4881	47966	13324	25126	6979				
				Subtotal	82050	72934	43311	2573	151407	42772	88320	64659	42494
				Total		154984			153980			152979	
Wilmlink	a	b	c										
	+	+	+	26	17	415	115	149	41				
	+	+	-	619	192	90428	25219	17117	4655				
	+	-	+	2191	698	1486	413	3088	858				
			Subtotal	152148	42404	61655	17026	133128	36880				
			Total		154984			153984			153482		
Ali & Schaeffer	a	b	c	d	e								
	+	-	+	-	-	3409	975						
	+	-	+	-	+	67	31						
	+	-	-	-	-	12317	3441						
	+	-	-	-	+	139191	38864						

...Continuation Appendix 4.3.

	+	-	-	+	-	133250	37014	1240	344
	+	-	-	+	+				
						21734	6037		153744
						21734	43051	1240	42707
						154984			43051
						154984			154984
Subtotal									
						43311			
Total									
						154984			
Wood									
	a	b	c						
	+	+	+			753			
	+	+	-			169			
	+	-	-			200			
	+	-	+			124063			
	-	+	+			256			
	-	-	+			29505			
	-	+	-			8			
	-	-	-			6			
	-	-	-			30			
						43311			
						154182			
						0			
						151435			
						154182			
						154182			
Subtotal									
						30744			
Total									
						154984			
						154182			
						151435			
						2453			
						153888			
						154182			
						42828			
						151435			
						2453			
						153888			
						1195			
						1194			
						64			
						18			
						332			
						42065			
						332			
						42828			
						151435			
						1195			
						1194			
						64			
						18			
						332			
						42065			
						332			
						42828			
						151435			
						2453			
						153888			
						154182			
						42828			
						151435			
						2453			
						153888			

CHAPTER 5
MODELLING OF LACTATION TRAIT CURVES FOR NEW ZEALAND
DAIRY GOATS USING RANDOM REGRESSION MODELS:
LACTATION TRAIT CURVES BY BREED GROUP AND LACTATION
NUMBER

ABSTRACT

Ten dairy goat breed groups and five lactation periods were identified from 18,796 milking does contributing to 43,503 lactations in 35 herds from the Waikato region of New Zealand. The data was analysed using random regression models (RRM) to calculate individual model parameters and predict the average lactation curves for milk (MY), fat (FY) and protein yield (PY) by breed group (BG) and lactation number (LN). Lactation yield traits were predicted using the Wilmink model (WK) and the concordance correlation coefficient (CCC) was utilised to indicate the goodness of fit. The BGs were eight Saanen-based breed groups, Toggenburg (T) and other breed groups (OB=Alpine, Nubian or unknown breed or T composition). A subset of the five BGs with more numerous test-day records (TDR) was chosen to be described as well as the five lactations. The model parameters a, b and c associated with the intercept (initial trait yield, ascending phase of the curve to peak and declining phase of the lactation curve, respectively) of Wilmink model for each trait were estimated. Average observed MY, FY and PY production levels were higher in crossbred groups than in purebred groups. The highest lactation curve performance for all traits was for S75 (3/4Saanenx1/4OB) and the lowest for T, while the other BGs performed intermediate. Saanen and T breeds also differed significantly for all traits ($p < 0.05$). Model parameter values for lactation number differed significantly for all traits ($p < 0.05$). While lactation three showed the highest curve performance, lactation one was with the lowest. The CCC estimates ranged from 0.89 in S75 for MY and FY to 0.95 in S25 for all traits, while for LN the CCC values ranged from 0.74 for MY in lactation 5 to 0.96 for PY in lactation 3. Values of CCC suggested that RRM and the WK can be used to model lactation trait yields for different breed groups and lactations. The crossbred groups performance agreed with a previous study on heterosis effects using first cross breeds; however, further studies are need involving all crossbred groups identified in this study. Furthermore, a more rigorous individual identification system in farms is recommended to reduce unknown breed group animal numbers. The use of RRM allows the modelling of lactation curves and the prediction of lactation yields for milk, fat and protein of dairy goats based on one or more TDR.

Keywords: Lactation curves, random regression models, Wilmink, dairy goats, breed groups.

INTRODUCTION

The New Zealand dairy goat industry is characterised by producing milk powder for export to niche markets. Milk-solids, for example fat and protein yield, are the base for milk powder production. These milk traits are the backbone in any genetic improvement programme for

dairy animals, however, when planning comprehensive genetic improvement programmes other productive (e.g. liveweight, total milk solids) and functional (e.g. Somatic cell count, fertility, longevity) traits need to be taken into account.

Milk is produced by mammals over a period of time follows a curvilinear shape and can be modelled using different mathematical models. This period of time is called the lactation period (Wood 1967). Wood described a typical lactation curve as occurring in different stages: initial production, ascending phase, maximum production point and descending phase. It is influenced by the growth and death of cells in the mammary gland during pregnancy and lactation (Dijkstra et al. 1997; Macciotta et al. 2005).

The shape of the lactation curve and factors affecting it, such as breed, lactation and season, should be accounted for in any plan for modern management and breeding strategies. They can also assist with the evaluation of the biological and economic efficiency of breeds, generations, groups of animals or individual animal production (Dudouet 1982; Grossman & Koops 1988). These assessments can help farmers and breeders in making management decisions, such as feeding, mating and culling, but also for estimating total lactation yield from incomplete records and forecasting herd performance on a time or individual animal basis (Sauvant 1988). Several mathematical models have been developed to describe a lactation curve for milk production in dairy cattle (Buttchereit et al. 2010; Jamrozik et al. 1997; Khan 2009; Silvestre et al. 2006) but not so for dairy goat lactation curves (Gipson & Grossman 1989b; Macciotta et al. 2008).

The limitation of using a few test-day records (TDR) (e.g. one or two) is a problem in accurately describing the lactation curve of dairy animals. In dairy cattle, random regression models (RRM) have been widely used for genetic evaluation (de Roos et al. 2004; Jensen 2001; Schaeffer 2004) and modelling of the lactation curve (Mayeres et al. 2004; Strabel et al. 2005). However, in dairy goats only one study has been conducted to estimate genetic (co)variance and breeding values throughout the first and second lactations (Menéndez-Buxadera et al. 2010), but (as far as the author is aware) not for modelling of the dairy goat lactation curve.

Random regression models enable the use of a small number of records to estimate model parameters for each milk trait curve and each milking doe. This allows the detection of differences in regression coefficients between groups of animals or individuals and within animals for the traits over a period of time (Kirkpatrick et al. 1990; Kirkpatrick et al. 1994). Individual regression coefficients make it possible to adjust the parameters for sources of

variation affecting the parameter values and to calculate milk, fat and protein curves based on one or more TDR per animal (Schaeffer, 2004). In the past, animals with just one record were left out of the analysis because it was not possible to predict a lactation curve for those animals. However, using RRM those records can now be included in a general random regression analysis and individual lactation curves estimated.

Some studies have described lactation curves for dairy goats in various countries (Fernández et al. 2002; González-Peña et al. 2012; Montaldo et al. 1997; Ruvuna et al. 1995). In Chapter 4 four mathematical functions (Legendre of order 3, LG; Wilmink, WK; Ali & Schaeffer, AS and Wood, WD) were explored to describe lactation curves in New Zealand dairy goats and four fit statistics were evaluated (coefficient of determination, r^2 ; concordance correlation coefficient, CCC; relative prediction error, RPE and Akaike information criteria, AIC). Based on AIC values the WK model was chosen as the best model. In this chapter the concordance correlation coefficient (CCC) was chosen to describe the fit of the lactation curve for MY, FY and PY per breed group and lactation number.

The objective of the present study is to estimate the performance of the lactation curve per breed group and lactation number in the dairy goat population using RRM, the WK model and CCC for New Zealand dairy goats.

MATERIALS AND METHODS

Data and dairy goat herd

A database was constructed using test-day records from 18,715 milking does from dairy goat farms supplying the New Zealand Dairy Goat Cooperative, Ltd (DGC). Table 5.1 shows that these milking does provided 43,311 parities representing 154,984 TDR from 35 herds and 10 breed groups for a 20 years period (1989 to 2009) from the Waikato region of New Zealand. The general features of the farming systems were described by Solis-Ramirez et al. (2011). Briefly, the herd structure consisted of 18.6% 0-1 year olds, 14.5% 1-2 year olds, 12.9% 2-3 year olds, 10.8% 3-4 year olds, 8.8% 4-5 year olds, 4.9% 5-6 year olds, 2.7% 6-7 year olds, 1.6% 7-8 year olds, 1.2% 8-9 year olds, 1.1 % 9-10 year olds, 0.9% 10+ year olds. The herd was 97.5% Saanen (S), or SaanenxToggenburg crosses and the remaining 2.5% were mainly British Alpine, Nubian and Saanen by British Alpine and Saanen by Nubian crosses. Milking goats kid once a year and they are milked twice a day for a range from 13 to 305 days in milk and an average lactation length of 227 days.

Breed and lactation groups

The data were sorted into Saanen-based, Toggenburg (T) and Other Breed groups (OB=Alpine, Nubian and unknown breed or T genetic composition). The eight Saanen-based breed groups were as follows: Saanen (S100), 7/8Saanen-1/8OB (S87), 6/8S-2/8OB (S75), 5/8S-3/8OB (S62), 4/8S-4/8OB (S50), 3/8S-5/8OB (S37), 2/8S-6/8OB (S25) and 1/8S-7/8OB (S12).

There were five lactation groups. The number of does with more than five lactations was very small, therefore, these were combined into lactation number five. A highly seasonal kidding period occurs between June and October. The small number of parities between January and May were added up to June parities, and the small number of parities between October and December were added up to October parities. Therefore, the kidding season was grouped into five months from June to October.

Although ten breed groups were considered, a subset of five out of the ten breed groups and five lactations was chosen to be presented and discussed in text (Table 5.1). The breed groups to be discussed were chosen according to the following criteria: 1) Pure breeds (S100 and T) and 2) those representing the more numerous Saanen groups or crosses (S100, S75, S50, S25).

The number of test-day records and number of milking does and lactations for the five breed groups are shown in Table 5.1. Data for all ten breed groups is presented in Appendix 5.1

Modelling of lactation curves

Random regression analysis

Test-day records for milk, fat and protein yield were analysed using RRM to calculate the polynomial regression coefficients for the Wilmink model (Wilmink 1987b) using the ASREML 3.0 software package (Gilmour et al. 2009).

The analysis of population lactation curves using RRM has been discussed previously in Chapter 4 and the structure of RRM was described by Schaeffer (2004). Briefly, RRM estimates the regression coefficients for each individual animal using one or more TDR from the average lactation trait curve of the population as a fixed curve and predicts trait performance using covariance functions between the fixed curve and test-day records of each milking doe. The covariance function is a continuous function to give the variance and covariance of traits measured at different points of a trajectory. The trajectory can be time or

any continuous variable, for example temperature. RRM first calculates estimates of regression coefficients of a fixed general lactation curve for the base population using all TDR available and then estimates random regression coefficients of lactation curve for a particular doe in a specific parity. These random regression coefficients for a particular doe-lactation are expressed as deviations from the population estimates. Using the estimates of the regression coefficients, daily yields can be calculated and summed to estimate total lactation yields or daily milk yields. If the (co) variance matrix between estimates of the random regression coefficients can be estimated with high accuracy using the (co) variance between TDR, then random regression coefficients can be estimated for each combination of doe-lactation. This technique provides the opportunity to calculate lactation yields even when an animal has only one TDR (Schaeffer 2004).

Wilmink model

Chapter 4 showed that the Wilmink and Legendre model of order 3 were the best models based on the AIC fit statistic to be used in milk trait prediction curves for New Zealand dairy goats. However, the WK model was chosen over the LG model after a general overview of the other three fit statistics. The Wilmink model is a combined exponential and linear model (Wilmink 1987b). The equation is:

$$Y_t = a + bt + (c)e^{-0.05t} + a_i + b_it + (c_i)e^{-0.05t} + \varepsilon_t$$

where:

a , b and c = fixed regression population coefficients;

a_i , b_i and c_i = random regression coefficients as deviation from the fixed population curve; and

e = natural logarithm base e ;

ε_t = experimental error associated with each observation at time t ; and

t = days in milk.

Fixed model parameters a , b , c and random individual parameters for each milking does a_i , b_i and c_i are associated with the initial level of production, the increase of production before the peak and with the subsequent decrease, respectively. Random error (ε_t) is assumed to be independent with normal distribution, zero mean and variance σ_e^2 .

Fit statistics

Chapter 4 considered four fit statistics for four mathematical models and WK and LG models were selected as the best models for the whole population based on the AIC values.

The splitting of the whole population into ten breed groups and five lactations allows the use of the CCC as the fit statistic to assess the fit of the WK model to each particular group. CCC values combine measures of both precision and accuracy to determine how far the observed data deviate from the line of perfect concordance, that is the line at 45 degrees on a square scatter plot (Lin 1989; Lin 2000). CCC was calculated per breed group and lactation number using SAS Version 9.3 (SAS, 2012) as:

$$CCC = \frac{2\sigma_{A,P}}{(\sigma_A^2 + \sigma_P^2) + (\bar{A} - \bar{P})^2}$$

where:

σ = covariance between trait values;

A = actual milk trait yield values;

P = predicted milk trait yield values;

σ_A^2 = variance for actual milk trait yield, and

σ_P^2 = variance of predicted milk trait yield.

\bar{A} = mean of actual values, and

\bar{P} = mean of predicted values.

The standard error of the CCC for each *i*-breed group or lactation number (SE(CCC)_{*i*}) was estimated according to Lin (1989) and Franklin et al.(2014) as:

$$SE(CCC)_i = \sqrt{\frac{1}{N-2} \left[\frac{(1-r^2)ccc^2(1-ccc^2)}{r^2} + \frac{4ccc^3(1-ccc)u^2}{r} - \frac{2ccc^4u^4}{r^2} \right]}$$

where:

N = number of observation per breed group or lactation number;

r^2 = coefficient of determination;

CCC = concordance correlation coefficient;

$$u = \frac{\bar{A} - \bar{P}}{(\sigma_A^2 \sigma_P^2)^{0.5}}, \text{ where, } \bar{A} = \text{mean of the actual lactation trait values; } \bar{P} = \text{mean of the predicted lactation trait values, and } \sigma_A^2 \text{ and } \sigma_P^2 \text{ were defined previously.}$$

Table 5.1. Number of test-day records, number of milking does per breed group and per lactation number.

Breed group ¹	Test-day records	Number of does	Lactation number	Test day-records	Number of does	Number of lactations
Saanen (S100)	81891	10197	1	30000	8646	8646
			2	20305	5654	5654
			3	13773	3844	3844
			4	9010	2518	2518
			5	8803	1418	2524
Toggenburg (T)	4866	663	1	1765	547	547
			2	1493	434	434
			3	713	195	195
			4	414	120	120
			5	481	84	131
75%S,25%OB (S75) ¹	14918	1477	1	4594	1253	1253
			2	3701	1012	1012
			3	2710	736	736
			4	1908	529	529
			5	2005	317	585
50%S,50%OB (S50)	30540	3502	1	10558	2888	2888
			2	8515	2305	2305
			3	5382	1458	1458
			4	3412	1031	931
			5	2673	407	766
25%S,75%OB (S25)	6883	965	1	2901	779	779
			2	1960	527	527
			3	1162	312	312
			4	565	154	154
			5 ⁺	295	53	90
Others groups	15886	1911		15886	4241	4373
Total	154984	18715		1549848	41462	43311

¹for example for 75%Sannen and 25%OB (OB= British Alpine+Nubian+Unknown breed or T).

⁺Number of does with more than 5 lactations was added up to this lactation number.

Statistical analysis

A linear model was used to estimate the least square means for each parameter of the mathematical model by breed group and lactation number using PROC MIXED of SAS Version 9.3 (SAS, 2012). The statistical model was:

$$y_{ijkl} = \mu + h_l + \tau_k + \rho_j + \delta_i + \varepsilon_{ijkl}$$

where:

y_{ijkl} = a random regression coefficient for a milking doe of a breed group i ($i = 1, \dots, 10$), lactation number j ($j = 1, \dots, 5$), year k ($k = 1, \dots, 20$) and herd l ($l = 1, \dots, 35$);

μ = population mean;

h_l = effect of the l -herd ($l=1, \dots, 35$)

τ_k = fixed effect of the k -year ($k=1989, \dots, 2009$);

δ_i = fixed effect of the i -breed group ($i=1, 2, \dots, 10$);

ρ_j = fixed effect of the j -lactation number ($j=1, 2, \dots, 5$); and

ε_{ijkl} = random error inherent to each y_{ijkl} observation.

Random errors (ε_{ijkl}) were assumed to be independent and normally distributed with $\mu = 0$ and variance = σ_e^2 .

RESULTS

Breed groups

The least square means (LSM) for the model parameters and the level of significance for a subset of five breed groups for the traits studied are presented in Table 5.2. Results for the ten breed groups are presented in Appendix 5.2. The lactation curves for MY, FY and PY for the five breed groups and the five lactations are presented in Figure 5.1 and Figure 5.2, while lactation curves for ten BGs are presented in Appendix 5.3.

A typical milk yield curve can be observed in Figure 5.1. Comparatively S75 and T have the highest and lowest peak of production, respectively. S75 has the highest peak due to highly

significant values ($p < 0.05$) of the intercept (a) and the parameter affecting the ascending phase (b). T has the lowest peak due to the lowest intercept (a) and ascendant phase (b). S100, S50 and S25 presented intermediate MY curves and production between S75 and T.

An atypical lactation curve for FY was observed with a peak of production at the start of the lactation and a constant decline from the first day of lactation (Figure 5.1). Highly significant values ($p < 0.05$) were observed for the intercept (a) and the parameter affecting the descending phase (c). Breed group T had the lowest fat yield curve due to the lowest intercept (a) and descendant phase (b). In a similar manner than for MY, S100, S50 and S25 presented an intermediate FY curves between S75 and T.

A typical protein yield curve can be observed in Figure 5.1. Values for PY presented in Table 5.2 indicated that breed groups S75 and T had the highest and lowest peak of protein production, respectively. S75 had the highest parameter values and highly significant values among breed groups ($p < 0.05$) for the intercept (a), the ascendant phase (b) and the descendent phase (c) resulting in S75 having the highest peak. T had the lowest peak due to having the lowest intercept (a), ascendant phase (b) and descendent (c) parameters. Breed groups S100, S50 and S25 showed intermediate PY curves between S75 and T.

Parity number

The LSM for model parameters and level of significance for the five parities for the traits studied are presented in Table 5.2. The lactation curves for MY, FY and PY for all parities are presented in Figure 5.2.

Consistent and significant differences among all parities were observed for the three traits ($p < 0.05$). Milking does in parity 3 displayed the highest milk, fat and protein yield curve due to having the highest intercept values (parameter a), the highest ascendant value (parameter b) and the lowest decay value (parameter c), while the opposite was estimated for parity 1.

Fit statistics

The estimated CCC values their standard errors and levels of significance between actual milk, fat and protein yield at actual lactation length and predicted to actual lactation length for five breed groups and lactation number are presented in Table 5.3, while the estimates of the CCC for the ten breed groups are presented in Appendix 5.2. CCC values across traits were significantly different among most of the breed groups ($p < 0.05$), except between S50 and T, for

MY and FY and between S100 and S75 in PY and ranged from 0.88 for S75 in traits MY and FY to 0.94 for S25 in all traits. Model performance within lactations across traits showed significant differences among all parities and milk traits and ranged from 0.73 for MY in lactation 5 to 0.95 for PY in lactation 3.

Table 5.2. Least square means (and standard errors) of estimates of regression coefficients of the Wilmlink model for milk (MY), fat (FY) and protein (PY) yield model parameters (standard error) for 5 breed groups and five lactations in New Zealand dairy goats.

Trait	Para-Meter ¹	Breed group ²				
		S100	S75	S50	S25	T
Milk yield (MY)	<i>a</i>	4.22 ^m (0.033)	4.30 ^v (0.034)	4.15 ^x (0.034)	4.18 ^y (0.036)	3.98 ^z (0.038)
	<i>b</i>	-2.14 ^m (0.025)	-2.29 ^v (0.0262)	-2.13 ^m (0.026)	-2.17 ^m (0.027)	-1.88 ^x (0.028)
	<i>c</i>	-0.01 ^m (4x10 ⁻⁵)	-0.01 ^m (5x10 ⁻⁵)	-0.01 ^m (5x10 ⁻⁵)	-0.01 ^m (3x10 ⁻⁵)	-0.01 ^m (5x10 ⁻⁵)
Fat yield (FY)	<i>a</i>	13.80 ^m (0.114)	14.01 ^v (0.118)	13.65 ^x (0.116)	13.71 ^{mx} (0.124)	13.42 ^y (0.130)
	<i>b</i>	-0.03 ^m (2x10 ⁻⁵)	-0.03 ^m (2x10 ⁻⁵)	-0.03 ^m (2x10 ⁻⁵)	-0.03 ^m (1x10 ⁻⁵)	-0.03 ^m (1x10 ⁻⁵)
	<i>c</i>	1.15 ^m (0.066)	0.85 ^v (0.069)	1.05 ^x (0.068)	0.93 ^x (0.072)	1.53 ^y (0.076)
Protein yield (PY)	<i>a</i>	11.81 ^m (0.089)	10.60 ^v (0.108)	12.01 ^x (0.093)	11.70 ^m (0.091)	11.75 ^m (0.098)
	<i>b</i>	-0.02 ^m (1x10 ⁻⁵)	-0.02 ^m (3x10 ⁻⁵)	-0.02 ^m (1x10 ⁻⁵)	-0.02 ^m (2x10 ⁻⁵)	-0.02 ^m (2x10 ⁻⁵)
	<i>c</i>	-2.33 ^m (0.063)	-1.61 ^v (0.076)	-2.69 ^x (0.065)	-2.40 ^m (0.064)	-2.54 ^y (0.069)
		Lactation number				
		1	2	3	4	5 ⁺
MY	<i>a</i>	3.34 ^m (0.033)	4.18 ^v (0.034)	4.50 ^x (0.034)	4.44 ^x (0.035)	4.28 ^z (0.035)
	<i>b</i>	-1.56 ^m (0.025)	-2.20 ^v (0.025)	-2.42 ^x (0.026)	-2.31 ^y (0.026)	-2.12 ^z (0.026)
	<i>c</i>	-0.00 ^a (4x10 ⁻⁵)	-0.00 ^v (3x10 ⁻⁵)	-0.01 ^x (4x10 ⁻⁵)	-0.01 ^x (5x10 ⁻⁵)	-0.01 ^x (3x10 ⁻⁵)
FY	<i>a</i>	10.94 ^m (0.115)	13.97 ^v (0.117)	14.97 ^x (0.118)	14.75 ^x (0.120)	14.04 ^z (0.121)
	<i>b</i>	-0.02 ^m (1x10 ⁻⁵)	-0.03 ^v (2x10 ⁻⁵)	-0.03 ^x (4x10 ⁻⁵)	-0.03 ^x (1x10 ⁻⁵)	-0.03 ^x (2x10 ⁻⁵)
	<i>c</i>	1.51 ^m (0.067)	0.91 ^v (0.068)	0.60 ^x (0.069)	1.00 ^y (0.070)	1.40 ^z (0.070)
PY	<i>a</i>	9.41 ^m (0.090)	11.78 ^v (0.091)	12.76 ^x (0.092)	12.51 ^x (0.094)	12.04 ^z (0.094)
	<i>b</i>	-0.01 ^m (2x10 ⁻⁵)	-0.02 ^v (1x10 ⁻⁵)	-0.02 ^x (2x10 ⁻⁵)	-0.02 ^x (1x10 ⁻⁵)	-0.02 ^x (2x10 ⁻⁵)
	<i>c</i>	-1.42 ^m (0.063)	-2.60 ^v (0.064)	-3.05 ^x (0.065)	-2.66 ^y (0.066)	-2.18 ^z (0.066)

^{m,v,s,x,y,z}Different letters within the same row show significant differences between the means of breed groups or lactation number (p<0.05). ²Breed groups were Toggenburg (T) or Saanen based group, e.g:S75=Saanen 75%-Other breeds (OB) 25%. OB were: British Alpine + Nubian + Unknown breed or T. ⁺Number of does with more than 5 lactations was added up to this lactation number. ¹Letters stand for model parameters.

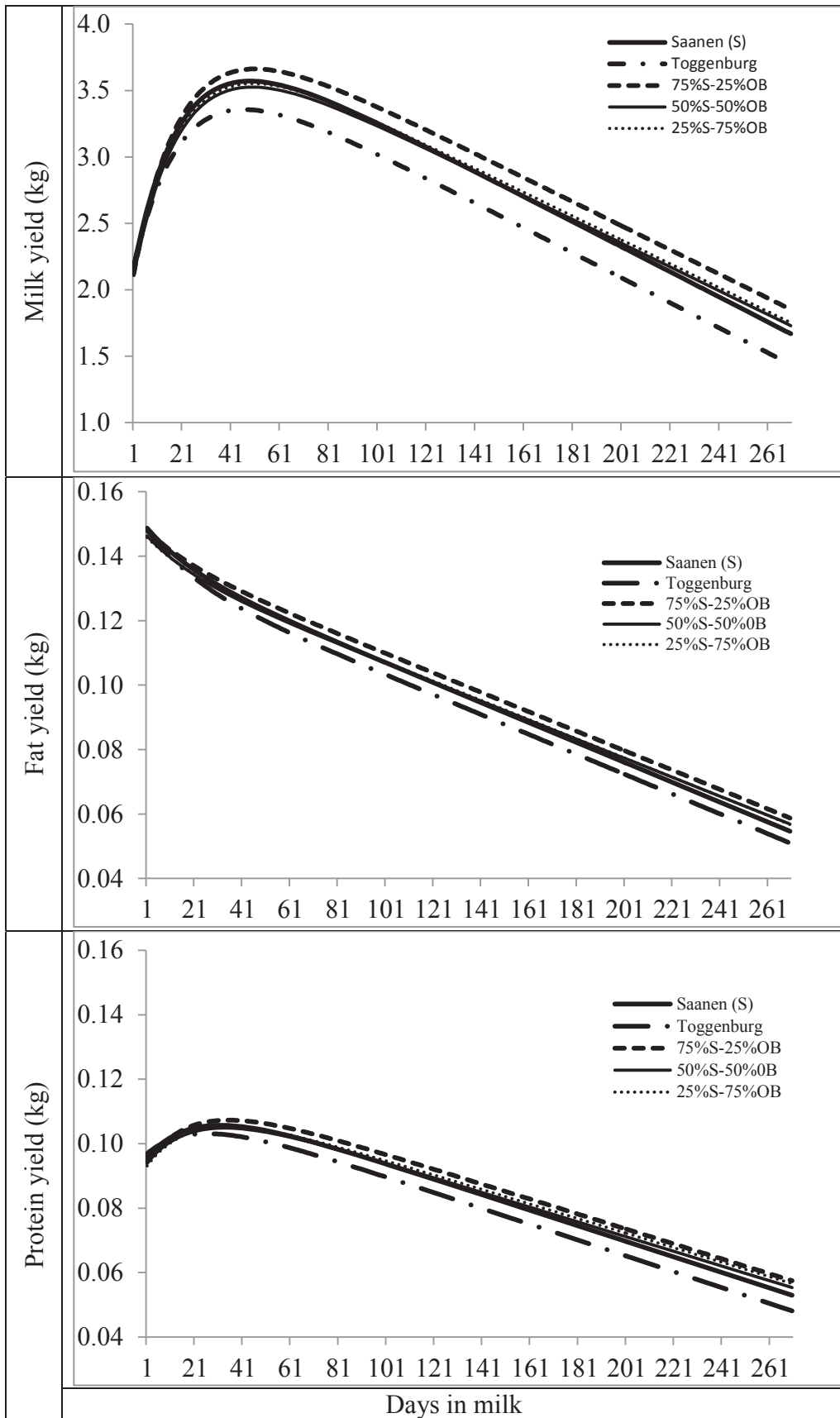

Figure 5.1. Milk, fat and protein yield curves for five breed groups in New Zealand dairy goats.

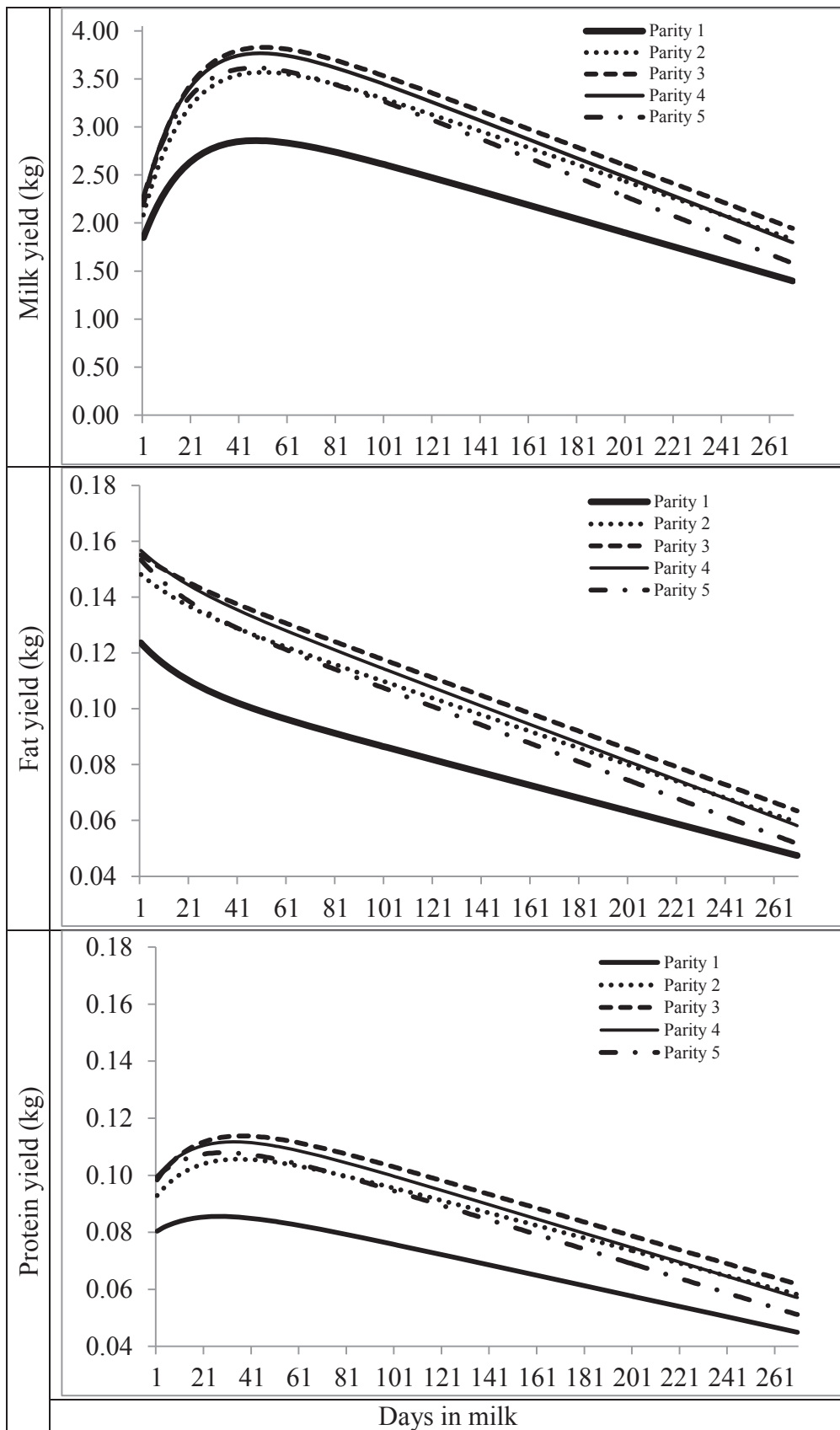

Figure 5.2. Milk, fat and protein yield curves per lactation number in New Zealand dairy goats.

Table 5.3. Concordance correlation coefficient (and standard errors) for daily milk (MY), fat (FY) and protein (PY) yield curves using the Wilmink model and levels of significance for 5 breed groups and five lactations of New Zealand dairy goats.

Breed group ¹	Trait		
	MY	FY	PY
S100	0.89 ^m (0.001)	0.89 ^m (0.001)	0.90 ^m (0.001)
S75	0.88 ^v (0.004)	0.88 ^v (0.005)	0.90 ^m (0.004)
S50	0.92 ^x (0.001)	0.92 ^x (0.001)	0.93 ^v (0.001)
S25	0.94 ^y (0.001)	0.94 ^y (0.001)	0.94 ^y (0.001)
T	0.92 ^x (0.002)	0.92 ^x (0.002)	0.92 ^x (0.002)
Lactation number			
1	0.87 ^m (6x10 ⁻⁴)	0.87 ^m (0.002)	0.87 ^m (0.002)
2	0.93 ^v (3x10 ⁻⁴)	0.93 ^v (0.001)	0.93 ^v (0.001)
3	0.94 ^x (3x10 ⁻⁴)	0.94 ^c (4x10 ⁻⁴)	0.95 ^x (4x10 ⁻⁴)
4	0.89 ^y (0.001)	0.90 ^y (0.001)	0.89 ^y (0.001)
5	0.73 ^z (0.002)	0.74 ^z (0.003)	0.74 ^z (0.003)

^{m,v,x,y,z} Different letters in same trait showed significant differences between breed group or lactation number ($p < 0.05$). ¹Breed groups were Toggenburg (T) or Saanen based group, e.g:S75=Saanen 75%-O 25%. O were: British Alpine + Nubian + Unknown breed or T.

DISCUSSION

Lactation curves

The technique of random regression allows the estimation of individual lactation curves when one or more records are available for a whole lactation. The author is not aware of any previously published papers using RRM to estimate lactation curves for individual, population or different breed groups and lactations in dairy goats. However, there are numerous reports for dairy cattle (Jensen 2001; Schaeffer et al. 2000; Schaeffer 2004; Swalve 2000) due to the increase in precision and accuracy to predict milk trait curves compared with other methodologies, for example, the repeatability test-day animal model fitting the intercept in modelling lactation performance. A brief description of the main differences between repeatability test-day models and random regression models was presented by Schaeffer & Jamrozik (2008).

It was anticipated that differences in model parameters would be reflected in significant differences in production performance among BGs and LN (Wilmink 1987b). The estimated curves showed a major difference between the S75 and T breed groups, with other BGs

performing between S75 and T. For MY and PY, the ascending phase was similar between BGs, except for S75 for MY, which agrees with the parameter values in Table 5.2. Parameter *c* is related to the decay of the MY lactation curve and was similar for all BGs, but decay of daily production between BGs for FY and PY was different ($p < 0.05$). This means that the decay of milk yield is similar, while the decay in FY is faster than the decay in PY. These results suggested important differences in milk-solids production from the start to the end of lactation with protein being more produced at the end of lactation than fat.

The LSM of the MY, FY and PY model parameters were significantly different between purebreds and crossbred groups ($p < 0.05$); in addition average crossbred groups performed higher than average purebreds. Similar results were reported for dairy goats in smallholder production systems in Kenya for local breeds, F1 and backcrosses using the Wood model (Bett et al. 2011). Bett et al. (2011) reported that crossbreds had higher daily milk yields than purebred goats.

For lactation number, the estimated curves showed a major difference between lactation 3 and lactation 1, with other lactations performing between lactation 3 and lactation 1. The highly significant differences in model parameters between parities are expected to be reflected in the levels of production. The highest intercept values, fastest ascending phase and lowest decay were observed for lactation number three, followed by lactations 4, 2, 5 and 1. However, there were no differences between lactations 3 and 4 for most of the model parameters. As was stated before, the author is not aware of any published papers related to lactation curves per lactation number using RRM and the Wilmink model, but similar results were estimated in dairy goats using different mathematical models in Spain (Fernández et al. 2002; León et al. 2012). Furthermore, the least square means for MY, FY and PY in this study were similar to the average production levels of milking does under indoor conditions from other countries (García-Peniche et al. 2012; González-Peña et al. 2012; Montaldo et al. 2010; Ribas & Gutierrez 2001; Torres-Vazquez et al. 2009, 2010a), but higher than the previous values reported by Morris et al. (2006) from a New Zealand herd. Differences between the values in this study and the values presented by Morris et al. (2006) for another New Zealand dairy herd could be due to the size of the data base and to the previous selection background for milk yield in the herds.

In this study, an important and significant breed effect was detected between the Saanen and Toggenburg breeds ($p < 0.05$) and between these breeds and S75 for all traits ($p < 0.05$). Similar

performances were observed between S100 and S50 for all traits, and also between S100 and S25 for the predicted values of FY and PY, indicating differences in the crossbred effects between groups. These results agree with a previous study for by Singireddy et al. (1997) pointing out a heterosis effect for first crosses of Saanen breed in this population.

These results indicating heterosis effects on milk due to multi-breed genes in the crossbred milking does were previously highlighted by Singireddy et al. (1997) for Saanen first crosses with the same breeds as this study, but with a smaller data base size. However, the greater data base size and the greater number of types of crosses in this study suggest the need of further investigation on individual and maternal heterosis effects involving all crossbred groups in the population. Another aspect to account for in this breed group's performance is the high number of milking does without identification in the unknown breed group. This fact suggests the probability of higher numbers of Saanen genes in the crossbred groups due to a poor identification system, and therefore, those milking does could be performing differently than expected.

Concordance correlation coefficient (CCC)

Estimated values for CCC were significantly different within trait among breed groups except for the first cross between SaanenxOB (S50) and T for the three traits. However, higher CCC values were found in the BG data than when analysing the lactation number data, which could be due to the number of observations per breed group and parity number. It is very likely that the number of observations was large enough to provide with an accurate estimation of CCC values since the standard errors are small. Breed group S100 has the greatest number of observations, but not the higher CCC values, in a similar way a breed group with a lower number of observations did not have the lower CCC value for example, breed T. In the case of parity number, the highest number of TDR was for parity 1 and the lowest for parity 5, but parity 2 has a lower number of data than parity 1 and the CCC is higher than the CCC of parity 1. Therefore, there is not a clear association showing the effect of number of observations on the CCC estimations. But it was expected that the higher number of observations would tend to reduce the standard error. Other studies with less data than the present study present similar values to those found in this study and the CCC values were within the range reported in the literature for the prediction of lactation curves for dairy cattle (Khan 2009; Macciotta et al. 2005) and dairy goats (Fernández et al. 2002; González-Peña et al. 2012).

CONCLUSION

Model parameters varied with breed group and lactation number. Lactation 3 showed the highest lactation curve of milk, fat and protein, while lactation 1 yielded the lowest values. The CCC values estimated from a large and wide range of number of observations per breed group and parity number are high and were of similar magnitude between breed groups and traits, but more variable values were observed among lactations. Crossbred groups had similar or higher model parameter values for MY, FY and PY than purebred Saanen and Toggenburg does suggesting the need for further research for heterosis effects involving all breed groups identified in this study. It is suggested a more rigorous individual identification system in farms be established to enable the reduction of the number of animals in the unknown breed group. RRM allowed the use of one or more TDR for the modelling of lactation curves of dairy goats.

APPENDICES TO CHAPTER 5

Appendix 5.1. Number of test-day records, number of milking does per breed group and per lactation number.

Breed group ¹	Test-day records	Number of does	Lactation number	Test-day records	Number of does	Number of lactations
Saanen (S)	81891	10197	1	30000	8646	8646
			2	20305	5654	5654
			3	13773	3844	3844
			4	9010	2518	2518
			5	8803	1418	2524
Toggenburg (T)	4866	663	1	1765	547	547
			2	1493	434	434
			3	713	195	195
			4	414	120	120
			5	481	84	131
Other breeds (OB)	2627	313	1	1075	272	272
			2	693	169	169
			3	454	106	106
			4	212	48	48
			5	193	25	44
87.5%S,12.5%OB ¹	6092	703	1	2111	623	623
			2	1451	416	416
			3	1073	295	295
			4	867	233	233
			5	590	99	165
75%S,25%OB	14918	1477	1	4594	1253	1253
			2	3701	1012	1012
			3	2710	736	736
			4	1908	529	529
			5	2005	317	585
62.5%S,37.5%OB	3016	336	1	1118	308	308
			2	779	222	222
			3	525	144	144
			4	339	94	94
			5	255	46	74
50%S,50%OB	30540	3502	1	10558	2888	2888
			2	8515	2305	2305
			3	5382	1458	1458
			4	3412	1031	931
			5	2673	407	766
37.5%S,62.5%OB	2203	292	1	904	255	255
			2	606	175	175
			3	383	111	111
			4	184	54	54
			5	126	28	39

...continuation Appendix 5.1.

25%S,75%OB	6883	965	1	2901	779	779
			2	1960	527	527
			3	1162	312	312
			4	565	154	154
			5	295	53	90
12.5%S,87.5%OB	1948	267	1	768	209	209
			2	564	154	154
			3	374	97	97
			4	166	46	46
			5	76	12	20
Total	154984	18715		154984	41462	43311

¹Breed groups were Saanen based percentage with remainder breed percentage being from any other breeds or T (OB), e.g:S75=Saanen 75%-OB 25%. OB were: British +Alpine + Nubian + Unknown or T.

Appendix 5.2. Least square means, standard errors and significance levels for model parameters of milk yield, fat yield and protein yield for 10 breed groups of New Zealand dairy goats.

Breed Group ¹	Trait/parameter								
	Milk yield (MY)			Fat yield (FY)			Protein yield (PY)		
	a	b	c	a	b	c	a	b	c
S100	4.22 ^m (0.033)	-2.14 ^m (0.025)	-0.01 ^m (4x10 ⁻⁵)	13.80 ^m (0.114)	-0.03 ^m (2x10 ⁻⁵)	1.15 ^m (0.066)	11.81 ^m (0.089)	-0.02 ^m (1x10 ⁻⁵)	-2.33 ^m (0.063)
S87	4.37 ^s (0.036)	-2.34 ^s (0.027)	-0.01 ^m (2x10 ⁻⁵)	14.30 ^v (0.124)	-0.03 ^m (1x10 ⁻⁵)	0.77 ^s (0.072)	11.44 ^s (0.102)	-0.02 ^m (4x10 ⁻⁵)	-1.82 ^s (0.071)
S75	4.30 ^t (0.034)	-2.29 ^s (0.026)	-0.01 ^m (5x10 ⁻⁵)	14.01 ^t (0.118)	-0.03 ^m (2x10 ⁻⁵)	0.85 ^t (0.069)	10.60 ^t (0.108)	-0.02 ^m (3x10 ⁻⁵)	-1.61 ^s (0.076)
S62	4.25 ^m (0.040)	-2.21 ^s (0.030)	-0.01 ^m (1x10 ⁻⁵)	13.98 ^t (0.135)	-0.03 ^m (1x10 ⁻⁵)	0.98 ^v (0.079)	12.14 ^v (0.097)	-0.02 ^m (5x10 ⁻⁵)	-2.78 ^t (0.068)
S50	4.15 ^v (0.034)	-2.13 ^m (0.026)	-0.01 ^m (5x10 ⁻⁵)	13.65 ^v (0.116)	-0.03 ^m (2x10 ⁻⁵)	1.05 ^v (0.068)	12.01 ^x (0.093)	-0.02 ^m (1x10 ⁻⁵)	-2.69 ^v (0.065)
S37	4.30 ^t (0.041)	-2.25 ^s (0.031)	-0.01 ^m (3x10 ⁻⁵)	14.01 ^t (0.141)	-0.03 ^m (3x10 ⁻⁵)	1.03 ^v (0.082)	11.92 ^x (0.106)	-0.02 ^m (3x10 ⁻⁵)	-2.54 ^x (0.075)
S25	4.18 ^x (0.036)	-2.17 ^m (0.027)	-0.01 ^m (3x10 ⁻⁵)	13.71 ^m (0.124)	-0.03 ^m (1x10 ⁻⁵)	0.93 ^v (0.072)	11.70 ^m (0.091)	-0.02 ^m (2x10 ⁻⁵)	-2.40 ^x (0.064)
S12	4.10 ^v (0.042)	-2.11 ^m (0.032)	-0.01 ^m (8x10 ⁻⁵)	13.34 ^x (0.146)	-0.02 ^t (3x10 ⁻⁵)	1.03 ^v (0.085)	12.13 ^x (0.113)	-0.02 ^m (3x10 ⁻⁵)	-2.66 ^v (0.079)
T	3.98 ^y (0.038)	-1.88 ^t (0.028)	-0.01 ^m (5x10 ⁻⁵)	13.42 ^x (0.130)	-0.03 ^m (1x10 ⁻⁵)	1.53 ^x (0.076)	11.75 ^m (0.098)	-0.02 ^m (2x10 ⁻⁵)	-2.54 ^x (0.069)
OB	3.71 ^z (0.040)	-1.74 ^v (0.030)	-0.01 ^m (1x10 ⁻⁵)	13.10 ^y (0.137)	-0.03 ^m (4x10 ⁻⁵)	1.50 ^x (0.080)	11.50 ^y (0.116)	-0.02 ^m (7x10 ⁻⁵)	-2.47 ^x (0.082)

^{m,s,t,v,x,y,z} Different letters within the same column show significant difference between means of breed groups (p<0.05). ¹ Breed groups

were Toggenburg (T) or Saanen based percentage with remainder breed percentage being from any other breeds or T (OB), e.g.:S75=75%Sannen-25%OB, OB were British Alpine + Nubian + Unknown or T.

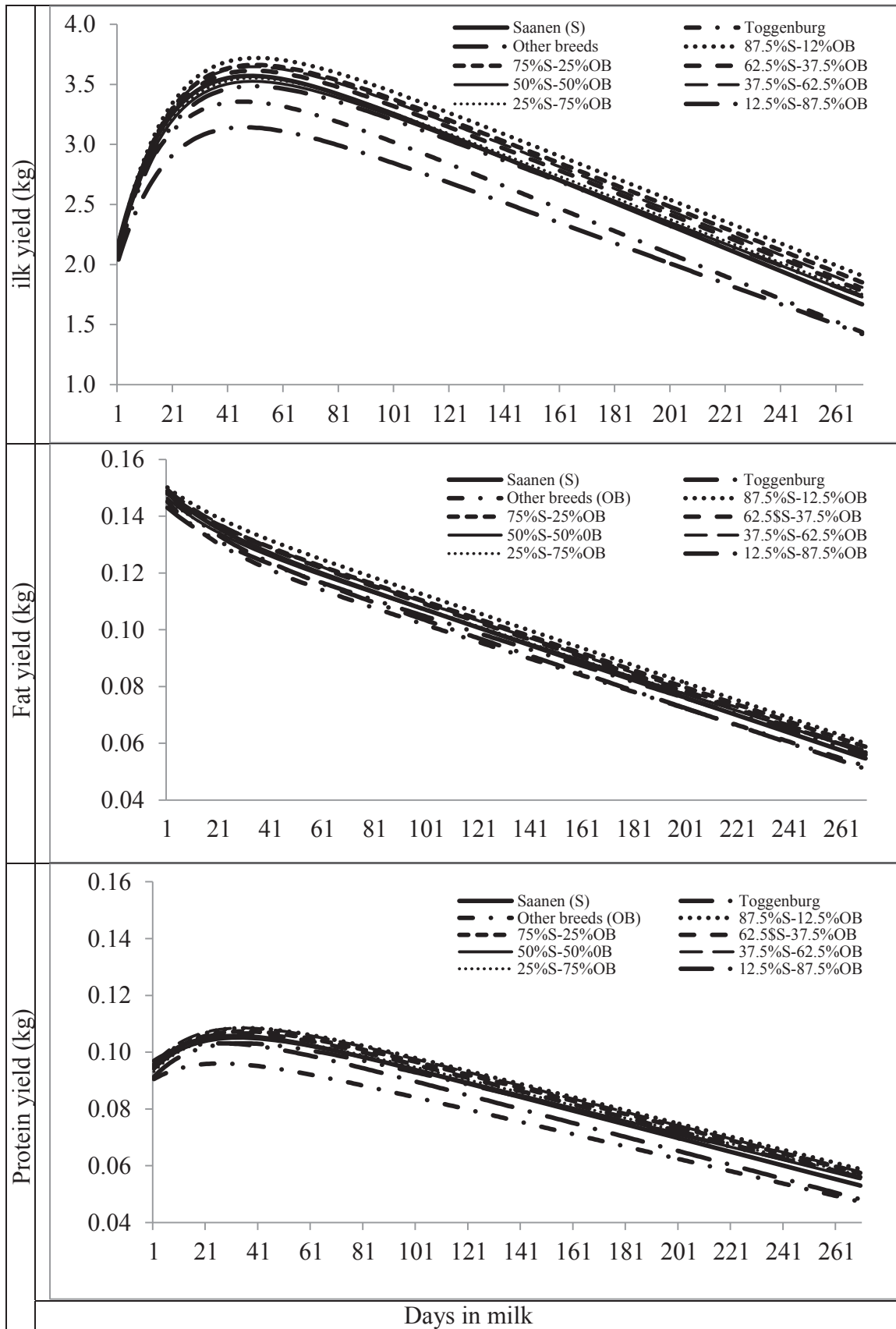

Appendix 5.3. Milk (MY), fat (FY) and protein yield (PY) curves for 10 breed groups of New Zealand dairy goats.

Appendix 5.4. Concordance correlation coefficients and significance levels for ten breed groups using the Wilmink model for milk, fat and protein yield of New Zealand dairy goats.

Breed group ¹	Trait		
	Milk yield	Fat yield	Protein yield
S100	0.89 ^m (0.001)	0.89 ^m (0.001)	0.90 ^m (0.001)
S87	0.91 ^s (0.002)	0.91 ^s (0.003)	0.97 ^s (0.003)
S75	0.88 ^t (0.004)	0.88 ^t (0.005)	0.90 ^m (0.003)
S62	0.93 ^v (0.001)	0.93 ^v (0.002)	0.94 ^t (0.001)
S50	0.92 ^x (0.001)	0.92 ^x (0.001)	0.93 ^v (0.001)
S37	0.95 ^y (0.002)	0.95 ^y (0.003)	0.95 ^x (0.003)
S25	0.94 ^z (0.001)	0.94 ^z (0.001)	0.94 ^t (0.001)
S12	0.96 ^h (0.001)	0.96 ^h (0.001)	0.97 ^s (0.004)
T	0.92 ^x (0.002)	0.92 ^x (0.002)	0.92 ^y (0.002)
OB	0.91 ^s (0.004)	0.91 ^s (0.004)	0.91 ^z (0.004)

^{m,s,t,v,x,y,z,h} Different letters within the same trait shows significant difference between breed group (p<0.05). ¹ Breed groups were Toggenburg (T) or Saanen based percentage with remainder breed percentage being from any other breeds (OB: British Alpine + Nubian + Unknown) or T.

CHAPTER 6
LACTATION CURVES FOR NEW ZEALAND DAIRY GOATS USING
RANDOM REGRESSION MODELS: LACTATION YIELDS OF MILK
FAT AND PROTEIN BY BREED GROUP AND LACTATION NUMBER

ABSTRACT

The aim of this study was to estimate lactation yields of milk, fat and protein for different breed groups and lactation numbers of New Zealand dairy goats at actual lactation length, predicted at actual lactation length and predicted at 270 days in milk. A database was constructed using 154,984 test-day records (TDR) of 43,311 lactations from 35 dairy goat farms supplying the New Zealand Dairy Goat Cooperative Ltd, from the Waikato of New Zealand. Data were sorted into ten breed groups: Toggenburg (T), Other breed groups (OB=Alpine, Nubian and unknown breed genetic composition) and eight Saanen based breed groups (Saanen (S100), 7/8Saanen-1/8O (S87) (O=percentage of OB or Toggenburg), 6/8S-2/8O (S75), 5/8S-3/8O (S62), 4/8S-4/8O (S50), 3/8S-5/8O (S37), 2/8S-6/8O (S25), and 1/8S-7/8O (S12)). There were five lactation number groups. Lactation yields at actual lactation yield, predicted at actual lactation and predicted at 270 days in milk were estimated from daily yields, which were predicted using a random regression model fitting the Wilmink function to model the lactation curve. Significant differences were found for all traits between the Saanen breed groups and Toggenburg ($p < 0.05$). The S75 group had significantly higher lactation yields of milk, fat and protein than the other breed groups ($p < 0.05$). The S100 produced significantly less milk yield ($p < 0.05$), but the same predicted fat and protein yield than S25 ($p > 0.05$). S100 and S50 performed similarly ($p > 0.05$). The T group had the lowest yields for the three traits. Lactation yields for all traits per lactation number differed significantly among all lactations ($p < 0.05$) except for the actual values among lactations 3, 4 and 5 which were similar ($p > 0.05$). Lactation 1 and 3 performed lowest and highest, respectively. Significant differences between crossbred and purebred groups agreed with previous findings on heterosis effects for milk traits. Further investigation on the estimation of heterosis effects for specific breed groups are needed to define structured crossbreeding systems.

Keywords: Dairy goats, random regression models, Saanen, Wilmink, breed groups, milk traits.

INTRODUCTION

Goat milk is consumed worldwide. It is vitally important in developing countries, providing basic nutrition and sustenance to the majority of the population in rural areas.

Dairy goats can be useful in making good use of locally available fodder (Morand-Fehr 1991) and they adapt well to most agro-ecological systems (Devendra & Haenlein 2002; Devendra 2013). In industrialised countries goat milk and its products, including cheese and yogurt, have a good reputation due to their gastronomic or dietary quality. They are also used in gourmet foods or to support people who need alternative dairy products due to medicinal afflictions, such as allergies and gastrointestinal disorders (Park & Haenlein 2010). The general composition characteristics of goat milk and factors affecting milk yield per doe have been reviewed by several authors (Gall 1981; Gipson & Grossman 1990; Solaiman 2010). The production and quality of goat's milk varies with body size, diet, breed, parity, health status, season, stage of lactation, feeding and management conditions authors (Gall 1981; Gipson & Grossman 1990; Solaiman 2010).

Knowledge of the genetic variation and economic importance of milk-solid traits in goat milk are key points to support an effective genetic improvement programme for dairy goats (Ricordeau 1981). The dairy goat industry is mostly concerned with the fat and protein concentrations in the milk, both of which, plus lactose, are about 92-94% of the total milk-solids (Park & Haenlein 2010; Solis-Ramirez et al. 2011). The making of the different dairy products, such as milk powder, cheese, yogurt or ice cream, is based on the fat, protein and lactose yields, thus the industry mainly focuses on these components. Furthermore, health of the herd is a big concern for the dairy goat farmer since expenditure increases in an unhealthy herd, for example monitoring somatic cell count is relevant to prevent mastitis in dairy animals. In this way, productive and functional traits need to be addressed when organising a comprehensive genetic improvement programme to increase profitability in the dairy goat farming enterprise. Accurate measurements and appropriate dairy goat management practices can help to increase production and profits for dairy goat farms, since accurate estimation of lactation yields and shape of the lactation curve using RRM can enhance the genetic evaluation.

Chapters 4 and 5 described the modelling of the lactation curves for the base population, for breed groups and lactation number. Important differences among model parameters for some breed groups and among all lactations were reported in these chapters and the Wilmink (WK) model was selected as the best model after using AIC as fit statistic. The objective of this study was to estimate the production levels for milk, fat and protein

using WK model in the total dairy goat population, by breed group and by lactation number at actual lactation length, at predicted lactation length and at 270 days in milk.

MATERIALS AND METHODS

Data and farming system

A database was constructed using 154,984 TDR of 18,715 milking does and 43,311 lactations from 35 dairy goat farms supplying the Dairy Goat Cooperative, Ltd (DGC) from the region of Waikato, New Zealand (Solis-Ramirez et al. 2011). The general features of the farming system were described in a previous chapter 4 and in a published paper (Solis-Ramirez et al. 2011). Briefly, the herd structure consisted of 18.6% 0-1 year olds, 14.5% 1-2 year olds, 12.9% 2-3 year olds, 10.8% 3-4 year olds, 8.8% 4-5 year olds, 4.9% 5-6 year olds, 2.7% 6-7 year olds, 1.6% 7-8 year olds, 1.2% 8-9 year olds, 1.1 % 9-10 year olds, and 0.9% 10+ year olds. The breed composition of this population was 97.5% Saanen, or Saanen by Toggenburg crosses and the remaining 2.5% were mainly British Alpine, Nubian and Saanen by British Alpine and Saanen by Nubian crosses. Milking goats kid once a year and were milked twice a day for a range of 13 to 305 days in milk and an average lactation length of 227 days. Milk traits were estimated to a standard lactation length of 270 days. A highly seasonal kidding period occurred between June and October.

Breed and lactation groups

Does were grouped into Toggenburg (T), Other breed groups (OB=Alpine, Nubian and unknown breed genetic composition) and 8 Saanen-based breed groups as: Saanen (S100), 7/8Saanen-1/8OB (S87) (OB=percentage of British Alpine, Nubian, unknown breed or T), 6/8S-2/8OB (S75), 5/8S-3/8OB (S62), 4/8S-4/8OB (S50), 3/8S-5/8OB (S37), 2/8S-6/8OB (S25), and 1/8S-7/8OB (S12). Fractions were represented as percentage values.

Lactations were grouped into five lactations. The number of does per lactation after five was very small; therefore, these were combined into lactation number 5. Does that started their lactations during January and May, and between October and December were included in June and October, respectively. Therefore, the kidding season was grouped along five months from June to October.

Although ten breed groups were considered, a subset of five of the ten breed groups and all five lactations was chosen to be presented and discussed in text. The breed groups to discuss were chosen to represent pure breeds (S100 and T) and the more numerous breed groups (S100, S75, S50 and S25).

Milk, fat and protein yield

The least square means (LSM) for actual lactation length, predicted lactation length and predicted to 270 days in milk data for milk, fat and protein were estimated for the general population, by breed group and by lactation number using the Wilmink model. The milk, fat and protein estimations at the three levels were identified as:

Estimation	Abreviation for type of estimation in trait		
	Milk	Fat	Protein
At actual lactation length	MY _{act}	FY _{act}	PY _{act}
Predicted at actual lactation length	MY _{ll}	FY _{ll}	PY _{ll}
Predicted at 270 days in milk	MY ₂₇₀	FY ₂₇₀	PY ₂₇₀

Modelling of lactation curves

Random regression models (RRM)

The individual TDR for milk, fat and protein yields were analysed using RRM to calculate the polynomial regression coefficients for lactation using the ASReml 3.0 software package (Gilmour et al. 2009) as described in Chapter 4.

Wilmink model and fitness of the model

A description of the WK model was presented in Chapter 4 and 5. Daily yields of milk, fat and protein were estimated using the model parameters for each milking doe. Model parameters were adjusted for non-genetic and breed effects and LSM for the population, per breed group and per lactation number were estimated and presented in previous Chapters 4 and 5. Level of model fit in the population, by breed group and lactation number was described in Chapters 4 and 5. However CCC and standard errors were calculated for all traits.

Concordance correlation coefficient

Concordance correlation coefficients and standard errors for each breed group and lactation number were estimated between each pair of type of trait estimations, using Lin (1989) and Franklin et al. (2014) equations previously described in Chapter 5.

Statistical analysis

A linear model was used to estimate the LSM for actual and predicted yields using the MIXED procedure of SAS Version 9.3 (SAS, 2012). The statistical model was:

$$Y_{ijkl} = \mu + \delta_i + \rho_j + \tau_k + h_l + \varepsilon_{ijkl}$$

where:

Y_{ijkl} = an observation of a milk trait yield) for a milking doe of breed group i ($i=1, \dots, 10$), lactation number j ($j=1, \dots, 5$), year k ($k=1, \dots, 20$) and herd l ($l=1, \dots, 35$);

μ = population mean;

δ_i = fixed effect of the i -breed group ($i=1, 2, \dots, 10$);

ρ_j = fixed effect of the j -lactation number ($j=1, 2, \dots, 5$);

τ_k = fixed effect of the k -year ($k=1989, \dots, 2009$);

h_l = effect of the l -herd ($l=1, \dots, 35$); and

ε_{ijkl} = random error inherent to each Y_{ijkl} observation.

Random errors (ε_{ijkl}) were assumed to be independent and normally distributed with $\mu = 0$ and variance = σ_e^2 .

RESULTS

Milk, fat and protein production in the total population

The LSM for milk, fat and protein yield calculated at actual lactation length, predicted at lactation length and at 270 days in milk using the WK model were 628.26(6.70), 624.11(6.41) and 748.93(6.17), 21.45(0.24), 22.23(0.24) and 26.28(0.28) and

18.08(0.19), 18.89(0.19) and 22.68(0.17) for MY_{act} , PMY_{ll} , PMY_{270} , FY_{act} , PFY_{ll} , PFY_{270} , PY_{act} , PPY_{ll} and PPY_{270} , respectively.

Milk, fat and protein production per breed group

The LSM and significance levels for the actual and predicted milk traits for the five breed groups using the WK model are shown in Table 6.1. The LSM for all breed groups are presented in Appendix 6.1. Consistent and significant differences for all traits were found among S100, S75 and T breed groups ($p < 0.05$). S100, S50 and S25 were similar for fat and protein ($p > 0.05$), while S25 significantly differed in milk yield from S100 and S50 ($p < 0.05$). Toggenburg does yielded significantly lower milk, fat and protein than any other Saanen-based group ($p < 0.05$).

Milk, fat and protein production per lactation number

The LSM and significance levels ($p < 0.05$) for milk, fat and protein yield per lactation number are shown in Table 6.1. Important differences among all lactations were found ($p < 0.05$). Lactations 3, 4 and 5 were similar for MY_{act} , FY_{act} and PY_{act} only. Lowest lactation yield was for Lactation 1. Lactation yields increased to parity 3 followed by a decline to parity 5 for predicted traits ($p < 0.05$).

Concordance correlation coefficient

Estimated CCC and their standard errors for five breed groups and lactations are presented in Table 6.2. The values for the ten breed groups are presented in Appendix 6.2. The values estimated for CCC ranged from 0.71 to 0.95 in the breed groups, while for lactation number ranged from 0.59 to 0.96. Highest CCC were estimated between MY_{act} - MY_{ll} , FY_{act} - FY_{ll} and PY_{act} - PY_{ll} followed by estimations between predicted traits at predicted lactation length and predicted at 270 days in milk and then between estimations between actual lactation length and prediction at 270 days in milk.

Table 6.1. Least square means (standard errors) and significance levels for milk, fat and protein yield at actual lactation length, predicted at actual lactation length and predicted to 270 days in milk (MY_{act} , PMY_{II} and PPY_{270} ; FY_{act} , PFY_{II} and PFY_{270} , and PY_{act} , PPY_{II} and PPY_{270} , respectively) for five breed groups and lactations of New Zealand dairy goats.

Trait	Breed group ² or lactation				
	S100	S75	S50	S25	T
MY_{act}	623.17 ^m (6.703)	659.24 ^x (6.945)	619.93 ^m (6.814)	633.41 ^y (7.297)	565.68 ^s (7.626)
PMY_{II}	619.63 ^m (6.334)	652.21 ^y (6.564)	618.29 ^m (6.439)	626.81 ^w (6.896)	573.88 ^v (7.207)
PPY_{270}	751.77 ^m (6.086)	785.17 ^y (6.307)	750.78 ^m (6.188)	757.41 ^w (6.626)	692.92 ^v (6.924)
FY_{act}	21.05 ^m (0.239)	22.01 ^x (0.248)	21.18 ^y (0.243)	21.49 ^z (0.260)	20.13 ^s (0.272)
PFY_{II}	21.90 ^m (0.224)	22.73 ^y (0.232)	21.97 ^m (0.227)	22.10 ^m (0.244)	21.24 ^v (0.255)
PFY_{270}	26.19 ^m (0.215)	26.98 ^y (0.222)	26.27 ^m (0.218)	26.32 ^m (0.234)	25.26 ^v (0.244)
PY_{act}	18.44 ^m (0.193)	19.27 ^x (0.200)	18.49 ^m (0.196)	18.87 ^y (0.211)	17.40 ^s (0.220)
PPY_{II}	18.64 ^m (0.182)	19.443 ^y (0.189)	18.74 ^m (0.186)	18.97 ^m (0.199)	17.88 ^v (0.208)
PPY_{270}	22.61 ^m (0.172)	23.417 ^y (0.178)	22.77 ^m (0.175)	22.98 ^m (0.188)	21.56 ^v (0.196)
	1	2	3	4	5 ⁺
MY_{act}	430.37 ^m (6.760)	635.66 ^v (6.840)	688.74 ^w (6.913)	693.81 ^w (7.014)	692.75 ^w (7.076)
PMY_{II}	479.30 ^m (6.388)	664.26 ^v (6.464)	693.77 ^w (6.533)	674.77 ^x (6.628)	627.44 ^y (6.687)
PMY_{270}	608.87 ^m (6.138)	776.95 ^v (6.211)	821.71 ^w (6.278)	796.72 ^x (6.369)	749.41 ^y (6.425)
FY_{act}	14.85 ^m (0.241)	21.94 ^v (0.244)	23.53 ^w (0.246)	23.57 ^w (0.250)	23.36 ^w (0.252)
PFY_{II}	17.18 ^m (0.226)	23.07 ^v (0.228)	24.69 ^w (0.231)	23.98 ^x (0.234)	22.21 ^y (0.236)
PFY_{270}	21.45 ^m (0.217)	27.01 ^v (0.219)	28.84 ^w (0.221)	27.92 ^x (0.225)	26.15 ^y (0.227)
PY_{act}	12.88 ^m (0.195)	18.88 ^v (0.197)	20.55 ^w (0.199)	20.58 ^w (0.202)	20.52 ^w (0.204)
PPY_{II}	14.52 ^m (0.184)	19.51 ^v (0.187)	21.06 ^w (0.188)	20.36 ^x (0.191)	18.97 ^y (0.193)
PPY_{270}	18.48 ^m (0.174)	23.23 ^v (0.176)	24.94 ^w (0.178)	24.05 ^x (0.180)	22.70 ^y (0.182)

^{m,s,x,y,w}Different letters within the same row show significant differences between means

of breed groups ($p < 0.05$). ²Breed groups were Toggenburg (T) or Saanen based percentage with the remaining breed percentage being from any other breeds (OB) or T, e.g. S87=Saanen 87.5%-OB 12.5%. OB was: British Alpine + Nubian + Unknown or T.

⁺Number of does with more than 5 lactations was added up to this lactation number.

Table 6.2. Concordance correlation coefficients (and standard errors) for five breed groups and five lactations for actual lactation length, predicted to lactation length and predicted to 270 days in milk for milk, fat and protein traits in New Zealand dairy goats.

Breed Group ¹	Milk yield				Fat yield				Protein yield			
	MY _{act} ⁻ MY _{II}	MY _{act} ⁻ MY ₂₇₀	MY _{II} ⁻ MY ₂₇₀	FY _{act} ⁻ FY _{II}	FY _{act} ⁻ FY ₂₇₀	FY _{II} ⁻ FY ₂₇₀	PY _{act} ⁻ PY _{II}	PY _{act} ⁻ PY ₂₇₀	PY _{II} ⁻ PY ₂₇₀	PY _{act} ⁻ PY ₂₇₀	PY _{II} ⁻ PY ₂₇₀	PY _{act} ⁻ PY ₂₇₀
S100	0.90 ^m (0.001)	0.74 ^m (0.001)	0.84 ^m (0.001)	0.90 ^m (0.001)	0.74 ^m (0.001)	0.86 ^m (0.001)	0.91 ^m (0.001)	0.73 ^m (0.001)	0.83 ^m (0.001)	0.83 ^m (0.001)	0.83 ^m (0.001)	0.83 ^m (0.001)
S75	0.89 ^v (0.002)	0.74 ^m (0.003)	0.84 ^m (0.002)	0.89 ^v (0.002)	0.72 ^v (0.003)	0.85 ^v (0.002)	0.89 ^v (0.002)	0.71 ^v (0.004)	0.83 ^m (0.002)	0.83 ^m (0.002)	0.83 ^m (0.002)	0.83 ^m (0.002)
S50	0.93 ^s (0.001)	0.80 ^t (0.002)	0.87 ^t (0.001)	0.93 ^t (0.001)	0.80 ^t (0.002)	0.89 ^t (0.001)	0.93 ^s (0.001)	0.79 ^t (0.002)	0.87 ^t (0.001)	0.87 ^t (0.001)	0.87 ^t (0.001)	0.87 ^t (0.001)
S25	0.95 ^t (0.001)	0.82 ^x (0.003)	0.86 ^x (0.002)	0.95 ^s (0.001)	0.82 ^s (0.003)	0.89 ^t (0.002)	0.95 ^t (0.001)	0.80 ^x (0.004)	0.85 ^v (0.002)	0.85 ^v (0.002)	0.85 ^v (0.002)	0.85 ^v (0.002)
T	0.93 ^s (0.002)	0.78 ^s (0.005)	0.85 ^s (0.003)	0.95 ^s (0.001)	0.82 ^s (0.004)	0.81 ^s (0.004)	0.93 ^s (0.002)	0.76 ^s (0.005)	0.83 ^m (0.004)	0.83 ^m (0.004)	0.83 ^m (0.004)	0.83 ^m (0.004)
Lact. Num.												
1	0.88 ^m (0.001)	0.62 ^m (0.002)	0.87 ^m (0.001)	0.88 ^m (0.001)	0.64 ^m (0.002)	0.82 ^m (0.001)	0.88 ^m (0.001)	0.59 ^m (0.002)	0.77 ^m (0.001)	0.77 ^m (0.001)	0.77 ^m (0.001)	0.77 ^m (0.001)
2	0.94 ^s (0.001)	0.80 ^s (0.002)	0.90 ^s (0.001)	0.94 ^s (0.001)	0.79 ^s (0.002)	0.87 ^s (0.001)	0.94 ^s (0.001)	0.78 ^s (0.002)	0.84 ^s (0.001)	0.84 ^s (0.001)	0.84 ^s (0.001)	0.84 ^s (0.001)
3	0.95 ^t (0.001)	0.84 ^t (0.002)	0.90 ^s (0.001)	0.95 ^t (0.001)	0.82 ^t (0.002)	0.88 ^t (0.001)	0.96 ^t (0.001)	0.82 ^t (0.002)	0.86 ^t (0.001)	0.86 ^t (0.001)	0.86 ^t (0.001)	0.86 ^t (0.001)
4	0.90 ^v (0.001)	0.81 ^v (0.003)	0.91 ^t (0.001)	0.91 ^v (0.001)	0.80 ^v (0.003)	0.89 ^v (0.001)	0.90 ^v (0.001)	0.79 ^v (0.003)	0.87 ^v (0.002)	0.87 ^v (0.002)	0.87 ^v (0.002)	0.87 ^v (0.002)
5 ⁺	0.74 ^x (0.003)	0.66 ^x (0.004)	0.85 ^v (0.002)	0.75 ^x (0.003)	0.65 ^x (0.005)	0.88 ^t (0.002)	0.75 ^x (0.003)	0.64 ^x (0.005)	0.85 ^x (0.002)	0.85 ^x (0.002)	0.85 ^x (0.002)	0.85 ^x (0.002)

^{m,s,t,v,x}Different letters within the same column show significant differences between breed groups or lactations (p<0.05). Abbreviations were

defined previously. ¹Breed groups were Toggenburg (T) or Saanen based percentage with the remaining breed percentage being from any other breeds (OB) or T, e.g. S87=Saanen 87.5%-OB 12.5%. OB was: British Alpine + Nubian + Unknown or T. ⁺Number of does with more than 5 lactations was added up to this lactation number.

DISCUSSION

Lactation yield of milk, fat and protein in the population

Least squares means for lactation yields of milk, fat and protein at actual and predicted days in milk in this study were similar to average production levels of milking does under indoor conditions from Cuba (González-Peña et al. 2012; Ribas & Gutierrez 2001), Mexico (Montaldo et al. 2010; Torres-Vazquez et al. 2010b; Torres-Vázquez et al. 2009), Spain (Fernández et al. 2002) and USA (García-Peniche et al. 2012). However, the daily predicted yields were higher than previous values reported by Morris et al. (2006) from a New Zealand herd, this could be due to the size of the data base, management improvement and different selection background for milk yield in the herds.

Production per breed group

Saanen breed yielded significantly more milk than the Toggenburg breed which agrees with previous publications (Haenlein 1996; Ricordeau 1981). S75 and S25 yielded more milk than S100 ($P < 0.05$); however, only S75 was superior to S100 for fat and protein yields. It was expected that there would be higher milk trait values for S100 than for other Saanen-based (Singireddy et al. 1997) groups; however, the average performance of some breed combinations goats is equal to or higher than S100 (Table 6.1). This situation could be explained in three ways. Firstly, the existence of non-additive effects causing heterosis effects for first (Singireddy et al. 1997) and subsequent crosses, secondly the presence of Saanen genes in the unknown breed part of the crossbred goats that, in fact, increased the amount of Saanen in the crossbred groups than is actually registered, and thirdly a mix of the two previous items. The third factor could be the most likely explanation since in the OB part of the milking does, there is a possible mix up of three goat breeds (Alpine, Toggenburg, and Nubian) crossed with Saanen and the unknown breed group of animals with a very possible Saanen origin. The effect of breed group on milk traits yield has been widely discussed by several authors (Gipson & Grossman 1990; Park & Haenlein 2010; Ricordeau 1981).

Production per lactation number

Predicted and actual production values for traits studied for five lactations are shown in Table 6.1. These results indicated that the highest production level was for lactation 4 and the lowest for lactation 1; the other lactations performed between the fourth and first lactations. However, differences between lactations 3, 4 and 5 were not different for the MY_{act} , FY_{act} and PY_{act} . The increase of milk traits up to the lactation 3 is a result of high metabolism favouring the growth over the death of cells in the mammary gland during pregnancy and lactation (Dijkstra et al. 1997) and reduction of use of energy for growth; while a further decrease in production after third lactation is a result of the inverse effect in the mammary gland and body metabolism. This increase and decrease according to lactation number agrees with previously published work (Fernández et al. 2002; Gipson & Grossman 1990; Ricordeau 1981). However, in a previous paper using an old data base for the same breeds and first crosses only, Singirredy et al. (1997a) reported that the highest milk yield was in the fifth lactation, which agree with the numeric findings of this study for milk yield at actual lactation length, however the differences with lactation three and four were not significant for any of the three traits. As was pointed out in chapter 5, the difference with Singireddy et al. (1997) and this study could be due to the size of the base data and the use of more crossbred groups in this study.

CONCLUSIONS

Saanen based breed groups yielded more milk, fat and protein than Toggenburg does, while crossbred does yielded more than purebred Saanen. The highest milk, fat and protein production was for S75 (3/4Saanen-1/4Other breeds). The higher production value for crossbred milking goats agreed with previous findings on presence of heterosis, however estimation of heterosis for specific breed crosses are needed for a design of a better genetic improvement strategy.

Milking does of lactation 3 yielded the highest predicted milk, fat and protein yield, while milking does of lactation 1 yielded the lowest. There were no differences among lactations 3, 4 and 5 for actual milk, fat and protein yield traits to actual lactation length.

Using RRM and one or more TDR per lactation resulted in similar predicted values of milk yield traits to previous studies using more TDR in dairy goats.

It is recommended a rigorous set of standards to record production and parentage to reduce the number of milking does in the unknown breed group.

APPENDICES TO CHAPTER 6

Appendix 6.1. Least square means and significance levels for milk (MY), fat (FY) and protein yield (PY) and standard errors in brackets, using the Wilmlink mathematical model for 10 breed groups of New Zealand dairy goats.

Breed group ²	Milk yield						Fat yield						Protein yield	
	Actual II	Predicted to actual II	Predicted to 270d	Actual	Predicted to actual II	Predicted to 270d	Actual	Predicted to actual II	Predicted to 270d	Actual	Predicted to actual II	Predicted to 270d	Predicted to actual II	Predicted to 270d
S100	623.17 ^m (6.703)	619.63 ^m (6.334)	751.77 ^m (6.086)	21.05 ^m (0.239)	21.90 ^m (0.224)	26.19 ^m (0.215)	18.44 ^m (0.193)	18.64 ^m (0.182)	22.61 ^m (0.172)	19.91 ^v (0.210)	19.94 ^v (0.199)	23.75 ^s (0.188)	19.44 ^x (0.189)	23.42 ^s (0.178)
S87	686.83 ^v (7.266)	674.12 ^v (6.867)	800.46 ^v (6.598)	22.90 ^v (0.259)	23.47 ^v (0.243)	27.52 ^t (0.233)	19.91 ^v (0.210)	19.94 ^v (0.199)	23.75 ^s (0.188)	19.91 ^v (0.210)	19.94 ^v (0.199)	23.75 ^s (0.188)	19.44 ^x (0.189)	23.42 ^s (0.178)
S75	659.24 ^x (6.945)	652.21 ^x (6.564)	785.17 ^x (6.307)	22.01 ^x (0.248)	22.73 ^x (0.232)	26.98 ^v (0.222)	19.27 ^x (0.200)	19.44 ^x (0.189)	23.42 ^s (0.178)	19.27 ^x (0.200)	19.44 ^x (0.189)	23.42 ^s (0.178)	19.44 ^x (0.189)	23.42 ^s (0.178)
S62	661.24 ^x (7.926)	649.76 ^x (7.490)	770.30 ^y (7.197)	22.22 ^x (0.283)	22.83 ^x (0.265)	26.68 ^x (0.254)	19.47 ^x (0.229)	19.50 ^x (0.217)	23.13 ^v (0.205)	19.47 ^x (0.229)	19.50 ^x (0.217)	23.13 ^v (0.205)	19.50 ^x (0.217)	23.13 ^v (0.205)
S50	619.93 ^m (6.814)	618.29 ^m (6.439)	750.78 ^m (6.188)	21.18 ^y (0.243)	21.97 ^m (0.227)	26.27 ^m (0.218)	18.49 ^m (0.196)	18.74 ^m (0.186)	22.77 ^m (0.175)	18.49 ^m (0.196)	18.74 ^m (0.186)	22.77 ^m (0.175)	18.74 ^m (0.186)	22.77 ^m (0.175)
S37	667.24 ^x (8.297)	660.26 ^x (7.841)	778.45 ^{xy} (7.535)	22.30 ^x (0.296)	23.05 ^x (0.277)	26.84 ^x (0.266)	19.91 ^v (0.244)	20.03 ^x (0.231)	23.64 ^s (0.218)	19.91 ^v (0.244)	20.03 ^x (0.231)	23.64 ^s (0.218)	19.91 ^v (0.244)	23.64 ^s (0.218)
S25	633.41 ^y (7.297)	626.81 ^y (6.896)	757.41 ^z (6.626)	21.49 ^z (0.260)	22.10 ^m (0.244)	26.32 ^m (0.234)	18.87 ^y (0.211)	18.97 ^m (0.199)	22.98 ^v (0.188)	18.87 ^y (0.211)	18.97 ^m (0.199)	22.98 ^v (0.188)	18.87 ^y (0.211)	22.98 ^v (0.188)
S12	641.48 ^y (8.574)	634.67 ^y (8.102)	744.86 ^m (7.785)	21.62 ^{yz} (0.306)	22.24 ^m (0.286)	25.74 ^y (0.275)	19.07 ^y (0.251)	19.20 ^m (0.238)	22.58 ^m (0.224)	19.07 ^y (0.251)	19.20 ^m (0.238)	22.58 ^m (0.224)	19.07 ^y (0.251)	22.58 ^m (0.224)
T	565.68 ^s (7.626)	573.88 ^s (7.207)	692.92 ^s (6.924)	20.13 ^s (0.272)	21.24 ^s (0.255)	25.26 ^s (0.244)	17.40 ^s (0.220)	17.88 ^s (0.208)	21.56 ^s (0.196)	21.24 ^s (0.255)	25.26 ^s (0.244)	17.88 ^s (0.208)	17.88 ^s (0.208)	21.56 ^s (0.196)
OB	524.43 ^t (8.063)	531.45 ^t (7.620)	657.17 ^t (7.322)	19.60 ^t (0.287)	20.72 ^t (0.269)	24.96 ^s (0.259)	15.99 ^t (0.233)	16.47 ^t (0.221)	20.36 ^t (0.208)	15.99 ^t (0.233)	16.47 ^t (0.221)	20.36 ^t (0.208)	15.99 ^t (0.233)	20.36 ^t (0.208)

^{m,v,s,t,xy} Different letters in the same column show significant differences between means of breed groups (p<0.05). ²Breed groups were

Toggenburg (T) or Saanen based group, e.g:S75=Saanen 75%-Other breeds (OB) 25%. OB were: British Alpine + Nubian + Unknown breed or

T.

Appendix 6.2. Concordance correlation coefficients (and standard errors) for ten breed groups for actual lactation length, predicted to lactation length and predicted to 270 days in milk for milk, fat and protein traits in New Zealand dairy goats.

Breed Group ¹	Milk yield			Fat yield			Protein yield		
	MY _{act} ⁻ MY _{II}	MY _{act} ⁻ MY ₂₇₀	MY _{II} ⁻ MY ₂₇₀	FY _{act} ⁻ FY _{II}	FY _{act} ⁻ FY ₂₇₀	FY _{II} ⁻ FY ₂₇₀	PY _{act} ⁻ PY _{II}	PY _{act} ⁻ PY ₂₇₀	PY _{II} ⁻ PY ₂₇₀
S100	0.90 ^m (0.001)	0.74 ^m (0.001)	0.84 ^m (0.001)	0.90 ^m (0.001)	0.74 ^m (0.001)	0.86 ^m (0.001)	0.91 ^m (0.001)	0.73 ^m (0.001)	0.83 ^m (0.001)
S87	0.92 ^t (0.002)	0.81 ^v (0.004)	0.88 ^x (0.002)	0.92 ^v (0.002)	0.79 ^v (0.004)	0.88 ^v (0.002)	0.92 ^v (0.002)	0.78 ^v (0.004)	0.87 ^t (0.002)
S75	0.89 ^v (0.002)	0.74 ^m (0.003)	0.84 ^m (0.002)	0.89 ^x (0.002)	0.72 ^x (0.003)	0.85 ^x (0.002)	0.89 ^x (0.002)	0.71 ^x (0.004)	0.83 ^m (0.002)
S62	0.94 ^x (0.002)	0.82 ^x (0.005)	0.86 ^y (0.003)	0.94 ^y (0.002)	0.80 ^y (0.005)	0.87 ^y (0.003)	0.94 ^y (0.002)	0.79 ^y (0.006)	0.85 ^y (0.004)
S50	0.93 ^s (0.001)	0.80 ^y (0.002)	0.87 ^z (0.001)	0.93 ^z (0.001)	0.80 ^y (0.002)	0.89 ^z (0.001)	0.93 ^s (0.001)	0.79 ^y (0.002)	0.87 ^t (0.001)
S37	0.96 ^y (0.002)	0.86 ^z (0.005)	0.89 ^h (0.003)	0.96 ^h (0.002)	0.85 ^z (0.005)	0.90 ^h (0.003)	0.96 ^z (0.002)	0.83 ^z (0.006)	0.87 ^t (0.004)
S25	0.95 ^z (0.001)	0.82 ^x (0.003)	0.86 ^y (0.002)	0.95 ^s (0.001)	0.82 ^s (0.003)	0.89 ^z (0.002)	0.95 ^h (0.001)	0.80 ^h (0.004)	0.85 ^v (0.003)
S12	0.97 ^h (0.001)	0.90 ^h (0.004)	0.91 ^w (0.003)	0.97 ^w (0.001)	0.89 ^h (0.004)	0.92 ^w (0.003)	0.98 ^w (0.001)	0.89 ^w (0.004)	0.90 ^x (0.003)
T	0.93 ^s (0.002)	0.78 ^s (0.005)	0.85 ^s (0.003)	0.95 ^s (0.001)	0.82 ^s (0.004)	0.81 ^s (0.004)	0.93 ^s (0.002)	0.76 ^s (0.005)	0.83 ^m (0.004)
OB	0.92 ^t (0.003)	0.85 ^t (0.005)	0.93 ^y (0.002)	0.91 ^t (0.003)	0.83 ^t (0.005)	0.93 ^t (0.002)	0.91 ^t (0.003)	0.82 ^t (0.006)	0.91 ^s (0.003)

^{m,v,s,t,x,y,z} Different letters in the same column show significant differences between means of breed groups (p<0.05). ²Breed groups were

Toggenburg (T) or Saanen based group, e.g:S75=Saanen 75%-Other breeds (OB) 25%. OB were: British Alpine + Nubian + Unknown breed or T.

CHAPTER 7
A BIO-ECONOMIC FARM MODEL FOR THE ESTIMATION OF
ECONOMIC VALUES

Partially published: Solis-Ramirez, J., Lopez-Villalobos, N. & Blair, H.T. 2012.
Economic values for New Zealand dairy goats. Proceedings of the New Zealand
Society of Animal Production. 72:166-168

ABSTRACT

A deterministic bio-economic farm model was developed to estimate economic values (EVs) for important production and functional traits affecting profitability and to define a breeding objective for New Zealand dairy goats. The Saanen-type dairy goats used in this study were kept indoors. All farms supplied milk to the New Zealand Dairy Goat Cooperative Ltd, (DGC), which produces milk powder for export. The payment system is based on the total amount of milk-solids (MS: fat+protein+lactose+minerals). Herd structure, costs, revenue, metabolisable energy requirements for maintenance and activity, pregnancy, lactation (milk yield, MY; fat yield, FY; protein yield, PY and lactose yield, LY) and growing of replacements and value of feed were included in the farm model. Four payment systems were investigated: total MS (Current scenario); payment ratio of 1:2 for fat (F) and protein (P), respectively (Scenario 1); payment ratio of 2:1 for F and P, respectively (Scenario 2); and MY only (Scenario 3). A value of NZ\$13.00 per kilogram MS was assumed to calculate revenue per unit of milk component. A penalty of \$0.04 per litre of milk was applied in Scenarios 1 and 2. Assumed concentration values of 3.7%, 3.2%, 4.4% and 0.7% for F, P, L and minerals, respectively, were used to estimate price per kg of F and P in the last three scenarios. In the Current scenario the economic values (EVs) for F, P, lactose (L) and volume (V) were \$11.64, \$12.27, \$12.39 and -0.10, respectively. For Scenarios 1 and 2, the EVs for FY were \$14.49 and \$28.93, and for PY were \$31.08 and \$14.36, respectively. The EV for MY was -\$0.14 both in Scenarios 1 and 2. When payment was based on MY (Scenario 3), the EV for MY was NZ\$1.43, but the EVs for all other traits were negative. The EV for liveweight, longevity and somatic cell score were -\$2.16, \$0.04 and -\$8.22, respectively. The estimated EVs will assist the New Zealand dairy goat industry to define breeding objectives for optimising genetic gain across a range of traits impacting on farm profit.

Keywords: dairy goats, economic values, milk-solids, breeding objective, farm model, genetic improvement programme.

INTRODUCTION

Goat milk is one of the most consumed animal products in the world. The world total goat population of about 880 million produce about 16 million tonnes of goat milk (FAO 2012). About 86% of the goat population is in developing countries where most

herds lack milk records and, therefore, the world figures for the production of goat milk could be underestimated. In most countries, goats have an important ecological, cultural, nutritional and economical role in society, which strongly justifies the implementation of genetic improvement programmes.

A comprehensive genetic improvement programme starts with the definition of the breeding goal for the production system (Harris et al. 1984). The breeding goal indicates the direction of an animal genetic improvement programme. Given the diversity of goat production systems and cultures across regions or countries different breeding goals and breeding objectives are likely to be required according to the local conditions and resources. This would encourage and increase goat production primarily using locally adapted breeds, which benefit the conservation of genetic bio-diversity (Ligda et al. 2000). For New Zealand dairy goats, the breeding goal can be defined in terms of profit per milking doe, profit per hectare or profit per kilogram of dry-matter intake. Once the breeding goal is defined a breeding objective is formulated as the combination of breeding and economic values of important traits affecting the breeding goal (Charfeddine 2000; Grasser et al. 2006; Groen 2000; Harris et al. 1984; Lopez-Villalobos & Garrick 2005; Newman et al. 1992; Ponzoni 1986). Information from the farming system and individual goat data are important inputs into the development of a farm model to enable the calculation of economic values and to accurately describe the breeding objective and the construction of a selection index (Hazel 1943b; Van Vleck 1979).

Hazel (1943b) defined the economic value of a trait as the amount by which net profit per animal may be expected to increase for each unit of improvement in that trait, holding the other traits constant. Economic values are needed for each trait in the breeding objective to ensure that selection emphasis is proportional to the economic importance of each trait (Amer et al. 2001).

Economic values can be derived using either partial derivatives or through the bio-economic farm model (Krupová et al. 2008; Ponzoni 1986). The bio-economic farm model can calculate profit on a per milking doe basis before and after the increase of a unit of a trait, while keeping the other traits constant (Krupová et al. 2008; Ponzoni 1986). Breeding objectives of dairy animal breeding programmes generally include milk production (usually milk, protein and fat yield), liveweight (LW), fertility and health

traits to improve efficiency, sustainability and profitability (Coleman et al. 2010; Gibson & Wilton 1998; Spelman & Garrick 1997; Visscher et al. 1994).

Life time traits, like longevity, productive herd-life or survival rate, are also important traits to be considered in the breeding programme. Longevity (LGTY) is the length of time that individual does remain in the herd after their first kidding; LGTY identifies animals that produce for a longer period of time; and survival rate provides information about the proportion of animals that survive to each parity or for a designated period of time (Hare et al. 2006). The impact of longer herd-life on profitability is mainly through lower replacement costs, more does producing at mature age levels and more milk production per unit of time; as a consequence culling losses and health costs will be reduced (Gill & Allaire 1976; Hare et al. 2006; Stott 1994; Van Arendonk 1991; VanRaden 2004).

Despite the linkage between somatic cell count (SCC) and mastitis in goats is less obvious than in cows, SCC in goat milk is an indicator of the quality of the milk and, more specifically of mammary gland ill-health, for example subclinical mastitis or clinical mastitis. Therefore it is an important functional trait in the definition of a breeding objective for the genetic improvement of dairy goats. Somatic cell score (SCS) is generally calculated as $SCS = \log_2 SCC/100000$ and is currently used in most countries around the world as an indicator trait to select for mastitis resistance in dairy cattle (Harris et al. 2005). The measurement of SCS is less expensive and more consistent than an assessment of clinical mastitis (Apodaca-Sarabia et al. 2009).

In New Zealand, the environmental conditions are conducive for pasture production for most of the year, and the various ruminant production systems are dominated by outdoor grazing. However, because of management advantages (for example parasite control), most dairy goats are kept indoors, being fed a mixture of grass and concentrates (Solis-Ramirez et al. 2011).

In the absence of a national genetic improvement scheme, achieving and monitoring genetic gain of dairy goat herds is difficult. Implementing a genetic improvement scheme is an important part of the development and progress of the dairy goat industry in New Zealand to meet product demand in the longer term. Previous studies on genetic parameters for New Zealand dairy goats suggest that milk volume, fat, protein and somatic cell count exhibit genetic variation and should be included in a breeding

objective (Apodaca-Sarabia et al. 2009; Morris et al. 2006; Singireddy et al. 1997). Recently, these findings were reinforced by Solis-Ramirez et al. (2012), who also added lactose and liveweight as further important production traits affecting profit.

The objective of the present study was to develop a deterministic bio-economic farm model to enable the estimation of economic values for important traits affecting profit to help with the definition of a breeding objective for New Zealand dairy goats.

MATERIALS AND METHODS

Description of the production system

Dairy goat production systems in the Waikato region of New Zealand were described by Solis-Ramirez et al. (2011). Briefly, the farms were located throughout the Waikato region and supplied milk to the Dairy Goat Cooperative of New Zealand (DGC). Animals were kept indoors, with approximately 89% of milking does being of the Saanen breed; 2% of Toggenburg breed; and 9% being Saanen crosses with Toggenburg, Alpine, Nubian and Boer. Liquid milk was used to produce milk powder for export. The average farm size was 74.6 ha, with 52.8 ha being dedicated to forage and crop production. Approximately 23.7 ha were dedicated to other farming activities, such as cattle and sheep production, forestry and bush land. Milking does were herd tested at least once every year; does were first mated at seven months of age, and a buck to doe mating ratio of 1:22 was used.

Components of the model

A deterministic bio-economic farm model was developed to estimate profit per milking doe per year and the economic values for important traits. Input components of the farm model were milk-solid production, herd structure, costs, revenue, physiological stage, value of feed and price per kilogram of each milk component. The model was constructed in such a way that components could be substituted or modified for different dairy goat production conditions. The description of components of the farm model is explained in the following sections.

Management, payment and dead and culled rate

Each calendar year began with the natural mating season in mid-January, which was completed in mid-May. Kidding began in mid-June and finished in mid-October. Lactation was initiated with kidding and continued for 270 days. Therefore, does kidding in the second half of June were milked until the beginning of the second half of March the following year. The drying-off period was from mid-March to mid-June.

The farmers were paid on a per kilogram of milk-solids basis (which includes milk fat, protein, lactose and minerals). Therefore, increasing any of the milk-solid components, changing ratios or combinations of both resulted in increased milk-solids and, thus, revenue. The price received from the DGC was NZ\$13.00 per kg of milk-solids, and the value of culled mature animals was NZ\$5.00 per doe or per buck.

The dead and culling rate (*DC*) per age group category was calculated as the difference between the number of animals in consecutive age group categories divided by the total number of animals in the herd. Prior to the first lactation, there were two age group categories; from birth to seven months of age, and from seven months of age to one year to differentiate between rearing and pregnant animals to go into the first lactation. These two age groups were combined into one average age group category from birth to one year of age. Does were milked between 1 and 10 years of age, and they were counted at the end of each year. Therefore,

$$DC_i = \sum_{i=0}^{10} \left(\frac{a_i - a_{i+1}}{N} \right) 100$$

where:

a_i = the number of animals in the age group category at year i ($i=0, 1, 2, 3, \dots, 10$);

a_{i+1} = the number of animals in the age group category of the previous year (year i plus 1); and

N = the total number of animals.

Energy and dry matter requirements

Diet was assumed to contain 18.4 MJ gross energy and 10.94 MJ/kgDM metabolisable energy (ME) per kilogram of dry matter (DM) in a mixed diet with fresh grass, grass hay and concentrates. The corresponding metabolisability of the diet at maintenance was 0.59 (q_m) (AFRC 1993).

The efficiencies of utilizing ME were calculated as defined in AFRC (1993):

Efficiency of maintenance $k_m = 0.35q_m + 0.503$

Efficiency for lactation: $k_l = 0.35q_m + 0.420$

Efficiency for growth of replacements..... $k_f = 0.79q_m + 0.006$

Efficiency for growth of concept: $k_c = 0.133$

where, $q_m = ME/GE$, the proportion of gross energy (GE) that is available as metabolism energy (ME).

Maintenance. Metabolic energy requirements for daily maintenance and activity at a given age (ME_m) were calculated as:

$$ME_m = \frac{(0.315LW^{0.75} + 0.024LW)}{k_m}$$

where:

LW = liveweight in kg;

$0.315LW^{0.75}$ = maintenance element estimation;

$0.024LW$ = activity element estimation; and

Lactation. Metabolisable energy requirements for lactation (ME_L) were calculated according to AFRC (1993) following the prediction of daily production of MY, FY and PY using the Wilmink equation (Wilmink 1987a):

$$(y_t = a + be^{-0.05t+ct})$$

where:

a, b and c are the parameters that define the inflection points of the production curves;

t = time (day) in the MY, FY and PY production curves; and

y_t = kilograms of MY, FY or PY at day t.

Metabolisable energy requirements for lactation in the dam were calculated as:

$$ME_L(\text{MJ/day}) = \frac{\text{MY} \times E_L}{k_L}$$

where:

MY = milk yield; and

E_L = the energy value of milk, and k_L was previously defined.

The energy value of milk was calculated as:

$$E_L(\text{MJ/kg}) = 0.034(\text{FY}) + 0.0223(\text{PY}) + 0.0199(\text{LY}) - 0.108$$

where:

LY = lactose yield; and

FY, PY were defined before.

The measurement units for FY, PY and LY are g/kg.

Growth. Metabolisable energy requirements for growth (ME_g) were calculated for a growing animal from birth to mature weight at three years of age, when energy needs were for maintenance only as the animal is assumed to have stopped growing. An average growth curve was estimated for the animals from birth to mature weight according to the growth function of Brody (1945):

$$LW_t = W(1 - be^{-kt})$$

where:

LW_t = liveweight (kg) at time t (day);

W = mature weight;

b = folding point of growth (parameter calculated);

k = growth rate; and

e = natural logarithm.

According to Bett et al. (2007a), the estimation of metabolic energy for of growth was:

$$ME_g = \frac{\Delta_{LW} (4.972 + 0.3274LW_t)}{k_f}$$

where:

Δ_{LW} = the daily liveweight change (kg); and

LW_t and k_f are previously defined.

Pregnancy. The daily energy requirements for 150 days of pregnancy (ME_p) were calculated according to AFRC (1993) as:

$$ME_p(\text{MJ/day}) = \frac{E_c}{k_c}$$

E_c = the daily energy retention in the foetus, and is given as:

$$E_c(\text{MJ/day}) = 0.25LW_t(E_t \times 0.07372e^{-0.00643t})$$

where:

E_t = energy content at time t in MJ for the gravid foetus in the pregnant doe for a kid weighing 3.7 kg and 1.95 kids/kidding.

The value of E_t was calculated as:

$$\text{Log}_{10}E_t = 3.322 - 4.979e^{-0.00643t},$$

therefore

$$E_t = 10^{3.322 - 4.979e^{-0.00643t}}$$

The total daily energy requirements per animal (ME_d) accounting for the physiological stage of the animal were calculated by adding together the daily requirements for maintenance and activity, growth, pregnancy and lactation. Daily requirements were

calculated from birth to 365 days for replacement kids, and for the age group categories of milking does. All ME values from growing animals and bucks were apportioned to the milking does because they are the only animals providing revenue:

$$ME_d(\text{MJ}/\text{day}) = (1 + 0.018(\text{FL} - 1)) \times (ME_m + ME_g + ME_p + ME_L)$$

where:

FL = feeding level as a multiple of MEM

The total metabolic energy per milking doe per day (ME/MD/day) was calculated as:

$$ME_t = \sum_{i=1}^{10} (ME_d) / N_d, \text{ and per herd } (ME_h),$$

$$ME_h = ME_t \times P_i$$

where:

N_d = age (days) of the animal in the i-age group category; and

P_i = proportion of animals in the i age category.

Dry-matter intake (DMI)

The amount of DMI required per milking doe was obtained once the energy requirements given by the above sets of equations were known. The amount of metabolisable energy in the feed was assumed to be 10.94 MJME per kg of dry-matter, based on animals being offered a diet consisting of grain base concentrates for dairy goats (60%), fresh ryegrass (30%) and ryegrass hay (10%). The total KgDMI per milking doe per day (DMI) was then calculated as:

$$\text{DMI}(\text{kg}/\text{day}) = ME_t / 10.94$$

This DMI includes an allowance for growing animals and bucks.

Feed costs

Cost of feed per animal (C_f) was estimated as:

$$C_f = (\text{KgDMI})(\$/\text{kgDM}) \text{ and}$$

Cost of feed per herd (C_H) was,

$$C_H = \sum_{i=0}^{10} C_f \times P_i$$

and cost per milking doe (C_{MD}) was,

$$C_{MD} = C_H / \sum_{i=1}^{10} P_i$$

where:

KgDMI = kilograms of dry matter intake;

\$kgDM = price in New Zealand dollars per kilogram of dry matter. A price of NZ\$0.32 per kg of DM was assumed with a diet based on 30% of fresh ryegrass, 10% of ryegrass hay and 60% concentrates.

Income

The average income (I) per animal was calculated as:

$$I = A_1[(MS) \times (NZ\$MS)] + [(A) \times (NZ\$A)]$$

Then the average income per milking doe (I_{MD}) was calculated as:

$$I_{MD} = I/A_1$$

and the income per herd (I_H) was estimated as:

$$I_H = \sum_{i=1}^{10} I_{MD} \times P_i$$

where:

MS = the total kilograms of milk-solids produced per doe;

NZ\$MS = the price per kg of milk-solids;

NZ\$A = the price per culled animal;

A_1 = number of milking does; and

A = the total number of animals culled.

The herd was considered in 11 age categories for the purposes of calculating revenue and costs: one for replacement animals (from birth to 12 months of age); and 10 for milking does (1 to 10 years of age). Bucks were not considered in any age group structure, but they were accounted for in cost calculations.

The total farm costs per milking doe (C_{MD}) were calculated as the sum of all expenses divided by the number of milking does. The overheads per milking doe were calculated as the sum of expenses due to repairs and maintenance, vehicle expenses and administration divided by the number of milking does.

Profit

Profit was expressed per milking doe (the total income minus the total cost per milking doe: $P_{MD} = I_{MD} - C_{MD}$) (Ponzoni 1986; Pyle & Larson 1981):

Traits studied

Milk yield and milk-solids production traits

The total kilograms of MS for the 2009-2010 production season were provided by the Dairy Goat Cooperative, Ltd of New Zealand (DGC), and lactation curves to 270 days of lactation length for MY, FY and PY were estimated using the Wilmink model (Wilmink 1987a).

The liveweight from birth to mature weight were obtained from a dairy goat farmers survey (Solis-Ramirez et al. 2011) and are shown in Table 7.1. The DGC payment system was NZ\$13.00 per kg of MS with no discount for MY.

Longevity

The Kaplan-Meier method (KMM) (Kaplan & Meier 1958) was used to calculate longevity (LGTY), which was defined as the probability of an individual animal surviving an extra day in the milking herd. The probability of surviving one year, and the cumulative survival from 0 to 10 years of age, was calculated according to the

KMM, which allows the estimation of a population survival curve from a fraction of animals surviving each year. The survival function was expressed as:

$$CSR_t = P_t(CSR_{t-1})$$

where:

CSR_t = the cumulative survival rate at time t (year t ; $t = 0, 1, 2, \dots, 10$), and

P_t = the probability of the animal surviving to time t and was estimated as:

$$P_t = 1 - (\eta c_t / \eta a_t)$$

where:

ηc_t = number of dead or culled animals at time t ; and

ηa_t = number of alive animals at time t .

CSR_{t-1} is defined as for CSR_t , but for the previous year.

The animals in the last year ($t=10$) were considered ‘censored’ because no further information on them was recorded.

Somatic cell score (SCS)

The Dairy Goat New Zealand payment system applies a discrete penalty to the value of milk-solids, depending on somatic cell count (SCC) levels per month throughout the year. Monthly values for SCC used in the payment system were provided by the DGC and transformed to the somatic cell score (SCS) as:

$$SCS = \log_2(SCC)$$

where:

\log_2 = natural logarithm base 2.

Three SCC and SCS thresholds were organised based on monthly and penalty values provided by the DGC. The first range was for SCC from 0 to <900,000 (no penalty), the second range was from 900,000 to <1 800,000 (the first penalty threshold: NZ\$0.10/kgMS) and >1,800,000 to <3,500,000 (the second penalty threshold:

NZ\$0.50/kgMS). For threshold >3,500,000 SCC, the previous penalty was assumed to continue as a third penalty threshold. These SCS levels were used to calculate the costs and economic value associated with SCC in bulk milk per kg MS.

Payment scenarios for milk and milk-solids

Four payment system scenarios were investigated:

1. Total milk-solids (Current scenario). Currently, the DGC pay dairy goat farmers based on kg of milk-solids, regardless of the ratio of milk components per kg of milk-solids with no penalty for MY.
2. Fat and protein under 1:2 ratio for F and P (1F+2P, or Scenario 1). The ratio of 1:2 for fat and protein yield is a regular scenario found in the dairy cattle industry due to the higher value for protein in the market place.
3. Fat and protein under 2:1 ratio for F and P (2F+1P, or Scenario 2). This is the opposite scenario to Scenario 2 and a comparison between them could be helpful to show the relevance of primary payment emphasis for either fat or protein.
4. Milk volume (Scenario 3). In many countries, milk yield is the trait of primary importance because liquid milk is highly demanded for human consumption.

A payment of NZ\$13.00 per kg MS was used to calculate revenue per milk component. Milk-solids of 3.7%, 3.2%, 4.4% and 0.7% for fat, protein, lactose and minerals, respectively (Solis-Ramirez et al. 2011), were used to estimate the price per kg of fat and protein in Scenarios 1 and 2, and the price per kg of milk in Scenario 3. A \$0.04 cost per kg of milk for collecting, transporting and drying was imposed in Scenarios 1 and 2. For the Current scenario, there was no penalty for MY, while in Scenario 3, the selection criteria is MY.

Calculating economic values

Milk, milk-solids and liveweight traits

Estimation of economic values for FY, PY, LY, MY and LW was undertaken using the farm bio-economic model developed in this study. The economic value for trait i (EV_i) was calculated as:

$$EV_i = P_{MDA_i} - P_{MDB_i}$$

where:

$P_{MD_{B_i}}$ = the profit per milking doe before one unit of improvement in the trait i ,

and

FP_{A_i} = the profit per milking doe after one unit of improvement in the trait i .

Longevity

The EV for longevity (LGTY) was estimated in a similar way to milk, milk-solids and liveweight traits, adapting the population survival curve to the farm model and calculating profit before and after adding an extra day of life to the herd.

Somatic cell score

The cost was calculated according to the threshold model described by Meijering (1986) for dystocia in dairy cattle but applied to SCS by Charfeddine et al. (1997) and Sadeghi-Sefidmazgi et al. (2011) for the estimation of economic values in dairy cattle.

The cost of SCS (C_{scs}) was calculated as:

$$C_{scs} = \sum_{i=1}^n [\Phi(z_i) - \Phi(z_{i-1})] p_i$$

where:

n =number of thresholds ($i=1, 2$ and 3);

$$z_i = \frac{(\tau_i - \mu)}{\sigma}; \text{ and}$$

$$z_{i-1} = \frac{(\tau_{i-1} - \mu)}{\sigma}.$$

$\Phi(z_i)$ = the normal cumulative distribution function (probability of the variable SCS has a value less than threshold value, z_i) is expressed as:

$$\Phi(z) = \Pr(Z < z) = \int_{-\infty}^z \frac{1}{\sqrt{2\pi}} e^{-z^2/2} dz$$

τ_i = threshold that separates SCS class i from class $i+1$ ($i=1, 2, 3$);

p_i = the penalty associated with an SCS in class i ;

μ = average SCS;

σ = standard deviation SCS;

e = base of the natural logarithms base e ; and

$\pi = 3.14159365359$.

The economic value for SCS was estimated in a separate model according to threshold model proposed by Meijering (1986) for dystocia in dairy cattle, but applied to SCS by Charfeddine et al. (1997) and Sadeghi-Sefidmazgi et al. (2011). The economic value for SCS (a_{SCS}) was calculated as:

$$a_{SCS} = -\frac{1}{\sigma} \left[\sum_{i=1}^n \varphi(Z) \times (p_i - p_{i-1}) \right]$$

where:

p_i, σ = was defined before;

$\varphi(Z)$ = is the standard normal density function that shows the vertical height on the normal distribution, and can be expressed as:

$$\varphi(Z) = \frac{\partial \Phi(Z)}{\partial Z} = \frac{1}{\sqrt{2\pi}} e^{-z^2/2}$$

where:

e = natural logarithm base e ; and other terms were previously defined.

Relative economic value (REV)

For the ease of comparing economic values of each trait i (EV_i), they were expressed relative to fat yield EV (EV_{FY}) as:

$$REV_i = \frac{EV_i}{EV_{FY}}$$

Sensitivity analysis of economic values

A sensitivity analysis for the Current scenario was used to examine how the bio-economic farm model responded to different market or production system scenarios, thereby detecting possible impacts of EVs. Sensitivity was tested by applying a 15% increase/decrease (NZ\$0.0468/kg DM) in feed costs or a 15% increase/decrease in the price of milk revenue (NZ\$1.95/kg MS), keeping all other traits and parameters constant. The differences between new EVs and the EVs from the Current scenario were expressed as percentages.

RESULTS

Herd structure, dead and culling rate

The herd and milking doe age group structure is presented in Table 7.1. The 183 replacement does are those that got pregnant, and 159 of these became first-time milkers.

The average DC rate for the birth and seven months, 1 to 6 years and from 7 to 10 years age groups were 3.34%, 2.30% and 0.42%, respectively, showing a decreasing trend as animal age increased. There were no deaths registered between year 9 and 10. There was an average DC of 2.42% for MD, while it was 1.84% for the herd, which reflects a higher number of culled animals in the milking does after the first year (Table 7.1).

Bucks were selected based on pedigree performance for milk-solids on their dams. On average, seven bucks were sourced from within the herd and one was purchased (Figure 7.1). Bucks were culled after an average of three seasons of use.

Milk and milk-solids production

The parameters (a, b and c representing the intercept, the ascending and the descending phase, respectively in the Wilmink model) (Wilmink 1987a) used to estimate the lactation traits curves were 3.90, -1.7 and -0.007 for milk yield; 0.12, 0.01 and -0.0002 for fat yield; and 0.10, 0.009 and -0.0001 for protein yield, respectively. The concordance correlation coefficients between actual and predicted milk, fat and protein values using the Wilmink (1987a) equation were 0.90, 0.92 and 0.93 (Figure 7.2, Figure 7.3 and Figure 7.4).

Table 7.1. Number and percentage values of female animals in the general and milking does herd, dead and culling rate and liveweight per age group category.

Age group (years)	No. animals	Percentage		DC ²		
		Herd	MD	Herd	MD ³	LW ¹ (kg)
0	183	21.03		3.34		19.6
1	159	18.28	23.14	2.23	3.49	52.2
2	141	16.21	20.52	1.67	2.62	76.1
3	117	13.45	17.03	2.23	3.49	80.0
4	96	11.03	13.97	1.95	3.06	84.0
5	64	7.36	9.32	2.97	4.66	84.0
6	35	4.02	5.09	2.69	4.22	84.0
7	23	2.64	3.35	1.11	1.75	84.0
8	18	2.07	2.62	0.46	0.73	84.0
9	17	1.95	2.47	0.09	0.15	84.0
10	17	1.95	2.47	0.00	0.00	84.0
Average		9.10	10	1.70	2.42	74.2

¹ LW = liveweight, ²DC = dead and culling rate. ³MD = milking does.

Growth curves

The liveweight (LW) for each age group of animals was obtained from the farmers survey (Solis-Ramirez et al. 2011) and is given in Table 7.1. The animal growth curve over a period of three years using Brody's (1945) equation are presented in Figure 7.5. The parameter values used in Brody's equation were 86.5, 0.959 and 0.00254 for W (mature weight), b (folding point of growth) and k (growth rate), respectively. The accuracy of fit between the actual and predicted weights using Brody's equation was high, with a correlation coefficient of 0.99 between predicted and actual liveweight and an average LW for milking does of 80 kg.

Metabolic energy and feed intake

The average daily ME and DMI requirements per age group category are presented in Table 7.2.

The use of metabolic energy varied according to age group and, therefore, the DMI per animal to produce a kilogram of milk component also changed. The DMI ranged from 1.72 kg per day for first time milkers to approximately 2.50 kg for second and third

lactation does. There was an average DMI for all age group milking does of 2.12 kg/day.

Longevity

The survival information analysis for the dairy goat herd is presented in Table 7.3 and illustrated in Figure 7.6. The highest culling/dead rates occurred in 5 to 8-year old does (average = 33.7%), and the lowest was for does older than 8 years (2.8%). For does from 0 to 4 years old, an intermediate value between the two previous groups of 15.2% was estimated.

Somatic cell score

The SCC ranges, frequency and penalty values are presented in Table 7.4. About 81% of SCC are equal to or less than 1,800,000 (or 6.8 SCS), while 19% was between 6.8 and 8.16 SCS.

Farm revenue, cost and profit

The factors accounted for in the development of the dairy goat bio-economic farm model are described in Figure 7.7, and details of the farm expenses, overheads, revenues and profits per milking doe are shown by Solis-Ramirez et al. (2011). Number of milking does and bucks are presented in Table 7.1.

The major expense was labour (the combined values of family labour and dairy wages), which was 34.75% of the total cost, while concentrates and mineral supplements were 21.6%. Other expenses related to pasture renovation and management were 21.5%, and overheads accounted for 14.0%. About 99% of revenue came from milk-solids, with less than 1% from culled animals. Dairy goat farm revenue on a per milking doe basis is almost solely dependent on milk-solid production since goat meat has no substantial value. Annual revenue and profit per milking doe was, on average, NZ\$1,218.17 and \$358.88, respectively.

Table 7.2. Age group categories, number of milking does, milk (MY), fat (FY), protein (PY) and lactose (LY) yield, metabolisable energy (ME) and dry-matter intake (DMI) requirements per year per milking doe.

Age group (years)	No. animals	MY (kg)	FY(kg)	PY (kg)	LY (kg)	ME (MJ)	DMI (kg)
1	159	684.72	23.69	20.55	29.44	4454.5	424.2
2	141	846.18	29.17	25.29	36.39	9436.3	898.7
3	117	907.36	30.94	27.07	39.02	9504.0	905.1
4	96	877.19	29.78	26.15	37.72	9444.4	899.5
5	64	873.71	29.44	25.99	37.57	9444.4	899.5
6	35	732.40	28.10	24.83	35.79	9444.4	899.5
7	23	728.44	26.49	23.53	33.64	9444.4	899.5
8	18	723.98	24.32	21.79	31.13	9444.4	899.5
9	17	689.77	24.18	21.39	29.66	9444.4	899.5
10	17	680.08	23.94	21.10	29.31	9444.4	899.5
Average		774.38	27.01	23.77	33.97	8950.6	852.5

Table 7.3. Survival analysis in the dairy goat herd using the Kaplan-Meier (1958) method.

Year	Surviving		Not surviving		Cumulative survival (%)
	Number	%	Number	%	
0	183 ¹	83.2	37	16.8	83.2
1	159	86.9	24	13.1	72.3
2	141	88.7	18	11.3	64.1
3	117	83.0	24	17.0	53.2
4	96	82.1	21	17.9	43.6
5	64	66.7	32	33.3	29.1
6	35	54.7	29	45.3	15.9
7	23	65.7	12	34.3	10.5
8	18	78.3	5	21.7	8.2
9	17	94.4	1	5.6	7.7
10	17	1.0	17 ²	0.0	7.7

¹Out of 220 replacement kids. ²Censored data

Economic values for traits studied

The price per kg for MS, EVs and REVs for the four scenarios are shown in Table 7.5. EVs for MY were negative in the three scenarios where payment was based on milk-solids, but the EV was positive when payment was based on MY, but negative

economic values for milk-solids traits (Scenario 3). A negative EV was estimated across all scenarios for LW. The EV for LGTY was positive for all scenarios (NZ\$0.04), while the EV calculated for SCS was estimated at -NZ\$8.21.

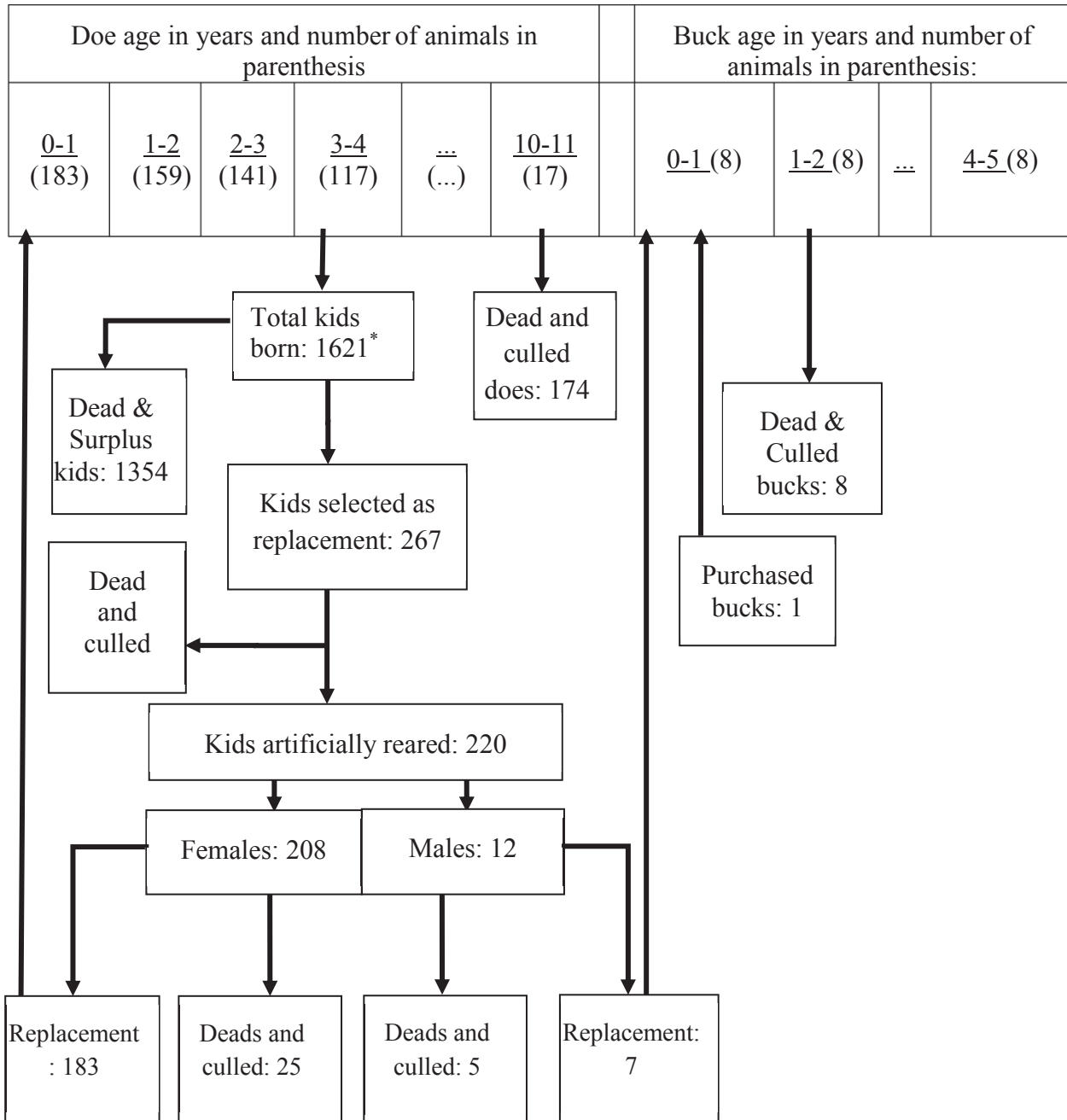

Figure 7.1. Herd dynamics and breeding in the dairy goat farm per year. The number of animals is presented in parenthesis.

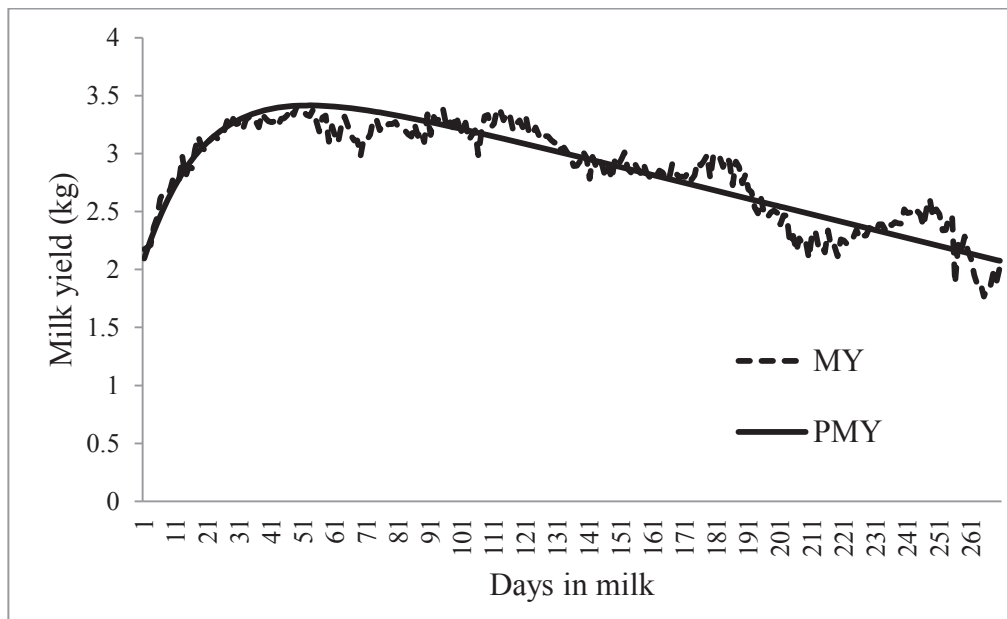

Figure 7.2. Actual (MY) and predicted (PMY) milk yield for New Zealand dairy goats.

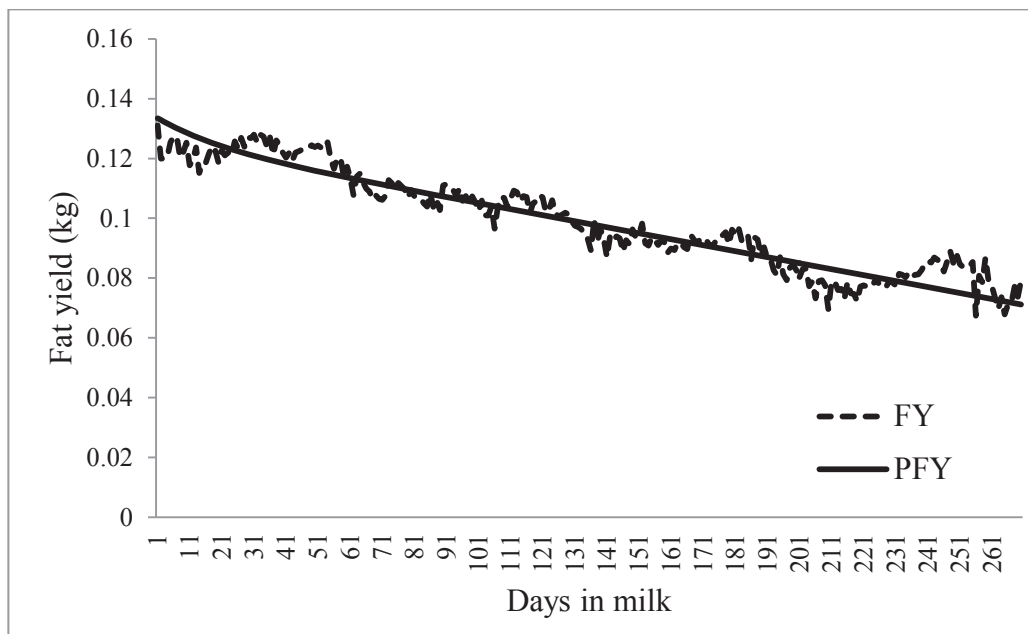

Figure 7.3. Actual (FY) and predicted (PFY) fat yield for New Zealand dairy goats.

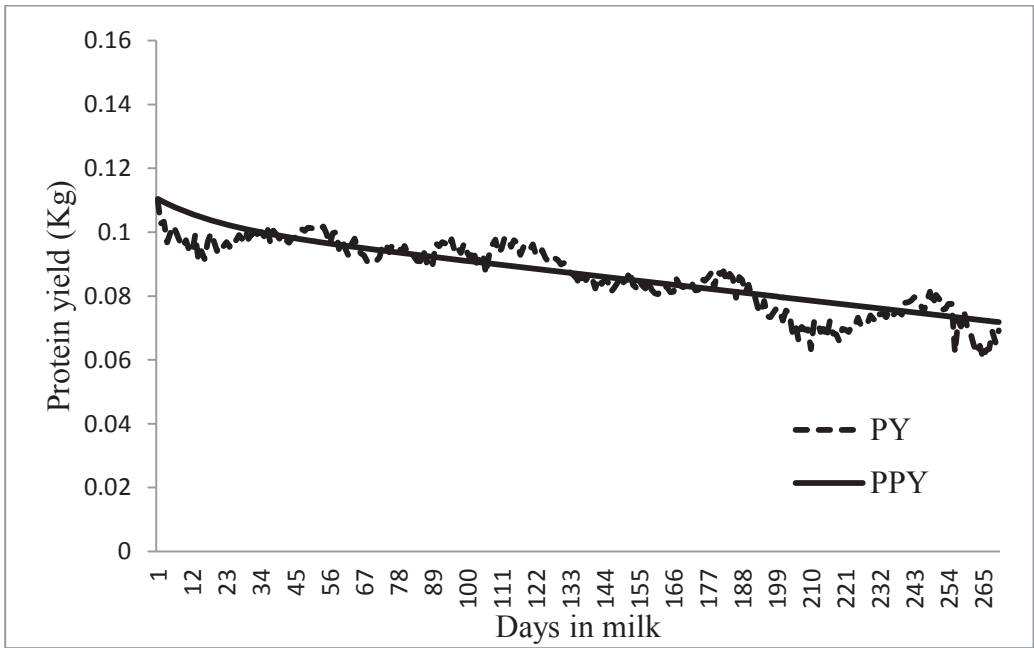

Figure 7.4. Actual (PY) and predicted (PPY) protein yield for New Zealand dairy goats.

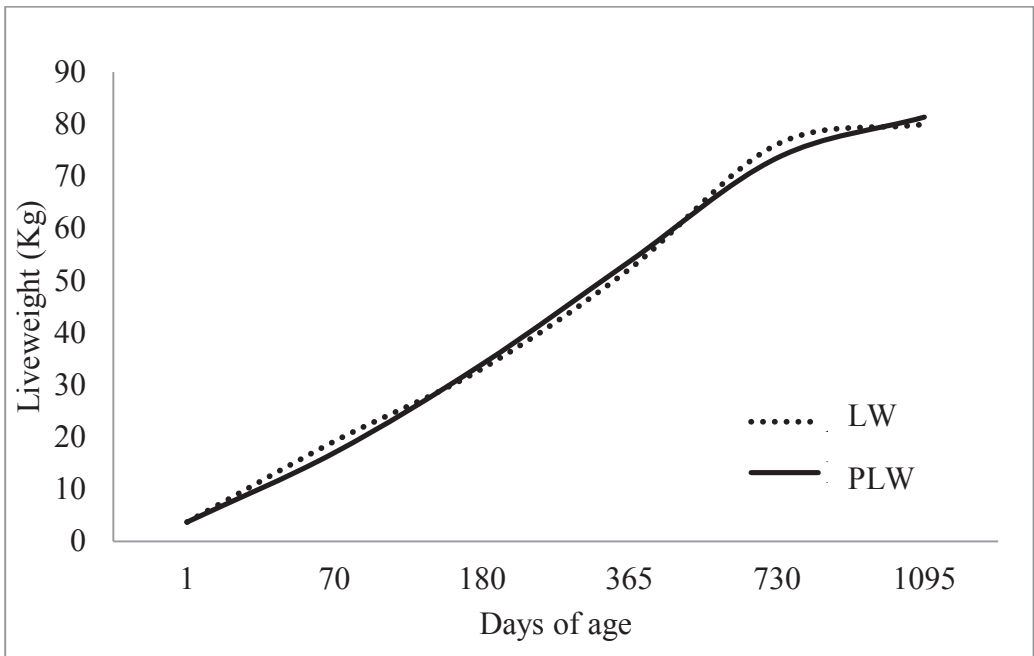

Figure 7.5. Actual (LW) and predicted (PLW) liveweight for New Zealand dairy goats.

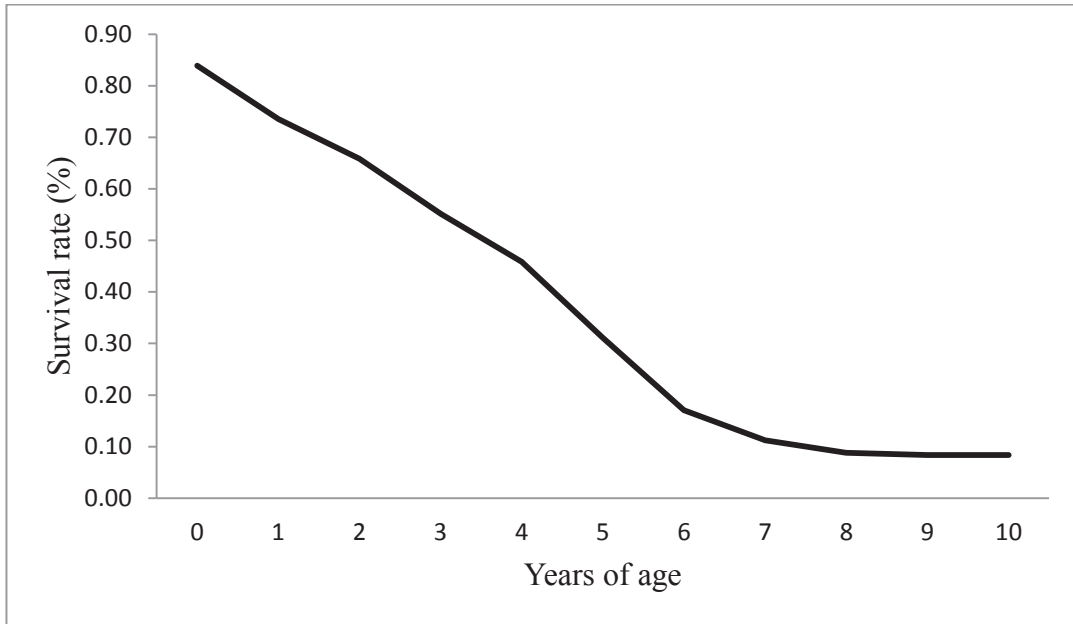

Figure 7.6. Survival rate trend using Kaplan-Meier method in New Zealand dairy goats.

Table 7.4. Range, frequencies and penalties for somatic cell count (SCC) and somatic cell score (SCS)¹ levels in dairy goats.

SCC (000)	SCS	z_i^2	Frequency	Penalty/kgMS(\$)
<900	0	-5.54	61.00	0.00
1800	6.80	0.28	20.00	-0.10
3500	7.50	0.87	11.00	-0.50
>3500	8.16	1.44	8.00	-0.50

¹SCS population mean±SD=6.48±1.17; ² $z_i = \frac{(t_i - \mu)}{\sigma}$, where terms were defined previously.

Sensitivity of economic values to changes in costs and prices

The EVs and REVs after increasing or decreasing feed costs and price/kg of MS by 15%, are shown in Table 7.6. Relative to EVs of the Current scenario, increases of 15% in feed costs caused decreases of less than 2% in the resulting positive EVs for milk-solid components, while the negative EVs for MY and LW increased 13% and 17%, respectively. A reduction of 15% in feed costs caused an increase of 1.5% in FY and 0.01% in both PY and LY. The negative EVs of MY and LW decreased 11.11% and 17.48%, respectively.

Table 7.5. Price per kilogram of milk component and economic values for different payment system scenarios in dairy goats.

Parameter	Trait	Scenario ¹							
		Current (MS)		1		2		3	
Price (NZ\$/kgMS)	FY			15.83		30.17			
	PY			31.66		15.08			
	MS	13.00							
	MY ²			-0.04		-0.04		1.51	
EVs (NZ\$/kg) ³		EV	REV	EV	REV	EV	REV	EV	REV
	FY	11.64	1.000	14.49	1.000	28.93	1.000	-1.45	1.000
	PY	12.27	1.054	31.08	2.145	14.36	0.496	-0.85	0.586
	LY	12.39	1.064	-0.76	-0.052	-0.76	-0.026	-0.76	0.524
	MY	-0.10	-0.009	-0.14	-0.010	-0.14	-0.005	1.43	-0.986
	LW	-2.15	-0.185	-2.15	-0.148	-2.15	-0.074	-2.15	1.483
NZ\$/day	LGTY	0.04	0.003	0.04	0.003	0.04	0.001	0.04	-0.028
NZ\$/score	SCS	-8.22	-0.710	-8.22	-0.570	-8.22	-0.280	-8.22	5.690

¹ Current scenario: Milk-solids (MS), MS=Fat yield (FY) + Protein yield (PY)+Lactose yield (LY)+Minerals), Scenario 1: 1FY+2PY-MY; Scenario 2: 2FY+1PY-MY; Scenario 3: MY; ²A penalty of -NZ\$0.04 was applied per litre of milk volume in Scenarios 1 and 2; ³New Zealand dollars per kg.

When an increase of 15% in the price per kg of MS was simulated in the Current scenario, the EVs for milksolid components increased between 13.7% and 14.4%, but when a decrease of 15% was simulated, a decrease between 18.9% and 20.4% was observed in the resulting EVs relative to the Current scenario EVs. Changes in prices did not affect the EVs of MY and LW. Increases or decreases in price value per kg of MS did not affect the EV for LGTY, SCS, LW and MY. The EVs were more sensitive to changes in price per kg of MS than to feed cost changes.

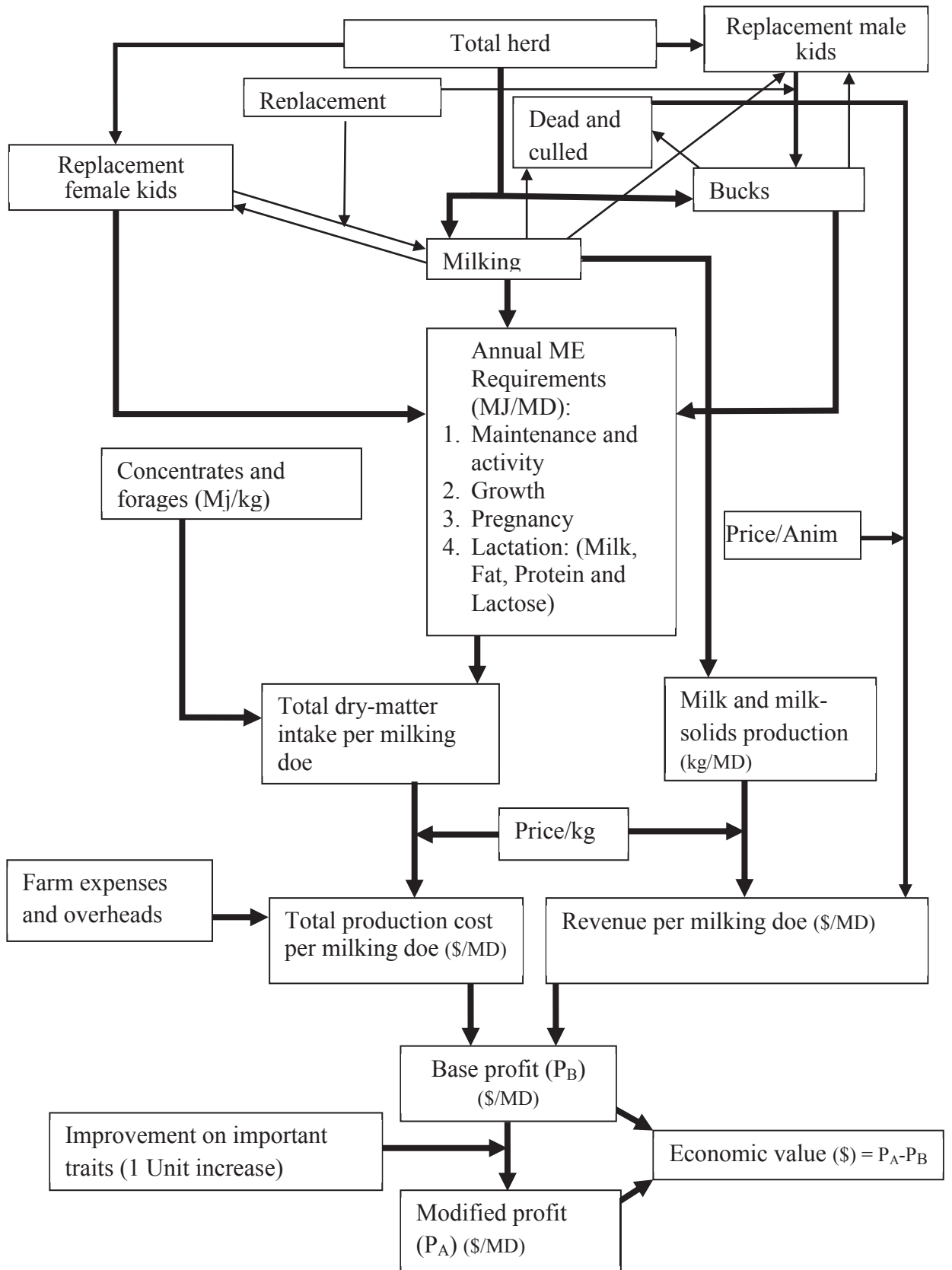

Figure 7.7. Factors accounted for in a dairy goat farm model to derive economic values.

Table 7.6. Sensitivity of economic values following changes in feed costs and milk-solids revenue by $\pm 15\%$ in the current scenario for New Zealand dairy goats.

Trait	Percentage increase							
	Feed costs				Price/kgMS ²			
	+0.15		-0.15		+0.15		-0.15	
	EV ¹	REV ¹	EV	REV	EV	REV	EV	REV
FY	11.420	1.000	11.820	1.000	13.600	1.000	9.670	1.000
PY	12.140	1.063	12.390	1.048	14.230	1.046	10.300	1.065
LY	12.280	1.075	12.500	1.058	14.360	1.056	10.420	1.078
MY	-0.120	-0.011	-0.090	-0.008	-0.100	-0.007	-0.100	-0.010
LW	-2.470	-0.216	-1.830	-0.155	-2.150	-0.158	-2.150	-0.222
LGTY	0.040	0.004	0.040	0.003	0.040	0.003	0.040	0.004
SCS	-8.220	-0.720	-8.220	-0.695	-8.220	-0.604	-8.220	-0.850

¹NZ\$/kg trait; ¹EV = Economic value and REV = Relative economic value; ² MS= kg of milk-solids.

DISCUSSION

The model

Important inputs and outputs for a New Zealand dairy goat production system were combined into a deterministic bio-economic farm model to estimate economic values for relevant animal traits affecting profit. The model was constructed to account for level of production and feed consumption and any changes in diet, production costs or the payment system. Herd structure, death and culling rate, as well as costs and expenses, payment system, nutritional requirements for MY, FY, PY, gestation, and growth and maintenance were taken into account in the model. However, for SCS, it was necessary to estimate the EV in an independent model following methodology described by Meijering (1986) for dystocia in dairy cattle, but applied to SCS by Charfeddine et al. (1997) and Sadeghi-Sefidmazgi et al. (2011) to ensure that the economic value only reflects the impact of penalties on SCS levels.

Culling and death of dairy goats throughout the years are due to many reasons already described (Solis-Ramirez et al. 2011). The most critical stage is around birth, because most deaths occur during the first months of life. The survival rate improves as goats age (Chikagwa-Malunga & Banda 2006). However, in milking does, the higher culling rate is based on productive performance and health status. High culling occurs after the first lactation, and this high rate continues for 4-5 lactations (Table 7.1). This trend of death and culling rate is similar to the estimated survival trend estimated using the

Kaplan-Meier method (Kaplan & Meier 1958) for the percentage of animals culled each year as is shown in Table 7.3.

The estimation of animal metabolisable energy and feed intake is required to plan dry-matter needs throughout the year. The daily DMI estimated in this study was 2.14 kg or 3.0% of LW. This was within the range (2.25%-7%) of previously published figures for goats (Fernandez et al. 1995; Galina et al. 1995; Hart 2008; Huston & Hart 2002; Pfister & Malechek 1986; Ramírez et al. 1990).

There is little comparable literature for dairy goat or sheep farming that has been obtained under similar circumstances to the current study. Bett et al. (2007b; 2011) published lower production costs for smallholder production systems in Kenya with higher costs for veterinary services, labour and selection compared to the Current scenario. Comparisons with dairy cattle farming in New Zealand (DairyNZ 2007, 2009, 2010) showed that indoor production systems of goats have substantially higher variable costs and more capital investment for equipment, machinery and housing; however, in absolute terms, the return on investment of the dairy goat system per hectare (10.7%) was a little lower than dairy cattle systems (11.3%) (Solis-Ramirez et al. 2011).

Economic values for traits

The bio-economic farm model was used to estimate economic values for traits affecting profit per milking doe for four scenarios. All scenarios assumed a payment equivalent to NZ\$13.00/kg of MS. Therefore, differences in value per kg for the same trait between scenarios reflect the relative importance assigned to milk-solid components in the payment system. Differences in EV between traits in the same scenario are a reflection of the prices and marginal energy cost needed to produce a unit of each trait. By changing the payment system from MS alone to a FY and PY ratio and penalising - NZ\$0.04/kg of milk yield (MY) volume, the value becomes greater than NZ\$13.00 per kg in Scenarios 1 and 2. Similarly, paying on the basis of MY only resulted in a value of NZ\$1.51 per litre of milk with no value assigned to milk-solid components in Scenario 3.

The EVs for milk components were driven by the revenue and by the DMI cost needed to increase a unit of production in a given trait.

Under the current scenario (payment for MS), the MS payment is apportioned between the milk-solid components resulting in positive EVs for FY, PY and LY. Differences between the value per kg of milk-solids and the EVs for FY, PY, and LY (NZ\$1.36, NZ\$0.73 and NZ\$0.61, respectively) are a reflection of the marginal energy costs for the three milk-solid components. Therefore, the higher energy cost or higher production cost is for FY followed by PY and LY (Table 7.5).

The EV for MY and LW was negative (-NZ\$0.10 and -NZ\$2.15, respectively). This is caused by the energy cost for producing an extra kg of milk or weight gain synthesis not being offset by an increase in revenue; further, the energy cost was needed for body maintenance and activity of the animal in the LW economic value.

An extension of an extra day in the life of a milking doe is worth an extra NZ\$0.04 revenue, thus to maximise revenue or profit farmers need to ensure longer productive life of animals, while the EV for SCS was negative (-NZ\$8.22), indicating the heavy loss of revenue for an increase in SCS.

The comparative importance of the traits relative to FY economic value is indicated by the relative economic value (REV). The REV for LY was the highest positive value, followed by PY and LGTY, while the highest negative value was for SCS, followed by LW and MY (Table 7.5).

In Scenario 1 (payment for FY+2PY-MY), the higher price per kilogram of FY and PY and a penalty of -NZ\$0.04 per kilogram of MY were reflected in a higher EV for those traits relative to the current scenario, but a low negative EV for LY and a lower EV for MY (Table 7.5). The differences between price per kilogram of FY and EV, and PY and EV were NZ\$1.34 and NZ\$0.58, respectively. These values reflect the higher production cost for a kilogram of FY and lower for PY. A negative EV for LY was estimated as a consequence of the energy cost for producing an extra kg of lactose not being offset by an increase in revenue due to no value per kilogram of LY.

As was expected, the EV for MY increased negatively from -NZ\$.10 to -NZ\$0.14 due to the penalty of NZ\$0.04 imposed for the collecting, transporting and drying of milk, while the EV for LW, LGTY and SCS remain the same with no change.

The REV for PY increase is more than twice the importance of FY, which was expected since a ratio 1:2 was set up for FY:PY, respectively. The higher positive relative

importance was first for PY, followed by LGTY, while lower negative values were first for MY, and then for LY, LW and SCS. The most important change was for LY from positive (current scenario) to negative values (Scenario 1) due to no value for LY.

In Scenario 2 (payment for 2FY+PY-MY), the higher price per kilogram of FY and PY and a penalty of -NZ\$0.04 per kilogram of MY were reflected in higher EV for those traits relative to the Current scenario, but there was a low negative EV for LY and a lower EV For MY (Table 7.5). The differences between price and EV of FY and PY were NZ\$1.24, NZ\$0.72, respectively. These values reflect the higher production cost for a kg of FY and lower cost for PY. A negative EV for LY was also and it was similar to the value estimated in Scenario 1. The EVs for MY, LW LGTY and SCS also remain the same between Scenarios 1 and 2.

Although the REVs for Scenarios 1 and 2 change in magnitude, their ranking was the same as in Scenario 1. The REV for PY was the highest value, but about 50% of the REV for FY, which was expected since in this scenario (Scenario 2) the ratio was 2:1 for FY and PY, respectively. However, important changes in magnitude were observed since the values were less negative than in the Current scenario and Scenario 1.

In the last scenario (Scenario 3 with payment for MY), the economic value for MY was NZ\$1.43 and the difference between this and price per kg of MY was NZ\$0.08, which resembles the cost of production per kg of MY. The EVs for FY and PY are negative in this scenario (-NZ\$1.45 and -NZ\$0.85, respectively) because there is no value for any milk-solid components and there is an energetic cost to produce each milk-solid trait unit. Such negative weightings for milk solids will likely decrease their concentration which in turn will be seen as undesirable by milk processors. This is very unlikely scenario for New Zealand conditions since the payment scenario is for MS. In other countries, where selection for milk yield is currently carry-on, to avoid a decreased in the concentration of milk-solid components a farm model must be developed to correctly account for cost of production and the maintenance of milk solids concentration. While Scenario 3 is an “opposite” situation to the Current scenario, the EVs for LW, LGTY and SCS are the same because of the minimal value for LW and there being no change in cost for LGTY and SCS.

The REVs relative to FY were positive and highest for SCS and then for LW, PY and LY, while MY and LGTY had negative values (-\$0.986 and -0.028, respectively). These

REVs suggested that when paying for milk yield volume, the relative importance for FY, PY, LY, LW and SCS will increase, which means higher maintenance and weight gain costs of production and higher costs due to increases in SCS.

From the previous four scenarios, the way that the value per kg of trait affects the EVs and the relative importance of each trait in each scenario can be observed. This impact on EVs was expected since production costs and revenue are the key points in any modern animal production system.

Bett et al. (2007b; 2012a) reported positive EV per doe per year for MY and LW in Kenyan goats, except for MY when smallholders' low potential due to production conditions was analysed under fixed flock size and feed resource. Under New Zealand dairy cattle grazing conditions, Harris (1998) consistently estimated lower EVs for FY and PY and smaller negative values for MY and LW which agree with the negative EVs for MY and LW found in three scenarios in this study. Visscher et al. (1994) found a similar pattern of results under Australian grazing conditions, indicating the positive effect of milk-solid components, but the negative effect of MY and LW on profit.

In dairy animals (for example cattle, goats and sheep), milk volume is still the most important trait in most countries (Carta et al. 2009). Scenario 3 reflects many situations around the world where payment is based on milk volume sales only and financial reward for milk-solids is still missing from the payment system. In Scenario 3, milk-solids did not receive payment, resulting in negative EVs for FY, PY and LY due to the energy required for synthesis.

The EV for an extra day of life for a doe in the herd was \$0.04 across all scenarios, which means that for each extra day of life per doe, a net income of four cents is expected. Previous studies in dual-purpose goats reported higher EVs (\$0.08-\$0.30) than those found in this study (Bett et al. 2007a), while an equivalent economic value of \$0.03 was estimated for dairy cattle (Harris 1998; NZAEL 2012), which suggests that the importance of LGTY is different for each production system, but fairly similar in dairy animals.

Recent EVs for SCS in dairy goats published by Bett et al. (2012a) and Lopes et al. (2012) in dairy goats are lower (from -US\$1.34 to -US\$4.50) than the value estimated in this study (-NZ\$8.22). Other values estimated in dairy sheep (Legarra et al. 2007)

were lower (from -US\$1.91 to -US\$4.28) than the values in this study. However the value in this study is in the range of EV estimated for dairy cattle in New Zealand (EV = -\$38.57) (NZAEL 2012) if a liveweight equivalent of 4 to 7 milking does are similar to a cow weighting between 340 kg and 540 kg, respectively. For example, $340/80.2=4.2$ and $540/80.2=6.7$, these values result in EV for SCS ranging from -NZ\$5.51 to -NZ\$9.64. Other studies in dairy cattle (Sadeghi-Sefidmazgi et al. 2011) ranged from -US\$69.75 to -US\$93.00. Using the liveweight equivalent for this range, the EVs were from -US\$17.44 to -US\$23.25 for 4 milking does equivalent to a cow, and from -US\$9.96 to -US\$13.29 for 7 milking does equivalent to a cow. Economic values are expected to change with particular conditions of each production system due to variation in feed costs, management and revenue and they need to be updated periodically.

Sensitivity analysis

Genetic improvement takes two generations to flow through the herd, by which time revenue/costs may have changed. A sensitivity analysis examines whether fluctuations in values change the EVs of the important traits in the breeding programme.

A 15% increase in feed costs decreased the EVs for MS components by $\pm 2\%$. However, greater changes were observed in LW and MY as a result of increases in the cost for feed required to increase weight gain and maintenance (20% and 14.9%, respectively). LGTY and SCS economic values were not affected.

A 15% decrease in feed costs also resulted in an increase in the EVs for MS components by $\pm 2\%$. However, greater changes of -10 and -14.8% were observed in MY and LW, respectively as a result of reducing in cost for feed required to increase weight gain and maintenance. LGTY and SCS economic values were not affected.

A 15% increase in the value of kg of MS increased the EVs for MS components by 16-17%. However, the EVs for MY, LW, LGTY and SCS were not affected. A 15% decrease in the value of a kg of MS reduced the EVs for MS components by 16-17%, but the EVs for MY, LW, LGTY and SCS were not affected.

The REVs keep the same ranking across increases and decreases by 15% of feed costs and price per kg of MS. However, the higher negative relative importance for LW was

when feed costs increase and when price per kg of MS decreases by 15%; a similar outcome was observed for MY when feed cost was reduced by 15 % and price per kg of MS was increased by 15 %. These synergic changes are explained by the way that increases in feed costs affect costs of production, while increases in price impacts on total revenue. Therefore, similar influences on the EV figure will be expected by a reduction of feed costs or an increase of price figures per kg of MS.

The EVs for MY and LW were not affected when price/kg of MS was changed because there was no price for V and LW, but they were sensitive to change in feed costs because of feed requirements to increase a unit of those traits.

The sensitivity of EVs to feed costs and milk revenue changes was also noted by Bett et al. (2007b) and Lopes et al. (2012) for different dual-purpose or dairy goat production systems. They increased and decreased the feed costs and price per kg of milk by 20% and pointed out that EVs were relatively stable for those changes. Studies in dairy cattle grazing production systems in New Zealand, Australia and Ireland show that increases and decreases in feed costs and revenue by 20% did not drastically modify the EVs sensitivity to changes in feed costs and prices, keeping a relative stable REV figure (Harris 1998; Veerkamp et al. 2002; Visscher et al. 1994). In this study, the sensitivity analysis showed that changes in feed costs and revenue did not affect the relative importance of the traits when changes of $\pm 15\%$ could be imposed by changes in market, financial rates or inflation rates.

CONCLUSIONS

The bio-economic model is one that integrates different modules or sources of costs of production, revenue, herd structure, energy requirements, dry-matter intake, pregnancy, growth, maintenance and milk traits yield to accurately describe the impact of independent changes in traits. It is also able to estimate economic values as a result of increases in a unit of a particular trait. This model ensures an accurate estimation of profit, avoiding double counting due to independency of the modules involved to estimate changes in traits. The EVs showed to be dependent on the payment system on traits, with EVs changing with each scenario.

The EVs are more sensitive to changes in revenue than in feed cost, but mostly fairly stable. These EVs should be used in the structure of a selection index to increase profit per milking doe in New Zealand dairy goats.

CHAPTER 8
ESTIMATION OF GENETIC PARAMETERS FOR MILK TRAITS AND
SOMATIC CELL SCORE IN NEW ZEALAND DAIRY GOATS

ABSTRACT

The New Zealand dairy goat industry is focussed on the production of milk powder for international markets. Routine genetic evaluation for the identification of superior animals requires knowledge of the genetic parameters for traits of economic importance. Repeatabilities, heritabilities, genetic and phenotypic correlations for lactation yields of milk (MY), fat (FY) and protein (PY) and for somatic cell score (SCS) were estimated in this study. The data set comprised 43,147 lactations from 18,674 milking does, 665 bucks from 35 dairy goat farms, 10 years, and 10 breed groups supplying the Dairy Goat Cooperative (DGC) from the region of Waikato, New Zealand. Estimates of (co) variances were obtained using the ASReml 3.0 software package using uni- and bivariate trait animal models. The models included contemporary group (does kidding in the same herd, year and month), parity number, breed group, and individual heterosis as fixed effects, and random additive genetic and permanent animal effects. Heritability values for MY, FY, PY were 0.21 for each trait and for SCS was 0.22 with standard errors ranging from 0.012 to 0.014, while repeatabilities were 0.41 (0.006), 0.40 (0.006), 0.40 (0.006) and 0.49 (0.006), respectively. Genetic and phenotypic correlations among milk traits were high (ranging from 0.88 to 0.97), while among milk traits and SCS were low (ranging from -0.17 to 0.04). Estimates of genetic variances and covariances will be used to structure a multi-trait selection index to improve the profitability per milking doe of the dairy goat herds organized by the Dairy Goat Cooperative of Waikato, New Zealand.

Keywords: Dairy goats, heritability, genetic correlations, genetic parameters, Milk traits, fat yield, protein yield, SCS.

INTRODUCTION

Goats are very versatile animals and can be found in most agro-ecological systems around the world (Devendra 2013). Goat milk is one of the most consumed milks and plays an important role in human nutrition, either as fluid milk or being processed into high quality cheeses, yoghurt, candies or other products. It is also used in the making of beauty products.

The New Zealand dairy goat farming industry is a profit dependent enterprise, and milk traits are relevant in the pursuit of the breeding goal. Dairy goat traits have not been

adequately studied from a genetic selection perspective. Therefore, further research is needed regarding genetic, environmental and phenotypic variances as well as covariances between traits. These parameters should then be used together with economic values to define a breeding objective as part of a selection index scheme to improve dairy goat herds. A holistic dairy goat production system is only possible if a genetic improvement programme includes production and functional traits to ensure adequate production levels and healthy animals.

Genetic evaluation of dairy goats in New Zealand is a recent practice and genetic parameter and breeding value estimation have been reported for some herds from the central-north and north of the North Island of New Zealand around the areas of Waikato and Northland (Apodaca-Sarabia et al. 2009; Lopez-Villalobos & Garrick 2001; Morris et al. 1997; Morris et al. 2006; Singireddy et al. 1997). However, for most herds, breeding values are not estimated and selection is based only on phenotypes. For a small number of herds breeding value estimates are run routinely, but the selection of replacements is on dam phenotype.

Genetic parameter estimation is a basic step when designing a comprehensive genetic improvement programme aimed at increasing trait production, efficiency and profitability at the farm or animal level. It is also a required step to develop a selection index that includes traits of economic importance and to predict direct and correlated responses from a selection programme.

Genetic parameters can be estimated effectively using univariate and multivariate repeatability animal models (Torres-Vazquez et al. 2010b; Torres-Vázquez et al. 2009; Valencia et al. 2005). Alternatively, a combination of univariate and multi-variate trait animal and repeatability models with random regression models (Menéndez-Buxadera et al. 2010; Zumbach et al. 2008) can be used. For the first approach, a data ‘cleaning’ is needed allowing animals with a variable number of records to be analysed, for example four or more TDR. In the second approach, using random regression animal repeatability models, a more efficient use of test day records is achieved, reducing the required number of test day milk recordings per lactation. This reduces the cost of milk recording and, therefore, should increase farm profit. The estimation of genetic parameters using RRM test day models are more flexible in comparison to only test day models assuming only a fixed lactation curve, accounting for the shape of lactation

curves, as they allow each animal to have a different shape of lactation curve on a genetic level (Jamrozik et al. 1997).

The objective of this study was to estimate genetic and phenotypic parameters (heritability, repeatability as well as genetic and phenotypic correlations) for milk (MY), fat (FY), and protein (PY) yield as well as for somatic cell score (SCS) trait using a multi-trait random regression animal model.

MATERIALS AND METHODS

Data, traits and herd

The New Zealand Dairy Goat Cooperative (DGC) located at Hamilton, Waikato, New Zealand, provided data for a total of 43,147 lactations from 18,674 milking does and 665 bucks. There were 658 contemporary groups identified, from 35 dairy goat herds, 20 years of recording and 10 breed groups. This DGC database contained information on MY, FY, PY and SCC information.

The total MY, FY and PY to 270 day lactation lengths were estimated using the Wilmink model (Wilmink 1987a) and random regression models (RRM) with the ASReml 3.0 software package (Gilmour et al. 2009). The average Somatic cell score was estimated using the herd test records of somatic cell count as a logarithm based 2 transformed as $SCS = \log_2(SCC)$.

The general features of the farming system were described by Solis-Ramirez et al. (2011). Briefly, the dairy goats were kept indoors and the herd structure consisted of 18.6% 0-1 year olds; 14.5% 1-2 year olds; 12.9% 2-3 year olds; 10.8% 3-4 year olds; 8.8% 4-5 year olds; 4.9% 5-6 year olds; 2.7% 6-7 year olds; 1.6% 7-8 year olds; 1.2% 8-9 year olds; 1.1 % 9-10 year olds; and 0.9% 10+ year olds. The herd was 97.5% Saanen or Saanen by Toggenburg crosses, and the remaining 2.5% were mainly British Alpine, Nubian and Saanen by British Alpine and Saanen by Nubian crosses. Milking goats kid once a year and they were milked twice a day for a range of 13 to 305 days in milk. A highly seasonal kidding period occurred between June and October.

Estimation of variances and covariances

The variances needed to estimate heritabilities and repeatabilities and the covariances need to estimate genetic and phenotypic correlations and their standard errors were

estimated with restricted maximum likelihood (REML) procedures using the ASReml 3.0 software package (Gilmour et al. 2009) for univariate and bivariate analysis.

Univariate analysis

The univariate repeatability animal model (Henderson 1973; Mrode 2005) was:

$$\mathbf{y} = \mathbf{Xb} + \mathbf{Za} + \mathbf{Wu} + \mathbf{e}$$

where:

- \mathbf{y} = vector of total milk trait yield or SCS observations;
- \mathbf{b} = vector containing all fixed effects;
- \mathbf{a} = vector of additive random animal effects;
- \mathbf{u} = vector of random animal permanent environmental affects;
- \mathbf{X} = incidence matrix relating records to fixed effects;
- \mathbf{Z} = incidence matrix relating records to additive random animal effects;
- \mathbf{W} = incidence matrix relating the records to random animal permanent environmental effects; and
- \mathbf{e} = Random residual error vector.

The \mathbf{Z} matrix allows inclusion of sire and dams related to does with records and \mathbf{W} is an identity matrix. The fixed effects included in \mathbf{b} were contemporary group (does kidding in the same herd, year and month), parity number, breed group and individual heterosis.

The following assumptions were made:

Assumptions:

$$\begin{aligned} E(\mathbf{y}) &= \mathbf{Xb}; \\ E(\mathbf{a}) &= 0; \text{ and} \\ E(\mathbf{e}) &= 0; \end{aligned}$$

Variances (var):

$$\text{var} \begin{bmatrix} \mathbf{a} \\ \mathbf{p} \\ \mathbf{e} \end{bmatrix} = \begin{bmatrix} \mathbf{A}\sigma_a^2 & 0 & 0 \\ 0 & \mathbf{I}\sigma_p^2 & 0 \\ 0 & 0 & \mathbf{I}\sigma_e^2 \end{bmatrix} \text{ and}$$

$$\text{var}(\mathbf{y}) = \mathbf{ZAZ}'\sigma_a^2 + \mathbf{WI}\sigma_p^2\mathbf{W}' + \mathbf{R}$$

where:

- σ_a^2 = additive animal effect variance;
- σ_p^2 = animal permanent effect variance;
- σ_e^2 = random residual variance;

A = the numerator relationship matrix between all animals considered in the data set; and

$$R = var(e) = I\sigma_e^2$$

The numerator relationship matrix was based on the knowledge of the pedigree relationship of parents and offspring suggested by Mrode (2005). The file included sires and dams of milking does.

The mixed model equations used for the estimation of fixed effects, prediction of genetic parameters and the effect of permanent environmental effects are presented as:

$$\begin{bmatrix} X'X & X'Z & X'W \\ Z'X & Z'Z + A^{-1} \alpha_1 & Z'W \\ W'X & W'Z & W'W + I \alpha_2 \end{bmatrix} \begin{bmatrix} \hat{b} \\ \hat{a} \\ \hat{p} \end{bmatrix} = \begin{bmatrix} X'y \\ Z'y \\ W'y \end{bmatrix}$$

where:

$$\alpha_1 = \frac{\sigma_e^2}{\sigma_a^2} \text{ and } \alpha_2 = \frac{\sigma_e^2}{\sigma_p^2}$$

With estimated solution:

$$\begin{bmatrix} \hat{b} \\ \hat{a} \\ \hat{p} \end{bmatrix} = \begin{bmatrix} X'X & X'Z & X'W \\ Z'X & Z'Z + A^{-1} \alpha_1 & Z'W \\ W'X & W'Z & W'W + I \alpha_2 \end{bmatrix}^{-1} \begin{bmatrix} X'y \\ Z'y \\ W'y \end{bmatrix}$$

Bivariate analysis

In a multivariate analysis for two traits (bivariate analysis), the following assumptions were made:

Assumptions:

$$E(\mathbf{y}_1) = \mathbf{X}_1 \mathbf{b}_1 \text{ and } E(\mathbf{y}_2) = \mathbf{X}_2 \mathbf{b}_2;$$

$$E(\mathbf{a}_1) = 0 \text{ and } E(\mathbf{a}_2) = 0;$$

$$E(\mathbf{e}_1) = 0 \text{ and } E(\mathbf{e}_2) = 0,$$

The random effects were assumed to be normally distributed with zero mean and the following covariance structure:

$$var \begin{bmatrix} \mathbf{a}_1 \\ \mathbf{a}_2 \\ \mathbf{p}_1 \\ \mathbf{p}_2 \\ \mathbf{e}_1 \\ \mathbf{e}_2 \end{bmatrix} = \begin{bmatrix} A\sigma_{a_{11}}^2 & A\sigma_{a_{12}} & 0 & 0 & 0 & 0 \\ A\sigma_{a_{21}} & A\sigma_{a_{22}}^2 & 0 & 0 & 0 & 0 \\ 0 & 0 & I_1\sigma_{p_{11}}^2 & I_1\sigma_{p_{12}} & 0 & 0 \\ 0 & 0 & I_1\sigma_{p_{21}} & I_1\sigma_{p_{22}}^2 & 0 & 0 \\ 0 & 0 & 0 & 0 & I_2\sigma_{e_{11}}^2 & I_2\sigma_{e_{12}} \\ 0 & 0 & 0 & 0 & I_2\sigma_{e_{21}} & I_2\sigma_{e_{22}}^2 \end{bmatrix}$$

where:

var = variance;

\mathbf{a} = the vector of random additive effect for the animal;

\mathbf{p} = the vector of random permanent effect of animal (doe);

\mathbf{e}_1 and \mathbf{e}_2 = random residual effects of the trait;

\mathbf{A} = relationship matrix;

$\sigma_{a_{12}}$ (or $\sigma_{a_{21}}$), $\sigma_{p_{12}}$ (or $\sigma_{p_{21}}$) and $\sigma_{e_{12}}$ (or $\sigma_{e_{21}}$) = are additive covariance, permanent effects covariances and residual error covariances between the traits, respectively;

$\sigma_{a_{11}}^2$ and $\sigma_{a_{22}}^2$ = additive variances matrix of the traits;

$\sigma_{p_{11}}^2$ and $\sigma_{p_{22}}^2$ = permanent effects variances of the traits;

$\sigma_{e_{11}}^2$, and $\sigma_{e_{22}}^2$ = the random residual variances of the traits;

\mathbf{I}_1 and \mathbf{I}_2 = identity matrices, and

1 and 2 refers to trait 1 and trait 2, respectively.

Estimation of genetic parameters

Heritability for trait i (h_i^2) was estimated as the proportion of additive genetic variance for trait i of the total phenotypic variance under a half-sib analysis: Heritability values in the bivariate analysis were taken as the un-weighted average value of all estimated heritability combinations of the traits.

The repeatability of trait i (t_i) was estimated as a proportion of the total variance due to the permanent variance; while the genetic and phenotypic correlations between traits were estimated as the proportion of the genetic or phenotypic covariance between two traits divided by the product of the square root of the two genetic variances of the traits:

RESULTS

Heritability and repeatability estimates

Estimates of variance components, heritability and repeatability are presented in Table 8.1. The heritabilities estimated by univariate analysis were 0.21 for each of the traits, except for SCS with a 0.22 value. Using bivariate analysis resulted in no changes in heritability estimates and minor changes in the magnitude of the standard errors. Repeatability values were also similar across all traits (range 0.40 to 0.49) (Table 8.1).

Table 8.1. Estimations of (Co) variances, genetic and phenotypic parameters (standard errors) for milk traits and somatic cell score in New Zealand dairy goats.

Trait	Variances and parameters: Univariate analysis			
	Additive ¹	Phenotypic ¹	Heritability	Repeatability
Milk yield	9413.27	45247.92	0.21(0.012)	0.41(0.006)
Fat yield	11.93	56.73	0.21(0.013)	0.40(0.006)
Protein yield	7.69	37.46	0.21(0.012)	0.40(0.006)
Somatic cell score	0.31	1.44	0.22(0.014)	0.49(0.006)

Trait	Parameters ² : Bivariate analysis			
	Milk yield	Fat yield	Protein yield	Somatic cell score
Milk yield		0.91(0.001)	0.97(4x10 ⁻⁴)	-0.12(0.006)
Fat yield	0.82(0.012)		0.93(8x10 ⁻⁴)	-0.17(0.006)
Protein yield	0.93(0.005)	0.88(0.009)		-0.10(0.006)
Somatic cell score	0.04(0.04)	-0.10(0.045)	3x10 ⁻⁴ (0.046)	

¹ additive and phenotypic refers to additive genetic and phenotypic variances, respectively. ² Phenotypic correlations above the diagonal and genetic correlations below the diagonal.

Genetic and phenotypic correlations

The estimated values for genetic and phenotypic correlations are presented in Table 8.1. Genetic correlations between MY, FY and PY ranged from 0.82 to 0.93. The correlations of the same traits with SCS were low and ranged from -0.10 to 0.04.

Estimates of phenotypic correlations between MY, FY and PY ranged from 0.91 to 0.97, while the correlations of these production traits with SCS were in the low negatives ranging from -0.17 to -0.10 (Table 8.1).

DISCUSSION

Heritability and repeatability

A subset of genetic and phenotypic parameters from the literature is presented in Table 8.2. More comprehensive lists of genetic parameters for economically important traits in dairy goats, dairy cattle and sheep are presented in Appendixes (Appendix 8.1, Appendix 8.2 and Appendix 8.3).

The heritabilities estimated for milk yield traits and SCS were within the range of values reported in the literature (Table 8.2 and Appendix 8.1). These values were also lower than those previously reported for New Zealand goat herds (Lopez-Villalobos & Garrick 2001; Morris et al. 1997; Morris et al. 2006; Morris et al. 2011) (Tables 8.2 and 8.3). Values estimated for Lopez-Villalobos & Garrick (2001) and Morris et al. (1997) were similar to the values estimated in this study for milk, fat and protein yield. However, values estimated in this study for fat and protein yield were lower than those reported by Morris et al. (2011). Differences in these estimates could be due to earlier genetic selection applied since 2001 in the DGC herds (Lopez-Villalobos & Garrick 2001) reducing actual genetic variability; furthermore, estimations in this study were with higher number of TDR, does and bucks reflected in lower standard errors.

The estimated heritabilities values suggest that all the traits are moderately heritable and repeatable. Therefore, selecting for milk traits should result in moderate genetic gains for that traits; while selecting for SCS should provide with low genetic change.

Heritability values in the bivariate analysis were taken as the average value of all combinations of the traits, and they were similar to those estimated in the univariate analysis (Table 8.1). These results suggest that heritability and repeatability can be estimated in a bivariate analysis while estimating correlations between traits and no need for a separate univariate analysis.

The t_i estimations in this study for MY, FY and PY were similar to those reported by Lopez-Villalobos & Garrick (2001) from herds organised in the DGC of New Zealand, which are included in the data base used for this study; however, the standard errors in this study were lower due to the use of more TDR for this study.

There is a lack of published papers on repeatability estimates for SCS in goats. Repeatability value for this study were lower than those previously reported by

Apodaca et al. (2009), but higher than the value reported by Morris et al. (2011) (Table 8.2). In dairy cattle, higher values were estimated by several authors (Appendix 8.2).

Genetic and phenotypic correlations

Genetic correlations of MY with FY and with PY were high (0.82 and 0.93, respectively), while the value between MY and SCS was low (0.04). Genetic correlation between actual and predicted values for MY was 1.0, showing that actual and predicted values have the same characteristics.

Genetic correlations between MY and SCS in goats is scarce in the literature; however, the 0.04 value estimated in this study was within the range of values reported by Rupp et al. (2011), but higher than the value reported by Morris et al. (2011) using a Log₁₀ SCS estimation when in this study a log₂ SCC was used. In dairy cattle, values ranging from -0.13 to 0.18 have been noted (Appendix 8.2). There has been a wider range in sheep (-0.30 to 0.18) (Appendix 8.3).

The genetic correlations between FY and PY in this study were high and similar to those values reported in previous studies in dairy goats and higher values were reported in dairy cattle (Appendix 8.2).

Genetic correlations between PY and SCS was very lowly positive, while estimates reported by Morris et al. (2011) were lowly negative. Value estimated in the present study was within the range of low values reported in previous studies in dairy cattle (Appendix 8.1), but lower than those of sheep (Appendix 8.3). Genetic correlation between PY and PPY was 1.0 indicating that actual and predicted PY are the same trait.

Phenotypic correlations between MY and FY, MY and PY and between FY and PY were high, ranging from 0.91 to 0.97. Similar values were reported by Lopez-Villalobos and Garrick (2001) in dairy goats and by Miglior et al. (2007) in dairy cattle. However, Analla et al. (1996) described moderate negative values in Murciano-Granadina dairy goats from Spain (Table 8.2).

Table 8.2. Heritabilities, repeatabilities, genetic and phenotypic correlations in goats for Milk Yield (MY), fat yield (FY), protein yield (PY) and somatic cell score (SCS)¹.

Trait	Traits				t_i^2	Reference
	MY	FY	PY	SCS		
MY	0.25	0.81	0.93		0.42	Lopez Villalobos & Garrick (2001)
	0.18	-0.48	-0.47		0.39	Analla et al. (1996)
	0.17					Torres-Vazquez et al. (2009)
	0.23				0.26	Morris et al.(1997)
	0.34				0.52	Morris et al.(2006)
	0.39			-0.21	0.52	Morris et al.(2011)
	0.28				0.56	Zumbach et al. (2008)
	0.30-					Rupp et at. (2011)
	0.34					
	0.28-					Boichard et al. (1989)
	0.72					
	0.24					Rabasco et al. (1993)
	0.19-				0.33-	Menedez-Buxadera et al. (2010)
	0.22				0.41	
	0.22				0.40	Valencia et al. (2007)
	0.37				0.52	Tholon et al. (2001b)
		0.93	0.96		Zaharia et al. (2011)	
					Breznik et al. (2000)	
FY	0.90	0.24	0.88		0.41	Lopez Villalobos & Garrick (2001)
		0.36		-0.24	0.48	Morris et al. (2011)
		0.19				Torres-Vazquez et al. (2009)
		0.20				Rabasco et al.(1993)
	-0.02	0.35				Rupp et at. (2011)
	to	0.32				
	0.13					
	0.52-	0.22 to				Boichard et al. (1989)
	0.93	0.64				
	-0.89	0.16	0.54		0.36	Analla et al. (1996)
0.86					Lopes et al. (2012)	
	0.18			0.35	Menedez-Buxadera et al. (2010)	
PY	0.96	0.92	0.25		0.42	Lopez Villalobos & Garrick (2001)
			0.41	-0.18	0.54	Morris et al. (2011)
	-0.65	0.93	0.25		0.47	Analla et al. (1996)
			0.04			Rabasco et al. (1993)
	0.86	0.78 to	0.42 to			Boichard et al. (1989)
	to	0.94	0.59			
	0.95					
			0.17			Torres-Vazquez et al. (2009)
-0.04		0.31			Rupp et at. (2011)	
to		to				
0.06		0.31				
0.96					Lopes et al. (2012)	
SCS				0.19	0.53	Apodaca et al. (2009)
	-0.01	-0.12	-0.05	0.20	0.37	Morris et al. (2011)

...continuation Table 8.2.

	0.15	Bett et al. (2012a)
0.00 to	0.20	Rupp et at. (2011)
0.12	to	
	0.24	

¹Heritabilities (bold) are on the diagonal, genetic correlations below diagonal and phenotypic correlations above diagonal. ² t_i is repeatability of the i -trait.

Estimations between actual and predicted values for MY, FY and PY ranged from 0.95 to 1.0 indicating the high phenotypic association between actual and predicted traits, which can be also treated as the same trait (Table 8.1).

Phenotypic correlations between SCS and MY, SCS and FY and SCS and PY were negative and ranged from -0.12 to -0.17; similar negative trends were reported by Morris et al. (2011) for New Zealand goats; however, their values were slightly higher. Lower negative values were reported in dairy cattle for same traits (-0.02 to -0.09), but positive low values have also been estimated in dairy cattle (0.04-0.012) (Appendix 8.2). In sheep most positive estimates ranged from 0.03 to 0.27 (Appendix 8.3), while a few negative values were found ranging from -0.14 to -0.30 (Appendix 8.3).

These high correlation values imply that selection to increase any of the milk yield traits result in increases of the traits. The low correlation value between SCS and milk traits estimated in this study and the low negative value in other studies indicates that increases in MY will result in an increase or reduction in SCS. The high values of the genetic and phenotypic correlations between actual and predicted trait yield suggest that they can be treated as one trait and therefore there is no need to work those traits are different traits in research studies.

CONCLUSIONS

The moderate values of heritability, repeatability and the high positive genetic and phenotypic correlations between milk traits and the negative low correlations between milk traits and SCS suggests favourable genetic gain that can be expected if these values are used in a breeding objective to improve economically important traits in dairy.

APPENDICES TO CHAPTER 8

Appendix 8.1. Heritabilities, repeatabilities and genetic and phenotypic correlations for some important traits in dairy goats¹.

Trait	Traits										Reference	
	MY	FY	PY	LY	LW	LGTY	SCS	MS	t_i^2			
MY	0.39				0.25							Morris et al. (2011)
	0.25	0.81	0.93						0.42			Lopez Villalobos & Garrick (2001)
	0.18	-0.48	-0.47						0.39			Analla et al. (1996)
	0.17											Torres-Vazquez et al. (2009)
	0.28								0.56			Zumbach et al. (2008)
	0.34											Rupp et at. (2011)
	and											
	0.30											
	0.28											Boichard et al. (1989)
	to 0.72											
	0.24											Rabasco et al. (1993)
	0.17			0.75				0.84				Montaldo et al. (2010)
					0.04							Mavrogenis & Papachristoforu, (2000)
	0.19 to								0.33 to			Menedez-Buxadera et al. (2010)
	0.22								0.41			
	0.22								0.40			Valencia et al. (2007)
	0.37								0.52			Tholon et al.(2001a)
	0.20											Breznick et al. (2000)
FY	0.90	0.24	0.88						0.41			Lopez Villalobos & Garrick (2001)

...continuation Appendix 8.1.

	0.36			0.25		Morris et al. (2011)
	0.19					Torres-Vazquez et al. (2009)
	0.20					Rabasco et al. (1993)
	0.35					Rupp et al. (2011)
	-0.02 to -0.13					
	0.32					
	0.22					Boichard et al. (1989)
	0.52 to 0.93					
	to .64					
	0.16	0.54				Analla et al. (1996).
	0.18					Lopes et al. (2012)
	0.86					Menedez-Buxadera et al. (2010)
	0.22		0.55		0.74	Montaldo et al. (2010)
PY	0.96	0.92	0.25		0.42	Lopez Villalobos & Garrick (2001)
			0.41	0.32		Morris et al. (2011)
	-0.65	0.93	0.25		0.47	Analla et al. (1996)
			0.04			Rabasco et al. (1993)
	0.86 to 0.95	0.78 to .94	0.42 to .59			Boichard et al. (1989)
			0.17			Torres-Vazquez et al. (2009)
	-0.04 to 0.06		0.34 to 0.31			Rupp et al. (2011)
	0.96		0.19	0.65	0.80	Montaldo et al. (2010)
						Lopes et al.(2012)
LY	0.82	0.32	0.42	0.14	0.37	Montaldo et al. (2010)
	0.98	0.89	0.94	0.15	0.27	Lopes et al. (2012)

...continuation Appendix 8.1.

									Torres-Vazquez et al. (2010b)
									Morris et al. (2011)
LW									Bett et al., (2011)
									Thiruvenkadan et al., (2009)
									Faruque et al. (2010)
									Avg authors quoted by Shrestha et al. (2007a)
	0.38	0.39	0.47		0.25	0.27	0.8		Morris et al. (2011)
	0.11								Mavrogenis & Papachristoforou (2000)
LGTY				0.1					Bett et al.(2012a)
				0.04					Wheeler et al. (2013)
SCS									Apodaca et al. (2009)
					0.19		0.53		Bett et al. (2012a)
	0.00 to				0.15				Rupp et at. (2011)
	0.12				0.20 to				
					0.24				
					0.2	-0.21			Morris et al. (2011)
MS	0.89	0.83	0.80	0.88					Montaldo et al. (2010)
				0.41	-0.07				Morris et al. (2011)
									Rabasco et al. (1993)

¹Values from literature: Heritabilities (bold) are on the diagonal, genetic correlations below diagonal and phenotypic correlations above diagonal. ² t_i is repeatability of the i -trait.

Appendix 8.2. Heritabilities, genetic and phenotypic correlations for some economically important traits in dairy cattle¹.

Traits	Traits							Reference	
	MY	FY	PY	LY	LW	LGTY	SCS		t_i
MY	0.32								Jamrozik & Schaeffer (1997)
				0.96			-0.06		Charfeddine et al., (1997)
							-0.07		Welper & Freeman (1992)
					0.28		0.04		Weller & Ezra (1997)
	0.27	0.66	0.89	0.98					Pryce & Harris (2006)
					0.41				Johnson et al. (2000)
		0.79	0.94	0.99					Vukasinovic et al.(1995)
									Miglior et al. (2007)
FY		0.81	0.77				-0.06		Miglior et al. (2007)
					0.33		0.12		Pryce & Harris (2006)
							-0.04		Charfeddine et al. (1997)
							-0.05		Weller & Ezra (1997)
	0.16	0.26	0.65						Johnson et al. (2000)
						0.39			Vukasinovic et al. (1995)
PY							-0.02		Charfeddine et al. (1997)
							-0.03		Weeler et al. (1996)
					0.34		0.06		Pryce & Harris (2006)
	0.72		0.21	0.88					Johnson et al. (2000)
						0.39			Vukasinovic et al. (1995)
				0.92			-0.06		Miglior et al. (2007)
LY	0.95	0.15	0.7	0.26					Johnson et al. (2000)
	0.98			0.49			-0.11		Miglior et al. (2007)

...continuation Appendix 8.2.									
	0.92	0.25		0.45	Welper & Freeman (1992)				
		-0.01			Pryce & Harris (2006)				
LW	0.25	0.24	0.30	0.39	Pryce & Harris (2006)				
LGTY					Harris (1989b)	0.03			
					Samore et al. (2008)	0.07			
					Jairath et al. (1998)	0.03			
					Boettcher et al. (1999)	0.04			
	0.84	0.71	0.75		Vukasinovic et al. (1995)	0.13			
					Vukasinovic et al. (2001)	0.18			
					Boldman et al.(1992)	0.03			
				-0.45	Pritchard et al.(2013)	0.06			
SCS				0.15	Weeler et al. (1996)				
				0.13	Welper & Freeman (1992)				
	-0.04	0.01	0.00	0.27	Pritchard et al. (2013)				
	0.04				Luttien & Juga, 2013	0.18			
	0.15	0.14	0.16		Charfeddine et al.(1997)	0.13			
	-0.13	-0.09	-0.09	0.04	Pryce & Harris, 2006	0.18			
	0.14				Jamrozik & Schaeffer (2012)	0.17			
	0.18	0.02	0.2		Weeler et al. (1996)				
	0.01	-0.05	0.01	-0.02	Harris et al. (2005)	0.06 to 0.21			
				-0.11	Miglior et al. (2007)	0.26			

¹Values from literature: heritabilities (bold) are on the diagonal, genetic correlations below diagonal and phenotypic correlations above diagonal, t_i is repeatability of i -trait.

Appendix 8.3. Heritabilities and genetic correlations in sheep for SCS with milk (MY), fat (FY) and protein (PY) yield traits in dairy goats.

Traits	SCS	Reference
MY	0.18	Rupp et al.(2003)
	0.15	Barrillet et al. (2001)
	0.15	Rupp & Boichard (1999)
	-0.30	Legarra et al. (2007)
	-0.14	Serrano et al. (2003)
FY	0.11	Rupp & Boichard (1999)
	0.04	Rupp et al. (2003)
PY	0.27	Rupp & Boichard (1999)
	0.03	Rupp et al. (2003)
SCS	0.13	Rupp et al. (2003)
	0.17	Rupp & Boichard (1999)
	0.13	Legarra et al. (2007)

CHAPTER 9
SELECTION SCHEMES FOR NEW ZEALAND DAIRY GOATS

ABSTRACT

A selection index for economically important traits was developed for three selection schemes and four breeding objectives for dairy goats from the Waikato region of New Zealand to estimate the genetic gain in the objective and traits in breeding objective. The three selection schemes were pedigree selection using either one lactation (PS1) or an average of three lactations (PS3) on the dam and progeny testing (PT). The four breeding objectives were based on different payment schemes: the current (T_{CBO}) was on for milk-solids (MS); a 1:2 ratio for FY and PY (T_{BO2}), a ratio 2:1 for FY and PY (T_{BO2}) and MY only (T_{BO3}). The traits in the breeding objective were milk yield (MY), fat yield (FY), protein yield (PY), lactose yield (LY), liveweight (LW), longevity (LGTY) and somatic cell score (SCS). Three selection indexes were applied that included from one (MS) to three traits (MY, FY and MY) according to the payment system. Each selection index was worked out to each breeding objective and selection scheme. Genetic parameters for traits in the four breeding objectives were estimated in Chapter 8 or taken from the literature. Selection pressures and replacement rates were applied according to the average number of bucks and does in the assumed herd size and structure for the selection schemes. The PT had the highest genetic gain in the objectives and in most of the individual traits, followed by PS3 and then PS1. Milk yield increased in all breeding objectives, but greater increase was observed in T_{BO3} . Milk components all increased except LY in both T_{BO1} and T_{BO2} . Liveweight increased in all breeding objectives, but higher increases were observed in both T_{BO1} and T_{BO2} . The highest increase in total milk-solids was in T_{CBO} followed by T_{BO3} , but similar milk-solids production in both T_{BO1} and T_{BO2} . Longevity increases in both T_{CBO} and T_{BO3} , but a decrease was observed from PS3 to PT after an increase from PS1 to PS3 in T_{BO1} and T_{BO2} . SCS decreased in breeding objectives T_{CBO} and T_{BO3} , but increased in T_{BO1} and T_{BO2} . For the current payment system offered by the Dairy Goat Cooperative of New Zealand, a progeny testing selection scheme generates the greatest increase in genetic gain per milking doe.

Keywords: selection schemes, dairy goats, progeny testing, pedigree selection, genetic gain, correlated responses.

INTRODUCTION

A comprehensive genetic improvement programme starts with the definition of the breeding goal for the production system (Harris et al. 1984). The breeding goal indicates the direction of a genetic improvement programme. For dairy goats the breeding goal can be defined in terms of profit per milking doe, profit per hectare or profit per kilogram of dry-matter intake. The goal informs the breeding objective which is a combination of breeding and economic values of important traits affecting profit (Grasser et al. 2006; Groen 2000; Harris et al. 1984; Lopez-Villalobos & Garrick 2005; Newman et al. 1992; Ponzoni 1986). For example, for New Zealand dairy goats, the breeding goal was defined as profit per milking doe, while the breeding objective was defined as a function of milk, fat, protein, lactose and liveweight (Solis-Ramirez et al. 2012). However, other functional traits, for example, somatic cell account and longevity need to be considered when defining a breeding objective for dairy goats.

The selection index equation was first described by Hazel (1943b) as:

$$I_Q = \sum_{i=1}^n b_i X_i$$

and the breeding objective or the aggregate genotype (T) for animal Q as:

$$T_Q = \sum_{j=1}^m a_j G_j$$

Where I_Q is an individual selection index value for animal Q , b 's are the partial regression coefficients weighting the phenotypic values (X 's) for each of the n traits in I, and the a 's are the economic values weighting the genetic values (G 's) for each of the m traits in T.

Selection indexes enable farmers to make optimal selection decisions, taking into account the relevant attributes of each animal to identify those that are most profitable for their particular commercial enterprise. Selection indexes may reflect the short term profit generated by a buck through the sale of his offspring or the longer term profit generated by his daughter's outcome in a self-replacing herd.

The traits in the breeding objective determine profit, but may not be the same as those traits that are recorded (selection criteria) and used to make selection decisions. The conventional approach to selection of breeding stock is to define an objective and then use knowledge of genetic and phenotypic (co)variances to choose the criteria for inclusion in the selection index (Goddard 1998).

Selection index theory uses genetic and phenotypic parameters to derive the trait weighting factors to maximise selection accuracy. The overall selection response and responses for each of the individual traits can be predicted (Van Vleck 1979; VanRaden 2004). This methodology has been used in many countries to improve dairy cattle (Nielsen et al. 2005; Philipson et al. 1994; Wilton & van Vleck 1968) and dairy sheep traits (Barillet 2007; Carta et al. 2009; Krupová et al. 2009; Legarra et al. 2007; Ramón et al. 2010; Wolfová et al. 2009a; Wolfová et al. 2009b). However, there is little information regarding the use of selection index theory for dairy goats. The estimation of economic values to construct a breeding objective has been published in some countries (Bett et al. 2007a; Bett et al. 2012b; Bett et al. 2012a; Lopes et al. 2012; Solis-Ramirez et al. 2012).

When selecting for a trait(s) in a population, selection responses are either direct if the trait is under selection or correlated if the trait is not under selection pressure (Falconer & Mackey 1996). A combination of the direct and correlated responses will influence the farm's total profit (Ponzoni 1986). The rate of genetic gain (ΔG) can be measured by generation or by unit of time and is affected by the genetic variance of the trait, number of available animals for selection, age at birth of progeny and by the accuracy of selection (Falconer & Mackey 1996; Rendel & Robertson 1950).

From a genetic point of view, progeny testing is the most accurate selection scheme to evaluate the genetic potential of a male. Progeny testing predicts an individual's breeding value following multiple matings of that individual to females and evaluation of the offspring. Progeny testing based on more than one offspring increases accuracy of selection, but increases generation interval. However, pedigree selection offers information that may be immediately available to assist with the selection of replacement does or bucks allowing selection decisions at an early age.

The objective of the present study was to evaluate different selection schemes and breeding objectives by predicting genetic gain in each objective and in individual traits

in the breeding objective that will improve profit per milking doe for New Zealand dairy goats.

MATERIALS AND METHODS

Herd structure

The herd structure assumed is presented in Table 9.1. A mating ratio of 1:22 for bucks:does, a litter size of 1.95 kids per doe and a replacement rate of 22% were assumed.

Table 9.1. Herd structure in the dairy goat herd.

	Age group (years)				
	0	1	...	10	total
No. animals	183	159	...	17	831
Percentage	22.02	19.13	...	2.01	100

Breeding objectives and selection schemes

Four scenarios were defined in Chapter 7: three scenarios according to the present and possible future situations for the New Zealand dairy goat industry and one for other countries where payment is based only on milk volume (Bett et al. 2007b; Montaldo et al. 2010). These four scenarios provided four different breeding objectives, which are described in terms of previously estimated economic values in Chapter 7 and breeding values (BVs) are:

1. Total milk-solids. Selecting for MS or the current breeding objective (T_{CBO}) is:

$$T_{CBO} = 11.64(BV_{FY}) + 12.27(BV_{PY}) + 12.39(BV_{LY}) - 2.15(BV_{LW}) + 0.04(BV_{LGTY}) - 8.22(BV_{SCS}) - 0.10(BV_{MY})$$

2. Fat and protein (1:2 ratio, respectively). Selection based on a proportion of 1FY and 2PY and a -\$0.04 penalty for MY. The ratio of 1:2 for fat and protein yield is a regular scenario found in the dairy industry due to the higher value for protein in the market place. Breeding objective one (T_{BO1}) is:

$$T_{BO1} = 14.49(BV_{FY}) + 31.08(BV_{PY}) - 0.76(BV_{LY}) - 2.15(BV_{LW}) + 0.04(BV_{LGT}) - 8.22(BV_{SCS}) - 0.14(BV_{MY})$$

3. Fat and protein (2:1 ratio, respectively). Selection based on a proportion of 2FY and 1PY and a -\$0.04 penalty for MY. The ratio of 2:1 for fat and protein yield in this scenario can be used to compare with the previous scenario to show a comparison of emphasis for fat rather than protein. Breeding objective two (T_{BO2}) is:

$$T_{BO2} = 28.93(BV_{FY}) + 14.36(BV_{PY}) - 0.76(BV_{LY}) - 2.15(BV_{LW}) + 0.04(BV_{LGT}) - 8.22(BV_{SCS}) - 0.14(BV_{MY})$$

4. Milk volume. Selecting for milk volume only (MY). In many countries, milk yield is the trait of primary importance because liquid milk is the primary product sold. Breeding objective three (T_{BO3}) is:

$$T_{BO3} = -1.45(BV_{FY}) - 0.85(BV_{PY}) - 0.76(BV_{LY}) - 2.15(BV_{LW}) + 0.04(BV_{LGT}) - 8.22(BV_{SCS}) + 1.43(BV_{MY})$$

In the four breeding objectives (T_{CBO} , T_{BO1} , T_{BO2} , and T_{BO3}), a payment of NZ\$13.00 per kg MS was used to calculate revenue per milk component. Milk-solids of 3.7%, 3.2%, 4.4% and 0.7% for fat, protein, lactose and minerals, respectively (Solis-Ramirez et al. 2011), were used to estimate the price per kilogram of fat and protein in T_{BO1} and T_{BO2} and the price per kilogram of milk in T_{BO3} . A \$0.04 cost per kilogram of milk for collecting, transporting and drying was imposed in T_{BO1} and T_{BO2} . For T_{CBO} there was no penalty for MY, while in T_{BO3} , MY was the selected trait.

There are many possible selection schemes that might be applied to enable genetic improvement of an animal population. Two selection schemes were chosen to reflect the current situation in the New Zealand dairy goat industry and a third to reflect a future opportunity. The selection schemes were:

- 1) Pedigree selection using one lactation record (PS1) per dam;
- 2) Pedigree selection using an average of three lactations per dam (PS3); and
- 3) Progeny test (PT).

A representation of the pedigree and progeny test selection schemes are presented in Figures 9.1 and 9.2. The traits in the selection index associated with each breeding objective and selection scheme are described in Table 9.2.

Genetic and phenotypic parameters and bending process

Heritabilities, repeatabilities, genetic and phenotypic correlations and (co) variances for the traits in the breeding objective and selection indexes were obtained from Chapter 8 and from literature results for dairy goats, dairy cattle or sheep. The matrix of genetic and phenotypic correlations was subjected to a bending process to ensure it was positive definite (Hayes & Hill 1981; Jorjani et al. 2003). The genetic and phenotypic parameters used are presented in Table 9.3, while the genetic and phenotypic (co) variances before and after the bending process are presented in Appendix 9.2.

Table 9.2. Selection index, breeding objectives and selection schemes in New Zealand dairy goats.

Traits in the selection index	Breeding objective	Selection scheme	
		Pedigree selection/number of records.	Progeny test/number of offspring
MS	T _{CBO}	1 3	8.
FY+PY-MY	T _{BO1}	1 3	8
FY+PY-MY	T _{BO2}	1 3	8
MY	T _{BO3}	1 3	8

Selection Index

Four scenarios were defined in Chapter 7: three scenarios according to the present and possible future situations for the New Zealand dairy goat industry and one for other countries where payment is based only on milk volume (Bett et al. 2007b; Montaldo et al. 2010). The selection index was developed based on either one or three traits according to the payment system and breeding objective, while the breeding objective consisted of seven traits.

Three selection indexes were used for the four breeding objectives, which described in terms of traits and weighting factors b are:

- 1) Milk-solids index: Selection is based on an index using total milk-solids as a unique trait.

$$I_Q = b_{MS}MS$$

- 2) Fat, protein and milk yield index.

$$I_Q = b_{FY}FY + b_{PY}PY + b_{MY}MY$$

- 3) Milk yield index. Selection was based milk yield only.

$$I_Q = b_{MY}MY$$

where, I_Q is the selection index, b 's are regression coefficients for the indicated trait and abbreviation for traits was described previously.

The setting up of the general matrix procedure following selection index theory for three traits in the selection index and seven traits in the breeding objective was:

$$= \begin{bmatrix} K\sigma_{G_{MY}}^2 & K\sigma_{G_{MY,FY}} & K\sigma_{G_{MY,PY}} & K\sigma_{G_{MY,LW}} & K\sigma_{G_{MY,LGTY}} & K\sigma_{G_{MY,SCS}} \\ K\sigma_{G_{FY,MY}} & K\sigma_{G_{FY}}^2 & K\sigma_{G_{FY,PY}} & K\sigma_{G_{FY,LW}} & K\sigma_{G_{FY,LGTY}} & K\sigma_{G_{FY,SCS}} \\ K\sigma_{G_{PY,MY}} & K\sigma_{G_{PY,FY}} & K\sigma_{G_{PY}}^2 & K\sigma_{G_{PY,LW}} & K\sigma_{G_{PY,LGTY}} & K\sigma_{G_{PY,SCS}} \end{bmatrix} \begin{bmatrix} b_{MY} \\ b_{FY} \\ b_{PY} \end{bmatrix}$$

which in matrix notation can be re-written as:

$$\mathbf{Pb} = \mathbf{Ga}$$

where:

\mathbf{P} = phenotypic (co)variance values matrix for the traits (MY=milk yield, FY=fat yield and PY=protein yield) in the selection criteria;

\mathbf{G} = the genetic (co)variance matrix for the m -traits in the breeding objective;

\mathbf{b} = unknown vector of partial regression coefficients for each of the n -traits in the selection criteria;

\mathbf{a} = the vector of economic values for the traits in the breeding objective;

$K=1/2$ (weighting factor for genetic variances and covariances); and

k_i, k_{ij}, k_{ji} = weighting factor for phenotypic variances of a trait i (k_i) and covariances between traits i and j (k_{ij}, k_{ji}) according with particular selection scheme.

Weighting factor k was calculated according to the selection scheme. The equations to calculate this coefficient are presented in Table 9.4. The weighting factors were estimated for one (PS1) and three (PS3) records or progeny test. Does for PS3 may have from 3 to 10 lactation records.

The solution for the partial regression coefficients (weighting factors) was:

$$\mathbf{b} = \mathbf{P}^{-1}\mathbf{G}\mathbf{a}$$

where:

\mathbf{P}^{-1} = the inverse matrix of P ; and

\mathbf{G}, \mathbf{b} and \mathbf{a} were defined earlier.

The accuracy of the index (r_{IT}) was estimated as the correlation between the selection index and the breeding objective:

$$r_{TI} = \frac{\sqrt{\mathbf{b}'\mathbf{P}\mathbf{b}}}{\sqrt{\mathbf{a}'\mathbf{C}\mathbf{a}}}$$

where:

\mathbf{b}' = the transpose vector of regression coefficients;

\mathbf{a}' = the transpose vector of EVs for the traits in the breeding objective; and

\mathbf{C} = the genetic (co)variances matrix of traits in the breeding objective;

\mathbf{P} = it was defined earlier.

Table 9.3. Heritabilities, repeatabilities, genetic and phenotypic correlations for the traits in the breeding objective and selection index.

Genetic and phenotypic parameters ¹							
Trait ²	MY	FY	PY	LY	LW	LGTY	SCS
MY	0.21 (0.40)	0.890	0.932	0.795	0.250	0.410	-0.210
FY	0.725	0.22 (0.41)	0.856	0.555	0.250	0.710	-0.240
PY	0.812	0.822	0.23 (0.39)	0.647	0.320	0.750	-0.180
LY	0.787	0.332	0.425	0.23 (0.37)	0.180	0.730	-0.290
LW	0.364	0.385	0.467	0.342	0.58 (0.80)	-0.300	0.240
LGTY	0.756	0.389	0.398	0.394	-0.039	0.10 (0.15)	-0.080
SCS	-0.107	-0.117	0.024	-0.045	0.240	-0.439	0.20 (0.53)

¹Phenotypic correlations above diagonal; genetic correlations below the diagonal; heritabilities on the diagonal and repeatabilities in brackets. ²MY is milk yield, FY is fat yield, PY is protein yield, LY is lactose yield, LW is liveweight, LGTY is longevity and SCS is somatic cell score.

Table 9.4. Values or equations to estimate the weighting factors k_i for phenotypic variance or k_{ij} for phenotypic covariances according to selection scheme.

Selection scheme	Weighting factor k for:	
	Phenotypic Variance	Phenotypic covariance
PS1	1	1
PS3	$\left[\frac{1 + (N - 1)t}{N} \right] \text{var}_{P_i}$	$\left[\frac{\sigma_{P_{ij}} + (N - 1)t}{N} \right] \sigma_{G_{ij}}$
Progeny testing	$\left[\frac{1 + (B - 1)1/4h^2}{B} \right] \text{var}_{P_i}$	$\left[\frac{\sigma_{P_{ij}} + (B - 1)1/4h^2}{B} \right] \sigma_{P_{ij}}$

N=Number of records, t=repeatability, B=number of progeny per buck, h^2 =heritability, var =phenotypic (p_i) or genetic variance; $\sigma_{G_{ij}}, \sigma_{P_{ij}}$ = genetic and phenotypic covariance between traits i and j , respectively. PS1 is pedigree selection using one lactation, PS3 is Pedigree selection using 3 lactations.

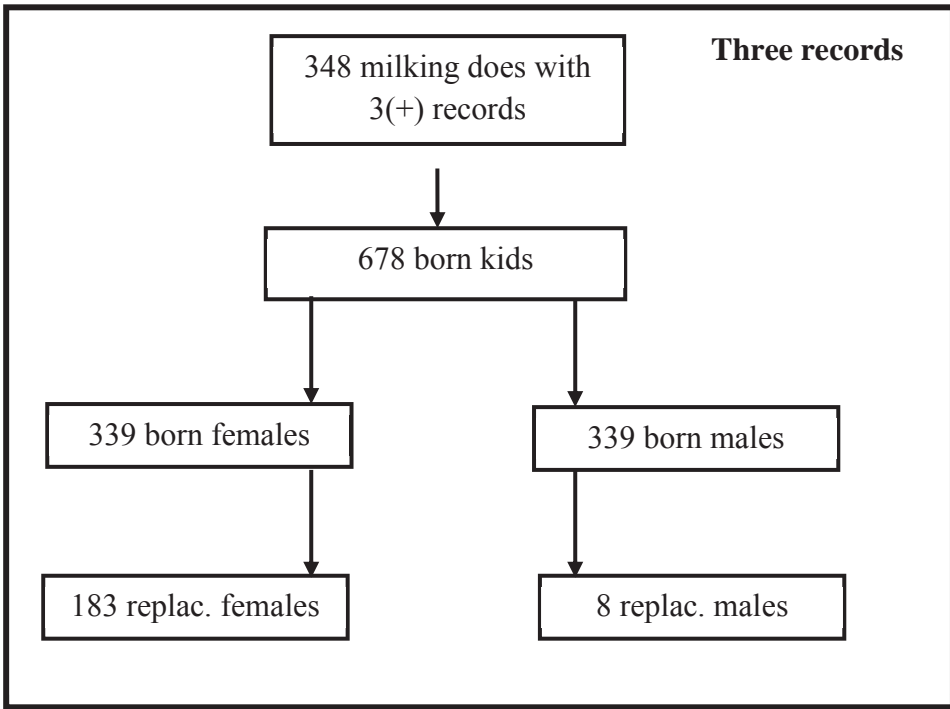
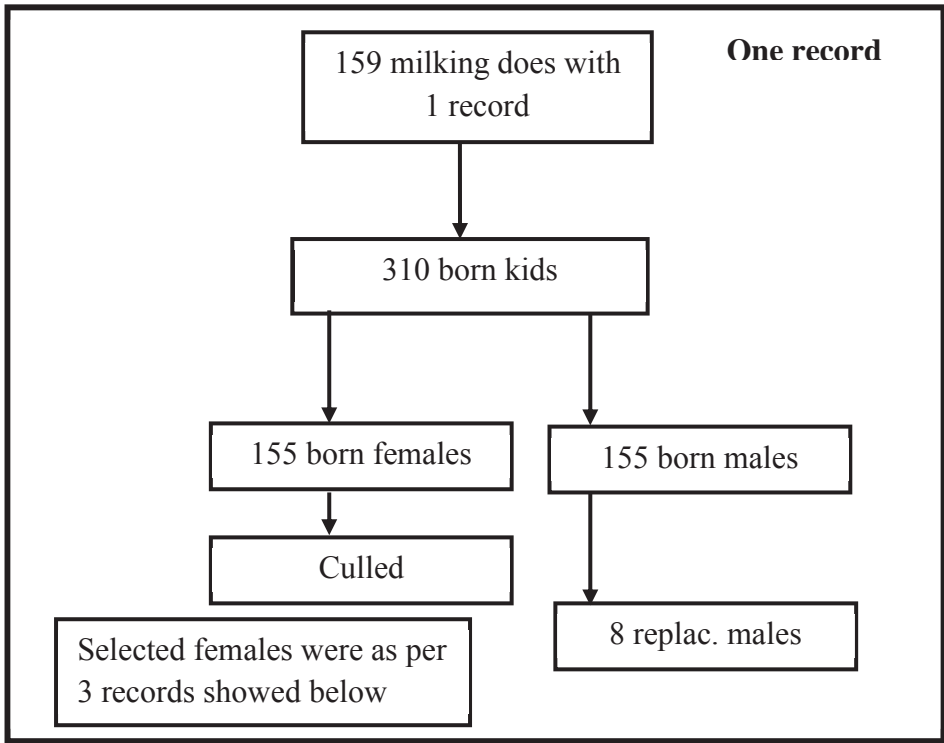

Figure 9.1. Diagram for pedigree selection using one or three dam lactations to select replacement females or males in a dairy goat herd.

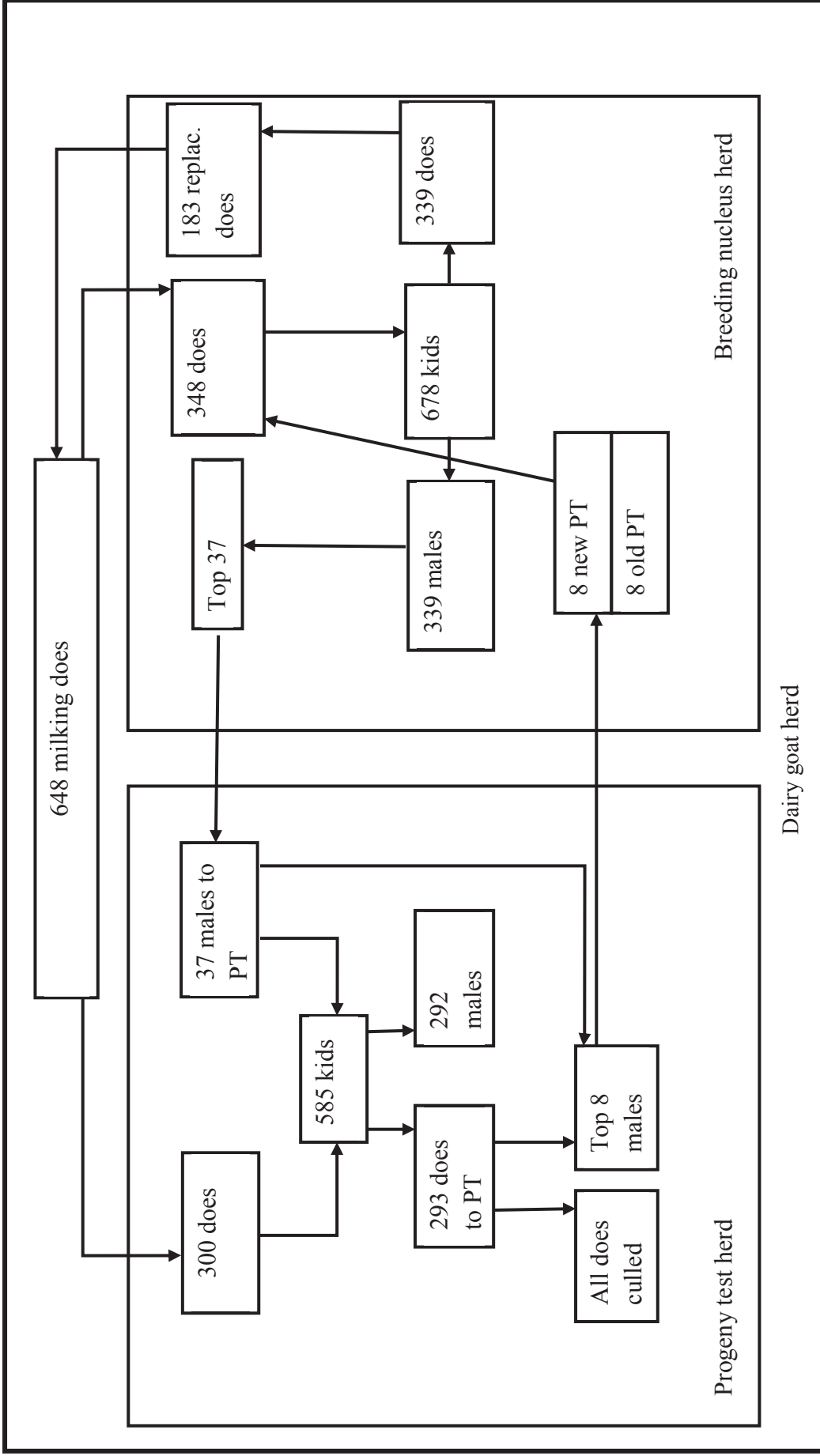

Figure 9.2. Progeny testing scheme (PT) within a New Zealand dairy goat herd.

Genetic gain

First selection stage

The genetic gain per unit of time in the breeding objective (ΔG_T) was calculated as (Rendel and Robertson, 1950):

$$\Delta G_{T/t} = \frac{r_{TI}\sigma_T i}{L}$$

where:

r_{TI} = accuracy of selection;

L = generation interval;

σ_T = standard deviation of T;

i = standardized selection differential; and

t = unit of time (years).

Selection accuracy was estimated as the correlation between the selection index and the breeding objective using one and three records for pedigree selection, and one record to select males and females in progeny test.

Genetic superiority was calculated for males (G_m), for females (G_f) and then a combined single value for both the genetic superiority and generation interval (L_m and L_f for males and females, respectively) to estimate the genetic gain (ΔG) as,

$$\Delta G_{T/t} = \frac{G_m + G_f}{L_m + L_f}$$

Second selection stage

A second selection stage is required when a progeny test is implemented as a selection scheme. The first stage is the selection of rams to be progeny tested based on pedigree information, while a second stage is the selection of the best progeny tested or proven

(Blair 1989). The number of sires to test (K) and its proportion (P), and the number of offspring per buck (n) were estimated according to Robertson (1957) as:

$$K = \frac{N}{S}, \quad n = 0.56 \sqrt{\frac{K}{h_1^2}}, \quad \text{and} \quad P = \frac{S}{\left(\frac{N}{n}\right)}$$

where:

N = number of does to mate;

S = number of sires required, and

h_1^2 = heritability of the selection index.

Genetic gain for this stage was calculated using the earlier equation mentioned on rate of genetic gain for the first stage, but considering the values of K, P and n to get the final numbers of bucks available for testing and intensity of selection.

Selection accuracy was calculated as described in first stage of selection but using eight offspring per sire in the weighting factor. The equation to calculate the genetic gain considering the first and second selection stages in males was described as:

$$\Delta G_{T/t} = \frac{(G_m + G_f)}{(L_m + L_f)} + \frac{G_{2m}}{L_{2m}}$$

where:

G_m = genetic superiority after the first stage of selection for males;

G_f = genetic superiority after the first stage of selection for females (there is no second stage of selection for females);

G_{2m} = genetic superiority after the second stage of selection for males;

L_m = generation interval for males for first stage of selection;

L_f = generation interval for females;

L_{2m} = generation interval in males for second stage of selection;

The genetic responses per year in each trait i in the breeding objective ($CR_{i/t}$) were estimated as:

$$CR_{i/t} = \frac{\mathbf{b}'\mathbf{G}/\sqrt{\mathbf{b}'\mathbf{P}\mathbf{b}}}{L}$$

where all terms were already defined.

RESULTS

Selection events, the number of animals available for selection, animals selected, accuracy of selection, generation interval and genetic gain for all studied breeding objectives and selection schemes are presented in Table 9.5. For pedigree selection only one selection stage was applied for males and females, while for progeny testing, two stages of selection were applied. Intensity of selection values were a reflection of the percentage of selected replacements, which mostly change across selection schemes within each breeding objective in males. A similar number of females available for selection in the progeny test herd and the number of does with three or more records resulted in similar selection intensity in the first stage of selection.

Generation interval was 4.3 years on average for all selection schemes for females. Generation interval for PS1 females were also 4.3 years because replacement does were taken from 3+ year old milking does due to lack of one records milking does to get the 183 required does replacements for PS1 scheme. For males the generation interval was 2 years in pedigree selection and 3 years in progeny test. Generation interval remained similar across all selection schemes for females. In males, it was assumed to be of two and three years for pedigree selection and progeny testing scheme, respectively since the males are chosen after one lactation. Selection accuracy and genetic standard

deviation varied between selection schemes due to changes in number of records in the selection scheme and different values of the weighting factors.

The genetic gain was higher in the breeding objectives involving milk-solid traits (T_{CBO} , T_{BO1} , and T_{BO2}) for the PT scheme than for the two pedigree selection schemes. Within objective, PS3 gave greater genetic gain than PS1. Annual genetic gain per doe in the PS3 scheme exceeded the gain in PS1 by \$0.31-\$0.33, while the PT scheme exceeded the gain in PS1 by \$0.56-\$0.63, and PT exceeded the gain in PS3 by \$0.25-\$0.31.

In the T_{BO3} objective involving only milk yield, the highest genetic gain was for the PT selection scheme followed by PS3 and then PS1. The differences in the annual genetic gain per doe per year were \$1.95, \$2.97 and \$1.02 for PS3 over PS1, PT over PS1 and PT over PS3, respectively.

Within the same breeding objective the genetic gain for the PS3 scheme exceeded PS1 by 36.26%, 43.10%, 40.5% and 43.10% in T_{CBO} , T_{BO1} , T_{BO2} and T_{BO3} , respectively. The comparison between PT and PS1 showed greater benefits between selection schemes, ranging from 63.74% in the T_{CBO} to 79.75% in T_{BO1} . While comparing PS3 with PT changes ranged from 17.14% in the T_{BO3} to 27.92% in the T_{BO2} . This means that choosing animals with three lactations to select replacement animals from a PS3 is worth an extra 3.26-48.75% on genetic gain, and changing from PS1 information to PT is worth an extra 63.74-79.75% of genetic gain; while changing from PS3 to PT adds extra 17.14-27.92%% to genetic gain.

Genetic responses for traits in the breeding objectives are presented in Table 9.6. Differences between responses in the traits of the same breeding objective and different selection schemes are presented in Appendix 9.1.

The genetic responses within the same breeding objective for different selection schemes were higher for all traits in the PT scheme for T_{CBO} and T_{BO3} , but only for FY, PY, LWT, SCS and MS traits in T_{BO1} and T_{BO2} . While positive genetic gains of productive traits in T_{BO1} and T_{BO2} were observed, a positive increase in SCS also was observed. Genetic responses in PS3 for MY, LY and LGTY were higher in T_{BO1} and T_{BO2} followed by PT and PS1. All the differences in genetic response between PS3 and PS1, PT and PS1, and between PT and PS3 for all traits are presented in Appendix 9.1.

In general, trait genetic gains increase from PS1 to PS3 to PT, except MY, LY and LGTY decrease from PS3 to PT; while SCS increases from PS3 to PT. Furthermore, genetic responses in traits in the breeding objective change gradually from PS1 to PS3 to PT, except LW and LGTY in T_{CBO} and LGTY in both T_{BO1} and T_{BO2} .

Table 9.5. Genetic gain for three selection schemes and four breeding objectives in New Zealand dairy goats.

Selection event	Item	Breeding objectives and selection schemes ¹															
		T _{CBO}				T _{BO1}				T _{BO2}				T _{BO3}			
		PS1	PS3	PT	PT	PS1	PS3	PT	PT	PS1	PS3	PT	PT	PS1	PS3	PT	PT
Selection of female replacements	No. females available	339	339	339	339	339	339	339	339	339	339	339	339	339	339	339	339
	No. Females selected	183	183	183	183	183	183	183	183	183	183	183	183	183	183	183	183
	% selected	54	54	54	54	54	54	54	54	54	54	54	54	54	54	54	54
	Intensity of selection	0.74	0.74	0.74	0.74	0.74	0.74	0.74	0.74	0.74	0.74	0.74	0.74	0.74	0.74	0.74	0.74
First selection of male replacement	No. males available	159	339	339	339	159	339	339	339	159	339	339	339	159	339	339	339
	No. Males selected	8	8	37	37	8	8	37	37	8	8	37	37	8	8	37	37
	% selected	5.03	2.40	11	11	5.03	2.40	11.00	11.00	5.03	2.40	11.00	11.00	5.03	2.40	11.00	11.00
	Intensity of selection	2.04	2.36	1.71	1.71	2.04	2.36	1.71	1.71	2.04	2.36	1.71	1.71	2.04	2.36	1.71	1.71
Second selection of male replacement	No. males available			37	37			37	37			37	37			37	37
	No. Males selected			8	8			8	8			8	8			8	8
	% selected			19	19			19	19			19	19			19	19
	Intensity of selection			1.43	1.43			1.43	1.43			1.43	1.43			1.43	1.43
Selection accuracy (rTI)	Females	0.32	0.32	0.24	0.24	0.33	0.33	0.24	0.24	0.32	0.32	0.24	0.24	0.30	0.33	0.24	0.24
	Males first selection	0.24	0.32	0.24	0.24	0.23	0.33	0.24	0.24	0.23	0.32	0.24	0.24	0.23	0.33	0.24	0.24
	Males second selection			0.56	0.56			0.62	0.62			0.62	0.62			0.56	0.56
Genetic std deviation		7.85	7.85	7.85	7.85	6.36	6.36	6.36	6.36	7.05	7.05	7.05	7.05	36.66	36.66	36.66	36.66
	Females	1.86	1.86	1.38	1.38	1.56	1.55	1.12	1.12	1.65	1.67	1.24	1.24	8.02	8.95	6.51	6.51
	Males first selection	3.84	5.93	3.22	3.22	2.98	4.95	2.61	2.61	3.31	5.32	2.89	2.89	17.20	28.55	15.04	15.04
Generation interval	Males second selection			6.29	6.29			5.64	5.64			6.25	6.25			29.36	29.36
	Females	4.3	4.3	4.3	4.3	4.32	4.3	4.3	4.3	4.3	4.3	4.3	4.3	4.3	4.3	4.3	4.3
	Males	2	2	3	3	2	2	3	3	2	2	3	3	2	2	3	3
Genetic gain		0.91	1.24	1.49	1.49	0.72	1.03	1.28	1.28	0.79	1.11	1.42	1.42	4.00	5.95	6.97	6.97

¹PS1, PS3 and PT are the selection schemes and T_{CBO}, T_{BO1}, T_{BO2}, and T_{BO3} are the breeding objectives previously explained.

Table 9.6. Genetic responses in traits in the breeding objective of the three selection schemes and four breeding objectives in New Zealand dairy goats.

Breeding objective	Selection scheme	Selection index	Genetic response in trait:									
			MY	FY	PY	LY	LW	LGTY	SCS			
T _{CSO}	PS1	MS	1.178	0.090	0.073	0.138	0.050	0.002	-0.001			
	PS3		1.574	0.121	0.098	0.185	0.067	0.003	-0.001			
	PT		2.433	0.186	0.143	0.271	0.256	0.564	-0.004			
T _{BO1}	PS1	FY+PY+MY	1.150	0.110	0.086	0.068	0.134	0.323	-0.002			
	PS3		1.915	0.143	0.134	0.133	0.207	0.589	-0.001			
	PT		1.409	0.226	0.185	0.004	0.299	-0.009	0.004			
T _{BO2}	PS1	FY+PY+MY	0.859	0.115	0.073	0.034	0.116	0.191	-0.003			
	PS3		1.686	0.149	0.122	0.106	0.190	0.493	-0.002			
	PT		1.267	0.239	0.168	-0.011	0.273	-0.024	0.000			
T _{BO3}	PS1	MY	1.333	0.080	0.071	0.113	0.107	0.522	-0.003			
	PS3		1.721	0.103	0.092	0.146	0.138	0.674	-0.004			
	PT		2.783	0.166	0.148	0.236	0.222	1.089	-0.006			

DISCUSSION

Genetic gain in the objectives

Genetic gain per unit of time available is affected by several factors: the genetic variance in the population; the number of animals for selection, the number of animals selected; the average age of parents at birth of their progeny and by the accuracy of selection (Blair 1989; Falconer & Mackey 1996; Rendel & Robertson 1950; Robertson 1957). Changes in any of these factors will affect the rate of genetic gain in the population. In this study three selection schemes were devised to predict the rate of genetic gain in several breeding objectives and the contributing traits. There are many different potential selection schemes and the above mentioned factors that dictate the rate of genetic gain can also be varied. Additional research is required to define the optimal selection scheme for dairy goats in New Zealand.

Breeding strategies are evaluated according to their rate of response, rate of inbreeding and size of the herd (Gibson & Jeyaruban 1993). Rate of response and rate of inbreeding determine the technical success of the breeding programme, while size of herd is a principal determinant of cost. The aim of the present study was to evaluate alternative selection schemes and breeding objectives for New Zealand dairy goat herds by estimating the genetic gain and correlated responses for different traits affecting profit per milking doe per year.

The T_{CBO} is the current scenario that the DGC apply to dairy goat farmers based on a payment system per kg of milk-solids. T_{BO1} and T_{BO2} are alternative scenarios for FY and PY, but penalising milk volume (MY), while T_{BO3} is a payment system based on MY payment applied in some countries where milk yield volume is still the main trait (Bett et al. 2009b; Bett et al. 2012b; González-Peña et al. 2012; Montaldo et al. 2010). The extent to which the choice of a selection index or criteria accurately reflects the biological and economical efficiency of the New Zealand dairy goat herd depends on the phenotypic and genetic parameters used in the prediction of genetic gains. The gains are more accurately predicted if all these parameters are well known from the population under selection. When the genetic parameters are not estimated from the population under study the predicted genetic gain may be biased (up or down). This study used a mix of phenotypic and genetic parameter estimates from the New Zealand

dairy goat population and from published data from different goat, cattle and sheep populations in various countries because such estimates were not available for New Zealand dairy goat herds.

Within breeding objectives, PT generally had the higher genetic gain followed by PS3 and PS1. The magnitude of the genetic gain in pedigree selection and for PT agree with the increase of accuracy of selection and the use of more information in the selection scheme (Falconer & Mackey 1996; Rendel & Robertson 1950). Pedigree selection using an average of three lactations on dam had selection accuracy greater than when pedigree selection was based on one lactation; while, the selection accuracy of PT was higher due to the evaluation of eight daughters per buck. Selection accuracy of PS3 is expected to be underestimated since the herd structure to take replacements was based on 3 plus lactations but 3 was used as the base to calculate accuracy in the selection index. The weighting factors for the selection indexes showed in Table 9.4 are the key aspects to estimate the selection accuracy for the three selection schemes. It is expected that the number of records and number of progeny per buck are the key aspects to increase or reduce the accuracy of the selection scheme.

From a practical point of view the implementation of pedigree selection is less complex and cheaper than using PT. The cost of PT is higher than pedigree selection due to the greater number of animals being recorded and the number of males being tested before culling.

Progeny testing helps dairy goat farmers to identify the genetically best bucks and can be run within herd or across herds, providing there are genetic links between herds. For example running in a national progeny testing scheme across herds using artificial insemination (AI) will increase the population size and therefore the number of animals available for selection. This makes it possible to apply a greater selection intensity (because of AI) and to get a higher genetic gain. However, the scheme requires a higher organisational level in order to define a unique breeding objective and common husbandry practices to reduce costs of selection. The costs of the progeny test must be considered as an extra cost in the production system for recording and running extra animals. This should be offset against the additional revenue from increased genetic gain.

Three out of the four breeding objectives (T_{CBO} , T_{BO1} , and T_{BO2}) aim to breed for improved milk-solids but with different economic weightings to the components. It is unsurprising that the overall genetic gain in these breeding objectives is similar. T_{BO3} was the simplest breeding objective as there was no negative weightings for any milk components, resulting in an apparently higher genetic gain. Due to nonnegative weighting for any of the traits in the breeding objective with all positive correlations working to increase milk yield in this scenario.

Genetic gain in traits

The concomitant genetic changes in traits across breeding objectives and selection schemes is a reflection of the magnitude and direction of heritability and genetic correlation estimates (Falconer & Mackey 1996). Greater values were observed in progeny testing than in pedigree selection due to higher accuracy and sources of information. Using appropriate traits and weightings to control changes in the correct direction is important to increase profit (James 1982). Revenue comes differentially from the various traits due to genetic relationships and their economic importance.

Genetic responses in individual traits were greater in PT than in any other selection scheme; except for MY, LY, LGTY and SCS in T_{BO1} and T_{BO2} . Individual trait responses were higher for PS3 than when using PS1.

The rate of genetic gain in MY was reduced as a consequence of penalising MY by \$0.04 per litre of milk volume. Additionally, the genetic gain in LY was greater when using PS3 relative to PT for T_{BO1} and T_{BO2} because of the genetic gain in MY being less under PT versus PS3. These changes in MY and LY traits are driven by the genetic correlation between them. In dairy cattle, the MY-LY genetic correlation is usually higher than 0.95 (Miglior et al. 2007; Welper & Freeman 1992), which indicates that genetic changes in LY will be strongly linked to any changes in MY. In dairy goats, a small number of studies suggested that this genetic correlation ranged from 0.82 (Montaldo et al. 2010) to 0.98 (Lopes et al. 2012), resulting in an average value that is lower than those reported for dairy cattle. Applying bending to achieve a positive definite G matrix resulted in an even lower MY-PY genetic correlation for use in the selection index. Therefore, it is likely that the genetic changes in traits correlated to LY

are underestimated in this study. It is important that industry data are collected to enable the estimation of more robust genetic correlations with LY.

The positive correlations between traits with milk volume make it possible to increase all traits. However, a strong increase in milk volume means a strong increase in water content, which is not favourable for the industry, due to increased transport, facilities and drying costs. However for countries where MY is the most important economic trait due to liquid milk for human consumption, high genetic gain in the short term can be achieved due to the significant genetic variation in MY.

Larger animals tend to demand more energy than small animals to cover their requirements for maintenance and production. Larger animals can be desirable when price per kg of LW is sufficiently high in the market. In the absence of high LW value, increases in LW incurs more maintenance and LW gain expenses with minimal meat return, thereby reducing profit per animal. A lower increase of LW in T_{CBO} allowed for improved revenue due to a reduction in maintenance and LW gain cost while keeping the highest MS production.

The breeding objectives with the lowest increases in SCS and highest LGTY increases were T_{CBO} and T_{BO3}, except PS1 and PS3 in T_{CBO} resulting in healthier and longer productive life does. Healthy animals require less veterinary costs, while increasing LGTY means an increase in productive life time and a reduction in the number of replacement animals per year, saving important economic resources and increasing profit per animal. Reduction in LY is due to negative weight for MY and positive correlations of MY and LY. Reduction in SCS was associated to increases in MY in T_{CBO} and T_{BO3}, while T_{BO1} and T_{BO2} remain with similar low SCS values. Genetic and phenotypic correlations between LW and LGTY are negative, therefore increases in LW in T_{BO1} and T_{BO2} caused an reduction in LGTY. Increasing LGTY had been recommended in goats (Bett et al. 2011) and in dairy cattle (Harris 1989a, b; LopezVillalobos 1998).

Reduction of SCS also means an increase in revenue by healthier animals and lower penalties for high SCC values. SCS showed no change as a consequence of increasing from PS1 to PS3, but an increase occurred from PS1 or PS3 to PT scheme. The impact of SCS on revenue has been reported for goats (Bett et al. 2012a), sheep (Legarra et al.

2007) and dairy cattle (Charfeddine et al. 1997; Harris & Freeman 1993; Sadeghi-Sefidmazgi et al. 2011).

CONCLUSIONS

The PT had the highest genetic gain in the objectives and in most of individual traits, followed by PS3 and then PS1. Milk yield increased in all breeding objectives, but greater increase was observed in T_{BO3} . Milk components all increased except LY in both T_{BO1} and T_{BO2} . Liveweight increased in all breeding objectives, but higher increases were observed in T_{BO1} and T_{BO2} . The highest increase in total milk-solids was in T_{CBO} followed by T_{BO3} , but T_{BO1} and T_{BO2} were similar.

Longevity increased in both T_{CBO} and T_{BO3} , but a decrease was observed from PS3 to PT after an increase from PS1 to PS3 in T_{BO1} and T_{BO2} . SCS decreased in breeding objectives T_{CBO} and T_{BO3} , but increased in T_{BO1} and T_{BO2} .

According to the current market scenario for the DGC, the T_{CBO} under a progeny testing scheme should provide the greatest genetic gain in the objective and in individual traits per milking doe focused to produce milk powder for exporting.

APPENDICES TO CHAPTER 9

Appendix 9.1. Differences in genetic responses between selection schemes for the four breeding objectives in New Zealand dairy goats.

Breeding objective	Difference between selection schemes ¹	Genetic response in trait:							
		MY	FY	PY	LY	LW	LGTY	SCS	
T _{CBO}	PS3-PS1	0.396	0.030	0.025	0.046	0.017	0.001	0.001	
	PT-PS1	1.255	0.096	0.070	0.133	0.205	0.561	-0.004	
	PT-PS3	0.858	0.066	0.046	0.086	0.188	0.560	-0.003	
T _{BO1}	PS3-PS1	1.150	0.110	0.086	0.068	0.134	0.323	-0.002	
	PT-PS1	1.915	0.143	0.134	0.133	0.207	0.589	-0.001	
	PT-PS3	-0.507	0.082	0.051	-0.129	0.092	-0.598	0.005	
T _{BO2}	PS3-PS1	0.826	0.034	0.049	0.073	0.074	0.302	0.001	
	PT-PS1	0.408	0.124	0.095	-0.045	0.157	-0.215	0.003	
	PT-PS3	-0.418	0.090	0.046	-0.117	0.083	-0.517	0.003	
T _{BO3}	PS3-PS1	0.388	0.023	0.021	0.033	0.031	0.152	-0.001	
	PT-PS1	1.450	0.087	0.077	0.123	0.116	0.567	-0.003	
	PT-PS3	1.062	0.063	0.057	0.090	0.085	0.415	-0.002	

¹PS3 = Pedigree selection using average of three records on dam, PS1 = Pedigree selection using one record on dam, PT = Progeny test.

Appendix 9.2. Genetic and phenotypic covariances of the traits in the breeding objective before and after bending.

Genetic and phenotypic covariances before bending process ¹									
Trait	MY	FY	PY	LY	LWT	LGTY	SCS		
MY	7111.100(27800)	907.018	780.388	1093.994	170.035	34.180	-15.262		
FY	175.389	8.220(37.36)	26.275	29.717	6.233	2.169	-0.639		
PY	164.743	5.674	5.792(25.22)	28.463	6.555	1.883	-0.394		
LY	262.094	4.014	4.3117	17.744(76.74)	6.4322	3.197	-1.107		
LWT	95.272	3.428	3.490	4.474	9.651(16.64)	-0.612	0.427		
LGTY	10.081	0.176	0.151	0.262	-0.0191	0.025(0.25)	-0.0174		
SCS	-1.756	-0.065	0.0112	-0.037	0.145	-0.0135	0.038(0.19)		
Genetic and phenotypic covariances after bending process ¹									
Trait	MY	FY	PY	LY	LW	LGTY	SCS		
MY	1344(6400)	457.887	374.437	558.907	211.500	1968.000	-28.392		
FY	80.225	9.1(41.36)	27.646	31.267	17.002	273.961	-2.608		
PY	71.621	5.969	5.79(25.22)	28.463	16.994	225.988	-1.528		
LY	121.586	4.224	4.312	17.74(76.74)	16.675	383.694	-4.293		
LW	107.375	9.350	9.049	4.474	64.86(111.83)	-190.350	0.427		
LGTY	525.911	22.271	18.163	31.486	-5.927	360(3600)	-8.112		
SCS	-2.959	-0.266	0.043	-0.142	1.460	-6.301	0.57(2.86)		

¹phenotypic covariances above diagonal; genetic covariances below the diagonal; genetic variances on the diagonal and phenotypic variance in brackets.

CHAPTER 10
GENERAL DISCUSSION

INTRODUCTION

The world dairy goat industry shows wide variation in production systems between countries. In some countries the use of modern husbandry and animal evaluation technologies is common and production is based mainly on highly specialised animals (Azis 2010; Devendra 2013; Lindsay & Skerrit 2003). In other countries traditional production systems have minimal use of modern technology and farm low production dual-purpose or native animals. In the New Zealand dairy goat industry the number of herds, herd size, and production of milk solids are all increasing to supply a growing demand for goat milk powder and particularly infant and toddler formula in Australia, Europe, Asia, and Middle East. This product demand is a business opportunity to grow the production system, increase income to farmers and New Zealand and to increase competitiveness of the New Zealand dairy goat industry in preparation for eventual challenges from other countries or industries in the future. Developing a national genetic improvement scheme for New Zealand dairy goats, should facilitate the breeding of high genetic merit animals in the national herd. This genetic improvement will enable the dairy goat industry to better meet product demand in the medium and longer term, thereby improving farmer profit.

The goal of the current research project was to boost the New Zealand dairy industry by developing a genetic improvement programme for dairy goats. Specific objectives were to: describe dairy goat production systems; evaluate mathematical models to predict lactation yields; describe lactation trait curves in population and different breed groups and parities; estimate economic values and genetic parameters and to evaluate selection schemes for different breeding objectives.

MAIN POINTS FROM THIS STUDY

A survey was undertaken to describe relevant aspects of New Zealand dairy goat production systems. Dairy goat farmers provide milk to the Dairy Goat Cooperative to be processed into milk powder for exporting. Feed is transported to the goats housed in covered yards. This survey and previous studies (Morris et al. 1997; Morris et al. 2006; Morris et al. 2011; Solis-Ramirez et al. 2011) showed that the average size of New Zealand dairy goat herds has increased from about 300 to 650 milking does over the last

two decades with a high dependence on the Saanen breed (Morris et al. 1997; Solis-Ramirez et al. 2011). The information collected in this survey was used to prepare a bio-economic farm model to enable the calculation of economic values for traits contributing to farm revenue. The model avoided double-counting through having independent modules to estimate changes in traits. For the current payment system the EVs were (in NZ\$) 11.64, 12.27, 12.39, -2.15, 0.04, -8.22 and -0.10 for fat yield (FY), protein yield (PY), lactose yield (LY), liveweight (LW), longevity (LGTY), somatic cell score (SCS) and milk yield (MY), respectively. The EVs were more sensitive to changes in milk component revenue than in feed cost, but mostly they were fairly stable.

There were no studies demonstrating the best methodology to transform test day records into lactation yields for New Zealand dairy goats. Four mathematical functions using random regression models to predict milk production traits were examined. Four fit statistics were used to test the goodness of fit of predicted curves to the raw data. Based on AIC value differences among models from the best model, the models were ranked. Legendre and Wilmink models were similar, but further overview of other fit statistics and the fact that the dairy goats are under indoor conditions help to chose the Wilmink model as the best model function to predict lactation yields. Lactation yields were estimated for ten breed groups and five parities. Some crossbred groups typically had higher production levels than purebreeds. The highest lactation yields were from 3/4 Saanen-1/4 Other breeds or Toggenburg and lowest for Toggenburg. The third lactation yielded the highest levels of milk, fat and protein, while the first lactation yielded the lowest values.

Moderate heritability and repeatability values were estimated for MY, FY, PY and SCS, which suggested reasonable genetic progress could be achieved through selection for these traits. Estimated genetic correlations between milk traits and SCS suggested milk traits could be improved without an undesirable increase in SCS.

Comparison of two pedigree-based selection plans with a within-herd progeny test demonstrated that the progeny test provided the greatest genetic gain in the selection objective. Based on the present payment system for the Dairy Goat Cooperative a genetic gain of NZ\$1.49 per milking doe per year could be achieved using a within-herd progeny test scheme.

LIMITATIONS

There is limited information on dairy goat genetic improvement programmes in the world, and New Zealand is a reflection of that situation. This means there are few reports to compare the results of this thesis to.

The dairy goat industry is a little known animal industry in New Zealand. This meant that only scarce information was available describing the characteristics and facts of the production system. This situation made it necessary to undertake a survey in order to get the information to describe the production system and to develop the bio-economic farm model. During the collection of this background data it became clear that there were few liveweight records and many pedigree records were confused, unreliable or there were no records at all. This made it difficult to properly define breeding groups, requiring the establishment of an unknown breed group for the analysis. The formation of this breed group is an issue to solve since most of animals in this group could be of a Saanen origin with an unknown breed percentage unfairly influencing conclusions wherever the unknown breed group was present.

Individual lactose yield records were not available making it impossible to include this trait in the selection criteria. However, for the current payment system this trait was the most economically important trait due to its contribution to total milk-solids. The importance of lactose in the payment system would suggest that lactose yield should be recorded in the future. The litter sizes recorded in the survey suggested that fertility and fecundity were not a problem and those traits were not included in the breeding objective. However, periodic monitoring of litter size should be undertaken to decide whether these traits require inclusion in the objective in the future.

It was not possible to estimate genetic parameters for all traits in the breeding objective from data available in this study. Therefore values reported in the literature were used to supplement those estimated and it was necessary to use a bending process to make the variance-covariance matrix positive definite. To avoid this problem in the future, data needs to be collected on all economically important traits.

There are many selection scheme options that potentially can be investigated and applied to the dairy goat population. For example, pedigree selection based on any fixed number of TDR different than 1+ or 3+ TDR applied in this thesis could be utilised.

Although the within-herd progeny test showed greater genetic gain than pedigree selection, an economic evaluation will be needed before implementation of progeny test scheme is undertaken. Experience of testing bulls in the dairy cattle industry suggests that progeny testing within or across herds (or countries) in dairy cattle (Cassell 2002; Miglior et al. 2005; MPI-NZ 2012) generate higher profit for dairy cattle farmers.

Previous studies on New Zealand dairy goats (Apodaca-Sarabia et al. 2009; Morris et al. 1997; Morris et al. 2006; Morris et al. 2011; Singireddy et al. 1997; Solis-Ramirez et al. 2011; Wheeler et al. 2013) and work in this thesis, suggest that dairy goat farmers in New Zealand do not share a common breeding goal. This is because dairy goat farmers are not organised into a single dairy goat farmers group. This poor integration makes it more difficult to achieve a clear definition of the breeding goal and breeding objective. In addition, it also hampers the application of a more effective genetic improvement scheme such as progeny testing or genomic selection. This poor integration also affects a common husbandry strategy to reduce the impact of genotype by environment interactions likely to be caused by mixed indoor and outdoor production systems.

FUTURE CHALLENGES AND DIRECTION

The present study focussed on the definition of a genetic improvement programme for New Zealand dairy goats. A programme of this nature demands a knowledge around genetic, phenotypic and economic parameters and husbandry practices to allow the definition of an effective breeding objective which reflects costs and revenue from important traits for the industry.

The importance of dairy goat production systems in the animal industry has been pointed out by many authors (Devendra & Haenlein 2002; Devendra 2013; Gall 1981; Solaiman 2010). However, the dairy goat industry is small from the commercial point of view when compared to the dairy cattle, poultry or pig industries. Nevertheless, from the worldwide social and ecological point of view they are more comparable. Dairy goats are present all around the world, even where no other domestic animal production industry is present. Furthermore, dairy goats are a highly profitable enterprise when used in intensive farming systems, for example to provide milk powder for special commercial niches and high quality delicatessen products and sweets. This commercial importance and high agro-ecological versatility of goats justifies and suggests viability

and sustainability to a growing dairy goat industry in New Zealand. Hence, it is strongly recommended that a cost-effective genetic improvement programme is put in place for dairy goats in New Zealand.

The use of Random Regression Models (RRM) and different mathematical functions to evaluate ten breed groups and five parities provided a variety of figures for milk traits production and evaluation across production systems and countries. The author is not aware of papers on dairy goats using RRM on mathematical functions to model the lactation trait curves. It is expected that in future studies this methodology will be used due to its ability to use one or more test day records in milking goats. This makes it possible to maximise the number of milking does under genetic evaluation for their lactation curves and minimises the cost and time for the number of TDR to be recorded per animal. However recording as much as possible is always relevant.

Milk trait yields were significantly different between purebred and crossbred groups, indicating that these traits were affected by both additive and non-additive genetic effects. However, this thesis did not evaluate non-additive genetic effects which should be analysed in the near future. Individual heterosis effects were only included as an independent variable in the statistical model to adjust for that effect when estimating least square means for traits and model parameters. The importance of heterosis in milk traits and SCS suggests there is an opportunity to choose the best breed combination to optimise milk trait yield, SCS level and other important traits already, or candidates to be, in the breeding objective.

This intent of developing a genetic improvement programme is to provide a valuable tool to increase profit per milking doe. The bio-economic farm model must be periodically up-dated (e.g. yearly) to avoid under- or over-estimation of economic values of traits or the omission of important traits with changes in market needs over time. As expected, estimation of EVs for economically important traits was a reflection of the payment system and feed costs. A stronger impact of the price per kilogram of milk-solids (revenue) than of feed costs was detected in the system. The current payment system reflects the high demand for milk-solids which is processed into milk powder and sold to niche markets. But market trends are changeable and potential new scenarios are always possible with fashion and lifestyle changes around the world requiring payment systems to be flexible and to reflect people's requirements for goat

milk products. A likely scenario is an increased value of milk protein due to healthier properties for human consumption which fortunately is associated with a higher efficiency of production. Protein in goat's milk is around 80% α , β , κ and γ caseins, which implies that changes in caseins should impact total protein yield of goats, thereby increasing revenue per milking doe and farm.

Another scenario for many countries around the world is a payment system based on milk volume because of the widespread consumption of liquid milk. However, under New Zealand conditions (chapter 7) the milk-solids concentration was penalised with negative economic values because of the energetic cost of producing fat and protein. Over several years of selection, this will result in reduced milk-solids concentration, which is undesirable. This will happen to a lesser degree, in production systems where the only milk trait in the selection objective is milk volume. Thus, care must be taken to set the selection objective correctly when genetically improving milk for a liquid milk market.

There are few genetic parameters reported for all traits in dairy goats, which should motivate breeders and scientists to record and analyse data to generate more values on traits of economic and biological importance. Values estimated in this thesis should support future work for milk traits and SCS. Genetic variation and associations between traits are of sufficient magnitude and favourable to generate a moderate genetic gain for those traits effecting profit per milking doe.

Currently, New Zealand dairy goat farmers are mostly using pedigree selection to select replacement does and bucks based on dam test-day records. As demonstrated in Chapter 9 pedigree selection will achieve slower genetic gain in the breeding objective than progeny testing. Indeed, it is highly likely that the actual genetic gains lower than estimated here because farmers are applying less selection pressure due to the lack of accurate pedigree and husbandry records.

The higher genetic gain estimated for progeny test over pedigree selection shown in Figure 10.1 demonstrates the financial importance of improved organisation and integration of dairy goat farmers. The national financial benefit of NZ\$149,000 for first year and a cumulative benefit of about 3.0 million dollars after 2 decades of selection. This financial figures provided by progeny testing over pedigree selection should

encourage the Dairy Goat Cooperative to organise farmers to implement a progeny test scheme.

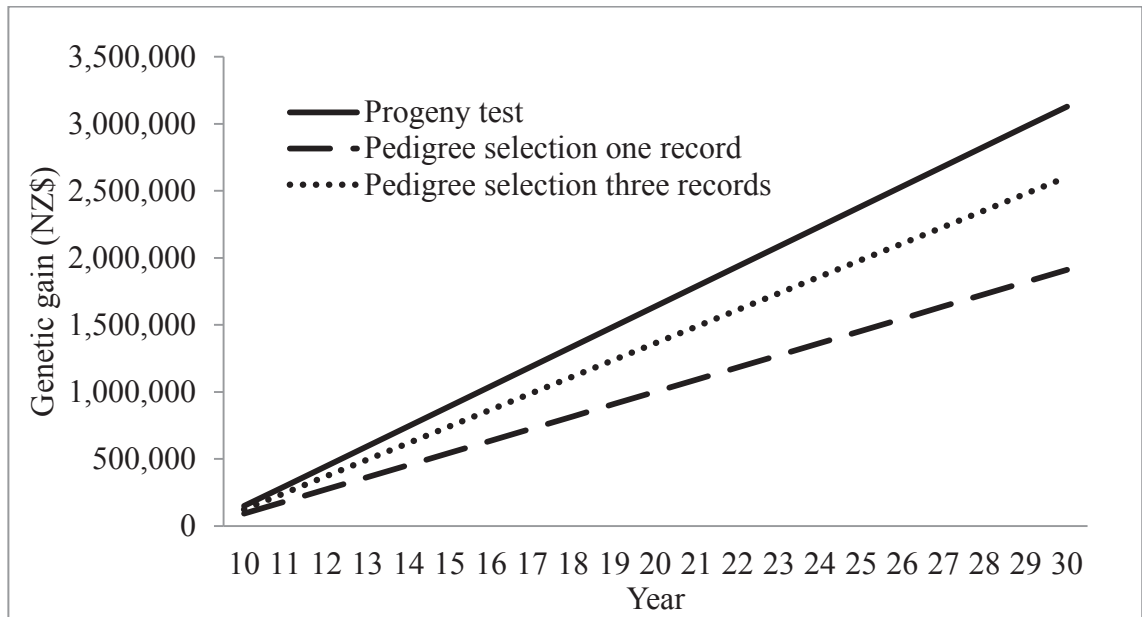

Figure 10.1. Genetic gain in the current breeding objective for three selection schemes (progeny test, pedigree selection using one or three records on dam) for the New Zealand dairy Goat Cooperative assuming 100,000 milking does and a NZ\$1.49 per milking doe and 20 years of selection (from 2010 to 2030).

Genomic selection is a modern technology with the potential to increase the rate of genetic gain. Results of success in dairy and beef cattle, swine and poultry have been widely documented as reviewed by Van Eenennaam et al. (2014). The International Goat Genome Consortium is sequencing goats to discover SNPs and to develop a high density SNP chip of at least 50K for 20-25 different breeds (Dong et al. 2012). There is some research (Barrera-Saldaña et al. 2010; Dagnachew et al. 2011; Gama & Bressan 2011) examining the potential to use genomic selection in dairy goats. However, because dairy goats have a short generation interval and high fertility and the current high cost of DNA technologies compared to the cost of an individual buck or doe it seems unlikely that dairy goat farmers will be interested in this technology in the short-term. Regardless, it would be prudent for the dairy goat industry to begin collecting suitable data and DNA samples now to prepare for the likely application of genomic tools in the future.

CONCLUSIONS

The genetic improvement programme for New Zealand dairy goats suggested in this thesis would facilitate the optimisation and monitoring of genetic gain. However, periodic updating of genetic and financial parameters is imperative to ensure the programme remains relevant. Implementation of progeny testing of bucks, is a likely priority for the Dairy Goat Cooperative, and the possible future adoption of genomic selection should benefit the New Zealand dairy goat industry and achieve higher profit for farmers.

The New Zealand dairy goat industry has high growth potential as markets develop for niche products. Business opportunities for cheese, cosmetic, sweets and other products are still unexplored in New Zealand. Expansion of the New Zealand dairy goat industry into other potential products and markets will require re-definition of the breeding objective since the relative importance of traits may change with market demand and indeed new traits may need to be included.

REFERENCES

- AFRC 1993. Energy and protein requirements of ruminants. CAB International, U.K. 159 p.
- Akaike H 1974. A new look at the statistical model identification. IEEE Transactions on Automatic Control. AC-19: 716-723.
- Ali TE, Schaeffer LR 1987. Accounting for covariances among test day milk yields in dairy cows. Canadian Journal of Animal Science 67: 637-644.
- Amer PR, Simm G, Keane MG, M.G D, Wickham BW 2001. Breeding objectives for beef cattle in Ireland. Livest Prod Sci 67: 223-239.
- Analla M, Jiménez-Gamero I, Muñoz-Serrano A, Serradilla JM, Falagán A 1996. Estimation of Genetic Parameters for Milk Yield and Fat and Protein Contents of Milk from Murciano-Granadina goats. Journal of Dairy Science 79: 1895-1898.
- Analla M, Jimenez -G, I, Muñoz-Serrano A, Serradilla JM 1995. Dairy goat breeding systems in the south of Spain. CIHEAM-Options mediterranees 11: 143-154.
- Andonov S, Odegard J, Boman IA, Svendsen M, Holme IJ, Adnoy T, Vukovic V, Klemetsdal G 2007. Validation of test-day models for genetic evaluation of dairy goats in Norway. Journal of Dairy Science 90: 4863-4871.
- Apodaca-Sarabia CA, Lopez-Villalobos N, Blair HT, Prosser CG 2009. Genetic parameters for somatic cell score in dairy goats estimated by random regression. Proceedings of the New Zealand Society of Animal Production 69: 206-209.

- Azis MA 2010. Present status of the world goat populations and their productivity. In: Electronic version in: http://www.lohmann-information.com/content/1_i_45_artikel17pdf, Accessed: January, 10. 2011.
- Barillet F 2007. Genetic improvement for dairy production in sheep and goats. *Small Ruminant Research* 70: 60-75.
- Barillet F, Marie C, Jacquin M, Lagriffoul G, Astruc JM 2001. The French Lacaune dairy sheep breed: use in France and abroad in the last 40 years. *Livestock Production Science* 71: 17-29.
- Barrera-Saldaña HA, Ascacio-Martínez JA, Sifuentes-Rincón AM, Arellano-Vera W, Arbiza SI 2010. Applications of biotechnology and genomics in goats. *Small Ruminant Research* 89: 81-90.
- Barwick S 1992. Introducing economics to modern animal breeding. *Animal breeding The modern approach A Postgraduate Foundation Publication*. Pg. 121.
- Barwick S, Fuchs W 1992. Breeding objections in beef cattle. *Animal breeding The modern approach A postgraduate Foundation Publication*. Pg. 79.
- Bett R, Kosgey I, Bebe B, Kahi A 2007a. Breeding goals for the Kenya dual purpose goat. II. Estimation of economic values for production and functional traits. *Tropical Animal Health and Production* 39: 467-475.
- Bett R, Kosgey I, Kahi A, Peters K 2009a. Analysis of production objectives and breeding practices of dairy goats in Kenya. *Tropical Animal Health and Production* 41: 307-320.
- Bett RC, Gicheha MG, Kosgey IS, Kahi AK, Peters KJ 2012a. Economic values for disease resistance traits in dairy goat production systems in Kenya. *Small Ruminant Research* 102: 135-141.

- Bett RC, Kosgey IS, Bebe BO, Kahi AK 2007b. Genetic improvement of the Kenya Dual Purpose Goat: Influence of economic values and prospects for a practical breeding programme. *Tropical Science* 47: 105-119.
- Bett RC, Kosgey IS, Kahi AK, Peters KJ 2011. Definition of breeding objectives and optimum crossbreeding levels for goats in the smallholder production systems. *Small Ruminant Research* 96: 16-24.
- Bett RC, Kosgey IS, Kahib AK, Peters KJ 2009b. Realities in breed improvement programmes for dairy goats in East and Central Africa. *Small Ruminant Research* 85: 157-160.
- Bett RC, Okeyo AM, Kosgey IS, Kahi AK, Peters KJ 2012b. Evaluation of alternative selection objectives and schemes for optimisation of village goat improvement programs. *Livestock Research for Rural Development* 24: Article 14.
- Bibby J, Toutenburg H 1978. Prediction and improved estimation in linear models. Wiley. 188 p.
- Blair HT 1989. Comparison of genetic gains per year from a variety of selection schemes. Proceedings of a seminar on sire reference schemes and across flock genetic evaluation, Department of Animal Science. Massey University. Palmerston North, New Zealand. Pg. 15-29.
- Boettcher PJ, Jairath IK, Dekkers JCM 1999. Genetic evaluation of herd life in Canada: Current status and future outlook. Vol. 21(doi:
- Boichard D, Bouloc N, Ricordeau G, Piacere A, Barillet F 1989. Genetic parameters for first lactation dairy traits in the Alpine and Saanen goat breeds. *Genetics Selection Evolution* 21: 205 - 215.

- Boldman KG, Freeman AE, Harris BL, Kuck AL 1992. Prediction of Sire Transmitting Abilities for Herd Life from Transmitting Abilities for Linear Type Traits. *Journal of Dairy Science* 75: 552-563.
- Bourdon RM 2000. Understanding animal breeding. Prentice-Hall, Inc., Upper Saddle River, NJ. USA 07458. 538 p.
- Breznik S, Malovrh S, Kovac M, Birtic D, Kompan D 2000. Additive genetic and environmental variance components for milk traits in goats with test day model. *Zootecnika* 76: 61-66.
- Brody S 1945. Bioenergetics and growth. Reinhold, New York, USA. p.
- Brotherstone S, White MS, Meyer K 2000. Genetic modelling of dairy milk yield using orthogonal polynomials and parametric curves. *Animal Science* 70: 407-415.
- Burnham KP, Anderson DR 2004. Multimodel inference: Understanding AIC and BIC in model selection. *Sociological Methods & Research* 33: 261-304.
- Buttchereit N, Stamer E, Junge W, Thaller G 2010. Evaluation of five lactation curve models fitted for fat:protein ratio of milk and daily energy balance. *Journal of Dairy Science* 93: 1702-1712.
- Camacho VE 2009. Spain goat situation: a report. In: http://www.iga-goatworld.com/2009-Country-Report-from-Spain_a105.html, Accessed: February, 4. 2011.
- Campbell AW, Waldron DF 2006. Genetic improvement of meat production in small ruminants. Proceedings of the 8th world Congress on Genetics Applied to Livestock Production, Belo Horizonte, MG. Brazil. Pg. Pg. 04.

- Capuco AV, Ellis SE, Hale SA, Long E, Erdman RA, Zhao X, Paape MJ 2003. Lactation persistency: Insights from mammary cell proliferation studies. *Journal of Animal Science* 81: 18-31.
- Carta A, Casu S, Salaris S 2009. Invited review: Current state of genetic improvement in dairy sheep. *Journal of Dairy Science* 92: 5814-5833.
- Cassell BG 2002. Genetic selection | Economic Indices for Genetic Evaluation. In: Editor-in-Chief: Hubert R (ed.) *Encyclopedia of Dairy Sciences*. Pg. 1212-1219. Elsevier, Oxford.
- Castañeda-Bustos VJ, Torres-Hernández G, Hernández-Mendo O, Díaz-Gómez MO, Pérez-Elizalde S, González-Camacho JM, Ochoa-Cordero MA, Mandeville PB 2010. Modeling of milk production and composition curves in a herd of F1 Alpine x Nubian goats in San Luis Potosi, México. *Tropical and subtropical agroecosystems* 12: 257-265.
- Charfeddine N 2000. Economic aspects of defining breeding objectives in selection programmes. Analysis and definition of the objectives in genetic improvement programmes in sheep and goats An economic approach to increase their profitability, CIHEAM-IAMZ. Publication No.43. Spain. Pg. 138.
- Charfeddine N, Alenda R, Groen AF, Carabaño MJ 1997. Genetic parameters and economic values of lactation somatic cell score and production traits. *Interbull Bulletin* 15: 84-91.
- Chikagwa-Malunga SK, Banda JW 2006. Productivity and survival ability of goats in smallholder crop/livestock farming systems in Malawi. *Livestock Research for Rural Development* 18 (1) Article #7.: Retrieved February 13, 2012, from <http://www.lrrd.org/lrrd2018/2011/chik18007.htm>.

- Coleman J, Pierce KM, Berry DP, Brennan A, Horan B 2010. Increasing milk solids production across lactation through genetic selection and intensive pasture-based feed system. *Journal of Dairy Science* 93: 4302-4317.
- Congleton WR, Everett RW 1980. Error and Bias in Using the Incomplete Gamma Function to Describe Lactation Curves. *Journal of Dairy Science* 63: 101-108.
- Crawford SB, Kosinski AS, Lin H-M, Williamson JM, Barnhart HX 2007. Computer programs for the concordance correlation coefficient. *Computer Methods and Programs in Biomedicine* 88: 62-74.
- CRV 2012. Genomic selection. In: <http://www.crv4all.co.nz/Genetics/Genomic+Selection.html>. Accessed: January 2, 2013. Vol. doi:
- Dagnachew B, Thaller G, Lien S, Adnoy T 2011. Casein SNP in Norwegian goats: additive and dominance effects on milk composition and quality. *Genetics Selection Evolution* 43: 31.
- DairyNZ 2007. Economy survey 2005-2006 . Dairy base Ltd., Hamilton, New Zealand.
- DairyNZ 2009. Economic survey 2007-08, Hamilton, New Zealand.
- DairyNZ 2010. Economic survey 2008-09, Hamilton, New Zealand.
- Davis GH, Knight TW, Sorenson E, Shackell GH, Holmes MR, Farquhar PA 1990 Mating performance in Texel rams. *Proceedings of the New Zealand Society of Animal Production* 50: 453-453.
- Davis GP, DeNise SK 1998. The impact of genetic markers on selection. *Journal of Animal Science* 76: 2331-2339.

- de Roos APW, Harbers AGF, de Jong G 2004. Random Herd Curves in a Test-Day Model for Milk, Fat, and Protein Production of Dairy Cattle in The Netherlands. *Journal of Dairy Science* 87: 2693-2701.
- Dekkers JCM 1991. Estimation of economic values for dairy cattle breeding goals: Bias due to sub-optimal management policies. *Livestock Production Science* 29: 131-149.
- Dekkers JCM, Vandervoort GE, Burnside EB 1996. Optimal Size of Progeny Groups for Progeny-Testing Programs by Artificial Insemination Firms. *Journal of Dairy Science* 79: 2056-2070.
- Devendra C 2013. Investments on Pro-poor development projects on goats: Ensuring success for improved livelihoods. *Asian-Australasian Journal of Animal Sciences* 26: 1-18.
- Devendra C, Burns M 1983. Goat production in the tropics. Commonwealth Agriculture Bureaux, Farnham Royal, U.K. 183 p.
- Devendra C, Haenlein GFW 2002. Dairy animals: Goat breeds. In: Roginski H (ed.) *Encyclopedia of Dairy Sciences*. Pg. 585-598. Elsevier, Oxford, UK.
- Dickerson G 1970. Efficiency of Animal Production—Molding the Biological Components. *Journal of Animal Science* 30: 849-859.
- Dijkstra J, France J, Dhanoa MS, Maas JA, Hanigan MD, Rook AJ, Beaver DE 1997. A Model to Describe Growth Patterns of the Mammary Gland During Pregnancy and Lactation. *Journal of Dairy Science* 80: 2340-2354.
- Dodds KG, McEwan JC, Davis GH 2007. Integration of molecular and quantitative information in sheep and goat industry breeding programmes. *Small Ruminant Research* 70: 32-41.

Dong Y, Xie M, Jiang Y, Xiao N, Du X, Zhang W, Tosser-Klopp G, Wang J, Yang S, Liang J, Chen W, Chen J, Zeng P, Hou Y, Bian C, Pan S, Li Y, Liu X, Wang W, Servin B, Sayre B, Zhu B, Sweeney D, Moore R, Nie W, Shen Y, Zhao R, Zhang G, Li J, Faraut T, Womack J, Zhang Y, Kijas J, Cockett N, Xu X, Zhao S, Wang J, Wang W 2012. sequencing and automated whole-genome optical mapping of the genome of a domestic goat (*Capra hircus*). In: <http://agbrimaeducn/wgznb2478pdf>, Accessed: June, 2. 2013.

Donkin EF, Boyazoglu PA 2010. Milk production from goats for households and small-scale farmers in South Africa. Vol. doi:

Du Plessis M, Roux CZ 1999. A breeding goal for South African Holstein Friesians in terms of economic weights in percentage units. *South African Journal of Animal Science* 29: 237-244.

Dubeuf J-P, Boyazoglu J 2009. An international panorama of goat selection and breeds. *Livestock Science* 120: 225-231.

Dudouet E 1982. Courbe de la lactation theorique de la chevre et applications. *Le Point Veterinaire* 14: 53-61.

Dzakuma JM 2010. Goats: Breeding and Genetics. In <http://www.informaworld.com/smpp/content~db=all~content=a929869218> Accessed: 2 January 2011.

Falconer DS, Mackey TFC 1996. Introduction to quantitative genetics. Fourth ed. Prentice Hall, London, UK. 464 p.

FAO 2007. The estate of the world's animal genetic resources for food and agriculture. FAO, Rome, Italy. 511 p.

FAO 2010a. FAO Statistical databases and data-sets. Vol. doi:

- FAO 2010b. FAO statistical databases and data-sets. In: <http://faostatfaorg/site/573/default.aspx#anchor>. Accessed: June,3. 2011.
- FAO 2012. FAO Statistical databases and data-sets. <http://faostatfaorg/site/573/default.aspx#anchor>.
- Faruque S, Chowdhury SA, Siddiquee NU, Afrozand MA 2010. Performance and genetic parameters of economically important traits of Black Bengal goat. J Bangladesh Agril Univ.
- Fernandez C, Sanchez-Seiger P, Navarro MJ, Garces C 1995. Modelling the voluntary dry matter intake in Murciano-Granadina dairy goats. Options Mediterranees Series A No 67: 395-399, <http://resources.ciheam.org/om/pdf/a67/06600070.pdf>. Accessed: June 10 2011.
- Fernández C, Sánchez A, Garcés C 2002. Modeling the lactation curve for test-day milk yield in Murciano-Granadina goats. Small Ruminant Research 46: 29-41.
- Fewson D 1993. Operational design of breeding programs. In: Design of breeding programs University of New England Armidale, NSW Australia.
- Franklin RD, Allison DB, Gorman BS 2014. Design and analysis of single-case research. Second ed. Psychology Press, New York, USA. 416 p.
- Fuentes-Pila J, DeLorenzo MA, Beede DK, Staples CR, Holter JB 1996. Evaluation of Equations Based on Animal Factors to Predict Intake of Lactating Holstein Cows1. Journal of Dairy Science 79: 1562-1571.
- Galina M, Palma JM, Morales R, Aguilar A, Hummel J 1995. Voluntary dry matter intake by dairy goats grazing on rangeland or on agricultural by-products in Mexico. Small Ruminant Research 15: 127-137.

- Gall C (Editor), 1981. Goat production. Academic Press, London, UK, 619 p.
- Gama LT, Bressan MC 2011. Biotechnology applications for the sustainable management of goat genetic resources. *Small Ruminant Research* 98: 133-146.
- García-Peniche TB, Montaldo HH, Valencia-Posadas M, Wiggans GR, Hubbard SM, Torres-Vázquez JA, Shepard L 2012. Breed differences over time and heritability estimates for production and reproduction traits of dairy goats in the United States. *Journal of Dairy Science* 95: 2707-2717.
- Garrick DJ 2002. Accounting for feed costs in improvement programmes for grazed dairy cattle. Proceedings of the 7th World Congress on Applied Genetics to Livestock Production Montpellier, France. Communication no. 01-36.
- Garrick DJ 2005. A Systematic Approach to the Design & Enhancement of Breeding Programmes European Association for Animal Production Uppsala Sweden. In: http://www.eaap.org/Previous_Annual_Meetings/2005Uppsala/Papers/G5.1_Garrick.pdf, Accessed: January 10, 2013.
- Garrick DJ, Lopez-Villalobos N 1998. Tomorrow's cows - Some Kiwi cows of the future. Proceedings of the Ruakura Farmers' Conference 50: 39-44.
- Garrick DJ, Snell RG 2005. Emerging technologies for identifying superior dairy cows in New Zealand. *New Zealand Veterinary Journal* 53: 390-399.
- Gaviña D 2000. Analysis and definition of the objectives in genetic improvement programmes in sheep and goats. An economic approach to increase their profitability. Pg. 138.
- Gibson JP 2005. Chapter 1. Breeding objectives. Introduction to breeding objectives. University of New South Wales, Armidale, NSW. Australia.

- Gibson JP, Jeyaruban JG 1993. The effects of BLUP evaluations, population size and restrictions on selection of close relatives on response and inbreeding in egg-laying poultry. Forty-second annual national breeders roundtable proceedings <http://www.poultryscience.org/docs/pba/1952-2003/1993/1993%20Gibson.pdf> May 6-7, 1993. Pg. 1-17.
- Gibson JP, Kennedy BW 1990. The use of constrained selection indexes in breeding for economic merit. *Theoretical and Applied Genetics* 80: 801-805.
- Gibson JP, Wilton JW 1998. Defining multiple-trait objectives for sustainable genetic improvement. *Journal of Animal Science* 76: 2303-2307.
- Gill GS, Allaire FR 1976. Relationship of Age at First Calving, Days Open, Days Dry, and Herdlife to a Profit function for Dairy Cattle. *Journal of Dairy Science* 59: 1131-1139.
- Gilmour AR, Gogel BJ, Cullis BR, Thompson R 2009. ASReml User Guide Release 3.0, VSN International Ltd, Hemel Hempstead, HP1 1ES, UK.
- Gipson TA, Grossman M 1989a. Diphasic Analysis of Lactation Curves in Dairy Goats1. *Journal of Dairy Science* 72: 1035-1044.
- Gipson TA, Grossman M 1989b. Diphasic Analysis of Lactation Curves in Dairy Goats. *Journal of Dairy Science* 72: 1035-1044.
- Gipson TA, Grossman M 1990. Lactation curves in dairy goats: a review. *Small Ruminant Research* 3: 383-396.
- Gjedrem T 1972. A study of the definition of the aggregate genotype in a selection index. *Acta Agricultural Scandinavica* 22: 11.

- Goddard ME 1998. Consensus and Debate in the Definition of Breeding Objectives. *Journal of Dairy Science* 81: 6-18.
- Goddard ME, Hayes BJ 2007. Genomic selection. *Journal of Animal Breeding and Genetics* 124: 323-330.
- González-Peña D, Acosta J, Guerra D, González N, Acosta M, Sosa D, Torres-Hernández G 2012. Modeling of individual lactation curves for milk production in a population of Alpine goats in Cuba. *Livestock Science* 150: 42-50.
- Grasser H, James JW, Van der Werf J 2006. Definition of the breeding objective. Optimal designs of breeding programmes Lecture notes: Animal breeding summer course, University of New England. Armidale, NSW. Australia. Pg. 4-9.
- Groen AF 1989a. Economic values in cattle breeding. II. Influences of production circumstances in situations with output limitations. *Livestock Production Science* 22: 17-30.
- Groen AF 1989b. Economic values in cattle breeding. I. Influences of production circumstances in situations without output limitations. *Livestock Production Science* 22: 1-16.
- Groen AF 2000. Breeding goal definition. ICAR Technical series-No3 Pp25-104
- Groen AF, Meuwissen THE, Vollema AR, Brascamp EW 1994. A comparison of alternative index procedures for multiple generation selection on non-linear profit. *Animal Science* 59: 1-9.
- Groen AF, van Arendonk JAM, Goddard ME, Vollema AR 1997. On the use of opportunity costs in deriving the economic value of herd life. *Animal Science* 65: 335-341.

- Grossman M, Koops WJ 1988. Multiphasic Analysis of Lactation Curves in Dairy Cattle. *Journal of Dairy Science* 71: 1598-1608.
- Haenlein GF 1996. Status and prospects of the dairy goat industry in the United States. *Journal of Animal Science* 74: 1173-1181.
- Haenlein GFW 2001. Past, Present, and Future Perspectives of Small Ruminant Dairy Research. *Journal of Dairy Science* 84: 2097-2115.
- Hare E, Norman HD, Wright JR 2006. Survival Rates and Productive Herd Life of Dairy Cattle in the United States. *Journal of Dairy Science* 89: 3713-3720.
- Harris BL 1989a. New Zealand dairy cow removal reasons and survival rate. *New Zealand Journal of Agricultural Research* 32: 355-358.
- Harris BL 1989b. Heritability and economics of survival rate. *New Zealand Journal of Agricultural Research* 32: 359-363.
- Harris BL 1993. Breeding objectives-future directions. Proceedings of the A L Rae Symposium on animal breeding and genetics, Massey University, New Zealand. Pg. 110.
- Harris BL 1998. Breeding dairy cattle for economic efficiency: a New Zealand pasturebased system. Proceedings of the 6th World Congress for Genetics Applied to Livestock Production, Armidale, Australia. Pg. 383-386.
- Harris BL, Freeman AE 1993. Economic Weights for Milk Yield Traits and Herd Life Under Various Economic Conditions and Production Quotas. *Journal of Dairy Science* 76: 868-879.

- Harris BL, Winkelman AM, Montgomerie WA 2005. National genetic evaluation for somatic cell score. The Proceedings of the New Zealand Society of Animal Production 65: 59-62.
- Harris DL 1970. Breeding for Efficiency in Livestock Production: Defining the Economic Objectives. Journal of Animal Science 30: 860-865.
- Harris DL, Newman S 1994. Breeding for profit: synergism between genetic improvement and livestock production (a review). Journal of Animal Science 72: 2178-2200.
- Harris DL, Stewart T, S, Arboleda CR 1984. Animal breeding programs: A systematic approach to their design. p 14, USDA-ARS.AAT-NC-8. USA.
- Hart S 2008. Meat goat nutrition. Proceedings of the 23th Annual Goat Field Day, Langston, Oklahoma. USA. Pg. 58-83.
- Hayes BJ 2007. QTL Mapping, MAS, Genomic Selection. Department of Animal Science, Iowa State University, USA. Pg.16.
- Hayes JF, Hill WG 1981. Modification of Estimates of Parameters in the Construction of Genetic Selection Indices ('Bending'). Biometrics 37: 483-493.
- Hazel LN 1943. The genetic basis for constructing selection indexes. Genetics 28: 476-490.
- Henderson CR 1973. Sire evaluation and genetic trends. Proceedings of the Animal Breeding Symposium in Honor of Dr J L Lush Champaign, Illinois. USA. Pg. 10-41.
- Horngren CT, Foster G, M.D S 1997. Cost accounting a managerial emphasis. Ninth edition ed. Prentice Hal, New Jersey, U.S.A. p.

- Howe PA 1987. Practical buck management. Proceedings from Goat Seminar: 53-55.
- Huston JE, Hart PS 2002. Goat husbandry: Feeding management-intensive conditions. Encyclopedia of Dairy Sciences, London, UK
- Iloje MU, Van Vleck LD 1978. Genetics of Dairy Goats: A Review. Journal of Dairy Science 61: 1521-1528.
- Jairath L, Dekkers JCM, Schaeffer LR, Liu Z, Burnside EB, Kolstad B 1998. Genetic Evaluation for Herd Life in Canada. Journal of Dairy Science 81: 550-562.
- James AD, Ellis PR 1979. The evaluation of production and economic effects of disease: Costs and benefits of animal disease control. Proceedings of the Second International Symposium on Veterinary Epidemiology and Economics, Camberra, Australia. Pg. 365-372.
- James JW 1982. Economic aspects of developing breeding objectives: general considerations. In: Baker F, Hammond K, McClintock AE (eds.) Future developments in the genetic improvement of animals. Pg. 107. Academic Press, Sydney, Australia.
- James JW 1986. Economic evaluation of breeding objectives in sheep and goats-general considerations. Proceedings of the 3rd World Congress on Genetics Applied to Livestock Production, Lincoln, Nebraska. USA. Pg. 470-478.
- Jamrozik J, Schaeffer LR 1997. Estimates of Genetic Parameters for a Test Day Model with Random Regressions for Yield Traits of First Lactation Holsteins. Journal of Dairy Science 80: 762-770.
- Jamrozik J, Schaeffer LR 2010. Recursive relationships between milk yield and somatic cell score of Canadian Holsteins from finite mixture random regression models. Journal of Dairy Science 93: 5474-5486.

- Jamrozik J, Schaeffer LR 2012. Test-day somatic cell score, fat-to-protein ratio and milk yield as indicator traits for sub-clinical mastitis in dairy cattle. *Journal of Animal Breeding and Genetics* 129: 11-19.
- Jamrozik J, Schaeffer LR, Dekkers JCM 1997. Genetic Evaluation of Dairy Cattle Using Test Day Yields and Random Regression Model. *Journal of Dairy Science* 80: 1217-1226.
- Jensen J 2001. Genetic Evaluation of Dairy Cattle Using Test-Day Models. *Journal of Dairy Science* 84: 2803-2812.
- Johnson DI PSFWAMBM 2000. Genetics of milk characteristics in New Zealand dairy cattle. *New Zealand Society of Animal Production*. 318-319 p.
- Jones LP 1982. Economic aspects of developing breeding objectives: a specific example breeding objectives for Merino sheep. In: Barker JSF, Hammond K, McClintock AE (eds.) *Future developments in the genetic improvement of animals*. Pg. 119. Academic Press, Sydney, Australia.
- Jorjani H, Klei L, Emanuelson U 2003. A Simple Method for Weighted Bending of Genetic (Co)variance Matrices. *Journal of Dairy Science* 86: 677-679.
- Kaplan EL, Meier P 1958. Nonparametric Estimation from Incomplete Observations. *Journal of the American Statistical Association* 53: 457-481.
- Khan IK 2009. Development of models for the genetic improvement of dairy cattle under cooperative dairying conditions in Bangladesh. PhD, Massey University, Palmerston North.
- Kilgour RJ 1993. The relationship between ram breeding capacity and flock fertility. *Theriogenology* 40: 277-285.

- Kirkpatrick M, Hill WG, Thompson R 1994. Estimating the covariance structure of traits during growth and aging, illustrated with lactation in dairy cattle *Genetical Research* 64: 57-69.
- Kirkpatrick M, Lofsvold D, Bulmer M 1990. Analysis of the inheritance, selection and evolution of growth trajectories. *Genetics* 124: 979-993.
- Kluyts JF, Naser FWC, Bradfield J 2003. Development of breeding objectives for cattle breeding: Derivation of economic values. *South African Journal of Animal Science* 33: 142-158.
- Kluyts JF, Naser FWC, Bradfield J 2007. Derivation of economic values for the Simmental breed in South Africa. *South African Journal of Animal Science* 37: 107-121.
- Kosgey IS, Baker RL, Udo HMJ, Van Arendonk JAM 2006. Successes and failures of small ruminant breeding programmes in the tropics: a review. *Small Ruminant Research* 61: 13-28.
- Kosgey IS, Okeyo AM 2007. Genetic improvement of small ruminants in low-input, smallholder production systems: Technical and infrastructural issues. *Small Ruminant Research* 70: 76-88.
- Kosgey IS, Rowlands GJ, van Arendonk JAM, Baker RL 2008. Small ruminant production in smallholder and pastoral/extensive farming systems in Kenya. *Small Ruminant Research* 77: 11-24.
- Kosgey IS, van Arendonk JAM, Baker RL 2003. Economic values for traits of meat sheep in medium to high production potential areas of the tropics. *Small Ruminant Research* 50: 187-202.

- Krupová Z, Oravcová M, Krupa E, Peškovičová D 2008. Methods for calculating economic weights of important traits in sheep. *Slovakian Journal of Animal Science* 41: 24-29.
- Krupová Z, Wolfová M, Wolf J, Oravcová M, Margetín M, Peškovičová D, Krupa E, Daňo J 2009. Economic values for dairy sheep in Slovakia. *Asian-Australasian Journal of Animal Sciences* 22: 1693-1702.
- Lal GM 1982. Breeding management. In: *Commercial Banks and Goat Development Programmes*. Pg. 45. Himalaya Publishing House, India.
- Landete-Castillejos J, Gallego L 2000. Technical note: The ability of mathematical models to describe the shape of lactation curves. *Journal of Animal Science* 78: 3010-3013.
- Legarra A, Ramón M, Ugarte E, Pérez-Guzmán MD, Arranz J 2007. Economic weights of somatic cell score in dairy sheep. *Animal* 1: 205-212.
- León JM, Macciotta NPP, Gama LT, Barba C, Delgado JV 2012. Characterization of the lactation curve in Murciano-Granadina dairy goats. *Small Ruminant Research* 107: 76-84.
- Ligda C, Georgoudis AG, Gabriilidis GH 2000. Definition of the breeding objective on the Greek dairy prolific ewes. Analysis and definition of the objectives in genetic improvement programmes in sheep and goats An economic approach to increase their profitability, Spain. Pg. 138.
- Lin LIK 1989. A Concordance Correlation Coefficient to Evaluate Reproducibility. *Biometrics* 45: 255-268.
- Lin LIK 2000. A Note on the Concordance Correlation Coefficient. *Biometrics* 56: 324-325.

- Lindsay D, Skerrit J 2003. Improved breeding in dairy goats and milking sheep. RIRDC Rural Industries Research and Development Corporation 02/150: 71.
- Liu YX, Zhang J, Schaeffer LR, Yang RQ, Zhang WL 2006. Short Communication: Optimal Random Regression Models for Milk Production in Dairy Cattle. *Journal of Dairy Science* 89: 2233-2235.
- Lopes FB, Borjas AdLR, da Silva MC, Facó O, Lôbo RN, Fiorvanti MCS, McManus C 2012. Breeding goals and selection criteria for intensive and semi-intensive dairy goat system in Brazil. *Small Ruminant Research* 106: 110-117.
- Lopez-Villalobos N 1998. Effects of crossbreeding and selection on the productivity and profitability of the New Zealand dairy industry. PhD Thesis, Massey University, Palmerston North, New Zealand. Palmerston North, New Zealand.
- Lopez-Villalobos N, Garrick DJ 2001. Estimation of genetic parameters for lactation yields of milk, fat and protein of New Zealand dairy goats. *Journal of Animal Science* 79 (Suppl. 1): 70.
- Lopez-Villalobos N, Garrick DJ 2003. Economic heterosis and breed complementarity for dairy cattle in New Zealand. 7th World Congress on Genetics Applied to Livestock Production, Montpellier, France. Communication No. 01-37
- Lopez-Villalobos N, Garrick DJ 2005. Methodology for the design and enhancement of genetic improvement programs illustrated in the context of the New Zealand dairy industry. *Agrociencia* IX: 553-568.
- Macciotta NPP, Dimauro C, Steri R, Cappio-Borlino A 2008. Mathematical modelling of goat lactation curves. In: Cannas A, Pulina C (eds.) *Dairy Goats Feeding and Nutrition*. Pg. 31-46. CAB International, Wallingford, UK.

- Macciotta NPP, Vicario D, Cappio-Borlino A 2005. Detection of Different Shapes of Lactation Curve for Milk Yield in Dairy Cattle by Empirical Mathematical Models. *Journal of Dairy Science* 88: 1178-1191.
- Macciotta NPP, Vicario D, Di Mauro C, Cappio-Borlino A 2004. A Multivariate Approach to Modeling Shapes of Individual Lactation Curves in Cattle. *Journal of Dairy Science* 87: 1092-1098.
- Mavrogenis AP, Papachristoforou C 2000. Genetic and phenotypic relationships between milk production and body weight in Chios sheep and Damascus goats. *Livestock Production Science* 67: 81-87.
- Mayeres P, Stoll J, Bormann J, Reents R, Gengler N 2004. Prediction of Daily Milk, Fat, and Protein Production by a Random Regression Test-Day Model. *Journal of Dairy Science* 87: 1925-1933.
- McClintock AE, Cunningham EP 1974. Selection in dual purpose cattle populations: defining the breeding objective. *Animal Science* 18: 237-247.
- Meijering A 1986. Dystocia in dairy cattle breeding with special attention to sire evaluation for categorical traits. PhD, Wageningen Agr University, Wageningen.
- Mellado M, Cantú L, Suárez JE 1996. Effects of body condition, length of breeding period, buck:doe ratio, and month of breeding on kidding rates in goats under extensive conditions in arid zones of Mexico. *Small Ruminant Research* 23: 29-35.
- Menéndez-Buxadera A, Molina A, Arrebola F, Gil MJ, Serradilla JM 2010. Random regression analysis of milk yield and milk composition in the first and second lactations of Murciano-Granadina goats. *Journal of Dairy Science* 93: 2718-2726.

- Miglior F, Muir BL, Van Doormaal BJ 2005. Selection Indices in Holstein Cattle of Various Countries. *Journal of Dairy Science* 88: 1255-1263.
- Miglior F, Sewalem A, Jamrozik J, Bohmanova J, Lefebvre DM, Moore RK 2007. Genetic Analysis of Milk Urea Nitrogen and Lactose and Their Relationships with Other Production Traits in Canadian Holstein Cattle. *Journal of Dairy Science* 90: 2468-2479.
- Moav R, Moav J 1966. Profit in a broiler enterprise as a function of egg production of parent stocks and growth rate of their progeny. *British Poultry Science* 7: 5-15.
- Moioli B, Pilla F, Tripaldi C 1998. Detection of milk protein genetic polymorphisms in order to improve dairy traits in sheep and goats: a review. *Small Ruminant Research* 27: 185-195.
- Montaldo H, Almanza A, Juárez A 1997. Genetic group, age and season effects on lactation curve shape in goats. *Small Ruminant Research* 24: 195-202.
- Montaldo HH, Torres-Hernández G, Valencia-Posadas M 2010. Goat breeding research in Mexico. *Small Ruminant Research* 89: 155-163.
- Morand-Fehr P 1991. Goat nutrition No. 46. p 368. EAAP Publication, Wageningen, The Netherlands.
- Morand-Fehr P, Amaro RP, Rubiño L, Branca A, Santucci PA, Hadji Panayiotou M 1992. Assessment of goat body condition and its use for feeding management. *Proceedings of the 5th International Conference in Goats, New Delhi, India*. Pg. 212.
- Morris CA, Wheeler M, Foote BJ 2011. Relationships between live weight and herd-test traits in a Saanen goat herd in New Zealand. *New Zealand Journal of Agricultural Research* 54: 315-320.

- Morris CA, Wheeler M, Hosking BC, Watson TG, Hurford AP, Foote BJ, Foote JF 1997. Genetic parameters for milk yield and faecal nematode egg count in Saanen does. *New Zealand Journal of Agricultural Research* 40: 523-528.
- Morris CA, Wheeler M, Lanuzel M 2006. Genetic trend and parameter estimates for milk yield traits and kidding date in a Saanen goat herd in New Zealand. *New Zealand Journal of Agricultural Research* 49: 175-181.
- Motulski HJ, Christopoulos A 2003. Fitting models to biological data using linear and non-linear regression. A practical guide to curve fitting. GraphPad Software Inc. www.graphpad.com, San Diego, Cal. USA. p.
- MPI-NZ 2012. The New Zealand Dairy Herd Improvement Industry: Transfer of the Core Database and Review of Regulatory Settings. MPI Discussion Paper No: 2012/ 26: Ministry of Primary Industries. New Zealand Government. In: <http://www.mpi.govt.nz/news-resources/publications.aspx>. Accessed: July 5, 2013.
- Mrode RA 2005. Linear models for the prediction of animal breeding values. Second ed. CABI International publishing, Wallingford, UK,. 341 p.
- Naude RT, Hofmeyr HS 1981. Meat production. In: Gall C (ed.) *Goat production*. Pg. 285-307. Academic Press.
- Newman S, Morris CA, Baker RL, Nicol GB 1992. Genetic improvement of beef cattle in New Zealand: Breeding objective. *Livestock Production Science* 32: 111.
- Nielsen HM, Christensen LG, Groen AF 2005. Derivation of Sustainable Breeding Goals for Dairy Cattle Using Selection Index Theory. *Journal of Dairy Science* 88: 1882-1890.

- Notter DR, Baker RL, Cockett NE 2007. The outlook for quantitative and molecular genetic applications in improving sheep and goats. *Small Ruminant Research* 70: 1-3.
- NZAEL 2012. New Zealand animal evaluation. Web page accessed: June 6, 2012: <http://www.nzael.co.nz/all-about-bw/economic-values>.
- Orr M 2010. Farming dairy goats: an introduction. In: <http://www.lifestyleblock.co.nz/goats/dairygoats/article/846-farming-dairy-goats-introduction.html>. Vol. doi:
- Otuma MO, Osakwe II 2008. Estimation of Genetic Parameters of Growth Traits in Nigeria Sahelian Goats. *Journal of Animal and Veterinary Advances* 7: 535-538.
- Park H, Stefanski LA 1998. Relative-error prediction. *Statistics & Probability Letters* 40: 227-236.
- Park YW, Haenlein GFW 2010. Milk Production. In: Solaiman SG (ed.) *Goat Science and Production*. Pg. 17. Wiley-Blackwell, Ames, Iowa. USA.
- Park YW, Juárez M, Ramos M, Haenlein GFW 2007. Physico-chemical characteristics of goat and sheep milk. *Small Ruminant Research* 68: 88-113.
- Pfister JA, Malechek JC 1986. The Voluntary Forage Intake and Nutrition of Goats and Sheep in the Semi-Arid Tropics of Northeastern Brazil. *Journal of Animal Science* 63: 1078-1086.
- Philipson J, Banos G, Arnason T 1994. Present and Future Uses of Selection Index Methodology in Dairy Cattle. *Journal of Dairy Science* 77: 3252-3261.

- Ponzoni RW 1986. A profit equation for the definition of the breeding objective of Australian merino sheep. *Journal of Animal Breeding and Genetics* 103: 342-357.
- Ponzoni RW 1988. The derivation of economic values combining income and expense in different ways: An example with Australian Merino Sheep. *Journal of Animal Breeding and Genetics* 105: 143-153.
- Ponzoni RW, Gifford DR 1990. Developing breeding objectives for Australian Cashmere Goats. *Journal of Animal Breeding and Genetics* 107: 351-370.
- Ponzoni RW, Newman S 1989. Developing breeding objectives for Australian beef cattle production. *Animal Production* 49: 35-47.
- Pritchard T, Coffey M, Mrode R, Wall E 2013. Genetic parameters for production, health, fertility and longevity traits in dairy cows. *Animal : an international journal of animal bioscience* 7: 34-46.
- Prosser C 2010. Personal communication. Dairy Goat Cooperative of New Zealand. Ltd., Hamilton, New Zealand.
- Pryce JE, Harris BL 2006. Genetics of Body Condition Score in New Zealand Dairy Cows. *Journal of Dairy Science* 89: 4424-4432.
- Ptak E, Horst HS, Schaeffer LR 1993. Interaction of Age and Month of Calving with Year of Calving for Production Traits of Ontario Holsteins. *Journal of Dairy Science* 76: 3792-3798.
- Pyle WW, Larson KD 1981. *Fundamental accounting principles*. Homewood, Illinois, USA. p.

- Rabasco A, Serradilla JM, Padilla JA, Serrano A 1993. Genetic and non-genetic sources of variation in yield and composition of milk in Verata goats. *Small Ruminant Research* 11: 151-161.
- Ramírez RG, Rodríguez A, Tagle LA, Del Valle AC, González J 1990. Nutrient content and intake of forage grazed by range goats in Northeastern Mexico. *Small Ruminant Research* 3: 435-448.
- Ramón M, Legarra A, Ugarte E, Garde JJ, Pérez-Guzmán MD 2010. Economic weights for major milk constituents of Manchega dairy ewes. *Journal of Dairy Science* 93: 3303-3309.
- Rendel JM, Jackson RG, Harris BL, Allison T, Shannon P, Buton L, Tempero H 1996. Assessing the value of breeding technologies to dairy farmers. *Proceedings of the New Zealand Society of Animal Production* 56: 22-24.
- Rendel JM, Robertson A 1950. Estimation of genetic gain in milk yield by selection in a closed herd of dairy cattle. *Journal of Genetics* 50: 1-8.
- Reynolds MP 2010. Saanens. The Great Goats. In: http://www.dairygoatjournal.com/issues/87/87-1/saanens_the_great_white_goats.html Accessed: 19 October 2010.
- Ribas M, Gutierrez M 2001. Primeros resultados de producción de leche y duración de la lactancia de razas caprinas especializadas en Cuba. *Revista Cubana de Ciencias Agrícolas* 35: 105-112.
- Ricordeau G 1981. Genetics: Breeding plans. In: Gall C (ed.) *Goat Production*. Pg. 58. Academic Press, London, UK.
- Robertson A 1957. Optimum Group Size in Progeny Testing and Family Selection. *Biometrics* 13: 442-450.

- Rupp R, Boichard D 1999. Genetic Parameters for Clinical Mastitis, Somatic Cell Score, Production, Udder Type Traits, and Milking Ease in First Lactation Holsteins. *Journal of Dairy Science* 82: 2198-2204.
- Rupp R, Clément V, Piacere A, Robert-Granié C, Manfredi E 2011. Genetic parameters for milk somatic cell score and relationship with production and udder type traits in dairy Alpine and Saanen primiparous goats. *Journal of Dairy Science* 94: 3629-3634.
- Rupp R, Lagriffoul G, Astruc JM, Barillet F 2003. Genetic Parameters for Milk Somatic Cell Scores and Relationships with Production Traits in French Lacaune Dairy Sheep. *Journal of Dairy Science* 86: 1476-1481.
- Ruvuna F, Kogi JK, Taylor JF, Mkuu SM 1995. Lactation curves among crosses of Galla and East African with Toggenburg and Anglo Nubian goats. *Small Ruminant Research* 16: 1-6.
- Sadeghi-Sefidmazgi A, Moradi-Shahrbabak M, Nejati-Javaremi A, Miraei-Ashtiani SR, Amer PR 2011. Estimation of economic values and financial losses associated with clinical mastitis and somatic cell score in Holstein dairy cattle. *Animal* 5: 33-42.
- Samoré AB, Groen AF, Boettcher PJ, Jamrozik J, Canavesi F, Bagnato A 2008. Genetic Correlation Patterns Between Somatic Cell Score and Protein Yield in the Italian Holstein-Friesian Population. *Journal of Dairy Science* 91: 4013-4021.
- Sauvant D 1988. La modelisation de la digestion dans le rumen. *Reproduction, nutrition and development* 28: 33-58.
- Schaeffer LR 2004. Application of random regression models in animal breeding. *Livestock Production Science* 86: 35-45.

- Schaeffer LR, Jamrozik J 2008. Random regression models: a longitudinal perspective. *Journal of Animal Breeding and Genetics* 125: 145-146.
- Schaeffer LR, Jamrozik J, Kistemaker GJ, Van Doormaal J 2000. Experience with a Test-Day Model. *Journal of Dairy Science* 83: 1135-1144.
- Serrano M, Pérez-Guzmán MD, Montoro V, Jurado JJ 2003. Genetic analysis of somatic cell count and milk traits in Manchega ewes: Mean lactation and test-day approaches. *Livestock Production Science* 84: 1-10.
- Shepperd RL, O'Donnell DK 1979. A Review of the New Zealand goat Industry. Agricultural Economics Research Unit. , Lincoln College, New Zealand.
- Shrestha JNB, Fahmy MH 2005. Breeding goats for meat production: a review: 1. Genetic resources, management and breed evaluation. *Small Ruminant Research* 58: 93-106.
- Shrestha JNB, Fahmy MH 2007a. Breeding goats for meat production: 3. Selection and breeding strategies. *Small Ruminant Research* 67: 113-125.
- Shrestha JNB, Fahmy MH 2007b. Breeding goats for meat production: 2. Crossbreeding and formation of composite population. *Small Ruminant Research* 67: 93-112.
- Silvestre AM, Martins AM, Santos VA, Ginja MM, Colaço JA 2009. Lactation curves for milk, fat and protein in dairy cows: A full approach. *Livestock Science* 122: 308-313.
- Silvestre AM, Petim-Batista F, Colaço J 2006. The Accuracy of Seven Mathematical Functions in Modeling Dairy Cattle Lactation Curves Based on Test-Day Records From Varying Sample Schemes. *Journal of Dairy Science* 89: 1813-1821.

- Singireddy SR, Lopez-Villalobos N, Garrick DJ 1997. Across-breed genetic evaluation of New Zealand dairy goats. *Proceedings of the New Zealand Society of Animal Production* 57: 43-45.
- Smith C 1983. Effects of Changes in Economic Weights on the Efficiency of Index Selection. *Journal of Animal Science* 56: 1057-1064.
- Smith C, James JW, Brascamp EW 1986. On the derivation of economic weights in livestock improvement. *Animal Science* 43: 545-551.
- Solaiman SG (Editor), 2010. *Goat Science and Production*. Wiley-Blackwell, 425 p.
- Solis-Ramirez J, Lopez-Villalobos N, Blair HT 2011. Dairy goat production systems in Waikato, New Zealand. *Proceedings of the New Zealand Society of Animal Production* 71: 86-91.
- Solis-Ramirez J, Lopez-Villalobos N, Blair HT 2012. Economic values for New Zealand dairy goats. *Proceedings of the New Zealand Society of Animal Production* 72: 166-168.
- Solis-Ramirez J, Mendoza-Moreno S 2005. *Industrializacion de la leche de cabra*. Primerat ed. Universidad Autonoma Chapingo, Chapingo, Mexico. 156 p.
- Spelman RJ, Garrick DJ 1997. Effect of Live Weight and Differing Economic Values on Responses to Selection for Milk Fat, Protein, Volume, and Live Weight. *Journal of Dairy Science* 80: 2557-2562.
- Spiegel MR 1971. *Advanced mathematics for engineers and scientists*, New York, USA. 376 p.

- Stewart TS, Harris DL, Schimckel AP, Lofgren DL 1986. A bio-economic objective for swine improvement. *Proceedings of the 3th World Congress on Genetics Applied to Livestock Production* 10: 87.
- Stott AW 1994. The economic advantage of longevity in the dairy cow. *Journal of Agricultural Economics* 45: 113-122.
- Strabel T, Szyda J, Ptak E, Jamrozik J 2005. Comparison of Random Regression Test-Day Models for Polish Black and White Cattle. *Journal of Dairy Science* 88: 3688-3699.
- Swalve HH 2000. Theoretical Basis and Computational Methods for Different Test-Day Genetic Evaluation Methods. *Journal of Dairy Science* 83: 1115-1124.
- Thiruvankadan AK, Murugan M, Karunanithi K, Muralidharan J, Chinnamani K 2009. Genetic and non-genetic factors affecting body weight in Tellicherry goats. *South African Journal of Animal Science* 39 (Supplement 1): 107-111.
- Tholon P, Queiroz SA, Ribeiro AC, Resende KT, Ribeiro SDA 2001. Quantitative genetic study of milk production in goats of the Saanen breed. *Archivos Latinoamericanos de Produccion Animal* 9: 1-5.
- Torres-Vazquez JA, Valencia-Posadas M, Castillo-Juarez H, Montaldo HH 2009. Genetic and phenotypic parameters of milk yield, milk composition and age at first kidding in Saanen goats from Mexico. *Livestock Science* 126: 147-153.
- Torres-Vazquez JA, Valencia-Posadas M, Castillo-Juarez H, Montaldo HH 2010. Genetic and phenotypic trends for milk yield and milk composition traits of Saanen goats from Mexico. *Revista Mexicana de Ciencias Pecuarias* 1: 337-348.
- Tozer PR, Stokes JR 2002. Producer Breeding Objectives and Optimal Sire Selection. *Journal of Dairy Science* 85: 3518-3525.

- Val-Arreola D, Kebreab E, Dijkstra J, France J 2004. Study of the Lactation Curve in Dairy Cattle on Farms in Central Mexico. *Journal of Dairy Science* 87: 3789-3799.
- Valencia M, Dobler J, Montaldo HH 2007. Genetic and phenotypic parameters for lactation traits in a flock of Saanen goats in Mexico. *Small Ruminant Research* 68: 318-322.
- Valencia PM, Dobler L, J, Montaldo HH 2005. Genetic trends for milk yield in a flock of Saanen goats in Mexico. *Small Ruminant Research* 57: 281-285.
- Van Arendonk JAM 1991. Use of Profit Equations to Determine Relative Economic Value of Dairy Cattle Herd Life and Production from Field Data. *Journal of Dairy Science* 74: 1101-1107.
- Van Arendonk JAM, Branscamp EW 1990. Economic consideration in dairy cattle breeding. *Proceedings of the 4th World congress on Genetics Applied to Livestock Production, Edimburgh, Scotland.* Pg. 78.
- Van der Werf JHJ, Marshall K, Lee S 2007. Methods and experimental designs for detection of QTL in sheep and goats. *Small Ruminant Research* 70: 21-31.
- Van Eenennaam AL, Weigel KA, Young AE, Cleveland MA, Dekkers JCM 2014. *Applied Animal Genomics: Results from the Field.* *Annual Review of Animal Biosciences* 2: 105-139.
- Van Vleck LD 1979. *Notes on the theory and application of selection principles for the genetic improvement of animals.* Cornell University, Ithaca, New York. USA. 220 p.
- VanRaden PM 2004. Invited Review: Selection on Net Merit to Improve Lifetime Profit. *Journal of Dairy Science* 87: 3125-3131.

- VanVleck LD 1964. Sampling the Young Sire in Artificial Insemination. *Journal of Dairy Science* 47: 441-446.
- Veerkamp RF, Dillon P, Kelly E, Cromie AR, Groen AF 2002. Dairy cattle breeding objectives combining yield, survival and calving interval for pasture-based systems in Ireland under different milk quota scenarios. *Livestock Production Science* 76: 137-151.
- Visscher PM, Bowman PJ, Goddard ME 1994. Breeding objectives for pasture based dairy production systems. *Livestock Production Science* 40: 123-137.
- Visser A, Lopez-Villalobos N, H MPC 2012. Validation of a bio-economic dairy production model. *Proceedings of the New Zealand Society of Animal Production* 72: 139-143.
- Vukasinovic N, Moll J, Casanova L 2001. Implementation of a Routine Genetic Evaluation for Longevity Based on Survival Analysis Techniques in Dairy Cattle Populations in Switzerland. *Journal of Dairy Science* 84: 2073-2080.
- Vukasinovic N, Moll J, Künzi N 1995. Genetic relationships among longevity, milk production, and type traits in Swiss Brown cattle. *Livestock Production Science* 41: 11-18.
- Weigel DJ, Cassell BG, Hoeschele I, Pearson RE 1995. Multiple-Trait Prediction of Transmitting Abilities for Herd Life and Estimation of Economic Weights Using Relative Net Income Adjusted for Opportunity Cost. *Journal of Dairy Science* 78: 639-647.
- Weller JI, Ezra E 1997. Genetic Analysis of Somatic Cell Score and Female Fertility of Israeli Holsteins with an Individual Animal Model. *Journal of Dairy Science* 80: 586-593.

- Weller JI, Pasternak H, Groen AF 1996. Selection indices for non-linear breeding objectives, selection for optima. Proceedings International Workshop on genetic improvement of functional traits in cattle, Glembloux, Belgium. Pg. 206.
- Welper RD, Freeman AE 1992. Genetic Parameters for Yield Traits of Holsteins, Including Lactose and Somatic Cell Score¹. Journal of Dairy Science 75: 1342-1348.
- Wheeler M, Foote BJ, Foote JF 2013. Genetic parameters of stayablity measures in a dairy goat herd. Proceedings of the New Zealand Society of Animal Production 73: 165-167.
- Wilmink JBM 1987a. Adjustment of test-day milk, fat and protein yield for age, season and stage of lactation. Livestock Production Science 16: 335-348.
- Wilmink JBM 1987b. Comparison of different methods of predicting 305-day milk yield using means calculated from within-herd lactation curves. Livestock Production Science 17: 1-17.
- Wilton JW, Miller SP, Lezenby MT 1998. Developments in multiple trait selection practices considering multiple breeds and an optimal product. Proceedings of the 6th World Congress on Genetics Applied to Livestock Production, Armidale, NSW. Australia. Pg. 2183-2194.
- Wilton JW, van Vleck LD 1968. Selection of Dairy Cows for Economic Merit. Journal of Dairy Science 51: 1680-1688.
- Wolfová M, Wolf J, Krupová Z, Kica J 2009a. Estimation of economic values for traits of dairy sheep: I. Model development. Journal of Dairy Science 92: 2183-2194.

Wolfová M, Wolf J, Krupová Z, Margetín M 2009b. Estimation of economic values for traits of dairy sheep: II. Model application to a production system with one lambing per year. *Journal of Dairy Science* 92: 2195-2203.

Wood PDP 1967. Algebraic Model of the Lactation Curve in Cattle. *Nature* 216: 164-165.

Zaharia N, Pascal C, Zaharia R, Sava CA, Atanasiu T 2011. Evaluation of milk production of goats populations from North-Eastern Romania. *Lucrări Științifice - Seria Zootehnie*. Vol. 55(16) doi: http://www.uaiasi.ro/revista_zoo/index.php?lang=ro&pagina=vol55.html.

Zumbach B, Tsuruta S, Misztal I, Peters KJ 2008. Use of a test day model for dairy goat milk yield across lactations in Germany. *Journal of Animal Breeding and Genetics* 125: 160-167.