

Copyright is owned by the Author of the thesis. Permission is given for a copy to be downloaded by an individual for the purpose of research and private study only. The thesis may not be reproduced elsewhere without the permission of the Author.

PASTURE AVAILABILITY AND COMPOSITION
IN RELATION TO
DIET SELECTION AND DIET QUALITY
BY GRAZING SHEEP

A thesis
presented in partial fulfilment of the requirements
for the degree
of

MASTER OF AGRICULTURAL SCIENCE

at

Massey University

Murray Clive Guy

1979

MASSEY UNIVERSITY

1.* (a) I give permission for my thesis, entitled
PASTURE AVAILABILITY AND COMPOSITION IN
RELATION TO DIET SELECTION AND DIET
QUALITY BY GRAZING SHEEP.

to be made available to readers in the Library under the conditions determined by the Librarian.

(b) ~~I agree to my thesis, if asked for by another institution, being sent away on temporary loan under conditions determined by the Librarian.~~

(c) ~~I also agree that my thesis may be copied for Library use.~~

2. * I do not wish my thesis, entitled

~~.....
.....
.....
to be made available to readers or to be sent to other institutions without my written consent within the next two years.~~

Signed She. C. Gray

Date 1-3-79

* Strike out the sentence or phrase which does not apply.

The Library
Massey University
Palmerston North, N.Z.

The copyright of this thesis belongs to the author. Readers must sign their name in the space below to show that they recognise this. They are asked to add their permanent address.

Name and Address

Date

.....
.....
.....
.....
.....

ABSTRACT

Some factors influencing grazing behaviour, diet selection and diet quality by sheep were investigated. The influences of pasture availability, accessibility, composition and digestibility on diet selection by grazing sheep at two stocking rates (24 and 36 sheep per hectare) over three-day grazing periods during two seasons (summer and autumn) were examined. The stocking rates were replicated twice and measurements were recorded at six intervals, each a three-day grazing period, over the summer and autumn seasons. Dietary samples were obtained by the use of oesophageal fistulated sheep, and comparisons between extrusa samples and cut pasture were made. Pasture type contrasted between seasons with extremes of availability, structure, accessibility and quality. These evolving pasture types and their changing properties are discussed.

Sheep grazing pasture have the ability to be selective, the extent of diet selection being dependent on pasture properties of availability, composition and quality. Diet preference is for the green leaf component of the pasture with avoidance of mature stem and dead matter. However in situations of low pasture availability and poor accessibility of the preferred green leaf component, increasing amounts of dead herbage were ingested, as was evidenced in comparisons between periods and during three-day grazing periods.

Digestibility values of the sheeps' diets are higher than corresponding values from available pasture the magnitude of the difference being dependent on pasture composition, availability and accessibility, ie. the opportunity afforded for diet selection.

Descriptions of experimental site, climatic conditions and animal management are recorded. The results are discussed in relation to other research findings, and their practical implications.

ACKNOWLEDGEMENTS

Professor B.R. Watkin's guidance and encouragement was greatly valued.

Grateful acknowledgement is made also to Dr R.W. Brougham and Mr D.A. Grant for direction and assistance, Mr R.G. Keogh and Mr P. Vlieg for skilled surgical oesophageal fistulation; Dr V.J. Thomas for statistical advice and assistance; and other DSIR and Massey University staff for additional advice, services and assistance in analytical, photographic and productional aspects of this thesis.

CONTENTS

	<u>Page</u>
Title and preface	i
Abstract	ii
Acknowledgements	iv
List of figures	
List of plates	
List of tables	
<u>INTRODUCTION</u>	1
CHAPTER 1. - LITERATURE REVIEW	
Outline	3
Introduction	5
Section 1. i Intake	5
ii Diet selection	15
iii Digestibility	27
Section 2. i Methods of diet evaluation	32
CHAPTER 2. - EXPERIMENTAL OUTLINE, METHODS AND SCHEDULE	
Outline	52
Methods and measurements	59
Statistical methods	66
Schedule of experimental events	67
CHAPTER 3. - RESULTS	
1. Pasture availability and 'utilization'	69
2. Pasture Composition	73
3. Pasture Strata Composition	79
4. Animal extrusa Composition	85
5. Pasture Composition : Animal Diet Composition	90
6. Pasture Digestibility	
7. Pasture Strata Digestibility	97
8. Animal Extrusa Digestibility	97
9. Pasture Digestibility : Animal Digestibility	97
10. Pasture Species	102
11. Weed Species	107
12. Oesophageal Fistula sheep liveweight	107
13. Climate	108

CHAPTER 4. - DISCUSSION

i	Experimental objective	113
ii	Experimental design	114
iii	Experimental methods	115
iv	Experimental Results	116
	A. Animal diet (1) Composition	118
	(2) Digestibility	121
	B. Stocking rate	122
v	General Conclusions and Practical Implications	125
	APPENDICES	128
	BIBLIOGRAPHY	215

LIST OF FIGURES

	<u>Page</u>
1. Experimental Area and Layout	56
2. Pasture Availability - Summer	70
3. Pasture Availability - Autumn	71
4. Pasture Composition (%) - Summer	76
5. Pasture Composition (%) - Autumn	77
6. 'B' Strata Pasture Composition (%) - Summer	81
7. 'T' Strata Pasture Composition (%) - Summer	82
8. Animal Extrusa Composition (%) - Summer	87
9. Animal Extrusa Composition (%) - Autumn	88
10. Pasture Digestibility (OMD %) - Summer	94
11. Pasture Digestibility (OMD %) - Autumn	95
12. Pasture Strata Digestibility (OMD %)	98
13. Animal Extrusa Digestibility (OMD %) - Summer	99
14. Animal Extrusa Digestibility (OMD %) - Autumn	100
15. Pasture Digestibility : Animal Extrusa Digestibility	101
16. Mean Monthly Rainfall	109
17. Soil Temperature	110
18. Mean Monthly Windrun	111

LIST OF PLATES

	<u>Page</u>
1. Experimental Overview - Late Summer (6-3-78)	53
2. Experimental Overview - Autumn (19-5-78)	53
3. Paddock Subdivisional Electric Fencing	58
4. Water Supply and Rock Salt Availability	58
5. Hand Shears for Pasture Harvesting	61
6. Cannulae Plugs used in Oesophageal Fistulated Sheep.	61
7. Animal Bolus Extrusa	117
8. Autumn Pasture Availability	117
9. Late-Summer Pasture Availability - Treatment L (6-3-78)	123
10. Late-Summer Pasture Availability - Treatment H (6-3-78)	123
11. Post-Grazing Autumn Pasture Availability - Treatment H (19-5-78)	124
12. Post-Grazing Autumn Pasture Availability - Treatment L (19-5-78)	124

LIST OF TABLES

	<u>Page</u>
1. Percentage Utilization of Total Available Dry Matter	73
2. Percentage Strata Utilization of Total Available Dry Matter	73
3. Amount of Green Leaf (kg/ha)	74
4. Pasture Stem Availability (kg/ha)	78
5. Amount of Dead Matter (kg/ha)	79
6. Amount of Leaf (kg/ha)	83
7. Amount of Leaf per Strata (kg/ha)	83
8. Percentage Stem of Pasture Composition	84
9. Strata Dead Matter Composition (%)	85
10. Extrusa Dead Matter Composition (%)	90
11. Composition Comparison : Pasture v Diet for Leaf (L), Stem (S), Other Species (OS) and dead Matter (D) (%)	91
12. Pasture (P) v Animal (A) Composition x Period Interaction	92
13. Pasture v Animal Composition x Days Interaction	93
14. Pasture Digestibility (OMD %) (Periods x Days)	96
15. Pasture Digestibility (OMD %) (Treatments x Days)	96
16. Pasture : Animal Diet Digestibility Comparison	102
17. Species Contribution to Available Pasture	103
18. Availability of <u>Lolium perenne</u> (kg/ha)	104
19. Strata Availability of <u>Lolium perenne</u> (kg/ha)	104
20. Strata Availability of <u>Agrostis tenuis</u> (kg/ha)	105
21. Availability of <u>Holcus lanatus</u> (kg/ha)	106
22. Mean O.F. Sheep Liveweights (kg)	108

INTRODUCTION

Agricultural production systems, and in particular animal production from pasture, are important to the livelihood of New Zealand, a major producer and exporter of primary products. Over 65% of New Zealand's export earnings, on average annually, are from products of animal origin. The country's sheep farming industry is a major primary producer, having between 56 and 60 million sheep and producing annually in the vicinity of 0.6 million tonnes of meat and 0.33 million tonnes of wool (N.Z. Official Year Book 1977).

The level of productivity of sheep farming in New Zealand, and its efficiency can be greatly improved. This is illustrated by the large disparity between average farm production and that obtained from the best farms in the industry and from research trials. According to Brougham (1977) the better commercial sheep farms produce 60-100% more than the average, and animal production on lowland research stations have reached 2-3 times that of their regional average. The average sheep production from flat and rolling country in New Zealand is a low 180 kg lamb meat/hectare/year from an average stocking rate of 15-16 ewe equivalents per hectare (Brougham 1977).

Improved efficiency of animal production from pasture will result from the implementation of sound scientific principles and knowledge into management systems. Animal production is a function of intake which is dependent on

many plant, animal and environmental factors. Intergration of these factors and the implementation of these principles into management systems will improve the efficiency of animal production from pasture. The importance of scientific knowledge on the behaviour of pasture and animals at their interface can not therefore be overstated.

Pasture production, availability and quality fluctuate seasonally, being influenced by the environment, grazing management and utilization, species composition, and the physiology and growth of the individual plants. These conditions result in a variety of pasture types being "offered" to the grazing animal. Similarly the nutritional demands of the grazing animal fluctuate annually due to physiological needs (eg. pregnancy, lactation, environmental stress). Grazing behaviour and diet selection are influenced by these interacting plant and animal factors.

This study is designed to contribute to a better understanding of the grazing behaviour of sheep. Because of the dependence of animal production on energy intake, important aspects of grazing behaviour in relation to diet selection and diet quality from differing pasture conditions will be examined.

LITERATURE REVIEW - OUTLINECHAPTER 1INTRODUCTIONSECTION 1I INTAKEA IntroductionB Plant Factors

- 1 Sward Structure
- 2 Species
- 3 Varieties
- 4 Maturity
- 5 Digestibility
- 6 Herbage Availability and Residue

C Animal Factors

- 1 Physiological Status
- 2 Animal Condition
- 3 Age
- 4 Health
- 5 Animal Behaviour

D Environmental FactorsII DIET SELECTIONA IntroductionB Plant Factors

- 1 Sward Structure
- 2 Species
- 3 Maturity and Digestibility
- 4 Availability and Acceptability
- 5 Pattern

C Animal Factors

- 1 Senses
- 2 Grazing Behaviour
- 3 Physiology
- 4 Age
- 5 Species

D Management

- 1 Stocking Rate

E Environment

III	<u>DIGESTIBILITY</u>	A	<u>Introduction</u>	
		B	<u>Plant Factors</u>	1 Plant Components
				2 Species
				3 Varieties
				4 Maturity
		C	<u>Management</u>	
		D	<u>Stocking Rate</u>	
		E	<u>Environment</u>	

SECTION 2

I	<u>METHODS OF DIET</u>	A	<u>Introduction</u>	
	<u>EVALUATION</u>	B	<u>Selectivity</u>	1 Observation
				2 Plant Measurements
				3 Hand Plucking
				4 Faecal Cuticle
				5 Rumen Fistula
				6 Oesophageal Fistula
	a. Introduction			
	b. Surgery			
	c. Animal Behaviour			
	d. Extrusa Collection			
	e. Extrusa Analysis			
		C	<u>Quality</u>	1 Digestibility
				2 Nutritive Value

CHAPTER 1

INTRODUCTION

The complexity of the pastoral ecosystem, with its interacting soil-plant-animal-environment factors, ensures that any review of this system can not be simplistic. The study investigated some factors associated with the grazing, dietary selection and quality, by sheep, on pasture. The following literature review attempts to highlight principles and factors associated in such an ecosystem.

Before one can consider the factors associated with the diet selected and its inherent quality, it is essential that the principles associated with voluntary intake of the grazing animal are understood. The first section of the review highlights the interacting factors associated with intake, diet selection and diet quality. The second section reviews the methods of diet evaluation which set the scene for the study in question.

SECTION 1

I. INTAKE

A. Introduction Nutrient and energy intake are important factors influencing animal production. Intake may be influenced by characteristics of the animal, its food or the environment (Bines 1976). Raymond (1969) divides the factors determining forage intake into intrinsic factors of the forage, and extrinsic factors which depend on the method of presentation of the forage, and on environmental factors. He states that nutritive value of

a forage should be considered as the product of three parameters that affect nutritive intake. That is, nutritive intake = intake of feed x digestibility of feed x efficiency of utilization of digested feed.

B. Plant Factors 1. Sward Structure: Sward characteristics such as yield and weight of herbage per unit height, particularly the leaf component, can greatly influence grazing behaviour and the quantity and quality of feed consumed (Stobbs 1975a). To simply measure herbage yield without describing its physical distribution may give no idea of the ease with which feed can be harvested by the animal (Stobbs 1973b). Baker (1975) emphasised that the weight of standing crop per unit area, and the crops distribution in space are important extrinsic factors affecting herbage intake, through their effects on the ease of prehension by the grazing animal, of the pasture crop. He suggests that spatial distribution of tillers within a sward in terms of density, length and height, can in some circumstances be more important in their influence on intake than the amount present per unit area.

Recent studies on the vertical distribution of herbage within tropical pasture swards (Stobbs 1973a, 1973b) show that despite high dry matter yields from tropical pasture swards, they are loosely packed compared with temperate pasture swards. Sward "bulk density" as Stobbs describes it, of tropical pastures vary from 14-200 kg ha⁻¹ cm⁻¹, while temperate pastures vary from 160-410 kg ha⁻¹ cm⁻¹ (Stobbs 1975a). Similarly leaf bulk densities of tropical swards are markedly lower than temperate swards,

particularly in the uppermost layers of the sward. Consequently it is difficult for animals toprehend large quantities of leaf in each bite from these swards (Stobbs 1975a). High sward bulk density, a low stem content and a high leaf:height ratio have the major influence upon the size of bite taken by grazing animals (Stobbs, 1973b).

Chacon, Stobbs and Dale (1978) experimenting with tropical swards, found that at similar herbage yields, animal production varied greatly, depending upon canopy structure and nutritive value of herbage. Spatial distribution (mainly bulk density and leaf:stem ratio) and nutritive value (mainly digestibility and nitrogen content) of the herbage, particularly in the top of the swards, influenced the performance of stock. They concluded that greater consideration of the leafiness and nutrient content of the herbage in the upper layers of the sward is required rather than considering characteristics of the whole sward. Stobbs (1975) suggested that animal production can be improved on these tropical swards by:- (1) selecting leafy pasture plants which are easily harvested. (2) fertilizing pastures to produce dense leafy swards. (3) grazing management practices which maintain swards as near as possible to optimum for easy defoliation.

Allden and Whittaker (1970) showed that with swards of different plant density the rate of intake is not closely related to dry matter yield per unit area. For example at 1000 kg DM pasture/ha the rate of intake of yearling sheep ranged between 2.5 g and 7.5 g DM/minute for the undisturbed sward and the 90 cm plant spacing treatment respectively. These results provide strong

evidence that dry matter per unit area per se is not a reliable guide to the intrinsic availability of herbage to the grazing animal. These authors also recorded a rapid change in rate of intake with increasing tiller length (up to about 15 cm), with both lambs and two-tooths; thereafter there was little change in the rate of intake with increase in tiller length. They did, however, point out that rate of intake is only one of the components of total intake, the other being grazing time.

Inter-relations of rate of intake, size of bite, and rate of biting associated with changing tiller length, were measured by Allden and Whittaker (1970). The size of bite increased almost linearly with changing tiller length: 0.025 g DM per bite at tiller length 3.7 cm, to 0.42 g DM per bite at tiller length of 36.7 cm. By contrast, the number of bites per minute, after an initial increase from the lowest length, showed a steady decline, the highest value being 73 bites per minute at a tiller length of 5 cm, the lowest 18 bites per minute at a tiller length of 36.7 cm. There was a seven fold increase in the rate of intake of grazing sheep between tiller lengths of 3.7 and 7.7 cm, the mean intake values being 1.0 and 7.1 g DM per minute respectively. It should be noted that this study was conducted in a relatively simple temperate sward situation with a monospecific grass sward of uniform height at each availability, and in a vegetative stage of growth.

2. Species: Thornton and Minson (1973) compared the voluntary intake of eight grasses and six legumes fed to stall-housed, rumen-fistulated wethers. Their results

showed that voluntary intake of legumes was 28% higher than that of equally digestible grasses. This difference was caused by a shorter retention time (17%) and a higher amount of organic matter (14%) in the rumen digesta from legume diets than from grass diets. Daily intake of digestible organic matter was closely correlated with retention time for feeds in this study ($r = -0.93$), and the same relationship applied to both temperate and tropical feeds. Differences in voluntary intake between grasses and legumes were attributed to differences in retention time and the density to which the food was packed in the rumen.

Ulyatt (1969) concluded that clover contained less structural carbohydrate and had a higher ratio of readily fermentable to structural carbohydrate than ryegrasses. This led to a more intense rumen digestion, a higher concentration of end products of rumen digestion and a higher intake of clover than two ryegrasses assessed.

Ulyatt et al. (1977) found the feeding value of legumes to be superior to that of most grasses and graminaceous forages. The feeding value, expressed as liveweight gain of lambs, is approximately 86% higher from white clover than from perennial ryegrass. Addition of white clover to grass pastures improves the feeding value of the pasture for sheep. (Rae et al. 1963; Grimes et al. 1967; Davies 1975; Suckling 1976). Similar results with white clover have been obtained with growing calves (Collins and O'Donovan 1970; Lancashire 1971).

Jarrige, Demarquilly and Murphy (1973) in a review paper on intake of forages, state that large differences in intake

have been found at the same level of digestibility between grasses and legumes, between species within a family and also between varieties within a species. Legumes are eaten in larger amounts than grasses as they are digested more quickly.

3. Varieties: Osbourn et al's. (1966) results showed that a large difference in voluntary intake of diploid and tetraploid Italian ryegrasses existed when forages are compared on the basis of equal digestibility. At 70% digestibility the voluntary intake of the diploid variety was 16% greater than the tetraploid variety.

In trials evaluating feeding values of pasture species in terms of liveweight gains of sheep, Ulyatt (1970), found the annual ryegrasses to be consistently of higher feeding value than perennial ryegrasses. These differences have been shown to be due partly to higher herbage intake of the annual ryegrasses and partly to their higher nutritive value. (Ulyatt 1971; Ulyatt and MacRae 1971).

4. Maturity: Demarquilly and Jarrige (1973) showed a fall in intake and in organic matter digestibility with advancing maturity. They stated that the relationship between intake and digestibility can be considered as linear for each herbage species, but the slope and position of the line vary between species.

5. Digestibility: Results of Hodgson (1977) showed there to be a positive linear relationship between feed intake and digestibility. This is at variance with the relationship

postulated originally for housed animals in which feed intake increased little once the digestibility of the diet exceeded 65-70%. This early work was carried out on mature, non-productive animals, whereas the more recent results (eg. Rodriguez and Hodgson 1974) relate principally to lactating cows or animals with some capacity to grow. Rodriguez and Hodgson (1974) found herbage intake, with six month old steer calves, to be influenced primarily by the digestibility of the herbage selected; intake increasing at a constant rate as digestibility increased over the full range of values observed (55-81%). Thus, improvements in the digestibility of grazed herbage are clearly of agronomic importance.

6. Herbage Availability and Residue: Rattray and Jagusch (1978) highlighted the importance of pasture allowance by stating that it is probably the most important single factor that is responsible for differences in production per animal between farms, between years, and between stocking rates.

The relation between herbage consumption and herbage allowance is curvilinear. An increase in allowance however, may affect the quality as well as the quantity of the herbage consumed, since it increases opportunities for selective grazing (Greenhalgh et al. 1966).

Reardon (1975) in an autumn experiment with 20-month cattle, showed that when extra dry matter was supplied in the form of pasture with more dry matter per unit area, an extra 1 kg DM. lifted pasture intake by 350 gm DM. However, when extra dry matter was supplied by offering a larger area,

pasture intake remained virtually unchanged on pastures between 1700 and 2200 kg DM per hectare. At higher levels of pasture dry matter, increasing the area of pasture improved intake (eg. at 3500 kg DM/ha, offering an extra 1 kg DM raised pasture intake by about 150 gms.). These figures indicate that extra pasture dry matter offered as a longer or denser pasture, has more effect on intake than dry matter offered in the form of larger areas of pasture.

C. Animal Factors 1. Physiological Status: The grazing animal has an energy demand and attempts to eat to satisfy this demand and achieve energy balance (Ulyatt 1973). The point at which energy balance is achieved can change in response to a change in an animal's physiological status. Digestible organic matter intake is greater in pregnant (Arnold 1975) and lactating (Arnold 1975; Arnold, Dudzinski 1967b) ewes than in dry ewes.

2. Animal Condition: Growing animals given good quality ad libitum feed, after a period of underfeeding, will gain weight faster than similar animals which have not been so restricted (Wilson and Osbourn 1960). This compensatory growth occurs as a result of increased food intake (Meyer et al. 1965). Both rates of eating and time of eating may increase in this situation (Bines 1976). Intake is related to body condition as well as to body size (Arnold 1970). Thin sheep have a higher intake per unit weight than fat sheep (Allden 1968).

3. Age: Animals of different ages grazing together may have quite different intakes per unit liveweight (Langlands 1968). Arnold (1966) found that weaner sheep ate 5 g per kg more digestible organic matter than adult sheep on pastures producing diets of 55-80 per cent digestibility. He suggested that the 'growth surge' of young sheep accounted for this difference.

4. Health: Loss of appetite characterises a number of diseases, both metabolic and of infectious or parasitic origin.

5. Animal behaviour: As the quantity of herbage available declines, and animals are in competition for it, then the size of bite is reduced (Stobbs 1973a, 1973b) and the animal attempts to compensate by increasing the time spent grazing per day (Hancock 1954; Freer 1960). Eventually a point is reached where the hours of daylight, the need to ruminate or possibly fatigue, limit further grazing and consequently intake is reduced (Leaver 1976). In fairly short green pasture conditions, Arnold (1960) has shown that grazing time on green Phalaris-annual grasses-subterranean clover pasture increased linearly as the amount of pasture on offer decreased. Grazing time was more closely related to the green dry matter (GDM) than to total DM on offer. As GDM per hectare decreased from 2,400 kg to 770 kg, grazing time increased from 7.0 to 10.3 hours. He concludes that there must be a limit beyond which the increase in grazing time does not compensate for the shortage of pasture and intake cannot be maintained.

A high density of leaf within the sward as well as a low stem content were considered to be the main factors affecting bite size (Stobbs 1973b). Prehension of large bites is likely to be more difficult on tropical pasture swards than temperate swards because of a low sward bulk density and a high stem component in mature tropical swards (Stobbs 1973b). The amount of feed ingested by grazing cattle at each bite is largely dependent upon the amount of herbage, usually leaf, harvested with each sweep of the tongue (Stobbs 1973b).

D. Environmental factors In general, ruminants tend to maintain a constant energy balance by changing feed intake in proportion to their altered environmental circumstances (Baile and Forbes 1974). Food intake of cattle decreases at high temperatures and increase in cold conditions (Bines 1976).

Water restriction inhibits intake of food by mammals including ruminants (Utley, Bradley and Boling 1970). In general, there is a direct relationship between the amounts of food and water voluntarily consumed, with ruminants (eg. Bines and Davey 1970).

The animal's covering of hair or wool provides insulation, reducing changes in rate of heat loss to the environment. The greater the heat loss, the greater the increase in feed intake after shearing (Baile and Forbes 1974). Increases of 40 to 60% in intake of grazing sheep subjected to cold following shearing were obtained by Wheeler, Reardon and Lanbourne (1963).

II DIET SELECTION

A. Introduction The grazing animal exists in a complex environment, influenced by inter-relating factors of soil, plant and animal. Arnold (1964b) in a review paper on selective grazing ably illustrates the major factors influencing the diet selected by the grazing animal in the following diagram.

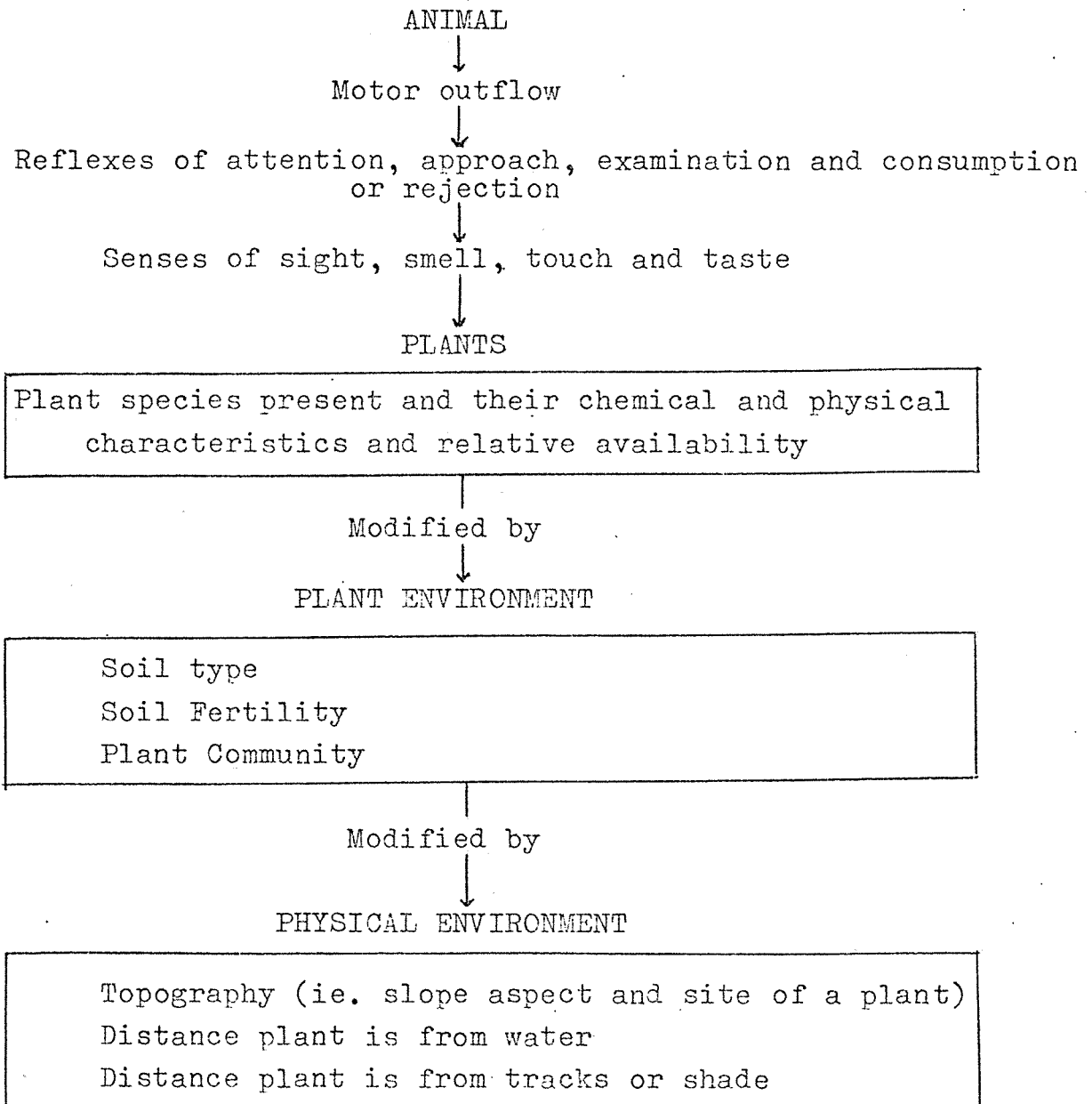

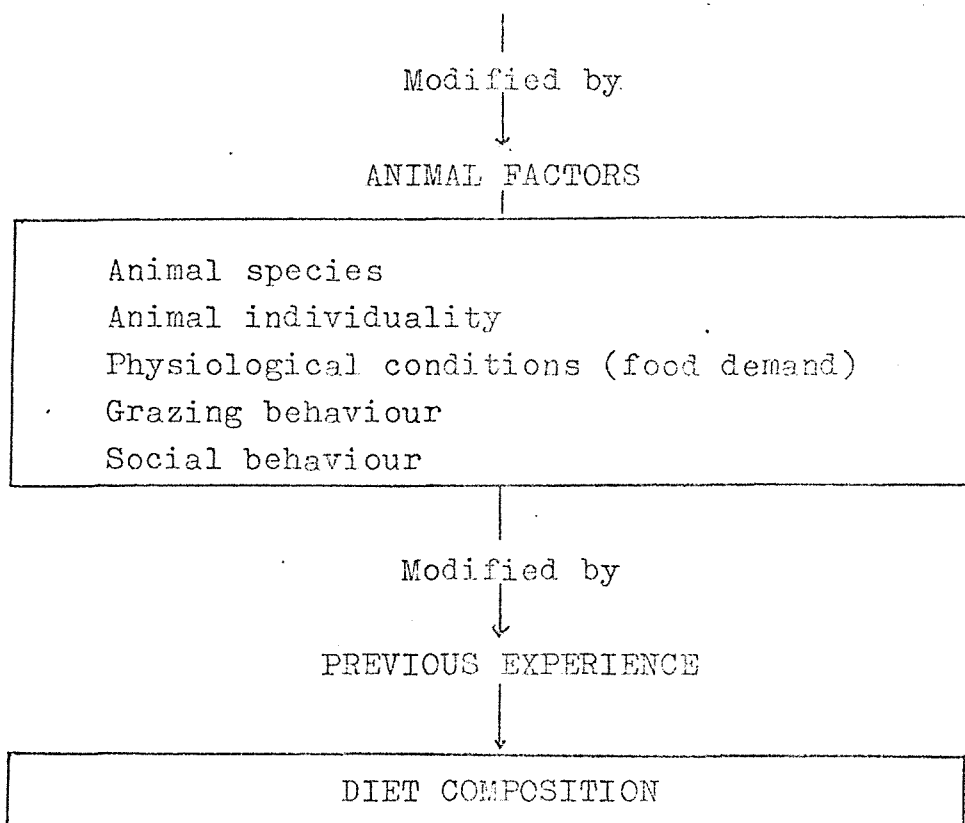

The following review section will objectively discuss these relationships with particular emphasis on the plant and animal factors influencing diet composition.

B. Plant factors 1. Sward Structure: Under grazing conditions plant species will be intermingled and the animal by its selective grazing may alter the composition of the plant community and thus be forced to alter its choice of material. One of the most important aspects of selective grazing is that it will influence the plant material actually 'available to the animal' and thus affect not only the quantity and quality of plant material eaten but also the utilization of total material available (Arnold 1964). Because of the differential acceptability of the components of a plant community the total amount of herbage on offer is rarely, so far as the animal is concerned, the amount apparently available.

In pastures the presence of dry material has an important effect on utilization and what is selected (Suckling 1964, 1976; Arnold 1964; Hodgson 1975; Stobbs 1975b; Arnold, Ball, McManus and Bush 1966; Eadie 1967; Krueger 1972). The diet is selected almost exclusively from the green components (eg. Arnold 1964; Hodgson 1975; Hamilton et al. 1973; Langlands 1974; Mulholland et al. 1977), especially when the pastures are mainly green. As the percentage of dry material in the pasture increases, the animals are unable to eat an entirely green diet (Milford 1960; Hamilton et al. 1973; Arnold et al. 1966; Alder 1969), or if so decrease their total intake.

Arnold (1964) comments that he found, even with a high grazing pressure on pasture containing 50% dry material, the sheeps diet contained 70% green components. There was, however, an almost complete suppression of preferences amongst green components as a result. Arnold, Ball, McManus and Bush (1966), at low pasture availability, measured the sheeps' diet to contain less than 4% dead matter when the pasture contained up to 40%.

When grazing pressure is low the amount of dry material present in a pasture can restrict accessibility and therefore the utilization of green components (Arnold 1964). This is particularly the case in rank pasture where the fresh green leaves and shoots are situated below the standing dry material (eg. Suckling 1964).

Grazing sheep move in a horizontal plane and select in a vertical plane (Arnold 1964). Arnold (1964) considers this fact basic to an understanding of selective grazing. Therefore the structure of a pasture can influence the diet

by preventing normal grazing and thus affecting selection.

The "availability" of a species within a plant community will influence its acceptability. That is "availability" in terms of the frequency of occurrence, yield relative to other species and accessibility, and as influenced by the acceptability of surrounding plant material (McBride, Arnold, Alexander and Lynch 1967). The presence of a disliked species, or of dry material, is detrimental to the consumption of a species known to be acceptable under other conditions (Milton 1933, 1953; Glendenning 1944; Phillips and Pfeiffer 1958; Cowlshaw and Alder 1960; Arnold 1964).

When the quantity of green herbage on offer is high, the difference in digestibility between the diet selected and the total herbage would be the result of selection within the green material for the more digestible fractions, such as leaf in preference to stem, and young herbage in preference to more mature material (eg. Hamilton, Hutchinson, Annis, Donnelly 1973; McIvor and Watkin 1973).

Arnold (1960a) measuring the diet of sheep grazing a lucerne sward, recorded no appreciable amount of stem being consumed until the amount of leaf available reached low levels (8-12%). The greater the initial amount of material the greater was the degree of selection for leaf. However as the amount of material was reduced by grazing, the degree of selection decreased; that is the decline in the percentage leaf became less (Arnold 1960a).

Arnold (1960a) notes that with a grass plant, as compared with lucerne, there is no simple choice between leaf and stem, but choice varies with stage of growth. In

the earlier stages of growth, choice is between old and young green leaves, but this is later increased to a choice between three components when stem appears.

McIvor and Watkin (1973) while studying the defoliation of cocksfoot by sheep at varying stocking rates, observed preference to be for the youngest leaves on a tiller for all treatments, in the autumn.

2. Species: Evidence suggests that sheep selectively graze legumes in mixed pasture species swards (Grimes, Watkin and Gallagher 1967; Hodge and Doyle 1967). This can be quite marked as reported by Hodge and Doyle (1967) where lambs at 14 weeks of age selected 50% of their diet as clover when its contribution to the sward was between 14 and 16%. They suggested there was a chemical or morphological change in the pasture as the season progressed which made the clover more palatable or easier to select or, conversely, the grass less palatable or more difficult to select.

Selection is more evident and dramatic in extensive range conditions than under intensive pasture management systems. An example of this is the work of Leigh and Mulham (1966) in a semi-arid area of Australia, where up to 96% of the diet was at times selected from minor constituents of the plant community. Similarly on rangeland in the U.S.A., sheep exhibit very strong preferences for certain species at different times during the growing season. For example Heady and Torell (1959) measured the diet of oesophageal fistulated sheep to consist of 30% bur clover when only 1% or less comprised the available herbage.

The presence of some disliked species can strongly influence the utilization. This has been demonstrated for a wide variety of plant associations (eg. Glendenning 1944; Milton 1933, 1953; Phillips and Pfeiffer 1958).

3. Maturity and Digestibility: As pasture species advance in maturity there is an increase in the amount of structural tissues in the plant. The cellulose cell walls become coated with lignin which is virtually indigestible (Arnold 1964). The rate and extent to which the dry matter digestibility of herbage declines with advancing maturity varies with the species and the environment, but there appears to be a well-defined pattern for nearly all species in that digestibility remains high until the onset of flowering (Arnold 1964; Minson, Raymond and Harris 1960).

Arnold (1964) noted that the digestibility of the diet of sheep grazing a similar pasture, did not decline at the same time nor to the same extent as that of ungrazed pasture. This is due to selective grazing of the more digestible components and also grazing maintaining the herbage in a younger stage of growth (Arnold 1964).

If a range of species that differs markedly in the stage of growth is available, preferences will usually be for the species with the least mature herbage (Arnold 1964d).

4. Availability and Acceptability: Arnold, Ball, McManus and Bush (1966) found that differences between the available herbage and the subsequent diet selected by grazing ewes, are greatest when the pasture is in the reproductive state. This is when the greatest bulk of herbage is available and grazing can be highly selective.

Arnold (1960b) investigated the grazing behaviour of ewes on a Phalaris tuberosa-subterranean clover pasture, at different stocking levels to produce a range in levels of pasture availability. As the amount of pasture available decreased, there was a significant increase both in the nitrogen content of available material and in the diet selected by oesophageal fistulated sheep grazing them. These differences in the quantity and quality of available pasture produced significant changes in the grazing behaviour of sheep.

5. Pattern: Arnold (1964) concluded that by selective grazing the animal will frequently reduce the area of pasture that it will graze because uneaten areas become progressively less attractive. Hercus (1961) on Otago hill country, and Suckling (1964, 1976) and Rumball (1966) on North Island hill country reached similar conclusions. Keogh (1973, 1975) noted grazing preference for sheep over the dry summer period to be firstly for urine patch herbage, and then inter-excreta areas containing white clover as opposed to those without legume. Grazing animals reject dung-fouled pasture, with the area of rejection dependent on grazing pressure and time of fouling (eg. MacLusky 1960; Greenhalgh and Reid 1969; MacDiarmid and Watkin 1971).

Jackson (1976) emphasises that grazing pattern results from the combined effects of selection by the animal and the distribution of morphological components within the sward. He presents a useful chart of 'some determinants of patterns of defoliation in a single species sward'.

Response

eg. fouling, soil
contamination

Herbage decay
Fungal taint



Interaction

Age of material

Morphological
unit eg. stem,
youngest leaf
etc.



Sward

Characteristic

Palatability — selectivity

Quality

Pattern of
Defoliation

Morphological position
in relation to total
herbage present, i.e.
above, below, amongst
or wrapped within non-
preferred material.

Availability

Linear proximity to
ground

C. Animal factors 1. Senses: Arnold (1966b) studied the influence of impairment of the senses of smell, taste and touch, either singly or in combination, on the dietary habits of sheep. Marked changes occurred in the relative acceptability of species, or strains of species, when each of these senses were impaired. He concluded that these three senses are of some importance when all pasture conditions are considered. In specific situations, however, a single one of the senses is often of paramount importance.

Preferences of diet, will be determined through the animal's special senses. Therefore, any characteristics of plants or plant communities must act through these senses. Neural responses to stimuli received will be partly innate and partly due to previous experience and physiological need of the animal. Any intelligence (nutritional wisdom) on the animal's part will be reflected in the reaction to both previous experience and physiological need (Arnold 1964d). McBride et al. (1967) illustrate evidence of poor nutritional wisdom in grazing animals, in their selective grazing of toxic plants.

Kruger, Laycock and Price (1974) studied chemical impairment of taste, smell, and touch, and physical obstruction of sight, in relation to forage preferences of sheep in a tall-forb plant community. Taste was the special sense most influential in dissecting forage preference, the other senses appeared to supplement taste. Smell was of minor importance in selection. Touch and sight related to such specific plant conditions as succulence and growth form. Simultaneous impairment of

all four senses did not result in completely random selection, but did increase preference for unpalatable plants and decrease preference for palatable ones.

2. Grazing behaviour: Arnold (1963) assessed the grazing behaviour of sheep in a temperate environment. During autumn and winter, grazing intensity generally increases from mid-morning to a peak in late-afternoon, whereas in spring and summer two main peaks of grazing occur, one in mid-morning and the other in late-afternoon. Lancashire and Keogh (1966) found similar grazing patterns with some modifications in behaviour when sheep grazed pastures of different species composition.

The grazing habits of sheep differ markedly on short and tall herbage (Arnold 1966a). The main difference is that selection in a vertical plane within the pasture plays a dominant role on tall pasture. On short pasture sheep move horizontally across the face of the herbage and select areas on which to graze. This cannot be done on tall pasture (Arnold 1966a).

3. Physiology: Forage preferences have been shown to be related to pregnancy, lactation, fatness and hunger (Jones 1952; Heady 1964a). Fat animals are highly selective.

4. Age: Food preference is influenced by age. Suckling animals once they have outgrown the inquisitive stage, generally eat only the most succulent plants or parts of plants (Jones 1952). Arnold (1966a) found that weaner sheep selected a more digestible diet than adult

sheep on the same pasture, which he described as the 'growth surge' of young sheep. However McBride et al. (1967) reported that older animals adapt to unfamiliar plants less readily than younger animals.

5. Species: Heady (1964b) makes the general statement that animal species differ in their food habits, with each species showing innate preferences for certain plants, parts of plants, or plants in particular growth stages.

Dudzinski and Arnold (1973) suggest that differences in composition of the diet between sheep and cattle arise from differences in their mechanical ability to be selective. They suggest that the larger jaw of cattle and the use of the tongue in grasping food would be a disadvantage when green herbage was short and among an abundant supply of dead plant material. Their results showed that sheep diets were consistently different from cattle diets, independent of pasture conditions, in having lower normal-acid fibre contents (3.8 units less) and higher water-soluble carbohydrates (+ 1 unit) and higher in vitro digestibility (+ 4.4 units).

Langlands and Sanson (1976) report that diets selected by sheep were of higher digestibility and nitrogen content than those selected by cattle, because they contained more green material and the green material selected by the sheep was of a higher digestibility and nitrogen content. The nutritive value of the diet of sheep varied with the availability of green forage; and that of cattle with both the availability of green forage and the bulk of forage on

offer. Cattle were the more sensitive to changes in the quantity of green material available, and differences between sheep and cattle in the nutritive value of diets were reduced as the quantity of green material and the bulk of forage increased.

Boswell (1976) showed that pasture production under sheep grazing is greater than under grazing by cattle with similar management regimes. This is supported by Monteath (1970), and Monteath, Johnstone and Boswell (1977) with Joyce (1970), recording a reverse trend. Cattle grazing restricted the production of the ryegrass component in the Invermay experiments (Boswell 1976). Monteath et al. (1977) have suggested three possible reasons for the decline in ryegrass under cattle grazing: (1) The different defoliation regimes used on cattle and sheep farmlets. (2) The uneven return of plant nutrients to pasture by cattle compared with sheep. (3) Increased soil compaction by cattle favouring more drought resistant plant species.

D. Management 1. Stocking rate: Arnold, Ball, McManus and Bush (1966) observed that in a dry summer, sheep at high grazing intensities have less green material available than sheep at low grazing intensities, and have to eat a greater proportion of mature dead herbage. Milford (1960) considers that at a time when the growth rate of herbage is less than the rate of consumption, selective grazing is likely to result in a gradual increase in the proportion of the least palatable plant fractions in the pasture. Using two stocking rates of 98 and 196 sheep per hectare, he reported sheep at both rates to graze

selectively for the leaf fractions, with a stocking rate effect. Leaf:stem ratios were reduced from 1:3.4 in the ungrazed treatment to 1:9 in the lower, and 1:11.3 in the higher stocking rates.

E. Environment The position of a plant in relation to the topographical and physical features of the country can exert considerable influence on the degree to which it is utilized (Arnold 1964). Glendenning (1944) demonstrated that distance from a watering place, distance from a trail, and steepness and length of slope can have an important effect on the utilization of a plant community. Distance from shade is important in much of Australia (Arnold 1964). Aspect can also be important. Hercus (1961) found that grazing pressure in winter on Otago hill country is concentrated on sunny faces no matter what quantity and quality of herbage is available on adjoining shaded aspects.

Soil fertility can considerably influence acceptability (Milton 1933; Hurd and Pond 1958; Cook 1959; Collett 1961). A species with a high preference ranking on one soil may have a lower ranking on another (McBride et al. 1967).

III DIGESTIBILITY

A. Introduction The nutritive value of a diet depends on the proportion of nutrients digested and on the efficiency with which these digested nutrients are absorbed and utilized within the animal's tissues. Ulyatt (1970a) defines pasture quality as a function of both intake and

nutritive value. He studied the role of digestibility in defining pasture quality and concluded that digestibility is a useful index for low and medium quality herbage, but is of limited use for high quality herbage. The ultimate criterion of pasture quality under New Zealand conditions must be the production of the grazing ruminant (Ulyatt 1970a).

Digestibility only measures the difference between the food consumed and faecal output. It tells nothing of the process of digestion, nor of the efficiency of end-product utilization by the animal. Digestibility is an effect of the process of digestion, not a cause (Ulyatt 1970a).

B. Plant Factors 1. Plant Components: Within a sward, there can be great variations in the relative proportions of leaf, leaf-sheath, petiole, stem and inflorescence. In immature grasses, stems tend to be more digestible than leaves, but their decline with advancing maturity is more rapid than in leaves (McDonald 1968; Lambourne and Reardon 1962; Pritchard, Folkins and Pigden 1963; Terry and Tilley 1964). Terry and Tilley (1964) determined the in vitro digestibilities of leaf-blade, leaf-sheath and stem fractions of the grasses cocksfoot, perennial ryegrass, timothy and tall fescue and the leaves and stems of lucerne and sainfoin. Results showed that all parts of the plant had a high digestibility at early stages of growth. With maturity in grasses the digestibility fall off of leaf-sheath is intermediate in rate to leaf and stem.

2. Species: Demarquilly and Jarrige (1973) measured higher digestibility values in legumes than in grasses. They noted that the legume leaf values were high and practically did not change with age. Lancashire and Ulyatt (1974) compared the liveweight gain of young sheep set stocked on browntop (Agrostis tenuis) and Grasslands Ruanui perennial ryegrass (Lolium perenne) pastures during the main periods of pasture growth over two years. During spring there was no difference between the liveweights of sheep grazing the two pasture types, but in early summer although flowering was suppressed by grazing, the relative higher liveweight gains on ryegrass were attributed to greater stem and stolon development and poorer leaf growth in the browntop pasture. Levy (1970) mentions that the feeding value of browntop will be reduced very rapidly if it is allowed to become long and rank, particularly during the flowering period over the summer. At the same age, or with the same proportion of leaves, perennial ryegrass is more digestible than cocksfoot, because it has more digestible cell walls and contains more soluble carbohydrates (Jarrige and Minson 1964).

3. Varieties: Comparing the feeding values of ryegrasses, by measuring liveweight gain of sheep grazing them, Ulyatt et al. (1974) found that the annual ryegrasses consistently proved of higher feeding value than perennial ryegrasses. As mentioned earlier these differences have been shown to be due partly to higher herbage intake of the annual ryegrasses and partly to their higher nutritive value (Ulyatt 1971; Ulyatt and MacRae 1971).

4. Maturity: The digestibility of grasses and clovers decreases with advancing maturity, but this is not a uniform progression; each variety tends to have a characteristic relationship between digestibility and stage of maturity (Minson et al. 1964; Harkess 1963). The decline of digestibility is associated with a reduction in the content of water-soluble and protein constituents in the plant, and with a reduction in the digestibility of fibre (Terry and Tilley 1964). The decline commences in grasses about the time that the inflorescence stems start elongating, and builds up to a maximum when the seeds are ripening (Smetham 1973).

Pritchard et al. (1963) observed that the earliest maturing grasses tended to be higher in in vitro dry matter digestibility (IVD) than the other grasses at the flowering stage. The decline in IVD as the season progressed was observed in all portions of the plant, the rate of decline for the heads and stems being greater than for the leaves. The upper segments of the stems tended to have a lower IVD than the basal segments.

Demarquilly and Jarrige (1973) state that the proportion of cell walls in the stems and their degree of lignification increase with age in both legumes and grasses.

C. Management Digestibility of pasture can fall to low levels at maturity, with poor management systems. Smetham (1973) notes that periodic or continuous grazing continually return the pasture components to a physiologically young stage of growth. Where grazing is rotational it is important to keep the spelling interval over the mid-summer

period as short as possible. He further adds that achieving good utilization is probably the most difficult aspect of grazing management.

D. Stocking Rate The digestibility of the diet and of the residue pasture is affected by stocking rate, through its influence on sward availability and structure. Higher stocking rates have been shown to increase utilization, providing regrowth of higher quality and thus more digestible diets (Chacon, Stobbs and Dale 1978; Harkess, de Battista and Dickson 1972). However, Langlands and Bennett (1973b) state that the effect of rainfall, and thus pasture growth, influences the effect of stocking rate on the digestibility of the diet. In a low rainfall situation, with sheep grazing Phalaris tuberosa-Trifolium repens pasture, digestibility of the diet decreased by 4 units for an increase in stocking rate of 20 ewes/ha. At high stocking rates availability of dry forage was low, selective grazing was not possible and sheep consumed any material available. At low stocking rates ample dry forage was available, selective grazing operated, and the digestibility of the diet and stocking rate was negatively correlated.

In other years, (unpublished observations) when rainfall was high, a short green sward developed at high stocking rates, while at lower stocking rates, the green material was present but was diluted by dead forage which had not been consumed in previous years; this appeared to impair the ability of sheep to select green material of high digestibility.

E. Environment Prolonged hot and dry conditions can cause a substantial reduction in digestibility, particularly when herbage is wilting for long periods.

SECTION 2

I METHODS OF DIET EVALUATION

A. Introduction The following review will highlight methods, associated with field grazing trials, for the measurement of parameters associated with the diet selected by the grazing animal. Emphasis will be on measurements of diet selection and the quality of this diet.

B. Selectivity 1. Observation: Cook, Blake and Call (1963) observed the grazing of fistulated sheep and cattle on rangeland. Observations were recorded for plant units consumed for each major plant species by each species of animal.

Cockayne (1919) considered relative palatability knowledge as being fundamental to any scheme for improving pastures. He ranked plants for palatability on a scale of 0-5.

Bartlett (1958) rated palatability by the difference between utilization of a plant and the average utilization of all plants on the range. Recognizing the influence of availability on forage preference, he computed the palatability index for high, medium and low availability classes of plants, which were examined independently.

Van Dyne and Heady (1965) developed a relative preference index which allowed all availability classes

to be considered simultaneously. Their index was a ratio of the percentage of a plant in the diet to the percentage availability of the plant. This index was modified by Chamrad and Box (1968) to include frequency of occurrence of a plant in the diet.

Diet frequency measurements can be important in determining relative preference of animals for specific plants because the index then includes not only the quantity of a plant the animals eat, but also the consistency with which they select the plant. However consistency of selection may be influenced by plant distribution (ie. uniformly distributed plants might be more frequent in the diet than plants with irregular distribution). Allowance can be made for this by using frequency of the plant on the range as a part of the availability factor (Krueger 1972).

Petrides (1975) has defined a "preferred food species" as one which is proportionately more frequent in the diet of an animal, than it is in the environment; and "food preference" as the extent to which a food is consumed in relation to its availability. He suggested the use of a preference index which is the ratio of the percentage of a species in the diet to the percentage availability of that species. He has termed foods which are eaten in greatest quantities by an animal population as "principal foods". These are foods which form the greatest proportion of the animals diet. A principal food is not necessarily a preferred food.

Scott and Maunsell (1974) assessed the ten most abundant species on developed and undeveloped tussock

blocks at two-monthly intervals, at sample points along set transects. The advantage of the ranking method is that it is easier for an observer to decide whether one species is more abundant than another at a particular sampling than to estimate independently the abundance of each. This method has been successfully used by others in a similar environment (Hughes 1975; Stevens 1977), while Hercus (1963) and Stevens (1977) randomly threw a 30 cm diameter ring with all species within the ring being recorded and each rated according to its degree of defoliation.

2. Plant Measurements: The point analysis method was developed and described by Levy and Madden (1933), and its limitations and uses by Sears (1951) and Round-Turner (1972). It has been used successfully by many to estimate the botanical composition of pasture (Lynch and Mountier 1954; Lynch 1966; Korte 1973; Stevens 1977).

Evans and Love (1957) developed a step-point sampling method which provided a rapid, accurate and objective method of determining botanical composition and total cover of herbaceous vegetation. A rod or the cross bar of a frame, is aligned with the notch on the toe of the boot after pacing to random positions.

Hodgson and Ollerenshaw (1969); and McIvor and Watkin (1973) studied the frequency and severity of defoliation of individual tillers and leaves in set stocked swards. Methods used for identification of tillers include coloured marker rings, lipstick and cellulose paint, or as used by Morris (1969) a relocatable grid.

3. Hand Plucking: Langlands (1974) found that hand plucking of herbage to resemble grazing, overestimated nutritive value at high levels of digestibility and nitrogen content, and underestimated nutritive value when this was low (eg. on poor quality native pastures). Sheep grazing native pastures were able to select green material from amongst the large bulk of dead material available, but Langlands (1974) found this difficult to simulate by hand plucking.

Thus the method has limitations but reliability can be improved by operators being familiar with normal diet samples, such as those obtained in the same environment from oesophageal fistulated animals (Langlands and Holmes 1978); and plucked material be a composite sample obtained by a number of operators working independently (Langlands 1974).

4. Faecal Cuticle: The structure and arrangement of the epidermal cells are characteristic of the species, and thus the pattern discernable on the cuticle is also characteristic (Crocker 1959). The cuticle covering the actively growing tissue of the leaf meristem is very thin and readily disintegrates on maceration so that only cuticle from mature tissues is likely to survive the processes of digestion.

The thickness of the cuticle varies from species to species; some have thin cuticles that do not survive chemical maceration, and are unlikely to survive digestion, so there will be no identifiable traces of these in the faeces (Crocker 1959). In this instance she uses the example of sweet vernal (Anthoxanthum odoratum) although

Stevens (1977) would refute this argument concerning sweet vernal, claiming experimental technique was the problem. Slater and Jones (1971) in examining the faecal cuticle technique, could not detect any epidermis of white clover in known mixtures. They therefore concluded that the epidermis of white clover was destroyed or so changed as to be unrecognisable in the faeces; a conclusion which differs from the results with white clover obtained by Hercus (1960).

Fresh leaves and stems are collected from known plants and the cuticle separated by chemical treatment, stained and mounted. Diagrams and photographs of the cuticle pattern, together with reference slides, form permanent references.

The advantages of the faecal cuticle identification method are that it does not interfere with the normal habits of the animal, as may occur with the use of harnesses and fistulas, and it imposes no restriction on the movement of the animals (Crocker 1969; Hercus 1960; Hughes 1975). It is of particular value where the animals range extensively over mixed communities, such as the tussock grasslands (Crocker 1959; Stevens 1977).

There have been attempts to improve the method from a qualitative analysis to a quantitative analysis. However Heady and Van Dyne (1965) and Theurer (1970) report that weight per unit area of epidermis is not consistent at different stages of maturity, or for all species.

5. Rumen Fistula: The use of the rumen fistula for dietary analysis, involves the clearing of the rumen before the animals are allowed to graze. This requires a rumen fistula large enough to permit the insertion of the hand and arm to remove the contents of the rumen. Immediately after the sample of ingesta is removed from the rumen the original contents are placed back into the rumen so that the animal is not deprived of its rumen microorganism population (Cook 1964).

The effect of an empty rumen on selection of plant material or plant species is not known (Theurer 1970).

6. Oesophageal Fistula: (a) Introduction:

Although the actual accuracy of oesophageal fistula sampling can not be determined because "true" grazing samples are never available, Van Dyne and Torell (1964), who reviewed the development and use of oesophageal fistulation, are of the opinion that samples collected in this manner yield the best available estimation of the qualitative intake of grazing animals. Many other researchers share this view (Van Dyne and Heady 1965; Laycock, Buchanan and Krueger 1972; Stobbs 1973; Hamilton et al. 1973; Arnold 1964, 1970).

(b) Surgery: Essentially the oesophageal fistulation technique calls for a skin incision in the mid-cervical region on the left side between the sterno-cephalic and omohyoid muscles; exposure and incision of the oesophagus, and suturing of the mucosa and muscular tunic to the skin margin (Moule 1965). Closure is affected with rigid plastic cannulae, or latex or rubber plugs of various designs.

Optimum size of the fistula appears to be about 6 sq. cm (McManus, Arnold and Hamilton 1962; McManus 1962). Above this size difficulties associated with keeping stoppering devices in position when the animal is not being used outweigh any advantage of larger samples of extrusa (McManus et al. 1962). Control of leakage is a major difficulty because continued loss of contents during regurgitation leads to digestive dysfunction, and the loss of saliva causes dehydration.

A split plug stopper for oesophageal fistulae minimizes damage to the tissues surrounding the fistula on insertion or removal, and it gives substantially improved closure of the fistula than a solid-stemmed latex stopper (McManus et al. 1962).

Successful surgery can vary, with McManus (1962) reporting a low 14% successful total out of 35 sheep; and Hamilton (pers comm) 95% successful.

(c) Animal Behaviour: The value of measurements on samples collected from oesophageal fistulae will depend on two important criteria. Firstly that sheep with fistulae should behave and function in a normal way and secondly that the sample collected from the fistula must give a reliable estimate of the sheep's diet. Arnold, McManus, Bush and Ball (1964) found that liveweight changes, wool growth, grazing time and estimated herbage intake did not differ significantly between fistulated and non fistulated sheep.

Langlands (1975) emphasised the desirability of having fistulated and normal animals similar with respect to age, breed and previous grazing experience, if it is to be assumed that fistulated and unfistulated animals select similar material.

Langland's (1967) results showed that the composition of the material collected from fistulated sheep varied with the previous environment of the sheep. Arnold, Ball, McManus and Bush (1966) suggested that atypical material would be consumed if sheep grazed unfamiliar pasture. Arnold (1964b) found that sheep with different grazing experience in the first three months of life, showed different preferences when presented with the same choice. The differences disappeared more quickly for the generally liked species (eg. Lolium perenne, Dactylis glomerata) than for the generally disliked species (eg. Stipa myaliva - a spear grass). Older animals have been reported to adapt to unfamiliar plants less readily than younger animals (McBride, Arnold, Alexander and Lynch 1967).

In contrast to earlier evidence from Australia, recent studies at Hurley have shown that fistulated animals can give representative samples of extrusa as soon as they start grazing a sward to which they are not accustomed (Hodgson and Rodriguez (1970). They continue by saying that the opportunity for within sward selection is likely to be smaller under Hurley conditions than in Australia. However there are important differences between animals in the composition of samples of extrusa and some of the differences in extrusa composition. This is attributed, by the Australian workers, to differences in the degree of experience of a sward; but may have been due to real between-animal variations.

In a series of preliminary trials, Hodgson (1969) found that the between sheep variations in the composition of extrusa samples were usually greater than the systematic

effects of fasting, experience of a sward and sampling time, on diet selection.

Diurnal variation in the quality and composition of the diet have frequently been recorded (Langlands 1967; Heady 1964a; Hodgson and Rodriguez 1970). Heady (1964a) attributes the differences in dietary composition between morning and afternoon grazing to differences due to hunger after the nights fast, to changes in moisture content of the herbage during the day, to temperature changes, to other conditions, or to a combination of factors.

From indoor trials, Hodgson and Rodriguez (1970) suggest that there is strong evidence of a direct relationship between the nitrogen content of the extrusa and the weight of saliva added per unit of extrusa collected. This may explain the evidence on diurnal variations in the concentrations of nitrogen in extrusa. Saliva is secreted continuously so that the amount of saliva collected per unit weight of extrusa dry matter increases as the rate of feed intake declines. The rate of herbage intake is likely to be high during intensive periods of grazing in the morning and evening, and low during desultory grazing in the middle of the day, resulting in a higher rate of addition of saliva per unit weight of herbage eaten (and therefore a higher nitrogen concentration where the concentration of nitrogen in saliva dry matter is greater than that in feed dry matter) at midday than in the morning and evening. Variations in the composition and rate of secretion of saliva are basic problems in the use of fistulated animals. Lambourne (1965) notes that continuous slight loss of saliva gives

oesophageal fistulated animals a marked appetite for salt and this could effect their grazing preference under range conditions. They may also tend to select moist rather than dry feed in arid conditions, because of their chronic moisture loss.

Peel and Wilson (1964) concluded that the diversion of two litres of saliva over a five hour period had little effect on the oesophageal fistulated sheep provided the sodium loss was subsequently restored.

Fasting is thought to stimulate the animals appetite due to a low rumen content (Arnold, McManus, Bush and Ball 1964), and cause differences in preference for dietary material (Heady 1964a).

Langlands (1969a) notes that young animals losing temporary incissor teeth, may be unwilling to select coarse material or to graze as close to the ground as adult sheep.

(d) Extrusa Collection: Saliva contamination of extrusa samples affects the digestibility result of the diet sample. Langlands (1975) states that if this saliva contamination is ignored, then the digestibility of the diet is over estimated by approximately 1-2 units. If the liquid fraction, of a bag collected sample, is discarded on the assumption that it is of salivary origin, digestibility is under estimated by 3-4 units. Robards and Wilson (1967) showed that washing pasture samples collected from the oesophageal fistula of grazing sheep reduces their apparent digestibility by an average of 7.0 digestibility units. Langlands (1966) has shown that saliva can increase

apparent digestion by 1.6 units. Thus, it is apparent that the remaining 5.4 digestibility units would be due to loss of soluble plant material and fine particles during washing.

Loss of soluble plant material due to washing is likely to decrease with increasing maturity of the plant material. It is also likely to vary with the extent of mastication by the animal (Grimes, Watkin and May 1965). However, loss of soluble plant materials is likely to be similar in grasses at the same stage of maturity (Robands and Wilson 1967).

Hodgson and Rodriguez (1970) note that errors of digestibility on extrusa may arise if the samples of extrusa are subjected to fermentative changes after collection or to heat damage on drying.

Recoveries of ingested material in the extrusa may be low when long roughages are consumed and the fistula is small or badly positioned (Langlands 1975). This may result in the extrusa being unrepresentative of the material consumed. This problem can be alleviated by inserting a foam rubber sponge into the lower oesophagus when sampling. Another problem is that animals may be unwilling to graze during daylight hours in hot weather (Langlands 1975).

The length of sampling time is normally determined by the time taken by the fistulated animals to obtain a workable sample, which is obtained generally in the vicinity of 20-40 minutes in temperate environments (Arnold, McManus Bush and Ball 1964; Leigh and Mulham 1966) and up to two hours in more extensive grazed systems (Wilson, Weir, and Torell 1971). McManus (1962) infers

from his data that probably collection time should not exceed one hour in order to maintain normal conditions in the rumen.

Sample collection apparatus varies from harnessed canvas bags (Torell 1954), some with gauze bottoms to allow free saliva to drain (Arnold et al. 1966), to water tight polythene bags secured around the neck with spring clips (Langlands 1966). Other discard the use of collection bags for various physical and practical reasons and collect extrusa off the ground (Stevens 1977, Alder 1969).

(e) Extrusa Analysis: Methods of extrusa dissection vary depending on the sample characteristics and the type of analysis required. Arnold, McManus, Bush and Ball (1964) separated extrusa subsamples by hand into grass, legume, weed and inert fractions. With care it was found that very little of the material was unrecognisable. Stobbs (1969) lightly washed his extrusa samples, obtained from oesophageal fistulated cattle grazing a two species sward, to remove saliva. After thorough mixing, ten subsamples of 10-12 grammes were placed on petri dishes and separated by hand into their grass and legume fractions. Taylor and Deriaz (1963) separated herbage ingesta samples into constituent morphological parts, aided by gently drying the thawed sample with a current of warm air. Samples were separated into green and dead categories of 'leaf', 'leaf-sheath' and 'flowering stem'.

Chacon, Stobbs and Haydock (1977) stored their extrusa samples at a temperature of -10°C . Later three sub-samples

of this frozen mass were floated in petri dishes, and manually separated with forceps into leaf, stem and a residual fraction with fragments too small to be positively identified. This residual fraction was scored on the basis of 1 to 10 for leaf content under the field of a 15 x binocular microscope. The residue varied from 7 to 27% of the total dry matter sample and was higher for grasses than legumes and highest on diets containing the greatest content of stem. They concluded that the accuracy of their technique would be improved by careful mixing and sampling either of extrusa before freezing or of the thawed extrusa prior to separation, by separating a larger sample or by separating a larger number of smaller samples.

Variations of a microscope point technique have been widely used for analysis of oesophageal fistulated extrusa samples. With the microscope point technique, extrusa samples are spread out on a tray and passed under a binocular microscope equipped with a crosshair and a stage with established stops. The plant or plant cuticle appearing immediately under the crosshair is identified and recorded at each point location, and can be checked against standard slides or photographs.

Galt et al. (1968) assessed 400 microscopic points per sample with unidentifiable material ranging from 3.1 to 19%. This material was largely attributed to being plant material destructed by mastication.

Harker et al.'s. (1964) results with hand clipped forage of known weight indicated that 400 points were necessary to obtain sample means for the major species within 10% of the

population mean with 95% confidence. Four hundred points estimated percentage dry matter at 90% confidence limit to within 20% of the mean if the weight is 16 to 30%, to within 10% of the mean between 30 and 50% weight, and to within 5% of the mean from 50 to 95% weight, in a two species sward.

Heady and Van Dyne (1965) reported that ratios of weight to points changed during the growing season because of changing thickness of plant parts, shattering, and varying proportions of plant parts. Serious errors in estimating botanical composition of the diet could occur if the stage of maturity of plant species used to determine the regression equations, for predicting species composition quantitatively, differs from that of the species consumed.

Hamilton and Hall (1975) achieved results at variance with known diet compositions of legumes and grasses, using the microscope hit method. The legume content was consistently underestimated by up to 23%. Much of this underestimate was attributed to the weight per unit area of the leaves of the legume being approximately twice that of grass leaves. When the microscope hits were adjusted for the weight per unit area of each of the plant components (leaves, petioles, flowers and seed pods) the relationship between the estimated and actual legume consumed was improved; the greatest difference between actual and estimated legume being approximately 5%.

Hall and Hamilton (1975) found the microscope point technique, when adjusted for the weight per unit area of each plant component, more accurate than manual separation.

Free, Sims and Hansen (1971) compared the "microscope technique" with a "bite count" method for estimating dry-weight composition of plant species in the diets of steers grazing sandhill range in eastern Colorado. They concluded that reliable results are highly dependent upon the observer. In the case of the "bite count" method, the observer must be able to identify individual species of plants in all growth stages at distances of up to 3 metres. One advantage of the "bite count" procedure is that it does not require fistulated animals, but does require quiet animals.

C. Quality 1. Digestibility: The digestibility of harvested forage can be determined directly by the so called "conventional method" (Streeter 1970). Confined animals are fed the forage for several days and measurements are made of feed consumption and faecal production. When a pasture is grazed by one group of animals and cut and fed to another group in pens, differences in intake may occur. The grazing animal is able to select specific plant parts and plant species. Confined animals are usually fed equal quantities of feed at regular intervals whereas grazing animals forage throughout the day and night. Arnold (1970) states that the cutting of herbage alters its odour, since odours of plant juices are released. He also notes that the intakes of grazing animals may be higher than that of housed animals because of changes in feed acceptability, and energy demand is higher, and digestibility higher.

Streeter (1970) reviews three indirect techniques which have been used to estimate the digestibility of grazed forage.

Ratio techniques depend upon the ability to obtain representative samples of faeces produced and forage consumed. Faecal samples can be total collections with bags or direct rectum samples which rely on a consistent or reproducible concentration of the internal indicator in the faeces throughout the day so that the composition of the faecal samples represents that of the total faecal production, or a diurnal concentration regression has previously been obtained.

Daily and diurnal variation in the concentration of the internal indicator in dietary samples could also lead to biased, and/or variable estimates of digestibility (Langlands 1965, 1967a; Van Dyne and Heady 1965). Random daily variation can be accounted for by collecting samples for several days and utilizing the average daily indicator concentration. Biased results are obtained with the ratio technique when faecal recovery of the internal indicator is anything but 100%. Faecal recovery is, therefore, a useful means of expressing bias and variability associated with this technique. The indicators commonly used are iron, silica, chromogen and lignin.

Faecal index techniques were developed by workers who questioned the reliability of obtaining representative dietary samples by hand clipping (Raymond 1954). The method involves the prediction of digestibility from the composition of the faeces. It assumes that the faecal index relationship is the same for forages selected by grazing animals as for forages fed in the conventional digestion trial from which the faecal index relationship was developed. It also assumes that the digestive capacity of the animals

on pasture and the animals which were hand fed must also be the same.

Faecal nitrogen index regressions have been found to vary significantly with the season of the year (Minson and Raymond 1958). Lambourne and Reardon (1962) stated that this seasonal bias was an artifact of differences in the leaf:stem ratios between the herbage clipped for conventional digestion trials and that actually consumed by grazing animals. Apart from nitrogen, common indices also include chromogens and methoxyl groups.

Micro digestion techniques have been developed for the analysis of digestibility of small herbage samples. The nylon, silk or dacron bag technique permits the study of small samples of forages in the rumen and the estimation of their digestibility, by difference in weight after a time period (Chenost, Grenet, Demarquilly and Jarrige 1970). However Scales, Streeter, Denham and Ward (1974) in comparing various indirect techniques for estimating digestibility, did not consider the nylon bag technique to be a valid estimation of in vivo digestibility.

Tilley and Terry (1963) devised a simple technique for the determination in vitro of the dry or organic matter digestibility of small samples of dried forage. 0.5 g of dried, ground forage is incubated for 48 hours, firstly with strained rumen liquor and a phosphate bicarbonate buffer and then for 48 hours with acidified pepsin. The residue after these two successive incubations is then weighed and the digestibility of dry matter estimated as the dry matter lost or rendered soluble as a percentage of

the 0.5 g of dry matter of the initial sample. The regression equation relating dry matter digestibility (DMD) determined with sheep (in vivo) and DMD determined in vitro by the procedure on 147 frozen forages was:-

$$\text{DMD } \underline{\text{in vivo}} = 0.99 \text{ DMD } \underline{\text{in vitro}} - 1.01 \pm 2.31$$

McLeod and Minston (1969) considered that the in vitro digestibility of tropical grasses could be accurately predicted by in vitro digestibility provided the procedure was standardized and samples of known in vivo digestibility similar to those being tested are included in each run. Their results showed that in vitro digestibility was affected by fineness of grinding, sample size, pH of original rumen fluid and size of rumen fluid inoculum.

Newman (1974) discusses how the in vitro digestibility technique has overcome the need for laborious feeding trials in the preliminary assessment and comparison of pastures. The technique is applicable to a wide range of pasture species provided always that test runs are standardized with samples of known digestibility in vivo.

Troelsen and Henel (1966) state that duplication of a biological process in vitro is recognized to be a precarious task, and it is no surprise that many of the problems associated with in vitro digestibility determinations have been related to the viability of the rumen microflora. Clark and Mott (1960) concluded that in quality comparisons among forage lines, samples of all lines should be digested with the same batch of rumen fluid. Baumgardt, Taylor and Cason (1962) recommended that a standard forage be included in each trial to facilitate adjustment for day to day variability among trials. Troelsen and Henel (1966)

observed differences in microbial viability of the rumen liquor between days. They suspected it might have been caused by the consumption of water at varying time intervals prior to collection of rumen liquor resulting in different inoculum dilutions.

Terry, Mundell and Osbourn (1978) highlight the expensive nature of supplying rumen liquor for in vitro digestibility analysis. The success depends on the availability of a supply of rumen liquor of constant enzymic activity.

Roughan and Holland (1977) being aware that not all analytical laboratories could maintain animals for the sole purpose of providing an appropriate rumen liquor for the established in vitro technique, developed a cellulase digestibility method. Cellulase digestibility, defined as the percentage of whole, dry plant material solubilized by neutral-detergent extraction followed by exhaustive hydrolysis with standardised cellulase, was highly correlated with in vivo dry matter digestibility (DMD) ($r=0.98$), and predicted the parameter with reasonable accuracy (residual standard deviation = 2.83). The form of the regression equation was in vivo DMD = $0.98 \times$ cellulase solubility - 10.12, suggesting that the same factors limited cellulase and in vivo digestibility. The method was simple and reliable and results were known within 48 hours.

2. Nutritive Value: The feeding values of many pastures species commonly sown in New Zealand have been evaluated in terms of liveweight gain of sheep (Ulyatt 1970;

Ulyatt 1971; Ulyatt and MacRae 1971; Ulyatt 1969; Lancashire and Ulyatt 1974).

Blaser, Hammes, Bryant, Hardison, Fontenot and Engel (1960) evaluated top, bottom and whole plant grazings. The relative liveweight gains of steers were 100, 118 and 79 in one experiment when restricted to whole plant, top and bottom herbage, respectively.

CHAPTER 2

EXPERIMENTAL OUTLINE, METHODS AND SCHEDULE

I OUTLINE

A. Introduction The objective of this experiment was to measure the dietary selection of sheep rotationally grazing a mixed species pasture, over a period involving large differences in both quality and quantity of pasture available. The influence of stocking rate on pasture utilization and quality, was considered relevant to factors affecting diet selection.

B. Site description The experiment was conducted during the Summer and Autumn seasons of 1977/78, on an area of the Department of Scientific and Industrial Research Hill Country experimental station 'Ballantrae', known as "terrace 3" (Plates 1,2). 'Ballantrae' is located in the south-eastern foothills of the Ruahine Ranges just above the Manawatu Gorge. The Ballantrae 1 meteorological station is located at Latitude $40^{\circ} 18'S$ and Longitude $175^{\circ} 50'E$. The site was a uniformly flat terrace.

Soil type of the experimental area is classified as Ashhurst silt loam, mottled phase (Cowie unpubl.). The mottled phase being due to imperfect drainage. The topsoil consists of dark brown silt loam, friable with a moderately developed medium nutty structure with a distinct boundary at approximately 20 cm depth. Stones are prominent in the subsoil. The nutrient status of the soil is medium with a pH of 5.5 increasing to 6.6 down the profile (Cowie unpubl.).

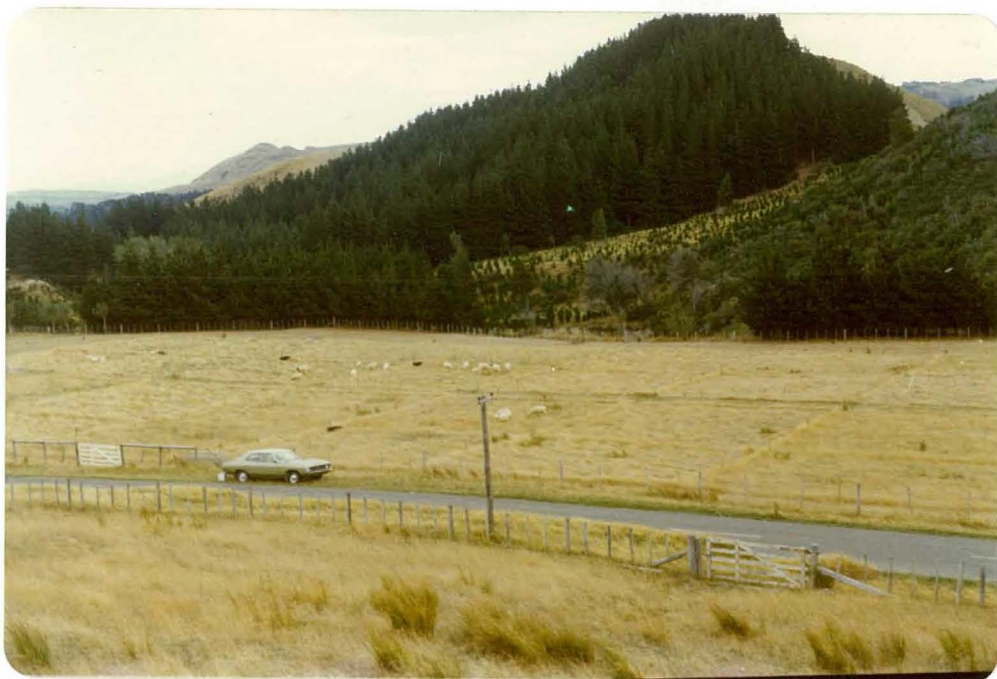

PLATE 1. Experimental overview - late summer
(6-3-78)



PLATE 2. Experimental overview - autumn
(6-4-78)

Fertilizer application has been moderate and consistent since 1969, with annual dressings of 250 kg/ha of superphosphate, except in 1975, when an additional 625 kg superphosphate, 50 kg nitrogen and 1250 kg lime per hectare were applied above the basal application of 250 kg/ha of superphosphate. Pre-1969, fertilizer application was considered to be limited although nutrient status should have been improved due to the accessibility of the paddock to the woolshed and associated facilities, and its use as a "holding paddock".

The experimental area was tile drained (March 1974) and moled (March 1976).

The pasture sward can be described as a very mixed association of species, mainly Lolium, Agrostis, Poa, Holcus, Anthoxanthum and Cynosurus spp. Specific estimations of the sward composition are presented in the data.

C. Experimental design Female Romney yearling (two-tooth) sheep were randomly assigned into two groups of equivalent stocking rates per hectare of 36 and 24. These stocking rates consisted of 6 sheep per plot for the higher (H) treatment, and 4 sheep for the lower (L) treatment; both treatments being replicated twice. Oesophageal fistulated sheep of similar condition, age and experience constituted 3 per replicate of these sheep in the Summer period, and 2 per replicate in the Autumn experimental period.

These sheep rotationally grazed four paddocks per replicate in their separate replicated groups, with two

grazing periods of three days duration per paddock (ie. each paddock was subdivided in half). This grazing management programme resulted in rotation lengths of twenty four days. Three rotations per season were measurement rotations, with one grazing period per rotation being subjected to an intensive measurement programme.

All sheep were identifiable by their coloured numbered plastic ear tags.

The experiment commenced when the animals were allocated to the treatments on 23-11-77 and terminated on 27-5-78.

D. Experimental layout Paddocks and paddock grazing order in the rotation, were randomly distributed to the two treatments (Fig. 1). Each paddock was 14 m x 30 m, and thus an area of 0.042 hectares. Because of paddock subdivision, each "3 day" grazing area was 14 m x 15 m and 0.021 ha in area. The total experimental area involved was 0.672 ha. It was important in the laying out of this trial to provide a uniform site, as free as possible from influences that could interfere with the behaviour of the experimental animals, and the pasture growth and composition. These influences include: distance from a major road, trees, and boundary fences; uniformity of slope, aspect and botanical composition; ease of animal management; avoidance of stock camps and fertility transfer.

The treatments were randomised, by computer, for treatment and order in the grazing rotation. (Fig. 1).

FIGURE 1 EXPERIMENTAL AREA

KEY

- L 4 = Treatment paddock no.
- ▲ = Pine tree
- ★ = Power pole
- = Water pipe
- △ = Gate valve
- = Water trough
- = Trial paddock fence
- = Gate

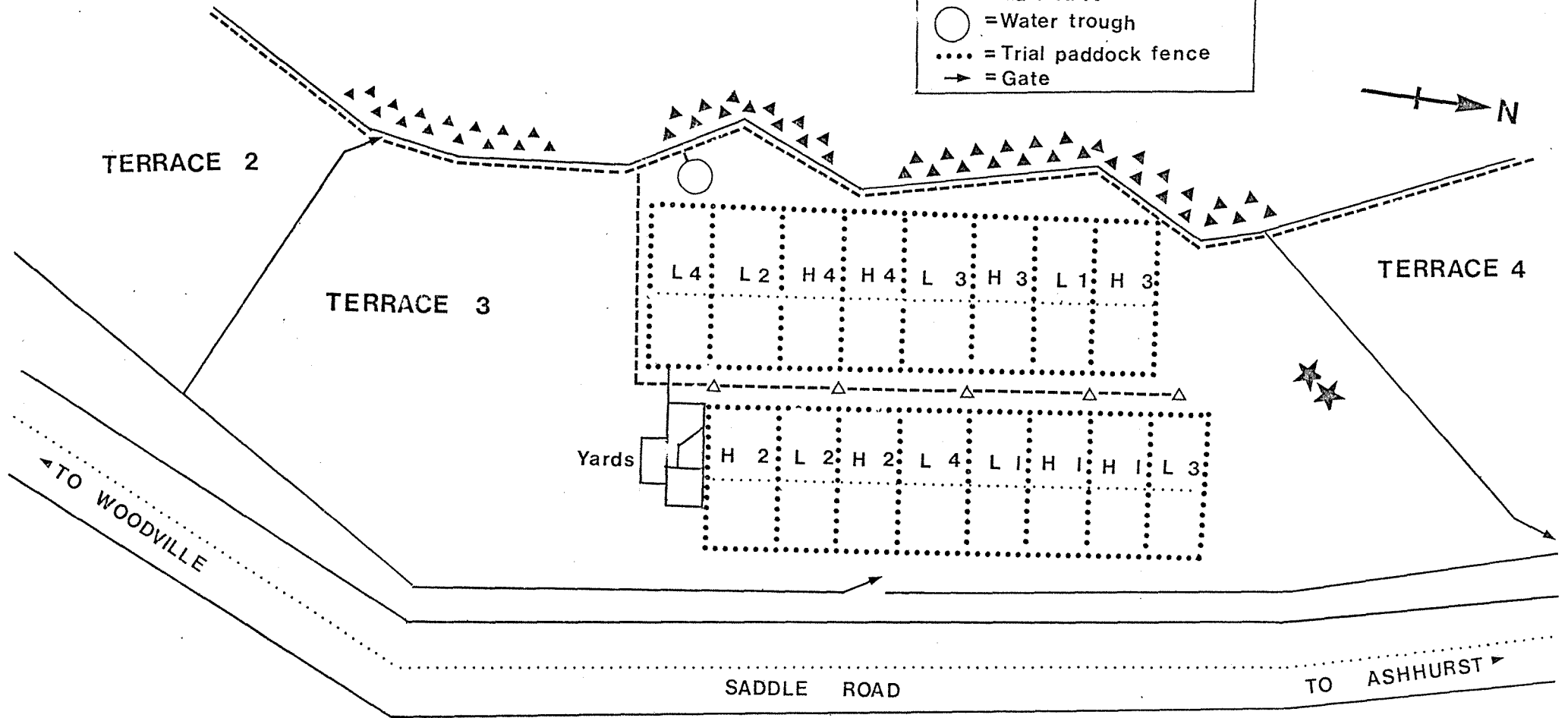

All of the plot fencing was effected by using live-wire strand electric fence wire, battens, posts and grassfence insulators. Three wires, horizontally attached to the battens, and posts by insulators, were used on the treatment boundaries. Two wires were used in a similar manner on the paddock sub-divisions (Plate. 3).

The layout used provided a central race with access to all paddocks off this race. A set of steel, transportable yards, with a race and drafting facilities were positioned at one end of this race.

The power supply for the electric fencing was provided from a mains electric "Grassfence" 5000 volt unit.

Water was provided to all plots. Plastic troughs (130 litre capacity) were used, with twenty metres of hose attached to gate valves strategically positioned along an arterial branch of the main Ballantrae water supply. (Plate 4).

Rock salt was provided in pastic punnets for the sheep in each of the grazing plots (Plate. 4).

E. Animal health and management In a small paddock experiment such as this it is important that the behaviour of the animals is normal. This is particularly relevant when using oesophageal fistulated animals for measuring dietary parameters. Management factors employed to prevent abnormal behaviour from occuring included: unlimited access to rock salt for the oesophageal fistulated animals; an available water supply; regular drenching with anthelmintic; prevention of fly strike through neck crutching and dipping; and trimming of overgrown hooves.



PLATE 3. Paddock subdivisional electric fencing,
and an oesophageally fistulated ewe.

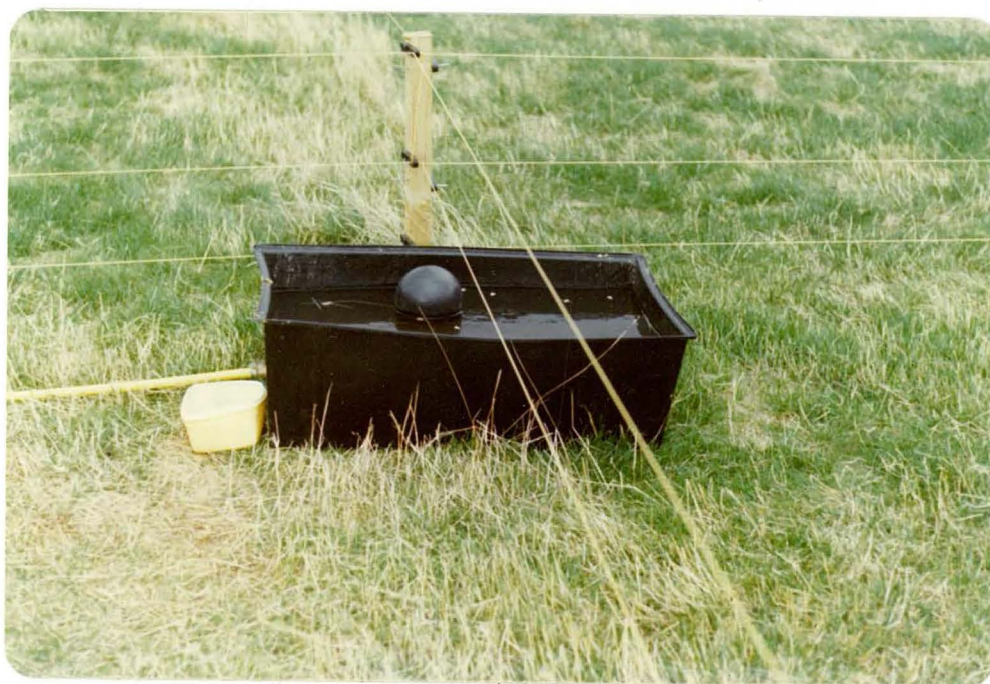

PLATE 4. Water supply equipment and rock salt
plastic punnet.

Close observance of the fistulated animals is essential in preventing blockages of the oesophagus, generally caused by coarse material, and in ensuring cannula size is sufficient to prevent excessive saliva loss.

Methodical and careful animal handling is essential.

II EXPERIMENTAL METHODS AND MEASUREMENTS

A. Pasture sampling Pasture parameters were measured to give a description of pasture types and characteristics. Intensive sampling was undertaken at each of the measurement grazing periods. Eight random 0.2 m^2 quadrats (400 mm x 500 mm) were cut before, after and once during the 3 day grazing period being measured.

It was necessary to avoid sampling atypical pasture material around the perimeter of each plot. This pasture material was atypical due to a low grazing intensity, reflecting the animals "fear" of the electric fence, and a similar low intensity of animal behaviour in this narrow perimeter strip. Because the pasture quadrats were cut close to ground level (0.5 cm above ground level), pasture sampling was considered to be not possible on the same plot in any one season. This was decided due to any influence of these quadrats having on modifying the grazing behaviour of the animals, and of overlapping of pasture sampling.

Random co-ordinates (ie. pairs of numbers) using the numbers 1 to 13 were obtained by computer print out. As the plot size was 14 m x 15 m, these co-ordinates ignored a one metre strip down three sides of the plot and two

metres down the fourth side. The reference corner of the plots, was changed in a clockwise direction for each of the three pasture samplings per 3 day grazing measurement period. Eight of these paired co-ordinates were used, per measurement, being paced (1 pace = 1 metre) from the reference corner and the 0.2 m² quadrat aligned with the centre of the boot, in the longitudinal axis of the quadrat (Evans and Love 1957).

Hand shears with turned up handles, and sides (Plate. 5) were used to harvest these pasture quadrat samples. The pasture material on harvesting was placed in plastic bags and sealed. This reduces moisture losses, respiration losses, bacterial infection and tissue breakdown (Boswell undated).

The philosophies of Green (1949) and Van Dyne, Vogel and Fisser (1963) were considered in determining the size of quadrat sample to be taken and its shape. Practical aspects of the number of samples possible to handle, sward variability, and sampling influence on animal behaviour were equally important.

(1) Pasture availability and Residue Pasture quantity was measured from dry matter determinations on the bulking of the eight 0.2 m² quadrat cuts. The eight quadrat samples per replicate per cutting were weighed (greenweight) and then a 100 gm subsample, obtained by random grabbing, was oven dried in a forced air oven at 80°C for 16 hours, for dry matter determinations. The remaining green material was bulked.

During the summer measurement period, stratified pasture sampling was used. This involved the cutting of



PLATE 5. Hand shears used for pasture sampling

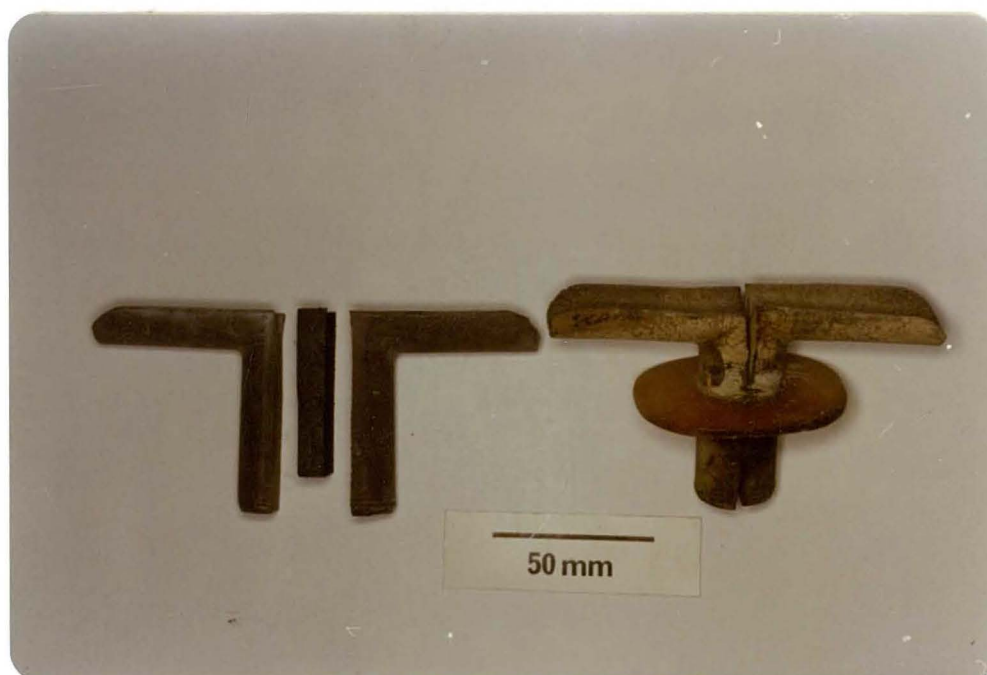

(a)

(b)

PLATE 6. Cannulae plugs used in oesophageally fistulated sheep.

- (a) "Split plug" latex stopper with spacer
 (b) "Split plug" and plastic plate

two strata, above and below 100 mm, and separate dry matter determinations.

During the autumn period, herbage availability was low, and there was no reason to stratify the cuts since all plots had previously been forage harvested to remove the standing dead matter.

By subtracting the post-grazing dry matter residue from the pre-grazing dry matter availability, an approximation of utilization or "intake" can be achieved, by reducing the difference to the area of the plot, rather than per hectare. Similarly per animal utilization can be obtained by dividing the above result by the number of animals present.

(2) Botanical composition Species composition was assessed for each plot per measurement day, on the bulk samples. Grab sampling was used to obtain this bulk subsample, and then this 100 gm (approx.) grab sample was reduced to a workable sample (dependant on number of pieces) by quartering. Analysis was on a dry matter basis following hand separation in species components.

(3) Morphological composition A similar procedure to the above was adopted for obtaining a workable sample. However these samples were preserved, by freezing and then freeze drying, until they could be dissected into components of leaf, stem, dead matter and weed species. Analysis was reported on a dry matter basis. In the summer period, when the pasture cuts were stratified, the morphological dissection was also done on a strata basis. Dissections were performed only on the day 1 and day 3 samples.

(4) Organic matter digestibility Pasture samples were analysed for in vitro organic matter digestibility. The samples were freeze dried; leaf, stem, dead matter and total samples were obtained from the morphological structure analysis. These freeze dried samples were oven dried, and then fine ground using a Krups coffee grinder. In vitro digestibility was estimated via the cellulase method of Roughan and Holland (1978), on day 1 and day 3 samples.

(1) Laboratory Procedure (a) Production of cellulase. Cultures of a Trichoderma selection of strain OM9414 were obtained from Plant Physiology Division, D.S.I.R., Palmerston North, and maintained on the slopes of potato dextrose agar. When required a transfer was made from the slope to a petri dish and kept for seven days at 25°C until the surface was covered with spores. The spores were suspended by gentle agitation in approximately 12 ml of 0.1% Tween 80 (polyoxyethylene sorbitan mono-oleate) and 2.0 ml was used to inoculate 500 ml of a basal salts culture medium. 0.1% Tween 80 was also added to the medium. The cellulose source was 1% cellulose paper powder (Whatman CC31) and the protein source 0.1% peptone.

The cultures were grown in 100 ml low form conical flasks on an orbital shaker at 80 cycles per minute, maintained at 25°C and harvested after 15 days. Solutions were filtered through Whatman No. 1 circles under low pressure, and clear yellow solutions obtained. The enzymes preparation was preserved from contamination with .05% Thiomersal added immediately after filtration.

Culture medium, and Tween 80 flasks used for inoculation were sterilised by autoclaving for 25 minutes at 138 KN/m^2 (20 psi) pressure. Pipettes were wrapped in foil and sterilized in an oven at 160°C for 2-3 hours.

(2) Digestion 200 mg of dried plant material was weighed into culture tubes and 10 ml of hot neutral detergent solution added. The tubes were clamped onto a rotating holder built into an incubating cabinet and incubated at $95\text{-}100^\circ\text{C}$. After 60 minutes the tubes were centrifuged, the supernatant removed and 10 ml of hot water added. Tubes were mixed by rotation for a further 30 minutes at 100°C . Residues were washed twice before the addition of 10 ml of cellulase solution and incubated at 50°C with continuous mixing for 6 hrs. The residues, separated by centrifuging were resuspended in 10 ml of fresh cellulase and incubated for 18 hours.

After centrifuging, the liquid was removed and 10 ml of water added. The residue was collected by filtering through sinta-glass crucibles (No. 1 porosity) and washed thoroughly before drying.

For organic matter digestibilities, the samples were ashed at 500°C in a "Gallenkamp" furnace, for 3 hours.

B. Animal Sampling Dietary samples were obtained by the use of oesophageally fistulated (OF) sheep. In the summer period there were three OF sheep per replicate; and in the autumn two per replicate. It was decided to allow the bolus material to fall on the ground and later to be

collected from there. This was considered necessary in order to avoid animals regurgitating into the collection bags and ruining the sample. This can easily happen in situations where the animals are expected to yield samples at a time which may not totally agree with their normal grazing pattern. Also, the rustle of plastic collection bags can greatly upset the group animal behaviour; as can any collection bag affect the donor animals behaviour if not totally accustomed to such conditions. Saliva contamination to a large degree, is also avoided.

(1) Procedure The OF animals and the normal animals were removed from their replicate plots and bulked in the yards, in treatments. This was normally 3 or 4 hours after sunrise (ie. about 9.00 am). The cannula plugs (Plate 6) were removed and placed in numbered tins to identify the cannulae with their sheep. The animals, in correct proportions of OF: normal sheep, were returned to their new plots (in the case of sampling on the first day) or to their existing plots. Extrusa samples were dropped by the grazing OF animals. Collection time was 20-30 minutes and was terminated by the animals being returned to the yards in treatment groups. The cannulae were cleaned and replaced.

Bolus samples were collected from each plot and placed into a sealed plastic bag per plot and placed into a deep freeze as soon as possible. Extrusa material that was found within the perimeter one metre or on a cut quadrat site was discarded. Sample size collected was normally in the vicinity of 500 to 2000 gms per plot. The extrusa was

thoroughly mixed and a grab subsample of approximately 200 gm net weight was frozen, and then freeze dried for analysis.

The animals were then returned to their plots after the extrusa material was collected. It was important to ensure that all extrusa material was collected so as not to confuse it with collection material on the other days. (Extrusa material was collected on the mornings of each of the three grazing days). However this could only be a problem on cold, dull days as on hot days the age of the bolus material was obvious.

(2) Extrusa analysis The freeze dried oesophageal extrusa samples were analysed for in vitro digestibility and composition. 1-5 gms dry weight of freeze dried material was obtained by quartering of the sample, and dissected into leaf, stem, dead matter and weed species. Final analysis being on an oven dry matter basis similar to herbage dry matter.

Digestible organic matter determinations were done, on a subsample of each replicate per grazing day, which had been finely ground and oven dried. The process being similar to the pasture digestible organic matter determinations.

Analyses were performed only on day 1 and day 3 samples due to the large number of samples involved.

III STATISTICAL METHODS

Analysis of variance techniques were used for the testing of significance between the various interaction

factors of days, periods, treatments and, where relevant, strata.

Least significant differences (LSD) were calculated at the 5%, 1% and 0.1% levels. The conventional notation for these levels of significance were used $p < 0.05$ *, $p < 0.01$ **, and $p < 0.001$ ***.

Techniques of linear regression were used in the computation of in vivo organic matter digestibilities from the in vitro digestion process. For each batch of in vitro samples a regression equation was computed from the "standard samples" which had known in vivo values. The regression took the form $Y = A + BX$. (Snedecor and Cochran 1968), which is a straight line, where Y is the in vivo OMD value, X the in vitro OMD value, and A and B constants.

IV SCHEDULE OF EXPERIMENTAL EVENTS

- | | |
|----------|---|
| 8-3-77 | Oesophageally fistulated 8 ewe hoggets. |
| 9-3-77 | Oesophageally fistulated 8 ewe hoggets. |
| 11-3-77 | Administered antibiotics post operation.
Animals returned from Palmerston North where surgery took place to Ballantrae, Terrace 3, where they continuously grazed the experimental area. They were regularly observed (every 2-3 days) for problems (eg. blockages) and drenched with anthelmintic every 5 to 6 weeks. |
| 16-10-77 | Animals weighed and assigned to treatments. Normal (spacer) similar aged ewe hoggets added to groups. |

23-11-77 Stocking rates for treatments decided at
24 and 36 su/ha (ie. 4 and 6 sheep per
plot respectively). New rotations commenced.

24-11-77 All sheep shorn, and hooves trimmed.

19-12-77 { Pasture sampling Plots 1a (afternoon)
20-12-77 { OF sampling (morning)
21-12-77 { OF sampling (morning) Pasture sampling
(afternoon)
22-12-77 { OF sampling (morning)
23-12-77 { Pasture sampling (morning)

16-20-1-78 Sampling on basis of above. Plots 1b.

13-17-2-78 Sampling Plots 2b.

6-3-78 Ryegrass staggers evident in two sheep

7-3-78 Sheep removed from plots. Pasture quality
insufficient to maintain animals.

8-3-78 Plot fences temporary removed.

9-3-78 Plots forage harvested of rank dead material.
Material was removed and burnt.

28-3-78 Experiment re-commenced with sheep rotating
on fresh autumn regrowth.

10-14-4-78 Sampled plots 3a.

1-5-5-78 Sampled plots 2a.

22-26-5-78 Sampled plots 1a.

27-5-78 Trial concluded.

CHAPTER 3.RESULTS1. Pasture Availability and 'utilization'

Total pasture and component dry matter availabilities before and after grazing are presented in Appendices 1, 3 and 5, and graphically illustrated for the Summer season (Figure 2) and the Autumn season (Figure 3). Analysis of variance are presented in Appendices 2, 4 and 6.

As expected the total pasture available decreased from day 1 to day 3, representing the grazing period. The only exception to this was at the third grazing period for the L treatment. The low-stocked (L) pasture had greater dry matter availabilities than the high-stocked (H) pasture, both before and after grazing. Both of these effects, viz. the reduction in pasture availability due to grazing and the greater quantity of pasture on the low-stocked treatments, were largely a reflection of the changes in the 'green matter' component of the pasture. By comparison the 'dead matter' component did not change significantly during grazing, suggesting that such material was avoided by the grazing animals. However, during the experimental periods there was a significant change in the dead matter component, reaching a peak at the third grazing period in late summer and steadily declining throughout the autumn. This build-up and decline was significantly more pronounced in the L treatment than the H treatment.

The available pasture during the Summer measurement periods was analysed further into strata, viz. the lower

FIGURE 2 PASTURE AVAILABILITY - SUMMER

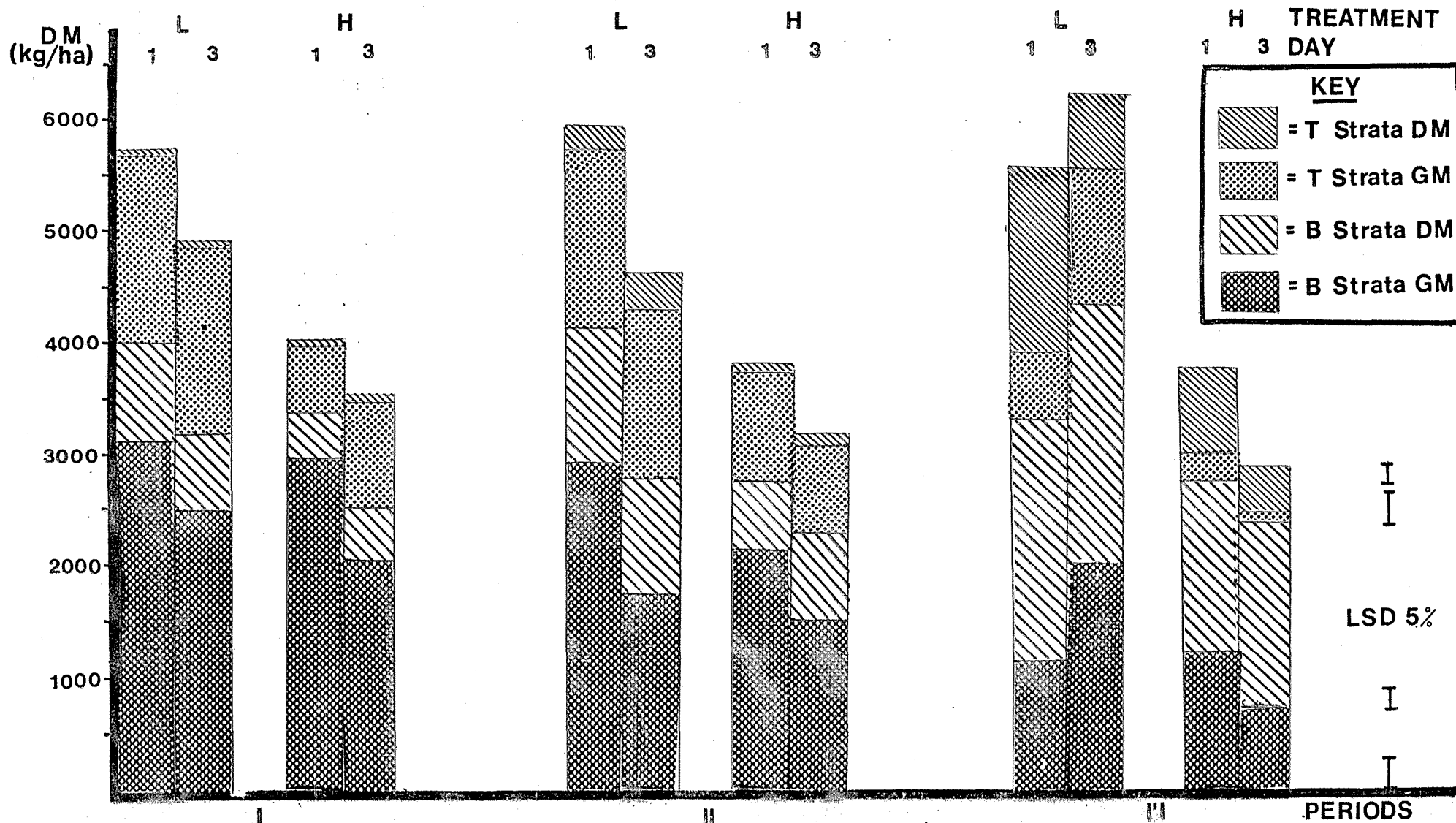
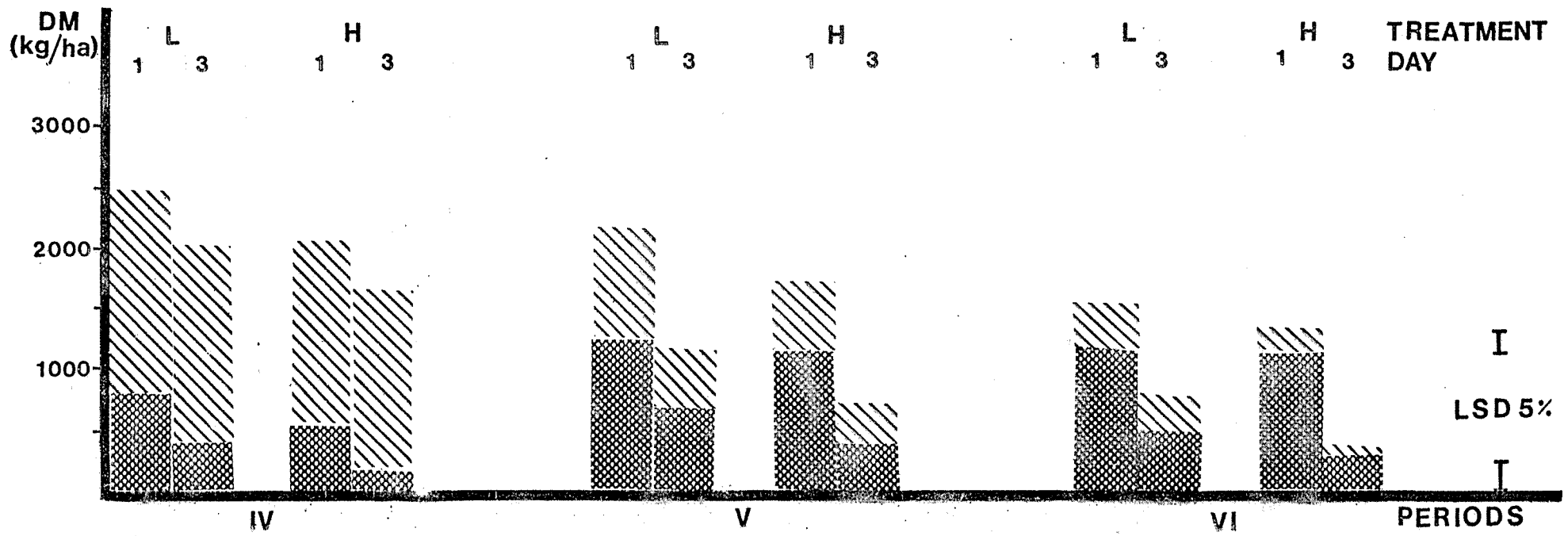
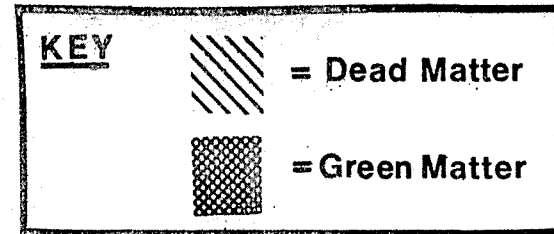

FIGURE 3 PASTURE AVAILABILITY - AUTUMN



100 mm (B) and above 100 mm (T) of the pasture profile, presented in Appendices 7 and 8, and graphically represented in Figure 2. This figure highlights the consistent greater dry matter availability of the B strata than the T strata and the significant stocking rate effect, similar to that effect as previously discussed for total pasture availability.

Pasture strata availabilities were also analysed into 'green matter' (Appendices 9 and 10) and 'dead matter' (Appendices 11 and 12), with presentation of this classification of dry matter also in Figure 2. As can be seen, the amount of green material available over the Summer, decreased as the amount of dead material increases, for both strata in the two stocking rate treatments. The L treatment had significantly more available 'green matter' and 'dead matter', in both strata, than the H treatment. The significant 'green matter' Strata x Days interaction recorded reflects a decreasing amount of green material in the B strata over the three-day grazing periods.

The difference between the pasture available immediately before grazing and the residue after grazing gives a measure of 'utilization' or 'intake' by the grazing animals. The estimated mean intake per sheep per day over the experimental duration was not significantly different between the low and the high stocked treatments (1.07 kg DM/sheep/day (L) v 0.85 kg DM/sheep/day (H)).

Table 1 presents the percentage utilization (ie. the proportion of the available herbage 'consumed' during

the three-day grazing periods) of the two stocking rate treatments for the Summer and Autumn seasons.

Table 1. Percentage Utilization of total available DM

Treatment	Season	
	Summer	Autumn
L	10.9%	37.3%
H	16.2%	46.7%

Statistical analyses (Appendix 13) confirm the significance ($p < 0.05$) of the greater percentage utilization in the Autumn compared to the Summer, and the non-significance of the differences between stocking rates. Analysis of pasture strata utilization (Appendix 14) confirm differences in levels to be not significant although the figures (Table 2) suggested that greater utilization of the bottom strata occurred.

Table 2. Percentage Strata Utilization of total available DM

Treatment	Strata	
	T	B
L	2.7%	8.8%
H	6.6%	16.5%

2. Pasture Composition

Samples of the available pasture were dissected into pasture leaf (grasses and legumes), pasture stem (grass

stem and legume stolons), other species (weed species), and dead matter. This dissection data is presented on a seasonal basis in Figures 4 and 5. The percentage compositions and amounts per hectare together with the respective statistical analyses are presented in Appendices 15 to 24.

A. Leaf The amount and percentage composition of the green leaf component of the pastures varied significantly ($p < 0.001$) over the experimental period, decreasing over the Summer reproductive phase, and then increasing in the Autumn following rains. There was a highly significant ($p < 0.001$) decline between day 1 and day 3 in the amount and percentage composition of the leaf available; reflecting the preference of the grazing animals. This is illustrated in Table 3 by the significant Periods x Days interaction.

Table 3. Amount of Green Leaf (kg/ha)

Days	Periods					
	I	II	III	IV	V	VI
1	1436	1315	556	461	984	1046
3	899	669	424	153	371	307
'Utilization'	537	646	132	308	613	739

Period IV and particularly Period III had low levels of green leaf 'utilization' which were probably influenced by the low levels of availability of this component, and the high levels of available dead material. Stocking

KEY - PASTURE COMPOSITION

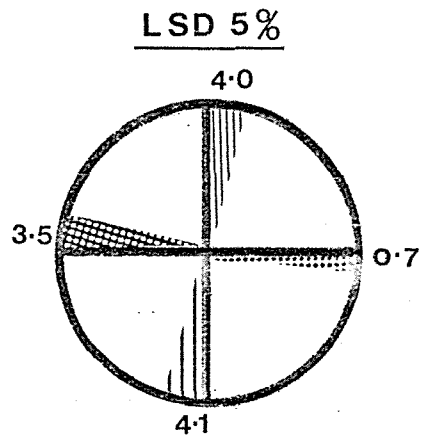
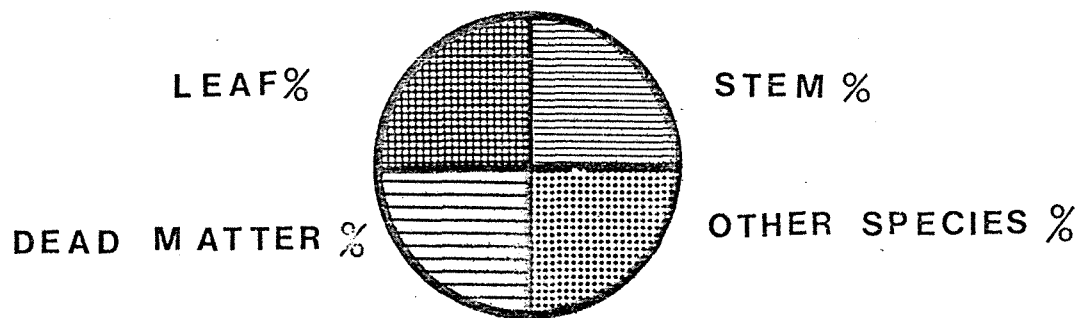

FIGURE 4 PASTURE COMPOSITION (%) - SUMMER

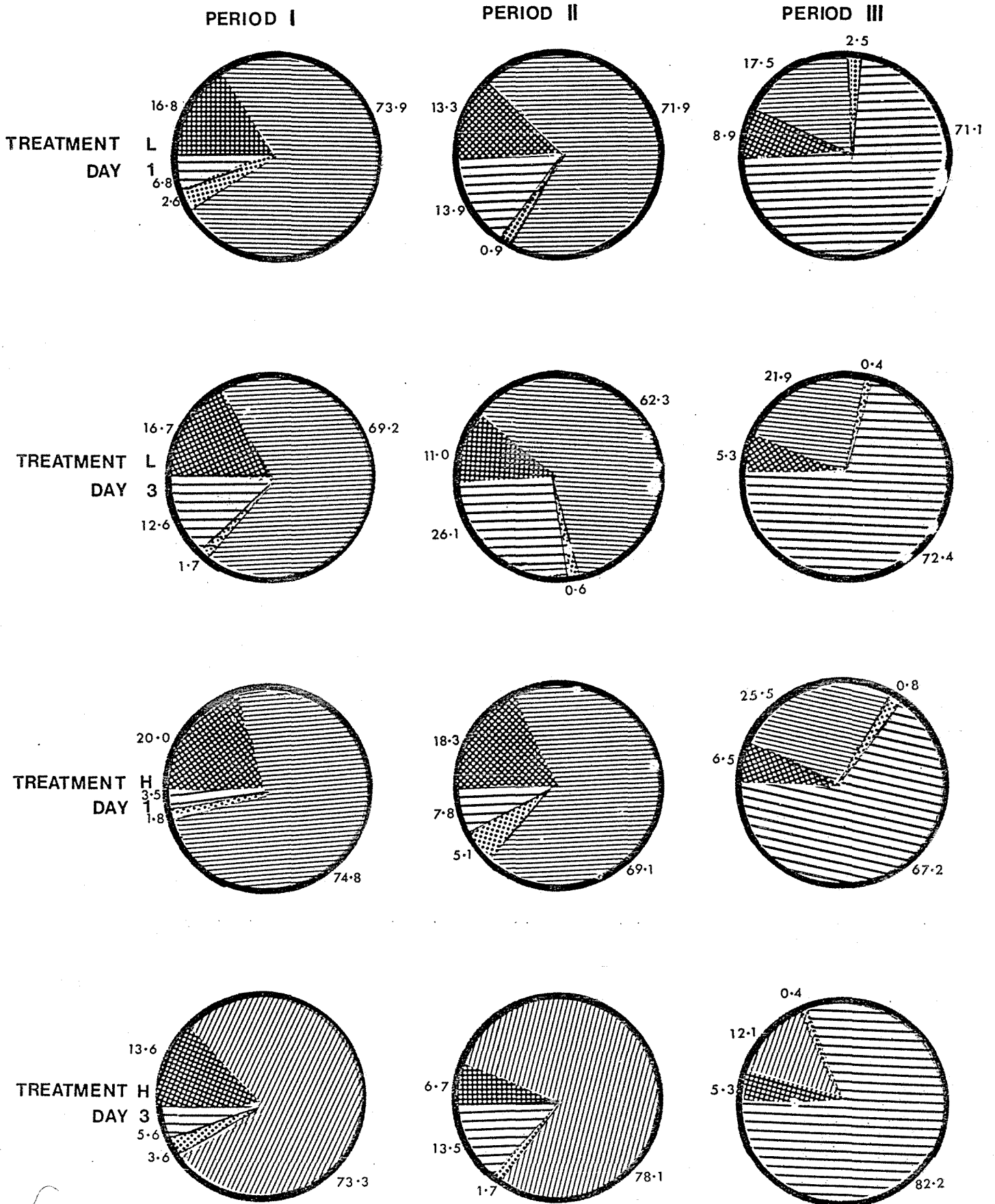
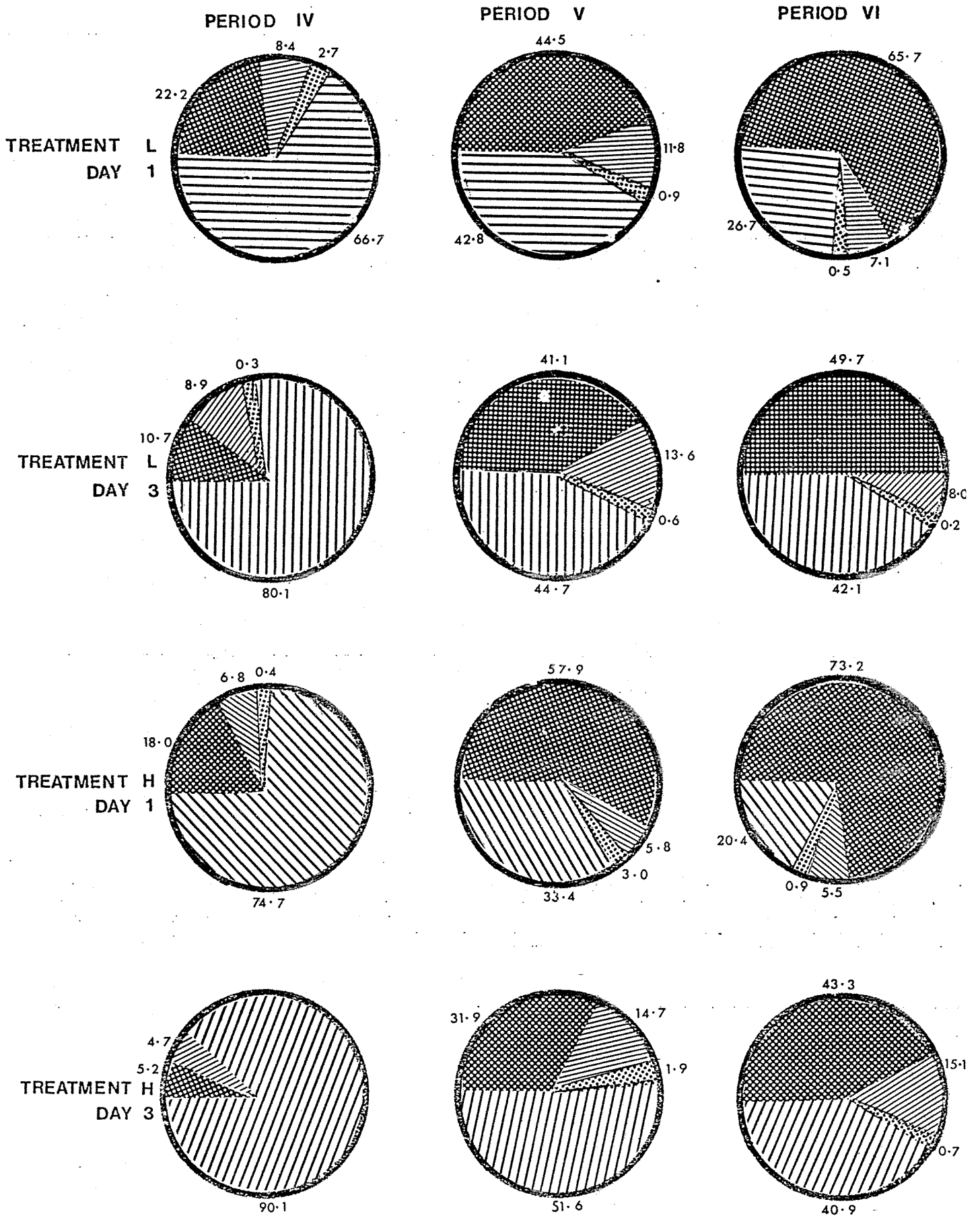

FIGURE 5 PASTURE COMPOSITION (%) - AUTUMN



rate had no significant influence on the amount or percentage of the green leaf available.

B. Stem The amount and percentage composition of the green pasture stem component varied significantly ($p < 0.001$) over the experimental duration, with a dramatic decrease in the late summer due to the increasing effect of the drought experienced (Refer Meteorological Data Figures 16 and 17), increasing the amount of dead stem and thus enhancing the dead matter component. The grazing sheep showed an avoidance of the green stem component in their diet, as indicated by the non-significant difference between day 1 and day 3 of this component of pasture availability. Although the percentage composition of the green stem in the available pasture was not significant between stocking rate treatments, the amount of green stem was highly significantly ($p < 0.001$) different between these two treatments; the L treatment having almost twice the amount of stem that the H treatment, except at the final Autumn grazing when green stem availability was low. Table 4 displays this stocking rate effect and its pattern over the six periods.

Table 4. Pasture Stem Availability (kg/ha)

Treatments	Periods					
	I	II	III	IV	V	VI
L	3221	2832	1409	194	209	89
H	1959	1638	657	113	109	75

C. Other Species (Weed Species) The availability of this pasture component decreased significantly ($p < 0.001$) over the experimental duration. A significant ($p < 0.05$) reduction in the availability of the weed species component from day 1 (86.3 kg/ha) to day 3 (46.4 kg/ha) indicated 'utilization' by the grazing animals, although this is not supported by the animal extrusa data.

D. Dead Matter The dead matter component of the pasture increased dramatically from 7.1% (628 kg/ha) to 73.2% (3001 kg/ha) over the summer, and then decreased in the autumn from 77.9% (1586 kg/ha) to 12.8% (312 kg/ha). Throughout these periods of varying compositions of dead matter the difference in availability between day 1 and day 3 remained non-significant, indicating dead matter to be a non-preferred component of the sheeps' diet. Stocking rate significantly ($p < 0.001$) affected the amount of dead matter present in the pasture, as indicated in Table 5; the lower stocked treatment (L) consistently having greater availabilities of dead matter than the higher stocked treatment (H).

Table 5. Amount of dead matter (kg/ha)

Treatments	Periods					
	I	II	III	IV	V	VI
L	890	1381	3787	1647	725	387
H	496	755	2217	1526	483	238

3. Pasture Strata Composition

The pasture strata composition data for the summer season are presented in Figure 6 (B strata) and Figure 7

KEY - PASTURE STRATA COMPOSITION

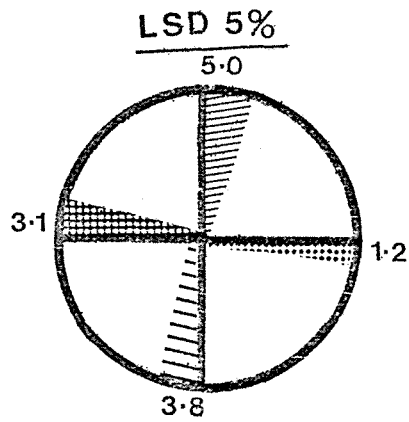
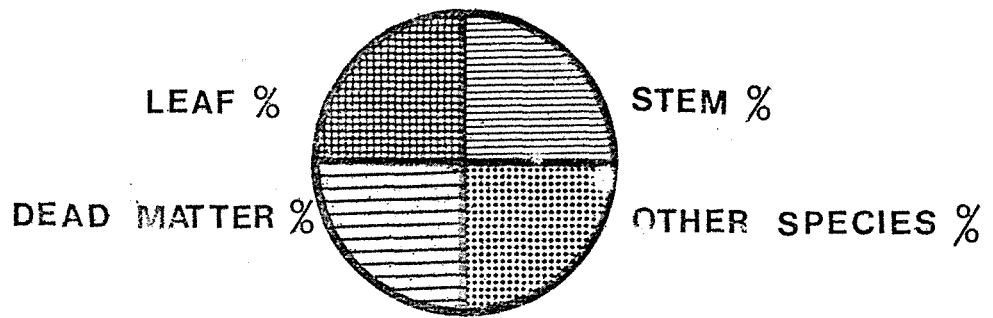

FIGURE 6 'B' STRATA PASTURE COMPOSITION - SUMMER (%)

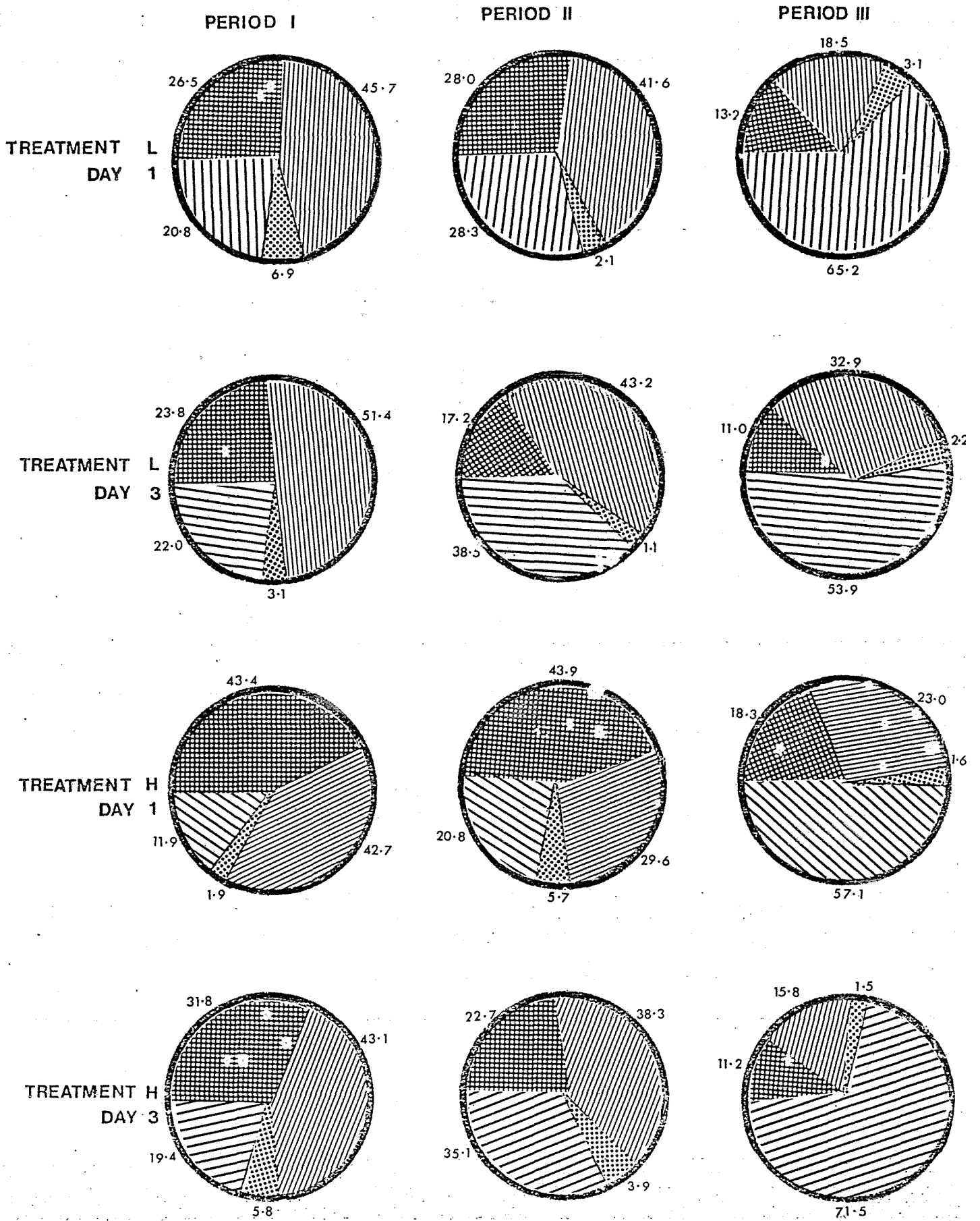
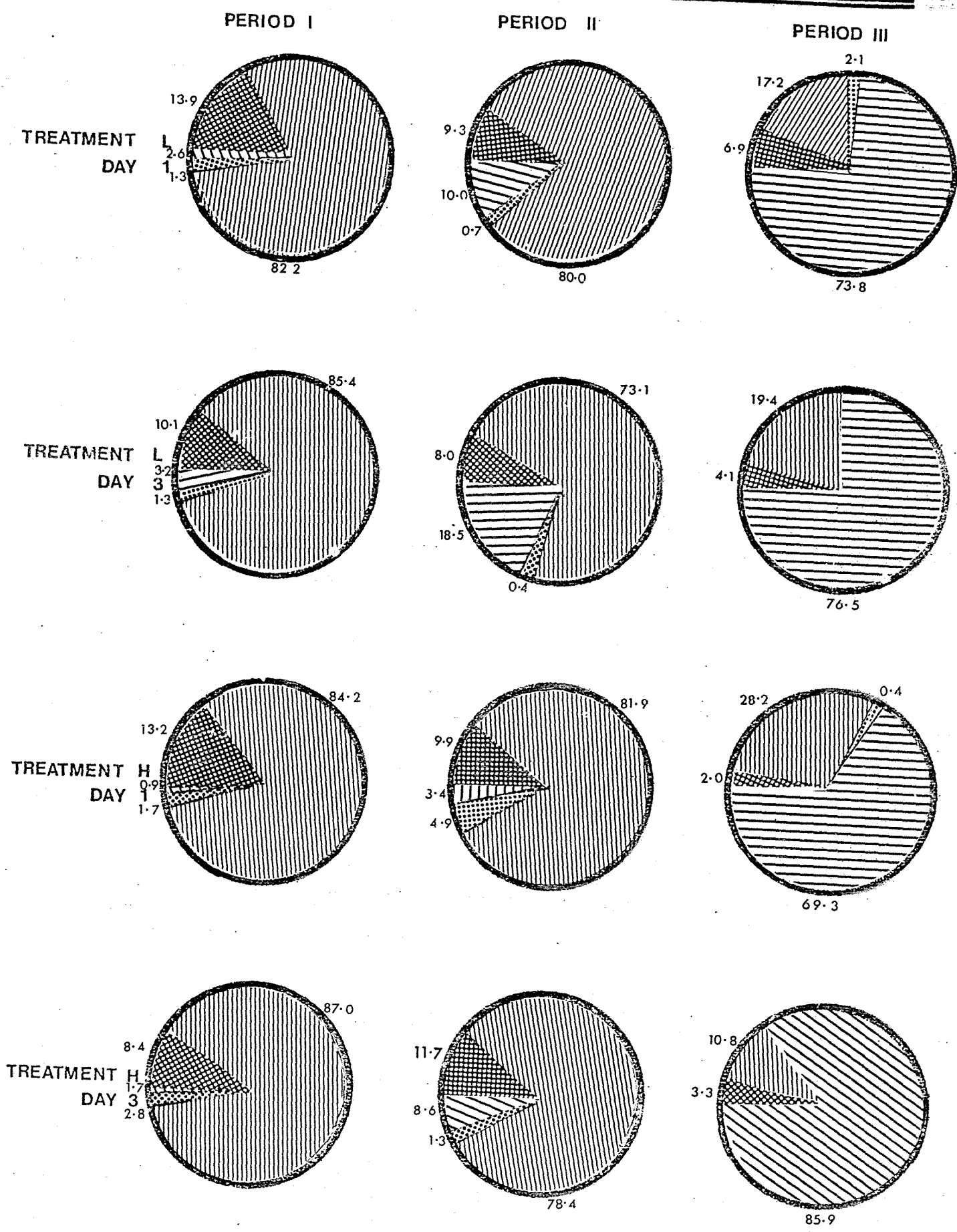

FIGURE 7 'T' STRATA PASTURE COMPOSITION - SUMMER (%)



(T strata). Percentage compositions, amounts per hectare and statistical analyses are presented in Appendices 25 to 34.

A. Leaf The B strata leaf composition was significantly ($p < 0.001$) greater than the T strata leaf composition in percentage (24% v 9%) and amount (760 kg/ha v 123 kg/ha). The highly significant ($p < 0.001$) interactions of Periods and Strata, are presented in Table 6, and illustrate the decreasing amount of leaf available progressing through the summer season, and the contrast between strata.

Table 6. Amount of Leaf (kg/ha)

Strata	Periods		
	I	II	III
T	153	149	68
B	1015	843	422

The highly significant ($p < 0.001$) decline in available green leaf from day 1 to day 3 is complemented by the highly significant ($p < 0.001$) Strata x Days interaction, presented in Table 7.

Table 7. Amount of leaf per Strata (kg/ha)

Strata	Days	
	1	3
T	133	113
B	969	551

These results indicate not only the apportionment of the green leaf component within the canopy, but also that the bulk of the leaf material 'utilized' by the grazing sheep was from the B strata.

B. Stem The B strata stem component was significantly ($p < 0.001$) greater than that of the T strata in amount (1149 kg/ha v 804 kg/ha), but the T strata had a significantly greater percentage composition of green stem than the B strata (61% v 35%). The highly significant Periods x Strata interaction, illustrated in Table 8, shows dramatic transformations in the percentage of green stem in the strata, with a marked decline in the T strata in the late summer, as the drought affected material was classified as dead matter.

Table 8. Percentage Stem of Pasture Composition

Strata	Periods		
	I	II	III
T	84.7	80.5	18.9
B	45.2	38.2	22.5

C. Other Species Flatweeds constituted a major portion of the weed species category, and because of their prostrate growth habit, the B strata had a significantly ($p < 0.001$) greater weed species component than the T strata. Weeds contributed little to pasture availability; 1.4% for the T strata, and 3.2% for the B strata.

D. Dead Matter The B strata contained significantly more dead matter (1147 kg/ha = 37%) than the T strata (419 kg/ha = 30%) over the summer experimental duration. The highly significant ($p < 0.001$) dramatic increase in the percentage dead matter composition over the summer for the two strata is presented in Table 9.

Table 9. Strata Dead Matter Composition (%)

Strata	Periods		
	I	II	III
T	2.1	10.1	76.4
B	18.5	30.7	61.9

This complements the results of Table 8 for period III, illustrating the substantial increase in dead matter, in the T strata, at the expense of green stem.

4. Animal Extrusa Composition

Animal extrusa material was subsampled and dissected into: pasture leaf (grasses and legumes), pasture stem (grass stem and legume stolons), other species (weed species), and dead matter - an identical classification to the pasture composition dissection. Percentage diet composition dissection results are illustrated in Figure 8 (Summer) and Figure 9 (Autumn), tabulated and statistically analysed in Appendices 35 to 39.

A. Leaf Green leaf was a highly preferred diet component, and comprised a mean 89% of the diet measured

KEY - ANIMAL EXTRUSA COMPOSITION

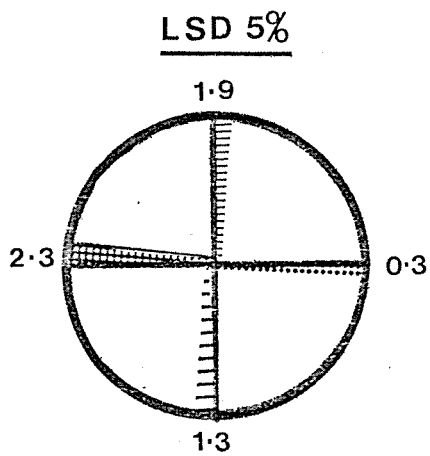
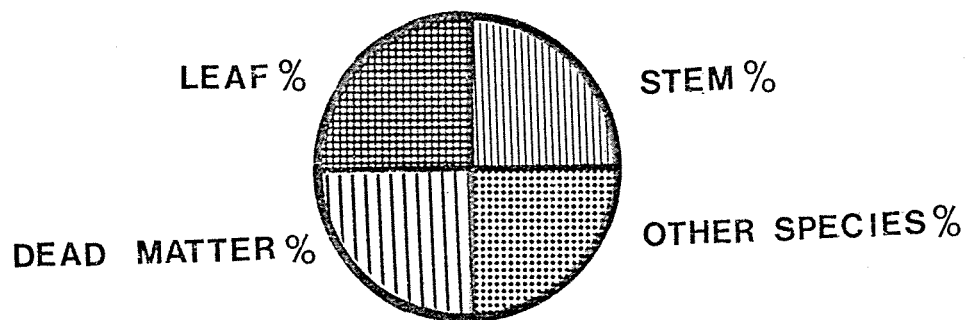

FIGURE 8 ANIMAL EXTRUSA COMPOSITION(%) - SUMMER

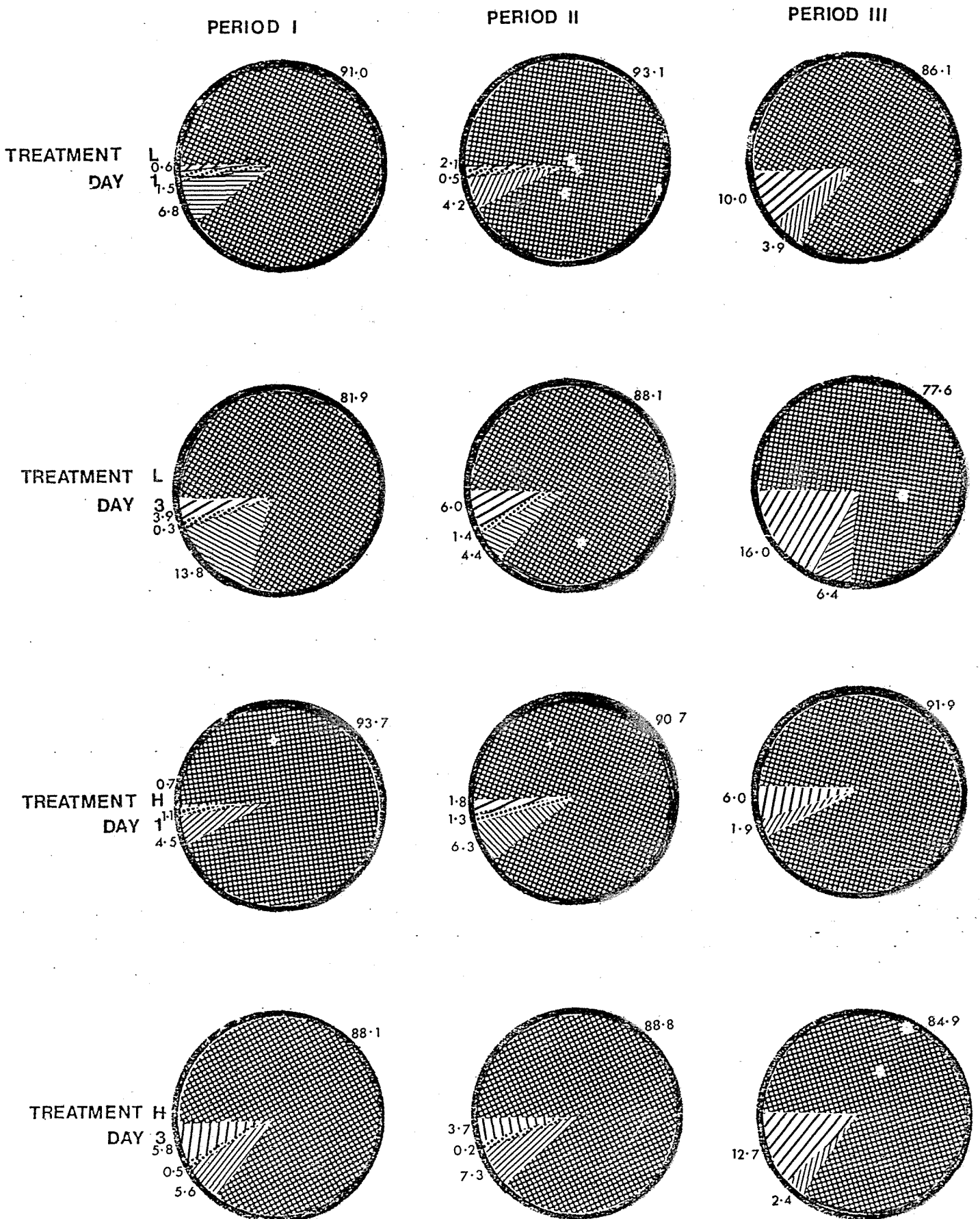
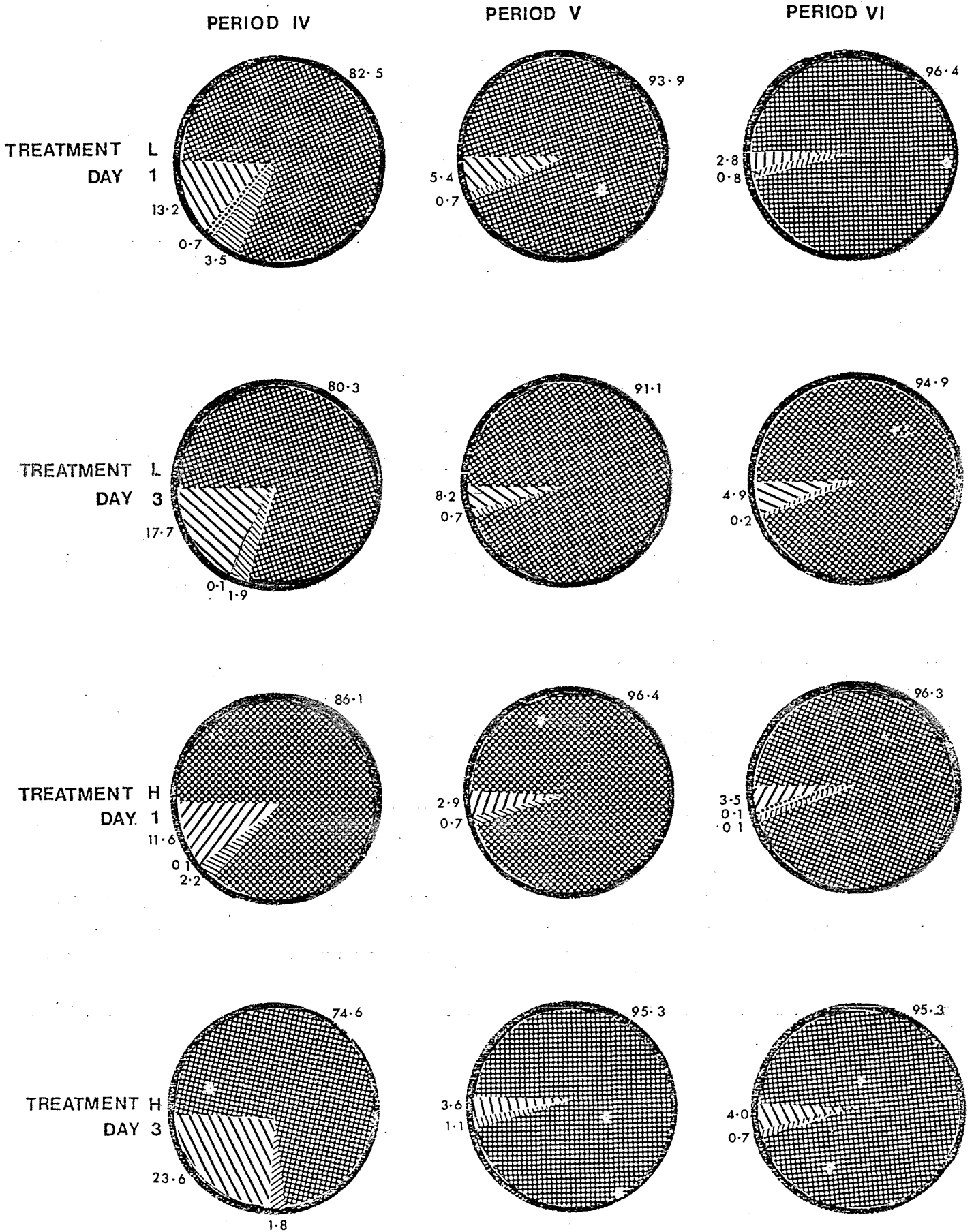

FIGURE 9 ANIMAL EXTRUSA COMPOSITION (%) - AUTUMN



over the experimental period. The increase in the percentage diet composition of green leaf over the Autumn from 81% to 96% illustrates this animal preference, and the animals ability to select as the availability and accessibility of the leaf component increases in the pasture. The significantly higher leaf composition on day 1 compared to day 3 reinforces the previous interpretation of diet selection by the grazing sheep. The lower leaf content in the L treatment extrusa samples compared with the H treatment was not significant.

B. Stem The green stem composition of the diet decreased significantly ($p < 0.001$) over the experiment from 8% to 0.4%. This compares with green stem availabilities in the pasture of 74% to 9%, and emphasises the avoidance of green stem in the animals' diet selection in this experiment. The small differences in dietary stem composition between stocking rate treatments, and over the three-day grazing periods were not significant.

C. Other Species There was a significant ($p < 0.01$) decrease in the percentage contribution of weed species in the diet over the experiment from 0.9% to 0.02%, corresponding to availabilities in the pasture of 2.4% and 0.6% respectively. The decreasing weed composition of the diet from day 1 to day 3 was not significant. Stocking rate did not significantly influence the weed species contribution to the diet composition.

D. Dead Matter Dietary dead matter composition exhibited a significant ($p < 0.001$) period response increasing over the summer as dead matter pasture availability increased, and declining over the autumn as the dead matter available diminished through decomposition. The dietary intake of dead matter increased over the three-day grazing periods (Day 1 = 5%; Day 3 = 9.2%), presumably caused more by accident than choice, due possibly to interactions of sward structure and availability. These significant dietary dead matter responses resulted in a cumulative significant ($p < 0.05$) Periods x Days interaction; illustrated in Table 10.

Table 10. Extrusa Dead Matter Composition (%)

Days	Periods					
	I	II	III	IV	V	VI
1	0.6	1.9	8.0	12.4	4.1	3.1
3	4.8	4.8	14.3	20.6	5.9	4.5

The L stocking rate treatment had slightly more dead matter dietary intake than the H treatment, (viz. 7.6% v 6.7%), but this difference was not significant.

5. Pasture Composition: Animal Diet Composition

The results of a statistical comparison between the available pasture composition and the animal diet composition, is presented in Appendix 40. The differences in composition between the pasture and the diet are highly

significant ($p < 0.001$) and conclusively show dietary preferences.

These differences can be clearly seen in comparing Figures 4 and 5 with Figures 8 and 9 respectively; and in Table 11.

Table 11. Composition Comparison: Pasture v Diet for leaf (L), stem (S), other species (OS) and dead matter (D). (%)

	L	S	OS	D
Pasture Composition	25.23	31.82	1.41	41.52
Diet Composition	89.15	3.42	0.33	7.10

Green leaf was the preferred dietary component of the pasture, with the dead matter component essentially rejected, and stem and weed species consumed in small amounts.

The highly significant ($p < 0.001$) interaction of Composition x Periods comparison between animal and pasture is presented in Table 12, illustrating the patterns of the dietary component intake, over the experiment compared with changes in pasture component availability.

Table 12. Pasture (P) v Animal (A) Composition x
Periods Interaction.

	Periods	Composition (%)			
		L	S	OS	D
Pasture	I	16.76	73.75	2.40	7.10
	II	12.30	70.33	2.07	15.31
	III	6.50	19.25	0.99	73.22
	IV	14.02	7.20	0.82	77.91
	V	43.82	11.47	1.55	43.12
	VI	57.97 ***	8.88 ***	0.58 *	32.53 ***
Animal	I	88.68	7.67	0.86	2.74
	II	90.19	5.55	0.85	3.37
	III	85.13	3.65	0.04	11.14
	IV	80.84	2.38	0.22	16.52
	V	94.30	0.81	0.37	5.01
	VI	95.72 ***	0.43 ***	0.01 **	3.81 ***

The composition of the diet followed a pattern similar to the variation in pasture composition, over the experimental period.

Similarly a pattern emerged from the highly significant ($p < 0.001$) interaction of Composition x Days comparison between animal and pasture, as illustrated in Table 13.

Table 13. Pasture v Animal Composition x Days
Interaction

	Days	Composition			
		L	S	OS	D
Pasture	1	30.43	31.49	1.82	36.24
	3	20.02 ***	32.14 NS	0.99 *	46.83 ***
Animal	1	91.51	2.96	0.45	5.04
	3	86.78 ***	3.86 NS	0.20 NS	9.16 ***

The preferred leaf component decreased in dietary composition as its percentage availability in the pasture decreased, while the non-preferred dead matter component increased in dietary composition as its percentage availability in the pasture increased, over the three-day grazing periods. The changes in the diet composition between day 1 and day 3 for stem, and weed species were not significant, but were significantly ($p < 0.001$) less than the percentages available in the pasture.

6. Pasture Digestibility

Organic matter digestibility (OMD %) of the pasture decreased significantly over the summer period from 61% to 55% (Figure 10) and increased significantly over the autumn period from 57% to 71% (Figure 11). The digestibility results (Appendix 41) and their statistical analyses (Appendix 42) show a highly significant ($p < 0.001$) decline in the mean pasture digestibilities over the three-day grazing periods, although period II shows an increase in digestibility from day 1 to day 3. These results are

FIGURE 10

PASTURE DIGESTIBILITY - SUMMER

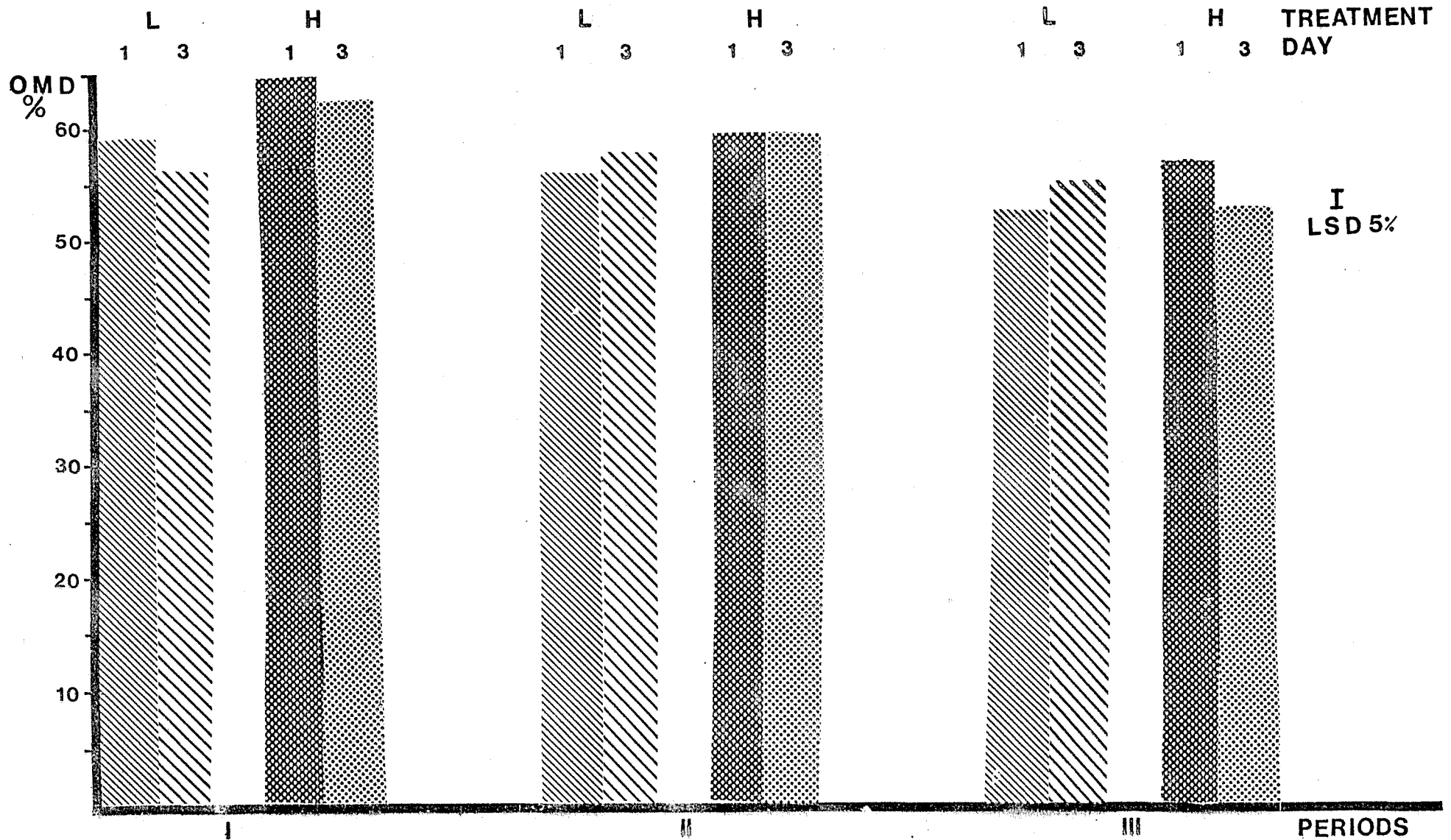
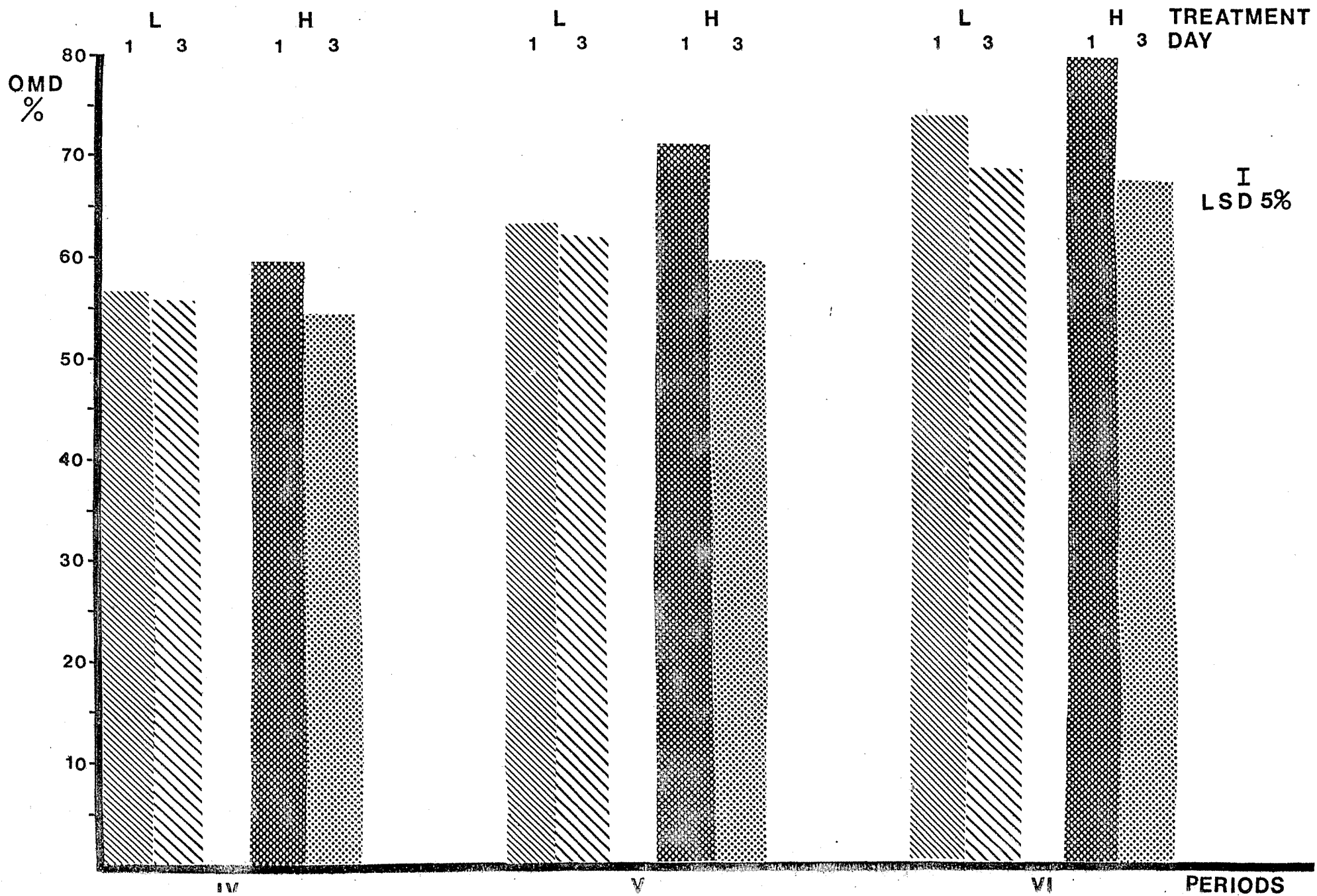

FIGURE II PASTURE DIGESTIBILITY - AUTUMN



illustrated in Table 14, which also exemplifies the considerable variation in the digestibility of the pasture before and after grazing according to season.

Table 14. Pasture Digestibility (OMD %) (Periods x Days)

Days	Periods					
	I	II	III	IV	V	VI
1	61.88	57.98	54.99	58.14	67.11	76.49
2	59.58	58.90	54.35	55.29	60.81	67.77

In the summer there was little change in the digestibility of the pasture before and after grazing, while in the autumn digestibility was considerably higher and the decline significant - again suggesting selective grazing at this time.

Stocking rate also influenced pasture digestibility, the H treatment having significantly higher organic matter digestibility, but only apparent before grazing - as shown in the significant Days x Treatments interaction (Table 15).

Table 15. Pasture Digestibility (OMD %) (Treatments x Days)

Days	Treatments	
	L	H
1	60.30	65.22
3	59.40	59.50

7. Pasture Strata Digestibility

Organic matter digestibilities of the pasture strata are illustrated in Figure 12, with further data presented in Appendix 43, and analysed in Appendix 44. Highlighted in these results is the substantially higher ($p < 0.001$) OMD % value of the B strata than the T strata.

8. Animal Extrusa Digestibility

The digestibility values of the sheeps' diet are illustrated for seasons in Figure 13 (summer) and Figure 14 (autumn), with the data presented in Appendix 45 and analysed in Appendix 46.

The digestibility of the diet was significantly ($p < 0.001$) higher on day 1 than day 3, highlighting the animals' ability to be more selective in diet composition on the first day than at the end of the grazing period. The extrusa digestibilities differ significantly ($p < 0.001$) between periods; increasing from Period 1 to Period II, then decreasing in Period III as the dead matter content of the diet increased, and then increasing again over the Autumn as the dead matter content decreased and green leaf increased. Stocking rate had no significant effect on diet digestibility although the H values were slightly higher than those of the L treatment.

9. Pasture Digestibility: Animal Digestibility

The comparison of the digestibility of the sheeps' diet and the available pasture, illustrated in Figure 15, highlights these two classes (viz. animal diet and available

FIGURE 12

PASTURE STRATA DIGESTIBILITY

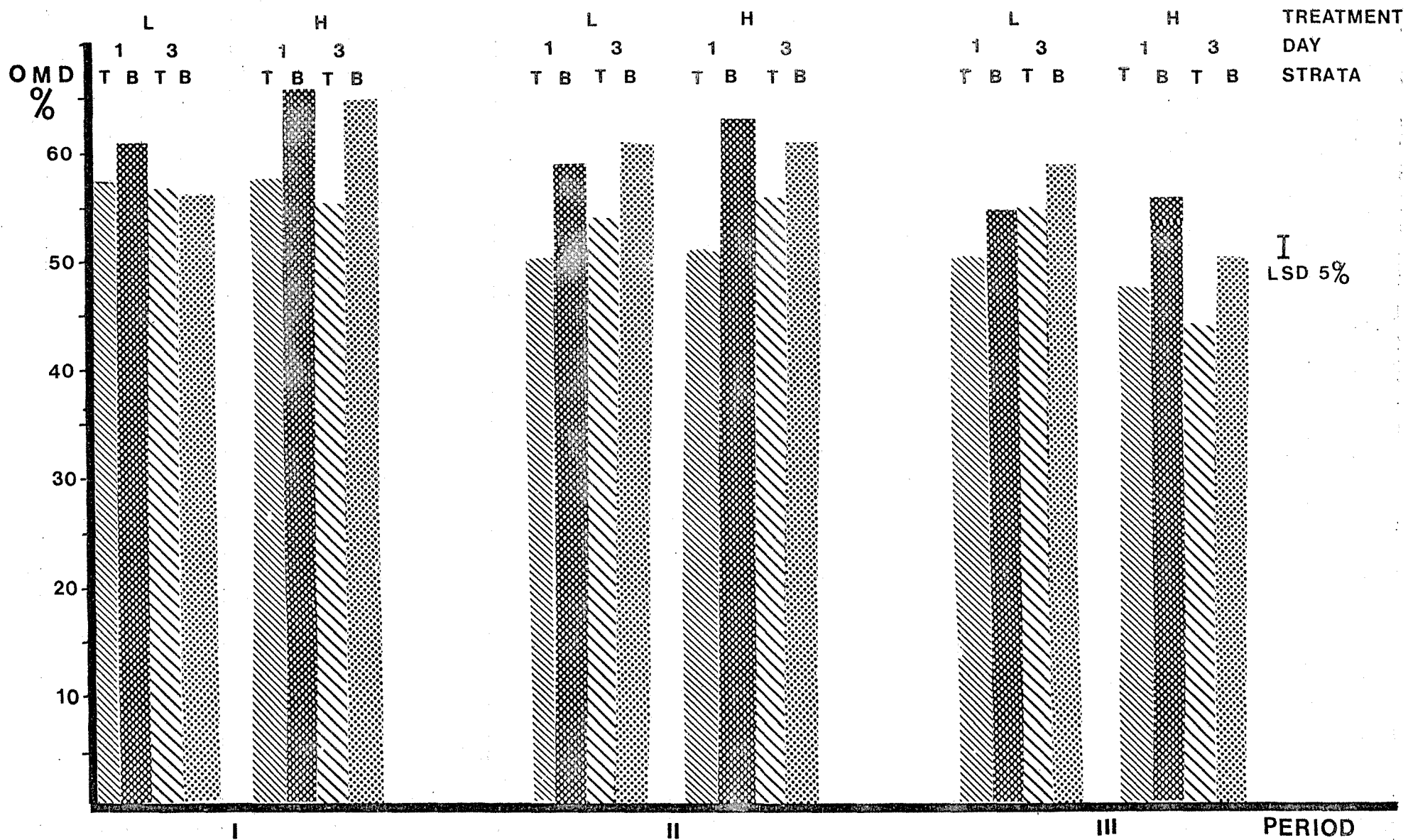
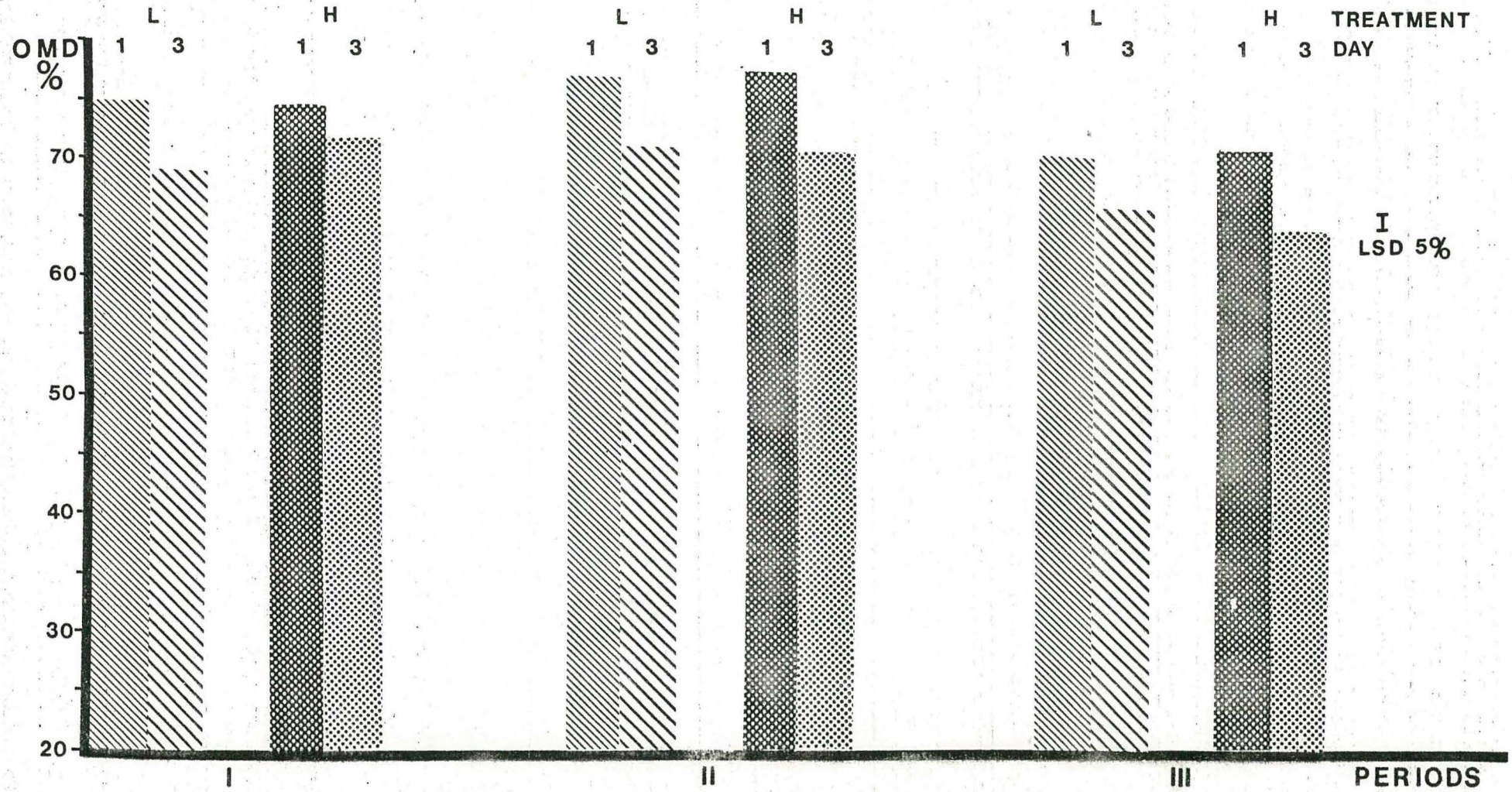

FIGURE 13 **ANIMAL EXTRUSA DIGESTIBILITY** - **SUMMER**

v



MASSEY UNIVERSITY
LIBRARY

FIGURE 14 **ANIMAL EXTRUSA DIGESTIBILITY** - **AUTUMN**

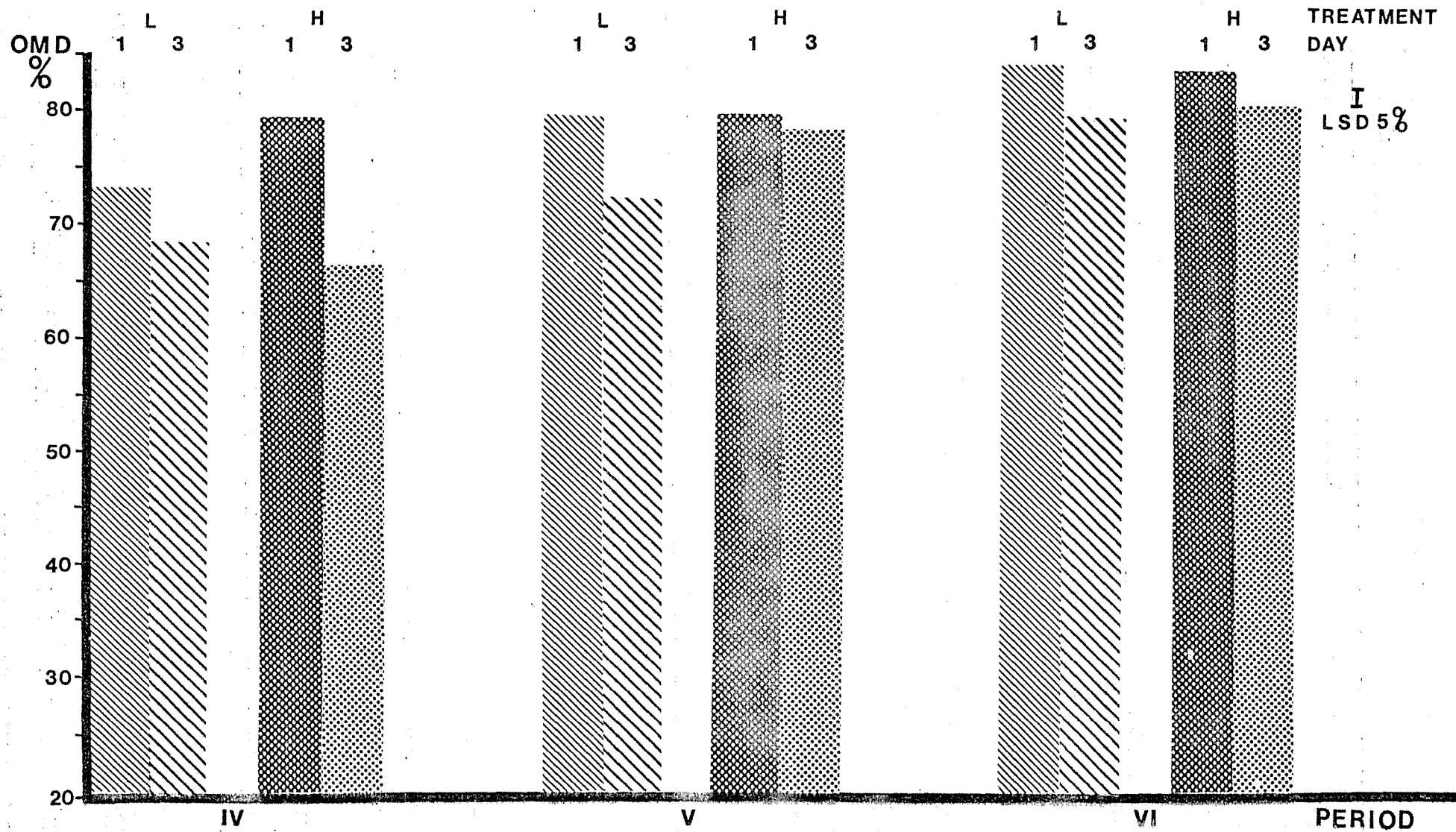
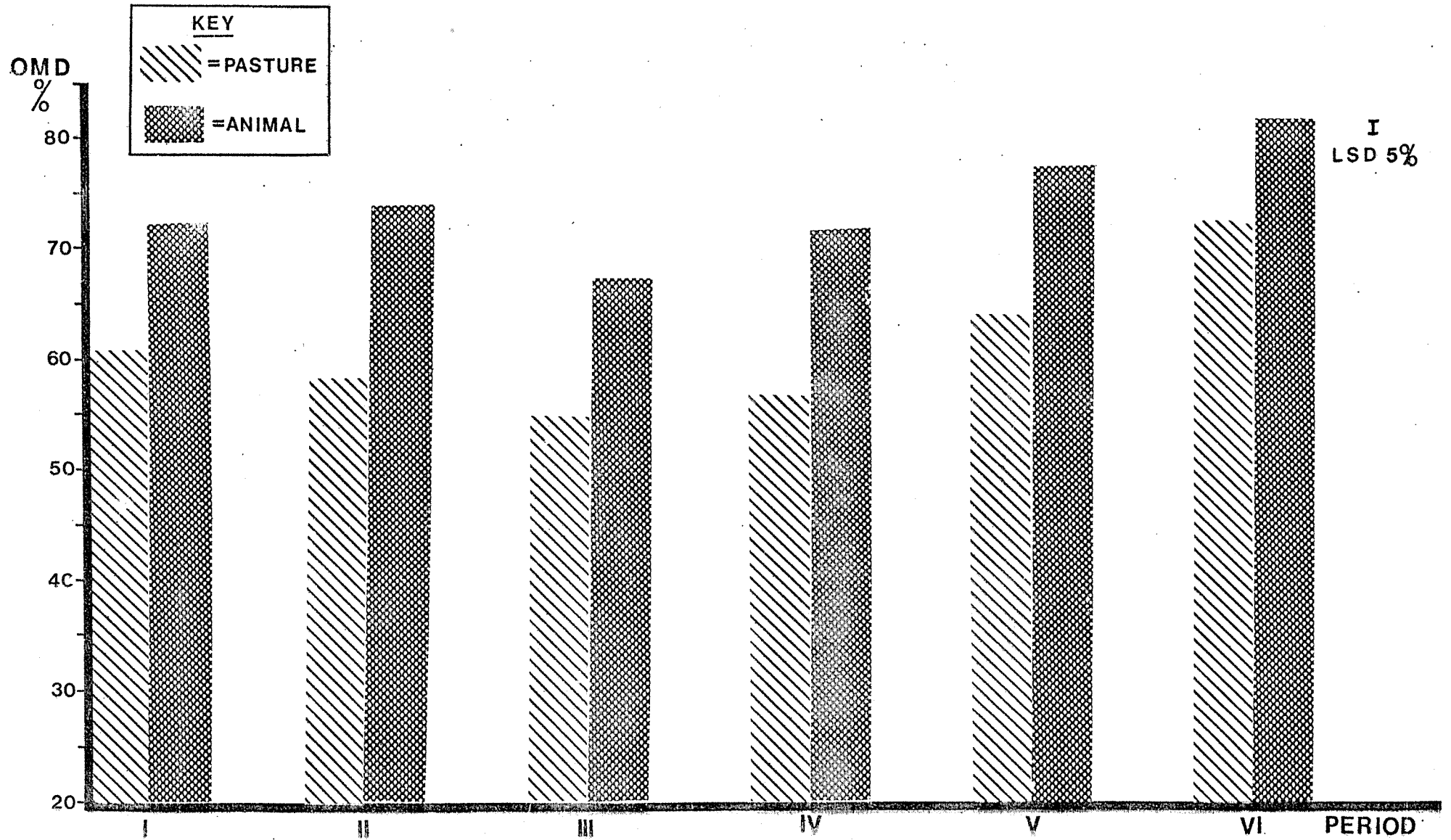

FIGURE 15

PASTURE DIGESTIBILITY : ANIMAL EXTRUSA DIGESTIBILITY



pasture). The consistently higher digestibility values of the diet conclusively show the animals' ability, in this trial, to be selective in diet composition. The digestibility decrease over the three-day grazing period of the pasture (3.3%) compared to the animal extrusa (5.5%) was not significant. However there was a significant ($p < 0.05$) interaction between the pasture and animal diet digestibilities for the six grazing periods as shown in Table 16.

Table 16. Pasture:Animal Diet Digestibility Comparison

	Periods					
	I	II	III	IV	V	VI
Pasture OMD%	60.73	58.44	54.67	56.67	63.96	72.13
Animal OMD%	72.48	73.92	67.54	71.88	77.46	81.65
Difference (Animal-Pasture)	11.75	15.48	12.87	15.21	13.50	9.52

10. Pasture Species

Pasture dissection data and analysis for the major contributing species (viz. Lolium perenne, Agrostis tenuis, Cynosurus cristatus, Anthoxanthum odoratum, Poa spp, Holcus lanatus and Trifolium spp.) as components of the total and strata pasture availabilities, are recorded in Appendices 48 - 77.

Table 17 summarises the percentage contribution of these species to the pasture for the summer and autumn seasons, as well as including the contribution of dead matter.

Table 17. Species Contribution to available pasture (%)

Species	Season	
	Summer	Autumn
Perennial ryegrass (<u>Lolium perenne</u>)	22.4	31.5
Browntop (<u>Agrostis tenuis</u>)	13.2	9.8
Crested dogstail (<u>Cynosurus cristatus</u>)	11.7	0.7
Sweet vernal (<u>Anthoxanthum odoratum</u>)	5.6	1.4
<u>Poa</u> species	5.2	2.5
Yorkshire fog (<u>Holcus lanatus</u>)	6.5	1.2
<u>Trifolium</u> species	2.4	0.5
Dead matter	31.9	51.2

A. Lolium perenne - A dietary preference for this major contributing species was indicated by the significantly ($p < 0.001$) greater amount and percentage, of Lolium perenne on day 1 than on day 3. Stocking rate influenced the availability of perennial ryegrass, particularly during the summer as shown in Table 18. The L stocking rate generally had a higher availability of this species, except for period IV.

Table 18. Availability of Lolium perenne (kg/ha)

Treatments	Periods					
	I	II	III	IV	V	VI
L	2025	1064	770	159	792	475
H	1163	688	328	232	624	438

Perennial ryegrass, as green matter, contributed 31% to the T strata, and 19% to the B strata availability. However the B strata contained a significantly ($p < 0.01$) greater amount of ryegrass than the T strata, but only at the higher stocking rate (Table 19).

Table 19. Strata availability of Lolium perenne (kg/ha)

Treatments	Strata	
	T	B
L	643.2	643.3
H	197.6	528.6

B. Agrostis tenuis - Browntop (Agrostis tenuis), the second greatest contributing species, appeared to be preferred by the sheep as indicated by the significant lower availability at the end of the three-day grazing period, compared with the beginning. This observation is supported by the decreasing amount of Agrostis tenuis available over the trial duration. The higher stocking rate treatment (H) contained significantly ($p < 0.05$) less Agrostis tenuis than the L treatment, although both

treatments had a mean pasture availability composition, of this species, of 11%. The B strata contained a greater amount and percentage of browntop than the T strata, even though the amount in the B strata decreased, and the amount in the T strata increased, during the summer as reproductive development proceeded, as shown in Table 20.

Table 20. Strata availability of Agrostis tenuis (kg/ha)

Strata	Periods		
	I	II	III
T	66.1	110.2	196.4
B	568.8	436.1	401.3

C. Cynosurus cristatus - The contribution of this species to total dry matter availability varied considerably from 11.7% (summer) to 0.7% (autumn), with a significantly ($p < 0.01$) greater portion in the T than the B strata during the summer experimental period. The non-significant difference between day 1 and day 3 for the amount of Cynosurus cristatus could be interpreted as a lack of preference shown for this species by the grazing animal.

D. Anthoxanthum odoratum - Sweet vernal contributed more in the summer (5.6%), than in the autumn (1.4%) to available green matter, with a significantly greater amount of this available in the B strata (200 kg/ha) than the T (42 kg/ha) during the three summer grazing periods. The lower availability of this species on day 3 compared to day 1 was not significant.

E. Poa Species - Poa annua with traces of Poa pratensis, together contributed a low, mean 3.9% of available green matter with a larger amount of this in the B strata (215 kg/ha) than in the T strata (39 kg/ha) over the summer experimental periods. The small decrease in availability for this species group, over the three-day grazing period was not significant.

F. Holcus lanatus - The summer contribution of Yorkshire fog to green matter availability was 6.5% with a greater ($p < 0.001$) amount in the B (221 kg/ha) than the T (72 kg/ha) strata, compared with 1.2% in the autumn. The significant ($p < 0.01$) decrease in amount of this species over the three-day grazing period was not consistent for all periods (Table 21) and therefore any inference of preference by the grazing animals for this species is inconclusive from this data.

Table 21. Availability of Holcus lanatus (kg/ha)

Days	Periods					
	I	II	III	IV	V	VI
1	184.7	624.9	226.2	7.6	57.3	18.1
3	206.2	229.1	237.9	15.7	15.0	4.4

G. Trifolium species - Trifolium repens with traces of Trifolium pratense, contributed 2.4% to summer pasture availability and 0.5% to autumn pasture availability. Although this species group was a minor contributor to pasture availability, it did appear to have dietary

preference to the grazing sheep as indicated by the significant ($p < 0.05$) decline in availability over the three-day grazing periods. This legume group, being predominantly prostrate species, contributed significantly more to the B than to the T strata (viz. 101 kg/ha v 8 kg/ha).

11. Weed species

The percentage contribution of this group to the available herbage, where applicable, is presented in Appendix 78. The following weed species were identified.

<u>Luzula</u> spp.	-	Woodrushes
<u>Leontodon taraxacoides</u> (LEle)	-	Hawkbit
<u>Hypochoeris radicata</u> (HYra)	-	Catsear
<u>Bellis perennis</u> (BEpe)	-	Daisy
<u>Taraxacum officinale</u> (TAof)	-	Dandelion
<u>Plantago lanceolata</u> (PLla)	-	Plantain
<u>Cerastium glomeratum</u> (CEgl)	-	Mouse - ear chickweed

The percentage contribution of these individual species, and collectively were minimal to the amount of available herbage.

12. Oesophageal fistula sheep liveweight

Following a small and temporary drop in liveweight after the fistula operation, the sheep steadily increased weight to a mean of 52.3 kg at the commencement of the experiment. As shown in Table 22 the liveweight of the

experimental animals changed little during the course of the experiment, with a non-significant decrease being recorded. Similarly there was no significant difference in the mean liveweight of the sheep on the L and H stocked treatments.

Table 22. Mean O.F. Sheep Liveweights (kg)

Treatment	10-10-77	26-5-78	Mean
L	51.3	48.8	50.0
H	53.0	51.7	52.3
Mean	52.3	50.5	

13. Climate

Rainfall data, illustrated in Figure 16, and presented in Appendix 80 and 81, compares the precipitation experienced during the trial with the mean value of the previous 9 years. Early summer rainfall was high, but rainfall during the late summer/early autumn period was extremely low, with this consequent drought having a disastrous influence on pasture growth and quality. High soil temperatures, illustrated in Figure 17, were a product of this drought. Windrun experienced during the experimental period was also above the normal, as shown in Figure 18. This also would have increased the dessicating influence of the drought. Conditions became more favourable for pasture growth in mid-autumn due to rains, low windrun and high soil temperatures.

FIGURE 16

MEAN MONTHLY RAINFALL

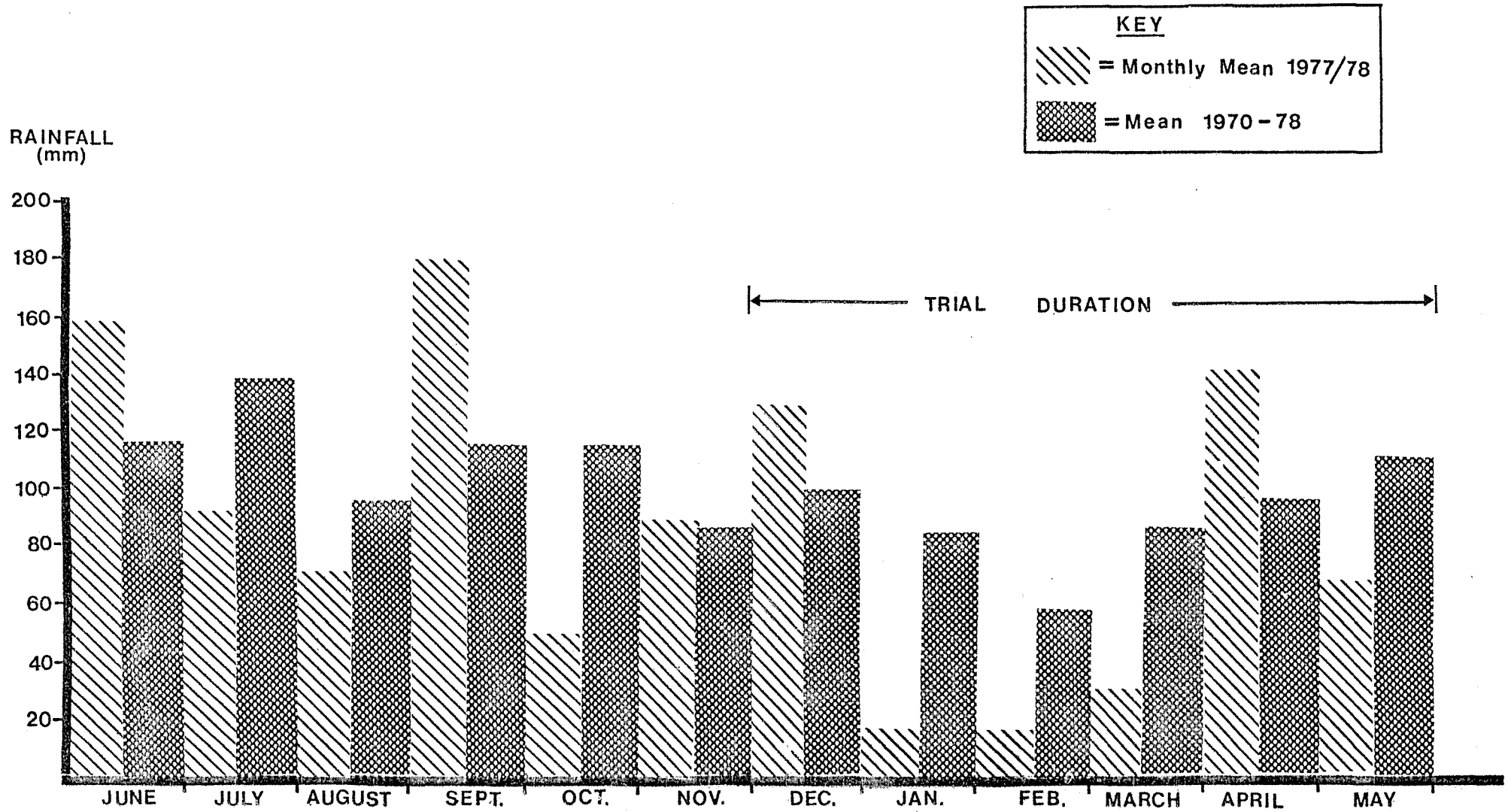

FIGURE 17

SOIL TEMPERATURE

SOIL TEMP.
(10 CM)

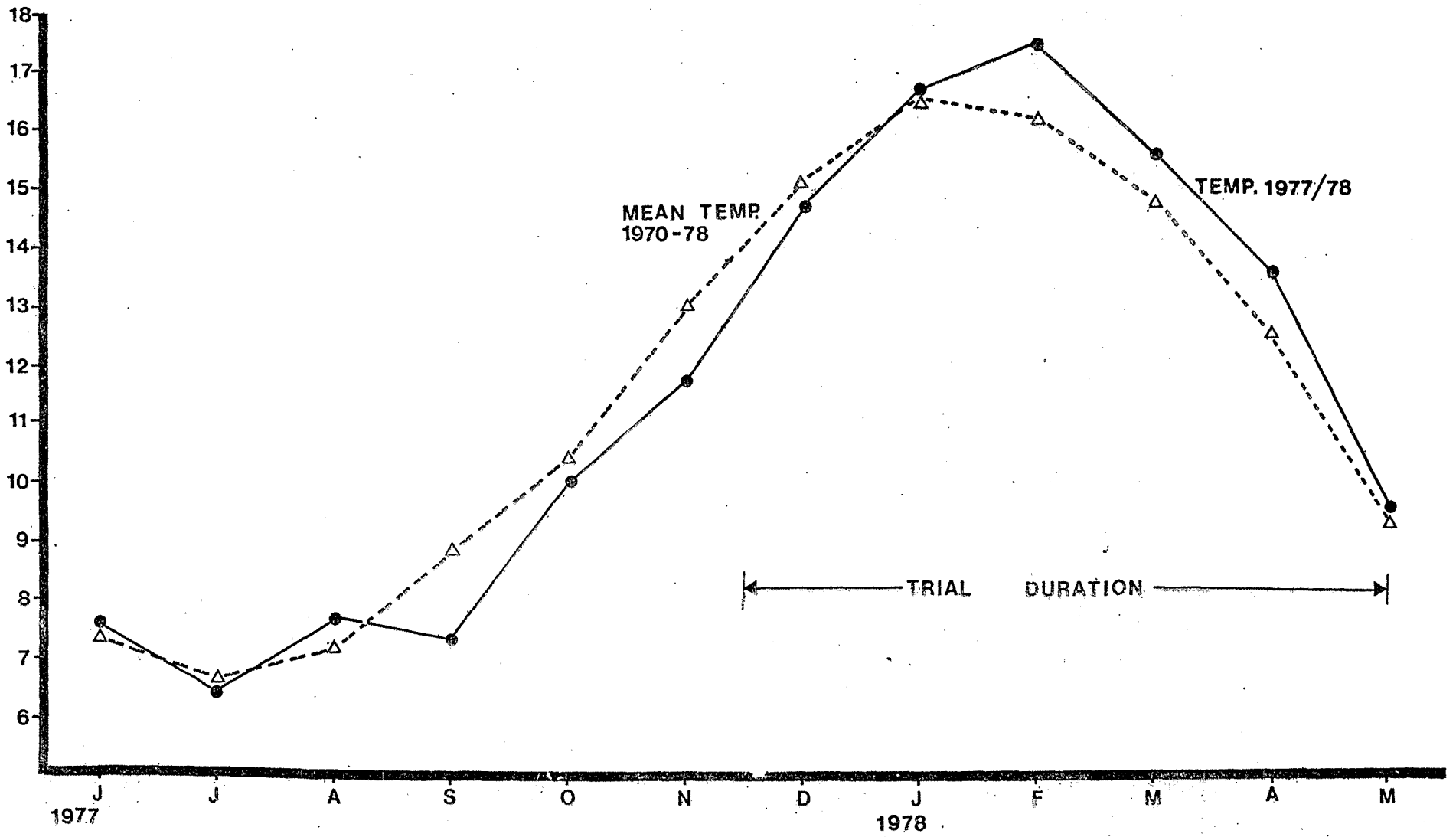
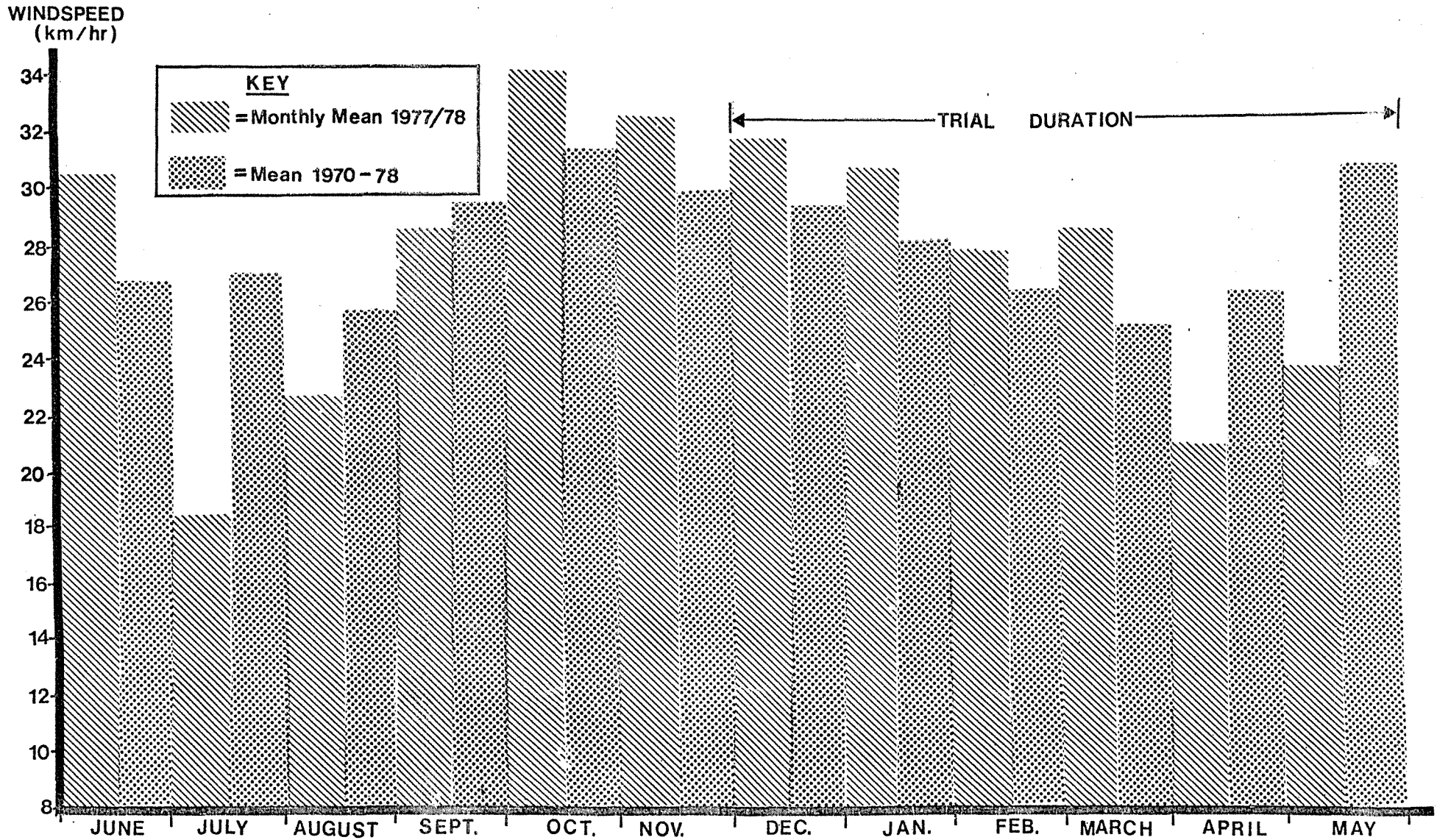

FIGURE 18

MEAN MONTHLY WINDRUN



The same climate parameters (viz. rainfall, 10 cm. soil temperature and windrun) are presented in Appendix 81 for the actual measurement three-day grazing periods.

CHAPTER 4.DISCUSSION

I. Experimental Objective The objective of this experiment was to investigate some basic factors influencing the grazing behaviour of sheep. Experimental layout and methods were designed to initiate investigations into the area of diet selection and diet quality under a sheep management system of rotational grazing. Such a basic study in grazing behaviour was opportune due to increasing advocacy of rotational grazing in pastoral management systems. It was conjectured that animal behaviour and pasture availability, quality and utilization, would vary over the grazing period. These phenomena were investigated under two seasons (summer and autumn), which provided varying levels of pasture availability, composition and quality; and under two stocking rates which provided differences of pasture utilization, composition and quality, but non-significant differences in diet selection.

As a consequence of the drought, the percentage of available pasture as dead matter increased markedly, pasture quality declined and the experimental animals experienced difficulty in maintaining liveweight and condition. A resulting decision from this situation was to temporarily end the experiment after Period III, harvest and remove the rank dead pasture, and recommence the experiment in the autumn after rains, at the same stocking rates. The resulting autumn pasture growth, availability and structure provided an interesting contrast to the summer pasture situation. During the interval between

the measurement seasons the experimental animals were maintained on pasture near the trial site.

The experiment was successful in its objectives, contributing to scientific and agricultural knowledge of animal behaviour at the pasture-animal interface.

II. Experimental Design A differential of 50% in stocking rates was imposed to produce a variation in pasture availability, quality and utilization. However the influence of these pasture characteristics did not produce a significant effect on the animals diet, as will be discussed more fully later.

Experimental size and design were limited by resource (viz. uniform land, materials, experimental animals and labour). Two replicates per treatment were considered minimal, as was four sheep per plot for "normal" behaviour. Familiarity with the management system and experimental sampling, and the closeness of the other animal groups, facilitated the achievement of "normal" behaviour, where "normal" behaviour in this context refers to the settled and contented behaviour of the animals, with no obvious signs of stress, or unusual behaviour.

Two oesophageal fistulated sheep per plot in the autumn were minimal with the summer situation of three O.F. sheep per plot being more desirable for obtaining representative diet samples. The misadventure of one O.F. sheep in the interval between the summer and autumn measurement periods, resulted in the situation of not having three O.F. sheep available per replicate for the autumn periods. The three experimental periods per season

proved adequate in ascertaining significant treatment effects on most of the measured parameters.

III. Experimental Methods Parameters were measured to obtain a collective description of the pasture availability, structure, composition and quality, and animal diet. Limitations of time restricted the amount and depth of some measurements (eg. day 2 pasture and animal extrusa samples were collected but not analysed; the summer pasture availability, composition and quality were stratified only into two strata; digestibility analyses were not performed on the dissected pasture and diet composition classes). The techniques employed were satisfactory in obtaining useful data on animal diet selection from the existing pasture conditions.

The literature review discussed the use of oesophageally fistulated animals and their reliability and acceptability in yielding dietary samples. The O.F. animals were randomised in each treatment (viz. between both replicates per treatment), at each sampling time. This procedure, along with the bulking of the extrusa from the O.F. animals within each plot, reduced the influence of any inherent variability between the animals. The technique employed of collecting bolus extrusa from the ground, markedly reduced the influence of saliva and its nitrogen content on the extrusa sample digestibility (Alder 1969; Hodgson and Rodriguez 1970; Langlands 1975).

Hand dissection of the freeze-dried diet samples into the morphological classification was affected successfully. This is reinforced by the lack of an

unidentifiable classification and the non-significant statistical difference between replicate analyses. This method is tedious and time consuming but results are reliable and quantifiable.

Dietary samples on day 3, especially during the summer season, were obtained with some difficulty. The O.F. animals would occasionally spend a high proportion of the normal collection time ruminating; this behaviour being attributed to the "unattractiveness" of the low quality diet, sward structure, the time of day and sometimes high temperatures. However samples were obtained, even if the sampling time had to be increased by 10-15 minutes.

The size and colour, as well as composition and quality, of the bolus material changed over the grazing period. Plate 7 illustrates this difference, in the autumn, of bolus colour, size and composition. Taylor and Deriaz (1963) observed this colour change even more so over their grazing duration with fistulated cattle. The colour changed as a result of composition, quality and degree of mastication.

IV. Experimental Results Contrasting pasture conditions were presented to the grazing animals during the summer and autumn seasons. Reproductive development by the grass species, and the transformation of green pasture into dead matter intensified over the summer season. Pasture availability was high, and sward structure was affected by these changes, resulting in the sheep being presented with a changing pasture availability, composition and profile. In the autumn following rains, the sheep were presented another pasture type and structure. Dead stubble was



PLATE 7. Animal bolus extrusa

Day 1

Day 2

Day 3



PLATE 8. Autumn pasture availability, a comparison of before and after grazing (Treatment H. 19-5-78)

decomposing and fresh green growth, and thus green matter availability, was increasing as the season progressed (Plate 8).

It is appropriate that the results of this experiment be discussed in the context of the effect of those pasture properties on the composition and quality of the animal diet and the effects of the animals on the pasture parameters. The environment can also influence the grazing behaviour of animals; but in this experiment weather conditions during the experimental measurement periods were favourable (Appendix 81). The principal influence of the climate was reflected through the pasture, rather than the climate having a direct influence on animal behaviour. As previously discussed the drought produced a summer pasture type of low quality and high dry matter contents, with increasing proportions of dead matter. The main autumn climatic influence on the pasture was to initiate fresh pasture growth of high quality and increase the rate of decomposition of the dead stubble.

The following discussion centres around the composition and quality of the sheep's diet as influenced by the pasture conditions and length of grazing period. The influence of stocking rate on the pasture parameters and animal diet will also be discussed.

A. Animal Diet (1) Composition

The results highlighted the grazing sheep's preference for green leaf; a result which is supported by much overseas research (eg. Arnold 1964; Hodgson 1975; Hamilton, Hutchinson, Annis and Donnelly 1973; Langlands

1975). Variations in the green leaf composition of the diet occurred during this experiment, decreasing as the percentage of dead material in the pasture increased; a correlation advocated by many other researchers (eg. Milford 1960; Arnold, Ball, McManus and Bush 1966; Alder 1969; Hamilton et al. 1973); and increasing in the late autumn as green leaf availability and accessibility improved. The overwhelming evidence of diet selection by sheep for green leaf under those variety of pasture conditions reinforces the importance of maintaining pastures in a fresh, rapidly growing, vegetative state as much as possible.

Green stem, as a diet component, decreased from 8% to 0.4% over the experimental duration, presumably because of its increasing maturity and unattractiveness to the grazing sheep (Arnold 1964, 1964d; Demarquilly and Jarrige 1973). The comparisons of pasture and diet stem compositions (Table 12), show the low preference rating of green stem. This is at variance with some Australian research results (Arnold 1964; Arnold Ball, McManus, and Bush 1966) which showed green stem to be an important component of the diet. However, it should be noted that the green stem in this study was mature, with many of the grass species being in full flower at the commencement of this experiment.

Weed species composed a very small portion of the diet, and based on Petrides' (1975) scale would be considered a very low ranking preference component of the grazing sheeps' diet.

The dietary composition of dead matter appeared to be correlated to the availability of dead matter in the

pasture (Table 12). The highly significant increase in intake of dead matter over the three-day grazing periods, was presumably caused by the accessibility problem encountered by the sheep attempting to select green leaf. These accessibility problems obviously occurred because the more accessible green leaves were grazed earlier in the grazing period. Many researchers (Milford 1960; Hamilton et al. 1973; Arnold et al. 1966; Alder 1969) have observed the diet selection by sheep under pasture conditions of increasing dry material. In situations where animals are unable to eat an entirely green diet, either dead matter composition of the diet increases (as evidenced in this trial), or the animals decrease their total intake to avoid eating dry material.

As the animal diet was not analysed for species composition, inferences of species preference exhibited by the sheep can only be drawn from the pasture species composition data, which was obtained primarily to provide a botanical description of the pasture. Lolium perenne was the major contributing pasture species and appeared to be a preferred component of the diet as indicated by its significant reduction in amount between day 1 and day 3. However, Petrides (1975) made the supposition that "principal foods" which are eaten in the greatest quantities by an animal population, are not necessarily preferred foods. Agrostis tenuis exhibited a similar trend of decreasing availability over the three-day grazing periods, while the Trifolium species were the only other group to show this trend and infer diet preference.

(2) Digestibility

The slower rate of decline in the digestibility of the diet compared to the digestibility of the pasture over the summer, was attributed to selective grazing; a phenomenon experienced also by Arnold (1964). The diet digestibility increased during the autumn as a result of a decreasing percentage of dead matter in the sward. The fact that the green leaf was young would also have attributed to the high levels of pasture digestibility in the autumn (Terry and Tilley 1964).

The higher digestibility of the diet on day 1 compared to day 3 also indicated that the sheep were able to graze more selectively at the beginning compared with the end of the three-day grazing periods. The lower digestibility of the diet at the end of the three-day grazing periods would have been markedly influenced by sward structure and its influence on accessibility of green leaf, and the lower availability of green leaf because of its high preference causing its rapid decline in availability over the grazing period.

Significantly greater digestibility values of the diet compared to digestibility values of the pasture, reinforce the demonstration of selective grazing behaviour by sheep in this trial. As previously mentioned, diet digestibility values can be biased by saliva contamination. The collection technique of collecting boluses off the ground, avoided a large amount of saliva contamination which occurs in bag collection techniques, and therefore would not negate these significant differences (mean 13%) between pasture and diet digestibility.

B. Stocking Rate

The effects of stocking rate, reflected through grazing pressures, influenced pasture availability. The higher stocked treatment had significantly less total dry matter, green matter and dead matter, available than the lower stocked treatment. These situations are illustrated in Plates 9 and 10 for the summer season, and Plates 11 and 12 (post-grazing only) for the autumn season.

Stocking rate did not significantly affect the availability of green leaf, but the higher stocked treatment had significantly less green stem than the L treatment. The greater grazing pressure of the H treatment presumably reduced the development of green stem, although the possibility of greater amounts of green stem being classified as dead matter in the H treatment may also have occurred. Both stocking rates, during the summer season were unable to maintain a reasonable quality sward, especially more so for the L pasture which had a lower mean digestibility than the H pasture. The dead matter content of the L pasture either increased at a faster rate than in the H pasture and/or did not decompose as fast.

The higher (H) stocking rate treatment had a mean 5% greater organic matter digestibility value than the L treatment at the beginning of the grazing periods. As there was no significant overall differences in percentage pasture composition between stocking rate treatments, this result would seem to occur because of more young pasture regrowth in the H compared with the L treatment.



PLATE 9. Late-Summer pasture availability - Treatment L (6-3-78)
 (a) Before grazing (b) After grazing.



PLATE 10. Late-Summer pasture availability - Treatment H (6-3-78)
 (a) After grazing (b) Before grazing



PLATE 11. Post-grazing autumn pasture availability
- Treatment H. (19-5-78)



PLATE 12. Post-grazing autumn pasture availability
- Treatment L. (19-5-78)

The 50% difference in stocking rate did not have a significant effect on diet composition. Similarly there was not a significant difference between the digestibilities of the diets between treatments, although the H digestibility values were slightly higher than the L digestibilities. Yet, as previously discussed, pasture availabilities and pasture compositions differed between the two treatments. The interpretation of these results must be that the grazing sheep, through their selective grazing and diet preference for green leaf, were still able to satisfy their diet preferences even though differences of grazing pressure and pasture conditions existed. These results are likely because the amount of green leaf, the preferred diet component, did not significantly differ between treatments.

V. General Conclusions and Practical Implications

The experiment provided a sound data base in the field of grazing management and diet selection by sheep being rotationally grazed on pasture, and certainly proved to be heuristic, illuminating spheres of grazing behaviour and management that need further investigation. As discussed, the results confirm and support many of the conclusions of previous researchers (eg. Arnold 1960, 1964; Arnold, Ball, McManus and Bush 1966; Langlands 1975; Hamilton, Hutchinson, Annis and Donnelly 1973).

The grazing behaviour of the sheep, as measured by the use of oesophageally fistulated sheep and pasture sampling techniques, was shown to be highly selective. Pasture availability and accessibility of the green leaf component

decreased over the grazing three-day periods, climatic conditions markedly affected the pasture composition and pasture growth, and provided swards over the two seasons (summer and autumn) of varying composition, quality and availability. Although stocking rate affected pasture conditions, it did not affect animal diet preferences which were exhibited strongly for green leaf and against mature green stem and dead matter. The digestibility of the diet was improved as the amount and accessibility of the pasture green leaf component increased.

Practical management implications arise from these results. Pasture quality decreases from the onset of reproductive development, and in the advent of dry summer conditions, declines rapidly as the green stem matures and the percentage of dead matter increases. This implies the necessity to maintain pastures in a vegetative state to maintain quality, and the impractical nature of any management policy which attempts to "carry forward standing hay" (rank grass in situ) into the late summer, autumn and even winter seasons. Not only does the low and declining digestibility of this rank pasture indicate the inefficiency of this policy but also the results of this animal diet study show the sheeps' marked rejection of this material, and associated problems of accessibility to preferred green leaf. Likewise swards of high dead matter content are prone to produce animal disorders of facial eczema, and/or ryegrass staggers, and to seriously affect light penetration to the base of the sward and tiller initiation. It is appreciated that in most grassland situations, in New Zealand, late spring

/early summer pasture production is in excess of the immediate animal feed requirements, especially in the lower stocked situations. However there are better methods of feed conservation (eg. silage, hay), and pasture utilization (eg. higher stocking rates, offspring production, pasture management and animal type manipulation) resulting in higher animal product output per hectare, induced from better pasture utilization, growth and quality, than from the "in situ rank summer conservation practice".

Pasture digestibility, which reflects pasture quality (in low and medium quality pastures), influences feed intake and thus animal performance (Hodgson 1977; Rodriguez and Hodgson 1974; Arnold et al. 1964). Thus efficient animal production from pasture results from management practices which maintain pasture quality and thus high levels of digestibility. The conclusive results of the diet preference of sheep for high quality green material (leaf) reinforces the importance of managing pastures in the high quality, actively growing, vegetative state.

APPENDIX 1

PASTURE AVAILABILITY - TOTAL (kg/ha)

P E R I O D	T R E A T M E N T	Rep. A.		Rep. B.	
		Days		Days	
		1	3	1	3
I	L	6007	5254	5464	4706
	H	4582	4236	3485	2645
II	L	5419	5196	6438	4004
	H	3382	3255	4194	3046
III	L	5351	4868	5737	7561
	H	2932	3242	4575	2529
IV	L	2793	2074	2196	1983
	H	1878	1815	2257	1551
V	L	2165	1070	2191	1294
	H	2008	824	1465	700
VI	L	1615	882	1580	767
	H	1350	423	1486	516

PASTURE AVAILABILITY - TOTAL

Source	SS	DF	MS	F
Reps	1312.52	1	1312.52	.335739E-2 ns
Days	.540625E 7	1	.540625E 7	13.829 ***
Periods	.109917E 9	5	.219834E 8	56.2328 ***
DaysxPeriods	.123995E 7	5	247990	.634351 ns
Trts	.166134E 8	1	.166134E 8	42.4965 ***
DaysxTrts	47817.2	1	47817.2	.122315 ns
PeriodsxTrts	.900131E 7	5	.180026E 7	4.60501 **
Error 1	.109462E 8	28	390935	

Overall Mean = 3020.65

Treatments Means:

	Reps	Days	Periods	Trts
1	3025.87	3356.25	4547.37	3608.96
2	3015.42	2685.04	4366.75	2432.33
3			4599.38	
4			2068.38	
5			1464.62	
6			1077.37	
L.S.D. 5%	369.724	369.724	640.38	369.724
L.S.D. 1%	498.751	498.751	863.863	498.751
L.S.D. .1%	663.109	663.109	1148.54	663.109

Differences between means for Reps

2	
1	ns

Differences between means for Days

2	
1	***

Differences between means for Periods

	2	3	4	5	6
1	ns	ns	***	***	***
2		ns	***	***	***
3			***	***	***
4				ns	**
5					ns

Differences between means for Trts

2	
1	***

APPENDIX 3.

PASTURE AVAILABILITY - GREEN MATTER (kg/ha)

P E R I O D	T R E A T M E N T	REP. A.		REP. B.	
		Days		Days	
		1	3	1	3
I	L	5290	4638	4442	3821
	H	4217	3714	3050	2282
II	L	4590	3767	4500	2676
	H	2948	2323	3378	2209
III	L	1689	1864	1784	3033
	H	1218	1068	1651	473
IV	L	876	454	772	356
	H	397	190	664	146
V	L	1136	497	1358	830
	H	1352	470	966	279
VI	L	1272	502	1072	452
	H	1003	225	1262	335

APPENDIX 4.

PASTURE AVAILABILITY - GREEN MATTER

Source	SS	DF	MS	F	
Reps	318339	1	318339	1.79711	ns
Days	.425009E 7	1	.425009E 7	23.9928	***
Periods	.841481E 8	5	.168296E 8	95.0075	***
DaysxPeriods	.146383E 7	5	292766	1.65274	ns
Trts	.523446E 7	1	.523446E 7	29.5499	***
DaysxTrts	130313	1	130313	.735647	ns
PeriodsxTrts	.273308E 7	5	546617	3.08579	*
Error 1	.495992E 7	28	177140		

Overall Mean = 1822.73

Treatment Means:

	Reps	Days	Periods	Trts
1	1904.17	2120.29	3931.75	2152.96
2	1741.29	1525.17	3298.88	1492.5
3			1597.5	
4			481.875	
5			861	
6			765.375	
L.S.D. 5%	248.876	248.876	431.066	248.876
L.S.D. 1%	335.73	335.73	581.501	335.73
L.S.D. .1%	446.366	446.366	773.128	446.366

Differences between means for Reps

	2
1	ns

Differences between means for Days

	2
1	***

Differences between means for Periods

	2	3	4	5	6
1	**	***	***	***	***
2		***	***	***	***
3			***	**	***
4				ns	ns
5					ns

Differences between means for Trts

	2
1	***

APPENDIX 5

PASTURE AVAILABILITY - DEAD MATTER (kg/ha)

P E R I O D	T R E A T M E N T	REP. A.		REP. B.	
		Days		Days	
		1	3	1	3
I	L	717	616	1022	885
	H	365	522	435	463
II	L	829	1429	1938	1328
	H	434	932	816	837
III	L	3662	3004	3953	4528
	H	1714	2174	2924	2056
IV	L	1917	1620	1424	1628
	H	1481	1625	1593	1406
V	L	1029	573	833	464
	H	656	354	499	421
VI	L	343	380	508	315
	H	347	198	224	181

APPENDIX 6

PASTURE AVAILABILITY - DEAD MATTER

Source	SS	DF	MS	F	
Reps	294533	1	294533	3.03344	ns
Days	61920.3	1	61920.3	.637726	ns
Periods	.390803E 8	5	.781605E 7	80.4987	***
Days x Periods	199904	5	39980.8	.411768	ns
Trts	.314573E 7	1	.314573E 7	32.3983	***
Days x Trts	24570.8	1	24570.8	.253058	ns
Periods x Trts	.302256E 7	5	604513	6.22596	***
Error 1	.271867E 7	28	97095.5		

Overall Mean = 1200.04

Treatment Means:

	Reps	Days	Periods	Trts
1	1121.71	1235.96	628.125	1456.04
2	1278.38	1164.13	1067.88	944.042
3			3001.88	
4			1586.75	
5			603.625	
6			312	
L.S.D. 5%	184.257	184.257	319.143	184.257
L.S.D. 1%	248.56	248.56	430.518	248.56
L.S.D. .1%	330.47	330.47	572.391	330.47

Differences between means for Reps

2	
1	ns

Differences between means for Days

2	
1	ns

Differences between means for Periods

	2	3	4	5	6
1	**	***	***	ns	ns
2		***	**	**	***
3			***	***	***
4				***	***
5					ns

Differences between means for Trts

2	
1	***

APPENDIX 7.

STRATA PASTURE AVAILABILITY - TOTAL (kg/ha)

P E R I O D	T R E A T M E N T	S T R A T A	REP. A.		REP. B.		
			Days		Days		
			1	3	1	3	
I	L	T	2268	1958	1217	1608	
		B	3739	3296	4247	3098	
	H	T	784	1223	463	587	
		B	3798	3013	3022	2058	
	II	L	T	2057	2369	1521	1226
			B	3362	2827	4917	2778
H		T	945	963	1143	718	
		B	2437	2292	3051	2328	
III	L	T	2195	1500	2276	2300	
		B	3156	3368	3461	5261	
	H	T	674	475	1383	588	
		B	2258	2767	3192	1941	

NB. T \geq 100 mm above ground level
 B \leq 100 mm below ground level

APPENDIX 8.

STRATA PASTURE AVAILABILITY - TOTAL

Source	SS	DF	MS	F
Reps	9075	1	9075	.276694E-1 ns
Days	.102785E 7	1	.102785E 7	3.13387 ns
Periods	119258	2	59629.2	.181808 ns
DaysxPeriods	402808	2	201404	.614076 ns
Trts	.119022E 8	1	.119022E 8	36.2895 ***
DaysxTrts	39102.1	1	39102.1	.119221 ns
PeriodsxTrts	498976	2	249488	.760681 ns
Strata	.389268E 8	1	.389268E 8	118.687 ***
DaysxStrata	367850	1	367850	1.12156 ns
PeriodsxStrata	317513	2	158757	.484045 ns
TrtsxStrata	29800.3	1	29800.3	.908604E-1 ns
Error 1	.104963E 8	32	327979	

Overall Mean = 2252.25

Treatment Means:

	Rep	Days	Periods	Trts	Strata
1	2238.5	2398.58	2273.69	2750.21	1351.71
2	2266	2105.92	2183.38	1754.29	3152.79
3			2299.69		
L.S.D. 5%	336.751	336.751	412.434	336.751	336.751
L.S.D. 1%	452.734	452.734	554.483	452.734	452.734
L.S.D. .1%	598.76	598.76	733.329	598.76	598.76

Differences between means for Reps

	2
1	ns

Differences between means for Days

	2
1	ns

Differences between means for Periods

	2	3
1	ns	ns
2		ns

Differences between means for Trts

	2
1	***

Differences between means for Strata

	2
1	***

APPENDIX 9

STRATA PASTURE AVAILABILITY - GREEN MATTER (kg/ha)

P E R I O D	T R E A T M E N T	S T R A T A	REP. A.		REP. B.	
			Days		Days	
			1	3	1	3
I	L	T	2259	1938	1160	1523
		B	3031	2700	3282	2298
	H	T	780	1208	457	574
		B	3437	2506	2593	1608
II	L	T	1973	2065	1278	931
		B	2617	1702	3222	1745
	H	T	917	873	1100	661
		B	2031	1450	2278	1548
III	L	T	542	371	630	2121
		B	1147	1493	1154	2521
	H	T	333	95	165	48
		B	885	973	1486	425

APPENDIX 10

STRATA PASTURE AVAILABILITY - GREEN MATTER (kg/ha)

Source	SS	DF	MS	F	
Reps	132090	1	132090	.597717	ns
Days	603008	1	603008	2.72866	ns
Periods	.951022E 7	2	.475511E 7	21.5172	***
DaysxPeriods	.124826E 7	2	624128	2.82423	ns
Trts	.485904E 7	1	.485904E 7	21.9875	***
DaysxTrts	270901	1	270901	1.22585	ns
PeriodsxTrts	25344.3	2	12672.1	.573424E-1	ns
Strata	.121304E 8	1	.121304E 8	54.8907	***
DaysxStrata	.102317E 7	1	.102317E 7	4.62991	*
PeriodsxStrata	.118902E 7	2	594512	2.69021	ns
TrtsxStrata	314928	1	314928	1.42507	ns
Error 1	.707171E 7	32	220991		

Overall Mean = 1502.79

Treatment Means:

	Reps	Days	Periods	Trts	Strata
1	1555.25	1614.88	1959.62	1820.96	1000.08
2	1450.33	1390.71	1649.44	1184.63	2005.5
3			899.312		
L.S.D. 5%	276.422	276.422	338.546	276.422	276.422
L.S.D. 1%	371.626	371.626	455.148	371.626	371.626
L.S.D. .1%	491.493	491.493	601.953	491.493	491.493

Differences between means for Reps

2	
1	ns

Differences between means for Days

2	
1	ns

Differences between means for Periods

2		3	
1	ns	***	
2		***	

Differences between means for Trts

2	
1	***

Differences between means for Strata

2	
1	***

APPENDIX 11

STRATA PASTURE AVAILABILITY - DEAD MATTER (kg/ha)

P E R I O D	T R E A T M E N T	S T R A T A	REP. A.		REP. B.	
			Days		Days	
			1	3	1	3
I	L	T	9	20	57	85
		B	708	596	965	800
	H	T	4	15	6	13
		B	361	507	429	450
II	L	T	84	304	243	295
		B	745	1125	1695	1033
	H	T	28	90	43	57
		B	406	842	773	780
III	L	T	1653	1129	1646	179
		B	2009	1875	2307	2740
	H	T	341	380	1218	540
		B	1373	1794	1706	1516

APPENDIX 12

STRATA PASTURE AVAILABILITY - DEAD MATTER (kg/ha)

Source	SS	DF	MS	F
Reps	210410	1	210410	2.7412 ns
Days	56307	1	56307	.733561 ns
Periods	.105554E 8	2	.527769E 7	68.7571 ***
DaysxPeriods	235686	2	117843	1.53525 ns
Trts	.15516E 7	1	.15516E 7	20.2141 ***
DaysxTrts	104160	1	104160	1.35699 ns
PeriodsxTrts	335957	2	167979	2.18841 ns
Strata	.759703E 7	1	.759703E 7	98.9732 ***
DaysxStrata	164034	1	164034	2.13702 ns
PeriodsxStrata	412239	2	206120	2.6853 ns
TrtsxStrata	150976	1	150976	1.9669 ns
Error 1	.245627E 7	32	76758.4	

Overall Mean = 749.458

Treatment Means:

	Reps	Days	Periods	Trts	Strata
1	683.25	783.708	314.062	929.25	351.625
2	815.667	715.208	533.938	569.667	1147.29
3			1400.38		
L.S.D. 5%	162.91	162.91	199.523	162.91	162.91
L.S.D. 1%	219.019	219.019	268.243	219.019	219.019
L.S.D. .1%	289.663	289.663	354.763	289.663	289.663

Differences between means for Reps

	2
1	ns

Differences between means for Days

	2
1	ns

Differences between means for Periods

	2	3
1	*	***
2		***

Differences between means for Trts

	2
1	***

Differences between means for Strata

	2
1	***

APPENDIX 13.

PASTURE UTILIZATION

Source	SS	DF	MS	F
Season	1615.96	1	1615.96	12.2984 *
Trts	106.337	1	106.337	.809287 ns
SeasonxTrts	8.47346	1	8.47346	.644881E-1 ns
Reps	161.7	1	161.7	1.23064 ns
Error 1	394.187	3	131.396	.266514 ns
Subsamples	7888.26	16	493.016	
Subsamples	7888.26	16	493.016	

Overall Mean = 27.7625

Treatment Means:

	Season	Trts	Reps
1	13.55	24.1167	23.2667
2	41.975	31.4083	32.2583
L.S.D. 5%	25.7639	25.7639	25.7639
L.S.D. 1%	46.9704	46.9704	46.9704
L.S.D. .1%	100.395	100.395	100.395

Differences between means for Season

2	
<hr/>	
1	*
<hr/>	

Differences between means for Trts

2	
<hr/>	
1	ns
<hr/>	

Differences between means for Reps

2	
<hr/>	
1	ns
<hr/>	

APPENDIX 14.

PERCENTAGE STRATA UTILIZATION - TOTAL AVAILABLE HERBAGE

Source	SS	DF	MS	F
Trts	65.9335	1	65.9335	.227464 ns
Strata	127.733	1	127.733	.440667 ns
TrtsxStrata	7.15681	1	7.15681	.246902E-1 ns
Reps	225.073	1	225.073	.77648 ns
Error 1	869.592	3	289.864	.282539 ns
Subsamples	16414.8	16	1025.93	
Subsamples	16414.8	16	1025.93	

Overall Mean = 8.65417

Treatment Means

	Trts	Strata	Reps
1	5.78333	4.65833	3.35
2	11.525	12.65	13.9583
L.S.D. 5%	38.2665	38.2665	38.2665
L.S.D. 1%	69.7639	69.7639	69.7639
L.S.D. .1%	149.113	149.113	149.113

Differences between means for Trts

	2
<hr/>	
1	ns
<hr/>	

Differences between means for Strata

	2
<hr/>	
1	ns
<hr/>	

Differences between means for Reps

	2
<hr/>	
1	ns
<hr/>	

APPENDIX 15.

PASTURE COMPOSITION (%)

P E R I O D	D A Y S	T R E A T M E N T	% REP. A.				% REP. B.			
			L	S	OS	D	L	S	OS	D
I	1	L	22.27	70.32	2.70	4.70	11.29	77.38	2.51	8.80
		H	27.76	66.69	2.32	3.22	12.30	82.81	1.18	3.70
	3	L	12.72	77.82	2.78	6.66	20.67	60.52	0.61	18.53
		H	10.83	83.31	1.86	3.98	16.27	71.22	5.30	7.24
II	1	L	10.11	81.06	0.84	7.97	16.43	62.78	0.99	19.78
		H	15.58	73.95	4.26	6.20	21.01	64.16	5.86	9.33
	3	L	13.28	61.71	0.78	24.22	8.62	62.88	0.47	28.01
		H	7.78	76.76	1.65	13.79	5.65	79.37	1.72	13.24
III	1	L	9.34	13.88	4.35	72.41	8.45	21.10	0.58	69.85
		H	7.37	37.07	1.48	54.06	5.66	13.93	0.14	80.25
	3	L	4.39	22.90	0.75	71.94	6.19	20.90	0.00	72.89
		H	8.16	16.50	0.36	74.95	2.47	7.73	0.33	89.45
IV	1	L	20.40	7.40	3.54	68.64	23.91	9.41	1.80	64.85
		H	17.73	3.04	0.33	78.87	18.35	10.56	0.38	70.60
	3	L	10.93	10.44	0.52	78.09	10.48	7.42	0.00	82.09
		H	6.14	4.30	0.00	89.54	4.26	5.10	0.00	90.63
V	1	L	41.30	10.69	0.47	47.54	47.76	12.93	1.24	38.04
		H	55.58	8.27	3.46	32.66	60.14	3.34	2.43	34.07
	3	L	32.31	14.10	0.00	53.58	49.82	13.10	1.17	35.89
		H	39.52	13.78	3.69	42.99	24.18	15.60	0.00	60.20
VI	1	L	72.17	6.07	0.48	21.26	59.22	8.06	0.52	32.18
		H	69.48	4.77	0.00	25.73	76.92	6.13	1.84	15.09
	3	L	47.60	8.83	0.43	43.12	51.81	7.07	0.02	41.08
		H	39.14	13.77	0.29	46.78	47.46	16.36	1.09	35.07

PASTURE COMPOSITION (kg/ha)

P E R I O D	D A Y S	T R E A T M E N T	REP. A.				REP. B.			
			L	S	OS	D	L	S	OS	D
I.	1	L	1715.9	3247.6	325.9	716.8	888.5	3287.8	264.0	1022.7
		H	1744.2	2368.4	102.4	365.7	1395.5	1594.6	50.4	434.4
	3	L	890.7	3519.9	225.5	616.4	981.3	2827.7	27.7	884.9
		H	937.3	2707.2	68.1	522.4	786.8	1167.4	231.2	463.0
II	1	L	1051.4	3473.4	64.0	828.9	1580.0	2789.4	129.9	1937.8
		H	1183.1	1584.5	179.7	433.8	1446.0	1739.2	237.4	815.4
	3	L	707.9	3017.8	40.6	1428.8	742.4	2047.0	38.7	1328.2
		H	591.3	1573.3	157.2	932.6	635.2	1654.3	41.9	837.3
III	1	L	648.2	796.1	245.7	3661.6	527.9	1209.0	46.4	3952.6
		H	396.0	756.3	65.2	1713.9	650.5	978.6	20.4	2924.4
	3	L	414.8	1299.9	148.2	3003.8	701.2	2330.8	0.0	4528.0
		H	405.1	631.9	30.7	2173.7	175.0	260.3	37.8	2055.2
IV	1	L	569.8	206.7	98.9	1917.1	525.1	206.6	39.5	1424.1
		H	333.0	57.1	6.2	1481.2	414.2	238.3	8.6	1593.4
	3	L	226.7	216.5	10.8	1619.6	207.8	147.1	0.0	1627.8
		H	111.4	78.0	0.0	1625.2	66.1	79.1	0.0	1405.7
V	1	L	894.1	231.4	10.2	1029.2	1046.4	283.3	27.2	833.5
		H	1116.0	166.1	69.5	655.8	881.1	48.9	35.6	499.1
	3	L	345.7	150.9	0.0	573.3	644.6	169.5	15.1	464.4
		H	325.6	113.5	30.4	354.2	169.3	109.2	0.0	421.4
VI	1	L	1165.5	98.0	7.7	343.3	935.7	127.3	8.2	508.4
		H	938.0	64.4	0.0	347.4	1143.0	91.1	27.3	224.2
	3	L	419.8	77.9	3.8	380.3	397.4	54.2	0.2	315.1
		H	165.6	58.2	1.2	197.9	244.9	84.4	5.6	181.0

APPENDIX 17.

PASTURE COMPOSITION - % LEAF

Reps	1.15012	1	1.15012	.335981E-1 ns
Periods	17063.6	5	3412.72	99.6947 ***
Days	1300.52	1	1300.52	37.9918 ***
PeriodsxDays	611.513	5	122.303	3.57279 *
Trts	2.86652	1	2.86652	.837388E-1 ns
PeriodsxTrts	55.5679	5	11.1136	.324658 ns
DaysxTrts	217.558	1	217.558	6.35547 *
Error 1	958.487	28	34.2317	

Overall Mean = 25.2335

Treatment Means:

	Reps	Periods	Days	Trts
1	25.0788	16.7638	30.4388	25.4779
2	25.3883	12.3075	20.0283	24.9892
3		6.50375		
4		14.025		
5		43.8263		
6		57.975		
L.S.D. 5%	3.4597	5.99238	3.4597	3.4597
L.S.D. 1%	4.66708	8.08363	4.66708	4.66708
L.S.D. .1%	6.20507	10.7475	6.20507	6.20507

Differences between means for Reps

2	
1	ns

Differences between means for Periods

	2	3	4	5	6
1	ns	**	ns	***	***
2		ns	ns	***	***
3			*	***	***
4				***	***
5					***

Differences between means for Days

2	
1	***

Differences between means for Trts

2	
1	ns

APPENDIX 18.

PASTURE COMPOSITION - % STEM

Source	SS	DF	MS	F	
Reps	47.144	1	47.144	.992081	ns
Periods	39566.8	5	7913.36	166.526	***
Days	5.12869	1	5.12869	.107926	ns
PeriodsxDays	151.023	5	30.2045	.635613	ns
Trts	18.4388	1	18.4388	.388019	ns
PeriodsxTrts	151.088	5	30.2176	.635889	ns
DaysxTrts	37.5771	1	37.5771	.790759	ns
Error 1	1330.57	28	47.5203		

Overall Mean = 31.8185

Treatment Means:

	Reps	Periods	Days	Trts
1	32.8096	73.7588	31.4917	31.1988
2	30.8275	70.3338	32.1454	32.4383
3		19.2513		
4		7.20875		
5		11.4763		
6		8.8825		
L.S.D. 5%	4.07628	7.06033	4.07628	4.07628
L.S.D. 1%	5.49884	9.52427	5.49884	5.49884
L.S.D. .1%	7.31092	12.6629	7.31092	7.31092

Differences between means for Reps

2	
1	ns

Differences between means for Periods

	2	3	4	5	6
1	ns	***	***	***	***
2		***	***	***	***
3			**	*	**
4				ns	ns
5					ns

Differences between means for Days

2	
1	ns

Differences between means for Trts

2	
1	ns

APPENDIX 19.

PASTURE COMPOSITION - % OTHER SPECIES

Source	SS	DF	MS	F
Reps	1.06803	1	1.06803	.723847 ns
Periods	21.2191	5	4.24382	2.8762 *
Days	8.23364	1	8.23364	5.58023 *
PeriodsxDays	7.05827	5	1.41165	.956732 ns
Trts	3.21368	1	3.21368	2.17803 ns
PeriodsxTrts	21.6006	5	4.32012	2.92791 *
DaysxTrts	.541875	1	.541875	.36725 ns
Error 1	41.3139	28	1.4755	

Overall Mean = 1.40667

Treatment Means:

	Reps	Periods	Days	Trts
1	1.55583	2.4075	1.82083	1.14792
2	1.2575	2.07125	.9925	1.66542
3		.99875		
4		.82125		
5		1.5575		
6		.58375		
L.S.D. 5%	.71828	1.2441	.71828	.71828
L.S.D. 1%	.968948	1.67827	.968948	.968948
L.S.D. .1%	1.28825	2.23132	1.28825	1.28825

Differences between means for Reps

2	
1	ns

Differences between means for Periods

	2	3	4	5	6
1	ns	*	*	ns	**
2		ns	*	ns	*
3			ns	ns	ns
4				ns	ns
5					ns

Differences between means for Days

2	
1	*

Differences between means for Trts

2	
1	ns

APPENDIX 20.

PASTURE COMPOSITION - % DEAD MATTER

Source	SS	DF	MS	F
Reps	47.92	1	47.92	.981344 ns
Periods	34271.9	5	6854.38	140.37 ***
Days	1345.78	1	1345.78	27.5599 ***
PeriodsxDays	240.78	5	48.156	.986177 ns
Trts	19.3548	1	19.3548	.396363 ns
PeriodsxTrts	418.375	5	83.6751	1.71357 ns
DaysxTrts	60.75	1	60.75	1.24409 ns
Error 1	1367.27	28	48.8309	

Overall Mean = 41.5367

Treatment Means:

	Reps	Periods	Days	Trts
1	40.5375	7.10375	36.2417	42.1717
2	42.5358	15.3175	46.8317	40.9017
3		73.225		
4		77.9138		
5		43.1213		
6		32.5388		
L.S.D. 5%	4.13211	7.15703	4.13211	4.13211
L.S.D. 1%	5.57416	9.65472	5.57416	5.57416
L.S.D. .1%	7.41106	12.8363	7.41106	7.41106

Differences between means for Reps

	2
1	ns

Differences between means for Periods

	2	3	4	5	6
1	*	***	***	***	***
2		***	***	***	***
3			ns	***	***
4				***	***
5					**

Differences between means for Days

	2
1	***

Differences between means for Trts

	2
1	ns

APPENDIX 21.

PASTURE COMPOSITION - LEAF (kg/ha)

Source	SS	DF	MS	F	
Reps	257.61	1	257.61	.801996E-2	ns
Periods	.401414E 7	5	802828	24.9938	***
Days	.294783E 7	1	.294783E 7	91.7725	***
PeriodsxDays	530058	5	106012	3.30038	*
Trts	81230.1	1	91230.1	2.52887	ns
PeriodsxTrts	91837.6	5	18367.5	.571822	ns
DaysxTrts	97092.1	1	97092.1	3.02269	ns
Error 1	899390	28	32121.1		

Overall Mean = 718.396

Treatment Means:

	Reps	Periods	Days	Trts
1	720.713	1167.53	966.213	759.533
2	716.079	992.163	470.579	677.258
3		489.838		
4		306.763		
5		677.85		
6		676.238		
L.S.D. 5%	105.979	183.561	105.979	105.979
L.S.D. 1%	142.964	247.621	142.964	142.964
L.S.D. .1%	190.076	329.222	190.076	190.076

Differences between means for Reps

2	
1	ns

Differences between means for Periods

	2	3	4	5	6
1	ns	***	***	***	***
2		***	***	**	**
3			ns	*	*
4				***	***
5					ns

Differences between means for Days

2	
1	***

Differences between means for Trts

2	
1	ns

PASTURE COMPOSITION - STEM (kg/ha)

Reps	183757	1	183757	1.31983	ns
Periods	.504792E 8	5	.100958E 8	72.5133	***
Days	33501.7	1	33501.7	.240626	ns
PeriodsxDays	272165	5	54433.1	.390966	ns
Trts	.385985E 7	1	.385985E 7	27.7234	***
PeriodsxTrts	.333866E 7	5	667731	4.79598	**
DaysxTrts	23999.4	1	23999.4	.172376	ns
Error 1	.389836E 7	28	139227		

Overall Mean = 1042.09

Treatment Means:

	Reps	Periods	Days	Trts
1	1103.96	2590.08	1068.5	1325.66
2	980.213	2234.86	1015.67	758.513
3		1032.86		
4		153.675		
5		159.1		
6		81.9376		
L.S.D. 5%	220.641	382.162	220.641	220.641
L.S.D. 1%	297.642	515.53	297.642	297.642
L.S.D. .1%	395.726	685.418	395.726	395.726

Difference between means for Reps

	2
1	ns

Differences between means for Periods

	2	3	4	5	6
1	ns	***	***	***	***
2		***	***	***	***
3			***	***	***
4				ns	ns
5					ns

Differences between means for Days

	2
1	ns

Differences between means for Trts

	2
1	***

APPENDIX 23.

PASTURE COMPOSITION - OTHER SPECIES (kg/ha)

Source	SS	DF	MS	F	
Reps	7470.03	1	7470.03	2.04051	ns
Periods	149542	5	29908.5	8.16977	***
Days	19024.4	1	19024.4	5.19669	*
PeriodsxDays	6407.64	5	1281.53	.350061	ns
Trts	2973.71	1	2873.71	.784979	ns
PeriodsxTrts	44325.6	5	8865.12	2.42159	ns
DaysxTrts	6496.05	1	6496.05	1.77446	ns
Error 1	102504	28	3660.87		

Overall Mean = 66.3542

Treatment Means:

	Reps	Periods	Days	Trts
1	78.8292	161.9	86.2625	74.0917
2	53.8792	111.175	46.4458	58.6167
3		74.3		
4		20.5		
5		23.5		
6		6.75		
L.S.D. 5%	35.7781	61.9694	35.7781	35.7781
L.S.D. 1%	48.2641	83.5958	48.2641	48.2641
L.S.D. .1%	64.1689	111.144	64.1689	64.1689

Differences between means for Reps

2	
1	ns

Differences between means for Periods

	2	3	4	5	6
1	ns	**	***	***	***
2		ns	**	**	**
3			ns	ns	*
4				ns	ns
5					ns

Differences between means for Days

2	
1	*

Differences between means for Trts

2	
1	ns

PASTURE COMPOSITION - DEAD MATTER (kg/ha)

Source	SS	DF	MS	F	
Reps	294393	1	294393	3.03036	ns
Periods	.390673E 8	5	.781347E 7	80.4287	***
Days	61956.3	1	61956.3	.637753	ns
PeriodsxDays	200148	5	40029.6	.412048	ns
Trts	.314588E 7	1	.314588E 7	32.3825	***
PeriodsxTrts	.302215E 7	5	604431	6.22177	***
DaysxTrts	24584.3	1	24584.3	.253061	ns
Error 1	.272014E 7	28	97147.8		

Overall Mean = 1200.1

Treatment Means:

	Reps	Periods	Days	Trts
1	1121.79	628.288	1236.03	1456.11
2	1278.42	1067.85	1164.18	944.096
3		3001.65		
4		1586.76		
5		603.863		
6		312.2		
L.S.D. 5%	184.307	319.229	184.307	184.307
L.S.D. 1%	248.627	430.634	248.627	248.627
L.S.D. .1%	330.559	572.545	330.559	330.559

Differences between means for Reps

	2
1	ns

Differences between means for Periods

	2	3	4	5	6
1	**	***	***	ns	ns
2		***	**	**	***
3			***	***	***
4				***	***
5					ns

Differences between means for Days

	2
1	ns

Differences between means for Trts

	2
1	***

APPENDIX 25.

STRATA PASTURE COMPOSITION (%)

P E R I O D	D A Y S	T R E A T M E N T	S T R A T A	REP. A.				REP. B.			
				%				%			
				L	S	OS	D	L	S	OS	D
I	1	L	T	18.52	80.00	1.08	0.38	9.25	84.47	1.55	4.72
			B	34.66	38.33	8.06	18.94	18.27	53.21	5.77	22.73
		H	T	22.01	75.04	2.36	0.57	4.42	93.25	1.10	1.21
			B	41.38	46.87	2.21	9.51	45.50	38.48	1.50	14.19
I	3	L	T	8.02	89.83	1.10	1.03	12.21	80.93	1.57	5.27
			B	22.26	53.43	6.19	18.09	25.34	49.27	0.08	25.83
		H	T	7.12	89.68	1.95	1.23	9.71	84.41	3.63	2.23
			B	28.22	53.45	1.47	16.84	35.46	32.65	10.20	21.86
II	1	L	T	5.17	90.08	0.66	4.08	13.43	69.96	0.62	15.97
			B	28.11	48.20	1.50	22.16	27.98	35.09	2.45	34.47
		H	T	6.21	87.01	3.75	3.00	13.54	76.73	5.98	3.73
			B	46.14	31.28	5.92	16.64	41.71	27.85	5.46	24.97
II	3	L	T	12.09	74.26	0.78	12.84	3.95	71.87	0.10	24.07
			B	14.91	44.52	0.78	39.78	19.48	41.97	1.35	37.19
		H	T	4.70	85.19	0.71	9.38	18.62	71.64	1.85	7.89
			B	23.82	32.85	6.56	36.75	21.54	43.68	1.23	33.53
III	1	L	T	7.33	13.16	4.19	75.30	6.51	21.17	0.00	72.30
			B	15.44	16.07	4.87	63.65	10.97	21.01	1.34	66.66
		H	T	2.50	46.01	0.89	50.57	1.55	10.36	0.00	88.07
			B	16.79	19.76	2.62	60.81	19.71	26.17	0.64	53.46
III	3	L	T	3.05	21.66	0.00	75.28	5.05	17.21	0.00	77.72
			B	10.96	28.95	4.40	55.66	11.12	36.78	0.00	52.09
		H	T	5.41	14.60	0.00	79.97	1.20	7.00	0.00	91.78
			B	13.71	20.33	1.11	64.83	8.65	11.29	1.95	78.08

APPENDIX 26.

STRATA PASTURE COMPOSITION (kg/ha)

P E R I O D S	D A Y S	T R E A T M E N T S	R E P . A.				R E P . B.			
			L	S	OS	D	L	S	OS	D
I	1	L T	420.0	1814.4	24.5	8.6	112.6	1028.0	18.9	57.4
		L B	1295.9	1433.2	301.4	708.2	775.9	2259.8	345.1	965.3
		H T	172.6	588.3	18.5	4.5	20.5	431.7	5.1	5.6
		H B	1571.6	1780.1	83.9	361.2	1375.0	1162.9	45.3	428.8
I	3	L T	157.0	1758.9	21.5	20.2	196.3	1301.3	25.2	84.7
		L B	733.7	1761.0	204.0	596.2	785.0	1526.4	2.5	800.2
		H T	87.0	1096.8	23.8	15.0	57.0	495.5	21.3	13.1
		H B	850.3	1610.4	44.3	507.4	729.8	671.9	209.9	449.9
II	1	L T	106.3	1852.9	13.6	83.9	204.3	1064.1	9.4	242.9
		L B	945.1	1620.5	50.4	745.0	1375.7	1725.3	120.5	1694.9
		H T	58.7	822.2	35.4	28.3	154.8	877.0	68.4	42.6
		H B	1124.4	762.3	144.3	405.5	1291.2	862.2	169.0	772.8
II	3	L T	286.4	1759.2	18.5	304.2	201.2	881.1	1.2	295.1
		L B	421.5	1258.6	22.1	1124.6	541.2	1165.9	37.5	1033.1
		H T	45.3	820.4	6.8	90.3	133.7	637.4	13.3	56.7
		H B	546.0	752.9	150.4	842.3	501.5	1016.9	28.6	780.6
III	1	L T	160.9	288.9	92.0	1652.8	148.2	481.8	0.0	1645.5
		L B	487.3	507.2	153.7	2008.8	379.7	727.2	46.4	2307.1
		H T	16.9	310.1	6.0	340.8	21.4	143.3	0.0	1218.0
		H B	379.1	446.2	59.2	1373.1	629.1	835.3	20.4	1706.4
	3	L T	45.7	324.9	0.0	1129.2	116.2	395.8	0.0	1787.6
		L B	369.1	975.0	148.2	1874.6	585.0	1935.0	0.0	2740.4
		H T	25.7	69.4	0.0	379.9	7.1	41.2	0.0	539.7
		H B	379.4	562.5	30.7	1793.8	167.9	219.1	37.8	1515.5

APPENDIX 27.

STRATA PASTURE COMPOSITION - % LEAF

Source	SS	DF	MS	F
Reps	.175182E-2	1	.175182E-2	.625161E-4 ns
Periods	1504.17	2	752.086	26.8393 ***
Days	293.288	1	293.288	10.4664 **
PeriodsxDays	31.0396	2	15.5198	.553845 ns
Trts	145.917	1	145.917	5.20726 *
PeriodsxTrts	78.9135	2	39.4568	1.40807 ns
DaysxTrts	50.3685	1	50.3685	1.79747 ns
Strata	2832.23	1	2832.23	101.072 ***
PeriodsxStrata	238.023	2	119.011	4.24709 *
DaysxStrata	229.469	1	229.469	8.18892 **
StrataxTrts	319.249	1	319.249	11.3929 **
Error 1	896.7	32	28.0219	

Overall Mean = 16.5994

Treatment Means:

	Reps	Periods	Days	Trts	Strata
1	16.6054	21.3969	19.0712	14.8558	8.91792
2	16.5933	19.6544	14.1275	18.3429	24.2808
3		8.74688			
L.S.D. 5%	3.11268	3.81223	3.11268	3.11268	3.11268
L.S.D. 1%	4.18473	5.12523	4.18473	4.18473	4.18473
L.S.D. .1%	5.5345	6.77835	5.5345	5.5345	5.5345

Differences between means for Reps

2	
1	ns

Differences between means for Periods

2	3
1	ns
2	***

Differences between means for Days

2	
1	**

Differences between means for Trts

2	
1	*

Differences between means for Strata

2	
1	***

APPENDIX 28.

STRATA PASTURE COMPOSITION - % STEM

Source	SS	DF	MS	F	
Reps	122.113	1	122.113	1.70597	ns
Periods	18698.8	2	9349.41	130.615	***
Days	12.628	1	12.628	.176418	ns
PeriodsxDays	56.189	2	28.0945	.392492	ns
Trts	30.5602	1	30.5602	.426939	ns
PeriodsxTrts	11.2622	2	5.63109	.785587E-1	ns
DaysxTrts	63.572	1	63.572	.888126	ns
Strata	8027.98	1	8027.98	112.154	***
PeriodsxStrata	5247.67	2	2623.84	36.6561	***
DaysxStrata	97.0714	1	97.0714	1.35613	ns
StrataxTrts	326.668	1	326.668	4.56368	*
Error 1	2290.56	32	71.5799		

Overall Mean = 48.4283

Treatment Means:

	Reps	Periods	Days	Trts	Strata
1	50.0233	65.2063	47.9154	49.2263	61.3608
2	46.8333	59.3581	48.9413	47.6304	35.4958
3		20.7206			
L.S.D. 5%	4.97486	6.09293	4.97486	4.97486	4.97486
L.S.D. 1%	6.68829	8.19144	6.68829	6.68829	6.68829
L.S.D. .1%	8.84556	10.8335	8.84556	8.84556	8.84556

Differences between means for Reps

	2
1	ns

Differences between means for Periods

	2	3
1	ns	***
2		***

Differences between means for Days

	2
1	ns

Differences for means for Trts

	2
1	ns

Differences between means for Strata

	2
1	***

APPENDIX 29

STRATA PASTURE COMPOSITION - % OTHER SPECIES

Source	S	DF	MS	F	
Reps	4.508	1	4.508	1.01046	ns
Periods	24.7911	2	12.3955	2.77843	ns
Days	6.446	1	6.446	1.44486	ns
PeriodsxDays	7.76558	2	3.88279	.87032	ns
Trts	4.52027	1	4.52027	1.01321	ns
PeriodsxTrts	33.0709	2	16.5354	3.70639	*
DaysxTrts	4.01942	1	4.01942	.900945	ns
Strata	40.0954	1	40.0954	8.9873	**
PeriodsxStrata	4.01068	2	2.00534	.449493	ns
DaysxStrata	.239419	1	.239419	.536653E-1	ns
StrataxTrts	.856002	1	.856002	.191871	ns
Error 1	142.763	32	4.46134		

Overall Mean = 2.32521

Treatment Means:

	Reps	Periods	Days	Trts	Strata
1	2.63167	3.11375	2.69167	2.01833	1.41125
2	2.01875	2.48625	1.95875	2.63208	3.23917
3		1.37563			
L.S.D. 5%	1.24199	1.52112	1.24199	1.24199	1.24199
L.S.D. 1%	1.66975	2.04502	1.66975	1.66975	1.66975
L.S.D. .1%	2.20832	2.70463	2.20832	2.20832	2.20832

Differences between means for Reps

2	
1	ns

Differences between means for Periods

2	3	
1	ns	*
2	ns	

Differences between means for Days

2	
1	ns

Differences between means for Trts

2	
1	ns

Differences between means for Strata

2	
1	**

STRATA PASTURE COMPOSITION - %DEAD MATTER

Source	S	DF	MS	F	
Reps	315.649	1	315.649	7.54143	**
Periods	31675.2	2	15837.6	378.389	***
Days	412.838	1	412.838	9.86344	**
PeriodsxDays	98.2306	2	49.1153	1.17345	ns
Trts	62.4492	1	62.4492	1.49203	ns
PeriodsxTrts	228.975	2	113.987	2.72337	ns
DaysxTrts	183.262	1	183.262	4.37846	*
Strata	678.68	1	678.68	16.2149	***
PeriodsxStrata	2936.3	2	1468.15	35.0767	***
DaysxStrata	.212005	1	.212005	.506518E-2	ns
Stratax Trts	.318505	1	.318505	.760966E-2	ns
Error 1	1339.37	32	41.8553		

Overall Mean = 33.2848

Treatment Means:

	Reps	Periods	Days	Trts	Strata
1	30.7204	10.2894	30.3521	34.4254	29.5246
2	35.8492	20.4256	36.2175	32.1442	37.045
3		69.1394			
L.S.D. 5%	3.80418	4.65914	3.80418	3.80418	3.80418
L.S.D. 1%	5.1144	6.26383	5.1144	5.1144	5.1144
L.S.D. .1%	6.76402	8.2842	6.76402	6.76402	6.76402

Differences between means for Reps

	2
1	**

Differences between means for Periods

	2	3
1	***	***
2		***

Differences between means for Days

	2
1	**

Differences between means for Trts

	2
1	ns

Differences between means for Strata

	2
1	***

STRATA PASTURE COMPOSITION - LEAF (kg/ha)

Source	SS	DF	MS	F
Reps	642.401	1	642.401	.252724E-1 ns
Periods	989791	2	494895	19.4694 ***
Days	576014	1	576014	22.6607 ***
PeriodsxDays	146889	2	73449.7	2.88955 ns
Trts	5296.21	1	5296.21	.208356 ns
PeriodsxTrts	34959.4	2	17479.7	.687662 ns
DaysxTrts	35806.7	1	35806.7	1.40865 ns
Strata	.486706E 7	1	.486706E 7	191.473 ***
PeriodsxStrata	534963	2	267482	10.5229 ***
DaysxStrata	476208	1	476208	18.7343 ***
TrtsxStrata	101255	1	101255	3.98344 ns
Error 1	813410	32	25419.1	

Overall Mean = 441.588

Treatment Means:

	Reps	Periods	Days	Trts	Strata
1	445.246	583.763	551.133	452.092	123.158
2	437.929	496.081	332.042	431.083	760.017
3		244.919			
L.S.D. 5%	93.7487	114.818	93.7487	93.7487	93.7487
L.S.D. 1%	126.037	154.364	126.037	126.037	126.037
L.S.D. .1%	166.69	204.153	166.69	166.69	166.69

Differences between means for Reps

2	
1	ns

Differences between means for Periods

2	3	
1	ns	***
2		***

Differences between means for Days

2	
1	***

Differences between means for Trts

2	
1	ns

Differences between means for Strata

2	
1	***

STRATA PASTURE COMPOSITION - STEM (kg/ha)

Source	SS	DF	MS	F
Reps	198893	1	198893	1.53117 ns
Periods	.53276E 7	2	.26638E 7	20.5072 ***
Days	12929.8	1	12929.8	.995396E-1 ns
PeriodsxDays	134829	2	67414.3	.518988 ns
Trts	.342978E 7	1	.342978E 7	26.4041 ***
PeriodsxTrts	153059	2	76529.4	.58916 ns
DaysxTrts	33464.6	1	33464.6	.257627 ns
Strata	.1433E 7	1	1433E 7	11.0319 **
PeriodsxStrata	508733	2	254367	1.95824 ns
DaysxStrata	6197.11	1	6197.11	.477084E-1 ns
TrtsxStrata	3434.09	1	3434.09	.264373E-1 ns
Error 1	.415666E 7	32	129896	

Overall Mean = 976.292

Treatment Means:

	Reps	Periods	Days	Trts	Strata
1	1040.66	1295.01	992.704	1243.6	803.508
2	911.921	1117.43	959.879	708.983	1149.08
3		516.431			
L.S.D. 5%	211.925	259.554	211.925	211.925	211.925
L.S.D. 1%	284.916	348.949	284.916	284.916	284.916
L.S.D. .1%	376.814	461.501	376.814	376.814	376.814

Differences between means for Reps

	2
1	ns

Differences between means for Periods

	2	3
1	ns	***
2		***

Differences between means for Days

	2
1	ns

Differences between means for Trts

	2
1	***

Differences between means for Strata

	2
1	**

STRATA PASTURE COMPOSITION - OTHER SPECIES (kg/ha)

Source	SS	DF	MS	F
Reps	5794.81	1	5794.81	1.88354 ns
Periods	15475.4	2	7737.7	2.51506 ns
Days	9741.3	1	9741.3	3.1663 ns
PeriodsxDays	1053.69	2	526.844	.171245 ns
Trts	2326.87	1	2326.87	.756323 ns
PeriodsxTrts	19700.7	2	9850.33	3.20174 ns
DaysxTrts	5346.74	1	5346.74	1.7379 ns
Strata	77779.1	1	77779.1	25.2813 ***
PeriodsxStrata	11207.3	2	5603.66	1.82141 ns
DaysxStrata	2751.24	1	2751.24	.894261 ns
TrtsxStrata	1654.4	1	1654.4	.537745 ns
Error 1	98449.7	32	3076.55	

Overall Mean = 57.8958

Treatment Means:

	Reps	Periods	Days	Trts	Strata
1	68.8833	80.95	72.1417	64.8583	17.6417
2	46.9083	55.5875	43.65	50.9333	98.15
3		37.15			
L.S.D. 5%	32.615	39.9451	32.615	32.615	32.615
L.S.D. 1%	43.8482	53.7028	43.8482	43.8482	43.8482
L.S.D. .1%	57.9912	71.0244	57.9912	57.9912	57.9912

Differences between means for Reps

2	
1	ns

Differences between means for Periods

2	3
1	ns
2	*
	ns

Differences between means for Days

2	
1	ns

Differences between means for Trts

2	
1	ns

Differences between means for Strata

2	
1	***

STRATA PASTURE COMPOSITION - DEAD MATTER (kg/ha)

Reps	477105	1	477105	8.99376	**
Periods	.127542E 8	2	.63771E 7	120.213	***
Days	23.6605	1	23.6605	.446017E-3	ns
PeriodsxDays	31588	2	15794	.297728	ns
Trts	.218398E 7	1	.218398E 7	41.1695	***
PeriodsxTrts	804412	2	402206	7.58187	**
DaysxTrts	8187.57	1	818.57	.154342	ns
Strata	.637226E 7	1	.637226E 7	120.122	***
PeriodsxStrata	144214	2	72107.2	1.35927	ns
DaysxStrata	29835.2	1	29835.2	.562415	ns
TrtsxStrata	24457.8	1	24457.8	.461046	ns
Error 1	.169755E 7	32	53048.4		

Overall Mean = 782.965

Treatment Means:

	Reps	Periods	Days	Trts	Strata
1	683.267	314.144	783.667	996.271	418.608
2	882.663	533.925	782.263	569.658	1147.32
3		1500.83			
L.S.D. 5%	135.432	165.87	135.432	135.432	135.432
L.S.D. 1%	182.077	222.998	182.077	182.077	182.077
L.S.D. .1%	240.805	294.925	240.805	240.805	240.805

Differences between means for Reps

	2
1	**

Differences between means for Periods

	2	3
1	*	***
2		***

Differences between means for Days

	2
1	ns

Differences between means for Trts

	2
1	***

Differences between means for Strata

	2
1	***

APPENDIX 35.

ANIMAL EXTRUSA COMPOSITION

P E R I O D	D A Y S	T R E A T M E N T	REP. A.				REP. B.				
			%				%				
			L	S	OS	D	L	S	OS	D	
I	1	L	88.30	8.61	2.72	0.35	93.76	5.05	0.33	0.84	
		H	95.26	2.79	1.32	0.61	92.23	6.16	0.85	0.74	
	3	L	92.67	2.79	0.63	3.89	71.12	24.80	0.00	3.97	
		H	87.50	6.85	0.60	5.04	88.65	4.36	0.46	6.51	
	II	1	L	90.50	6.21	0.76	2.51	95.76	2.24	0.32	1.65
			H	91.94	4.69	1.06	2.29	89.41	7.84	1.54	1.20
3		L	87.71	4.31	2.83	5.12	88.56	4.57	0.00	6.86	
		H	91.73	5.52	0.05	2.68	85.94	9.07	0.24	4.72	
III		1	L	86.50	3.23	0.03	10.22	85.72	4.58	0.00	9.68
			H	90.16	1.48	0.06	8.28	93.65	2.35	0.26	3.72
	3	L	80.24	5.92	0.00	13.83	75.04	6.82	0.00	18.13	
		H	85.89	2.25	0.00	11.84	83.91	2.59	0.00	13.49	
	IV	1	L	80.24	3.09	1.11	15.53	84.75	4.00	0.29	10.94
			H	84.67	1.74	0.00	13.58	87.43	2.67	0.19	9.69
3		L	81.89	2.43	0.20	15.45	78.68	1.44	0.00	19.86	
		H	76.21	2.12	0.00	21.66	72.92	1.55	0.00	25.51	
V		1	L	93.90	0.59	0.00	5.50	93.82	0.88	0.00	5.28
			H	96.96	0.80	0.00	2.23	95.88	0.51	0.03	3.57
	3	L	96.35	0.37	0.00	3.26	85.83	1.10	0.00	13.05	
		H	95.99	0.64	0.00	3.34	94.57	1.58	0.00	3.84	
	VI	1	L	96.79	0.81	0.00	2.39	96.08	0.70	0.00	3.20
			H	95.11	0.00	0.00	4.88	97.52	0.24	0.13	2.09
3		L	95.47	0.22	0.00	4.29	94.30	0.12	0.00	5.56	
		H	94.12	1.12	0.00	4.75	96.38	0.24	0.00	3.37	

ANIMAL EXTRUSA COMPOSITION - LEAF

Source	SS	DF	MS	F
Reps	22.715	1	22.715	1.47908 ns
Periods	1248.8	5	249.759	16.2629 ***
Days	268.38	1	268.38	17.4754 ***
PeriodsxDays	87.0337	5	17.4067	1.13343 ns
Trts	54.6559	1	54.6559	3.55889 ns
PeriodsxTrts	100.936	5	20.1872	1.31447 ns
DaysxTrts	.190008	1	.190008	.123722E-1 ns
Error 1	430.013	28	15.3576	

Overall Mean = 89.1496

Treatment Means:

	Reps	Periods	Days	Trts
1	89.8375	88.6863	91.5142	88.0825
2	88.4617	90.1938	86.785	90.2167
3		85.1388		
4		80.8488		
5		94.3088		
6		95.7213		
L.S.D. 5%	2.31732	4.01372	2.31732	2.31732
L.S.D. 1%	3.12603	5.41444	3.12603	3.12603
L.S.D. .1%	4.15618	7.19871	4.15618	4.15618

Differences between means for Reps

2	
1	ns

Differences between means for Periods

	2	3	4	5	6
1	ns	ns	***	**	**
2		*	***	*	**
3			*	***	***
4				***	***
5					ns

Differences between means for Days

2	
1	***

Differences between means for Trts

2	
1	ns

APPENDIX 37

ANIMAL EXTRUSA COMPOSITION - STEM

Source	SS	DF	MS	F	
Reps	15.0752	1	15.0752	1.47944	ns
Periods	316.425	5	63.2849	6.21061	***
Days	9.66608	1	9.66608	.948603	ns
PeriodsxDays	30.3525	5	6.07051	.595744	ns
Trts	13.7602	1	13.7602	1.35039	ns
PeriodsxTrts	72.5518	5	14.5104	1.42401	ns
DaysxTrts	1.42141	1	1.42141	.139493	ns
Error 1	285.314	28	10.1898		

Overall Mean = 3.41792

Treatment Means:

	Reps	Periods	Days	Trts
1	2.8575	7.67625	2.96917	3.95333
2	3.97833	5.55625	3.86667	2.8825
3		3.6525		
4		2.38		
5		.81125		
6		.43125		
L.S.D. 5%	1.88759	3.2694	1.88759	1.88759
L.S.D. 1%	2.54633	4.41037	2.54633	2.54633
L.S.D. .1%	3.38544	5.86376	3.38544	3.38544

Differences between means for Reps

2	
1	ns

Differences between means for Periods

	2	3	4	5	6
1	ns	*	**	***	***
2		ns	ns	**	**
3			ns	ns	ns
4				ns	ns
5					ns

Differences between means for Days

2	
1	ns

Differences between means for Trts

2	
1	ns

APPENDIX 38

ANIMAL EXTRUSA COMPOSITION - OTHER SPECIES

Source	SS	DF	MS	F
Reps	.943602	1	.943602	2.87667 ns
Periods	6.82656	5	1.36531	4.16229 **
Days	.747502	1	.747502	2.27884 ns
PeriodsxDays	1.10836	5	.221672	.67579 ns
Trts	.123019	1	.123019	.375035 ns
PeriodsxTrts	.293594	5	.587188E-1	.17901 ns
DaysxTrts	.999187E-1	1	.999187E-1	.304612 ns
Error 1	9.18454	28	.328019	

Overall Mean = .333542

Treatment Means:

	Reps	Periods	Days	Trts
1	.47375	.86375	.458333	.384167
2	.193333	.85	.20875	.282917
3		.04375		
4		.22375		
5		375003E-2		
6		.01625		
L.S.D. 5%	.338668	.586591	.338668	.338668
L.S.D. 1%	.456858	.791302	.456858	.456858
L.S.D. .1%	.607411	1.05207	.607411	.607411

Difference between means for Reps

2	
1	ns

Differences between means for Periods

	2	3	4	5	6
1	ns	**	*	**	**
2		**	*	**	**
3			ns	ns	ns
4				ns	ns
5					ns

Differences between means for Days

2	
1	ns

Differences between means for Trts

2	
1	ns

ANIMAL EXTRUSA COMPOSITION - DEAD MATTER

Source	SS	DF	MS	F	
Reps	4.07751	1	4.07751	.777729	ns
Periods	1225.84	5	245.168	46.7625	***
Days	204.559	1	204.559	39.0168	***
PeriodsxDays	72.4811	5	14.4962	2.76496	*
Trts	9.80117	1	9.80117	1.86944	ns
PeriodsxTrts	56.0225	5	11.2045	2.1371	ns
DaysxTrts	1.58777	1	1.58777	.302846	ns
Error 1	146.799	28	5.24284		

Overall Mean = 7.10479

Total Means:

	Reps	Periods	Days	Trts
1	6.81333	2.74375	5.04042	7.55667
2	7.39625	3.37875	9.16917	6.65292
3		11.1488		
4		16.5275		
5		5.01375		
6		3.81625		
L.S.D. 5%	1.35397	2.34514	1.35397	1.35397
L.S.D. 1%	1.82648	3.16355	1.82648	1.82648
L.S.D. .1%	2.42838	4.20607	2.42838	2.42838

Differences between means for Reps

2	
1	ns

Differences between means for Periods

	2	3	4	5	6
1	ns	***	***	ns	ns
2		***	***	ns	ns
3			***	***	***
4				***	***
5					ns

Differences between means for Days

2	
1	***

Differences between means for Trts

2	
1	ns

COMPOSITION COMPARISONANIMAL (A) EXTRUSA COMPOSITION (%) V PASTURE (P) COMPOSITION(%)

Source	SS	DF	MS	F	
Comp.	160656	3	53552	2282.06	***
PvAxComp	145886	3	48628.5	2072.25	***
CompXPeriods	59829.3	15	3988.62	169.971	***
PvAxCompXPeriods	33892.1	15	2259.47	96.2849	***
CompXDays	2696.5	3	898.933	38.3027	***
PvAxCompXDays	446.51	3	148.837	6.3425	***
CompXPeriodsXDays	375.215	15	25.0143	1.06596	ns
CompXTrts	45.8011	3	15.267	.650588	ns
PvAxCompXTrts	76.4028	3	25.4676	1.08527	ns
CompXPeriodsXTrts	497.652	15	33.1768	1.41379	ns
CompXDaysXTrts	155.713	3	51.9043	2.21184	ns
Error 1	6077.83	259	23.4665		

Overall Mean = 25.0002

Composition Means:

1	57.1916
2	17.6182
3	24.3207
4	.870106
5	
6	

L.S.D. 5%	1.37685
L.S.D. 1%	1.8144
L.S.D. .1%	2.32727

All differences between means significant at *** level.

P E R I O D	T R E A T M E N T	% ORGANIC MATTER DIGESTIBILITY (OMD)			
		REP. A.		REP. B.	
		Days		Days	
		1	3	1	3
I	L	62.99	58.16	55.42	54.88
	H	66.22	60.36	62.89	64.92
II	L	55.96	55.39	56.67	60.85
	H	59.32	59.88	59.98	59.46
III	L	50.76	53.72	54.95	57.20
	H	59.79	52.65	54.45	53.82
IV	L	53.76	55.92	59.55	56.23
	H	58.78	56.39	60.48	52.60
V	L	58.97	61.29	67.11	62.48
	H	71.76	63.34	70.60	56.14
VI	L	74.51	70.55	73.02	66.07
	H	78.37	66.82	80.04	67.64

Source	SS	DF	MS	F
Reps	.066755	1	.066755	.805919E-2 ns
Days	131.97	1	131.97	15.9325 ***
Periods	1581.02	5	316.204	38.1747 ***
DaysxPeriods	128.644	5	25.7289	3.1062 *
Trts	75.7268	1	75.7268	9.14234 **
DaysxTrts	69.4324	1	69.4324	8.38243 **
PeriodsxTrts	32.5139	5	6.50279	.785068 ns
Error 1	231.926	28	8.28309	

Overall Mean = 61.1065

Treatment Means

	Reps	Days	Periods	Trts
1	61.0692	62.7646	60.73	59.8504
2	61.1438	59.4483	58.4388	62.3625
3			54.6675	
4			56.7138	
5			63.9613	
6			72.1275	
L.S.D. 5%	1.70185	1.70185	2.94769	1.70185
L.S.D. 1%	2.29577	2.29577	3.97638	2.29577
L.S.D. .1%	3.05231	3.05231	5.28676	3.05231

Differences between means for Reps

2	
1	ns

Differences between means for Days

2	
1	***

Differences between means for Periods

	2	3	4	5	6
1	ns	***	**	*	***
2		*	ns	***	***
3			ns	***	***
4				***	***
5					***

Differences between means for Trts

2	
1	**

APPENDIX 43.

STRATA PASTURE DIGESTIBILITY

P E R I O D	T R E A T M E N T	S T R A T A	% Organic Matter Digestibility (OMD)			
			REP.A.		REP.B.	
			Days		Days	
			1	3	1	3
I	L	T	63.52	55.69	47.85	57.74
		B	62.68	59.64	57.59	53.41
	H	T	62.76	56.52	52.87	54.09
		B	66.94	61.92	64.43	68.01
II	L	T	51.24	50.44	49.24	57.16
		B	58.86	59.55	58.98	62.49
	H	T	49.93	57.00	51.62	54.69
		B	62.97	61.10	63.12	60.94
III	L	T	47.76	47.32	52.70	47.69
		B	52.85	56.58	56.43	61.36
	H	T	48.51	44.48	46.12	43.51
		B	63.16	54.06	58.07	56.95

Source	S	DF	MS	F
Rep	7.06871	1	7.0681	.566801 ns
Days	1.28707	11	1.28707	.103203 ns
Periods	378.334	2	189.167	15.1682 ***
DaysxPeriods	37.7414	2	18.8707	1.51314 ns
Trts	25.5208	1	25.5208	2.04637 ns
DaysxTrts	14.7408	1	14.7408	1.18198 ns
PeriodsxTrts	43.6463	2	21.8231	1.74988 ns
Strata	765.123	1	765.123	61.3509 ***
DaysxStrata	3.14163	1	3.14163	.25191 ns
PeriodsxStrata	45.3679	2	22.6839	1.8189 ns
TrtsxStrata	47.0052	1	47.0052	3.76909 ns
Error 1	399.08	32	12.4712	

Overall Means = 56.0946

Treatment Means:

	Reps	Days	Periods	Trts	Strata
1	56.4783	56.2583	59.1038	55.3654	52.1021
2	55.7108	55.9308	56.8331	56.8238	60.0871
3			52.3469		
L.S.D. 5%	2.07654	2.07654	2.54323	2.07654	2.07654
L.S.D. 1%	2.79174	2.79174	3.41916	2.79174	2.79174
L.S.D. .1%	3.6922	3.6922	4.522	3.6922	3.6922

Differences between means for Reps

2	
1	ns

Differences between means for Days

2	
1	ns

Differences between means for Periods

2		3	
1	ns	***	
2		**	

Differences between means for Trts

2	
1	ns

Differences between means for Strata

2	
1	***

APPENDIX 45.

ANIMAL EXTRUSA DIGESTIBILITY

P E R I O D	T R E A T M E N T	% ORGANIC MATTER DIGESTIBILITY (OMD)			
		REP. A.		REP. B.	
		Days		Days	
		1	3	1	3
I	L	74.81	70.84	75.64	66.63
	H	73.39	70.46	75.34	72.71
II	L	76.54	69.56	77.06	72.49
	H	76.01	70.53	78.64	70.53
III	L	70.46	65.51	69.48	65.66
	H	69.93	64.98	71.21	63.11
IV	L	72.64	69.63	73.99	67.31
	H	77.21	67.08	81.42	65.81
V	L	79.69	77.59	79.09	67.46
	H	79.84	78.41	79.39	78.19
VI	L	86.14	80.21	81.19	78.49
	H	82.84	80.59	83.74	79.99

Source	SS	DF	MS	F	
Reps	2.21883	1	2.21883	.389042	ns
Days	362.56	1	362.56	63.5701	***
Periods	950.435	5	190.087	33.3292	***
DaysxPeriods	36.0443	5	7.20886	1.26398	ns
Trts	11.252	1	11.252	1.97289	ns
DaysxTrts	.310086E-1	1	.310086E-1	.543694E-2	ns
PeriodsxTrts	17.2302	5	3.44604	.604217	ns
Error 1	159.693	28	5.70332		

Overall Mean = 74.1554

Treatment Means:

	Reps	Days	Periods	Trts
1	74.3704	76.9038	72.4775	73.6713
2	73.9404	71.4071	73.92	74.6396
3			67.5425	
4			71.8863	
5			77.4575	
6			81.6488	
L.S.D. 5%	1.41218	1.41218	2.44596	1.41218
L.S.D. 1%	1.905	1.905	3.29956	1.905
L.S.D. .1%	2.53277	2.53277	4.38689	2.53277

Differences between means for Reps

2	
1	ns

Differences between means for Days

2	
1	***

Differences between means for Periods

	2	3	4	5	6
1	ns	***	ns	***	***
2		***	ns	**	***
3			**	***	***
4				***	***
5					**

Differences between means for Trts

2	
1	ns

PASTURE(P) V'S ANIMAL (A) DIGESTIBILITY

Source	SS	DF	MS	F
P V A	4086.61	1	4086.61	490.69 ***
Reps	.757931	1	.757931	.910068E-1 ns
Days	466.005	1	466.005	55.9545 ***
P V AxDays	28.5253	1	28.5253	3.42511 ns
Periods	2432.28	5	486.456	58.41 ***
P V AxPeriods	99.1774	5	19.8355	2.3817 *
DaysxPeriods	46.3221	5	9.26442	1.1124 ns
Trts	72.6798	1	72.6798	8.72686 **
P V AxTrts	14.299	1	14.299	1.71692 ns
DaysxTrts	36.199	1	36.199	4.34651 *
PeriodsxTrts	28.1981	5	5.63961	.677163 ns
Error 1	566.324	68	8.3283	

Overall Mean = 67.6309

Treatment Means:

	P V A	Reps	Days	Periods	Trts
1	61.1065	67.7198	69.8342	66.6038	66.7608
2	74.1554	67.5421	65.4277	66.1794	68.5011
3				61.105	
4				64.3	
5				70.7094	
6				76.8881	
L.S.D. 5%	1.17548	1.17548	1.17548	2.036	1.17548
L.S.D. 1%	1.5611	1.5611	1.5611	2.70391	1.5611
L.S.D. .1%	2.02608	2.02608	2.02608	3.50927	2.02608

Differences between means for P V A

2	
1	***

Differences between means for Reps

2	
1	ns

Differences between means for Days

2	
1	***

Differences between means for Periods

	2	3	4	5	6
1	ns	***	*	***	***
2		***	ns	***	***
3			**	***	***
4				***	***
5					***

Differences between means for Trts

2	
1	**

P E R I O D	T R E A T M E N T	Rep.	LOpe	ASte	CYcr	ANod	POssp.	HOla	DAgl	BRmo	FEru	Trspg	Weeds	Dead	
														Matter	
I	1 L A	kg/ha	1679.8	984.5	598.5	347.5	574.4	178.1					172.0		
		%	27.96	16.38	9.96	5.78	9.56	2.96					2.86	2.35	11.59
	B	kg/ha	2477.6	764.7	105.9	205.6	732.8	73.9	3.8				92.6		
		%	45.34	13.99	2.36	3.76	14.32	1.35	0.07				1.69	0.04	17.49
	H A		1322.3	1181.4	256.5	330.2	262.4	440.9	0.5				148.9		
		%	28.85	25.78	5.59	7.20	5.72	9.62	0.01				3.24	1.91	11.98
	B		1176.2	212.9	389.2	403.4	264.9	224.0	0.3		2.4		167.1		
		%	33.74	6.10	11.17	11.57	7.46	6.42	0.01		0.07		4.27	6.70	12.34
	3	L A		1721.9	290.9	1119.2	506.5	337.7	384.5		21.0		231.9		
			%	32.77	5.53	21.30	9.64	6.42	7.31		0.40		4.41	0.12	12.02
		B		2221.9	527.5	185.8	65.4	542.2	57.2		9.9		72.0		
			%	54.51	12.94	4.55	1.60	13.30	1.40		0.21		1.76		25.11
H A			1445.5	710.4	620.0	314.8	269.6	246.0				42.2			
		%	34.12	16.77	14.63	7.43	6.36	5.80				0.99	0.73	13.09	
B		707.8	406.5	452.4	209.2	175.2	137.2				130.2				
	%	26.75	15.36	17.10	7.90	6.62	4.67				4.92	1.97	14.10		
II	1 L A		781.9	851.9	1367.9	511.8	56.1	823.4				279.2			
		%	14.42	15.71	25.24	9.44	1.03	15.19				5.16	2.03	11.68	
	B		859.5	960.9	338.3	346.5	674.1	678.6				194.6			
		%	13.35	14.92	5.25	5.38	10.46	10.54				3.02	1.67	35.35	
	H A		628.2	242.9	976.0	198.3	22.9	364.9				177.2			
		%	18.57	7.18	28.85	5.86	0.67	10.78				5.24	8.42	14.32	

contd.

contd.

	B	1197.8	406.6	483.9	296.7	11.7	633.0		159.7		
	%	28.56	9.69	11.53	7.07	0.27	15.09		3.80	2.25	21.63
		4									
3	L A	1144.0	480.6	1374.0	556.5	18.7	376.2		44.7		
	%	22.01	9.24	26.44	10.71	0.35	7.24		0.85		23.07
	B	1471.2	437.8	195.7	64.6	274.8	90.4	2.8	63.3		
	%	36.74	10.93	4.88	1.61	6.86	2.25	0.07	1.58		34.99
	H A	538.6	602.0	635.5	174.8	22.9	256.5		60.1		
	%	16.54	18.49	19.52	5.36	0.70	7.88		1.84		29.58
	B	386.5	387.6	606.2	347.3	95.5	193.4		23.0		
	%	12.68	12.72	19.90	10.78	3.13	6.34		0.75	0.73	32.26
<hr/>											
III	1 L A	929.3	925.8	646.6	103.4	22.7	340.9	5.9	85.8		
	%	17.36	17.30	12.08	1.93	0.42	6.37	0.11	1.60	1.78	40.96
	B	969.5	815.4	227.6	28.3	157.3	295.0	5.2	119.4		
	%	16.89	14.21	3.96	0.49	2.74	5.14	0.09	2.08		54.33
	H A	321.4	240.6	198.7	97.2	106.4	108.2		75.2		
	%	10.96	8.20	6.77	3.31	3.62	3.69		2.56	0.79	60.00
	B	564.2	775.9	351.5	255.3	10.2	161.0	17.4	32.9	12.0	
	%	12.33	16.96	7.68	5.57	0.22	3.51	0.38	0.72	0.26	0.30
											50.71
3	L A	406.9	686.3	151.9	160.9	30.6	459.2		18.5		
	%	8.35	14.09	3.11	3.30	0.62	9.43		0.38	1.85	58.75
	B	774.3	639.7	163.0	109.4	1078.3	244.6	0.5	234.1		
	%	10.24	8.45	2.15	1.44	14.26	3.23	0.02	3.09		57.04
	H A	297.0	205.4	46.0	146.8	131.6	218.4		19.9		
	%	9.16	6.33	1.41	4.52	4.05	6.73		0.61	0.14	66.96
	B	128.5	492.0	394.7	32.0	110.4	29.5		0.6		
	%	5.08	19.45	15.61	1.26	4.36	1.16		0.02		52.99

contd.

contd.

IV	1	L	A	129.0	268.7	4.2	73.5	33.8	10.1	0.8	4.7	81.06	
			%	4.62	9.62	0.15	2.63	1.21	0.36	0.03	0.17		0.14
	B		350.3	163.6	5.7	4.4	9.4	20.2				74.79	
		%	15.95	7.45	0.26	0.20	0.43	0.92					
	H	A		228.0	166.0	4.9	34.7	12.8			3.2	76.06	
			%	12.14	8.84	0.26	1.85	0.68			0.17		
	B		547.8	121.7	5.0	2.7	0.9			28.9		68.68	
		%	24.27	5.39	0.22	0.12	0.04			1.28			
	3	L	A		32.6	174.6	0.6	46.3	7.9	51.4		3.5	84.70
				%	1.57	8.42	0.03	2.23	0.38	2.48		0.17	
		B		123.3	280.2		76.5	53.9	6.7				72.73
			%	6.22	14.13		3.86	2.72	0.34				
H		A		94.4	82.6		1.3	7.8	0.5		15.4	88.71	
			%	5.20	4.55		0.07	0.43	0.03		0.85		
B		58.8	81.6		1.6	9.8	4.3	1.7		11.8	89.53		
	%	3.79	5.26		0.10	0.63	0.28	0.11		0.76			

V	1	L	A	1302.7	120.2			77.9	47.4		6.5	28.16	
			%	60.17	5.55			3.60	2.19		0.30		
	B		984.6	173.3	106.5	7.9	28.5	125.5			16.9	34.10	
		%	44.94	7.91	4.86	0.36	1.30	5.73			0.77		
	H	A		1019.3	374.3	35.1	25.7	47.4	44.2		8.8	22.53	
			%	50.76	18.64	1.75	1.28	2.36	2.20		0.44		
	B		922.5	162.0	9.2	13.2	24.5	12.15	32.8		26.5	17.84	
		%	62.97	11.06	0.63	0.90	1.67	0.83	2.24		1.81		
	3	L	A		380.0	217.5			7.3	1.3	3.5		45.00
				%	35.51	20.33			0.68	0.12	0.33		
		B		501.0	16.6	7.8		41.5	22.3	46.6		7.0	50.30
			%	38.72	1.28	0.60		3.21	1.72	3.60		0.54	
H		A		295.4	60.3		12.4	9.7	31.8	18.5		2.6	47.58
			%	35.85	7.32		1.50	1.18	3.86	2.25		0.32	
B		257.2	33.7		2.3	3.0	4.8	1.8		0.8	56.11		
	%	36.74	4.81		0.33	0.43	0.69	0.25		0.11		0.48	

contd.

contd.

VI	1	L	A	687.7	239.0	11.3	52.0	104.7		26.8		
			%	42.58	14.80	0.70	3.22	6.48		1.66		26.56
			B	637.8	256.8	1.1	0.8	86.9		4.1		
			%	40.37	16.25	0.07	0.05	5.50		0.26		37.47
		H	A	670.8	140.8	16.2	42.8	82.9	41.4	3.6		
			%	49.69	10.43	1.20	3.17	6.14	3.07	0.27	2.80	23.19
			B	805.1	199.6	28.1	69.2	58.7	31.2	31.2		
			%	54.18	13.43	1.89	4.66	3.95	2.10	2.10	1.91	15.73
	3	L	A	234.6	102.9	13.4	19.1	32.4	14.7			
			%	26.60	11.67	1.52	2.16	3.67	1.67			52.69
			B	341.7	63.3		2.6	33.1				
			%	44.55	8.25		0.34	4.31				42.54
		H	A	129.0	48.4	2.7	2.6	13.2	3.0	1.5		
			%	30.50	11.44	0.63	0.61	3.12	0.70	0.35		52.60
			B	146.4	38.0	1.2	18.2	18.9		16.9		
			%	28.37	7.36	0.24	3.52	3.67		3.28		53.53

APPENDIX 49

PASTURE SPECIES COMPOSITION - % LOLIUM PERENNE

Source	SS	DF	MS	F
Periods	9504.15	5	1900.83	46.4832 ***
Days	590.803	1	590.803	14.4476 ***
Periods x Days	779.306	5	155.861	3.81145 **
Trts	18.6751	1	18.6751	.456683 ns
Periods x Trts	247.506	5	49.5013	1.21051 ns
Days x Trts	280.72	1	280.72	6.86477 *
Reps	212.605	1	212.605	5.19907 *
Error 1	1145	28	40.8929	

Overall Mean = 26.9488

Treatment Means:

	Periods	Days	Trts	Reps
1	35.505	30.4571	27.5725	24.8442
2	20.3588	23.4404	26.325	29.0533
3	11.2963			
4	9.22			
5	45.7075			
6	39.605			
L.S.D. 5%	6.54952	3.78136	3.78136	3.78136
L.S.D. 1%	8.83519	5.101	5.101	5.101
L.S.D. .1%	11.7467	6.78198	6.78198	6.78198

Differences between means for Periods

	2	3	4	5	6
1	***	***	***	**	ns
2		**	**	***	***
3			ns	***	***
4				***	***
5					ns

Differences between means for Days

	2
1	***

Differences between means for Trts

	2
1	ns

Differences between means for Reps

	2
1	*

APPENDIX 50

PASTURE SPECIES COMPOSITION - % AGROSTIS TENUIS

Source	SS	DF	MS	F
Periods	210.553	5	42.1106	1.42379 ns
Days	34.4594	1	34.4594	1.16509 ns
Periods x Days	37.1001	5	7.42002	.250876 ns
Trts	1.26426	1	1.26426	.427453E-1 ns
Periods x Trts	74.322	5	14.8644	.502575 ns
Days x Trts	6.01376	1	6.01376	.203329 ns
Reps	24.5245	1	24.5245	.82919 ns
Error 1	828.141	28	29.5765	

Overall Mean = 11.4773

Treatment Means:

	Periods	Days	Trts	Reps
1	14.1063	12.3246	11.6396	12.1921
2	12.36	10.63	11.315	10.7625
3	13.1238			
4	7.9575			
5	9.6125			
6	11.7038			
L.S.D. 5%	5.57004	3.21587	3.21587	3.21587
L.S.D. 1%	7.5139	4.33815	4.33815	4.33815
L.S.D. .1%	9.99002	5.76774	5.76774	5.76774

Differences between means for Periods

	2	3	4	5	6
1	ns	ns	*	ns	ns
2		ns	ns	ns	ns
3			ns	ns	ns
4				ns	ns
5					ns

Differences between means for Days

	2
1	ns

Differences between means for Trts

	2
1	ns

Differences between means for Reps

	2
1	ns

PASTURE SPECIES COMPOSITION - % CYNOSURUS CRISTATUS

Source	SS	DF	MS	F
Periods	1980.22	5	396.045	13.0584 ***
Days	2.60868	1	2.60868	.860129E-1 ns
Periods x Days	113.224	5	22.6448	.746642 ns
Trts	28.6907	1	28.6907	.945986 ns
Periods x Trts	39.5404	5	7.90808	.260744 ns
Days x Trts	2.90575	1	2.90575	.958082E-1 ns
Reps	91.3836	1	91.3836	3.01309 ns
Error 1	849.208	28	30.3289	

Overall Mean = 6.16771

Treatment Means:

	Periods	Days	Trts	Reps
1	10.8325	5.93458	5.39458	7.5475
2	17.7013	6.40083	6.94083	4.78792
3	6.59625			
4	.115			
5	.98			
6	.78125			
L.S.D. 5%	5.64045	3.25651	3.25651	3.25651
L.S.D. 1%	7.60887	4.39299	4.39299	4.39299
L.S.D. .1%	10.1163	5.84064	5.84064	5.84064

Differences between means for Periods

	2	3	4	5	6
1	*	ns	***	**	**
2		***	***	***	***
3			*	ns	*
4				ns	ns
5					ns

Differences between means for Days

	2
1	ns

Differences between means for Trts

	2
1	ns

Differences between means for Reps

	2
1	ns

PASTURE SPECIES COMPOSITION - % ANTHOXANTHUM ODOCRATUM

Source	SS	DF	MS	F
Periods	313.34	5	62.6681	12.3895 ***
Days	.637103	1	.637103	.125955 ns
Periods x Days	2.70749	5	.541497	.107054 ns
Trts	13.8783	1	13.8783	2.74373 ns
Periods x Trts	27.9973	5	5.59946	1.10701 ns
Days x Trts	3.42935	1	3.42935	.677983 ns
Reps	8.6106	1	8.6106	1.70232 ns
Error 1	141.629	28	5.05817	

Overall Mean = 3.45979

Treatment Means:

	Periods	Days	Trts	Reps
1	6.86	3.575	2.92208	3.88333
2	7.02625	3.34458	3.9975	3.03625
3	2.7275			
4	1.3825			
5	.54625			
6	2.21625			
L.S.D. 5%	2.30347	1.32991	1.32991	1.32991
L.S.D. 1%	3.10734	1.79402	1.79402	1.79402
L.S.D. .1%	4.13133	2.38523	2.38523	2.38523

Differences between means for Periods

	2	3	4	5	6
1	ns	***	***	***	***
2		***	***	***	***
3			ns	ns	ns
4				ns	ns
5					ns

Differences between means for Days

	2
1	ns

Differences between means for Trts

	2
1	ns

Differences between means for Reps

	2
1	ns

APPENDIX 53

PASTURE SPECIES COMPOSITION - % POA SPR

Source	SS	DF	MS	F
Periods	272.389	5	54.4779	6.7471 ***
Days	2.60401	1	2.60401	.322507 ns
Periods x Days	25.5492	5	5.10984	.632856 ns
Trts	42.6387	1	42.6387	5.28082 *
Periods x Trts	38.7223	5	7.74446	.979153 ns
Days x Trts	12.3019	1	12.3019	1.52359 ns
Reps	41.7014	1	41.7014	5.16473 *
Error 1	226.079	28	8.07426	

Overall Mean = 3.82583

Treatment Means:

	Periods	Days	Trts	Reps
1	8.6425	4.05875	2.88333	4.75792
2	3.37	3.59292	4.76833	2.89375
3	3.6325			
4	1.28125			
5	1.82875			
6	4.2			
L.S.D. 5%	2.91029	1.68026	1.68026	1.68026
L.S.D. 1%	3.92594	2.26664	2.26664	2.26664
L.S.D. .1%	5.21969	3.01359	3.01359	3.01359

Differences between means for Periods

	2	3	4	5	6
1	***	**	***	***	**
2		ns	ns	ns	ns
3			ns	ns	ns
4				ns	*
5					ns

Differences between means for Days

	2
1	ns

Differences between means for Trts

	2
1	*

Differences between means for Reps

	2
1	*

PASTURE SPECIES COMPOSITION - % HOLCUS LANATUS

Source	SS	DF	MS	F
Periods	430.975	5	86.195	12.6377 ***
Days	1.11021	1	1.11021	1.62776 ns
Periods x Days	12.5049	5	2.50099	.366688 ns
Trts	3.86468	1	3.86468	.566627 ns
Periods x Trts	29.4614	5	5.89228	.863908 ns
Days x Trts	21.2534	1	21.2534	3.11611 ns
Reps	22.4407	1	22.4407	3.29018 ns
Error 1	190.974	28	6.82049	

Overall Mean = 3.88625

Treatment Means:

	Periods	Days	Trts	Reps
1	4.81625	4.03833	4.17	3.2025
2	9.205	3.73417	3.6025	4.57
3	5.555			
4	.66125			
5	2.05125			
6	1.02875			
L.S.D. 5%	2.67481	1.5443	1.5443	1.5443
L.S.D. 1%	3.60828	2.08324	2.08324	2.08324
L.S.D. .1%	4.79735	2.76975	2.76975	2.76975

Differences between means for Periods

	2	3	4	5	6
1	**	ns	**	*	**
2		**	***	***	***
3			***	*	**
4				ns	ns
5					ns

Differences between means for Days

	2
1	ns

Differences between means for Trts

	2
1	ns

Differences between means for Reps

	2
1	ns

PASTURE SPECIES COMPOSITION - % TRIFOLIUM SPP.

Source	SS	DF	MS	F
Periods	56.0827	5	11.2165	10.8139 ***
Days	.960502	1	.960502	.926025 ns
Periods x Days	15.2509	5	3.05018	2.94069 *
Trts	.742519	1	.742519	.715866 ns
Periods x Trts	7.10612	5	1.42122	1.37021 ns
Days x Trts	1.62435	1	1.62435	1.56605 ns
Reps	.38521E-2	1	.38521E-2	.371382E-2 ns
Error 1	29.0425	28	1.03723	

Overall Mean = 1.44396

Treatment Means:

	Periods	Days	Trts	Reps
1	2.4025	1.58542	1.56833	1.45292
2	3.30125	1.3025	1.31958	1.435
3	1.41625			
4	.3325			
5	.6175			
6	.59375			
L.S.D. 5%	1.04309	.60223	.60223	.60223
L.S.D. 1%	1.40712	.812399	.812399	.812399
L.S.D. .1%	1.87082	1.08012	1.08012	1.08012

Differences between means for Periods

	2	3	4	5	6
1	ns	ns	***	**	**
2		***	***	***	***
3			*	ns	ns
4				ns	ns
5					ns

Differences between means for Days

	2
1	ns

Differences between means for Trts

	2
1	ns

Differences between means for Reps

	2
1	ns

APPENDIX 56

PASTURE SPECIES COMPOSITION - LOLIUM PERENNE (kg/ha)

Source	SS	DF	MS	F
Periods	.929361E 7	5	.185872E 7	35.0176 ***
Days	.112694E 7	1	.112694E 7	21.2311 ***
Periods x Days	650013	5	130003	2.4492 ns
Trts	.109638E 7	1	.109638E 7	20.6554 ***
Periods x Trts	.113574E	5	227149	4.2794 **
Days x Trts	128361	1	128361	2.41827 ns
Reps	100028	1	100028	1.8845 ns
Error 1	.148623E 7	28	53079.6	

Overall Mean = 729.829

Treatment Means:

	Periods	Days	Trts	Reps
1	1594.13	883.054	880.963	684.179
2	875.963	576.604	578.696	775.479
3	548.888			
4	195.525			
5	707.838			
6	456.638			
L.S.D. 5%	235.966	136.235	136.235	136.235
L.S.D. 1%	318.314	183.779	183.779	183.779
L.S.D. .1%	423.211	244.341	244.341	244.341

Differences between means for Periods

	2	3	4	5	6
1	***	***	***	***	***
2		**	***	ns	**
3			**	ns	ns
4				***	*
5					*

Differences between means for Days

	2
1	***

Differences between means for Trts

	2
1	***

Differences between means for Reps

	2
1	ns

APPENDIX 57

PASTURE SPECIES COMPOSITION - AGROSTIS TENUIS (kg/ha)

Source	SS	DF	MS	F
Periods	.239634E 7	5	479269	12.6687 ***
Days	282609	1	282609	7.47032 *
Periods x Days	80976.8	5	16195.4	.428098 ns
Trts	196288	1	196288	5.18856 *
Periods x Trts	214031	5	42806.1	1.13151 ns
Days x Trts	48813.4	1	48813.4	1.2903 ns
Reps	20012.4	1	20012.4	.528996 ns
Error 1	.105927E 5	28	37830.9	

Overall Mean = 371.165

Treatment Means:

	Periods	Days	Trts	Reps
1	634.85	447.896	435.113	391.583
2	546.288	294.433	307.217	350.746
3	597.638			
4	167.375			
5	144.738			
6	136.1			
L.S.D. 5%	199.209	115.013	115.013	115.013
L.S.D. 1%	268.73	155.151	155.151	155.151
L.S.D. .1%	357.287	206.28	206.28	206.28

Differences between means for Periods

	2	3	4	5	6
1	ns	ns	***	***	***
2		ns	***	***	***
3			***	***	***
4				ns	ns
5					ns

Differences between means for Days

	2
1	*

Differences between means for Trts

	2
1	*

Differences between means for Reps

	2
1	ns

PASTURE SPECIES COMPOSITION - CYNOSURUS CRISTATIS (kg/ha)

Source	SS	DF	MS	F
Periods	.373163E 7	5	746326	11.7073 ***
Days	815.101	1	815.101	.127862E-1 ns
PeriodsxDays	205538	5	41107.5	.644838 ns
Trts	25761.3	1	25761.3	.404108 ns
PeriodsxTrts	31658.9	5	6331.77	.993241E-1 ns
DaysxTrts	889.242	1	889.242	.139492E-1 ns
Reps	336742	1	336742	5.28235 *
Error 1	.178496E 7	28	63748.6	

Overall Mean = 252.875

Treatment Means:

	Periods	Days	Trts	Reps
1	465.938	256.996	276.042	336.633
2	747.188	248.754	229.708	169.117
3	272.5			
4	2.55			
5	19.825			
6	9.25			
L.S.D. 5%	258.595	149.3	149.3	149.3
L.S.D. 1%	348.841	201.403	201.403	201.403
L.S.D. .1%	463.798	267.774	267.774	267.774

Differences between means for Periods

	2	3	4	5	6
1	*	ns	**	**	**
2		***	***	***	***
3			*	ns	*
4				ns	ns
5					ns

Differences between means for Days

	2
1	ns

Differences between means for Trts

	2
1	ns

Differences between means for Reps

	2
1	*

PASTURE SPECIES COMPOSITION - ANTHOXANTHUM ODORATUM (kg/ha)

Source	SS	DF	MS	F
Periods	777971	5	155594	14.8337 ***
Days	7005.92	1	7005.92	.667915 ns
PeriodsxDays	5223.15	5	1044.63	.995907E-1 ns
Trts	1374.95	1	1374.95	.131082 ns
PeriodsxTrts	33541.4	5	6708.28	.639539 ns
DaysxTrts	3893.4	1	3893.4	.371181 ns
Reps	29805.3	1	29805.3	2.84152 ns
Error 1	293699	28	10489.2	

Overall Mean = 131.715

Treatment Means:

	Periods	Days	Trts	Reps
1	297.825	143.796	137.067	156.633
2	312.075	119.633	126.363	106.796
3	116.662			
4	30.125			
5	7.68749			
6	25.9125			
L.S.D. 5%	104.896	60.5615	60.5615	60.5615
L.S.D. 1%	141.502	81.6965	81.6965	81.6965
L.S.D. .1%	188.133	108.619	108.619	108.619

Differences between means for Periods

	2	3	4	5	6
1	ns	**	***	***	***
2		***	***	***	***
3			ns	*	ns
4				ns	ns
5					ns

Differences between means for Days

	2
1	ns

Differences between means for Trts

	2
1	ns

Differences between means for Reps

	2
1	ns

PASTURE SPECIES COMPOSITION - PCA SPP. (kg/ha)

Source	SS	DF	MS	F
Periods	857654	5	171531	5.5307 **
Days	738.685	1	738.685	.238176E-1 ns
PeriodsxDays	201651	5	40330.2	1.30038 ns
Trts	226010	1	226010	7.28727 *
PeriodsxTrts	179137	5	35827.4	1.15519 ns
DaysxTrts	261.8	1	261.8	.844128E-2 ns
Reps	105722	1	105722	3.40882 ns
Error 1	868400	28	31014.3	

Overall Mean = 142.506

Treatment Means:

	Periods	Days	Trts	Reps
1	401.15	146.429	211.125	95.575
2	147.088	138.583	73.8875	189.437
3	205.938			
4	17.0375			
5	29.975			
6	53.85			
L.S.D. 5%	180.371	104.137	104.137	104.137
L.S.D. 1%	243.317	140.479	140.479	140.479
L.S.D. .1%	323.5	186.773	186.773	186.773

Differences between means for Periods

	2	3	4	5	6
1	**	*	***	***	***
2		ns	ns	ns	ns
3			*	ns	ns
4				ns	ns
5					ns

Differences between means for Days

	2
1	ns

Differences between means for Trts

	2
1	*

Differences between means for Reps

	2
1	ns

PASTURE SPECIES COMPOSITION - HOLOUS LANATUS (kg/ha)

Source	SS	DF	MS	F
Periods	.111364E 7	5	22272.7	25.2364 ***
Days	69019.7	1	69019.7	7.82036 **
PeriodsxDays	249786	5	49957.2	5.66046 ***
Trts	25912.1	1	25912.1	2.93601 ns
PeriodsxTrts	110953	5	22190.7	2.51434 ns
DaysxTrts	54.0811	1	54.0811	.612773E-2 ns
Reps	40719.7	1	40719.7	4.61379 *
Error 1	247118	28	8825.64	

Overall Mean = 155.999

Treatment Means:

	Periods	Days	Trts	Reps
1	217.725	193.919	179.233	185.125
2	427.05	118.079	132.765	126.873
3	232.1			
4	11.65			
5	36.1813			
6	11.2875			
L.S.D. 5%	96.2185	55.5518	55.5518	55.5518
L.S.D. 1%	129.797	74.9385	74.9385	74.9385
L.S.D. .1%	172.57	99.6336	99.6336	99.6336

Differences between means for Periods

	2	3	4	5	6
1	***	ns	***	***	***
2		***	***	***	***
3			***	***	***
4				ns	ns
5					ns

Differences between means for Days

	2
1	**

Differences between means for Trts

	2
1	ns

Differences between means for Reps

	2
1	*

PASTURE SPECIES COMPOSITION - TRIFOLIUM SPP. (kg/ha)

Source	SS	DF	MS	F	
Periods	138557	5	27711.3	13.2316	***
Days	14889.6	1	14889.6	7.10947	*
PeriodsxDays	35158.2	5	7031.64	3.35746	*
Trts	5435.77	1	5435.77	2.59546	ns
PeriodsxTrts	14377.3	5	2875.47	1.37297	ns
DaysxTrts	745.764	1	745.764	.356086	ns
Reps	8.33336	1	8.33336	.003979	ns
Error 1	58641.4	28	2094.33		

Overall Mean = 59.2792

Treatment Means:

	Periods	Days	Trts	Reps
1	132.113	76.8917	69.9208	59.6958
2	125.288	41.6667	48.6375	58.8625
3	70.6875			
4	8.4375			
5	8.6375			
6	10.5125			
L.S.D. 5%	46.8714	27.0612	27.0612	27.0612
L.S.D. 1%	63.2288	36.5052	36.5052	36.5052
L.S.D. .1%	84.0652	48.5351	48.5351	48.5351

Differences between means for Periods

	2	3	4	5	6
1	ns	*	***	***	***
2		*	***	***	***
3			*	*	*
4				ns	ns
5					ns

Differences between means for Days

	2
1	*

Differences between means for Trts

	2
1	ns

Differences between means for Reps

	2
1	ns

APPENDIX 63.

STRATA PASTURE SPECIES

P E R I O D	D A Y	T R E A T M E N T	Rep	LOpe	ASte	CYcr	ANod	POan	HOLA	DAgl	BRmo	FERu	TRspp	Weeds	Dead Matter		
			Strata														
I	1	L	A-T	949.6	164.2	482.2	187.8	144.0	103.2					60.6			
			%	41.87	7.24	21.26	8.28	6.35	4.77						2.67	6.25	1.25
			A-B	730.2	820.3	116.3	159.7	430.3	69.9						111.4		
			%	19.53	21.94	3.11	4.27	11.51	1.87						2.98		17.87
			B-T	944.9	20.2	44.3		149.6	1.3	3.9					5.1		
			%	77.64	1.66	3.64		12.29	0.11	0.32					0.42		3.88
		H	B-B	1532.7	744.5	61.6	205.6	633.2	72.6						87.5		
			%	36.09	17.53	1.45	4.84	14.91	1.71						2.06		21.39
			A-T	367.9	67.1	206.7	27.1	36.8	26.5	0.5					18.2		
			%	46.92	8.56	26.36	3.46	4.70	3.38	0.06					2.32	3.66	0.53
			A-B	954.4	1114.3	49.8	303.1	225.6	414.4						130.7		
			%	25.13	29.34	1.31	7.98	5.94	10.91						3.44	1.56	14.35
	3	L	B-T	171.4	4.4	220.6	23.2	18.0	5.8	0.5				19.3			
			%	37.01	0.94	47.66	5.02	3.90	1.26	0.11				0.30	3.93	0.80	
			B-B	1004.8	208.5	168.6	380.2	246.9	218.2					147.8			
			%	33.25	6.90	5.58	12.58	8.17	7.22					0.09	4.89	7.13	14.11
			A-T	948.7	42.7	453.1	198.3	69.1	168.6			21.3			23.9		
			%	48.45	2.18	23.14	10.13	3.53	8.61			1.09			1.22		1.62
	3	H	A-B	773.2	248.2	666.1	308.2	268.6	215.9					208.0			
			%	23.46	7.53	20.21	9.35	8.15	6.55					6.31	0.20	18.20	
			B-T	970.6	145.5	67.1		254.7	31.2			8.8		2.3			
			%	60.36	9.05	4.17		15.84	1.94			0.55		0.14		7.90	
			B-B	1251.3	382.0	118.7	65.4	287.5	26.0					69.7			
			%	40.39	12.33	3.83	2.11	9.28	0.84					2.25		28.94	
3	L	A-T	475.9	78.0	445.2	31.6	41.6	110.7									
		%															

contd.

contd.

		%	38.91	6.38	36.40	2.58	3.40	9.05		0.72	2.52
		A-B	969.6	632.4	174.8	283.2	228.0	135.3	42.2		
		%	32.18	20.99	5.80	9.40	7.57	4.49	1.40	0.74	17.39
		B-T	261.2	6.6	237.1	24.4	29.5	13.7	2.4		
		%	44.50	1.12	40.39	4.16	5.03	2.33	0.41	1.15	0.85
		B-B	446.6	399.9	215.3	184.8	145.7	123.5	127.8		
		%	21.70	19.43	10.46	8.98	7.08	6.00	6.21	2.21	17.88
II	1	L	A-T	453.4	282.0	928.9	68.7	305.3	1.0		
		%	22.04	13.71	45.16	3.34	14.84	0.05			0.82
		A-B	328.5	569.9	439.0	443.1	56.1	518.1	278.7		
		%	9.77	16.95	13.06	13.18	1.67	15.41	8.29	3.38	18.34
		B-T	793.6	115.7	211.4	64.3	58.0	57.6	16.6		
		%	52.18	7.61	13.90	4.23	3.81	3.79	1.09	2.06	11.29
		B-B	65.9	845.2	126.9	282.2	616.1	621.0	178.0		
		%	1.34	17.19	2.58	5.74	12.53	12.63	3.62	1.55	42.78
		H	A-T	198.6	32.1	536.4	18.9	1.0	91.7	3.0	
		%	21.02	3.40	56.76	2.00	0.11	9.70	0.32	2.09	4.55
		A-B	429.6	210.8	439.6	179.4	21.9	273.2	174.2		
		%	17.63	8.65	18.04	7.36	0.90	11.21	7.15	10.88	18.11
		B-T	355.1	114.0	347.2	43.2	1.3	176.0	20.6		
		%	31.07	9.97	30.38	3.78	0.11	15.40	1.80	3.70	3.73
		B-B	842.7	292.6	136.7	253.5	10.4	457.0	139.1		
		%	27.62	9.59	4.48	8.31	0.34	14.98	4.56	1.72	28.34
	3	L	A-T	637.7	143.1	1213.4	105.4	154.9			
		%	26.92	6.04	51.22	4.45	6.54				4.79
		A-B	506.3	337.5	160.6	451.2	18.7	221.3	44.7		
		%	17.91	11.94	5.68	15.96	0.66	7.83	1.58		38.40
		B-T	729.8	109.7	79.0	41.8	38.1	16.2	3.2		
		%	59.53	8.95	6.44	3.41	3.11	1.32	0.26		16.94
		B-B	741.4	328.1	116.7	22.8	236.7	74.2	63.3		
		%	26.69	11.81	4.20	0.82	8.52	2.67	2.28		42.97
		H	A-T	256.7	52.0	519.8	18.5	0.7	35.3	11.1	
		%	26.66	5.40	53.98	1.92	0.07	3.67	1.15		7.11
		A-B	281.9	550.0	115.7	156.3	22.2	221.2	49.0		
		%	12.30	24.00	5.05	6.82	0.97	9.65	2.14		39.03
		B-T	156.7	33.0	378.1	25.9	5.2	60.2			
		%	21.82	4.60	52.66	3.61	0.72	8.39		0.46	5.70

contd.

contd.

		B-B	229.8	354.6	228.1	321.4	90.3	133.2		23.0			
		%	9.87	15.23	9.80	13.81	3.88	5.72		0.99	0.20	40.46	
III	1	L	A-T	452.4	295.9	633.7	34.9	4.4	132.6		4.4		
			%	20.61	13.48	28.87	1.59	0.20	6.04		0.20	4.36	24.60
			A-B	476.9	629.9	12.9	68.5	18.3	208.3	6.3	81.4		
			%	15.11	19.96	0.41	2.17	0.58	6.60	0.20	2.58		52.35
			B-T	414.0	269.9	181.2	24.8	17.8	141.3		0.7		
			%	18.19	11.86	7.96	1.09	0.78	6.21		0.03		53.84
			B-B	555.5	545.5	46.4	3.5	139.5	153.7	5.2	118.7		
			%	16.05	15.76	1.34	0.10	4.03	4.44	0.15	3.43		54.66
		H	A-T	19.1	39.6	44.3	3.0		17.9				
			%	2.83	5.87	6.58	0.45		2.66			1.57	80.01
			A-B	302.3	201.0	154.4	94.2	106.4	90.3		75.2		
			%	13.39	8.90	6.84	4.17	4.71	4.00		3.33	0.57	54.03
			B-T	49.6	301.6	319.9	8.9		6.5		1.5		
			%	3.59	21.81	23.13	0.64		0.47		0.11	1.02	49.20
			B-B	514.6	474.3	31.6	246.4	10.2	154.5	17.6	33.2	10.5	
			%	16.12	14.86	0.99	7.72	0.32	4.84	0.55	1.04	0.33	51.37
	3	L	A-T	166.8	311.1	18.5	36.3	9.0	7.2	1.1			
			%	11.12	20.74	1.23	2.42	0.60	0.48	0.07		3.97	59.32
			A-B	240.1	375.2	133.4	124.6	21.6	452.0		18.5		
			%	7.13	11.14	3.96	3.70	0.64	13.42		0.55	0.91	58.50
			B-T	257.1	231.4	163.0	14.7	54.5	36.8	1.8			
			%	11.18	10.06	7.09	0.64	2.37	1.60	0.08			66.96
			B-B	517.2	408.3		94.7	1023.8	207.8		234.1		
			%	9.83	7.76		1.80	19.46	3.95		4.45		52.71
		H	A-T	37.7	54.3	25.0	1.0	4.3	9.2				
			%	7.94	11.44	5.26	0.22	0.91	1.93				72.25
			A-B	259.3	151.1	21.0	145.8	127.3	209.2		19.9		
			%	9.37	5.46	0.76	5.27	4.60	7.56		0.72	0.17	66.06
			B-T	21.0	67.3	255.5			6.6		0.6		
			%	3.57	11.44	43.48			1.13		0.11		40.24
			B-B	107.5	424.7	139.2	32.0	110.4	22.9				
			%	5.54	21.88	7.17	1.65	5.69	1.18				56.86

STRATA PASTURE SPECIES COMPOSITION - % LOLIUM PERENNE

Source	SS	DF	MS	F
Periods	6502.39	2	3251.19	42.8941 ***
Days	17.1243	1	17.1243	.225928 ns
PeriodsxDays	110.068	2	55.0342	.726086 ns
Trts	556.581	1	556.581	7.34318 *
PeriodsxTrts	17.6853	2	8.84264	.116664 ns
DaysxTrts	60.2336	1	60.2336	.794683 ns
Reps	449.759	1	449.759	5.93383 *
Strata	1734.37	1	1734.37	22.8821 ***
PeriodsxStrata	1148.76	2	574.378	7.57797 **
DaysxStrata	.880191E-2	1	.880191E-2	.116127E-3 ns
TrtsxStrata	567.531	1	567.531	7.48764 *
Error 1	2425.46	32	75.7957	

Overall Mean = 24.6527

Treatment Means:

	Periods	Days	Trts	Reps	Strata
1	39.2119	25.25	28.0579	21.5917	30.6638
2	24.0231	24.0554	21.2475	27.7138	18.6417
3	10.7231				
L.S.D. 5%	6.26979	5.11927	5.11927	5.11927	5.11927
L.S.D. 1%	8.42922	6.88243	6.88243	6.88243	6.88243
L.S.D. .1%	11.148	9.10232	9.10232	9.10232	9.10232

Differences between means for Periods

	2	3
1	***	***
2		***

Differences between means for Days

	2
1	ns

Differences between means for Trts

	2
1	*

Differences between means for Reps

	2
1	*

Differences between means for Strata

	2
1	***

STRATA PASTURE SPECIES COMPOSITION - % AGROSTIS TENUIS

Source	SS	DF	MS	F	
Periods	61.3634	2	30.6817	.960778	ns
Days	14.941	1	14.941	.467868	ns
PeriodsxDays	9.25126	2	4.62563	.144849	ns
Trts	1.42141	1	1.42141	.445105E-1	ns
PeriodsxTrts	27.5123	2	13.7562	.430766	ns
DaysxTrts	85.1734	1	85.1734	2.66715	ns
Reps	9.99188	1	9.99188	.312889	ns
Strata	491.264	1	491.264	15.3836	***
PeriodsxStrata	313.394	2	156.697	4.90686	*
DaysxStrata	1.8252	1	1.8252	.057155	ns
TrtsxStrata	25.5792	1	25.5792	.800997	ns
Error 1	1021.9	32	31.9342		

Overall Mean = 11.6788

Treatment Means:

	Periods	Days	Trts	Reps	Strata
1	10.82	12.2367	11.8508	12.135	8.47959
2	10.94	11.1208	11.5067	11.2225	14.8779
3	13.2763				
L.S.D. 5%	4.06967	3.32287	3.32287	3.32287	3.32287
L.S.D. 1%	5.47133	4.46732	4.46732	4.46732	4.46732
L.S.D. .1%	7.23608	5.90824	5.90824	5.90824	5.90824

Differences between means for Periods

	2	3
1	ns	ns
2		ns

Differences between means for Days

	2
1	ns

Differences between means for Trts

	2
1	ns

Differences between means for Reps

	2
1	ns

Differences between means for Strata

	2
1	***

STRATA PASTURE SPECIES COMPOSITION - % CYNOSURUS CRISTATIS

Source	SS	DF	MS	F
Periods	1629.89	2	814.946	6.16427 **
Days	20.7113	1	20.7113	1.5666 ns
PeriodsxDays	56.2424	2	28.1212	.212709 ns
Trts	1058.54	1	1058.54	8.00678 **
PeriodsxTrts	95.2861	2	47.643	.360373 ns
DaysxTrts	62.2669	1	62.2669	.470988 ns
Reps	241.517	1	241.517	1.82684 ns
Strata	5229.4	1	5229.4	39.5552 ***
PeriodsxStrata	684.595	2	342.298	2.58915 ns
DaysxStrata	.321769	1	.321769	.243386E-2 ns
TrtsxStrata	772.086	1	772.086	5.84007 *
Error 1	4230.56	32	132.205	

Overall Mean = 16.109

Treatment Means:

	Periods	Days	Trts	Reps	Strata
1	15.9231	15.4521	11.4129	18.3521	26.5467
2	23.3359	16.7658	20.805	13.8658	5.67125
3	9.06688				
L.S.D. 5%	8.28046	6.76097	6.76097	6.76097	6.76097
L.S.D. 1%	11.1324	9.08956	9.08956	9.08956	8.08956
L.S.D. .1%	14.7231	12.0214	12.0214	12.0214	12.0214

Differences between means for Periods

	2	3
1	ns	ns
2		**

Differences between means for Days

	2
1	ns

Differences between means for Trts

	2
1	**

Differences between means for Reps

	2
1	ns

Differences between means for Strata

	2
1	***

STRATA PASTURE SPECIES COMPOSITION - % ANTHOXANTHUM ODORATUM

Source	SS	DF	MS	F	
Periods	162.752	2	81.3762	8.27164	**
Days	.172522E-1	1	.172522E-1	.175364E-2	ns
PeriodsxDays	.809679	2	.40484	.411507E-1	ns
Trts	6.95402	1	6.95402	.706855	ns
PeriodsxTrts	10.9532	2	5.47658	.556678	ns
DaysxTrts	2.52542	1	2.52542	.256701	ns
Reps	26.1518	1	26.1518	2.65825	ns
Strata	171.272	1	171.272	17.4093	***
PeriodsxStrata	22.4571	2	11.2285	1.14135	ns
DaysxStrata	.526687E-1	1	.526687E-1	.535362E-2	ns
TrtsxStrata	36.3138	1	36.3138	3.69119	ns
Error 1	314.815	32	9.83797		

Overall Mean = 4.69813

Treatment Means:

	Periods	Days	Trts	Reps	Strata
1	5.82125	4.67917	4.3175	5.43625	2.80917
2	6.17125	4.71708	5.07875	3.96	6.58708
3	2.10188				
L.S.D. 5%	2.25883	1.84433	1.84433	1.84433	1.84433
L.S.D. 1%	3.03681	2.47955	2.47955	2.47955	2.47955
L.S.D. .1%	4.01632	3.27931	3.27931	3.27931	3.27931

Differences between means for Periods

	2	3
1	ns	**
2		***

Differences between means for Days

	2
1	ns

Differences between means for Trts

	2
1	ns

Differences between means for Reps

	2
1	ns

Differences between means for Strata

	2
1	***

STRATA PASTURE SPECIES COMPOSITION - % POA SPP

Source	SS	DF	MS	F
Periods	306.383	2	153.191	13.4554 ***
Days	4.826	1	4.826	.423886 ns
PeriodsxDays	33.2469	2	16.6234	1.4601 ns
Trts	110.11	1	110.11	9.67139 **
PeriodsxTrts	19.0729	2	9.53645	.837622 ns
DaysxTrts	1.40768	1	1.40768	.123641 ns
Reps	112.241	1	112.241	9.85853 **
Strata	118.064	1	118.064	10.37 **
PeriodsxStrata	9.79496	2	4.89748	.430164 ns
DaysxStrata	.896534	1	.896534	.787459E-1 ns
TrtsxStrata	2.44803	1	2.44803	.21502 ns
Error 1	364.325	32	11.3851	

Overall Mean = 4.35292

Treatment Means:

	Periods	Days	Trts	Reps	Strata
1	7.91563	4.03583	5.8675	2.82375	2.78458
2	2.3375	4.67	2.83833	5.88208	5.92125
3	2.80563				
L.S.D. 5%	2.42997	1.98406	1.98406	1.98406	1.98406
L.S.D. 1%	3.26689	2.6674	2.6674	2.6674	2.6674
L.S.D. .1%	4.32061	3.52776	3.52776	3.52776	3.52776

Differences between means for Periods

	2	3
1	***	***
2		ns

Differences between means for Days

	2
1	ns

Differences between means for Trts

	2
1	**

Differences between means for Reps

	2
1	**

Differences between means for Strata

	2
1	**

STRATA PASTURE SPECIES COMPOSITION - % HOLCUS LANATUS

Source	SS	DF	MS	F
Periods	234.86	2	117.43	12.272 ***
Days	47.2034	1	47.2034	4.93296 *
PeriodsxDays	128.51	2	64.2548	6.7149 **
Trts	3.4992	1	3.4992	.365682 ns
PeriodsxTrts	51.4992	2	25.7496	2.69095 ns
DaysxTrts	.106408	1	.106408	.11201E-1 ns
Reps	77.6226	1	77.6226	8.1119 **
Strata	52.2084	1	52.2084	5.45601 *
PeriodsxStrata	9.39053	2	4.69527	.490676 ns
DaysxStrata	.3888	1	.3888	.406313E-1 ns
TrtsxStrata	.9408	1	.9408	.983177E-1 ns
Error 1	306.207	32	9.56898	

Overall Mean = 5.86042

Treatment Means:

	Periods	Days	Trts	Reps	Strata
1	4.44	6.85208	5.59042	7.13208	4.8175
2	8.98438	4.86875	6.13042	4.58875	6.90333
3	4.15688				
L.S.D. 5%	2.22774	1.81894	1.81894	1.81894	1.81894
L.S.D. 1%	2.99501	2.44541	2.44541	2.44541	2.44541
L.S.D. .1%	3.96103	3.23417	3.23417	3.23417	3.23417

Differences between means for Period

	2	3
1	***	ns
2		***

Differences between means for Days

	2
1	*

Differences between means for Trts

	2
1	ns

Differences between means for Reps

	2
1	**

Differences between means for Strata

	2
1	*

STRATA PASTURE SPECIES COMPOSITION - % TRIFOLIUM SPP.

Source	SS	DF	MS	F	
Periods	17.093	2	8.54651	3.67038	*
Days	12.0601	1	12.0601	5.17932	*
PeriodsxDays	11.0624	2	5.5312	2.37543	ns
Trts	.425634	1	.425634	.182793	ns
PeriodsxTrts	2.47287	2	1.23643	.530999	ns
DaysxTrts	.957675	1	.957675	.411283	ns
Reps	1.65763	1	1.65763	.711887	ns
Strata	83.2133	1	83.2133	35.7368	***
PeriodsxStrata	4.05462	2	2.02731	.870648	ns
DaysxStrata	2.75521	1	2.75521	1.18325	ns
TrtsxStrata	.730133	1	.730133	.313563	ns
Error 1	74.5122	32	2.32851		

Overall Mean = 1.83083

Treatment Means:

	Periods	Days	Trts	Reps	Strata
1	2.31375	2.33208	1.925	2.01667	.514167
2	2.18875	1.32958	1.73667	1.645	3.1475
3	.99				
L.S.D. 5%	1.09893	.897272	.897272	.897272	.897272
L.S.D. 1%	1.47742	1.20631	1.20631	1.20631	1.20631
L.S.D. .1%	1.95395	1.5954	1.5954	1.5954	1.5954

Differences between means for Periods

	2	3
1	ns	*
2		*

Differences between means for Days

	2
1	*

Differences between means for Trts

	2
1	ns

Differences between means for Reps

	2
1	ns

Differences between means for Strata

	2
1	***

STRATA PASTURE SPECIES COMPOSITION - LOLIUM PERENNE (kg/ha)

Source	SS	DF	MS	F
Periods	.228701E 7	2	.114351E 7	28.7302 ***
Days	57657.6	1	57657.6	1.48863 ns
PeriodsxDays	48876.7	2	24438.4	.614005 ns
Trts	941865	1	941865	23.664 ***
PeriodsxTrts	139004	2	69502.2	1.74622 ns
DaysxTrts	63714.6	1	63714.6	1.60081 ns
Reps	61504.4	1	61504.4	1.54528 ns
Strata	328815	1	328815	8.26137 **
PeriodsxStrata	237600	2	118800	2.98481 ns
DaysxStrata	28236.7	1	28236.7	.709437 ns
TrtsxStrata	328617	1	328617	8.25638 **
Error 1	.127365E 7	32	39801.6	

Overall Mean = 503.163

Treatment Means:

	Periods	Days	Trts	Reps	Strata
1	797.063	537.821	643.242	467.367	420.396
2	437.981	468.504	363.083	538.958	585.929
3	274.444				
L.S.D. 5%	143.675	117.31	117.31	117.31	117.31
L.S.D. 1%	193.159	157.714	157.714	157.714	157.714
L.S.D. .1%	255.461	208.583	208.583	208.583	208.583

Differences between means for Periods

	2	3
1	***	***
2		*

Differences between means for Days

	2
1	ns

Differences between means for Trts

	2
1	***

Differences between means for Reps

	2
1	ns

Differences between means for Strata

	2
1	**

STRATA PASTURE SPECIES COMPOSITION - AGROSTIS TENUIS (kg/ha)

Source	SS	DF	MS	F	
Periods	15819.9	2	7909.94	.291525	ns
Days	129875	1	129875	4.78662	*
PeriodsxDays	14261.8	2	7130.91	.262813	ns
Trts	130396	1	130396	4.80581	*
PeriodsxTrts	58809.4	2	29404.7	1.08373	ns
DaysxTrts	82005.3	1	82005.3	3.02235	ns
Reps	6892.82	1	6892.82	.254039	ns
Strata	.142396E 7	1	.142396E 7	52.4807	***
PeriodsxStrata	179458	2	89728.8	3.307	*
DaysxStrata	55542.4	1	55542.4	2.04705	ns
TrtsxStrata	77.521	1	77.521	.285708E-2	ns
Error 1	868255	32	27133		

Overall Mean = 296.463

Treatment Means:

	Periods	Days	Trts	Reps	Strata
1	317.425	348.479	348.583	308.446	124.225
2	273.144	244.446	244.342	284.479	468.7
3	298.819				
L.S.D. 5%	118.626	96.8576	96.8576	96.8576	96.8576
L.S.D. 1%	159.483	130.217	130.217	130.217	130.217
L.S.D. .1%	210.923	172.218	172.218	172.218	172.218

Differences between means for Periods

	2	3
1	ns	ns
2		ns

Differences between means for Days

	2
1	*

Differences between means for Trts

	2
1	*

Differences between means for Reps

	2
1	ns

Differences between means for Strata

	2
1	***

STRATA PASTURE SPECIES COMPOSITION - CYNOSURUS CRISTATUS (kg/h

Source	SS	DF	MS	F
Periods	455797	2	227899	5.10351 *
Days	.300793	1	.300793	.673588E-5 ns
PeriodsxDays	101778	2	50889	1.1396 ns
Trts	23576.5	1	23576.5	.527966 ns
PeriodsxTrts	4795.99	2	2398	.537002E-1 ns
DaysxTrts	785.7	1	785.7	.175948E-1 ns
Reps	349628	1	349628	7.82949 **
Strata	356765	1	546765	7.98931 **
PeriodsxStrata	115992	2	57995.8	1.29874 ns
DaysxStrata	7696.27	1	7696.27	.172349 ns
TrtsxStrata	13878.8	1	13878.8	.310799 ns
Error 1	.142897E 7	32	44655.3	

Overall Mean = 247.604

Treatment Means:

	Periods	Days	Trts	Reps	Strata
1	232.969	247.525	269.767	332.95	333.817
2	373.594	247.683	225.442	162.258	161.392
3	136.25				
L.S.D. 5%	152.183	124.257	124.257	124.257	124.257
L.S.D. 1%	204.598	167.054	167.054	167.054	167.054
L.S.D. .1%	270.59	220.936	220.936	220.936	220.936

Differences between means for Periods

	2	3
1	ns	ns
2		**

Differences between means for Days

	2
1	ns

Differences between means for Trts

	2
1	ns

Differences between means for Reps

	2
1	**

Differences between means for Strata

	2
1	**

STRATA PASTURE SPECIES COMPOSITION - ANTHOXANTHUM ODORATUM (kg/h)

Source	SS	DF	MS	F
Periods	94945.3	2	47472.7	6.18384 **
Days	3958.52	1	3958.52	.515641 ns
PeriodsxDays	1150.02	2	575.012	.749017E-1 ns
Trts	837.506	1	837.506	.109094 ns
PeriodsxTrts	14669.7	2	7334.84	.955444 ns
DaysxTrts	1592.76	1	1592.76	.207474 ns
Reps	24530	1	24530	3.19531 ns
Strata	301959	1	301959	39.3334 ***
PeriodsxStrata	35166.2	2	17583.1	2.29039 ns
DaysxStrata	3711.84	1	3711.84	.483508 ns
TrtsxStrata	16953.8	1	16953.8	2.20843 ns
Error 1	245661	32	7676.89	

Overall Mean = 121.094

Treatments Means:

	Periods	Days	Trts	Reps	Strata
1	148.913	130.175	125.271	143.7	41.7792
2	156.038	112.013	116.917	98.4875	200.408
3	58.3313				
L.S.D. 5%	63.0992	51.5203	51.5203	51.5203	51.5203
L.S.D. 1%	84.8316	69.2647	69.2647	69.2647	69.2647
L.S.D. .1%	112.194	91.6057	91.6057	91.6057	91.6057

Differences between means for Periods

	2	3
1	ns	**

Differences between means for Days

	2
1	ns

Differences between means for Trts

	2
1	ns

Differences between means for Reps

	2
1	ns

Differences between means for Strata

	2
1	***

STRATA PASTURE SPECIES COMPOSITION - POA SPP. (kg/ha)

Source	SS	DF	MS	F	
Periods	138915	2	69457.4	2.54805	ns
Days	138.72	1	138.72	.508894E-2	ns
PeriodsxDays	89020.5	2	44510.2	1.63286	ns
Trts	188251	1	188251	6.90598	*
PeriodsxTrts	6484.6	2	3242.3	.118944	ns
DaysxTrts	55.9008	1	55.9008	.205072E-2	ns
Reps	106540	1	106540	3.90843	ns
Strata	370692	1	370692	13.5988	***
PeriodsxStrata	19172.1	2	9586.07	.351665	ns
DaysxStrata	102.083	1	102.083	.374493E-2	ns
TrtsxStrata	59108.4	1	59108.4	2.16839	ns
Error 1	872291	32	27259.1		

Overall Mean = 126.946

Treatment Means:

	Periods	Days	Trts	Reps	Strata
1	200.575	125.246	189.571	79.8333	39.0667
2	73.5438	128.646	64.3208	174.058	214.825
3	106.719				
L.S.D. 5%	118.901	97.0825	97.0825	97.0825	97.0825
L.S.D. 1%	159.853	130.519	130.519	130.519	130.519
L.S.D. .1%	211.413	172.618	172.618	172.618	172.618

Differences between means for Periods

	2	3
1	*	ns
2		ns

Differences between means for Days

	2
1	ns

Differences between means for Trts

	2
1	*

Differences between means for Reps

	2
1	ns

Differences between means for Strata

	2
1	***

STRATA PASTURE SPECIES COMPOSITION - HOLOCUS LANATUS (kg/ha)

Source	SS	DF	MS	F
Periods	109372	2	54686.1	5.4822 **
Days	55270.6	1	55270.6	5.5408 *
PeriodsxDays	102091	2	51045.7	5.11726 *
Trts	20377.5	1	20377.5	2.04282 ns
PeriodsxTrts	46716.4	2	23358.2	2.34163 ns
DaysxTrts	111.63	1	111.63	.111908E-1 ns
Reps	39640.5	1	39640.5	3.97391 ns
Strata	265876	1	265876	26.6537 ***
PeriodsxStrata	20850.9	2	10425.5	1.04514 ns
DaysxStrata	12956	1	12956	1.29883 ns
TrtsxStrata	946.963	1	946.963	.949317E-1 ns
Error 1	319206	32	9975.2	

Overall Mean = 146.146

Treatment Means:

	Periods	Days	Trts	Reps	Strata
1	108.863	180.079	166.75	174.883	71.7208
2	213.525	112.213	125.542	117.408	220.571
3	116.05				
L.S.D. 5%	71.927	58.7281	58.7281	58.7281	58.7281
L.S.D. 1%	96.6998	78.9551	78.9551	78.9551	78.9551
L.S.D. .1%	127.89	104.422	104.422	104.422	104.422

Differences between means for Periods

	2	3
1	**	ns
2		**

Differences between means for Days

	2
1	*

Differences between means for Trts

	2
1	ns

Differences between means for Reps

	2
1	ns

Differences between means for Strata

	2
1	***

STRATA PASTURE SPECIES COMPOSITION - TRIFOLIUM SPP. (kg/ha)

Source	SS	DF	MS	F	
Periods	9067.7	2	4533.85	1.98067	ns
Days	11522.7	1	11522.7	5.03384	*
PeriodsxDays	13213.2	2	6606.62	2.88618	ns
Trts	7313.67	1	7313.67	3.19507	ns
PeriodsxTrts	2394.29	2	1197.14	.522987	ns
DaysxTrts	709.172	1	709.172	.309811	ns
Reps	159.505	1	159.505	.696818E-1	ns
Strata	104729	1	104729	45.7524	***
PeriodsxStrata	3951.91	2	1975.96	.863221	ns
DaysxStrata	5683.28	1	5683.28	2.48281	ns
TrtsxStrata	5562.06	1	5562.06	2.42986	ns
Error 1	73249.6	32	2289.05		

Overall Mean = 54.6813

Treatment Means:

	Periods	Days	Trts	Reps	Strata
1	66.0563	70.175	67.025	56.5042	7.97084
2	62.6438	39.1875	42.3375	52.8583	101.392
3	35.3438				
L.S.D. 5%	34.4555	28.1328	28.1328	28.1328	28.1328
L.S.D. 1%	46.3226	37.8222	37.8222	37.8222	37.8222
L.S.D. .1%	61.2637	50.0216	50.0216	50.0216	50.0216

Differences between means for Periods

	2	3
1	ns	ns
2		ns

Differences between means for Days

	2
1	*

Differences between means for Trts

	2
1	ns

Differences between means for Reps

	2
1	ns

Differences between means for Strata

	2
1	***

APPENDIX 78 WEED SPECIES - PERCENTAGE CONTRIBUTION

P E R I O D	D A Y	T R E A T M E N T	Rep-	HYra	BEpe	LEle	PLla	TAof	Moss	Rush spp.	CEgl
			Strata %								
I	1	L	A-T	0.81			5.44				
			H	A-T	0.58			3.08			
			A-B				1.56				
			B-T			2.78	1.15				
			B-B	0.15	0.42	0.79	4.04	1.73			
	3	L	A-B			0.20					
			H	A-T				0.72			
			A-B			0.74					
			B-T	0.60			0.55				
			B-B			0.42	1.79				
II	1	L	A-B			0.72	2.56				
			B-T	2.06							
			B-B	1.55							
		H	A-T				2.09				
			A-B			0.19	10.69				
		B-T			1.74	1.96					
		B-B		0.22	0.19	1.31					
		3	H	B-T							2.46
	B-B					0.2					

contd.

contd.

III	1	L	A-T					4.36		
		H	A-T	1.57						
			A-B		0.23					0.34
			B-T					1.02		
			B-B				1.79			
	3	L	A-T					3.97		
			A-B	0.13	0.47	0.31				
		H	A-B			0.17				
IV	1	L	A				0.14			
V	3	H	A B			0.48		0.10		
VI	1	H	A			2.80				
			B			1.91				

APPENDIX 79.

OESOPHAGEAL FISTULA SHEEP LIVeweIGHTS

Treatment	Tag No.	Liveweight (kg)	
		10-10-77 (pre-trial)	26-5-78 (post-trial)
L	4	51	60
	6	50	51
	10	50	42
	18	54	42
H	1	57	61
	7	50	53
	9	52	52
	11	51	45
	15	51	45
	17	57	54

APPENDIX 80.

MEAN MONTHLY METEOROLOGICAL DATA

	Rainfall mm		10 cm Soil Temp °C		Windspeed km/hr	
	(Mean 1970-78)		(Mean 1970-78)		(Mean 1970-78)	
Jan 1978	16.6	(84.2)	16.7	(16.5)	30.7	(28.2)
Feb 1978	15.8	(58.3)	17.5	(16.2)	27.7	(26.4)
Mar 1978	30.6	(86.5)	15.6	(14.8)	28.6	(25.1)
Apr 1978	140.8	(95.3)	13.6	(12.6)	20.9	(26.4)
May 1978	66.8	(110.7)	9.5	(9.3)	23.7	(30.8)
June 1977	159.4	(118.6)	7.6	(7.4)	30.5	(26.8)
July 1977	90.4	(138.5)	6.4	(6.6)	18.4	(27.1)
Aug 1977	71.0	(95.9)	7.6	(7.1)	22.6	(25.7)
Sept 1977	179.0	(114.5)	7.3	(8.8)	28.6	(29.6)
Oct 1977	50.6	(115.5)	10.0	(10.4)	34.2	(31.4)
Nov 1977	87.6	(85.3)	11.7	(13.0)	32.5	(30.1)
Dec 1977	129.1	(89.6)	14.7	(15.1)	31.7	(29.3)

APPENDIX 81.

DAILY METEOROLOGICAL DATA FOR MEASUREMENT PERIODS

	Rainfall mm	10cm Soil Temp °C	Windrun km/h
I			
Tues 20-12-77	0.0	15.0	22.5
Wed 21-12-77	0.6	14.2	22.9
Thur 22-12-77	0.8	13.9	11.7
II			
Tues 17-1-78	0.0	16.5	23.3
Wed 18-1-78	0.0	16.9	22.7
Thur 19-1-78	0.0	17.0	21.9
III			
Tues 14-2-78	0.0	18.0	13.9
Wed 15-2-78	0.4	18.8	17.3
Thur 16-2-78	5.3	18.1	11.7
IV			
Tues 11-4-78	0.1	13.6	21.6
Wed 12-4-78	0.0	11.7	19.3
Thur 13-4-78	0.0	13.0	19.3
V			
Tues 2-5-78	0.1	12.0	11.8
Wed 3-5-78	0.2	10.7	15.7
Thur 4-5-78	3.6	9.0	22.9
VI			
Tues 23-5-78	0.0	8.8	31.8
Wed 24-5-78	1.0	7.9	29.1
Thur 25-5-78	0.2	7.6	26.2

BIBLIOGRAPHY

- Alder, F.E. (1969). The use of cattle with oesophageal fistulae in grassland experiments. *J. Br. Grassld. Soc.* 24: 6-
- Allden, W.G. (1962). Rate of herbage intake and grazing time in relation to herbage availability. *Proc. Aust. Soc. Anim. Prod.* 4: 163-166.
- Allden, W.G. (1968). Undernutrition of the Merino sheep and its sequelae. IV. Herbage consumption and utilization of feed for wool production following growth restrictions imposed at two stages of early post-natal life in a mediterranean environment. *Aust. J. Agric. Res.* 19: 997-1007.
- _____, Whittaker, I.A. McD (1970). The determinants of herbage intake by grazing sheep. The interrelationship of factors influencing herbage intake and availability. *Aust. J. Agric. Res.* 21: 755-66.
- Arnold, G.W. (1960a). Selective grazing by sheep of two forage species at different stages of growth. *Aust. J. Agric. Res.* 11(6): 1026-1033.
- _____ (1960b). The effect of the quantity and quality of pasture available to sheep on their grazing behaviour. *Aust. J. Agric. Res.* 11(6): 1034-1043.
- _____ (1962). Effects of pasture maturity on the diet of sheep. *Aust. J. Agric. Res.* 13(4): 701-706.
- _____ (1963). The grazing behaviour of sheep. *Wool Technol. Sheep Brd.* 10: 17-19.
- _____ (1964). Factors within plant association affecting the behaviour and performance of grazing

- animals. In 'Grazing in terrestrial and marine environments'. Ed. D.J. Crisp. p. 133-154.
- Arnold, G.W. (1964b). Some principles in the investigation of selective grazing. Proc. Aust. Soc. Anim. Prod. 5: 258-71.
- _____ (1964d) Responses of lambs to differing pasture conditions. Proc. Aust. Soc. Anim. Prod. 5: 275-279.
- _____ (1966a). The special senses in grazing animals. 1. Sight and dietary habits in sheep. Aust. J. Agric. Res. 17: 521-529.
- _____ (1966b). The special senses in grazing animals. 2. Smell, taste and touch, and dietary habits in sheep. Aust. J. Agric. Res. 17: 531-542.
- _____ (1970). Regulation of food intake in grazing ruminants. In 'Physiology of digestion and metabolism in the ruminant'. Ed. A.T. Phillipson. p. 264-276.
- _____ (1975). Herbage intake and grazing behaviour in ewes of four breeds at different physiological states. Aust. J. Agric. Res. 26, 1017-24.
- _____, McManus, W.R., Bush, I.G., Ball, Judith (1964). The use of sheep fitted with oesophageal fistulas to measure diet quality. J. Exp. Agric. Anim. Husb. 4: 71-79.
- _____, Judith Ball, McManus, W.R., Bush, I.G. (1966). Studies on the diet of the grazing animal. I. Seasonal changes in the diet of sheep grazing on pastures of different availability and composition. Aust. J. Agric. Res. 17, 543-56.

- Arnold, G.W., Dudzinski, M.L. (1967a). Studies on the diet of the grazing animal. II. The effect of physiological status in ewes and pasture availability on herbage intake. Aust. J. Agric. Res. 18: 349-359.
- _____, _____ (1967b). Studies on the diet of the grazing animal. III. The effect of pasture species and pasture structure on the herbage intake of sheep. Aust. J. Agric. Res. 18: 657-666.
- _____, Birrell, H.A. (1977). Food intake and grazing behaviour of sheep varying in body condition. Anim. Prod. 24: 343-353.
- Baile, C.A., Forbes, J.M. (1974). Control of feed intake and regulation of energy balance in ruminants. Physiological Reviews 54(1): 160 -
- Baker, R.D. (1975). Effect of sward characteristics on herbage intake under grazing - nutritive quality, species and amount. In 'Pasture utilization by the grazing animal'. Ed. J. Hodgson, D.K. Jackson. Occasional Symposium No. 8. Brit. Grassld. Soc. p. 87-93.
- Bartlett, C.O. (1958). A study of some deer and forest relationships in Rondeau Provincial Park. Ont. Dep. of Lands and Forest. Wildlife Series No. 7. 172p.
- Baumgardt, B.R., Taylor, M.W., Cason, J.L. (1962). Evaluation of forages in the laboratory. II. Simplified artificial rumen procedure for obtaining repeatable estimates of forage nutritive value. J. Dairy Sci. 45, 62-68.
- Bines, J.A. (1976). Factors influencing voluntary food intake in cattle. In 'Principles of cattle production'.

- Ed. Swan H, Broster, W.H. - Butterworths. Chapt. 14.
p. 287-305.
- Bines, J.A., Davey, A.W.F. (1970). Voluntary intake, digestion, rate of passage, amount of material in the alimentary tract and behaviour in cows receiving complete diets containing straw and concentrates in different proportions. *Brit. J. Nutr.* 24: 1013-1028.
- Blaser, R.E., Hammes, R.C. (Jnr.), Bryant, H.T., Hardison, W.A., Fontenot, J.P., Engel, R.W. (1960). The effect of selective grazing on animal output. *Proc. 8th International Grassld. Congr.* p. 601-
- Boswell, C.C. (1976). Comparisons of cattle grazing and sheep grazing. *Proc. N.Z. Grassld. Assoc.* 38: 56-65.
- Chacon, E., Stobbs, T.H., Haydock, K.P. (1977). Estimation of leaf and stem contents of oesophageal extrusa samples from cattle. *J. Aust. Inst. Agric. Sci.* 43: 73-5.
- _____, _____, Dale, M.B. (1978). Influence of sward characteristics on grazing behaviour and growth of hereford steers grazing tropical grass pastures. *Aust. J. Agric. Res.* 29(1): 89-102..
- Chamrad, A.D., Box, T.W. (1968). Food habits of white-tailed deer in South Texas. *J. Range Mgt.* 21: 158-164.
- Chenost, M., Grenet, E., Demarquilly, C., Jarrige, R. (1970). The use of the nylon bag technique for the study of forage digestion in the rumen and for predicting feed value. *Proc. XI. International Grassld. Congr. Surfers Paradise, Australia.* p. 697 -

- Clark, K.W., Mott, G.O. (1960). The dry matter digestion in vitro of forage crops. *Can. J. Plant Sci.* 40: 123-129.
- Cockayne, L. (1919). An economic investigation of the montane tussock grasslands. 2. Relative palatability for sheep of the various pasture plants. *N.Z. Jl. Agric.* 18: 321-331.
- Collett, R.H. (1961). Palatability of forage plants in North-west sheep pastures. *J. Dept. Agric. W.A.* 2: 733-736.
- Collins, D.P., O'Donovan, P.B. (1970). An evaluation of white clover in swards for calf feeding. *Occ. Sym. No. 6. Brit. Grassld. Soc.* p. 285-291.
- Cook, C.W. (1959). The effect of site on the palatability and nutritive content of seeded wheat grasses. *J. Range Mgt.* 12: 289-292.
- _____ (1964). Symposium on nutrition of forages and pastures : collecting forage samples representative of ingested material of grazing animals for nutritional studies. *J. Anim. Sci.* 23: 265 -
- _____, Blake, J.T., Call, J.W. (1963). Use of esophageal fistula cannulae for collecting forage samples from both sheep and cattle grazing in common. *J. Anim. Sci.* 22: 579-581.
- Cowlishaw, S.J., Alder, F.E. (1960). The grazing preferences of cattle and sheep. *J. Agric. Sci. Camb.* 54: 257-265.
- Crocker, B.H. (1959). A method of estimating botanical composition of the diet of sheep. *N.Z. J. Agric. Res.* 2: 72-85.

- Davies, D.A. (1975). Productivity of S.59 red fescue with and without S184 white clover under hill conditions. 2. Herbage measurements in relation to animal performance. *J. Agric. Sci. Camb.* 84: 273-280.
- Demarquilly, C., Jarrige, R. (1973). The comparative nutritive value of grasses and legumes. *Proc. 5th Gen. Meeting European Grassld. Fed. Vaxtodling* 28: 33 -
- Dudzinski, M.L., Arnold, G.W. (1973). Comparison of diets of sheep and cattle grazing together on sown pastures on the southern tablelands of New South Wales by principal component analysis. *Aust. J. Agric. Res.* 24: 899-912.
- Eadie, J. (1967). The nutrition of grazing hill sheep: improved utilization of hill pastures. In '4th Report Hill Farming Research Organisation'.
- Evans, R.A., Love, R.M. (1957). The step-point method of sampling—a practical tool in range research. *J. Range Mgt.* 10: 208-212.
- Free, J.C., Sims, P.L. Hansen, R.M. (1971). Methods of estimating dry-weight composition in diets of steers. *J. Anim. Sci.* 32: 1003-1007.
- Freer, M. (1960). The utilization of irrigated pastures by dairy cows. II. The effect of stocking rate. *J. Agric. Sci., Camb.* 54: 243-256.
- Galt, H.D., Ogden, P.R., Ehreneich, J.H., Taeurer, B., Martin, S.C. (1968). Estimating botanical composition of forage samples from fistulated steers by a microscope point method. *J. Range Mgt.* 21: 397-401.
- Glendenning, G.E. (1944). Some factors affecting cattle use of northern *Arizonia* pine-bunchgrass range. SW For. Range Exp. Sta. Res. Rep. 6.

- Green, J.O. (1949). Herbage sampling errors and grazing trials. *J. Brit. Grassld. Soc.* 4: 11-16.
- Greenhalgh, J.F.D., Reid, G.W., Aitken, J.N., Florence, E. (1966). The effects of grazing intensity on herbage consumption and animal production. 1. Short-term effects in strip-grazed dairy cows. *J. Agric. Sci. Camb.* 67: 13-23.
- _____, Reid, G.W. (1969). The effects of grazing intensity on herbage consumption and animal production. III. Dairy cows grazed at two intensities on clean or contaminated pasture. *J. Agric. Sci. Camb.* 72: 223 -
- Grimes, R.C., Watkin, B.R., May, P.F. (1965). The botanical and chemical analysis of herbage samples obtained from sheep fitted with oesophageal fistulae. *J. Brit. Grassld. Soc.* 20: 168-173.
- _____, _____, Gallagher, J.R. (1967). The growth of lambs grazing on perennial ryegrass, tall fescue, and cocksfoot, with and without white clover, as related to the botanical and chemical composition of the pasture and pattern of fermentation in the rumen. *J. Agric. Sci.* 68: 11-21.
- Hall, D.G., Hamilton, B.A. (1975). Estimation of the botanical composition of oesophageal extrusa samples. 2. A comparison of manual separation and a microscope point technique. *J. Brit. Grasslds. Soc.* 30: 273 -
- Hamilton, B.A., Hutchinson, K.J., Annis, P.C., Donnelly, J.B. (1973). Relationship between the diet selected by grazing sheep and the herbage on offer. *Aust. J. Agric. Res.* 24: 271-277.

- Hamilton, B.A., Hall, D.G. (1975). Estimation of the botanical composition of oesophageal extrusa samples. 1. A modified microscopic point technique. *J. Brit. Grassld. Soc.* 30: 229-235.
- Hancock, J. (1954). Studies of grazing behaviour in relation to grassland management. 1. Variations in grazing habits of dairy cattle. *J. Agric. Sci.* 44: 420-9.
- Harker, K.W., Torell, D.T., Van Dyne, G.M. (1964). Botanical examination of forage from oesophageal fistulas in cattle. *J. Anim. Sci.* 23: 465-469.
- Harkess, R.D. (1963). Studies in herbage digestibility. *J. Brit. Grassld. Soc.* 18: 62 -
- _____, de Battista, J., Dickson, I.A. (1972). A portable corral technique for measuring the effect of grazing intensity of yield, quality, and intake of herbage. *J. Brit. Grassld. Soc.* 27: 145-153.
- Heady, H.F. (1964a). Botanical composition of sheep and cattle diets on a mature annual range. *Hilgardia* 36: 465 -
- _____ (1964b). Palatability of herbage and animal preference. *J. Range Mgt.* 17: 76-82.
- _____, Torell, D.T. (1959). Forage preferences exhibited by sheep with oesophageal fistulas. *J. Range Mgt.* 12: 28-34.
- _____, Van Dyne, G.M. (1965). Prediction of weight composition from point samples on clipped herbage. *J. Range Mgt.* 18: 144-148.
- Hercus, Barbara H. (1960). Plant cuticle as an aid to determining the diet of grazing animals. *Proc. 8th Int. Grassld. Cong.* 443 -

- Hercus, J.M. (1961). What do sheep eat on tussock grassland? N.Z. J. Agric. 103: 73,75,77.
- _____ (1963). Botanical sampling as a means of identifying the components of sheep's diet in tussock grassland. N.Z. J. Agric. Res. 6: 83-9.
- Hodge, R.W., Doyle, J.J. (1967). Diet selected by lambs and yearling sheep grazing on annual and perennial pastures in Southern Victoria. Aust. J. Exp. Agric. Anim. Husb. 7: 141-143.
- Hodgson, J. (1969). The use of sheep fitted with oesophageal fistulae in grazing studies. J. Br. Grassld. Soc. 24: 325-332.
- _____ (1973). The effect of the grazing animal on herbage quality and utilization. In 'Quality of Herbage' Proc. 5th. General Meeting European Grassland Fed. p. 74-80.
- _____ (1975). The consumption of perennial ryegrass and red clover by grazing lambs. J. Brit. Grassld. Soc. 30: 307-313.
- _____ (1977). Factors limiting herbage intake by the grazing animal. In 'Proc. Int. Meeting on Animal Production from Temperate Grasslands. Irish Grassland and Animal Production Association, Dublin. p. 70-75.
- _____, Ollerenshaw, J.H. (1969). The frequency and severity of defoliation of individual tillers in set-stocked swards. J. Brit. Grassld. Soc. 24: 226 -
- _____, Rodriguez, J.M. (1970). The measurement of herbage intake in grazing studies. Annual Report Grassld. Res. Inst. Hurley p. 132-140.

- Hughes, J.G. (1975). What sheep eat on developed and undeveloped high country. *J. Tussock Grasslands and Mountain Lands Institute* 31: 20 -
- Hunt, L.A. (1965). Some implications of death and decay in pasture production. *J. Brit. Grassld. Society* 20: 27-31.
- Hunt, W.F. (1970). The influence of leaf death on the rate of accumulation of green herbage during pasture regrowth. *J. Appl. Ecology*. 7: 41-50.
- _____ (1971). Leaf death and decomposition during pasture regrowth. *N.Z. J. Agric. Res.* 14(1): 208-18.
- Hurd, R.M., Pond, F.W. (1958). Relative preferences and productivity of species on summer cattle ranges. Big Horn Mountains, Wyoming. *J. Range Mgt.* 11: 109 -
- Jackson, D.K. (1976). The influence of patterns of defoliation on sward morphology. In 'Pasture Utilization by the grazing animal'. Ed. J. Hodgson, D.K. Jackson. Occasional Sym. No. 8. *Brit. Grassld. Soc.* p. 51-60.
- Jarrige, R., Minson, D.J. (1964). Digestibilite' des constitunts du ray grass anglais S24 et du dactyle S37, plus specialement des constituants glucidiques. *Ann. Zootech* 13: 118-150.
- _____, Demarquilly, C., Dulphy, J.P. (1973). The voluntary intake of forages. Proc. 5th Gen. Meeting European Grassld. Fed. *Vaxtodling* 28: 98 -
- Jones, L.L.I. (1952). Measurement of palatability. Proc. 6th Int. Grassld Congr. p. 1348-1353.
- Joyce, J.P. (1970). Intensive beef and sheep production. *Proc. N.Z. Grassld. Assoc.* 32: 168-180.

- Keogh, R.G. (1973). Herbage growth, and the grazing pattern of sheep set-stocked, on a ryegrass-dominant, staggers-prone pasture during summer. N.Z. J. Exp. Ag. 1(1): 51-54.
- _____ (1975). Grazing behaviour of sheep during summer and autumn in relation to facial eczema. Proc. N.Z. Soc. An. Prod. 35: 198-203.
- Korte, C.J. (1973). A study of the selectivity of sheep grazing pastures. Unpubl. thesis B. Agr. Sc. Massey University.
- Krueger, W.C. (1972). Evaluating animal forage preference. J. Range Mgt. 25: 471-475.
- _____, Laycock, W.A., Price, D.A. (1974). Relationships of taste, smell, sight and touch to forage selection. J. Range Mgt. 27: 258-262.
- Lambourne, L.J. (1965). Some grassland problems in the United Kingdom and the Netherlands - estimation of intake and digestibility of grazed herbage. In 'Grasslands Rep. Inst. Hurley, Berks. Tech. Rep. No. 1. pp. 40. p. 11-12.
- _____, Reardon, T.F. (1962). Use of seasonal regressions in measuring feed intake of grazing animals. Nature, 196: 961 -
- Lancashire, J.A. (1971). Effect of white clover on the liveweight gain of calves. Irish J. Agric. Res. 10: 103-6.
- _____, Keogh, R.G. (1966). Some aspects of the behaviour of grazing sheep. Proc. N.Z. Soc. Anim. Prod. 26: 22-35.
- _____, Ulyatt, M.J. (1974). Liveweight gains by sheep grazing browntop and perennial ryegrass.

Proc. N.Z. Grassld. Assoc. 35(1): 110-117.

Langlands, J.P. (1965). Diurnal variation in the diet selected by free-grazing sheep. Nature, London 207: 666-667.

_____ (1966). Studies on the nutritive value of the diet selected by grazing sheep. I. Differences in composition between herbage consumed and material collected from oesophageal fistulae. Anim. Prod. 8: 253-259.

_____ (1967a). II. Some sources of error when sampling oesophageally fistulated sheep at pasture. Anim. Prod. 9: 167-175.

_____ (1968). The feed intake of grazing sheep differing in age, breed, previous nutrition and liveweight. J. Agric. Sci. Camb. 71: 167-172.

_____ (1969a). Studies on the nutritive value of the diet selected by grazing sheep. IV. Variation in the diet selected by sheep differing in age, breed, sex, strain and previous history. Anim. Prod. 11: 369-378.

_____ (1969b). V. Further studies of the relationship between digestibility estimated in vitro from oesophageal fistula samples and from faecal and dietary composition. Anim. Prod. 11: 379-387.

_____ (1974). VII. A note on hand plucking as a technique for estimating dietary composition. An. Prod. 19(2): 249-52.

_____ (1975). Techniques for estimating nutrient intake and its utilization by the grazing ruminant. In 'Digestion and Metabolism in the Ruminant'. Ed. McDonald, I.W. and Warner, A.C.I. p. 320-332.

Langlands, J.P., Bennett, I.L. (1973b). Stock intensity and pastoral production. II. Herbage intake of Merino sheep grazed at different stocking rates. J. Agric. Sci. Camb. 81: 205-209.

_____, Sanson, J. (1976). Factors affecting the nutritive value of the diet and the composition of rumen fluid of grazing sheep and cattle. Aust. J. Agric. Res. 27: 691-707.

_____, Holmes, C.R. (1978). The nutrition of ruminants grazing native and improved pastures. 1. Seasonal variation in the diet selected by grazing sheep and cattle. Aust. J. Agric. Res. 29: 863-874.

Laycock, W.A., Buchanan, H., Kruger, W.C. (1972). Three methods of determining diet, utilization and trampling damage on sheep ranges. J. Range Mgt. 25: 352-356.

Leaver, J.D. (1976). Utilization of grassland by dairy cows. In 'Principles of cattle production'. Ed. Swan, H., Broster, W.H. Butterworths publ. Chapt. 15. p. 307-327.

Leigh, J.H. (1966). Selection of diet by sheep grazing semi-arid pastures on the Riverine Plain. 1. A bladder saltbush (Atriplex vesicaria) - cotton bush (Kochia aphylla) community. Aust. J. Expt. Agric. Anim. Husb. 6: 460-467.

Levy, E.B. (1970). Grasslands of New Zealand 374p. A.R. Shearer, Govt. Printer, Wellington, N.Z.

_____, Madden, E.A. (1933). The point method of pasture analysis. N.Z. J. Agric. 46: 267-79.

Lynch, P.B. (1966). Conduct of Field Experiments. Bulletin No. 399. N.Z. Dept. Agric. 154p.

- Lynch, P.B., Mountier, N.S. (1954). Cutting techniques in grassland experiments. N.Z. J. Sci. Tech. 36(A): 375-385.
- McBride, G., Arnold, G.W., Alexander, G., Lynch, J.J. (1967). Ecological aspects of the behaviour of domestic animals. Proc. Ecol. Soc. Aust. 2: 133 -
- MacDiarmid, B.N., Watkin, B.R. (1971). The cattle dung patch. 1. Effect of dung patches on yield and botanical composition of surrounding and underlying pasture. J. Brit. Grassld. Soc. 26: 239-245.
- McDonald, I.W. (1968). The nutrition of grazing ruminants. Nutrition Abstracts and Reviews 38(2): 381-400.
- McIvor, P.J., Watkin, B.R. (1973). The pattern of defoliation of cocksfoot by grazing sheep. Proc. N.Z. Grassld. Assoc. 34(2): 225-35.
- McLeod, M.N., Minson, D.J. (1969). Sources of variation in the in vitro digestibility of tropical grasses. J. Brit. Grassld. Soc. 24: 244 -
- MacLusky, D.S. (1960). Some estimates of the areas of pastures fouled by the excreta of dairy cows. J. Brit. Grassld. Soc. 27: 48-54.
- McManus, W.R. (1962). Studies on the relationship of saliva to rumen functions of sheep on low feed intakes. Aust. J. Agric. Res. 13: 907-913.
- _____, Arnold, G.W., Hamilton, F.J. (1962). Improved techniques in oesophageal fistulation of sheep. Aust. Vet. J. 38: 275-281.
- Meyer, J.H., Hull, J.L., Weitkamp, W.H., Bonilla, S. (1965). Compensatory growth responses of fattening steers following various low energy intake regimes on hay or irrigated pasture. J. Anim. Sci. 24: 29-37.

- Milford, R. (1960). Nutritional value of subtropical pasture species under Australian conditions. Proc. 8th Int. Grassld. Congr. Reading 474 -
- Milton, W.E.J. (1933). The palatability of the self-establishing species contributing to different types of grassland. Empire J. Experimental Agriculture 1: 347 -
- _____ (1953). The palatability of herbage on undeveloped grasslands in west-central Wales. Emp. J. Exp. Agric. 21: 116-122.
- Minson, D.J., Raymond, W.F. (1958). Sources of error in the use of faecal index relationships. Experiments in Progress, Grassland Research Institute, Hurley 10: 92-96.
- _____, _____, Harris, C.E. (1960). The digestibility of grass species and varieties. Proc. 8th Int. Grassld. Congr. Reading p. 470-474.
- _____, Harris, C.E., Raymond, W.F., Milford, R. (1964). The digestibility and voluntary intake of S22 and H1 ryegrass, S170 tall fescue, S48 Timothy, S125 Meadow Fescue and Germinal Cocksfoot. J. Brit. Grasslands Soc. 19: 298-305.
- Monteath, M.A. (1970). Intensive meat and wool production in the higher rainfall areas of Otago and Southland. Proc. N.Z. Grassld Assoc. 32: 181-190.
- _____, Johnstone, P.D., Boswell, C.C. (1977). Effects of animals on pasture production. 1. Pasture productivity from beef cattle and sheep farmlets. N.Z. J. Agric. Res. 20: 23-30.

- Morris, R.M. (1970). The use of cutting treatments designed to simulate defoliation by sheep. *J. Br. Grassld. Soc.* 25: 198-206.
- Moule, G.R. (1965). Field Investigations with sheep, a manual of techniques. Melbourne 1966. Publ. Commonwealth S.I.R. Org. East Melbourne, Victoria, Australia.
- Osbourn, D.F., Thomson, D.J., Terry, R.A. (1966). The relationship between voluntary intake and digestibility of forage crops, using sheep. *Proc. 10th Int. Grassld. Congr.* p. 363-366.
- Peel, Lynette, J., Wilson, A.D. (1964). Some effects of anaesthesia, lateral recumbency, and diversion of saliva on the rumen function of sheep. *Aust. J. Agric. Res.* 15: 625 -
- Petrides, G.A. (1975). Principal foods versus preferred foods and their relation to stocking rate and range condition. *Biol. Conserv.* 7: 161-169.
- Phillips, J.D., Pfeiffer, R.K. (1958). An example of the relation between palatability of pastures and selective butter-cup control. *Proc. 4th Brit. Weed Control Conf.* p. 15-17.
- Pritchard, G.I., Folkins, L.P., Pidgeon, W.J. (1963). The in vitro digestibility of whole grasses and their parts at progressive stages of maturity. *Can. J. Plant Sci.* 43: 79-87.
- Rae, A.L., Brougham, R.W., Glenday, A.C., Butler, G.W. (1963). Pasture type in relation to liveweight gain, carcass composition, iodine nutrition and some rumen characteristics of sheep. 1. Liveweight growth of the sheep. *J. Ag. Sci. Cambridge* 61: 187-190.

- Rattray, P.V., Jagusch, K.T. (1978). Pasture allowances for the breeding ewe. N.Z. Soc. Anim. Prod. 38: 121 -
- Raymond, W.F. (1954). The use of faecal collection and chemical analysis in pasture studies. J. Brit. Grassld. Soc. 9: 61 -
- _____ (1969). 'The nutritive value of forage Crops' In 'Advances in Agronomy'. Ed. M.G. Brady, Academic Press, N.Y. p. 1-108.
- Robards, G.E., Wilson, A.D. (1967). The in vitro digestibility of oesophageal fistula samples after washing for botanical separation. Aust. J. Exp. Agric. Anim. Husb. 7: 22-24.
- Rodriguez, J.M., Hodgson, J. (1974). The influence of sward characteristics on the herbage intake of young grazing cattle in tropical and temperate climates. Proc. 12th Int. Grassl. Congr. Moscow III (1): 87-96.
- Roughan, P.G., Holland, R. (1977). Predicting in vivo digestibilities of herbages by exhaustive enzymic hydrolysis of cell walls. J. Sci. Food Agric. 28: 1057 -
- Round-Turner, N. (1972). The point analysis method for measuring pasture composition - a review. M.A.F. Internal Publication 3p.
- Rumball, P.J. (1966). A study of pasture pattern in relation to microtopography. Thesis M. Agr. Sc. Massey University.
- Scales, G.H., Streeter, C.L., Denham, A.H., Ward, G.M. (1974). A comparison of indirect methods of predicting in vivo digestibility of grazed forage. J. Anim. Sci. 38: 192-199.

- Scott, D., Maunsell, L.A. (1974). Diet and mineral nutrition of sheep on undeveloped and developed tussock grassland. 2. Vegetation composition and availability. N.Z. J. Agric. Res. 17: 177-189.
- Sears, P.D. (1951). The technique of pasture management. N.Z. J. Sci. and Tech. 33(A): 29 -
- Slater, Joana, Jones, R.J. (1971). Estimation of the diets selected by grazing animals from microscopic analysis of the faeces - a warning. J. Aust. Inst. Agric. Sci. 37: 238-240.
- Smeatham, M.L. (1973). 'Grazing management' In 'Pasture and Pasture Plants'. Ed. R.H.M. Langer Chapt. 7. p. 180-228.
- Snedecor, G.W., Cochran, W.G. (1968). 'Statistical methods' 6th Edition. Iowa State University Press, Ames, Iowa, U.S.A.
- Stevens, E.J. (1977). The botanical analysis of sheep diet; and comparison of three methods of sheep diet determination and the field application of faecal cuticle analysis. Unpubl. Thesis M. Agr. Sci. University of Canterbury.
- Stobbs, T.H. (1969). The effect of grazing management upon pasture productivity in Uganda. IV. Selective grazing. Trop. Agric. Trin. 46: 303-309.
- _____ (1973a). The effect of plant structure on the intake of tropical pastures. 1. Variation in the bite size of grazing cattle. Aust. J. Agric. Res. 24: 809-819.
- _____ (1973b). II. Differences in sward structure, nutritive value, and bite size of the animals grazing setaria anceps and chloris gayana at various stages of

- growth. Aust. J. Agric. Res. 24: 821-829.
- Stobbs, T.H. (1975a). Factors limiting the nutritional value of grazed tropical pastures for beef and milk production. Tropical Grasslands 9(2): 141-150.
- _____ (1975b). The effect of plant structure on the intake of tropical pasture. III. Influence of Fertilizer nitrogen on the size of bite harvested by Jersey cows grazing Setaria anceps c.v. Kazungula swards. Aust. J. Agric. Res. 26: 997-1007.
- Streeter, C.L. (1970). A review of techniques used to estimate the in vivo digestibility of grazed forage. J. Anim. Sci. 29(5): 757 -
- Suckling, F.E.T. (1964). Hill Pasture behaviour under different stocking rates. Proc. N.Z. Grassld. Assoc. p. 137-152.
- _____ (1976). Pasture management trials on unploughable hill country at Te Awa. N.Z. J. Exp. Agric. 3: 351-436.
- Taylor, J.C., Deriaz, R.E. (1963). The use of rumen-fistulated steers in the direct determination of nutritive value of ingested herbage in grazing experiments. J. Brit. Grassld. Soc. 18: 29-38.
- Terry, R.A., Mundell, D.C., Osbourn, D.F. (1978). Comparison of two in vitro procedures using rumen liquor pepsin or pepsin-cellulase for prediction of forage digestibility. J. Brit. Grassld. Soc. 33: 13-18.
- _____, Tilley, J.M.A. (1964). The digestibility of the leaves and stems of perennial ryegrass, cocksfoot, timothy, tall fescue, lucerne and sainfoin, as measured by an in vitro procedure. J. Brit. Grassld. Soc. 19: 363-372.

- Theurer, C.B. (1970). Determination of botanical and chemical compositions of the grazing animals diet. Proc. Nat. Conf. on Forage Quality, Evaluation and Utilization. Barnes Chapt. J1-J17.
- Thornton, R.F., Minson, D.J. (1973). The relationship between apparent retention time in the rumen, voluntary intake, and apparent digestibility of legume and grass diets in sheep. Aust. J. Agric. Res. 24: 889-898.
- Tilley, J.M.A., Terry, R.A. (1963). A two-stage technique for the in vitro digestion of forage crops. J. Brit. Grassld. Soc. 18: 104-111.
- Torell, D.T. (1954). An esophageal fistula for animal nutrition studies. J. Animal Sic. 13: 878 -
- Troelsen, J.E., Henel, D.J. (1966). Ruminant digestion in vitro as affected by inoculum donor, collection day and fermentation time. Can. J. Anim. Sci. 46: 149-156.
- Ulyatt, M.J. (1969). Progress in defining the differences in nutritive value to sheep of perennial ryegrass, short-rotation ryegrass and white clover. Proc. N.Z. Soc. An. Prod. 29: 114-123.
- _____ (1970). Factors contributing to differences in the quality of short rotation ryegrass, perennial ryegrass and white clover. Proc. XI Int. Grassld. Congr. 709 -
- _____ (1970a). Evaluation of pasture quality under New Zealand conditions. Proc. N.Z. Grassld. Assoc. 32: 61-68.
- _____ (1971). Studies on the causes of the differences in pasture quality between perennial

- ryegrass, short-rotation ryegrass, and white clover. N.Z. J. Agric. Res. 14(2): 352-367.
- Ulyatt, M.J. (1973). The feeding value of herbage In. 'Chemistry and Biochemistry of Herbage'. Ed. G.W. Butler, R.W. Bailey. Academic press London and New York; Vol III. Chapter 31, p. 131-178.
- _____, MacRae, J.C. (1971). The sites of digestion of fresh pasture species in the gastro-intestinal tracts of sheep. Proc. N.Z. Soc. Anim. Prod. 31: 74-81.
- _____, Barclay, P.C., Lancashire, J.A., Armstrong, C.S.M. (1974). The feeding value to sheep of 'Grasslands Tama' Westerwolds ryegrass, 'Grasslands Paroa' Italian ryegrass, and 'Grasslands Ruanui' perennial ryegrass under rotational grazing management. N.Z. J. Exp. Agric. 2: 231-6.
- _____, Lancashire, J.A., Jones, W.T. (1977). The nutritive value of legumes. Proc. N.Z. Grassld. Assoc. 38(1): 107-118.
- _____, MacRae, J.C. (1971). The sites of digestion of fresh pasture species in the gastro-intestinal tracts of sheep. Proc. N.Z. Soc. Anim. Prod. 31: 74-81.
- Utley, P.R., Bradley, N.W., Boling, J.A. (1970). Effect of restricted water intake on feed intake, nutrient digestibility and nitrogen metabolism in steers. J. Anim. Sci. 31: 130-135.
- Van Dyne, G.M., Vogel, W.G., Fisser, H.G. (1963). Influence of small plot size and shape on range herbage production estimates. Ecology 44: 746-759.

- Van Dyne, G.M., Torell, D.T. (1964). Development and use of the oesophageal fistula - a review. *J. Range Mgt.* 17: 7-19.
- _____, Heady, H.F. (1965). Botanical composition of sheep and cattle diets on a mature annual range. *Hilgardia* 36: 465-492.
- Weir, W.C., Torell, D.T. (1959). Selective grazing by sheep as shown by a comparison of the chemical composition of range and pasture forage obtained by hand-clipping and that collected by oesophageal-fistulated sheep. *J. Anim. Sci.* 18: 641-649.
- Wheeler, J.L., Reardon, T.F., Lambourne, L.J. (1963). The effect of pasture availability and shearing stress on herbage intake of grazing sheep. *Aust. J. Agr. Res.* 14: 364 -
- Wilson, A.D., Weir, W.C., Torell, D.T. (1971). Comparison of methods of estimating the digestibility of range forage and browse. *J. Anim. Sci.* 32(5): 1046-1050.
- Wilson, T.N., Osbourn, D.F. (1960). Compensatory growth after under-nutrition in mammals and birds. *Biol. Rev.* 50: 324 -

Addenda

- Brougham, R.W. (1977). Maximising animal production from temperate grassland. *Proc. Int. Meeting Anim. Prod. from temperate grassland, Dublin 1977. Irish Grassld. and Animal Prod. Assoc.* p. 140-146.
- Mulholland, J.G., Coombe, J.B., McManus, W.R. (1977). Diet selection and intake by sheep and cattle grazing together on stubbles of wheat, oats or barley. *Aust. J. Exp. Agric. An. Husb.* 17: 224-229.

Newman, D.M.R. (1974). The universal application of the two stage in vitro technique for pasture quality evaluation. Proc. XII Int. Grassld. Congr. Vol III(1) 326-334.