

Copyright is owned by the Author of the thesis. Permission is given for a copy to be downloaded by an individual for the purpose of research and private study only. The thesis may not be reproduced elsewhere without the permission of the Author.



Charlotte Bowie © 2010

A written component completed in partial fulfillment of the requirements for the degree of Masters of Design at Massey University, College of Creative Arts, Wellington, New Zealand.

Approximate word count: 13,114

Abstract

Atelierworkshop is an innovative Wellington based architectural practice that has advanced into the area of off- site manufacture of container-based housing solutions. Their product, the Port-a-Bach (PAB) is moving into its second generation (*PAB Gen-2*). This product development initiative has resulted in a range of projects that have been undertaken to improve off-the-grid energy systems, water supply and storage, packaging, transportation and cost reduction.

This particular project documents the design and development of an energy management and supply accessory product, called the *Bach Pack*. The *Bach Pack* seeks to create a viable product energy system solution, at reduced cost and environmental impact (compared with existing solutions) and to achieve this through the development of the usability aspects and features of the product system. The focus is on developing a quality experience for the end user with regards to the attachment and deployment of the components that make up the *Bach Pack* product. This accessory and modular product solution enables the *PAB Gen-2* to be self-sufficient with regard to electrical energy and water supply, and can be specified at point of sale or added later if required. This document focuses explicitly on the design and development of the solar array segment of the *Bach Pack*.

Acknowledgements

This project has been undertaken in collaboration with Atelierworkshop, Massey University and Grow Wellington/Technology NZ.

I would like to thank Cecile Bonnifait and William Giesen from Atelierworkshop for allowing me the opportunity to work alongside them in the development of such an exciting product venture.

Funding for this project was gained through Technology NZ, Technology for Industry Fellowships scheme (TIF).

There have been a number of people whom I would like to acknowledge who have supported and assisted me with my research project. Of notable mention are my supervisors, Rodney Adank and Lyn Garrett who provided me with valuable feedback and guidance throughout my project.

I would also like to thank my family, friends and fellow post-graduate students for their ongoing encouragement.

Contents Page

Chapter One: Introduction to the Bach Pack Project

1.0	Project Background.....	2
1.1	Port-a-Bach Product Development.....	3
1.2	Self-Sufficient Energy & Water Products.....	4
1.3	Project Aim & Objectives.....	5
1.4	Project Constraints.....	6

Chapter Two: Research Overview

2.0	Research Approach.....	7
2.1	Research Methods.....	8

Chapter Three: Designing Experience

3.0	Hierarchy of Consumer Needs.....	12
3.1	Perceptual Product Experience Framework.....	13
3.2	The Four Pleasures.....	14

Chapter Four: Contemporary Architecture & the Future of Self-Sufficiency

4.0	Future of Architecture.....	15
4.1	The Bach.....	17
4.2	Prefabricated & Portable Architecture.....	19
4.3	Case Study: Micro-Compact Home.....	20
4.4	Shipping Containers & Container Architecture.....	22
4.5	Case Study: Container House.....	23
4.6	Renewable Energy.....	25
4.7	Case Study: Eco-Nomad.....	26
4.8	Living Off-the-grid.....	28
4.9	Case Study: Emergency Response Studio.....	29

4.10	Case Study: The Yacht.....	31
4.11	Case Study Analysis.....	33
4.12	Existing Solar Arrays.....	36
4.13	Experience & Forecast Appraisal.....	39

Chapter Five: Results & Discussion of Solar System Research

5.0	Research for Design Overview.....	41
5.1	Appliance Analysis.....	42
5.2	Load Analysis.....	44
5.3	Site Visits & Semi-Structured Interviews.....	48
5.4	Solar System Research Conclusion.....	52

Chapter Six: Solar Array Design Criteria

6.0	Design Criteria Overview.....	53
6.1	Performance Design Criteria.....	54
6.2	Experience Design Criteria.....	56

Chapter Seven: Solar Array Creative Investigation

7.0	Research through Design: Overview.....	58
7.1	Ideation & Concept Sketching.....	58
7.2	Scale Model & Concept Development.....	60
7.3	Concept Development & Storyboarding.....	64
7.4	Iterative Concept Development.....	67
7.4.1	Iterative Development: Base Connection.....	67
7.4.2	Iterative Development: Mast & Solar Array Frame.....	74
7.5	User Testing.....	81
7.6	Computer Aided Design Modelling.....	85

Chapter Eight: The Bach Pack: Final Design

8.0	Bach Pack: Independent Energy Solution.....	88
8.1	Design Evaluation.....	100
8.2	Provisional Patent.....	107
8.3	Conclusion.....	108
8.4	Further Research.....	109

Chapter Nine: Reference List, Figure & Table Index

9.0	Reference List.....	110
9.1	Figure Index.....	114
9.2	Table Index.....	120

Chapter Ten: Glossary

10.0	Glossary.....	124
------	---------------	-----

Chapter Eleven: Appendix

11.0	Appendix.....	125
------	---------------	-----

List of Figures (for details see section 9.1)

Figure 1.	<i>Port-a-Bach exterior</i>	2	Figure 26.	<i>Solar array level of design against cost</i>	38
Figure 2.	<i>Port-a-Bach longitudinal section</i>	2	Figure 27.	<i>Solar array frames: materials and method of attachment</i>	39
Figure 3.	<i>Port-a-Bach interior</i>	3	Figure 28.	<i>Testing configurations for the generator and batteries using a scale model</i>	45
Figure 4.	<i>Port-a-Bach plan</i>	3	Figure 29.	<i>Off-the-grid system diagram</i>	48
Figure 5.	<i>Design objectives and activities</i>	5	Figure 30.	<i>Solar arrays encountered on site visits</i>	49
Figure 6.	<i>Research approach</i>	7	Figure 31.	<i>Site visit system component configuration examples</i>	50
Figure 7.	<i>Research modes</i>	8	Figure 32.	<i>Early conceptual investigation</i>	59
Figure 8.	<i>Sequence of research methods</i>	8	Figure 33.	<i>Storyboard of solar array 'Winch' concept</i>	60
Figure 9.	<i>Hierarchy of human and consumer needs</i>	12	Figure 34.	<i>Solar panel location concepts</i>	60
Figure 10.	<i>Perceptual product experience framework</i>	13	Figure 35.	<i>Rivnut rooftop fastening investigation</i>	62
Figure 11.	<i>Basic model of product emotions</i>	14	Figure 36.	<i>Concept storyboard</i>	64
Figure 12.	<i>Early examples of kiwi baches</i>	17	Figure 37.	<i>Raise the array: solar mast concept</i>	65
Figure 13.	<i>Vintage portable architecture vs contemporary portable, prefabricated architecture</i>	19	Figure 38.	<i>Using the perceptual product experience framework for Bach Pack design considerations</i>	66
Figure 14.	<i>Micro-compact home</i>	20	Figure 39.	<i>Container corner castings</i>	67
Figure 15.	<i>Redundant shipping containers</i>	22	Figure 40.	<i>Truck connection for shipping containers</i>	68
Figure 16.	<i>Container house</i>	23	Figure 41.	<i>Fastener analysis</i>	68
Figure 17.	<i>Annual energy outlook 2010</i>	25	Figure 42.	<i>Base connection ideation sketches</i>	69
Figure 18.	<i>Eco-Nomad</i>	26	Figure 43.	<i>Prototyping base connection concepts</i>	72
Figure 19.	<i>Contemporary biomimicry</i>	28	Figure 44.	<i>Base connection prototype development</i>	73
Figure 20.	<i>Emergency Response studio</i>	30	Figure 45.	<i>Methods of raising and lowering sails and flags</i>	76
Figure 21.	<i>Living off-the-grid on a yacht</i>	32	Figure 46.	<i>Collapsible clothesline</i>	76
Figure 22.	<i>User interaction against on and off-the-grid dwellings</i>	35	Figure 47.	<i>Mechanical hoist</i>	77
Figure 23.	<i>End user experience against type of design used in off-the-grid dwellings</i>	35	Figure 48.	<i>Bevel pinion mechanisms</i>	77
Figure 24.	<i>Solar panels integrated into residential properties</i>	36	Figure 49.	<i>Iterative investigation cam-lock concept</i>	78
Figure 25.	<i>Stand alone solar array frames</i>	36	Figure 50.	<i>Iterative investigation dog-leg concept</i>	79

Figure 51.	<i>Iterations of successful mechanisms.....</i>	80
Figure 52.	<i>User testing of base connection.....</i>	82
Figure 53.	<i>CAD development of base connection.....</i>	85
Figure 54.	<i>CAD development of base connection.....</i>	86
Figure 55.	<i>CAD development of array frame.....</i>	87
Figure 56.	<i>Bach Pack assembled on the Port-a-Bach Generation 2.....</i>	89
Figure 57.	<i>The Bach Pack final design front view.....</i>	90
Figure 58.	<i>The Bach Pack final design rear view.....</i>	91
Figure 59.	<i>The Bach Pack final design rear details.....</i>	92
Figure 60.	<i>Summary of design criteria evaluation for the Bach Pack.....</i>	98

List of Tables (for details see section 9.2)

Table 1.	<i>Project constraints and consequences.....</i>	6
Table 2.	<i>Research for design methods – Part one.....</i>	9
Table 3.	<i>Research for design methods – Part two</i>	10
Table 4.	<i>Research ‘through’ design methods – Part one.....</i>	11
Table 5.	<i>Case study analysis.....</i>	34
Table 6.	<i>Review of existing solar arrays.....</i>	37
Table 7.	<i>Bach Pack forecast appraisal.....</i>	40
Table 8.	<i>Appliance specifications.....</i>	43
Table 9.	<i>Electrical system components.....</i>	46
Table 10.	<i>Energy system overview.....</i>	47
Table 11.	<i>Performance design criteria – Part one.....</i>	54
Table 12.	<i>Performance design criteria – Part two.....</i>	55
Table 13.	<i>Experience design criteria – Part one.....</i>	56
Table 14.	<i>Experience design criteria – Part two.....</i>	57
Table 15.	<i>Solar panel location matrix.....</i>	61
Table 16.	<i>Solar panel array location pro’s vs con’s.....</i>	63
Table 17.	<i>Base connection concept scoring matrix – Part one.....</i>	70
Table 18.	<i>Base connection concept scoring matrix – Part two.....</i>	71
Table 19.	<i>Relationship between the Bach Pack and the four pleasures.....</i>	84
Table 20.	<i>Design evaluation of solar array performance criteria – Part one.....</i>	94
Table 21.	<i>Design evaluation of solar array performance criteria – Part two.....</i>	95
Table 22.	<i>Design evaluation of solar array experience criteria – Part one.....</i>	96
Table 23.	<i>Design evaluation of solar array experience criteria – Part two.....</i>	97

Reading Guide

Chapter One: **Introduction to the Bach Pack Project**

The existing product and its state of development is presented. Project aims and objectives are summarised and project constraints are covered.

Chapter Two: **Research Overview**

The research approach and research methods employed throughout the project are outlined.

Chapter Three: **Designing Experience**

Several frameworks that have been utilised throughout the project are reviewed.

Chapter Four: **Contemporary Architecture & the Future of Self-Sufficiency**

This chapter focuses on collating background research for the project. It notes a range of relevant fields, including existing case studies in order to establish the context of the project as well as beginning to develop design criteria considerations.

Chapter Five: **Results & Discussion of Solar System Research**

Results of research methods used *for* design are reviewed and discussed, providing critical results to inform the creative investigation.

Chapter Six: **Solar Array Design Criteria**

Performance and experience design criteria are outlined based on research findings.

Chapter Seven: **Solar Array Creative Investigation**

This chapter investigates and discusses research *through* design methods used to develop the solar array concept within the realms of the design criteria outlined.

Chapter Eight: **The Bach Pack: Final Design**

This final design of the Bach Pack is presented in detail. Evaluation of the concept is discussed with regards to the fulfillment of the design criteria.

Chapter Nine: **Reference List, Figure & Table Index**

This chapter notes sources used throughout the project from both the text and figures.

Chapter Ten: **Glossary**

A list of definitions and abbreviations are listed.

Chapter Eleven: **Appendix**

The appendix includes additional research from the project.

Personal Introduction

My contact with Atelierworkshop resulted from my interest in their (PAB) product. I was particularly drawn to its hybrid nature - an architectural product with an industrial design and manufacturing focus. My introduction to sustainable architecture began whilst studying a paper at Victoria University (which I subsequently tutored). Additionally I assisted with building an off-the-grid home in the Queen Charlotte Sounds, Marlborough in 2008.

Working with Atelierworkshop in this area of design development was exciting. The consequence of dealing with a "live project" is that the expectations and priorities are adjusted throughout the design process through teamwork and discussion. Negotiating these changes and keeping focused on my main aim and objectives for the project was challenging but in doing so I have gained a great deal of knowledge and understanding of the complexity of systems that lie within a product's structure and am keen to pursue this area of design further in future.

Chapter One Introduction to the Bach Pack Project

1.0 Project Background

The PAB is a form of micro architecture that utilises a twenty-foot shipping container for its exterior shell and capitalises on the portability that the container provides for transportation. The unit provides an immediate, flexible housing solution.

The interior allows space for a kitchen, double bed, bathroom and storage that are all integrated within the rear wall. The living space is expanded by unfolding the front face of the container that adapts as a deck, in effect doubling the floor area to 29m². Canvas awnings have been designed to link the indoor and outdoor spaces and to provide shelter from the elements.

Architects Cecile Bonifait and William Giesen from Atelierworkshop describe the concept of the PAB as, “a plug and play device. You can arrive at the bach, plug into the services, unfold the deck and relax within five minutes” (Giesen, personal communication, March 3, 2008).

Their aim in undertaking this micro architectural project was to create a high quality, environmentally considerate, prefabricated housing solution for less than NZ\$100,000.

The first PAB was designed to connect to municipal services including water and electricity. The PAB Gen-2 seeks to extend the portability of this off-site, manufactured living solution by being able to operate off-the-grid and being able to collect and store water.

In the context of this project, *PAB Gen-2* indicates the inclusion of the *Bach Pack* solar array product and where necessary is isolated as simply, the *Bach Pack*.



Figure 1. *Port-a-Bach* exterior (Bowie, 2009).

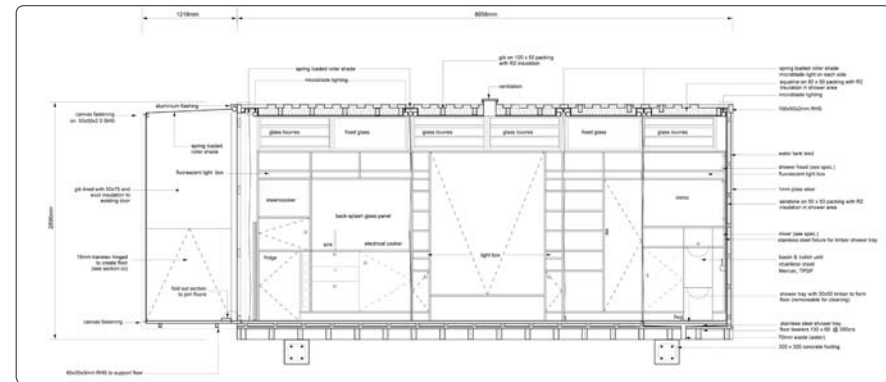

Figure 2. *Port-a-Bach* longitudinal section (Atelierworkshop, 2005).



Figure 3. Port-a-Bach interior (Bowie, 2009).

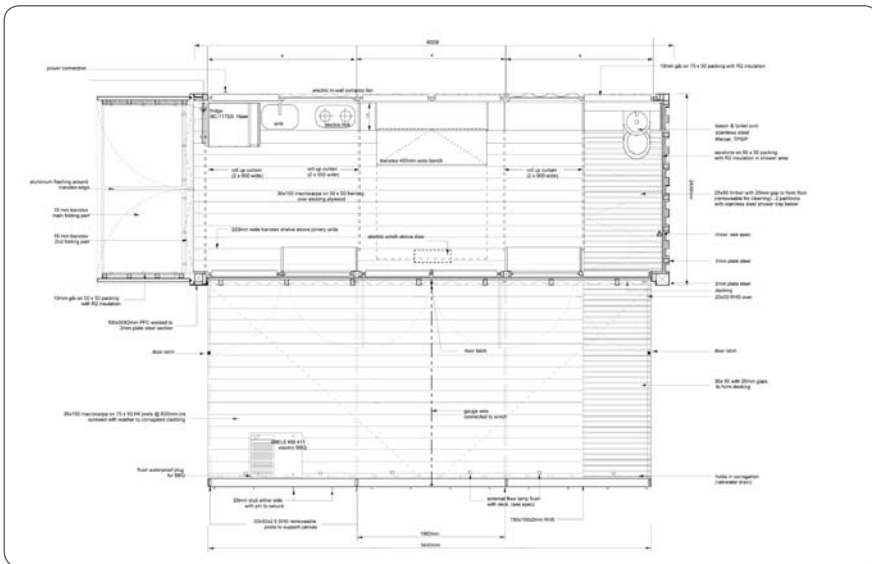

Figure 4. Port-a-Bach plan (Atelierworkshop, 2005).

1.1 Port-a-bach Product Development

Experience with the original product highlighted areas for further development. These areas centered on the development of more 'consumer product' type features through specification at point of purchase. These product development initiatives were identified and resulted in a prioritised list:

- 1) Self-sufficient energy and water enabling the PAB to be situated in remote locations without reliance on municipal services.
- 2) Modular furniture providing a more customisable product.
- 3) Modular features to enable multiple PAB units to work collectively.
- 4) Modular accessories allowing the PAB to move comfortably from sub-tropical to alpine temperature.

This particular project undertook to address 1; and resulted in the development of the *Bach Pack*.

Off-site manufacturing and prefabrication requires design development that addresses the specification and manufacture of system components and subsystems. This is an area where industrial design has traditionally contributed to enhance design in a manner than enhances the end user experience. Woudhuysen & Abley (2004, p.8) state that:

“Product designers could bring new skills to architecture, which suffers a disconnection with componentry, brackets and fixings that characterise structural engineering. Traditionally product designers are good at all that”.

This study seeks to bridge a gap between architecture and industrial design. To assist in this regard, the researcher has been immersed in the company which has aided

the communication and relationship between the two disciplines. The strategy was to assist the company by moving them towards a position whereby their product's design position shifted from standard architectural practice to a hybrid architectural-industrial design approach to manufacturing and design.

1.2 Self-sufficient Energy & Water Products

Early investigation into the water harvesting market proved that high quality solutions already existed and that specification of these existing components for the *PAB Gen-2* water harvesting and storage would suitably meet the objective outlined.

The clients communicated their interest in utilising solar energy as the primary source of energy for the *PAB Gen-2*. Solar energy is known to be an effective, reliable and widely used resource however when exploring the market for solar arrays, initial research presented few commercial products and provided evidence to support a need for a well-designed, solar array product that could be assembled by end users. Hence, this Masters project is based on the design and development of the solar array for the *PAB Gen-2*.

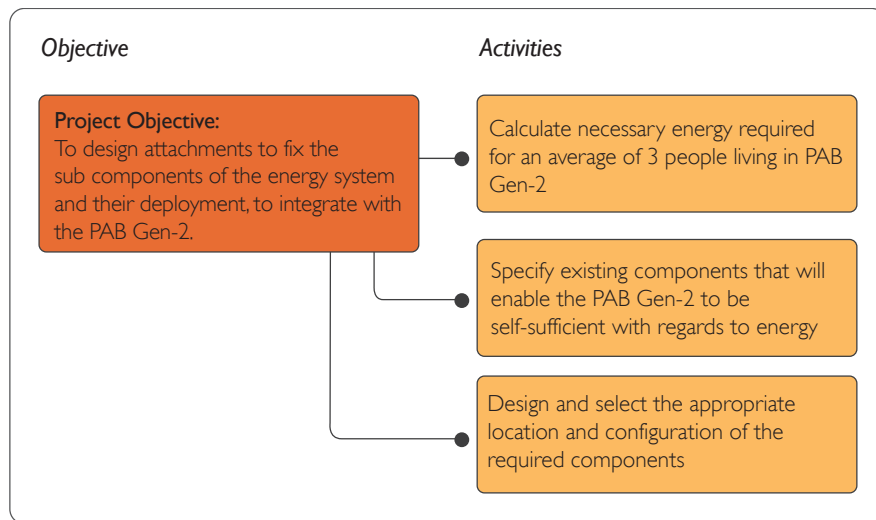

Figure 5. Design objectives and activities (Bowie, 2009).

1.3 Project Aim & Objectives

The aim of the project is to develop an energy management and supply product using existing technologies, which can be assembled by the end user and enables the *PAB Gen-2* to be off-the-grid. This product will be referred to as the *Bach Pack*. The *Bach Pack* product should raise levels of person/product experience (beyond function and usability) in relation to its design and deployment.

The 'end user' refers to the *PAB Gen-2* homeowner, who carries basic practical skills and will be required to assemble the *Bach Pack*.

The main objective was outlined to achieve this aim:

- To design attachments to fix the sub components of the energy system and their deployment to integrate with the *PAB Gen-2*.

Several activities were required in order to achieve each objective (Figure 5). These activities focused on the performance capabilities of the product and were used as a platform enabling the design and consideration of experience for the overall objective. This is explained further in Chapter 3.0.

1.4 Project Constraints

This project was constrained by the use of an existing product (shipping container), its physical characteristics and transportation system that are central to the value provided by the *PAB Gen-2*. These constraints are noted in *Table 1*.

Further areas of consideration include:

Cost: The design should consider cost, whilst maximising the creative capacity of the *Bach Pack*.

Manufacturing: The client wishes to manufacture all future versions of the *PAB* within New Zealand.

Time: The *PAB Gen-2* is expected to be commercialised within the next 18 months, therefore requiring the specification of reliable, proven technologies.

Energy requirements will vary worldwide due to locality. This project uses New Zealand as a primary platform to develop from.

<i>Constraint</i>	<i>Consequence</i>
Shipping container cannot be shipped if any part is protruding from the existing structure.	Independent energy system must be fully assembled on site without requiring protruding connections to the container.
The <i>Bach Pack</i> must be interdependent and integrate with the container both for attachment and storage of components.	The existing container structure should be exploited with regards to the assembly of the <i>Bach Pack</i> and the parts required considered for storage and transportation.
The <i>Bach Pack</i> should be designed for assembly by the <i>PAB Gen-2</i> end users.	Installation of the <i>Bach Pack</i> should require no more than two adults with basic practical skills. Existing technologies and familiar mechanisms should be utilised requiring as few parts as possible.
The <i>PAB Gen-2</i> should be designed as a universal product. Consideration of locations and their relationship to the sun will vary.	Any solar components must have the ability to adjust or rotate in order to gain maximum sunlight.

Table 1. *Project constraints and consequences* (Bowie, 2009).

Chapter Two Research Overview

2.0 Research Approach

This section focuses on discussing the research methods employed throughout this project. *Figure 6* illustrates the research phases undertaken and shows the focus on performance and experience that underpins the product development. The intention of the initial phase of background research was to ground the researcher in the subject area and to contribute to the development of criteria for design.

The secondary phase involved the researcher undertaking an iterative creative investigation to inform and meet the research objective whilst complying with the prescribed design criteria. The evaluation phase is discussed in *section 8.1*.

To achieve the project aim, the main objective was split into a series of activities to assist in achieving the project aim. Two dominant categories of research were employed to assist throughout the project and are outlined below:

- **Research for design:** This is research intended to provide information and data as a means of enabling the designing in the sense of improving the processes or outcomes (Downton, 2003). This phase of design research extends throughout the project and provides the initial groundwork for creative work.
- **Research through design:** This uses investigation through creative design practice to explore, test and refine the design in order to achieve the objective.

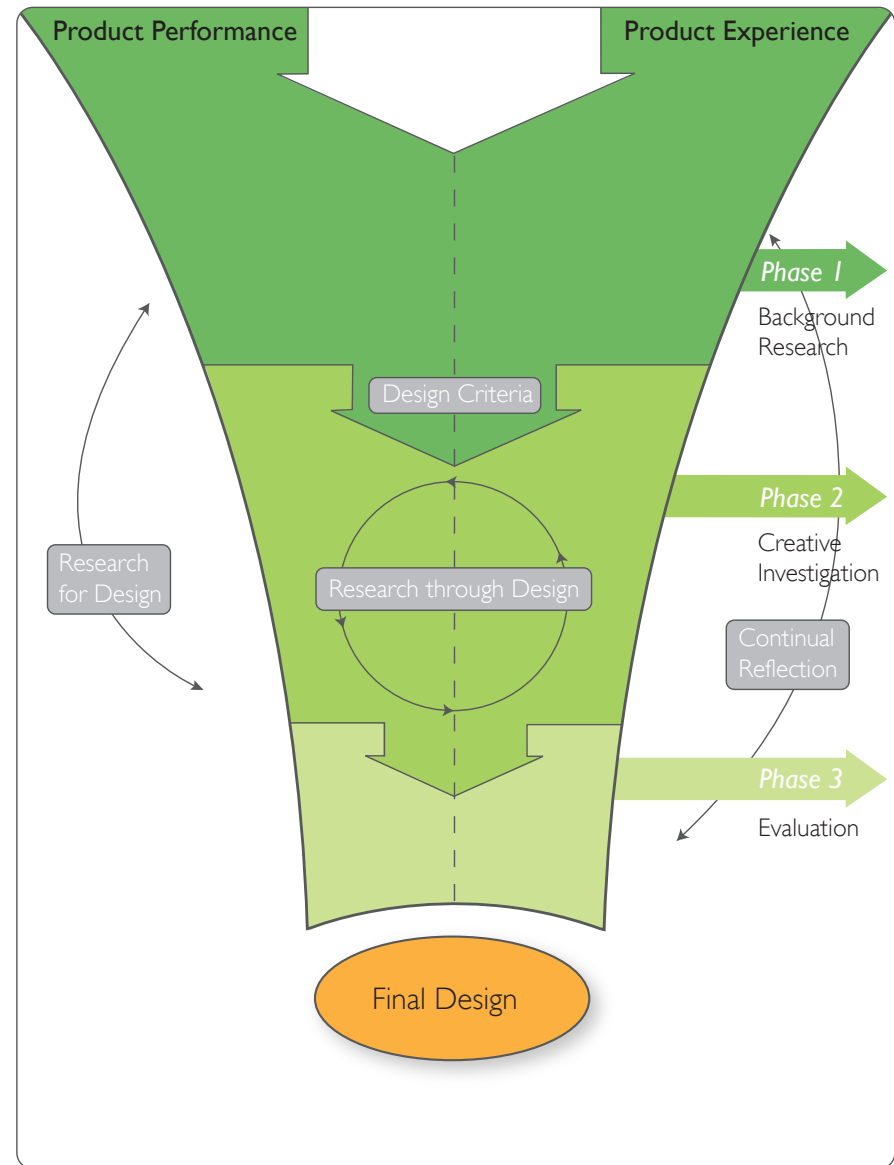

Figure 6. *Research approach* (Bowie, 2009).

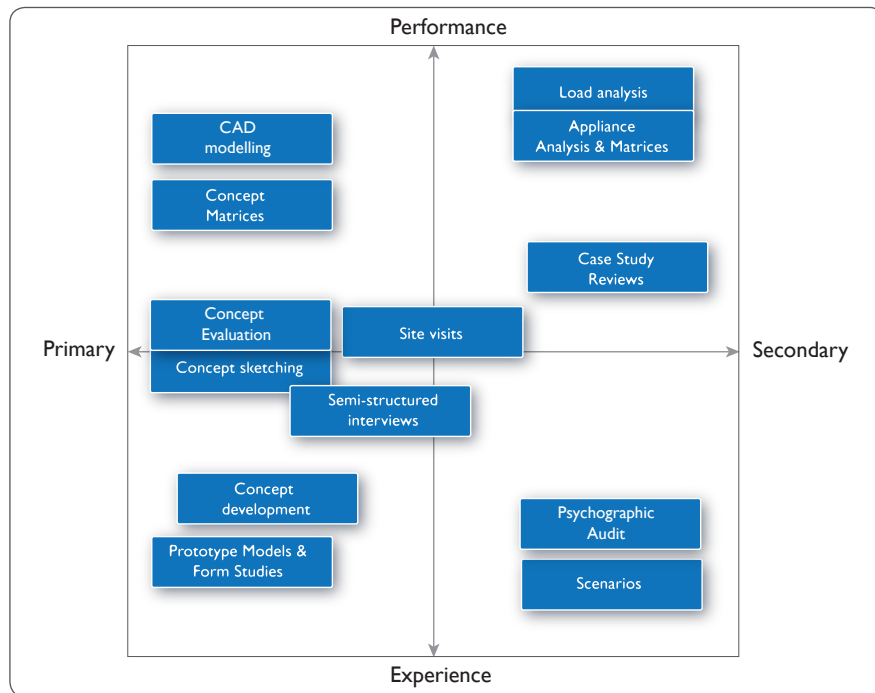

Figure 7. Research modes (Bowie, 2009).

2.1 Research Methods

Appropriate research methods were selected based on their relevance to the research being undertaken. As Figure 7 shows, selected methods were utilised to consider both the performance aspects of the design of the *Bach Pack* as well as the experience.

The secondary research methods were undertaken in the early phase of background context research. Primary research methods took place during the latter phases in the investigation as can be seen in Figure 8.

Methods were selected based on the expected outcome they could deliver. For example, a review of existing solar systems was required prior to embarking on a design for the *PAB Gen-2*. For this reason, site visits were considered a vital research method as the outcome meant a first hand account with end users of a variety of systems. These were able to highlight design issues and explain thoroughly their end user interaction, (as explained further in Tables 2-4).

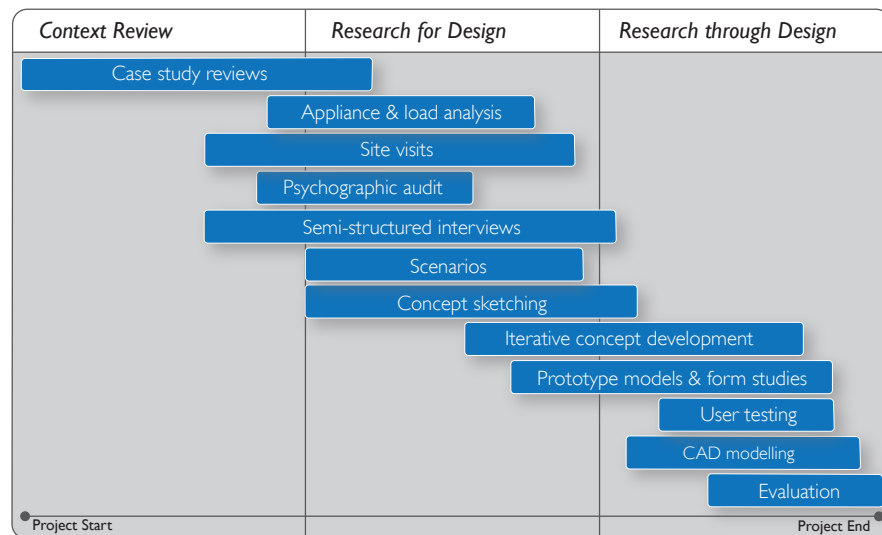

Figure 8. Sequence of research methods (Bowie, 2009).

<i>Method (Results)</i>	<i>Method Aim</i>	<i>Method Objective</i>	<i>Advantages of use</i>	<i>Disadvantages of use</i>	<i>Minimisation of potential issues</i>	<i>Method Implementation</i>
<p>Case Studies</p> <p><i>Results:</i> Section 4.9</p>	An overview of current relevant sources.	Additional design criteria.	Global insight of useful examples. Provision of existing examples, reviews and design issues noted.	Research can be subjective and limited to current market which differs from PAB Gen-2.	Explore wide range of examples.	Dominant topic areas were reviewed using online database searches. Areas included; portable, pre-fabricated, sustainable and container architecture, off-the-grid and renewable technology products.
<p>Appliance analysis & matrices (Pugh, 1990)</p> <p><i>Results:</i> Section 5.1</p>	To review a range of products and rank them according to weighted criteria set.	Selection of most appropriate appliances for PAB Gen-2. Specification of appliances to enable a load analysis to be calculated.	A fast system to compare appliances. Effective tool for decision making.	Ratings given can be subjective. If criteria is inadequate, highest ranked appliance may be inappropriate.	Researcher remains as objective as possible and rates appliances alongside clients. Update criteria as required throughout research.	A range of appliance specifications were collated for the cooktop, refrigerator and composting toilet from a wide variety of sources. Relevant appliances were weighted against criteria and then ranked according to each product's total score.
<p>Load analysis</p> <p><i>Results:</i> Section 5.2</p>	To identify opportunities to reduce electricity usage through suitable appliance selection by calculating the amount of energy required to run the PAB Gen-2.	A calculated figure in kWhrs/week.	Ensures appropriate selection and integration of correct components required to enable the PAB Gen-2 to be off-the-grid.	Figures given for appliance energy required are often estimates.	Allow for maximum energy requirements on all appliances.	Maximum energy ratings for all appliances applied to load analysis spread sheet supplied by Elemental Energy (New Zealand, 2009).
<p>Site Visits</p> <p><i>Results:</i> Section 5.3</p>	To investigate renewable energy implementation and/or other relevant architectural techniques employed. To record any visible issues regarding assembly and maintenance of off-the-grid systems.	Photographic documentation of existing system. Written documentation of perceived advantages and disadvantages of each system set up.	First hand evidence of on-site workings of systems. Useful documentation for developing more successful concepts.	Limited to New Zealand examples only.	Information was collected on the basis that it could be applied worldwide.	Sites were selected based on relevance to research question. Selected sites were varied and were explored first hand with residents.

Table 2. *Research for design methods – Part one* (Bowie, 2009).

Research for design methods

<i>Method (Results)</i>	<i>Method Aim</i>	<i>Method Objective</i>	<i>Advantages of use</i>	<i>Disadvantages of use</i>	<i>Minimisation of potential issues</i>	<i>Method Implementation</i>
Psychographic Audit <i>Results:</i> Appendix 11.7	Identify various psychographic segments.	Establish a range of common attributes, interests and values using products in same market.	Pinpoint common themes and issues addressed with products.	Lack of access to target market means findings can be inaccurate.	Wide range of lifestyles and interests investigated.	Brainstorm with clients regarding types of people who have enquired about the PAB & PAB Gen-2. Range of products investigated and imagery pulled together to view common links.
Semi-structured Interviews <i>Results:</i> Section 5.3	Address individuals involved in living with, setting up and maintenance of off-the-grid systems.	To gain primary information regarding the experiences involved with living off-the-grid such as unforeseen issues. Begin to form design criteria.	Personal insight gained. Pro's/con's discussed.	Off-the-grid residents are not fully considerate of design issues as often they do not set the system up themselves.	Range of participants interviewed including installers of systems aswell as residents.	Contact was made with electricians, renewable energy engineers, architects, an artist and the residents of the site-visits and informal interviews conducted using an outline of a series of relevant issues.
Scenarios <i>Results:</i> Appendix 11.9	To simulate a variety of user experiences with the PAB Gen-2.	Gather user experience attributes. Series of design issues and additional design criteria.	Broad array of users can be investigated to produce a wide range of design issues.	Due to lack of access to end users, simulation can be inaccurate.	Scenario characters were selected with varying backgrounds, families, wants and needs.	Mood board imagery was built up to depict characters and was used with a corresponding fiction-based narrative.
Concept sketching <i>Results:</i> Section 7.1	Generate concepts based on design criteria.	Concepts for evaluation.	Method is quick and used to aquire appropriate level of resolution.	Limited visibility when working with 3D products.	Used in conjunction with 3D prototype modelling.	Concepts were generated using a range of media. An iterative concept process built up an array of design concepts.

Table 3. *Research for design methods – Part two* (Bowie, 2009).

<i>Method (Results)</i>	<i>Method Aim</i>	<i>Method Objective</i>	<i>Advantages of use</i>	<i>Disadvantages of use</i>	<i>Minimisation of potential issues</i>	<i>Method Implementation</i>
Iterative concept development <i>Results:</i> Section 7.4	Develop a concept to a stage whereby it can satisfy most of the design criteria.	A rational design concept ready for modelling.	Concept flaws are refined with each iteration.	Can be time consuming before reaching suitable concept.	Use design criteria to evaluate each design.	Concepts were developed to level of resolution whereby they could be evaluated to extract pro's and con's for next iteration using a series of matrices. Evaluation had strong focus on performative and experience criteria.
Prototype & Model making <i>Results:</i> Section 7.4.1	To create and test mechanisms and 3D forms based on concepts.	Models that can simulate proposed mechanisms and overall design concept.	Quick technique to evaluate workings of concepts. Design issues highlighted.	Materials used can be inaccurate and lack appropriate resolution.	Use in conjunction with concept sketching.	Forms were produced in response to concept sketches and were created with enough resolution to test mechanisms where required. Storyboards generated using scale model to explain concepts in context.
User testing <i>Results:</i> Section 7.5	To observe user interaction with the product.	To test usability of product; difficulties encountered and aspects that are successful.	Researcher can observe, ask questions and photograph findings.	Varying practical skill levels between participants.	Gather a broad range of users with varying practical skill levels.	Users were given an introduction to the task at hand and asked to narrate their actions and thoughts as they carried out the task.
CAD modelling <i>Results:</i> Section 7.6	Visualise the design in three dimension.	A functional drawing to assess the performance based criteria.	Exact dimensions and proportions illustrate accurately the workings of mechanisms.	Lacks realistic consideration of materials and production processes.	Use in conjunction with tangible, three dimensional prototypes.	CAD programme Rhino was utilised once the basic concept for the solar array had been established and was aided by the use of prototype models for functional and aesthetic reference.
Evaluation <i>Results:</i> Section 8.1	Assess whether the solar array design fulfills design criteria outlined in chapter 3.0.	Determine how many design criteria are fulfilled by the final solar array design.	Provides reference for research 'through' design phase.	If set criteria are inappropriate then can affect the final design outcome.	Adjust criteria if necessary throughout research.	Design criteria used as reference for creative work throughout research 'through' design phase and final design evaluated against it to appraise outcome.

Table 4. Research 'through' design methods – Part one (Bowie, 2009).

Chapter Three Designing Experience

3.0 Hierarchy of Consumer Needs

Contemporary industrial design, whilst developing utility and usability aspects, also takes product experience into account. This research project has focused on two themes throughout the project; product performance and product experience. Product performance involves addressing the function and usability aspects in the operation of assembling the *Bach Pack*, ensuring the product is easy to assemble. In this context, the term 'experience' can best be defined by Hekkert (2007) as:

"The entire set of effects that is elicited by the interaction between a user and a product, including the degree to which all our senses are gratified (aesthetic experience), the meanings we attach to the product (experience of meaning), and the feelings and emotions that are elicited (emotional experience)" (as cited by Warell, 2008, p.4).

These characteristics are manifested in design strategist Patrick Jordan's work on usability, where performance is derived from dealing with the function and usability of the product and the experience is derived from developing the pleasurable and emotive aspects.

In 1997 Jordan released a modified version of Abraham Maslow's 'hierarchy of human needs' (1970) adapted as a 'hierarchy of consumer needs' in relation to products. The same principles are used whereby once one level of desire has been met, the consumer seeks the next, higher level and so on. Jordan's hierarchy suggests that functionality is the primary user need, followed by usability and finally pleasure. "The conclusion that can be drawn from Jordan's model is clear; consumers are now demanding more from the products that they buy than just adequate functionality and usability" (Chhibber, Porter & Porter, 2008, p. 326).

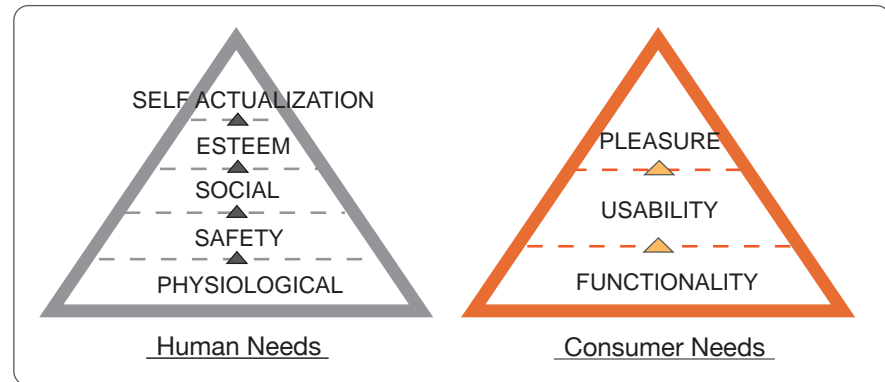

Figure 9. Hierarchy of human and consumer needs (Bowie, 2009 adapted from Maslow, 1970).



Figure 10. Perceptual product experience framework (Warell, 2007).

3.1 Perceptual Product Experience Framework

The *Bach Pack* has explicit requirements regarding function that are tangible and can be specifically designed for such as the design objective; to design connections to fix the components of the energy system. Designing 'experience' is a more abstract, less tangible quality. The Perceptual Product Experience (PPE) (Warell, 2007) framework is a useful mode of reference to use when designing for a high quality experience.

PPE is a useful theoretical framework because, "it can facilitate the designer's structured attempts to deliberately influence the experiential impact of new designs" (Desmet, 2007).

Specifically for this research, the PPE framework has fostered a process whereby components that make up the framework (i.e. emotion, recognition and comprehension) were used to associate with aspects of the *Bach Pack* design. The connections were used specifically when developing the experiential qualities of the solar array.

The *Bach Pack* product requires installation and deployment by the end user. It is through this interaction and direct contact the user has with the product that a pleasurable and meaningful experience is desired. The design work in this project has focused on developing the quality of this interaction in order to stimulate a pleasurable experience.

Emotion is the quality that underpins pleasure and this attribute has been unpicked by Desmet (2003) as represented in his Basic Model of Product Emotions (*Figure 11*). The model facilitates the, "study of emotional responses to consumer products. There are three universal key variables in the process of emotion elicitation: (1) concern, (2) stimulus and (3) appraisal" (Desmet, 2003, p.2).

Desmet's model builds on Jordan's framework regarding pleasure paradigms and develops an understanding of how we appraise product interaction based on the concerns of the user and the stimulus provided by the product. Appraisal can produce positive, negative, or no response.

3.2 The Four Pleasures

Anthropologist Lionel Tiger (1992) undertook extensive research regarding pleasure and developed a framework to model 'four conceptually distinct types of pleasure' (The Open University, 2004). Jordan (1997) adapted these to relate to product design. The four pleasures include:

Physio-pleasure: Includes sensory pleasures such as vision, taste, touch, sound and balance as well as tactile properties.

Socio-pleasure: Pleasure gained from relationships and interaction with others. Products may facilitate associations with particular groups or speak of a person's social identity.

Psycho-pleasure: This is closely related to cognitive and emotional reactions such as reactions to product usability. 'The feeling of satisfaction formed when a task is successfully completed and the extent to which the product makes the task more pleasurable' (Chhibber, Porter & Porter, 2009, p.329).

Ideo-pleasure: Concerned with the values embedded within a product.

The scope of this project, informed by an industrial design led approach, is to design to appeal to these pleasures by addressing the affective design experience involved with the assembly and deployment of the *Bach Pack*.

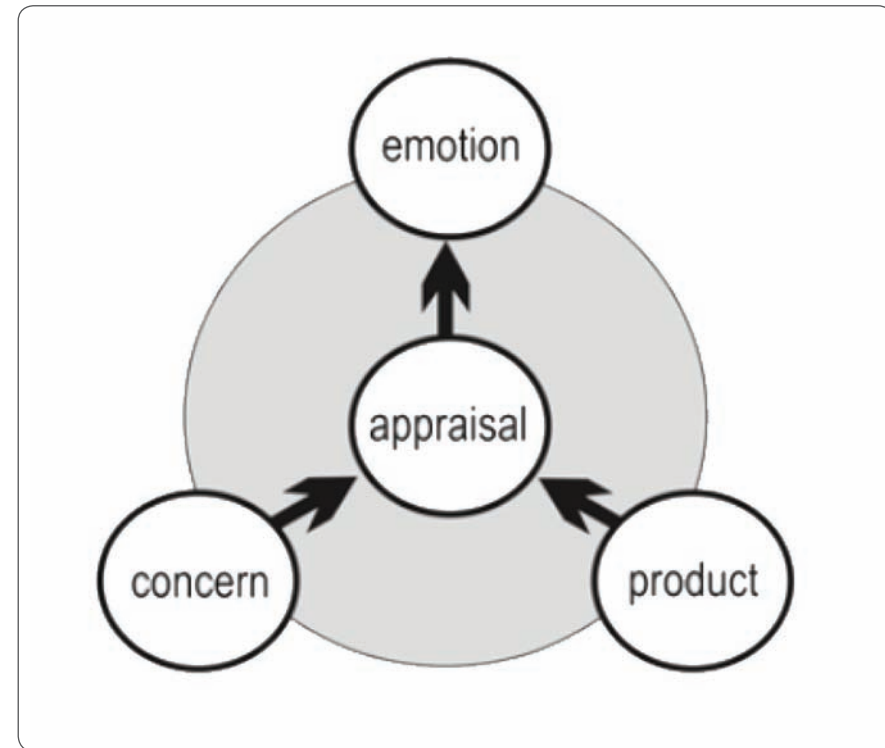

Figure 11. Basic model of product emotions (Desmet, 2003).

Chapter Four Contemporary Architecture & the Future of Self-sufficiency

4.0 Future of Architecture

The future of the manufacture of architecture is through prefabrication and off-site manufacture. In 2007, Canadian-American architect Witold Rybczynski commented that in the United States, “it has been estimated that as many as a third of all new single-family houses built are either modular or manufactured homes” (as cited in Bell, 2009, p.147). The merit of prefabrication lies in potentially achieving more environmentally considerate, high quality, reliable and efficient solutions than traditionally built homes.

“In the future, the houses we live in will be designed to function like living organisms, specifically adapted to place and able to draw all their requirements for energy and water from the surrounding sun, wind and rain. What is needed is respect (for) regional differences and environmental health while embracing appropriate technologies that can provide the comfort, service, and security we now expect”
(Berkebile & McLennan, 1999, p.160).

As designer William McDonough and chemist Michael Braungart comment, “modern industries still operate according to paradigms that developed when humans had a very different sense of the world. Neither the health of natural systems, nor an awareness of their delicacy, complexity, and interconnectedness, have been part of the industrial design agenda (2008, p.26).

The notion of ‘interconnectedness’ is becoming more widely understood and responses integrating architecture with renewable energy more common. The *PAB Gen-2* was conceptualised as a result of a market gap observed by Atelierworkshop

for an off-the-grid, short-term accommodation unit constructed using prefabricated techniques.

The market for renewable energy technologies and product is growing at a staggering pace. Research undertaken by Clean Edge (leading US research firm), reports that "global revenues for solar photovoltaics, wind power and biofuels expanded from \$75 billion in 2007 to \$115 billion in 2008" (Makower, Pernick, & Wilder, 2009, p.2).

The *PAB Gen-2* represents an amalgamation of themes and draws influences from the following which are discussed in this chapter:

- The Bach
- Prefabricated and Portable Architecture
- Shipping Containers and Container Architecture
- Renewable Technologies
- Solar Energy & Technologies
- Sustainable Architecture: Living Off-the-grid

Where applicable, one case study for each corresponding theme is investigated as a method of facilitating an understanding of the context. Details that can be linked to the development of the *PAB Gen-2* such as areas concerning services and renewable energy have been noted for the development of the design criteria for the *Bach Pack*.



Figure 12. *Early examples of kiwi bachs* (Bowie, 2009).

4.1 The Bach

It is important to understand the connotations of the word 'bach' as the *PAB Gen-2* was named deliberately to link with these associations.

The bach is renowned as a historic and cultural New Zealand icon. It is, "the name given to structures akin to small, often very modest holiday homes or beach houses" (Phillips, 2009). Baches became increasingly popular in New Zealand in the 1950s when roads were significantly improved and people were able to 'escape' from their day-to-day living to their 'bach retreat' and even today they are often referred to as the 'kiwi dream'. Early baches were small, simple and independent from amenities such as connections to the water and electricity grid. They were often rudimentary, ad-hoc structures built by the homeowner, using found resources and were ever-changing both with regards to size and aesthetics.

This 'do-it-yourself' (DIY) notion refers to home improvement undertaken without professional assistance and has become a common form of leisure and an attitude taken on by many New Zealanders.

In an article entitled 'The Simple Life' Johanna Thornton (2007, p.92) describes the bach as, "a dwelling that preserved the rituals of camping and caravanning, an uncomplicated ideal of holidaying." Wood (2009, p.44) agrees commenting that, "the bach seems to refer to a condition of living that is remarkable for its rejection of traditional home values. It is uncomplicated, primitive and rugged."

The bach as a term can be used to reference a 'type of living' (Wood, 2000, p.55) and is used as an opportunity to escape from everyday routine and to live differently. We all have different desires and needs to meet in terms of 'breaking away' and the *PAB Gen-2* provides an experience designed for those interested in pursuing an informal, 'grass roots' experience.

The original PAB was initially designed for the New Zealand context, however since manufacturing the prototype there was worldwide media fascination with the idea of the 'bach' and the associated traditional 'kiwi' values.

In relation to the concept of the *Bach Pack*, the *PAB Gen-2* links in with the DIY and bach culture described by building on the modularity of the unit with the development of the *Bach Pack* product. The *PAB Gen-2* is a contemporary take on the original bach.

 *Bach Pack* design criteria considerations:

- The product should imbue DIY characteristics as a leisure activity. The ease of use during the assembly process will determine whether the product is an enjoyable process or not.
- The aesthetic should reference the language of the bach (in this case the *PAB Gen-2*) and its materials: rugged and durable. A structure that visually looks reliable, as a shipping container does.
- The *Bach Pack* should ensure users are aware of their independence from council services.



Figure 13. Vintage portable architecture vs contemporary portable, prefabricated architecture. (Bowie, 2009).

4.2 Prefabricated & Portable Architecture

With regards to this project, prefabrication and portability are both provided by the use of a shipping container. This section discusses the evolution of these architectural fields as seen relevant to the *PAB Gen-2*.

Californian architect Peter DeMaria (2009) has extensive knowledge regarding fabrication and states that;

“New technology can be great, but some of the answers to our building challenges are right in front of us. We need to look more closely at existing materials and systems from commercial construction and other industries and ask how they might be adapted, adjusted, or recycled to meet our domestic architecture needs.”

In his essay entitled ‘The Commoditisation of Architecture,’ Eric Harker (2009, p.2) quotes Mies van der Rohe, “In case anyone regrets that the house of the future can no longer be made by hand workers, it should be borne in mind that the automobile is no longer manufactured by carriage makers.”

Kronenburg (2003, p.10) discusses the future of design and architecture and notes that, “many influential design professionals and commentators believe that flexibility and adaptability are intrinsic components of a forward-looking design agenda”.

Both prefabricated and portable housing have evolved from crude, primitive dwellings to sophisticated solutions exploring materials, construction and the adaptation of space. While design and architecture has made incursions into prefabrication, most production initiatives in this area have focused on cost reduction and not design and architectural refinement.

It is interesting to reflect on the design developments that have occurred over a number of years with regards to both prefabricated and portable architecture (Figure 13). Successful solutions were sought from both the manufacturing and energy management side. Contemporary examples such as the Micro-Compact Home (M-CH) demonstrate a currently available, mass manufactured modern solution and the Emergency Response Studio (ERS), which although not commercially available, is an off-the-grid solution and a significant case study for this project (case study reviewed in section 4.9). Other than the ERS, solutions for portable housing allowing the installation of renewable energy were difficult to find.

Of particular interest is the development of the area surrounding 'leisure and lifestyle dwellings' including recreational vehicles (RV). The same characteristics and user needs apply to early versions of the RV as they do to the *PAB Gen-2*. These include:

- Space to sleep, eat and wash
- Versatile and adaptable spaces: quick to assemble and disassemble
- Affordable yet robust, portable dwelling

4.3 Case Study: **Micro-Compact Home: Horden Cherry Lee Architects, London, United Kingdom (2005)**

The M-CH is a prefabricated, 2.6m cubed, cube designed as a short-stay, smart living unit. The M-CH uses traditional timber framing construction and anodised aluminium cladding as the exterior. The interior has been influenced by traditional Japanese teahouses, with zones used to divide the space allowing for a fridge, electrical hobs, microwave, two compact double beds, a bathroom, storage, heating and air conditioning, water heating and a television.

The unit requires connection to local services including electrical supply, water and

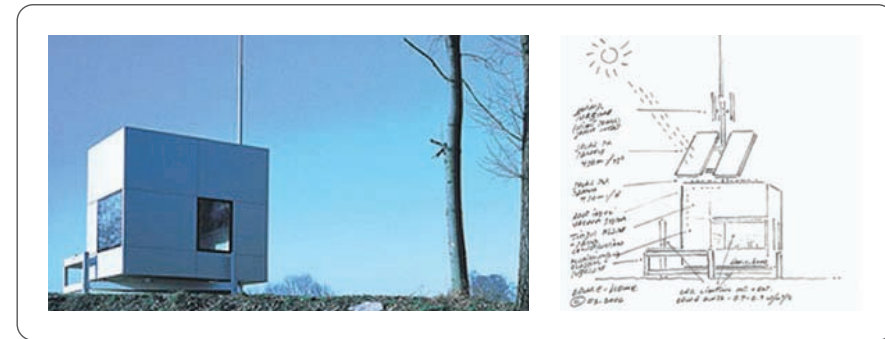

Figure 14. *Micro-compact home* (Bowie, 2009).

drainage. A more recent version has been conceptualised called the Micro Compact Low E-Home, which includes the installation of photovoltaic solar panels and a small wind turbine. Both versions of the M-CH require hired assistance to install the unit by a paid professional.

The M-CH is in production and including delivery, installation and connection to services costs NZ\$110,000.

 *Bach Pack* design criteria considerations:

- Leisure dwellings entail attractive attributes that draw people to 'want' or 'need' them. This emotional desire to want to own the product should be embodied in the design of the *Bach Pack* both aesthetically and functionally.

4.4 Shipping Containers & Container Architecture

The shipping container, often referred to as an “icon of globalisation” (Sylvester, 2003) has evolved as a transportation vehicle, into a contemporary, cosmopolitan style of architecture.

Utilising an existing structure as the basis of a dwelling can result in substantially lower construction costs and subsequently a more accessible form of architecture. “Sky high prices of real estate in the western world have stimulated the search for and development of alternative construction solutions, and one such attempt is container architecture” (Kotnik, 2008, p.20).

Toward the end of the 1960's, the International Organisation for Standardisation (ISO) recommended standardisation for containers globally. As of 2005, some 18 million total containers make over 200 million trips per year (Levinson, 2006). The widespread use of ISO shipping containers has resulted in an abundance of redundant containers. In his research paper 'Shipping Containers as Building Components' J.D. Smith (2006, p. 31) suggests as many as 125,000 abandoned containers to be clogging Great Britain's ports, and around 700,000 in the USA (Kotnik, 2008, p.16).

“Shipping containers surpass the necessary characteristics sought in traditional architectural designs. The sturdiness of the containers' outer shell resists any on-site manipulation and withstands the worst of weather conditions – the cold and heat, as well as salty water, high winds, downpours and other inconveniences. The fact that containers are primarily used in transport and that architects can borrow them as needed is an important advantage. There is no need to set up a new system of construction, since this existing one already has all the necessary advantages” (Kotnik 2008, p.14).



Figure 15. Redundant shipping containers (Hasan, 2009).



Figure 16. Container house (Bowie, 2009).

Greater significance is being placed on designing buildings with a light ecological footprint as well as minimising the obtrusive nature of structures on the landscape. Container constructions do not require site excavation and also comply with the '3R' phrase that has resounding significance: reuse, recycle, reduce.

What is of interest are the various ways that examples of container architecture capitalise on the use of the existing structure by adding to and building from the core element. Although many examples have been modified as portable living units, few allow the complete independence offered by the *PAB Gen-2* which can be described as an 'independent battery' (Giesen, personal communication, March 3, 2009).

4.5 Case Study: Container House: Ross Stevens, Wellington, New Zealand (2007)

The 'Container House' was designed and built locally by industrial designer Ross Stevens as an 'experiment' for his post-graduate research. Steven's believes architecture can usefully explain how things change through time, and this was the basis for his research.

The three shipping containers are stacked and positioned in a rocky hillside in south Wellington. Upon interviewing Stevens, he spoke of the materiality of the containers and the issues he faced whilst building. Stevens utilised refrigerated rather than standard containers, which are insulated.

"The reason for using containers comes from my industrial design background. The idea of a factory built house that was very strong and light - both critical for an earthquake zone - fast to assemble, cost effective and well insulated seemed a more sensible answer. From an aesthetic perspective, the reused industrial materials also

had a humility and history that appealed. The nature of the site combined with the threat of falling rock also required a robust, non domestic answer”

(Stevens, personal communication, November 19, 2009).

Stevens' use of the containers for their robust nature is appropriate for his site. He has created a living space that extends out into the open spaces created on the hillside of the containers. A conservatory space is framed literally by the steel substructure of a container and where possible fixings and construction details are exposed. This embodiment of security and durability is augmented right through the building. The use of off-cut material from the containers is evident as furniture, a deck and several doors.

Stevens describes himself as a designer focused on 'sustainable decadence' (Stevens, personal communication, April 7, 2009). As such, his current project includes developing a single off-the-grid container next to the current ones. "My vision is to have no letter box – i.e. no bills" (Stevens, personal communication, November 19, 2009).

 *Bach Pack* design criteria considerations:

- Take advantage of the existing structure and what it provides, as this will enable a more seamless integration between the existing structure and the additional product.
- Attachments should be exposed where possible as visual representations of durability and reliance.

Both case studies presented so far, show a common progression in the future of their architecture. The designers of each are pursuing off-the-grid versions of their current buildings.

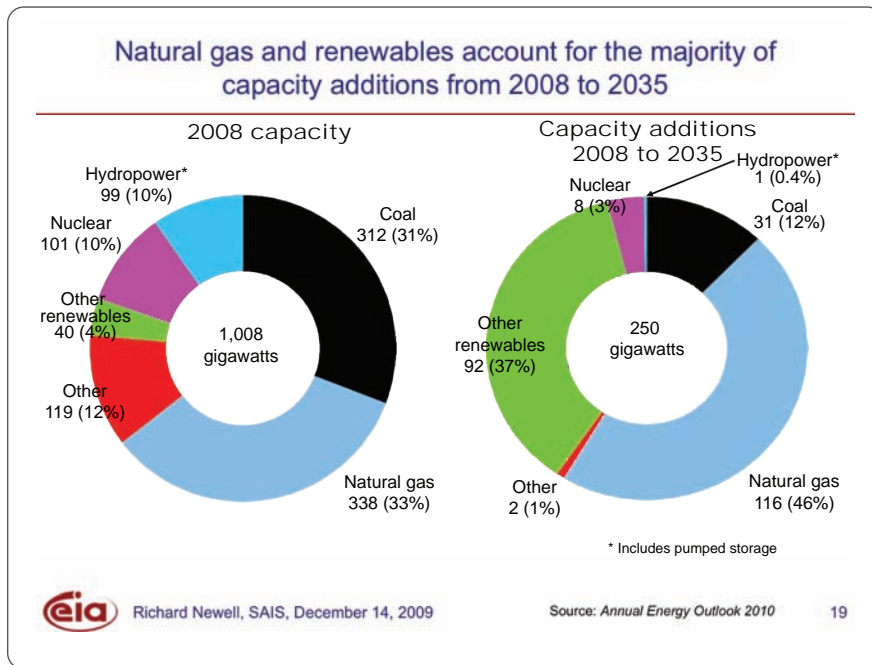

Figure 17. Annual energy outlook 2010 (Newell, 2009).

4.6 Renewable Energy

The renewable energy industry is growing rapidly as people realise our dependence on oil cannot last. A report released by the American Electric Reliability Council in 2006 concluded that, "U.S. electricity demand will significantly outstrip supply during the next 10 years" (Gerlat 2006, p.8).

David O'Reilly (2005), chairman and CEO of major oil company Chevron Corporation made the following statement:

"Energy will be one of the defining issues of this century. One thing is clear: the era of easy oil is over. What we all do next will determine how well we meet the energy needs of the entire world in this century and beyond" (as cited by Kisslinger, 2009).

In 2001, the world consumed energy at an average rate of more than 13 trillion watts according to the U.S. Department of Energy. Taking into account population increases, worldwide economic growth and conservation and energy-efficiency measures, some researchers predict that the global energy-consumption rate will double by 2050 and triple by the end of the century (Cunningham 2007, p.328).

The transition to more sustainable energy sources is inevitable and is being supported by large programmes designed to research and implement appropriate technologies to lower the reliance on oil and fossil fuels. The American Recovery and Reinvestment Act of 2009, signed into law by President Obama in February, includes more than \$70 billion in direct spending for clean-energy and transportation programmes. This policy-stimulus combination represents the largest federal commitment in U.S. history for renewables, advanced transportation, and conservation initiatives (Makower, Pernick, & Wilder, 2009, p.6).

“Non-hydro renewable sources of electricity enjoyed double-digit growth during the past year while coal, and petroleum experience notable declines...according to the latest figures published by the U.S. Energy Information Administration (EIA)” (as cited by New Net, 2009). *Figure 17* illustrates the forecasted growth in renewables as predicted by the EIA.

4.7 Case Study: **Eco-Nomad Combined Mechanical Utility Container: Ontario Centre for Environmental Technology Advancement (OCETA): Manitoba, Canada (1999)**

The Eco-Nomad is described as a complete micro-infrastructure that ‘provides utility services to off-grid residential, small commercial or institutional buildings’ (OCETA, 1999).

The prefabricated shipping container can be installed as an individual unit or linked to several units to support larger networks for both existing and new buildings. The portable utility houses proven technologies and includes electrical supply, potable water purification and storage, biological wastewater treatment and heating for water and spaces. Most of the electricity is gained via a micro co-generation engine, while energy collected by solar panels and the wind turbine are supplementary.

The Eco-Nomad Utility Container can be transported by road, rail, water or air followed by an installation time of 24 hours. An average sized system costs approximately NZ\$96,000.



Figure 18. *Eco-Nomad* (Bowie, 2009).

 *Bach Pack* comparison:

The Eco-Nomad is a facility that enables independence from the grid, the same objective as the *Bach Pack*. The difference lies in the detached nature of the unit, which in the case of the *PAB Gen-2* requires integration.

The blending of architecture with renewable energy technologies was inevitable. Integration of these technologies into domestic homes assisted with closing the gap between consumers and renewable energy by presenting the technologies on a micro scale (*section 4.8*). The set-up involved with most domestic systems requires professional assistance specifically due to the technical configuration. This differs from the *Bach Pack*, which is an initiative to present renewable energy technology to the user in a more accessible, DIY fashion. It acts as a transitional product allowing those curious about living off-the-grid an opportunity to do so as a temporary measure. The product must therefore be designed for users with basic practical skills so that it can be attractive to a wider audience.

4.8 Living off-the-grid

The choice of living off-the-grid presumes the assumption of a certain degree of commitment from the end user. Although the inclusion of renewable energy has become more common, the buildings are often grid-tied, whereas living off-the-grid is complete removal from municipal facilities. As Buckminster Fuller (n.d) stated:

'In the rapidly dawning era of necessary environmental responsibility, architecture will flourish if it replaces the haughty metaphor of buildings as machines with the holistic metaphor of buildings as flowers. We do not seek to imitate nature, but rather to find the principles she uses' (as cited in Berkebile, 1999, p.160).

"Going off-grid is nothing new; it's just a revitalisation of old lifestyles," (Black, 2008, p.188) and can best be described as an 'interconnected' lifestyle mimicking nature's principles in order to gain energy and water. It can be done to lower the environmental impact of living, as the typically limited amount of on-site renewable energy available is an incentive to reduce its use. It is often done to residential buildings only occasionally occupied, such as vacation cabins (The Off Grid Home, 2008).

"In our five years of life with solar power, we have made some minor adjustments in our lifestyle, and certainly added to our mechanical knowledge, but overall have discovered that life for us, and for our neighbors, is not that different from that of the power-connected world (Kelly, 1995).

Leaving the 'grid' has become an increasingly prevalent trend, particularly in the USA. In 2006, USA Today reported that there were "some 180,000 families living off-grid, a figure that has jumped 33% a year for a decade," and cited Richard Perez, publisher of Home Power magazine, as the source (as cited by The Off Grid Home, 2008.)

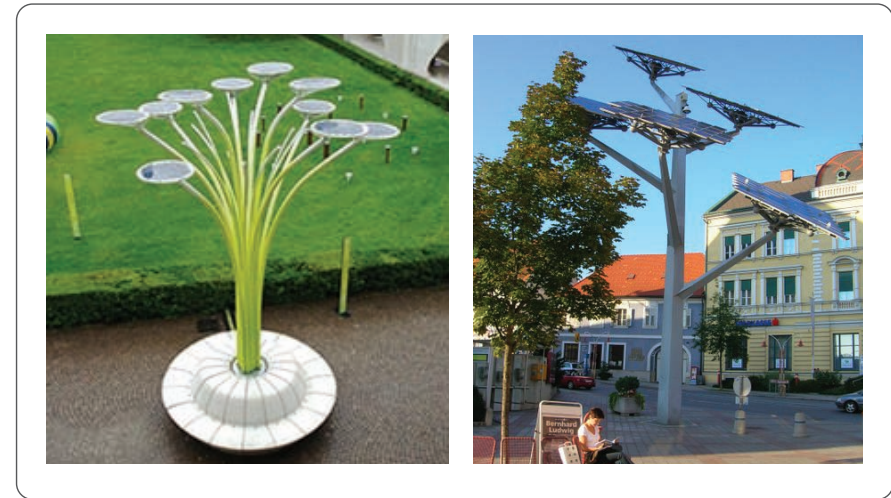

Figure 19. Contemporary biomimicry (Bowie, 2009).

It is difficult to give exact figures, however in the United Kingdom it is estimated that '40,000 have gone off-grid' (Kermeliotis, 2009). Rosen (2009) says, "I see people who live off-grid as the foot soldiers of the environmental revolution, the early adopters of what we will all have to do in the very near future" (as cited by Kermeliotis, 2009).

 *Bach Pack* design criteria considerations for off-the-grid operation:

- The *PAB Gen-2* seeks to act as a transitional product, allowing consumers to create a relationship with renewable energy on a micro scale. The *Bach Pack* should enable and encourage this relationship by ensuring end users are aware of their surroundings, their energy supply and consumption.
- End users that select to purchase a *PAB Gen-2* will be aware of the input required however the addition of the *Bach Pack* should enhance their experience with the dwelling. An enhanced experience should include consideration of the four pleasures, such as specific attention to the 'touch points' or areas of direct contact on the *Bach Pack*.
- The *PAB Gen-2* relies on solar energy however site locations will be inconsistent. The *Bach Pack* will require adaptation depending on each site therefore the product should be able to tailor to all sites regardless of their relative positioning to the sun.

4.9 Case Study: **Emergency Response Studio: Paul Villinski, New York, USA, (2008)**

The ERS was a responsive project undertaken after Hurricane Katrina devastated many communities on the Gulf Coast of the United States in 2005. Villinski, an artist, used a Federal Emergency Management Agency (FEMA) trailer to create an off-the-grid mobile artist's studio.

The website for the ERS states that:

“Though designed as an artist’s studio, the Emergency Response Studio also serves as a prototype for self-sufficient, solar-powered mobile housing, and explores the application of sustainable materials in the construction of trailers and other forms of temporary housing” (Villinski, 2008).

The ERS interior contains a small bedroom, bathroom and a kitchen containing a stove, refrigerator and hot water all powered using propane gas. Nine solar panels are mounted to the roof of the ERS collecting the majority of the 6000W of power and providing ample energy to power lights, music devices, a computer and battery charger. Hinged to the front of the trailer is a small wind turbine that supplements the energy the solar panels collect. In conversation, Villinski commented that, “the solar panels contribute the most power, however the turbine is a visually important and symbolic component of the ERS” (Villinski, 2009).

In a telephone conversation with Villinski (personal communication, June 18, 2009) he explained that he had professionals install the solar panels using a commercially available stock rack system but commented that, “there would be huge benefits in designing a more accessible product that could enable consumers to set up part-of or their entire own off-grid system” (Villinski, 2009). Although Villinski was interested in developing a simple product solution, he stated that:

“The ERS was always intended to be a one-off piece used by me and the assembly and set up of the energy system was not a priority for the project. Therefore there was not a lot of consideration when it came to attachments and the overall user-experience associated with energy system” (Villinski, 2009).



Figure 20. Emergency Response studio (Bowie, 2009).

The ERS is the nearest realised example of portable, off-the-grid housing to the *PAB Gen-2*. The renewable energy system produces energy that exceeds the amount of energy actually required to run the unit. The entire roof and one front face of the studio is loaded with solar panels without calculation of exactly the number required. Significance for the project was placed on the ERS being a visual exercise, rather than a functional assignment.

 *Bach Pack* design criteria considerations:

This case study is a useful example of a functional prototype that can usefully advance this project directly by looking at the use of attachment and deployment of the solar panels on the ERS.

- The *Bach Pack* should aim to reduce the cumbersome aesthetic of the solar panels by designing a more tailored attachment solution than the ERS.
- The attachment should consider the portable nature of the *PAB Gen-2* and therefore consider both the assembly and disassembly process carefully.

4.10 Case Study: **The Yacht**

For yachting enthusiasts, living off-the-grid is an old concept entailing similar performance and experience attributes to those of the *PAB Gen-2*. Yachting requires participants to strike a balance between the manual operations on board and the conditions exposed by the elements. This challenge is aided by the use of specifically designed fittings and fastenings suitable for the yachting environment.

Appliances and technologies in yachts vary depending on the size and use of the yacht, but a standard set up includes a fridge, freezer, cook top, oven, water and space heating and lighting. Cook tops are usually gas whereas the other appliances run on 12 Volt (V) supply. Drinking water is stored in the hull and is topped up at

ports. Batteries are topped up with power when the motor is running and can then power the appliances. On longer voyages however, renewable technologies including solar panels and wind turbines are used as a means to keep the batteries topped up when the yacht is stationary for longer periods. They are also used for powering interior lighting, radios, navigation instruments and water pumps.

Many of the smaller wind turbines used on properties on land are actually designed specifically for yachts. The sea is the ideal place to harness the wind for energy since it is a vast, open space and there is almost always a breeze. With the ever-changing conditions, yachts must be adaptable to change efficiently with ease. Manual operations such as cam cleats and pulleys are commonly used to assist users in manual adjustment of sails and ropes.

Bach Pack design considerations:

The yacht is a useful case study to reference when designing for performance and experience as it fuses the notion of leisure with DIY with an overriding requirement for reliability and ease of use. The performance of the *Bach Pack* attachments and fastenings should associate with those used for yachting including:

- Use of manual fastenings
- Visual confirmation of adjustment and securing of fastenings
- Provision of a sense of reliability and security

The experience of the assembly and deployment of the *Bach Pack* should also draw from yachting attributes:

- Imbuing the user with a sense of empowerment, accomplishment and satisfaction upon interaction

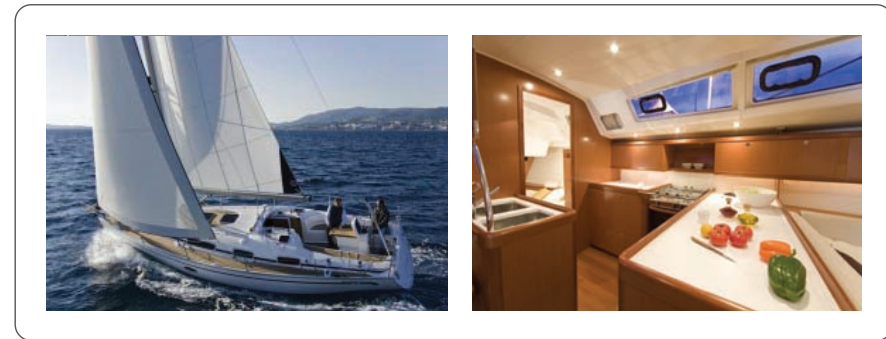

Figure 21. *Living off-the-grid on a yacht* (Bowie, 2009).

4.11 Case Study Analysis

In summary, the performance and experience characteristics of these case studies and the *PAB Gen-2*, as compared in a visual table, link the similarities and differences based on the design intentions of the *Bach Pack* thus locating the *PAB Gen-2* within the current market of mobile dwellings. Performance and experience characteristics are not quantifiable in this instance, therefore the aim of *Table 5* was to link and rate less tangible qualities by investigating each case study's design features employed and the level of experience associated. These performance and experience characteristics were used as initial design criteria and case studies were appraised accordingly alongside the clients.

Table 5 shows clearly that the *PAB Gen-2* aspires to similar performance and experience attributes to that of the yacht. Other points of interest include:

- As seen with the Eco-Nomad and the ERS, aesthetic value can be compromised with the addition of renewable technologies, whereas the yacht and M-CH are able to keep their architectural integrity without the interference of technologies.
- From another perspective, sustainable integrity is more obvious to a wider audience with the addition of noticeable renewable technologies.
- The consequence of a higher level of user interaction is a higher level of end user experience.

To explore the relationship between end user interaction and experience, bi-polar charts were used. Analysis was undertaken to establish connections between on-the-grid and off-the-grid case studies and their level of end user interaction. This helped establish where the *Bach Pack* should sit in relation to the off-the-grid case studies.

Case study analysis

Criteria for PAB Gen-2		M-CH	Container House	Future Shack	Wee House	Eco Nomad	ERS	Yacht
<p> ■ High ■ Medium ■ Low N/A </p>								
Performance	Robust, reliable structure	Medium	High	High	Medium	High	Medium	High
	'Plug & play' unit	Medium	Low	Low	Low	Medium	High	N/A
	'Add-on' features cause little interference with structure	High	N/A	Low	N/A	N/A	Medium	High
	Few practical skill required for use	High	High	Low	High	Low	Medium	Low
	Integrated inclusion of renewable technologies	N/A	N/A	N/A	N/A	High	High	High
	Renewable technologies require little space	N/A	N/A	N/A	N/A	Low	Low	High
	Renewable technologies are removeable	N/A	N/A	N/A	N/A	Low	Medium	Low
Renewable technologies deployed by users with ease	N/A	N/A	N/A	N/A	Low	Medium	Medium	
Experience	Unit expresses portable, compact nature	High	Low	Medium	Medium	Low	High	High
	Emits relaxing & holiday based emotions	Medium	Low	Medium	High	Low	High	High
	Conveys sustainable principles	Medium	Medium	Medium	Low	High	High	High
	Speaks of a different, special experience or event	High	High	High	Low	Medium	High	High
	Sensory experience	Medium	Medium	Medium	Low	Low	Medium	High
	Uncompromised aesthetic attributes	High	High	Medium	High	Low	Medium	High
	Requires user interaction resulting in a higher quality user experience	Low	Low	Low	Low	Low	High	High
	Technologies required are discreet	N/A	N/A	N/A	N/A	Low	Medium	High

Table 5. Case study analysis (Bowie, 2009).

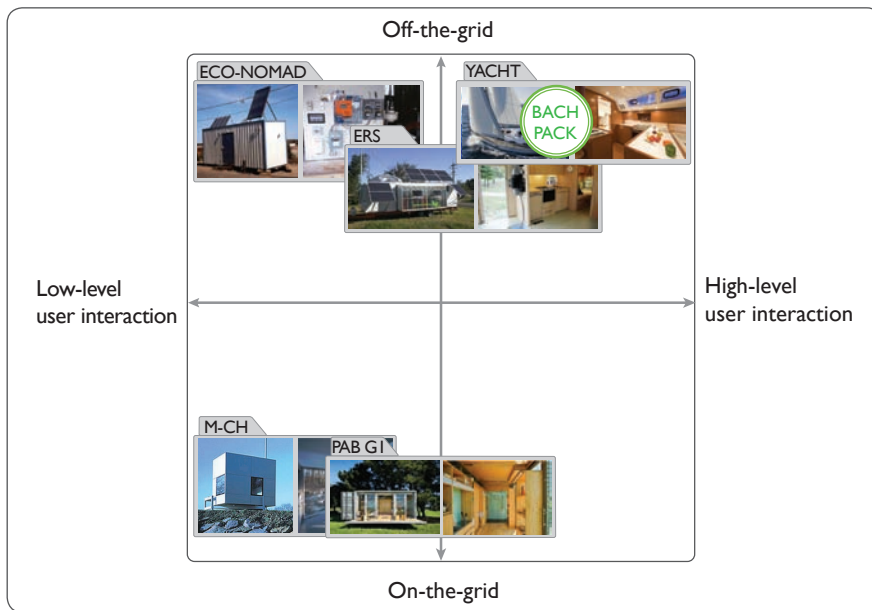

Figure 22. User interaction against on and off-the-grid dwellings (Bowie, 2009).

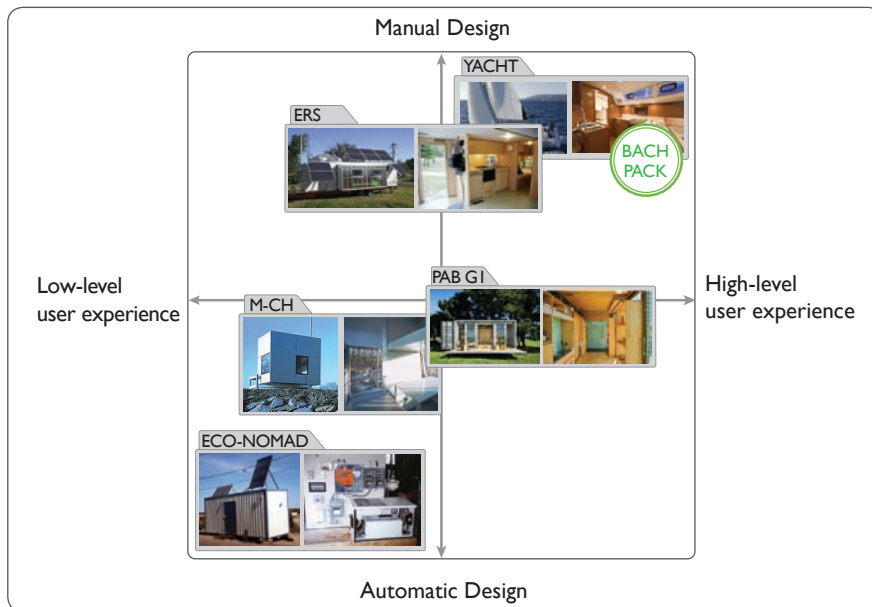

Figure 23. End user experience against type of design used in off-the-grid dwellings (Bowie, 2009).

The bi-polar chart in *Figure 22* shows that the *Bach Pack* should require a high level of end user interaction; more than the ERS but less than the yacht. It also highlights the level of aesthetic complexity bought on by renewable energy that the *Bach Pack* should try to avoid.

User interaction (and appraisal) is affected by end user contact with products (stimulus). To establish the type of design that will impart a high end user experience, a second bi-polar chart was undertaken to place case studies according to their use of manual or automatic design. This was required in order to establish which design style delivered a higher level of user experience from the case studies reviewed.

Figure 23 illustrates that in order to create a higher level of end user experience, manual design features should be considered. The chart shows those case studies that require little or no input from end users to set up, result in a lower level end user experience. For example the Eco-Nomad is set up by trained professionals and once activated has no connection with the end user. This was designed intentionally as a product that automatically adjusts the system depending on the circumstances, however the end user is not bought into contact with the technology. This is the opposite effect that the *Bach Pack* aims to have whereby contact enables control and knowledge of surroundings and the technologies involved.

4.12 Existing Solar Arrays

Many residential homes that integrate solar PV, do so with existing buildings which makes integration of the panels significantly more difficult than if one were building from scratch. *Figure 24* presents common examples of rooftop solar arrays.

Other homeowners choose to separate the panels from the house by building a solar array structure that the panels can be mounted to (*Figure 25*).

Existing solar array 'products' as such, are not available as commercial products for non-professionals. Solar panels require electrical wiring by an electrician and installing the solar array frame requires building knowledge and a range of tools to ensure correct, secure installation.

Table 6 exhibits several solar array designs that were investigated to initiate an overview of what each involved in terms of skill level, design, materials and advantages and disadvantages.

Several conclusions were made regarding the solar arrays investigated:

- Most solar arrays are designed for function with little regard to aesthetics and reducing the visual impact of the array.
- DIY installation of solar arrays also link with utilising stock standard materials suggesting the use of familiar materials is beneficial in simplifying the assembly of the array.
- The material of choice for all solar arrays is metal. Aluminium extrusion and tube is used in three of the five arrays. The remaining two examples utilise steel.



Figure 24. *Solar panels integrated into residential properties* (Bowie, 2009).



Figure 25. *Stand alone solar array frames* (Bowie, 2009).

Existing solar array comparison





Criteria		Solar Stick	Eco Innovation	Carterton rooftop array	Emergency Response Studio	Container Array
Solar Array						
Skill	Level of skill/practical knowledge required	○○○○○○○○	●●●●●●●●	●●●●●○○○	●●●●●○○○	●●●●●●●●
	Number of people required for installation	1 person icon	3 people icons	2 people icons	1 person icon	3 people icons
Design	DIY	✓	✗	✓	✓	✗
	Design for disassembly: 'removeable'/packable'	✓	✗	✗	✓	✗
	Universal design: 360 degree rotation	✗	✓	✗	✓	✗
	Aesthetic value	Moderate	Low	Low	Moderate	Low
	Cost	\$	\$\$\$	\$\$	\$\$	\$\$\$
Materials	Standard parts & materials used	✓	✗	✓	✓	✓
	Structural strength	○○○○○○○○	●●●●●●●●	●●●●●●●○	●●●●●●○○	●●●●●●●●
Advantages/Disadvantages	Advantages	- Portable - Low tech	- Anti-theft - Exceptionally strong	- Low-tech - Simple structure	- Portable - Structure can lie flat	- Exceptionally strong
	Disadvantages	- Low energy output - Easy access for tampering	- Huge structure - Aesthetically obtrusive	- Ad-hoc fixtures - Aesthetically obtrusive	- Ad-hoc fixtures - Aesthetically obtrusive	- Large material quantity - Aesthetically obtrusive

Table 6. Review of existing solar arrays (Bowie, 2009).

Figure 26 shows the correlation between the level of design and cost of a variety of solar arrays. It is difficult to make a fair comparison of the arrays due to variable sizes of solar arrays however it is useful to indicate where the *Bach Pack* should aim to fit in amongst these examples.

Current renewable energy technologies such as solar panels are advanced in their technological design, however attachments and fixings are ad-hoc and lack the connective tissue that enables seamless integration. In order to engage users in a high level of product experience, the *Bach Pack* should seek to infuse them with a sense of reward and satisfaction both whilst assembling and upon completion of the solar array. The founder of Frog Design, Harmut Esslinger said that, "...no matter how elegant and functional a design, it will not win a place in our lives unless it can appeal at a deeper level, to our emotions" (Desmet, 2008, p.325).

When referring to renewable energy hardware, Matt Scanlon (1994), journalist for Mother Earth News writes, "This whole process should be easy anyway. People need to work out they can do it."

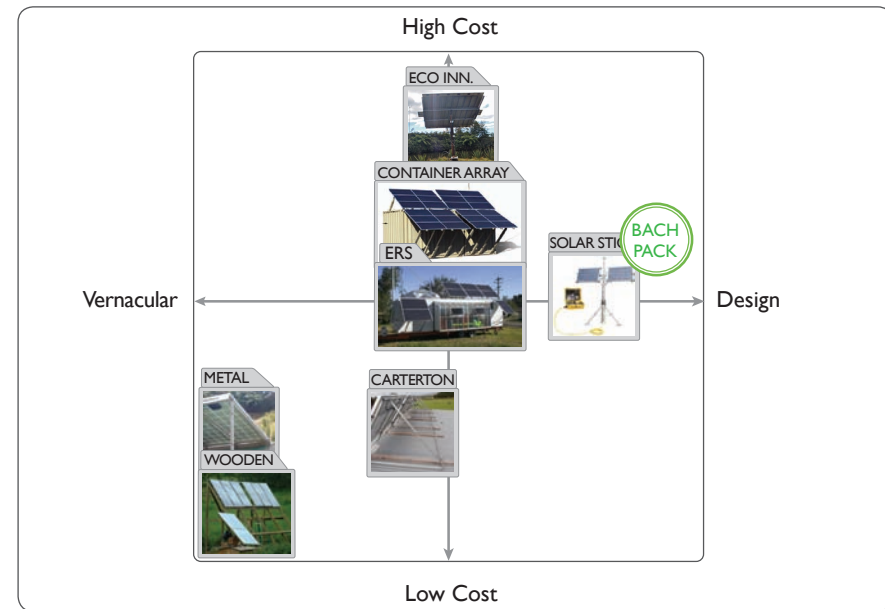

Figure 26. Solar array level of design against cost (Bowie, 2009).



Figure 27. Solar array frames: materials and method of attachment (Bowie, 2009).

4.13 Experience Forecast & Appraisal

Prior to embarking on the research for design methods, a forecast appraisal was carried out as a method of predicting the end user concerns directly associated with the activities outlined in *section 1.3* with regards to the *Bach Pack* product.

Table 7 applies both Jordan and Desmet's theoretical models (*section 3.0*) to the development of the *Bach Pack* product, resulting in a preemptive positive appraisal. This was a useful task as it enabled the researcher to highlight initial concerns and to work with them whilst undertaking research.

End user concern, experience & appraisal forecast

<i>Primary Objective:Activities</i>	<i>Function</i>	<i>End User Concern</i>	<i>Experience & Appraisal</i>
<p>Calculate necessary energy required for an average of 3 people living in PAB Gen-2</p>	<ul style="list-style-type: none"> - Correct selection, suitable size and number of components - Consideration of climate i.e. sunshine hrs 	<ul style="list-style-type: none"> - Will we produce enough energy to meet our needs? - How much energy have we collected? - How much energy do we have left? - Will the Bach Pack work when weather conditions are not favourable? - Is the Bach Pack reliable? 	<p>POSITIVE!</p> <ul style="list-style-type: none"> - Appliances can be used at all times due to energy consumption calculation - Energy availability can be viewed on the solar controller specified
<p>Specify existing components that will enable the PAB Gen-2 to be self-sufficient with regards to energy</p>	<ul style="list-style-type: none"> - Appropriate selection of existing, proven technologies - Harness and store energy for use in the PAB Gen-2 		<p>POSITIVE!</p> <ul style="list-style-type: none"> - Use of existing, proven technologies creates a sense of reliability
<p>Design and select the appropriate location and configuration of the required components</p>	<ul style="list-style-type: none"> - Specify sub-component location so that connections can be designed accordingly - Secure connection of the sub-components to the exterior of the PAB Gen-2 - To gain maximum energy 	<ul style="list-style-type: none"> - Are the connections attached correctly? - Are the components safe and secure? 	<p>POSITIVE!</p> <ul style="list-style-type: none"> - Intuitive assembly process, natural progression - Positive sensory experience ('clicks' and visible indicators allowing the senses to confirm that the attachment is in place - End user completes the installation with a feeling of accomplishment and reward.

Table 7. Bach Pack forecast appraisal (Bowie, 2009).

Chapter Five Results & Discussion of Solar System Research

5.0 Research for Design Overview

This section covers three vital research methods that were undertaken prior to the creative investigation. Results for the following methods are discussed in this section:

- Appliance analysis
- Load analysis
- Site visits and semi-structured interviews

Information gained from this section provided a foundation for the selection and configuration of the system components. The results from these methods fed the development of the design criteria and subsequently molded the final output.

5.1 Appliance Analysis

Aim

The aim of the appliance analysis was to select the appropriate appliances within suitable energy capacity of the *PAB Gen-2*.

Objective

To utilise an adapted version of Stuart Pugh's (1990) 'concept selection' matrix whereby concepts (in this case appliances) are compared and ranked using suitable criteria as an effective tool for decision-making.

Discussion & Results

Matrices have been used throughout the project as an effective selection strategy. In this instance, appliance comparison and selection was required for the cooktop, refrigerator and composting toilet. Criteria specific to the *PAB Gen-2* was formulated and appliances jointly rated by the project team (Atelierworkshop and their researcher). *Table 8* outlines the selected appliances ranked number one based on their total score with regards to the specified design criteria (*Appendix 11.2-11.4*).

- The initial products desired for the *PAB Gen-2* included an induction cooktop and a heat pump. After calculations were made for the load analysis (*section 5.2*) it was clear that the figure far exceeded the expected power input for such a unit and was attributed to the inclusion of appliances requiring high power input. After re-evaluation, a decision was made by the project team, to maximise insulation and air flow in place of the heat pump and to use a gas cooktop rather than electric.
- Appliance selection allowed the components required for the independent energy system to be configured appropriately.

Appliance specifications



<i>Specifications</i>	<i>Refrigerator</i>	<i>Cooktop</i>	<i>Composting Toilet</i>
			
Product Name	Serada C501	Baumatic FG2SS	EcoJohn
Dimensions w x d x h (mm)	400 × 390 × 640	288 × 510 × 50	863 × 635 × 635
Power Use	13 W/hr	Av. 7.2 MJ/hr	0.26kW/day
Power Voltage/Source	12/24V	Gas	12/24V
Capacity	50 Litres	n/a	Full time 3 people - empty box every 3-4 weeks
Weight (kg)	15.7	3.1	20
Materials	Heat bonded stiple surface - melteca type surface	Stainless Steel	Plastic
Retail Outlet	Serada	Kitchen Things	Ecojohn.com
Price (\$NZ)	\$1,567	\$329	\$1,982

Table 8. Appliance specifications (Bowie, 2009).

5.2 Load Analysis

Aim

The load analysis aimed to gauge the estimated power required to run the *PAB Gen- 2*.

Objective

To prescribe the components which enable the off-the-grid system.

Discussion & Results

The following issues were identified and processed accordingly:

- To be viable as an international product, the *PAB Gen-2* required compliance with international electrical power systems that vary world wide between 110 and 240-volt. Campervans and caravans usually run 12V systems which are considered more straightforward electrical systems and therefore ideal for the *PAB Gen-2*. This system eliminates the necessity for an inverter and is universally, a more compatible system.
- Consideration of inclement weather: Investigation into the approximate number of consecutive inclement days was undertaken on several site visits. A maximum of 2.5 days was logged on solar controllers as the longest period without solar energy input. This was taken into consideration when calculating the total energy needs of the *PAB Gen-2*.
- The initial load calculation (*Appendix 11.5*) was based on the inclusion of a heat pump and induction cooktop (*section 5.1*). This translated into a requirement for ten solar panels, a huge number considering the size and nature of the unit. By using gas to heat water and run the cooktop, the load was significantly decreased to four solar panels.
- A final estimate of 3.13 AC kW hrs/week was calculated for the *PAB Gen-2* requiring the installation of four solar panels, four batteries and a back-up generator in conjunction with gas.



Figure 28. Testing configurations for the generator and batteries using a scale model (Bowie, 2009).

Minor adjustments undertaken early on in the design process (such as those regarding appropriate appliance selection) can have long term negative effects, therefore it was important to recognise this early on and respond accordingly. The Emergency Response Studio (ERS, section 4.9), is an example of a product outcome that neglected to undertake a load analysis. The ERS supports nine solar panels and a micro-wind turbine, which are used simply to light the interior space. The rest of the appliances run off propane gas.

Table 9 outlines the electrical system components that enable the *PAB Gen-2* to run off-the-grid. A summary of the independent energy system can be viewed in Table 10.

Calculating the load analysis was critical as it enabled the specification of components required to run the off-the-grid system and consequently the scope of the design of the *Bach Pack*. As prescribed earlier by the clients, the components must be contained within the shipping container. The use of a scale model (Figure 28) assisted with configuring the components within the interior space.

Configuring the back-up generator and the batteries was important as they are components that require user interaction, therefore affecting the overall user experience of the *Bach Pack* system. Figure 28 is an example of testing configurations using scale models of the components within the *PAB Gen-2*. The batteries need to be placed in a well ventilated space due to their off-gassing whilst charging. Interior space and storage within the *PAB Gen-2* is limited therefore the project team decided the most effective way of storing the components was in one specifically designated area (as seen in the final design, section 8.0).

Figure 29 visually explains the workings of the off-the-grid system components.

Electrical system component specifications



Specifications	Solar Panel	Batteries	Solar Controller	Transformer	Generator	Efergy Meter
						
Product Name	Mitsubishi Electric PV - MF100EC4	Exide RP12/200	Outback FlexMax80	Transformer/Rectifier	Honda EU2000i	E-Reader
Number Required	4	4	1	1	1	1
Dimensions w x d x h (mm)	646 × 1425 × 56	518 × 276 × 242	140 × 40 × 100	300 × 300 × 50	290 × 510 × 425	100 × 80 × 20
Power (Collected/ Output)	100W collected per panel	n/a	n/a	n/a	2kW	n/a
Lifespan	30 years	3-10 yrs depending on maintenance	10-20yrs	10-20yrs	7-8yrs: (4yr warranty)	20yrs
Retail Outlet	Eco Innovation	Eco Innovation	Eco Innovation	Eco Innovation	NZero Technologies	Eco Innovation
Price (\$NZ)	\$1,000/panel	\$600/battery	\$1,200	\$750	\$1,600	\$100
Additional Info:	11.5kg/panel Corrosion resistant	66kg	64 days data logging 5.6kg	n/a	n/a	n/a
Electrical System Component Cost	\$10,050 (approx.) + gas califont and gas bottle					

Table 9. Electrical system components (Bowie, 2009).

To run the following:

ELECTRICITY APPLIANCES:



GAS APPLIANCES:



The following system components are required:



Table 10. Energy system overview (Bowie, 2009).

5.3 Site Visits & Semi-Structured Interviews

Aim

To investigate existing solar arrays, associated components and the design issues and user interaction involved with setting up and maintaining solar systems.

Objective

To visit sites utilising solar energy as the main energy provider and to discuss design issues with residents.

Discussion & Results

The following sites were observed:

- *Eco Innovation:* New Plymouth, Taranaki
- *The King's:* Carterton, Wairarapa
- *Tent City:* Ruakaka Bay, Queen Charlotte Sounds
- *The Links:* Koromiko, Marlborough

The four sites ranged between an isolated off-the-grid home, to residential off-the-grid homes. Each site provided useful insights into diverse contexts, system set-ups and the varying levels of user interaction involved in the set-up and maintenance of each system.

Semi-structured interviews were conducted in conjunction with each site visit and allowed for exploration into the well-established off-the-grid properties whilst simultaneously inquiring about the specifics of what the PAB Gen-2 solar system should achieve.

The sites had one distinctive relationship being that all residents had practical occupations and skills ranging from a builder and joiner to a renewable energy

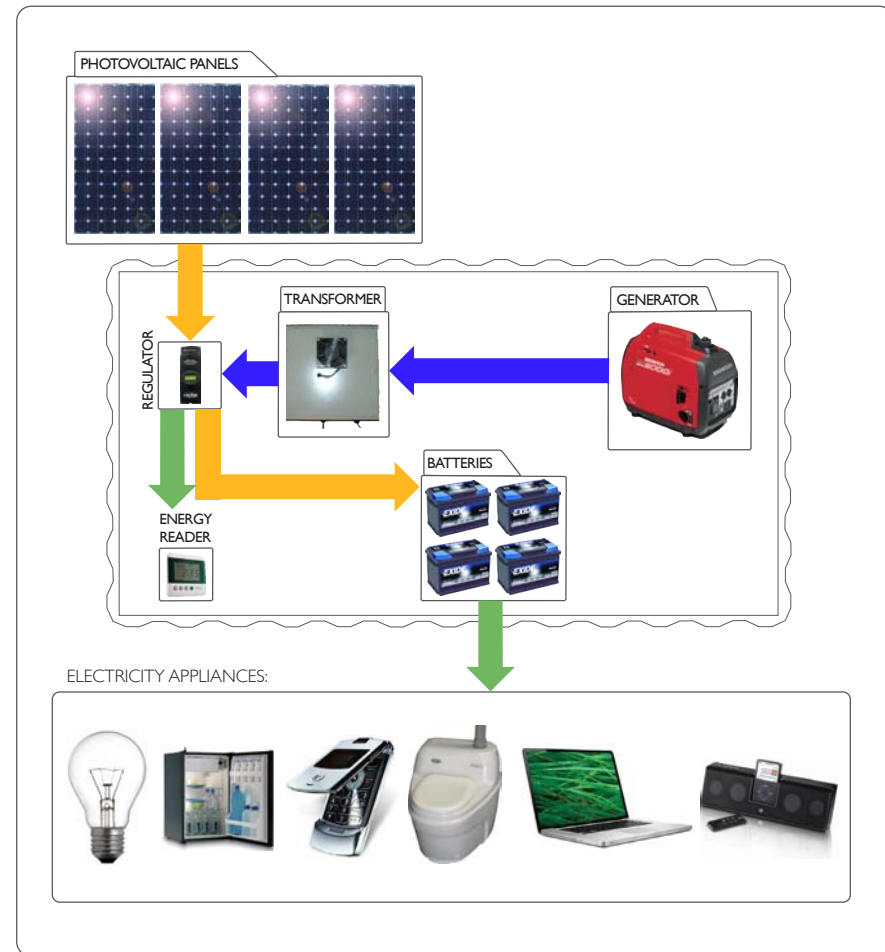

Figure 29. Off-the-grid System diagram (Bowie, 2009).



Figure 30. Solar arrays encountered on site visits (Bowie, 2009).

engineer and were therefore able to install and assemble the necessary components and structures with ease. This could be looked upon as a limitation however these residents were able to offer first-hand knowledge concerning areas likely to cause difficulty for those less familiar with renewable energy technologies, particularly solar panels.

Areas discussed included:

- Component configuration and interdependence
- Associated structures and materials
- Difficulties encountered with overall set-up and maintenance

The following common findings were identified regarding the solar arrays viewed (Figure 30):

- System component configuration included consideration of and catered for inclement weather. This affected systems by requiring adequate storage of solar energy which in turn affected the number of batteries required.
- Solar arrays were constructed by practical individuals.
- Aesthetics and integration of the overall solar array into the existing dwelling was largely not a concern. Greater significance was placed on security of the solar panels and where possible, utilising existing fixings, fastenings and structural parts which in turn dictated the overall aesthetic.
- Materials used for the solar array structure included metal and wood – often off-cuts from other 'side' projects were used.
- The most common difficulty encountered was the initial set-up of the system, including the solar array structure. Electrical and practical knowledge was required in order to complete a satisfactory system set-up. Three of the sites required external assistance to complete the technical configuration.

- Other difficulties experienced included finding an appropriate position in which to locate the solar array so that it gained maximum sunlight.

Site visit solar array advantages:

- Materials used to build the solar arrays were utilised for durability. The materials ensure a reliable, robust structure.
- Solar arrays were positioned on each site to gain maximum sunlight.

Site visit solar array disadvantages:

- Structures could not be constructed without a high level of practical skill and knowledge.
- Structures are labour intensive to build as they must be constructed specifically for each site.
- Most solar array structures were obtrusive and did not integrate suitably with surroundings.

The following common findings were identified regarding the requisite system components (*Figure 31*):

- All were stored in independent housings from the main dwelling. This was due to spatial requirements and was often incorporated into storage spaces such as sheds or garages which were easily accessible.
- Independent housing was indiscreet namely due to the size of the system and subsequent components required.
- Batteries were inspected daily while dwellings were occupied and topped up with water when hydrometer was below the fixed marker.



Figure 31. Site visit system component configuration examples (Bowie, 2009)

Site visit system components advantages:

- Separation of the components from the main dwellings ensures safe containment of technologies and enables easy access when maintenance is required.

Site visit system component disadvantages:

- All require a number of devices to enable the system to run sufficiently, therefore a substantial amount of space is required to store the components.
- Require electricians to configure the systems.

The most useful information gained concerning the overall solar system was with regards to the construction and user interaction required with the set-up and maintenance of each of the system components. This information was translated into design criteria (*Chapter 6*) relevant to the *PAB Gen-2* and used to inform the design of the *Bach Pack*.

5.4 Solar System Research Conclusion

In summary of the research carried out prior to the creative design phase, the following points are noted with regards to the *PAB Gen-2*:

- The amount of power required to run the electrical appliances is 3.13 AC kW hrs/week.
- The solar panels require mounting and connection by the homeowner.
- The associated components of the solar system require storage within the confines of the *PAB Gen-2*.
- The gas califont and gas bottle require mounting and connection by the homeowner.
- The system will be 12V.

The analysis and inquiry pursued as research *for* design was critical to this project as it laid the foundations for the second phase, research *through* design. Investigations in the initial research highlighted the general 'ad-hoc' nature of solar array frames and the relative high skill level required. These attributes were carried into the research *through* design phase as food for thought.

Chapter Six Solar Array Design Criteria

6.0 Criteria Overview

Criteria were drawn from considerations noted during the context review as well as from the results gained for the solar system investigation (*Chapter 5.0*). Key criteria were developed and divided into performance and experience criteria (*Tables 11-14*). Each criterion was rated as to its level of desirability for the product outcome.

6.1 Performance design criteria

Criteria		Required	Desirable (High)	Desirable (Moderate)	Desirable (Low)
Solar System	Components required to enable the 3.13 AC kW hrs/week system (section 5.2) should be stored within the confines of the PAB Gen-2.	○			
	System components should be accessed with ease by the homeowner		○		
	The Bach Pack should run off a 12V system	○			
Energy Efficiency	Array must hold four solar panels	○			
	Ability to rotate 360 degrees	○			
	Adjustable angle tilt of panels to maximise summer and winter sun				○
	The performance involved in the assembly of the Bach Pack stimulates and encourages discussion surrounding self-sufficiency			○	
Adaptability	Array must attach and detach to existing shipping container shell without permanent fixtures	○			
	Array can be erected on any unoccupied corner of any shipping container		○		
	Wind turbine can be integrated or otherwise can utilise the same components as the array			○	

Table 11. Performance design criteria – Part one (Bowie, 2009).

Criteria		Required	Desirable (High)	Desirable (Moderate)	Desirable (Low)
Assembly	Electrical configuration executed during PAB Gen-2 construction requiring homeowner to simply 'plug in' the Bach Pack to the dwelling to enable the system		○		
	Maximum of 2 individuals with a low level of practical skill and knowledge are required to set up the Bach Pack		○		
	Manual design features should be incorporated where possible		○		
Safety	Secure, safe mounting of panels and theft consideration		○		
Manufacturing, Commercial Viability & Cost	Minimal number of parts		○		
	Unified connection system		○		
	Use of existing 'mature' technologies		○		
	Use of existing OEM parts and materials where possible		○		

Table 12. Performance design criteria – Part two (Bowie, 2009).

6.2 Experience design criteria

Criteria		Required	Desirable (High)	Desirable (Moderate)	Desirable (Low)
Assembly	Assembly of array must induce an engaging, pleasurable and intuitive experience		<input type="radio"/>		
	Product borrows principles that resemble previously 'known' activities to reference assembly & deployment of array		<input type="radio"/>		
	The assembly involved in the set up of the Bach Pack should evoke leisure activity qualities		<input type="radio"/>		
	Unified assembly procedure: same part can be used throughout Port-a-Bach Gen-2			<input type="radio"/>	
	Touch points are coloured to visually highlight areas that require manual adjustment		<input type="radio"/>		
	Touch points use texture to indicate areas that require hands-on fastening		<input type="radio"/>		
	Visual references/symbols should ensure validation for the end user when parts are correctly aligned		<input type="radio"/>		
	Risk & error management considered and incorporated into design		<input type="radio"/>		
	Sense of reward and satisfaction both throughout assembly and upon completion		<input type="radio"/>		

Table 13. Experience design criteria – Part one (Bowie, 2009).

Criteria		Required	Desirable (High)	Desirable (Moderate)	Desirable (Low)
Assembly	Array can be erected with minimal practical knowledge and easily comprehended		○		
	Illustrative diagrams included and used to aid a positive assembly process		○		
	Bach Pack provides a sense of reliability and security once assembled		○		
Context	The Bach Pack is a statement identifying homeowners as individuals whom carry an interest in and concern for self-sufficiency and sustainability		○		
	Bach Pack does not compromise the aesthetic integrity of the shipping container and overall dwelling as a 'bach' and place of relaxation		○		
	Aesthetic compliments and references the robust, reliable shipping container aesthetic.		○		
	Array induces a dignified sense of gratification as an additional module to PAB Gen-2		○		
Safety	Product in no way endangers the user if installed correctly and instructions followed	○			

Table 14. Experience design criteria – Part two (Bowie, 2009).

Chapter Seven Solar Array Creative Investigation

7.0 Research through Design Overview

This section describes and discusses results from the creative investigation undertaken. The aim of this section was to generate experimental concepts for the solar array using the performance and experience criteria outlined in *Chapter 6.0*. A range of eight creative strategies were implemented in order to develop the *Bach Pack* design. The concept work involved in this chapter builds on information gathered regarding the specification of components for the independent energy system.

7.1 Ideation & Concept Sketching

Aim

To initiate creative exploration through the use of sketching in a conceptual manner.

Objective

Establish a range of imaginative solar array concepts loosely based on the performance and experience design criteria.

Outcome

- The need to establish the location of the solar array.

Discussion

The ideation phase was a useful method that built on previous research findings. The nature of many of the drawings was futuristic and not an attempt to design the final product. The paper strip was a successful brainstorming technique in engaging the researcher with the creative design phase. It became difficult however to focus on the design of the array due to one critical factor that required resolution prior to progressing with the design work; the location of the solar array.

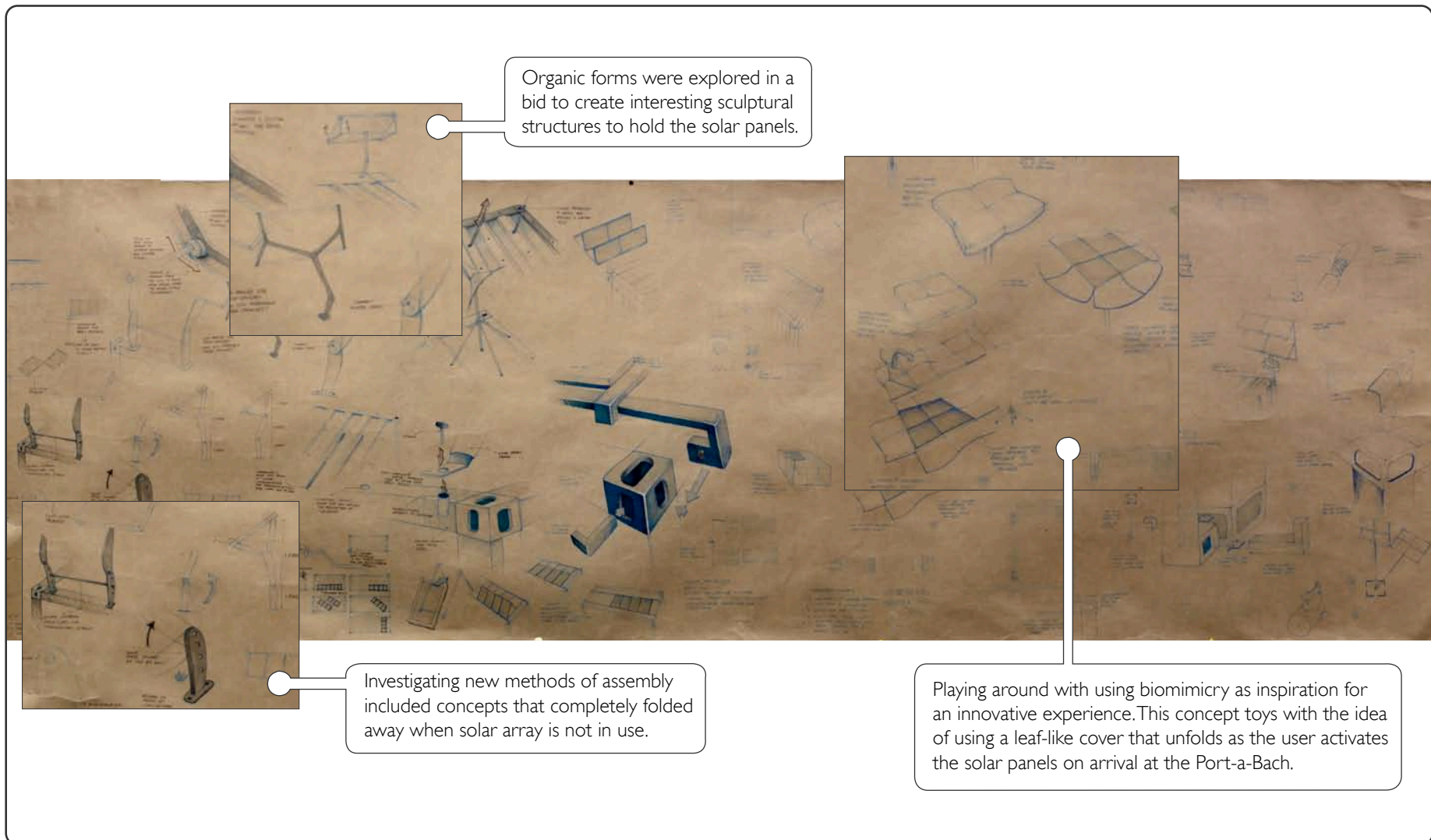

Figure 32 Early conceptual investigation (Bowie, 2009).

7.2 Scale Model & Concept Development

Aim

To establish the location of the solar array.

Objective

Produce storyboard scenarios using a scale model to investigate concepts for the solar array location and related assembly via step-by-step photographs. Explore the location options and issues presented by each concept.

Outcome

- Selection of 'Raise the Array' concept (Table 16, further explained in Figure 37). This concept was based on the use of a mast that connected to the standard shipping container corners.

Discussion

A series of concepts for various locations (Figure 34) were sketched and the four most successful selected for storyboarding through the use of scale models. Further storyboard concepts can be viewed in Appendix 11.11.

The concepts were evaluated using a matrix (Table 15) which initially rated the rooftop array as the best location for the solar panels. Upon further research, the rooftop proved to be a problematic location to fix panels due to the following issues:

- Universal rooftop attachments would be required to allow the solar array to face any direction due to site variation with relation to the sun. For stationary fixings this would mean providing a multitude of potential fixing locations to provide many possible angles for attachment and therefore unused fixings would be redundant.

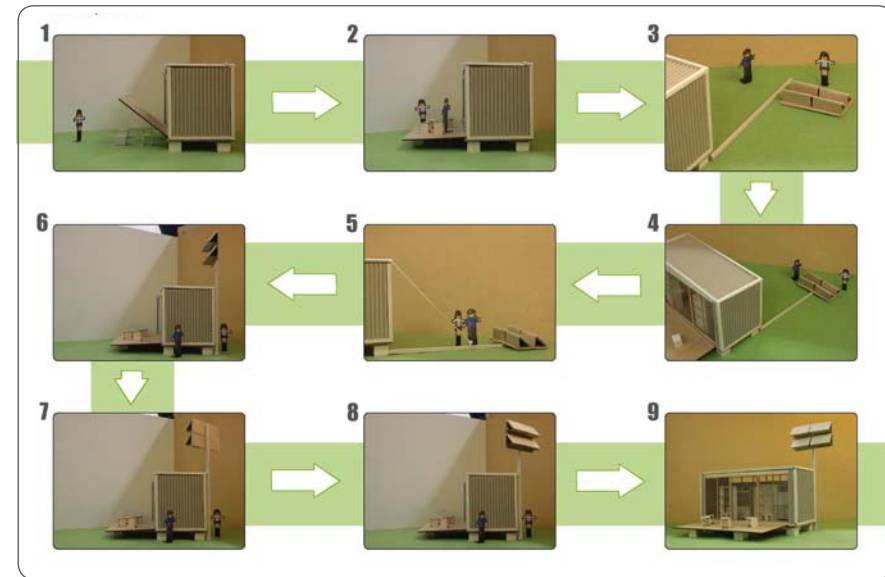

Figure 33. Storyboard of solar array 'Winch' concept (Bowie, 2009).

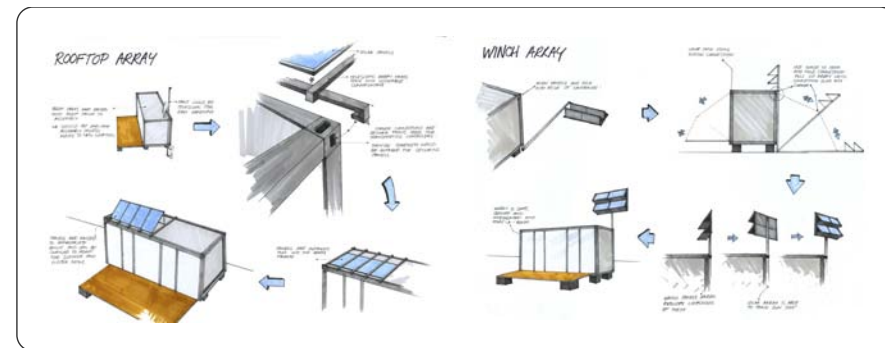

Figure 34. Solar panel location concepts (Bowie, 2009).

Solar panel location matrix





Selection Criteria	Weight	Winch Array		Rooftop Array		Concertina Wallmount		Gas-sprung Pole	
									
		Details	R/WS	Details	R/WS	Details	R/WS	Details	R/WS
Energy Efficiency	40								
Gains maximum sunlight	25	High sunlight exposure	25 625	High sunlight exposure: possible shadow problem	18 450	High sunlight exposure	25 625	High sunlight exposure: possible shadow problem	18 450
Can rotate to track sun	15	Yes - 360°	15 225	Yes - 360°	15 225	Function can be designed	13 195	No	0 0
Location	30								
Mounted array integrates into overall aesthetic	10	Good - out of way	8 80	Good - out of way	8 80	Good - out of way	10 100	Average - sticks out side of container	5 50
Uses strength of container for stability	10	Average	5 50	Average	5 50	Good strong use of existing stability points	10 100	Bad - strength required by attachments for frame	2 20
Consideration of theft	10	Good	8 80	Good	8 80	Good	9 90	Average - depends on security of attachment fixings	5 180
Manufacture	15								
Few parts required	15	Good - frame and pole	12 180	Good - frame and pole	12 180	Good - frame	13 195	Good - frame and attachment fixings	12 180
User experience	15								
Minimal lifting required for assembly	15	Average: panels, frame, pole	7 105	Good - uses winch	12 180	Good - one time installation	13 130	Average - lifting frame and panels onto container side	8 105
Total Score	100		1345		1245		1435		855
Rank			2		3		1		4

Table 15. Solar panel location matrix (Bowie, 2009).

- ISO constraints (*Section 1.4*) allow for no protruding parts.
- Users were required to climb on top of the container, exposing them to additional health and safety risks.
- Attachment required fixings to pierce the container skin, jeopardising its waterproof integrity.
- Attachment required multiple parts (including a number of smaller parts) for assembly, complicating the overall user experience.

This research accentuated the problems faced with fixing solar panels to the roof. Additional concepts produced more viable solutions for fastening and attachment of solar panels and were presented to the clients with their corresponding strengths and weaknesses as shown in *Table 16*.

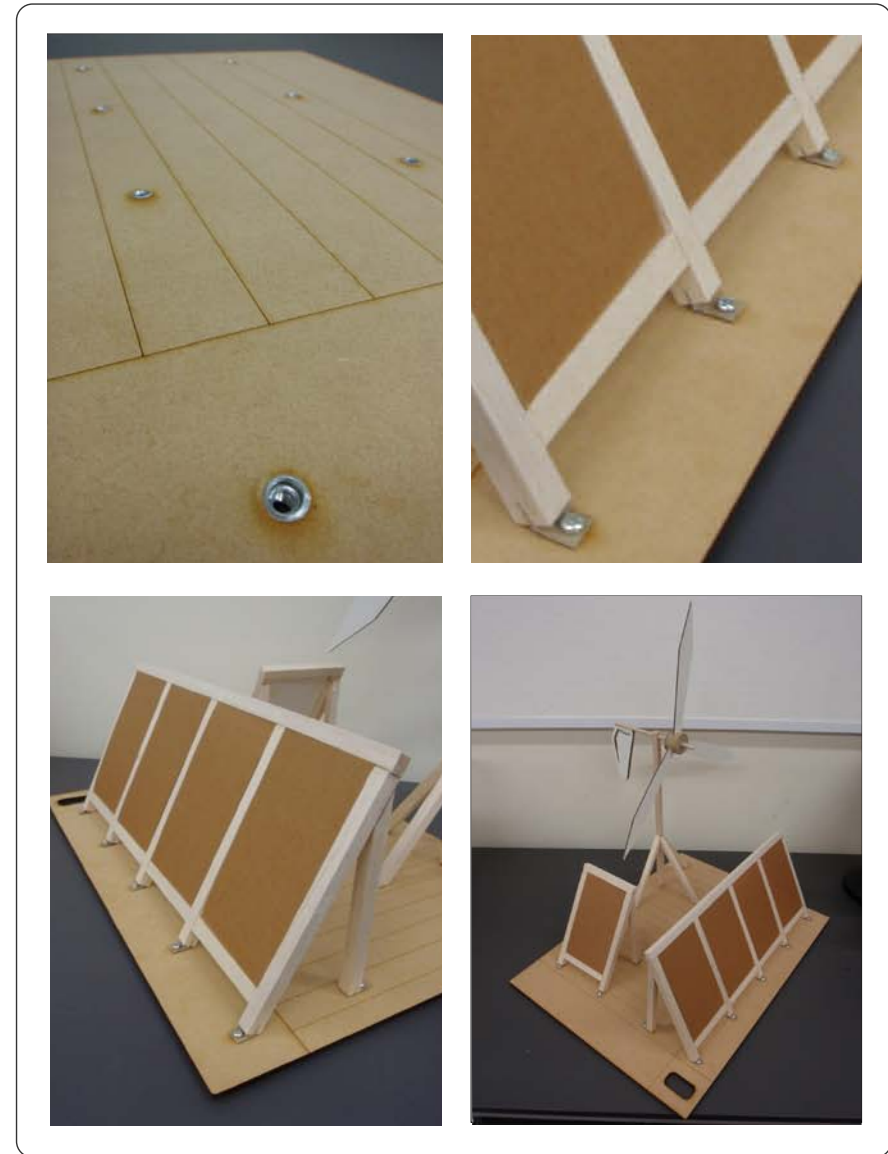

Figure 35. Rivnut rooftop fastening investigation (Bowie, 2009).

Solar panel location pro's vs con's





	Concertina Wallmount	Articulated Arm	Welcome Bach	Indoor/ Outdoor flow	Raise the Array
					
	Pro's vs Con's	Pro's vs Con's	Pro's vs Con's	Pro's vs Con's	Pro's vs Con's
Energy Efficiency	<ul style="list-style-type: none"> + Can be assembled N,E,S,W - Fixed position so does not gain maximum sunlight possible 	<ul style="list-style-type: none"> + Can be assembled N,E,S,W + Allows for tilt adjustment for summer and winter - Fixed position = no tracking 	<ul style="list-style-type: none"> - Only assembled on N face - Fixed position so does not gain maximum possible sunlight 	<ul style="list-style-type: none"> + Can be assembled N,E,S,W - Fixed position so does not gain maximum possible sunlight 	<ul style="list-style-type: none"> + 360° tracking of the sun + Manual tracking
User experience	<ul style="list-style-type: none"> + Panels expand by gliding over rail with ease - User must get onto roof to adjust angle of panels 	<ul style="list-style-type: none"> - User must get onto roof to adjust angle of panels - 2 people to assemble - Lifting required onto roof 	<ul style="list-style-type: none"> + No lifting required - User must get onto roof to lock panels into place - What happens if wire breaks? 	<ul style="list-style-type: none"> + Few parts required + Universal attachment for both interior and exterior - User must get onto roof to attach and adjust tilt 	<ul style="list-style-type: none"> + No lifting + Uses manual mechanism principles already familiar + Specific attachment designed for shipping containers
Function	<ul style="list-style-type: none"> + Panels use strength of container for stability + Consatina keeps panels together securely - Rail must allow for both horizontal and vertical movement - User must get onto roof to enable assembly of array 	<ul style="list-style-type: none"> + Articulated arm folds away for storage + Modular connections - Many moveable parts - Panels assembled individually - Stored separately for storage - Entire frame must be shifted for each location 	<ul style="list-style-type: none"> + Frame holds panels secure + Ability to adjust for summer and winter sun + Panels can lie flat: easy for transportation - Ratio between deck:panels would differ depending on location: not universal 	<ul style="list-style-type: none"> + Ability for modularity + Panels secured together for strength - Not considered for wind turbine attachment 	<ul style="list-style-type: none"> + Modular: more panels: can attach wind turbine to same structure + Uses strength of container for stability + Does not pierce container skin: waterproof + Can use revised versions of existing technology
Aesthetics	<ul style="list-style-type: none"> - Cover can be utilised to cover panels however this hinders their purpose 	<ul style="list-style-type: none"> - Panels laid upside down to assemble: fragile + Interesting, new aesthetic 	<ul style="list-style-type: none"> - Not an innovative or interesting aesthetic 	<ul style="list-style-type: none"> - Not entirely new concept 	<ul style="list-style-type: none"> + Requires minimal additional new materials + Frees up roof for other uses

Table 16. Solar panel array location pro's vs con's (Bowie, 2009).

7.3 Concept Development & Storyboarding

Aim

Generate and explore solar mast concepts based on the 'Raise the Array' concept.

Objective

Draw out concept scenarios involving the assembly and deployment of the solar mast based on the performance and experience criteria.

Outcome

The 'Raise the Array' concept required three critical design elements:

- 1 *Base connection:* A fixing that provides strength by locking to the container corners and allowing for the mast connection.
- 2 *Mast:* A mechanism that can attach to the base connection whilst allowing for the connection, raising and lowering of the array frame.
- 3 *Array frame:* A structure that fastens the solar panels together in a secure manner and attaches to the mast.

Discussion

A number of concepts were generated and looked specifically at the deployment of a mast. Issues included:

- Stabilising the mast: This requires a robust fixing that would hold the mast against the container and prevent movement.
- Fixing the mast to the container corner. This needs to be done on arrival by the users therefore must be a simple intuitive mechanism.
- Raising the mast from the ground to the container. A winch is used to lower the deck on the front side of the PAB, however it sits in the centre

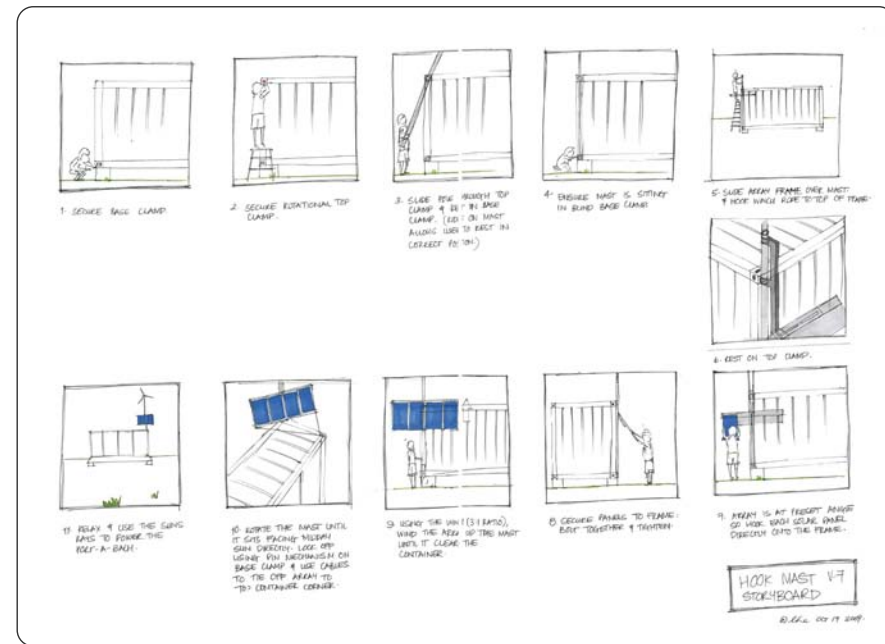

Figure 36. Concept storyboard (Bowie, 2009).

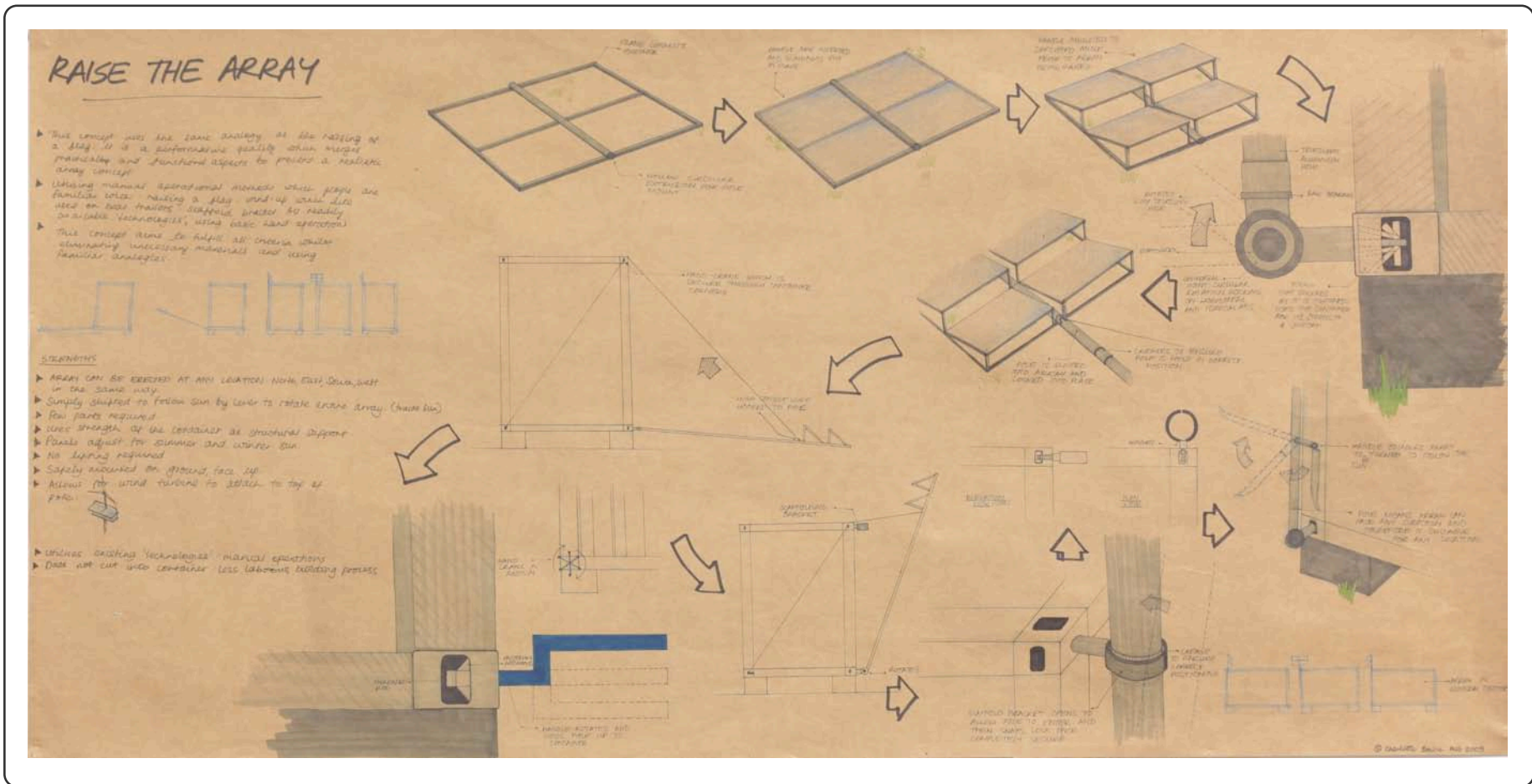

Figure 37. Raise the array: solar mast concept (Bowie, 2009).

of the container and would require the attachment of guides on the top of the container in order to utilise it.

- Attachment of solar panels. This ideally would be done at ground level and separate the panels from the frame so that each component is manageable.

At this stage it was useful to utilise the PPE framework to engage with experiential qualities that could be provided by the *Bach Pack*. The concept 'Raise the Array' was used to try to link with segments of the framework (Figure 38). Specifically, it was useful to consider the recognition and comprehension qualities. For example, could the solar panels be raised in the same way that a person raises a flag? This is a familiar, easily identified and understood activity. These are the attributes which the *Bach Pack* must include for the product to engage with the wider audience of end users with basic practical skills.

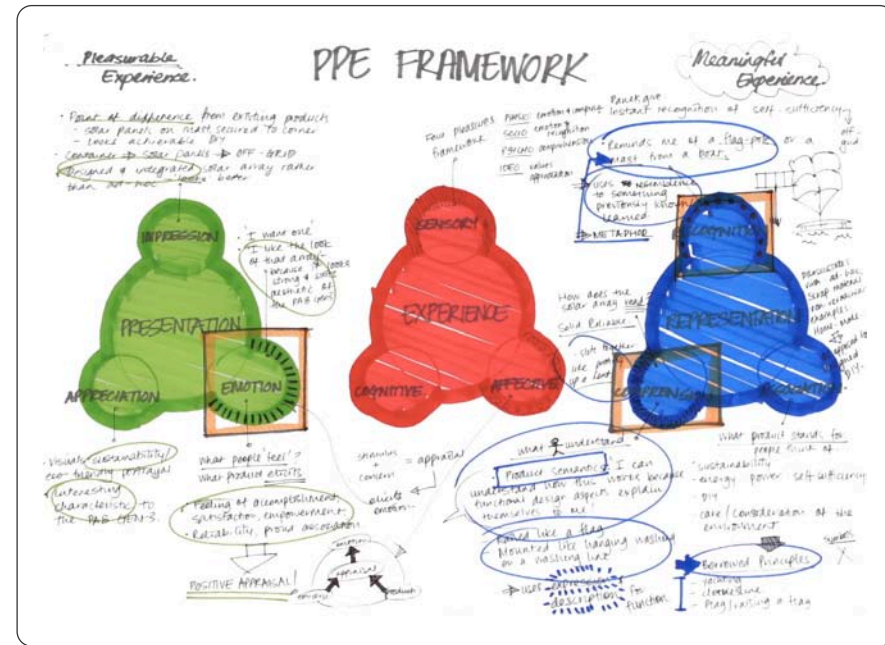

Figure 38. Using the perceptual product experience framework for *Bach Pack* design considerations (Bowie, 2009).

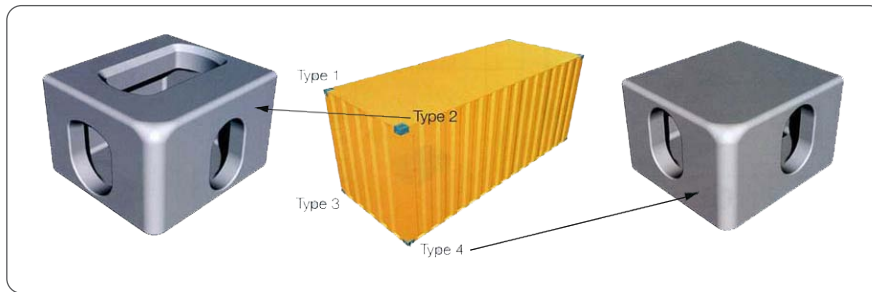

Figure 39. Container corner castings (Pacific Marine & Industrial, n.d).

7.4 Iterative Concept Development

Aim

To develop the three essential components of the solar array mast (base connection, mast and array frame, *section 7.3*) into a unified design that satisfies most design criteria.

Objective

Develop and refine the components of the solar array mast against the performance and experience design criteria. Utilise models in conjunction with drawings to improve on the functional characteristics and apply known activities to the assembly and deployment of the mast.

Discussion

The iterative stage of the creative investigation took the most time and produced the most significant output of design work.

The solar array mast contains three dominant components, each reliant on the other. For this reason, the three components were worked on simultaneously in order to achieve a unified design.

7.4.1 Iterative development: base connection

Aim

To develop a base connection that clamps to standard shipping container corners (*Figure 39*) and allows for sub-attachment of a mast.

Objective

Develop a concept to the stage whereby it can be made into a prototype and tested by users.

Base Connection Outcome

The base connection selected was the 'Front Twist Cap & Lock' concept based on a quarter-turn fastening mechanism. The concept merged the benefits of the prototypes fulfilling most of the criteria outlined in *Table 17*. In addition, the rear end of the internal fitting is designed to enable the front attachment to rotate at increments of 45°. This enables the connection to be utilised for the solar array mast and potentially as a means to support water harvesting pipes.

The 'Front Twist Cap & Lock' connection was developed further throughout the iterative process and is illustrated in the following research section (*section 7.4.2*) where specific attention was paid to product semantics and development of surface textures, form and the integration of visual confirmation features.

Discussion

The design of the base connection was crucial to the overall development of the mast and array frame. Shipping container corners are exceedingly robust and are used as a means to 'lock down' the container onto trains, trucks and ships. With this kind of durability in mind, it made sense to appropriate them for the use of a solar mast. The benefits of designing a base connection included:

- The universal nature of the connection: all containers have the same corner parts cast and welded to the frame.
- Use of corners fulfills concerns regarding strength.
- A base connection could provide options for further attachments required (i.e. water harvesting system or a shade awning).

Early investigation into truck connections to shipping containers was undertaken which was useful in terms of understanding the type of connection required to hold such a load (*Figure 40*). Truck connections resist movement horizontally by



Figure 40. Truck connection for shipping containers (Bowie, 2009).

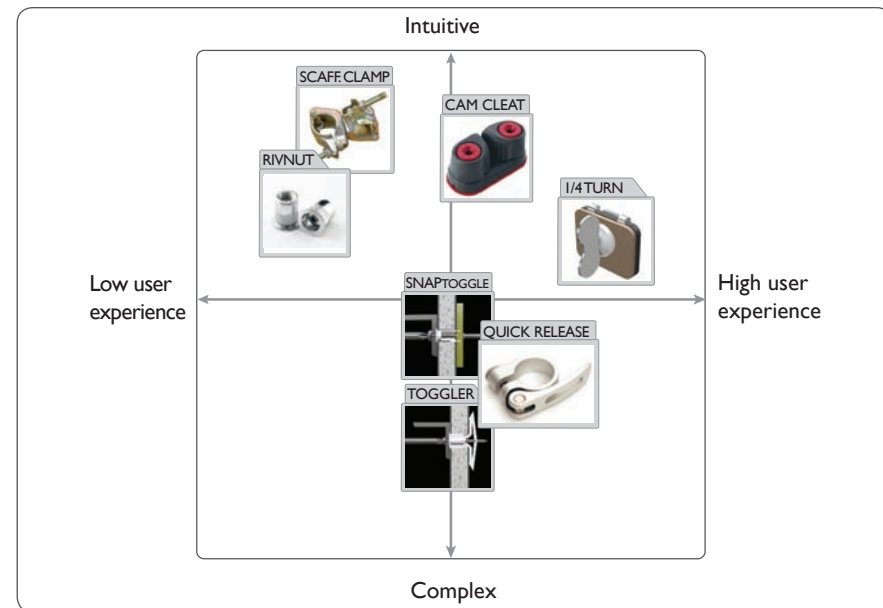

Figure 41. Fastener analysis (Bowie, 2009).

Base connection matrix





		Spanner Crank		Rear Groove		Front Loader		Pin Lock	
									
Selection Criteria	Weight	Specification	R/WS	Specification	R/WS	Specification	R/WS	Specification	R/WS
User experience	38								
Simple, intuitive procedure	8	Common tools required	3 24	Average	4 32	Good clear process	8 64	Poor	2 16
Minimal individual parts	6	All parts joined together	4 24	Good	6 36	All parts joined together	6 36	All parts joined together	4 24
Visual indication of correct placement/orientation	7	No visual indication	2 14	Good clear indication	7 49	Average visual indication	5 35	Average visual indication	2 14
Pleasurable, satisfying product experience - sense of reward	8	Poor	2 16	Average	4 32	Average	6 48	Poor	5 35
Connection will only work one way allowing no mishandling	9	Poor - can still connect even when not in correct position	2 18	Poor - can still connect even when not in correct position	2 18	Average - can still connect when not in correct position	6 54	Good - can only connect in one position	9 81
Function	30								
Adaptable: can be used on any container corner	8	Yes	8 64	Yes	8 64	Yes	8 64	Yes	8 64
Connection is easily removed/released	7	Average	4 28	Average	3 21	Average	7 49	Poor	4 28
Integration of connection allowing attachment of mast	15	Average	7 105	Poor	4 60	Average	11 165	Poor	0 0
Manufacturing, Commercial Viability & Cost	20								
Use of existing technologies/parts where possible	5	Poor	2 10	Poor	2 10	Poor	2 10	Average	3 15
Few custom made parts req.	5	Poor	1 5	Poor	2 10	Poor	2 10	Poor	2 10
Replaceable parts	5	Good	5 25	Good	5 25	Good	1 5	Good	5 25
Durable yet sustainably sourced materials	5	Metal - average	3 15	Metal & plastic - average	3 15	Metal & plastic - average	3 15	Metal & plastic - average	3 15
Aesthetic Context	12								
Ties seamlessly with industrial, rigid, reliable aesthetic	12	Average	6 72	Average	5 60	Average	6 72	Poor	3 36
Rank	Total Score		6 420		5 432		3 627		7 363

Table 17. Base connection concept scoring matrix – Part one (Bowie, 2009).

Base connection matrix



		Cam Lock		Fixed Front Mechanism		Front Twist Cap & Lock				
										
Selection Criteria	Weight	Specification	R/WS		Specification	R/WS				
User experience	38									
Simple, intuitive procedure	8	Average - parts must be in line	5	40	Good	6	48	Good, clear process	8	64
Minimal individual parts	6	All parts joined together	6	36	Good	6	36	All parts joined together	6	36
Visual indication of correct placement/orientation	7	Cam used as visual indication	7	49	Part used as visual indication	7	49	Clear visual indication	7	49
Pleasurable, satisfying product experience - sense of reward	8	Good	7	56	Good	7	56	Good	8	64
Connection will only work one way allowing no mishandling	9	Good - cam acts as visual indicator telling user when connection in place	7	63	Good - part acts as visual indicator telling user when in place	7	63	Good - front cap allows user to see when in correct position	8	72
Function	30									
Adaptable: can be used on any container corner	8	Yes	8	64	Yes	8	64	Yes	8	64
Connection is easily removed/released	7	Average	6	42	Good	6	42	Good	6	42
Integration of connection allowing attachment of mast	15	Average; only for solar mast, not designed to take variety of parts	7	105	So long as same thread diameter	12	180	So long as same thread diameter	12	180
Manufacturing, Commercial Viability & Cost	20									
Use of existing technologies/parts where possible	5	Poor	2	10	Average	4	20	Average	4	20
Few custom made parts req.	5	Poor	1	5	Average	3	15	Average	3	15
Replaceable parts	5	Good	5	25	Good	5	25	Good	5	25
Durable yet sustainably sourced materials	5	Metal - average	3	15	Metal & plastic - average	3	15	Metal & plastic - average	3	15
Aesthetic Context	12									
Ties seamlessly with industrial, rigid, reliable aesthetic	12	Good	9	108	Average	8	96	Average	9	108
Rank	Total Score		4	618		2	709		1	754

Table 18. Base connection concept scoring matrix – Part two (Bowie, 2009).

Prototype investigation



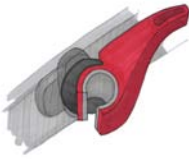







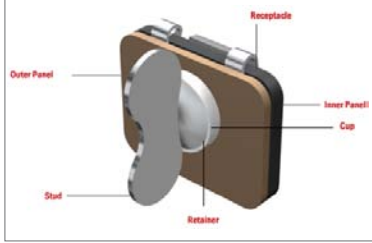



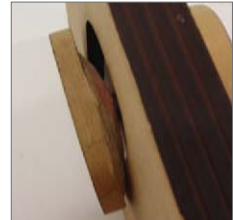

Inspiration	Prototypes	Performance Details		
<p>Quarter turn fastener:</p> 	<p>Raised rear plate with integrated front mount:</p> 			
<p>Scaffolding Clamp:</p> 	<p>Rotating front plate mechanism:</p> 			
<p>Quick release mechanism:</p> 	<p>Front face arm crank with rotational fitting:</p> 			<p>90° visual indicator:</p> 
				

Figure 43. Prototyping base connection concepts (Bowie, 2009).

Prototype Investigation

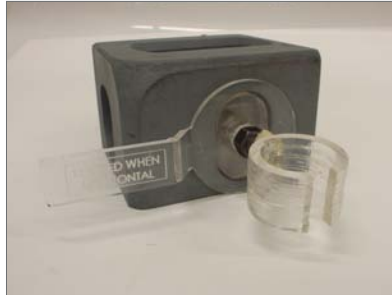
Front handle rotation mechanism with adjustable clamp angle:

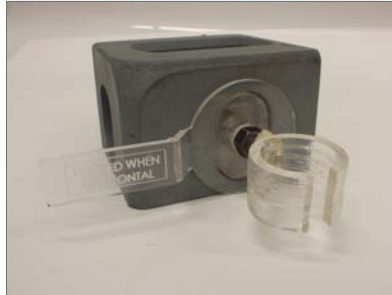

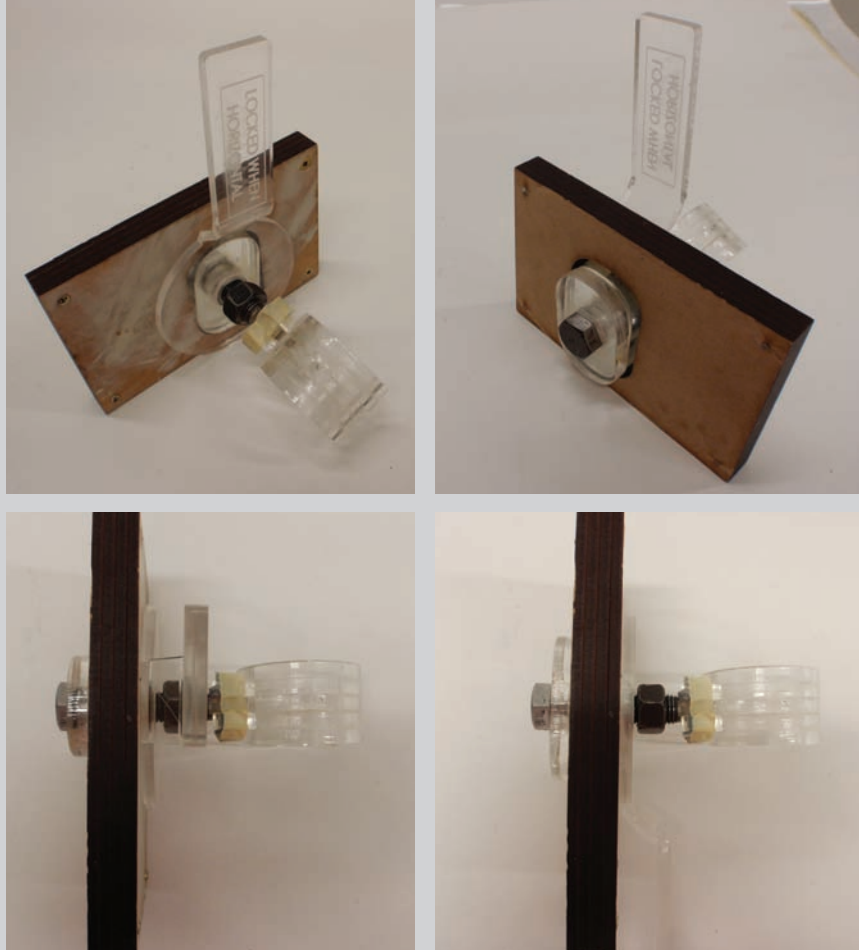
Metal clamp with removable front clamp:

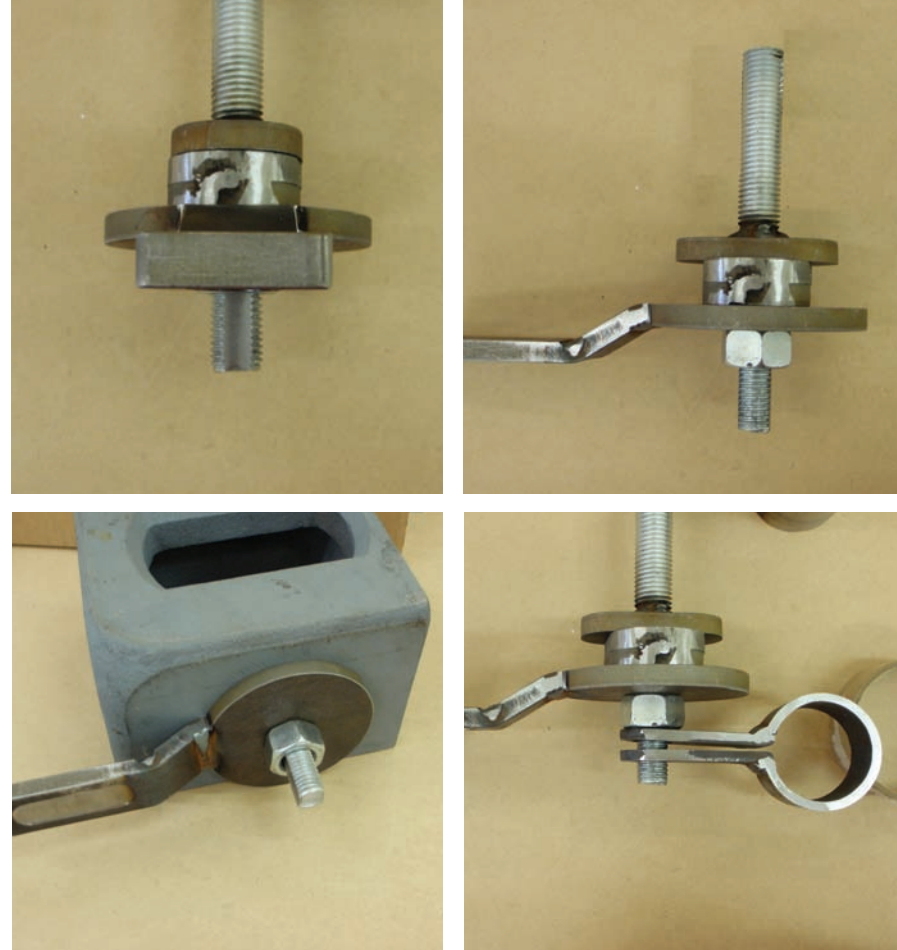

Figure 44. Base connection prototype development (Bowie, 2009).

using a quarter-turn fastener. The difference was that the connection for the *Bach Pack* required resistance both horizontally and vertically as well as allowing for an external sub-attachment of the mast.

Inspiration was gained by investigating a variety of existing fasteners and self-locking mechanisms (*Figure 43*) including scaffolding clamps, quarter-turn fasteners and cam-lock mechanisms. The quarter-turn fastener displayed the same qualities desired in the base connection: a simple 90° rotation, enabling a clamp effect.

Shipping container corners are cast therefore presenting the issue of tolerance. This was explored through the investigation and use of sprung steel, springs and threaded rod (*Figures 43 & 44*).

The design of the base connection was explored through the simultaneous use of concept sketching (*Figure 42*) and model making (*Figures 43-44*). Models assisted in refining technical details that could not be explored in two dimensions.

7.4.2 Iterative development: mast & solar array frame

Aim

To develop an integrated mast and array frame that connects to the base connection.

Objective

Develop a mast and array frame that considers the criteria affecting the performance qualities as well as the end user experience. Utilise existing, familiar activities to describe the assembly and deployment of the components through the use of sketching and storyboarding scenarios.

Outcome

There were several outcomes of this iterative development for both the mast and the solar array frame. Outcomes of the mast development included:

- Decision to utilise scaffolding tube for the mast itself.
- Utilising an existing, proven mechanism within the scaffolding tube to raise and lower the solar array frame - a bevel pinion drive.
- Development of the mast to enable 360° rotation from ground level.

Outcomes of the solar array frame development included:

- The design of a location specific, fixed angle bracket for mounting the solar panels.
- The design of a coupling that works with the bevel pinion drive, allowing the array to be raised and lowered by the end user from ground level.
- The inclusion of stays to secure the solar array to the container once rotated to the desired position.

Discussion

The mast and array frame were designed in unison with the base connection (*section 7.4*). The benefit of using a mast for the solar array include:

- Ease of attachment and removal from the container
- Mounting the solar panels at ground level
- Raising and lowering the array from ground level
- Elimination of winch
- Use of standard parts i.e. scaffolding tube
- Modular design enabling addition of a wind turbine

Many of the concepts were developed to a stage whereby they were considered 'working' concepts however didn't satisfy some of the key criteria outlined. Areas that needed reconsideration included the choice of mechanisms and components that required custom-made parts. The design of the mast was explored through marker renderings formed into step-by-step storyboard scenarios. The storyboards simulated the user assembly and experience and enabled potential hazards and design issues to be recognised and subsequently dealt with.

A series of methods of raising and lowering the array were investigated. Inspiration was gained by exploring familiar concepts of raising and lowering such as raising a flag and raising sails on yachts (i.e. pulleys, *Figure 45*) along with other commonly used products such as the clothesline (*Figure 46*).

Several issues were encountered with mechanisms including:

- Using a pulley to raise the array past the top base connection
- The placement and security of using pulleys to raise and lower the array

The bevel pinion drive is an existing mechanism often housed within mechanical hoists (*Figure 47*). It is well regarded as a robust, reliable mechanism. In this context, the mechanism works by using two right angled pinion gears to drive a screw which raises and lowers the coupling that the array is mounted to. An example of the mechanism used in clotheslines is illustrated in *Figure 48*.

Issues encountered with the array frame included:

- The use of a versatile bracket mount allowing for tilt adjustment of the solar panels
- The specification of an existing mechanism enabling the attachment of the array frame to the mast and allowing it to be raised and lowered



Figure 45. Methods of raising and lowering sails and flags (Bowie, 2010).



Figure 46. Collapsible clothesline (Bowie, 2010).



Figure 47. Mechanical hoist (Bowie, 2010).

- Incorporating struts to secure and stabilise the array frame
- Rotating the array following attachment of the solar frame and panels

The design of a location specific, fixed bracket mount for the solar panels was a decision deemed beneficial by the project team. The reduction of moving parts allows for a more robust, dependable system whilst also eliminating a potentially confusing section of the assembly process for the end user (Figures 49 & 50).

Investigation into the use of an existing yachting product was the 'traveller' (Figure 49). These are used on yachts to raise and lower the sails and are expensive, highly detailed components designed for high-use. The specification of a traveller in this context was considered extravagant by the project team.

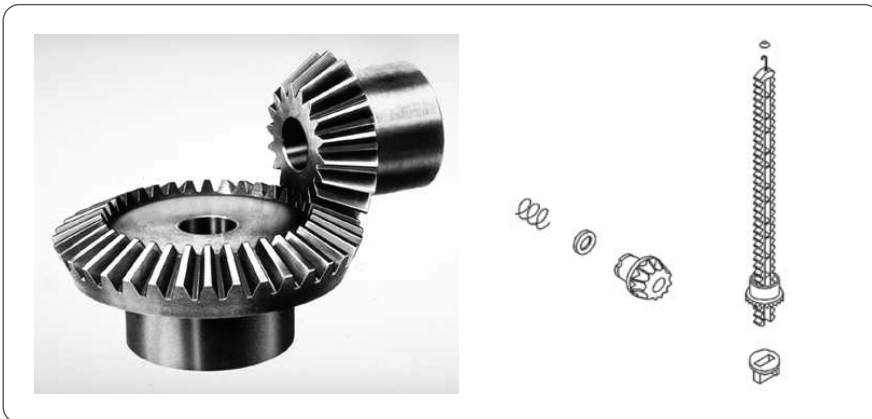
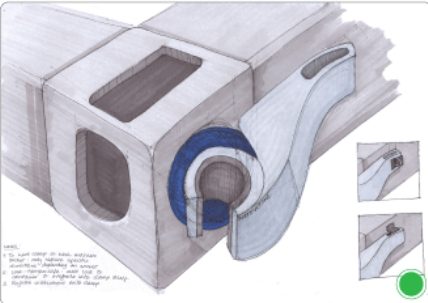

Figure 48. Bevel pinion mechanisms (Bowie, 2010).

Additional concepts further reduced the number of custom made parts and looked to specify more original equipment manufacturing (OEM).

Iterative investigation

Iterative Investigation



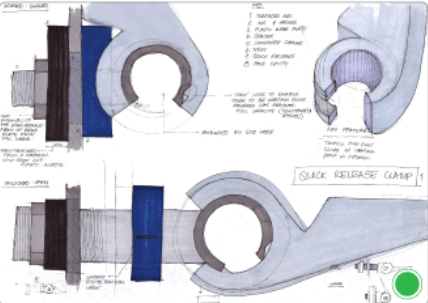

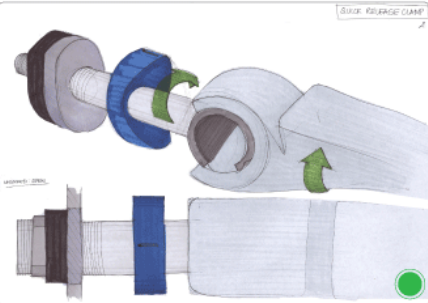

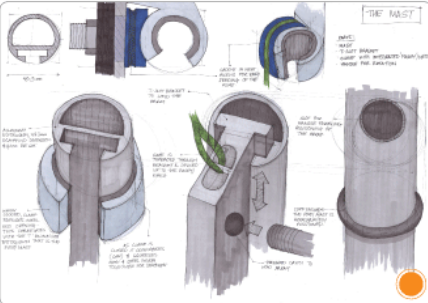

Cam-lock Concept Aim: To design a unified solar array mast that allows for a sliding bracket to raise and lower the solar panels using a winch mechanism.

Discussion:

- 1 Concept explored use of existing mechanism, cam-lock principles: tighten and lock-off.
- 2 Investigated the integration of winch placement within an extruded pole.
- 3 Angle adjustment of solar panels was considered as integrated feature on array frame bracket.
- 4 References to yachting i.e. masts, pulleys and stays were used as inspiration.

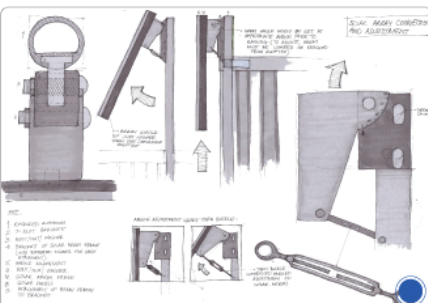

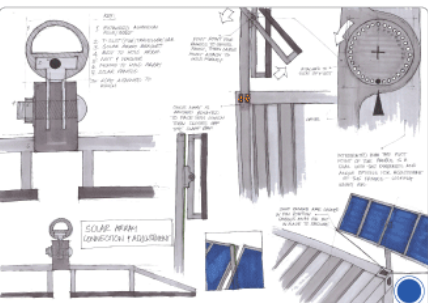

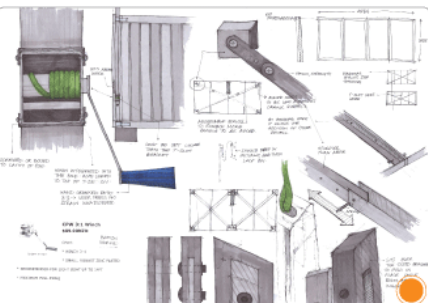

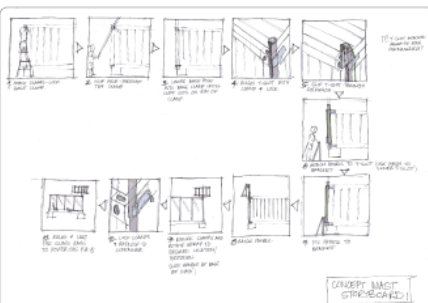

<ul style="list-style-type: none"> ● Base Connection ● Mast ● Solar Array Frame 	<ul style="list-style-type: none"> ● + Cam lock mechanism enables rear plate to turn 90° before winding the lock and engaging the cam. ● + Fastening mechanism ensures all parts are linked. ● - Break in cam lock to allow for array bracket instantly reduces the strength of the solar array mast and structure. 	<ul style="list-style-type: none"> ● + Dealing with integrated bracket and mast system, reducing number of parts the end user needs to assemble. ● + Exploring methods of angle adjustment of the solar panels for summer and winter sun using adjustment mechanisms used on boats. ● - Moving parts brings a variety of associated end user difficulties
---------------------------------------------------------------------------------------------------------------------------------------------------------------------------------------------------------------------------	---------------------------------------------------------------------------------------------------------------------------------------------------------------------------------------------------------------------------------------------------------------------------------------------------------------------------------------------------------------------------------------------------------------------------------------------------------------	----------------------------------------------------------------------------------------------------------------------------------------------------------------------------------------------------------------------------------------------------------------------------------------------------------------------------------------------------------------------------------------------------------------------------------------------------------------------------------------------------

Figure 49. Iterative investigation cam-lock concept (Bowie, 2009).

78

Iterative Investigation

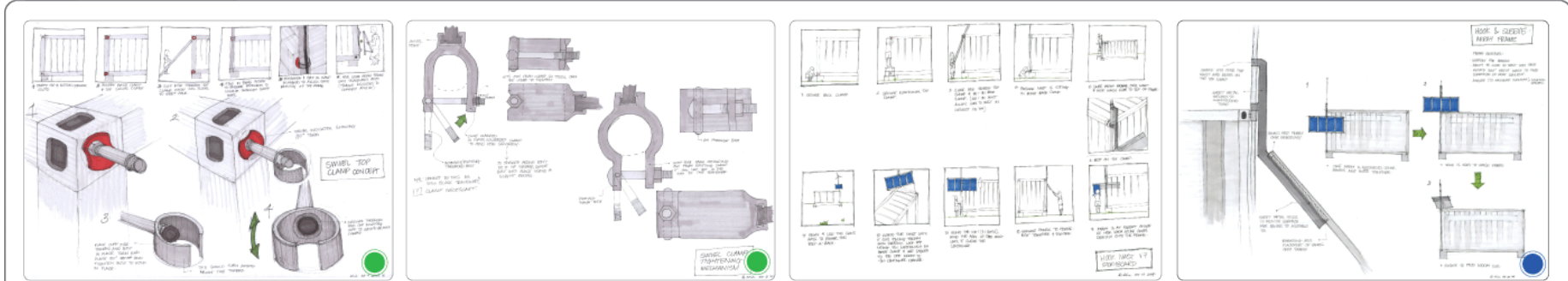

Dog-leg Concept Aim: To investigate the use of a 'dog-legged' array frame, which eliminates the need for the frame to pass through the top base connection.

Discussion: 1 Concept investigated the use of a sliding frame made from folded sheet aluminium and did not require raising from ground level, thus removing the issue caused by passing the frame through the solid base connection tube.
2 Mounting of the solar panels is enabled from ground level, as is raising them via an integrated winch.

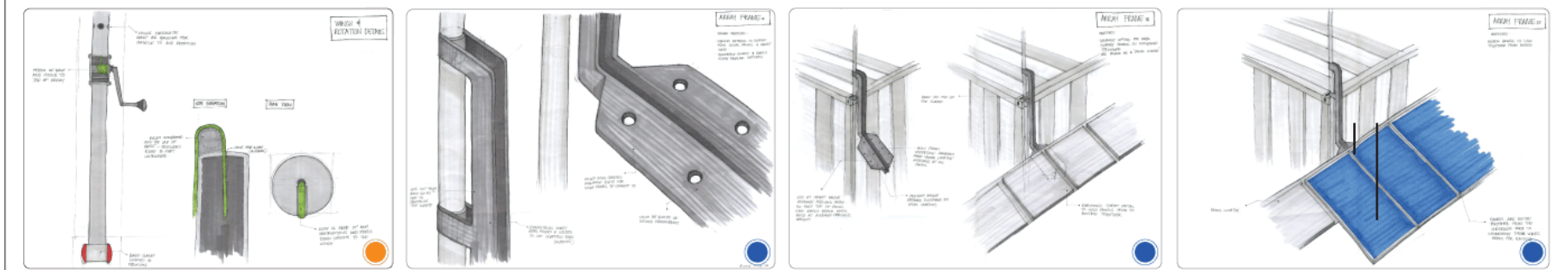

- Base Connection
- Mast
- Solar Array Frame
- + Advantage
- Disadvantage
- + Swivel mechanisms were explored for the top connection to allow for the mast to be erected with ease.
- + Clamp fasteners investigated to lock mast in place once array is correctly positioned with the sun.
- - Pulley requires attachment guide and placement of rope at top of mast
- + Folded metal sliding mechanism allows clearance of top connection.
- + Frame is pre-set at specified angle and does not require adjustment.
- - Sliding mechanism is large and requires user to slide it over the mast once the mast has been erected; cannot be done from ground level.
- - Aesthetically bulky and awkward.

Figure 50. Iterative investigation dog-leg concept (Bowie, 2009).

Iterative investigation

Iterative Investigation

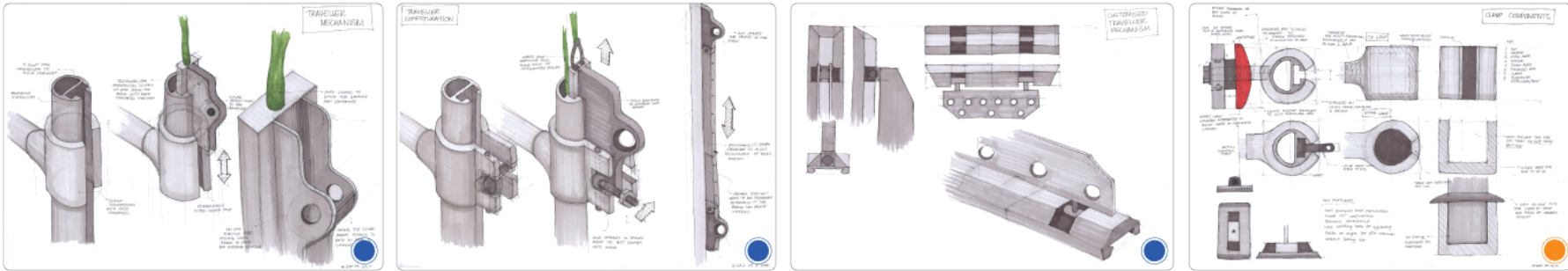

Development of Base Connection & Array Frame bracket:
To refine the system to allow for the solar array bracket to be raised without interfering the base connection.

- Discussion:**
- 1 Investigation explores concepts using OEM parts where possible.
 - 2 Product semantics high priority. Inclusion of visually indicative elements to enhance the end user experience by providing acknowledgment when parts are correctly assembled.
 - 3 Calibration of mast using a measured cuff to enable correct positioning of the solar array.

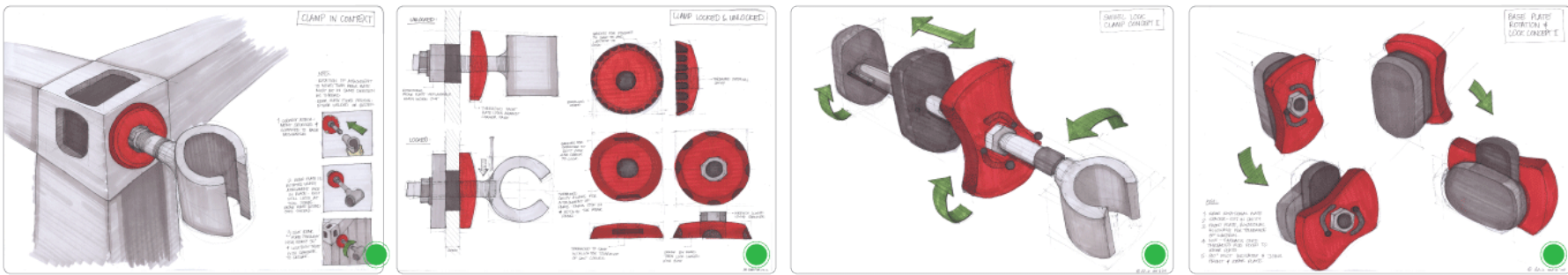

- Base Connection
- Mast
- Solar Array Frame
- + Advantage
- Disadvantage
- + Surface texture added to parts required to be secured by hand
- + Movement of shapes to clearly indicate correct positioning
- + Threaded rod utilised to allow for tolerance differences
- - Use of connection for other attachments not considered
- + Universal use of angle markings to allow for positioning of array
- + Custom aluminium extrusion inexpensive and provides better overall integration of components
- - Mast must be locked off once in position: requires integration
- + Bracket fixture allows for array frame to be dropped into place lessening impact on end user

Figure 51. Iterations of successful mechanisms (Bowie, 2009).

7.5 User testing

Aim

To refine details of the concept and its level of intuition.

Objective

Engage suitable end users (with little practical knowledge) with a realistic working prototype of the base connection to observe and discuss issues encountered.

Outcome

- User testing confirmed that the base connection was accessible to most users with limited practical knowledge.
- Ergonomically the base connection required adjustment to accommodate males.
- The product experience would be enhanced with the inclusion of the use of colour and texture
- Storyboard illustrations should be made available and work simultaneously with the assembly of the *Bach Pack*.

Discussion

Participants in the user testing were shown images of the PAB and explained the concept of the PAB Gen-2. Following this, they were set the task of mounting the base connection to the container corner and asked to narrate their thoughts and actions whilst carrying out the task.

Observation of user interaction with the base connection and subsequent discussion presented the following points:

- Participants who freely claimed to have no practical skills, asked for written or drawn instructions prior to attempting to assemble the base connection.
- Use of icons was confusing and distracted from the simplicity of the

mechanism itself. Many participants claimed preference to the use of text saying "LOCK WHEN HORIZONTAL" as it showed them the way to turn the handle and confirmed the workings of the mechanism.

- All users investigated the moving parts of the mechanism before trying to connect it to the container corner.
- The clamp handle length and distance from container were suitable sizes for females but not all males.
- Rotation of the front clamp took most users several attempts before correctly figuring out how its workings.
- Users were receptive to the aesthetic design of the base connection however all expressed positive feedback upon discussing the possible inclusion of colour coding as well as the use of texture over parts of the metal.

The following are quotes recorded from user testing participants:



"OK, I get this because I can see the whole mechanism and how it moves"

– John Sim



"It's easy to understand because everyone knows what to do when they see nuts and bolts" – Hamish Blackburn



"The weight of the mechanism makes it feel strong and reliable" – Aimee

Rollandi



"It would be more interesting to include colour or some kind of grippy texture but the overall style would suit the shipping container aesthetic" – Henry White



"Whenever I buy products that need assembling I leave it to my husband, but I found that relatively easy and quite enjoyed it" – Rosie Bowie



"Illustrations would have helped me figure out how to rotate the front clamp faster" – Julia Kelly

Base Connection & Rotational Clamp

User testing

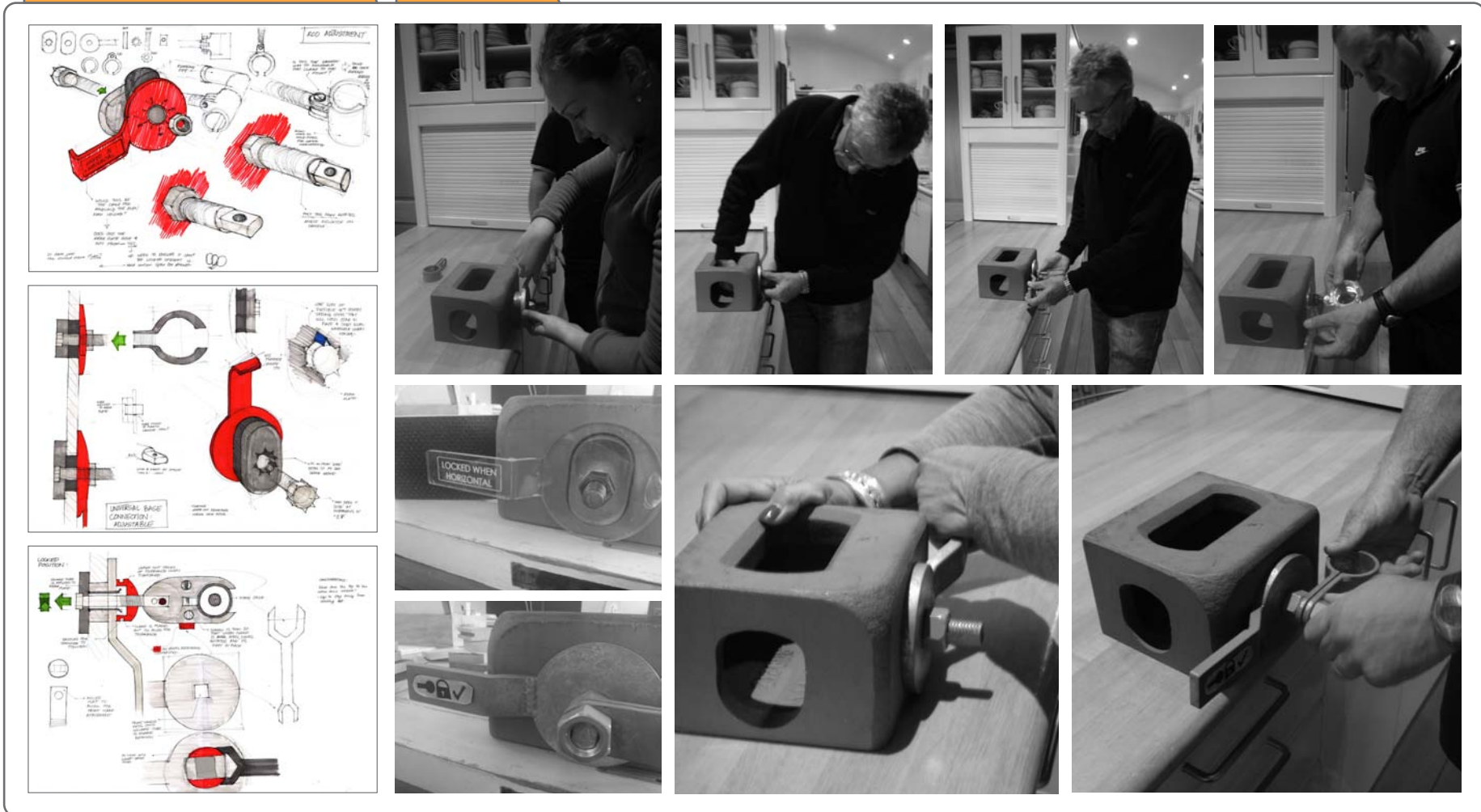

Figure 52. User testing of base connection (Bowie, 2009).

Feedback gained from users was interesting as it highlighted usability aspects that needed refining. Whilst considering user feedback when refining the base connection, it was also interesting to consider the four pleasures framework as the scope of this project, informed by an industrial design led approach, was to design to appeal to these pleasures by addressing the affective design experience involved with the assembly and deployment of the *Bach Pack*.

Table 19 provides an outline of how the four pleasures manifest themselves in the *Bach Pack* product.

<i>Pleasure</i>	<i>Concerned with:</i>	<i>Bach Pack Context</i>
Physio-pleasure	Sensory	The 'touch' points have been considered through colour coding and the use of a rubberised texture to unify the parts and enable the end user to recognise that these parts require fastening.
Socio-pleasure	Relationships	The Bach Pack can facilitate social interaction and create discussion. It is a talking point, making a statement about the end users that says, 'This is what we are about.'
Psycho-pleasure	Cognitive	The Bach Pack uses familiar methods of assembly and performance such as the way it is raised; like a flag. Icons and numbering of parts as well as illustrative diagrams assist with an intuitive assembly process resulting in a sense of satisfaction.
Ideo-pleasure	Values	The values exhibited in the Bach Pack product are based heavily around sustainability; concern for the environment and show a commitment to the future.

Table 19. *Relationship between the Bach Pack and the four pleasures* (Bowie, 2009).

CAD Iterations of PAB Gen-2

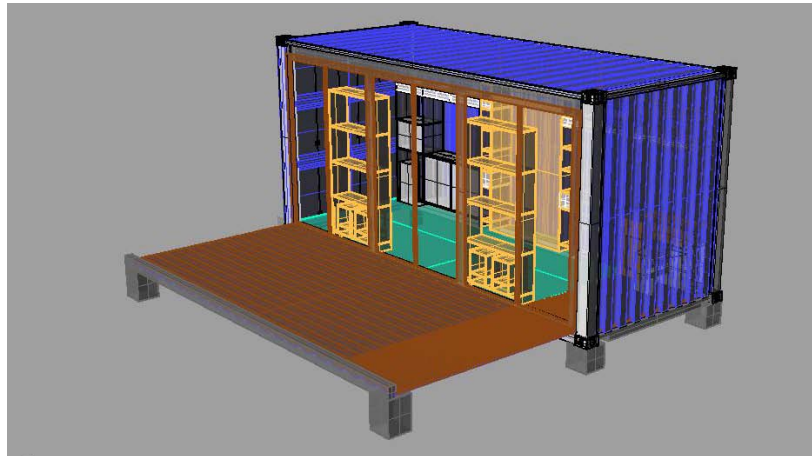
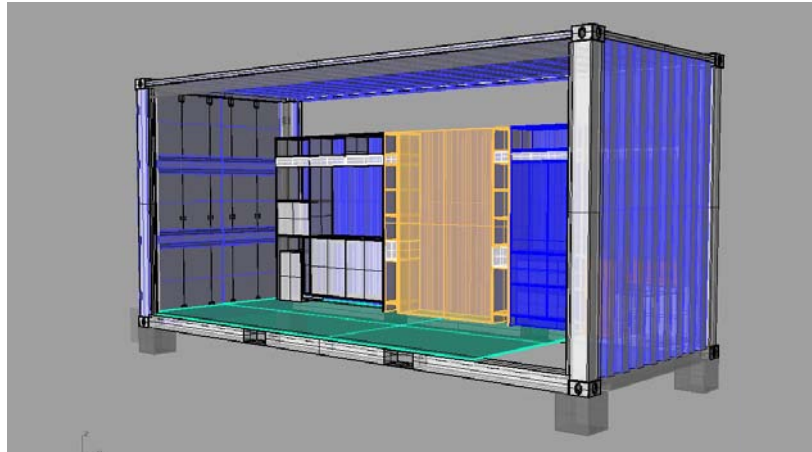

Figure 53. CAD development of base connection (Bowie, 2009).

7.6 Computer aided design modelling (CAD)

Aim

To focus on the functional aspects of the *Bach Pack* and develop the concept into a three-dimensional design suitable for evaluation.

Objective

To build on the two-dimensional drawings by considering the manufacturing processes, parts required and complete workings of the *Bach Pack* to a high level of resolution.

Outcome

The end result of CAD modelling was a finalised design of the *Bach Pack* as well as specification of OEM parts and the manufacturing of custom parts.

Discussion

CAD modelling was a hugely successful method enabling:

- Fast iterative development
- Clients to view the three-dimensional forms and their workings
- Exact dimensioning of parts
- Consideration of manufacturing processes required
- Realistic aesthetic studies

CAD Iterations of Base Connection

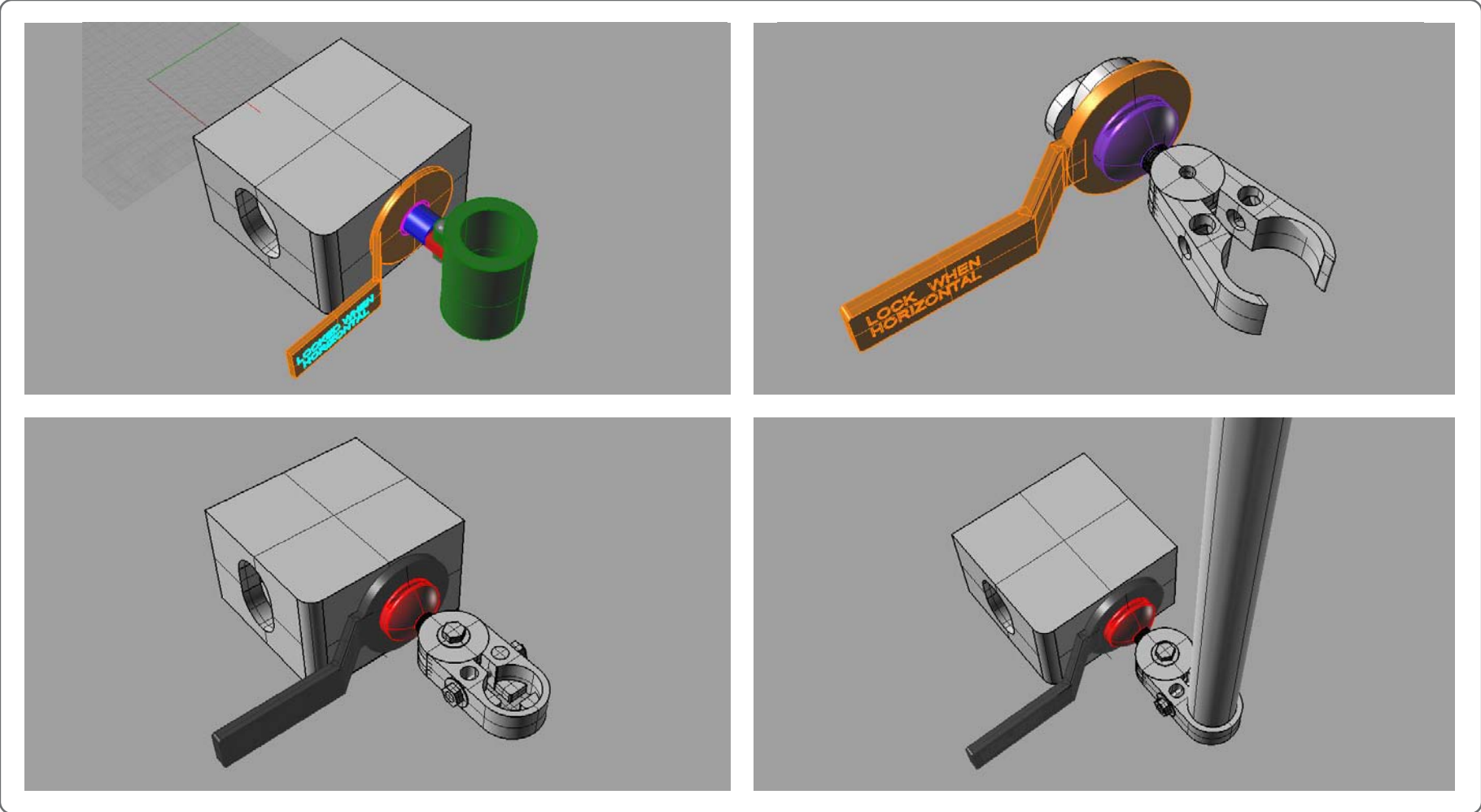

Figure 54. CAD development of base connection (Bowie, 2009).

CAD Iterations of Array Frame

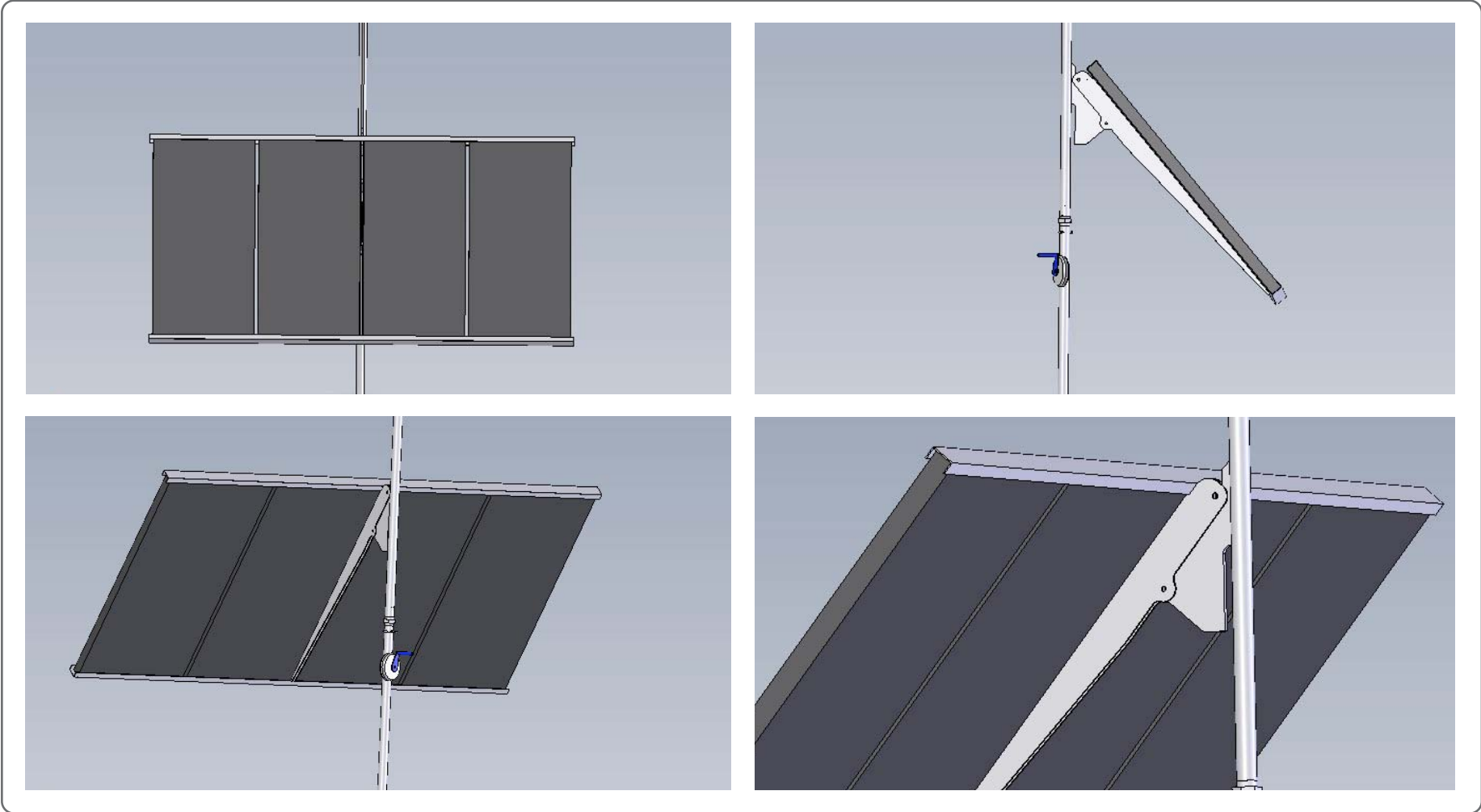

Figure 55. CAD development of array frame (Bowie, 2009).

Chapter Eight The Bach Pack: Final Design

8.0 Bach Pack: independent energy solution

The *Bach Pack* is a fully integrative accessory product designed for the *PAB Gen-2*, enabling the unit to run off-the-grid. The design features are noted in *Figures 57, 58 & 59* with reference to the performance and experience design criteria (*Chapter 6*).

Figure 56 (facing page). *Bach Pack assembled on the Port-a-Bach Generation 2* (Cassells, 2010).



Bach Pack - final design



Figure 57. *The Bach Pack final design front view* (Cassells, 2010)

Design Features

- ① Potential wind turbine mount using the same structure as the solar array.
- ② Solar array holds four solar panels.
- ③ Use of existing 'mature' technologies.
- ④ Secure mounting of panels and theft consideration.
- ⑤ Array attaches and detaches to existing shipping containers without permanent fixtures using a unified connection system.
- ⑥ Touch points requiring end-user interaction are textured and coloured to visually highlight areas that require hands-on fastening.



Figure 58. *The Bach Pack final design rear view* (Cassells, 2010)

Bach Pack - final design

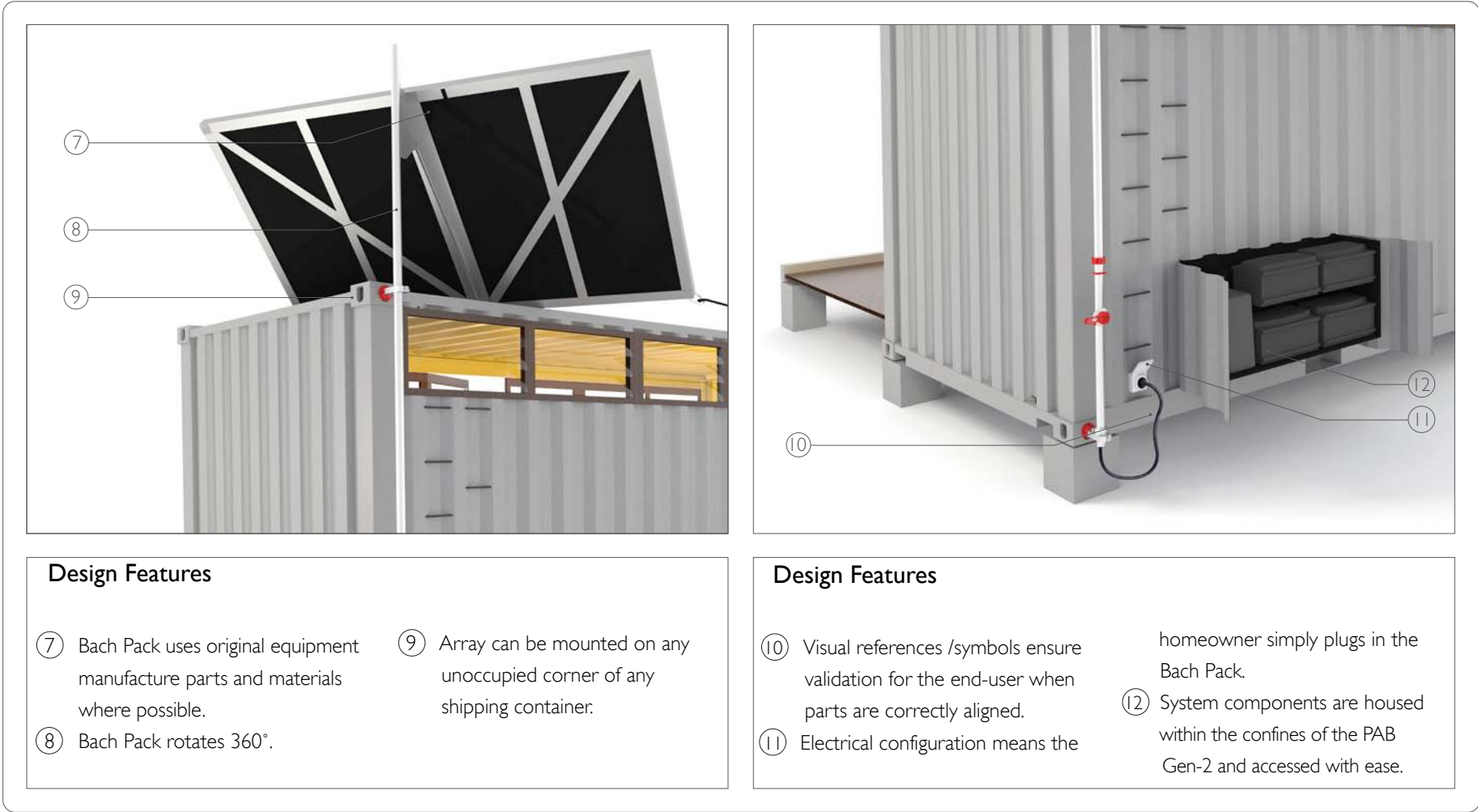
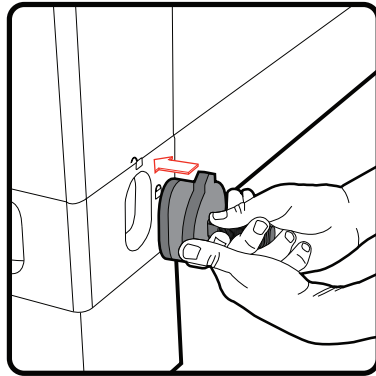
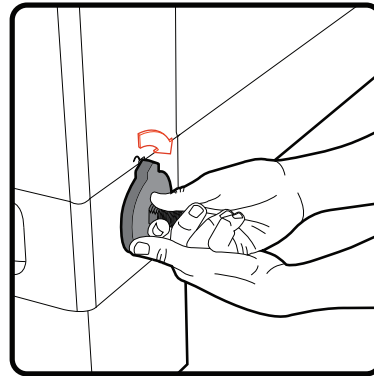

Figure 59. The Bach Pack final design rear details (Cassells, 2010).



1 Insert **base connection** to corner socket with arrow pointing to the unlocked padlock



2 Rotate the arrow clockwise until it reaches the locked padlock

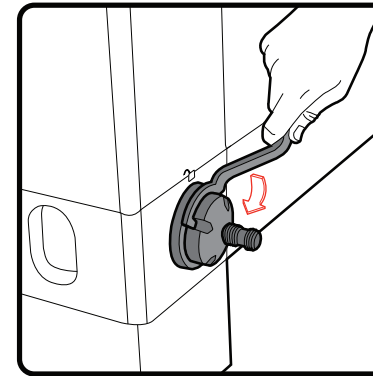

3 Screw on the **circular nut** and tighten using the **Bach Pack tool**.

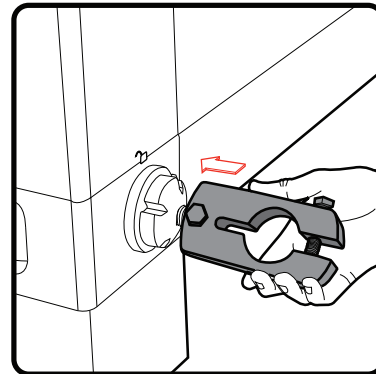

4 Screw the **mast clamp** onto the threaded rod and tighten top bolt when in place. Repeat 1-4 for corresponding corner socket.

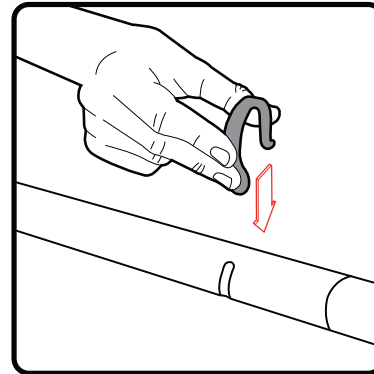

5 Assemble the two parts of the mast, and attach the **sprung steel clip**.

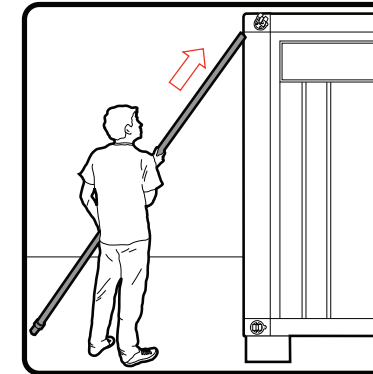

6 Raise the mast to the **top base connection** and slide through the circular hole.

Figure 60. *The Bach Pack storyboard* (Bowie, 2010).

Bach Pack - storyboard

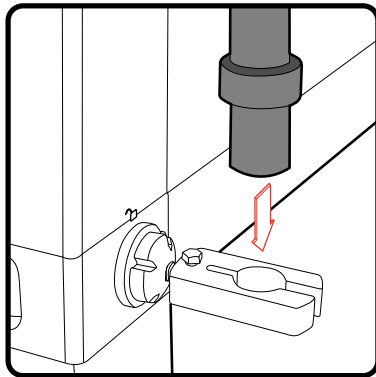

7 Lower base of mast into lowest base connection until the cuff rests flush with the top face of the mast clamp.

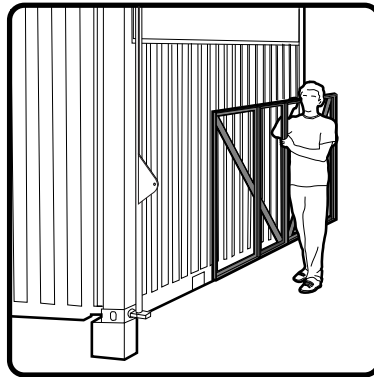

8 Retrieve the solar array frame from the under floor storage compartment of the Port-a-Bach and carry it outside.

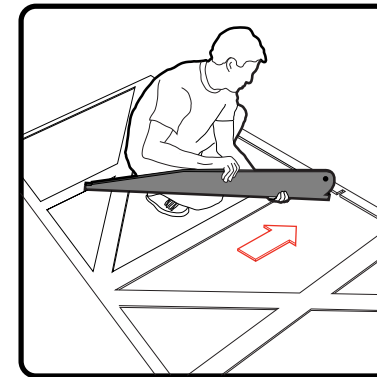

9 Mount the array frame bracket on the backside of the solar array frame. Slide left, toward the centre of the frame and use pre-drilled holes to bolt in place. Tighten using Bach Pack tool.

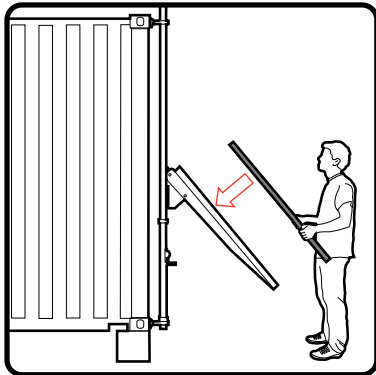

10 Hook the solar array frame onto the fixed bracket mount and bolt into place. Place solar panels into prepared beds.

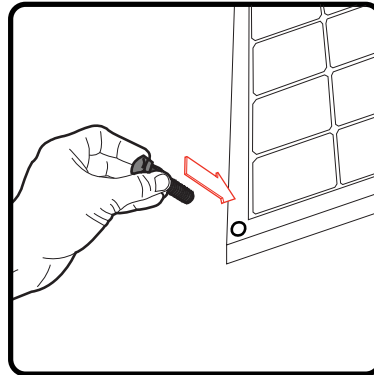

11 Locate bolts into prepared holes that run through the solar panels and the solar array frame.

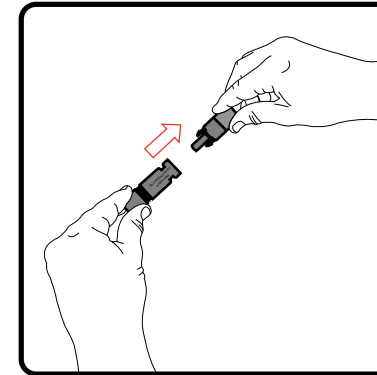

12 At rear of solar array frame, connect clips that enable the electric of the solar system.

Figure 61. *The Bach Pack storyboard* (Bowie, 2010).

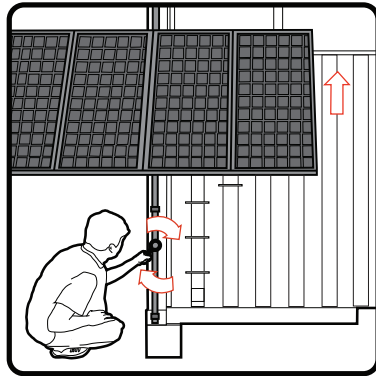

13 Wind the handle on the mast until the solar array reaches the top of the mast where a cap will no longer allow the handle to wind.

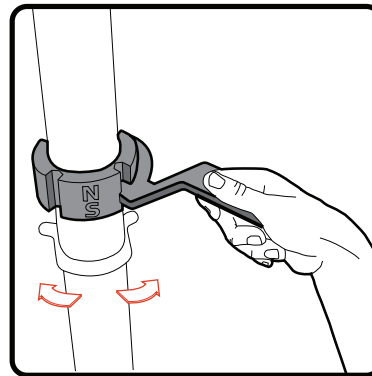

14 Using the Bach Pack tool, rotate the mast in the direction of maximum sunlight using the North/South markers to indicate the front face of the solar array.

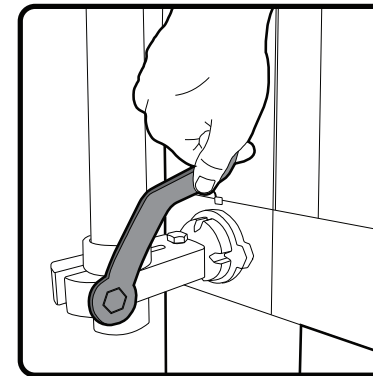

15 With the solar array in the desired orientation, the mast clamps should be locked off by tightening the bolts on the right hand side.

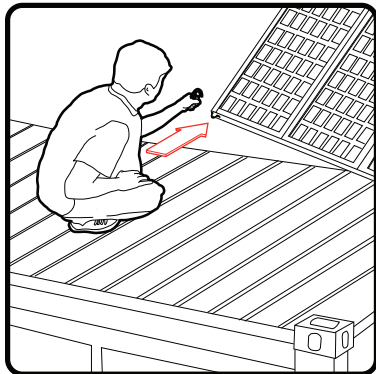

16 Assemble stays on the solar array by connecting the hooks on the rope to the nearest rooftop corners and the caribenas to the hooks mounted on the underside of the array frame. Pull tight by tensioning the rope using the camlock winch.

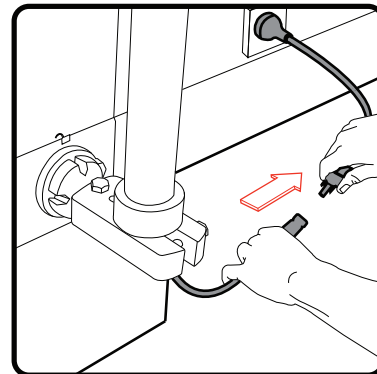

17 Connect the cord from the solar array to the main plug connected to the Port-a-Bach Generation 2.

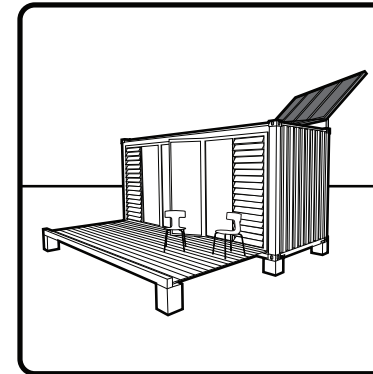

18 Sit back, relax and enjoy bach living allowing the sun to fulfill your energy needs!

Figure 62. The Bach Pack storyboard (Bowie, 2010).











8.1 Design evaluation

The completed design of the *Bach Pack* for the PAB Gen-2 was evaluated by the project team against the performance and experience criteria outlined in Chapter 6.

The evaluation results are presented in Tables 20-23.

Design Evaluation













Criteria		Required	Desirable (High)	Desirable (Moderate)	Desirable (Low)	Key: Criteria fulfilled  Criteria not fulfilled 
Solar System	Components required to enable the 3.13 AC kW hrs/week system (section 5.2) should be stored within the confines of the PAB Gen-2.				System components housed in a sealed compartment with suitable ventilation for batteries (5.2).	
	System components should be accessed with ease by the homeowner				Components are accessed from the outside of the container by opening a concealed cut-out.	
	The Bach Pack should run off a 12V system				The system is a 12V system making it more universally friendly (5.2).	
Energy Efficiency	Array must hold four solar panels				The array is designed for four solar panels to run the 3.13AC kWhrs weekly system (5.2).	
	Ability to rotate 360 degrees				The mast allows for free 360° rotation so can be orientated appropriately for each site.	
	Adjustable angle tilt of panels to maximise summer and winter sun				Panels are mounted onto a region specific, fixed angle bracket (7.4.2).	
	The performance involved in the assembly of the Bach Pack stimulates and encourages discussion surrounding self-sufficiency				Full scale testing required	
Adaptability	Array must attach and detach to existing shipping container shell without permanent fixtures				Base connection allows for complete assembly and disassembly on site (7.4.1).	
	Array can be erected on any unoccupied corner of any shipping container				Base connection uses standard container corners as the connection point (7.4.1).	
	Wind turbine can be integrated or otherwise can utilise the same components as the array				Mast has the ability for additional attachment of a small wind turbine with stays for support.	



Table 20. Design evaluation of solar array performance criteria – Part one (Bowie, 2010).











Criteria		Required	Desirable (High)	Desirable (Moderate)	Desirable (Low)	Key: Criteria fulfilled  Criteria not fulfilled 
Assembly	Electrical configuration executed during PAB Gen-2 construction requiring homeowner to simply 'plug in' the Bach Pack to the dwelling to enable the system			Once assembling the Bach Pack the end user clips together the connection from the PAB Gen-2 and the solar array to activate it.		
	Maximum of 2 individuals with a low level of practical skill and knowledge are required to set up the Bach Pack			The Bach Pack uses familiar methods of connection and assembly to allow for user friendly assembly.		
	Manual design features incorporated where possible			The solar array is raised by winding the handle, so that the end user has total control of the solar array's movement.		
Safety	Secure, safe mounting of panels and theft consideration			Panels are designed to slide into extrusions for a secure fit and can be locked to the container if end user desires.		
Manufacturing, Commercial Viability & Cost	Minimal number of parts			The Bach Pack requires a total of 19 parts to completely assemble the product.		
	Unified connection system			The base connection is used to clamp the Bach Pack mast in place and can be utilised for various other applications (7.4.1).		
	Use of existing 'mature' technologies			The Bach Pack specifies the use of existing solar panels (5.2).		
	Use of existing OEM parts and materials where possible			Existing products i.e. scaffolding tube and standard extruded aluminium have been utilised with -in the Bach Pack mast and frame.		

Table 21. Design evaluation of solar array performance criteria – Part two (Bowie, 2010).

Design Evaluation













Criteria		Required	Desirable (High)	Desirable (Moderate)	Desirable (Low)	Key: Criteria fulfilled  Criteria not fulfilled 	
Assembly	Assembly of array must induce an engaging, pleasurable and intuitive experience		 Full scale testing required				
	Product borrows principles that resemble previously 'known' activities to reference assembly & deployment of array		 Solar array is raised by winding the handle the same way clothes lines & flags are often raised (7.4.2)				
	The assembly involved in the set up of the Bach Pack should evoke leisure activity qualities		 A user friendly assembly process has been developed with the aid of illustrations and few parts.				
	Unified assembly procedure: same part can be used throughout Port-a-Bach Gen-2	The base connection designed specifically for the Bach Pack can be used throughout PAB Gen-2.					
	Touch points are coloured to visually highlight areas that require manual adjustment		 All touch points are coloured red to aid the end user when assembling the Bach Pack.				
	Touch points use texture to indicate areas that require hands-on fastening		 Rubberised texture is used on parts that require fastening i.e. base connection external nut.				
	Visual references/symbols should ensure validation for the end user when parts are correctly aligned		 The base connection explicitly tells the user when in place both by its shape and written text.				
	Risk & error management considered and incorporated into design		 All parts can only be assembled one way ensuring the product cannot be assembled otherwise.				
	Sense of reward and satisfaction both throughout assembly and upon completion		 Full scale assembly required				

Table 22. Design evaluation of solar array experience criteria – Part one (Bowie, 2010).











Criteria		Required	Desirable (High)	Desirable (Moderate)	Desirable (Low)	Key: Criteria fulfilled  Criteria not fulfilled 
Assembly	Array can be erected with minimal practical knowledge and easily comprehended			Numbering of parts and visual indication of correct placement encourage user friendly comprehension and assembly.		
	Illustrative diagrams included and used to aid a positive assembly process			Storyboard illustrations demonstrate the assembly process for the end user.		
	Bach Pack provides a sense of reliability and security once assembled			All parts are designed to be robust and secure when installed correctly.		
Context	The Bach Pack is a statement identifying homeowners as individuals whom carry an interest in and concern for self-sufficiency and sustainability			The Bach Pack accessory product is a strong visual symbol differentiating the PAB Gen-2 end users from others.		
	Bach Pack does not compromise the aesthetic integrity of the shipping container and overall dwelling as a 'bach' and place of relaxation			The Bach Pack is not overwhelming in scale or design. It sits comfortably within the shipping container aesthetic.		
	Aesthetic compliments and references the robust, reliable shipping container aesthetic.			Solid, visual elements were used to form the solar array and to reference the strength provided by the shipping container.		
	Array induces a dignified sense of gratification as an additional module to PAB Gen-2			Requires feedback from PAB Gen-2 homeowners		
Safety	Product in no way endangers the user if installed correctly and instructions followed		Full scale testing required			

Table 23. Design evaluation of solar array experience criteria – Part two (Bowie, 2010).

The design evaluation criteria summary (Figure 60) revealed the following:

- 29/35 criteria were fulfilled
- 1/35 criteria was not fulfilled
- 5/35 criteria require further testing and feedback

The criteria that was not fulfilled was the adjustable angle tilt of panels to maximise summer and winter sun. Whilst designing the array frame, the importance of eliminating moving parts become imperative to the simplicity of the overall design. In order to maximise sunlight, users would be required to adjust the solar panels each season without gaining substantial benefits. As a result, the *Bach Pack* includes a fixed, latitude specific solar array mount, set to the optimum angle for winter; as this will be when the most energy is required.

Several criteria were deemed unsuitable for evaluating without further investigation. These criteria rely on the testing and subsequent feedback from end users engaging with the full scale solar mast.

The evaluation process used for this research relied on valuable research and subsequent compilation of suitable criteria in order to assess the final product. The performance criteria was more direct and therefore easier to assess, whereas the experience criteria was more subjective and therefore more of a challenge. The project team endeavoured to remain as objective as possible when evaluating the experience criteria.

Criteria Category	Fulfilled	Not Fulfilled	Requires further work
Performance:			
Requirement	5	0	0
Desirable (High)	10	0	0
Desirable (Moderate)	1	0	1
Desirable (Low)	0	1	0
Experience:			
Requirement	0	0	1
Desirable (High)	12	0	3
Desirable (Moderate)	N/A	N/A	N/A
Desirable (Low)	N/A	N/A	N/A

Figure 60. Summary of design criteria evaluation for the *Bach Pack* (Bowie, 2009).

8.2 Provisional Patent

The development of a base connection enabling both secure clamping and sub-attachment to shipping container corners is an innovative concept. As such a provisional patent has been submitted with the Intellectual Property Office of New Zealand as of January 22, 2010.

Invention title: Shipping container base clamp connection product

Patent number: 582816

8.3 Conclusion

The aim of this research was to develop an integrative energy system that enables the *PAB Gen-2* to be off-the-grid. A research approach was formulated to inform the development of product specifications required along with developing a deeper understanding of the end user requirements.

Criteria were developed and used to inform the iterative development of the product and its components. The design evolved initially through two-dimensional renderings and was developed through a range of prototyping activities both physical ('works' like) models and analytical (CAD) models informed by reviews and assessments.

Significant outcomes included:

- 1 Calculating the 3.13 AC kW hrs/week energy system.
- 2 Specification of the appliances and subsequently the independent energy system components.
- 3 Selection of the 'Raise the Array' concept and following this, the design specification of a base connection, mast and solar array frame.
- 4 The development of the base connection to the corner of the shipping container allowing sub-attachment of the mast.
- 5 The decision to use a wormdrive mechanism to raise and lower the array.
- 6 The submission of a provisional patent for the base connection design.

A constant flow of communication between the researcher and the clients enabled a successful product outcome for this stage of the development of the *Bach Pack* product. The evaluation phase recognised that the *Bach Pack* fulfilled the majority of criteria.

8.4 Further research

As noted in the summary of design criteria evaluation (*Section 8.1*), there are areas that would benefit from further development in order to further develop the intimate aspects regarding user experience.

Other areas of the *Bach Pack* that would benefit from further development include:

- Observation of end user testing of a full-scale, working prototype of the solar array frame and mast focussing on the assembly experience.
- External evaluation from possible end users. i.e. a focus group.
- Examination from an engineer for structural confirmation.
- Development and integration of a wind turbine module that connects to the existing *Bach Pack* mast.
- The development, production and marketing of the shipping container base connection product (currently covered by a provisional patent).

As mentioned in *Section 1.1*, a series of product development initiatives were identified. The following are yet to be explored:

- Modular furniture providing a more customisable product.
- Modular features to enable multiple PAB units to work collectively.
- Modular accessories allowing the PAB to move comfortably from sub-tropical to alpine temperature.

Chapter Nine Reference List, Figures & Table Index

9.0 Reference List

- Allen, E. (2005). *How buildings work : the natural order of architecture* (3rd ed.). Oxford ; New York: Oxford University Press.
- AM Solar (2009). *Mounts & Tilt Bars*. Retrieved July 10 2009, from <http://www.amsolar.com/mountsandtiltbars.html>
- Architecture for Humanity. (2006). *Design Like You Give a Damn: Architectural Responses to Humanitarian Crises*. New York: Metropolis Books.
- Bell, P. (2009). *Kiwi Prefab: Prefabricated Housing in New Zealand*. Unpublished thesis, Victoria University, Wellington.
- Bennett, A. D., Reynolds, G. A. (2009). *Shedding new light on solar-array design: extruded aluminium framing improves collector efficiency, economics*. *Machine Design* (81), 66-69.
- Berkebile, R.J., McLennan, J.F. (1999). *At the Edge: The Living Building*. *World and I*, 14, 10. p.160. Retrieved October 14, 2009
- Black, D. S. (2008). *Living Off the Grid: A Simple Guide to Creating and Maintaining a Self-Reliant Supply of Energy, Water, Shelter and More*. New York: Sky Horse Publishing.
- Blair, A. (2009 Apr-Jun). *More on Battery Lifespans*. *ReNew: Technology for a Sustainable Future*, 96.
- Borrego Solar. (2008). *Glossary*. Retrieved January 20, 2010, from <http://www.borregosolar.com/resources/glossary.php>
- Braungart, M. M., W. (2008). *Cradle to Cradle; Remaking the way we make things* (2nd ed.). London: Vintage Books.
- Briody Lipp, K., Dewinkle, C., Gates, R., Hanson, M., Kabala, S., Steinhart, J., Thorn-sjo, M. (1979). *Pathway to Energy Sufficiency: The 2050 Study* (Vol. 3). San Francisco: Friends of the Earth.
- Brooke, M. Z., & Mills, W. R. (2003). *New product development : successful innovation in the marketplace*. New York: International Business Press.
- Carson, R. (1963). *Silent Spring*. London: Trinity Press.
- Cassim, J., Clarkson, J., Coleman, R., Dong, H. (2007). *Design for Inclusivity: A Practical Guide to Accessible Innovative and User-Centered Design*. Burlington. Burlington: Gower Publishing Limited.
- Centre for Disease Control and Prevention, (2009). *Healthy Places Terminology*. Retrieved January 8, 2009, from <http://www.cdc.gov/healthyplaces/terminology.htm>
- Chhibber, S., Porter, M., Porter, S. (2008). *What Makes You Tick - An Investigation of the Pleasure Needs of Different Population Segments*. In P. Desmet, van Erp, J., Karlsson, M. (Ed.), *Design & Emotion Moves* (pp. 324-361). Newcastle: Cambridge Scholars Publishing.
- Cofaigh, E. O., Olley, J. A., Lewis, O. (1996). *The Climatic Dwelling: An introduction to climate-responsive residential architecture*. London: James & James.
- Cunningham, A. (2007). *Reaching for Rays: Scientists Work Towards a Solar-Based Energy System*. *Science News*, 171 (21), 2. 328-329.

- Datschefski, E. (2001). *The Total Beauty of Sustainable Products*. London: RotoVision SA.
- Davies, C. (2005). *The Prefabricated Home*. London: Reaktion Books
- DeMaria, P. (2009). *Peter DeMaria on the Future of Prefab*. Dwell. Retrieved November 6, 2009 from <http://www.dwell.com/articles/peter-demaria-on-the-future-of-prefab.html>
- Desmet, P.M.A, & Hekkert., P. (2007). *Framework of Product Experience*. Retrieved August 19 2009, from <http://www.ijdesign.org/ojs/index.php/IJDesign/article/view/66/15>
- Desmet, P.M.A. (2003). *A Multilayered Model of Product Emotions*. (Paper). *The Design Journal*, 13.
- Desmet, P.M.A., van Erp, J., & Karlsson. M. (2008). *Design and Emotion Moves*. Newcastle: Cambridge Scholars Publishing.
- Downton, P. (2003). *Design Research*. Melbourne: RMIT University Press.
- Epstein, R. (1993). *Living off the grid: 1994 guide to solar power for home owners*. Mother Earth News (141).
- Fiell, C. P. (2006). *Industrial Design A-Z* (2 ed.). Tokyo: Taschen.
- Fuad-Luke, A. (2004). *The Eco-Design Handbook* (2 ed.). London: Thames & Hudson Ltd.
- Gabler, B. (2006). *weeHouse*. Retrieved April 18, 2009, from http://weehouse.com/flash/SFWA_index.html#/sitebuilt/
- Gerlat, A. (2006). *What's driving alternative energy?* Waste News, 8. Retrieved August 3, 2009 from General OneFile database.
- Godsell, S. (2005). *Future Shack*. Retrieved June 17, 2009, from <http://www.seangodsell.com/>
- Harker, E. (2009). *The Commoditization of Architecture*. Retrieved November 22, 2009, from www.ericharker.com/work/the-commoditization-of-architecture.pdf
- Hesel, S. (2001). *Future Shack*. Australia Architecture. Retrieved May 3, 2009, from <http://www.architectureaustralia.com.au/aa/aaissue.php?article=11&issueid=200109&typeon=2>
- Huesch, L. (2009, Apr-Jun). *Simple Solar Panel Mounting*. *ReNew: Technology for a Sustainable Future*, 96.
- Jordan, P. (2000). *Designing Pleasurable Products - An introduction to the new human factors*. Retrieved August 18, 2009, from Google database. Available from http://books.google.com/books?id=qNMfx8SVTPEC&pg=PA4&lpg=PA4&dq=jordans+hierarchy+of+consumer+needs&source=bl&ots=gG5_E9S0is&sig=2KLiglrO20imvZrvM_tROZv6NVI&hl=en&ei=IWmKStWIIYzusQOjx9XPDQ&sa=X&oi=book_result&ct=result&resnum=5#v=onepage&q=&f=false
- Kelly, M. (1995). *Living off the grid: to the Kelly family, self-reliant conservation means living free of power companies, poles, nuclear plants and monthly electric bills*. *Country Journal*, (22), 45-48.
- Kelm, B., Scoates, C., Urbach, H., Kronenburg, R., Betsky, A. (2003). *Lot-Ek: Mobile Dwelling Unit*. New York: Distributed Art Publishers.

Kermeliotis, T. (2009). Unplugging from the world's power lines. Retrieved January 13, 2010, from <http://www.cnn.com/2009/WORLD/europe/12/16/off.grid.living/index.html>

Kisslinger, J. (2004). Planet for Life. Retrieved October 15, 2009, from <http://planetforlife.com/oilcrisis/index.html>

Kotnik, J. (2008). Container Architecture: This Book Contains 6441 Containers. Barcelona: Links International.

Kronenburg, R. (2008). Portable architecture : design and technology (Rev. ed.). Basel; Boston: Birkhäuser.

Levinson, M. (2006). The Box: How the Shipping Container Made the World Smaller and the World Economy Bigger. New York: Princeton University Press.

Makower, J., Pernick, R., Wilder, C. (2009). Clean Energy Trends: The Clean Tech Market Authority. Retrieved September 24, 2009, from <http://www.cleantech.com/reports/pdf/Trends2009.pdf>

McCarthy, C. (1998). A Summer Place: postcolonial retellings of the New Zealand bach. Retrieved November 4, 2009, from University of Otago: <http://english.chass.ncsu.edu/jouvert/v2i2/MCCART.HTM>

McDermott, C. (1997). Twentieth Century Design. London: Carlton Books Limited.

McDonough, W., & Braungart, M. (2008). Cradle to Cradle; Remaking the way we make things (2nd ed.). London: Vintage Books.

MOED (2009). New Zealand Energy Greenhouse Gas Emissions 2009 released. Retrieved August 18, 2009, from http://www.med.govt.nz/templates/MultipageDocumentTOC____41215.aspx

Mollerup, P. (2001). Collapsibles; A Design Album of Space-Saving Objects (1 ed.). London: Thames & Hudson.

Motavalli, J. (2005 Jul-Aug). Unplugging: living off the grid. E, 44-45.

Mulrooney, P. (2008). Prefabs: quicker, cheaper, better. The Dominion Post, p. B5. Retrieved November 5, 2008.

New Net. (2009). US Renewable energy experiences double digit growth as traditional fossil fuels decline. Retrieved August 18, 2009, from <http://www.newenergy-worldnetwork.com/alternative-energy-knowledge-bank/us-renewable-energy-experiences-double-digit-growth-as-traditional-fossil-fuels-decline-according-to-report.html>

OCETA. (1999). ECO-Nomad - Combined Mechanical Utility Container. Retrieved June 18, 2009 from <http://www.economad.com/>

Open University. (2004). The Four Pleasures. Retrieved December 22, 2009, from <http://openlearn.open.ac.uk/mod/resource/view.php?id159825>

Pawley, M. (1990). Buckminster Fuller. London: Trefoil Publications.

Phillips, J. (2009). Beach Culture - The Kiwi Dream. Retrieved November 4, 2009,

from Encyclopedia of New Zealand: <http://www.teara.govt.nz/en/beach-culture/5>

Rankin, A. (2006). Midsummer. Retrieved June 18, 2009, from <http://midsummerenergy.co.uk/solar-panel-information/Guides/Yachts>

Rosen, N. (2007). How To Live Off-Grid: Journeys Outside the System. London: Transworld Publishers.

Ryker, L. (2007). OffThe Grid Homes: Case Studies for Sustainable Living. Layton: Gibbs Smith.

Scanlon, M. (1994). Living off the grid, part II: Northern Exposure. Mother Earth News, (142), 48-55.

Siegal, J. (2008). More mobile : portable architecture for today. New York: Princeton Architectural Press.

Slavid, R. (2007). Micro Very Small Buildings. London: Laurence King Publishing Ltd.

Smith, J. D. (2006). Shipping Containers as Building Components. University of Brighton: Brighton. Retrieved October 22, 2009 from www.cityzen.biz/containerresearch.pdf

Sylvester, M. (2003). Fab Prefab. Retrieved October 28, 2009, from <http://www.fabprefab.com/fabfiles/containerbayhome.htm>

The Off Grid Home. (2009). What's Off Grid? Retrieved October 28, 2009 from <http://www.blogcatalog.com/blog/the-off-grid-home>

Thornton, J. (2007). The Simple Life. New Zealand Home and Entertaining, 92-93.

Turner, L. (2009, Jan-Mar). Better Batteries - Where Are They? ReNew: Technology for a Sustainable Future, 104.

Ulrich, K.T., Eppinger, S. D. (2000). Product Design and Development (Second ed.). New York: The McGraw-Hill Companies, Inc.

U.S. Department of Energy (2007). Clean Air, Soil and Water. Retrieved October 29, 2009 from <http://www.energy.gov/environment/cleanairesoil.htm>

U.S. Department of Energy (2009). Climate Change. Retrieved October 29, 2009 from <http://www.energy.gov/sciencetech/climatechange.htm>

U.S. Department of Energy (2009). Electric Power. Retrieved October 29, 2009 from <http://www.energy.gov/energysources/electricpower.htm>

U.S. Department of Energy (2009). Fossil Fuels. Retrieved October 29, 2009 from <http://www.energy.gov/energysources/fossilfuels.htm>

U.S. Department of Energy (2009). President Obama Announces \$3.4 billion Investment to Spur transition to Smart Energy Grid. Retrieved October 29, 2009 from <http://www.energy.gov/news2009/8216.htm>

9.1 Figure Index

NB: All figures referenced to author and excluded from the figure index are original belonging to the researcher.

Figure 1: *Port-a-Bach exterior*.....2

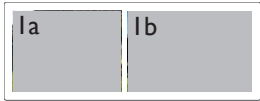

1a: McCreddie, P. (2006). *Port-a-Bach closed*. Original photograph.

1b: McCreddie, P. (2006). *Port-a-Bach exterior*. Original photograph.

Figure 3: *Port-a-Bach interior*.....3



3a: McCreddie, P. (2006). *Port-a-Bach interior*. Original photograph.

3b: McCreddie, P. (2006). *Port-a-Bach interior with bed*. Original photograph.

Figure 12: *Early examples of kiwi baches*.....17

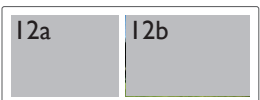

12a: Austin, S. (2007). *Kiwi Bach, Mangawai, Northland, North Island, New Zealand*. Retrieved January 12, 2010 from <http://www.flickr.com/photos/sondyaustin/1352911308/>

12b: Grinsted, T. (2009). *White's bach*. Original photograph.

Figure 13: *Vintage portable architecture vs contemporary portable, prefabricated architecture*.....19



13a: Winnebago Parts. (2000). *1967 Lifetime, trailers, motorhomes*. Retrieved May 11, 2009 from <http://www.winnebago.com/justforfun.php>

13b: Prefab Cosm. (2008). *The m-ch (micro-compact home)*. Retrieved January 10, 2010 from <http://prefabcosm.com/blog/2008/01/10/m-ch-micro-compacthome/>

Figure 14: *Micro-compact home*.....20



14a: Micro Compact Home. (2005). *Micro Compact Home*. Retrieved January 12, 2010 from http://www.microcompacthome.com/pics/start_1.jpg

14b: Micro Compact Home. (2005). *Low E-Home*. Retrieved January 12, 2010 from <http://www.microcompacthome.com/projects/index.php?kat=projects&con=low&picc=2>

Figure 15: *Redundant shipping containers*.....22

Hasan, Dian. (2009). *The Ubiquitous Shipping Container Takes On a New Role*. Retrieved January 10, 2010 from <http://dianhasan.wordpress.com/2009/05/22/the-ubiquitous-shipping-container-takes-on-a-new-role/>

Figure 16: *Container House*.....23



- 16a: Alsbach-Stevens, P. (2007) as referenced by TreeHugger (2008). *The container house exterior*. Retrieved January 12, 2010 from <http://www.treehugger.com/files/2008/04/shipping-container-house-ross-stevens.php>
- 16b: Alsbach-Stevens, P. (2007) as referenced by TreeHugger (2008). *The container house interior*. Retrieved January 12, 2010 from <http://www.treehugger.com/files/2008/04/shipping-container-house-ross-stevens.php>

Figure 17: *Annual energy outlook 2010*.....25

Newell, R. (2009). *Annual Energy Outlook 2010 Early Release Summary Presentation*. Retrieved December 23, 2009 from <http://www.eia.doe.gov/oiia/aeo/index.html>]

Figure 18: *Eco-Nomad*.....26



- 18a: OCETA Eco-Nomad. (1999). *Eco-Nomad combined utility container*. Retrieved January 12, 2010 from http://www.oceta.on.ca/profiles/economad/economad_tech.html
- 18b: OCETA Eco-Nomad. (1999). *Eco-Nomad control systems interface*. Retrieved January 12, 2010 from http://www.oceta.on.ca/profiles/economad/economad_tech.html

Figure 19: *Contemporary biomimicry*.....26

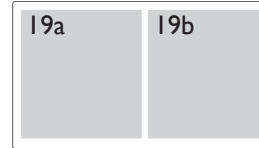

- 19a: Wikimedia. (2009). *Gliesdorf Solarbaum*. Retrieved December 13, 2009 from <http://commons.wikimedia.org/wiki/File:Gliesdorf.Solarbaum.jpg>
- 19b: Mbeleko. (2009). *Solar energy tree*. Retrieved January 12, 2010 from <http://www.mbeleko.co.uk/images/solar-energy-tree-milan.png>

Figure 20: *Emergency Response Studio*.....30



- 20a: Villinski, P. (2008). *Emergency Response Studio exterior*. Retrieved March 12, 2009 from <http://www.emergencyresponsestudio.org/images.html>
- 20b: Villinski, P. (2008). *Emergency Response Studio interior*. Retrieved March 12, 2009 from <http://www.emergencyresponsestudio.org/images.html>

Figure 21: *Living off-the-grid on a yacht*.....32



- 21a: Bavaria charter. (n.d.). *Bavaria cruiser*. Retrieved January 12, 2010 from http://www.bavaria-charter.com/yacht-charter-prices-majorca-7.1__en-bavaria~34cr-139_0.html
- 21b: The Moorings. (2009). *Moorings 54.5*. Retrieved January 12, 2010 from <http://www.moorings.com/charter-fleet/moorings-545>

Figure 22: User interaction against on and off-the-grid dwellings.....35

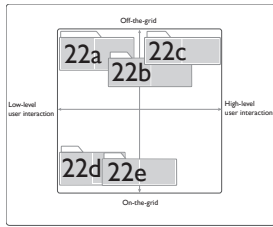

- 22a: *Eco-Nomad*: reference Figure 18
- 22b: *Emergency Response Studio*: reference Figure 20
- 22c: *Yacht*: Reference figure 21
- 22d: *Micro-Compact Home*: reference Figure 14
- 22e: *Port-a-Bach*: reference Figures 1b & 3a

Figure 23: End user experience against type of design used in off-the-grid dwellings.....35

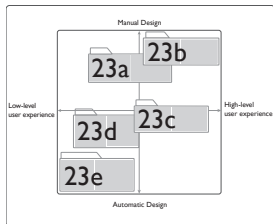

- 23a: *Emergency Response Studio*: reference Figure 20
- 23b: *Yacht*: reference Figure 21
- 23c: *Port-a-Bach*: reference Figures 1b & 3a
- 23d: *Micro-Compact Home*: reference Figure 14
- 23e: *Eco-Nomad*: reference Figure 18

Figure 24: Solar panels integrated into residential properties.....36



- 24a: CalFinder. (2009). *State home solar panels*. Retrieved December 24, 2009 from <http://solar.calfinder.com/blog/wp-content/uploads/2009/10/state-home-solar-panels.jpg>
- 24b: Go Green Together. (2008). *Solar house*. Retrieved December 24, 2009 from <http://www.gogreentogogether.ca/files/SolarHouse.jpg>

Figure 25: Stand alone solar array frames.....36



- 25a: Wilder, J. (2004). *Solar panel array*. Retrieved December 24, 2009 from <http://www.power-talk.net/images/solar-panel-array-2.jpg>
- 25b: GladeWinds. (2007). *Solar array garden mount*. Retrieved December 24, 2009 from <http://gladewinds.com/wp-content/uploads/2009/07/solar-array-garden-mount.jpg>

Figure 26: Solar array level of design against cost.....38

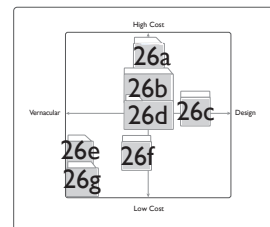

- 26a: Bowie, C. (2009). *Eco Innovation solar array*. Original photograph.

- 26b: Advance Solar. (2007). *Container array*. Retrieved November 11, 2009 from <http://www.advancesolar.ca/products.php?cat=systems>
- 26c: Really Natural. (2008). *Solar Stik portable solar array*. Retrieved November 11, 2009 from http://www.reallynatural.com/archives/alternative-energy/solar_stik_portable_solar_arra.php
- 26d: Villinski, P. (2008). *Emergency Response Studio exterior*. Retrieved June 19, 2009 from <http://www.emergencyresponsestudio.org/images.html>
- 26e: Bowie, C. (2009). *Metal solar array*. Original photograph.
- 26f: Bowie, C. (2009). *Carterton solar array*. Original photograph.
- 26g: Altenergy. (2005). *Home built solar mount*. Retrieved December 26, 2009 from <http://altenergy.blog-city.com/mount.htm>

Figure 27: Solar array frames: materials and method of attachment.....39



- 27a: Building with awareness. (2008). *Mounting pv panels to pitched metal roof*. Retrieved December 24, 2009 from <http://www.synchronos.com/blog/wp-content/uploads/2008/12/mounting-pv-panels-to-pitched-metal-roof.jpg>
- 27b: How Stuff Works. (2009). *Greening my home*. Retrieved December 24, 2009 from <http://home.howstuffworks.com/home-improvement/energy-efficiency/greening-home-increase-property-value.htm>
- 27c: *Home built solar mount: reference Figure 26g*.
- 27d: Altenergy. (2005). *Concrete foundation*. Retrieved December 26, 2009 from <http://altenergy.blog-city.com/mount.htm>

Figure 29: Off-the-grid system diagram.....48

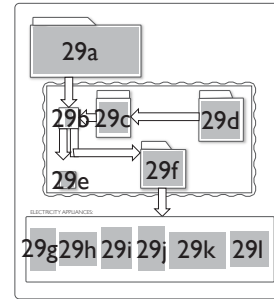

- 29a: Mitsubishi. (n.d.). *Mitsubishi electric PV MF100EC4*. Retrieved November 11, 2009 from <http://www.bdt.co.nz/solar/product.asp?item=754101>
- 29b: Eco Innovation. (2007). *FlexMax 60 solar controller*. Retrieved April 26, 2009 from <http://www.ecoinnovation.co.nz/p-271-flex-max-60-solar-controller.aspx>
- 29c: Eco Innovation. (2007). *Transformer/rectifier*. Retrieved April 26, 2009 from <http://www.ecoinnovation.co.nz/p-241-12kw-transformerrectifier-pack-for-1224-vdc.aspx>
- 29d: Happy productions. (2004). *Honda 2000 watt generator*. Retrieved December 26, 2009 from <http://www.happyproductions.com/images/equipment/slides/Honda%202000%20watt%20Generator.html>
- 29e: Eco Innovation. (2007). *Efergy meter*. Retrieved December 24, 2009 from <http://www.ecoinnovation.co.nz/p-465-efergy-meter.aspx>
- 29f: Lynkos. (2002). *Exide battery*. Retrieved April 18, 2009 from <http://www.lynkos.cz/content.php?l=en&index=2113#top>
- 29g: Ultrashock. (2003). *Lightbulb*. Retrieved December 26, 2009 from <http://www.ultrashock.com/forums/photoshop-battles/lightbulb-weekly-05-09-a124338.html>
- 29h: Serada. (2009). *C50l Refrigerator*. Retrieved March 26, 2009 from <http://www.serada.co.nz/>
- 29i: Chicargoland Television. (2009). *Cellphone*. Retrieved December 26, 2009 from <http://weblogs.ctv.com/features/health/livinghealthy/2009/09/can-cell->

phones-cause-cancer.html

- 29j: Eco John. (2009). *Eco John Basic-1 2*. Retrieved March 27, 2009 from <http://ecojohn.com/catalog/basic-series-brochure.pdf>
- 29k: Apple. (2009). *Macbook Pro*. Retrieved December 26, 2009 from <http://www.apple.com/macbookpro/>
- 29l: Gadget Speak. (2007). *Logitech portable speakers*. Retrieved December 26, 2009 from http://www.gadgetspeak.com/gadget/article.rhtm/755/43785-2/Logitech_Speaker_system_for_the_Apple_iPhtml

Figure 39: *Container corner castings*.....67

Pacific Marine & Industrial. (n.d). *Container corner castings*. Retrieved January 10, 2009 from <http://www.pacificmarine.net/containerparts.htm>

Figure 41: *Fastener analysis*.....68

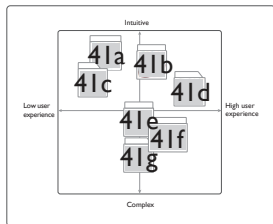

- 41a: Trade India. (2009). *Scaffolding clamps*. Retrieved December 24, 2009 from <http://www.tradeindia.com/selloffer/1694359/Scaffolding-Clamps.html>
- 41b: SailNet. (2009). *Harken - Aluminum Micro Cam Cleat*. Retrieved December 24, 2009 from http://shop.sailnet.com/product_info.php/products_id/23950
- 41c: Ebay. (2009). *Wide Body M8 Rivet Nut Rivnut Nutsert*. Retrieved December 24, 2009 from http://cgi.ebay.co.uk/WIDE-BODY-M8-Rivet-Nut-Rivnut-Nutsert-Pack-of-10_W0QQitemZ160393499821QQcategoryZ26261QQcmdZViewItemQQ_trksidZp4340.m263QQ_trkparmsZalgo%3DSIC%26its%3DI%26itu%3DUCI%252BIA%252BUA%252BIEW%252BFICS%252BUI%26otn%3DI%26ps%3D63#ht_532wt_683

2BUFI%26otn%3DI%26ps%3D63#ht_532wt_683

- 41d: Southco. (2006). *Dzus Lion Quarter-Turn Fasteners*. Retrieved December 24, 2009 from <http://www.southco.com/resources/operation/flashviewer.aspx?file=82.swf>
- 41e: Toggler. (2009). *Snap Toggle*. Retrieved December 24, 2009 from <http://www.toggler.com/snaptogglevideoHome.swf>
- 41f: Beyond Bikes. (2009). *Quick release seat clamp*. Retrieved December 24, 2009 from http://www.beyondbikes.com.au/index.php?main_page=product_info&products_id=282
- 41g: Toggler. (2009). *Toggler*. Retrieved December 24, 2009 from <http://www.toggler.com/plastictogglevideoHome.swf>

Figure 43: *Prototyping base connection concepts*.....72

Innovative	Prototype		
43a	43d	43g	43j
43b	43e	43h	43k
43c	43f	43i	43l

- 43a: Reference Figure 41 d.
- 43b: Reference Figure 41 a.
- 43c: PPOL:News. (2006). *Quick release*. Retrieved December 24, 2009 from <http://www.ppolnews.com/?id=82177&keys=Recalled-Shimano-Quick-Release>
- 43d-43p: Bowie, C. (2009). *Prototype investigation*. Original photograph.

Figure 45: *Methods of raising and lowering sails and flags*.....76



45a: Getty images. (n.d). *Man raising sail on boat*. Retrieved January 20, 2010 from <http://www.gettyimages.com/detail/200192363-001/Stone>

45b: The Piedmont Chapter of the Georgia Society. (2007). *Raising the flag*. Retrieved January 20, 2010 from <http://www.piedmontsar.com/activities-2007.html>

Figure 46: *Collapsible clothesline*.....76

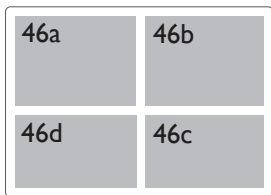

46a: Trade Me. (2010). *Clothesine, Rotary, Hills, Large size, Ex Cond*. Retrieved January 20, 2010 from <http://www.trademe.co.nz/Home-living/Laundry/Clothes-lines-racks/auction-266495252.htm>

46b: Paton, B. (2009). *Clothesline*. Original photograph.

46c: Paton, B. (2009). *Clothesline detail*. Original photograph.

46d: Trade Me. (2010). *Hills Rotary Hoist Clothesline*. Retrieved January 20, 2010 from <http://www.trademe.co.nz/Home-living/Laundry/Clothes-lines-racks/auction-266186180.htm>

Figure 47: *Mechanical hoist*.....77



47a: Sri Kamadhenu Enterprises. (n.d.). *Mechanical Hoist*. Retrieved January 20, 2010 from <http://www.indiamart.com/srikamadhenu/industrial-pumps-gensets.html>

47b: Lift Turn Move. (n.d.). *Wall Mounted Rack and Pinion Jack*. Retrieved January 20, 2010 from <http://www.liftturnmove.co.uk/jacks Rack Pinion Wallmount ed.html>

Figure 48: *Bevel pinion mechanisms*.....77

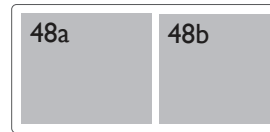

48a: How Stuff Works. (n.d.). *Gear bevel*. Retrieved January 20, 2010 from <http://static.howstuffworks.com/gif/gear-bevel.jpg>

48b: Hills. (n.d.). *Repair Kit 8bms Original Supa*. Retrieved January 20, 2010 from <http://www.onlinedirect.hills.com.au/cattleprod/products/A3310RKO>

9.2 Table Index

Table 5: Case study analysis.....34

Criteria for PMS Case 2	MC1	Container House	Factor Shack	Wee House	Eco Nomad	ES	Stik
	5a	5b	5c	5d	5e	5f	5g
Reference							
Level of technological knowledge required							
Transfer of people required for installation							
ES1							
Design for disassembly/reassembly/transport							
Structural strength (100 degree rotation)							
Aesthetic value							
Cost							
Standard parts & materials used							
Structural strength							
Advantages							
Disadvantages							
Reference							
ES1 requires pre-fabricated components							
ES2 requires pre-fabricated components							
ES3 requires pre-fabricated components							
ES4 requires pre-fabricated components							
ES5 requires pre-fabricated components							
ES6 requires pre-fabricated components							
ES7 requires pre-fabricated components							
ES8 requires pre-fabricated components							
ES9 requires pre-fabricated components							
ES10 requires pre-fabricated components							
ES11 requires pre-fabricated components							
ES12 requires pre-fabricated components							
ES13 requires pre-fabricated components							
ES14 requires pre-fabricated components							
ES15 requires pre-fabricated components							
ES16 requires pre-fabricated components							
ES17 requires pre-fabricated components							
ES18 requires pre-fabricated components							
ES19 requires pre-fabricated components							
ES20 requires pre-fabricated components							

- 5a: Micro Compact Home. (2005). *Micro Compact Home*. Retrieved January 12, 2010 from http://www.microcompacthome.com/pics/start_1.jpg
- 5b: Alsbach-Stevens, P. (2007) as referenced by TreeHugger (2008). *The container house exterior*. Retrieved January 12, 2010 from <http://www.treehugger.com/files/2008/04/shipping-container-house-ross-stevens.php>
- 5c: Carter E. (2001). *Future Shack*. Retrieved April 18, 2009 from <http://www.seangodsell.com/>
- 5d: Alchemy Architects. (2003). *Arado weeHouse*. Retrieved January 12, 2010 from <http://www.weehouse.com/#Arado>
- 5e: OCETA Eco-Nomad. (1999). *Eco-Nomad combined utility container*. Retrieved January 12, 2010 from http://www.oceta.on.ca/profiles/economad/economad_tech.html
- 5f: Villinski, P. (2008). *Emergency Response Studio exterior*. Retrieved March 12, 2009 from <http://www.emergencyresponsestudio.org/images.html>
- 5g: Bavaria charter. (n.d). *Bavaria cruiser*. Retrieved January 12, 2010 from http://www.bavaria-charter.com/yacht-charter-prices-majorca-7.1__en-bavaria~34cr-139_0.html

Table 6: Review of existing solar arrays.....37

Criteria	Solar Stik	Eco Nomad	Carterton mobile array	Emergency Response Studio	Container Array
	6a	6b	6c	6d	6e
Design					
Level of technological knowledge required					
Transfer of people required for installation					
ES1					
Design for disassembly/reassembly/transport					
Structural strength (100 degree rotation)					
Aesthetic value					
Cost					
Standard parts & materials used					
Structural strength					
Advantages					
Disadvantages					

- 6a: Really Natural. (2008). *Solar Stik portable solar array*. Retrieved November 11, 2009 from http://www.reallynatural.com/archives/alternative-energy/solar_stik_portable_solar_arra.php
- 6b: Bowie, C. (2009). *Eco Innovation solar array*. Original photograph.
- 6c: Bowie, C. (2009). *Carterton solar array*. Original photograph.
- 6d: Villinski, P. (2008). *Emergency Response Studio exterior*. Retrieved June 19, 2009 from <http://www.emergencyresponsestudio.org/images.html>
- 6e: Advance Solar. (2007). *Container array*. Retrieved November 11, 2009 from <http://www.advancesolar.ca/products.php?cat=systems>

Table 8: Appliance specifications.....43

Specifications	Refrigerator	Coolbox	Compressing Tubex
	8a	8b	8c
Product Name	Serada C501	Baumatic FG2SS	Ecophy
Dimensions w x d x h (mm)	400 x 390 x 640	288 x 510 x 50	863 x 635 x 635
Power Use	13W/hr	Au 7.2 W/hr	0.26kWh/day
Power Voltage/Source	120V/1	Gas	120V/1
Capacity	50 Litres	100	Full size 3 people - empty box array 3.4 weeks
Weight (kg)	10.7	3.1	20
Materials	Hard bonded mobile surface - matt black top surface	Stainless Steel	Plastic
Retail Outlet	Serada	Kitchen Things	Ecophy.com
Price (NZD)	\$1,567	\$329	\$1,980

- 8a: Serada. (2009). *C501 Refrigerator*. Retrieved March 26, 2009 from <http://www.serada.co.nz/>
- 8b: Kitchen Things. (n.d). *Baumatic FG2SS.2 Gas S/S*. Retrieved March 26, 2009 from <http://www.kitchenthings.net.nz/catalogue.html?sid=52>

8c: Eco John. (2009). *Eco John Basic-1 2*. Retrieved March 27, 2009 from <http://ecojohn.com/catalog/basic-series-brochure.pdf>

Table 9: Electrical system components.....46

Specifications	Solar Panel	Batteries	Solar Controller	Transformer	Generator	Efery Meter
	9a	9b	9c	9d	9e	9f
Product Name	Mitsubishi Electric PV-MF100EC4	Exide RP121200	Outback FlexMax60	Transformer/Rectifier	Honda EU2000	E-Reader
Number Required	4	4	1	1	1	1
Dimensions (w x d x h, mm)	646 x 1422 x 54	518 x 276 x 242	140 x 40 x 100	300 x 300 x 50	290 x 510 x 425	100 x 80 x 20
Power (Collected/Output)	100W collected per panel	n/a	n/a	n/a	20kW	n/a
Lifespan	30 years	10-20 yrs depending on maintenance	10-20yrs	10-20yrs	7-8yrs (for warranty)	20yrs
Retail Outlet	Eco Innovation	Eco Innovation	Eco Innovation	Eco Innovation	NGare Technologies	Eco Innovation
Price (NZD)	\$1,000/panel	\$600/battery	\$1,200	\$750	\$1,600	\$100
Additional Info	1.5kg/panel Coulomb meters	6kg	64 day data logging LCD	n/a	n/a	n/a
Electrical System Component Cost	\$10200 (approx) + gas canister and gas bottle					

- 9a: Mitsubishi. (n.d.). *Mitsubishi electric PV MF100EC4*. Retrieved November 11, 2009 from <http://www.bdt.co.nz/solar/product.asp?item=754101>
- 9b: Lynkos. (2002). *Exide battery*. Retrieved April 18, 2009 from <http://www.lynkos.cz/content.php?l=en&index=2113#top>
- 9c: Eco Innovation. (2007). *FlexMax 60 solar controller*. Retrieved April 26, 2009 from <http://www.ecoinnovation.co.nz/p-271-flex-max-60-solar-controller.aspx>
- 9d: Eco Innovation. (2007). *Transformer/rectifier*. Retrieved April 26, 2009 from <http://www.ecoinnovation.co.nz/p-241-12kw-transformerrectifier-pack-for-1224-vdc.aspx>
- 9e: Happy productions. (2004). *Honda 2000 watt generator*. Retrieved December 26, 2009 from <http://www.happyproductions.com/images/equipment/slides/Honda%202000%20watt%20Generator.html>
- 9f: Eco Innovation. (2007). *Efery meter*. Retrieved December 24, 2009 from <http://www.ecoinnovation.co.nz/p-465-efery-meter.aspx>

Table 10: Energy system overview.....47

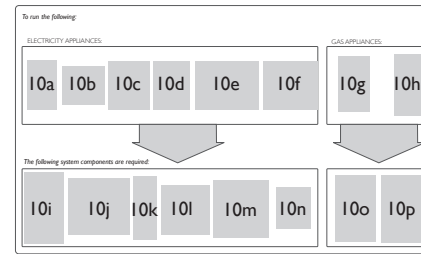

- 10a: Ultrashock. (2003). *Lightbulb*. Retrieved December 26, 2009 from <http://www.ultrashock.com/forums/photoshop-battles/lightbulb-weekly-05-09-a-124338.html>
- 10b: *C50l Refrigerator*: reference Table 8a.
- 10c: Chicargoland Television. (2009). *Cellphone*. Retrieved December 26, 2009 from <http://weblogs.ctv.com/features/health/livinghealthy/2009/09/can-cell-phones-cause-cancer.html>
- 10d: *Eco John Basic-1 2*: reference Table 8c.
- 10e: Apple. (2009). *Macbook Pro*. Retrieved December 26, 2009 from <http://www.apple.com/macbookpro/>
- 10f: Gadget Speak. (2007). *Logitech portable speakers*. Retrieved December 26, 2009 from http://www.gadgetspeak.com/gadget/article.rhtm/755/437852/Logitech_Speaker_system_for_the_Apple_ip.html
- 10g: *Baumatic FG2SS.2 Gas S/S*: reference Table 8b.
- 10h: Bombay Harbor. (2008). *Shower head*. Retrieved December 26, 2009 from http://www.bombayharbor.com/productImage/0855103001228617048/Shower_Head.jpg
- 10i: *Mitsubishi electric PV MF100EC4*: reference table 9a.
- 10j: *Exide battery*: reference table 9b
- 10k: *FlexMax 60 solar controller*: reference Table 9c
- 10l: *Transformer/rectifier*: reference Table 9d
- 10m: *Honda 2000 watt generator*: reference Table 9e

- 10n: *Efergy meter*: reference table 9f
- 10o: Sella. (2009). *Challenger califont lpg water heater*. Retrieved December 26, 2009 from <http://www.sella.co.nz/general/building-renovation/plumbing-gas/water-cylinders-heaters/54h87j/>
- 10p: 101 Dermnations. (2009). *Gas bottle*. Retrieved from <http://101dermnations.blogspot.com/2009/04/why-cant-we-all-just-be-friends.html>

Chapter Ten Glossary

Biomimicry	Using ideas from nature to inspire human solutions.
Generator	A machine that converts mechanical energy into electrical energy and used as back-up when the weather is not favouring solar panels and producing energy.
Grid-tied	Solar electric systems that are capable of feeding power to the grid (or utility company).*
ISO	International Organisation for Standardisation
Inverter	A device that converts direct current (DC) produced by solar modules to alternating current (AC).*
kW	A unit used to measure power.*
OEM	Original equipment manufacture
Off-the-grid	A term used to describe a system that runs on renewable energy sources independent of a public utility grid.
PAB	Port-a-Bach
PAB Gen-2	Port-a-Bach Generation-2
Psychographic	Attributes relating to personality, values, attitudes, interests or lifestyles. ¹
PV	Photovoltaic: a solar cell made up of semiconducting material which absorbs sunlight to produce energy.*
Solar controller	Controls and prevents batteries from overcharging.
Solar panel	Photovoltaic device which converts light into electricity.*
Transformer	A device that transfers electrical energy from one circuit to another
V	Voltage: the rate at which energy is drawn from a source that produces a flow of electricity.*
W	Watts: used to measure power.

* Borrego Solar. (2008). Glossary. Retrieved January 20, 2010, from <http://www.borregosolar.com/resources/glossary.php>

¹ Wikipedia. (2009). Psychographic. Retrieved January 20, 2010 from <http://en.wikipedia.org/wiki/Psychographic>

7,000BC: Bedouin Tents
Pastoral nomadism begins: tents are made from hand spun and woven goat hair.



25BC: Roman Contubernium
The contubernium was the smallest unit of soldiers in the Roman Army. The unit shared a tent made from large goatskins.



1700AD: Ottoman Turkish tent
Ornate tents that were derived from yurts usually decorated elaborately in colourful textiles.



1870: America's First Mobile Homes
These were built as movable beach-front properties in North Carolina. Teams of horses were used to move the homes.

1892: Prefabrication begins
Ernest Franklin Hodgson created a prefabricated system for small structures like chicken coops, tool sheds and a summer cottage.

1908: Houses by Mail
Sears Roebuck & Co. established a mail order system and sold 100,000 units before its demise in 1940.



1923: Building Blocks
Walter Gropius develops a standardised system of housing for a series of houses for the Bauhaus Masters. The aim was to put the building block construction elements into practice for efficient assembly.



1929: Dymaxion House
Buckminster Fuller presents his earliest concept for his round metal house. The house was designed to be factory manufactured and assembled on site, suitable for any environment and resource efficient.



1934: Airstream
The aluminium 'sausage' shaped vehicles were the only recreational ones to survive the Depression, though industry faced an aluminium shortage. At the end of World War II, when veterans returned home, homes were in short supply. Trailers evolved into 'Mobile Homes' to provide quick, cheap housing.



1947: Prefab for Vultex Aircraft Co.
Industrial designer Henry Dreyfus and architect Edward Larrabee Barnes work together to design a prefabricated house for Vultex Aircraft Company. The outcomes consisted of paper core panels skinned in aluminium.

7,000BC - 1700AD

1700-1890

1910

1930

Design Developments

The earliest form of portable housing was tents - these were made from materials available at hand. Animal hair and skins were the most appropriate natural resources for this application.

Many early varieties of tents were hand stitched carefully on the inside to prevent rainwater penetration at the seams.

With the progression of the Industrial Revolution came mass manufacturing causing rapid production of products from concept to creation.

Prefabrication became a more viable option for both small and large-scale buildings with the benefits of reduced costs and a reduced timeframe.

Developments in materials eventuated with prefabricated housing. Iron and steel was experimented with and utilised more often.

One-off buildings were rare but exceptional examples of the magnitude to which materials could be manipulated.

The introduction of the automobile enabled individuals to gain more independence. The Airstream had the same effect and also embodied a sense of optimism and adventure. The Airstream contained a small kitchen, electric lighting, independent water supply and slept up to four people.

Figure A1. Portable housing evolution - Part One (Bowie, 2009)

— 1954: Marshfield Homes 'Ten Wide'
Ten-Wide crossed the line between vehicle and house by developing a 3m wide (10ft) trailer. The Ten-Wide was a house. You could get special permission to take a Ten-Wide on the road.

— 1966: Winnebago

The Winnebago: the beginning of 'RVing'. It used an assembly line that brought costs down to nearly half the cost of competing RV's.



— 1967: U.S. Pavilion - Buckminster Fuller

Fuller designs a large prefab geodesic dome for the Montreal World Expo, which goes on to become a prefab icon.



— 1970: Modern Camping Tent

Development of new materials enabled revised construction and design resulting in better stability and lightweight frames.



— 1976: National Mobile Home Construction & Safety Act

The United States Congress passed the act to ensure homes were built to rigid, approved construction standards. They also approved to changing the term 'Mobile Home' to 'Manufactured Home'.

— 1985: Single and Double Wide

Deborah Burke develops two modular house designs. The Single Wide house has 1,100sq feet of living space while the Double Wide house has 1,700sq feet.

— 1996: Bo Klok - IKEA

The Swedish company, renowned for its affordable, mass manufactured modern furniture branched into prefabricated homes. The homes are built in modules and then delivered to site.



— 2005: Micro Compact-Home

A compact dwelling for 1-2 people. Living space is 2.6m³ and can be transported via truck or helicopter. Designed for short stay living i.e. students.



— 2007: Port-a-Bach

A second hand shipping container, retrofitted to sleep four. Can be opened on arrival, connected to mains services within 5 minutes.



— 2008: Emergency Response Studio

The ERS is a portable artists studio with integrated technology to be independent of mains services.



1950

1970

1990

2010

The Ten Wide was completely built in the factory and driven to site.

The Winnebago combined automobile and RV as one spacious unit including kitchen, lounge and room to sleep five.

RVs became popular American icons with a sense of freedom.

The evolution of lightweight, durable materials bought a revised concept of camping back into the market. Modern tents are designed to stand freely and can overcome inclement weather. Modern tents eliminate the need for tools by using components that snap together. This enables the user to quickly assemble/disassemble the tent.

Prefabrication lost its momentum after the post World War II homes started to deteriorate several years later. However, with revised material choices, it has once again become a desired method of construction. IKEAs prefabricated homes use better quality materials, take less time to build than conventional homes and have varying degrees of customisation.

Sustainability is at the forefront of many modern portable buildings. Use of recycled materials is often evident, particularly for the exterior which is also often used for other functional aspects. Modern portable buildings are often designed for semi-permanent use and are small scale, lightweight and easily transported.

Figure A2. Portable housing evolution - Part Two (Bowie, 2009)

Appendix 11.2

Appliance investigation: refrigerator





		C42LPXF - Standard		C501		C42LIXPF		C45LXPF	
									
Selection Criteria	Weight	Specification	R / WS	Specification	R / WS	Specification	R / WS	Specification	R / WS
Energy Use	25								
Power Voltage	5	12/24	5 25	12/24	5 25	12/24	5 25	12/24	5 25
Nominal Input (watts)	10	30.5	8 80	38.5	7 70	30.5	8 80	30.5	8 80
Average Consumption	10	10.5 W/H	9 90	13 W/H	8 80	10.5 W/H	9 90	10.5 W/H	9 90
Size/Weight	20								
Dimensions (w x d x h)	10	380 x 370 x 520	3 30	400 x 390 x 640	3 30	395 x 362 x 545	3 30	390 x 400 x 540	3 30
Capacity (litres)	6	40	4 24	50	5 30	40	4 24	45	5 30
Weight (kg)	4	15.8	3 12	15.7	3 12	15.8	3 12	16.1	3 12
User interaction	20								
Safe to use	10	Good	10 100	Good	10 100	Good	10 100	Good	10 100
Level of User Experience	10	Good	8 80	Good	8 80	Good	8 80	Good	8 80
Aesthetic qualities	20								
Suitable aesthetic	8	Good	6 48	Good	6 48	Good	6 48	Good	6 48
Quality materials	7	Good	5 35	Good	5 35	Good	6 42	Good	5 35
Cooling Unit (int. pref.)	5	External	2 10	Internal	5 50	External	2 10	External	2 10
Manufacturing & Cost	15								
Made in New Zealand	6	No	0 0	No	0 0	No	0 0	No	0 0
Price	9	\$1,385 + gst	4 36	\$1,393 + gst	4 36	\$1,634 + gst	3 27	\$1,387 + gst	4 36
Total Score			570		596		568		576
Rank			4		1		5		2

Figure A3. Refrigerator matrix - Part One (Bowie, 2009)

		KF130-11			C41			Otamatea Eco Village Fridge			Fridgetech Elite		
													
Selection Criteria	Weight	Specification	R / WS		Specification	R / WS		Specification	R / WS		Specification	R / WS	
Energy Use	25												
Power/Voltage	5	12/24	5	25	12/24	5	25	0	5	25	12/24	5	25
Nominal Input (watts)	10	n/a	0	0	30.5	8	80	0	10	100	n/a	0	0
Average Consumption	10	222 kWh p/a	10	100	12 W/H	9	90	0	10	100	n/a	0	0
Size/Weight	20												
Dimensions (w x d x h)	10	563 x 600 x 850	1	10	610 x 385 x 400	5	50	Customise	10	100	Customise	10	100
Capacity (litres)	6	130L	6	36	18L	1	6	Customise	6	36	Customise	6	36
Weight (kg)	4	n/a	0	0	18	3	12	Depends on size	4	16	Depends on size	4	16
User interaction	20												
Safe to use	10	Good	10	100	Average	5	50	Average	5	50	Good	7	70
Level of User Experience	10	Good	10	100	Bad	2	20	Bad	4	40	Average	5	50
Aesthetic qualities	20												
Suitable aesthetic	8	Good	8	64	Bad	2	16	Good	6	48	Good	6	48
Quality materials	7	Good	7	49	Average	4	28	Good	7	49	Good	7	49
Cooling Unit (int. pref.)	5	Internal	5	25	Internal	5	25	Freeze water daily	1	5	Internal	5	25
Manufacturing & Cost	15												
Made in New Zealand	6	No	2	12	No	0	0	Yes	6	6	Yes	6	36
Price	9	\$1,190	5	45	n/a	0	0	n/a	0	0	\$4,000+ (400mm ²)	1	9
Total Score			566			402			575			464	
Rank			6			8			3			7	

Figure A4. Refrigerator matrix - Part Two (Bowie, 2009)

Refrigeration

Criteria for Port-a-Bach Generation 3 Refrigerator:

Energy Use

- 12/24 volts
- Low nominal input

Size/Weight

- Dimensions: depth 400mm maximum
- Capacity: enough to store essentials i.e. milk, meat.
- Inclusion of freezer unit
- Weight: as light as possible CS

User Interaction

- Safe to use
- High level of user experience

Aesthetic qualities

- Suitable aesthetic to integrate comfortably into Port-a-Bach interior
- High quality of materials used for long life and durability
- Internal cooling unit preferable for space

Manufacturing & Cost

- Made in New Zealand ideally
- Price: as low as possible for high quality product

Refrigeration Comparison:

Most residential homes install refrigerators to run off electricity, however for motor

GRAM

	<ul style="list-style-type: none">▪ GRAM refrigerators are extremely energy efficient: all are energy rated from between 4 ½ - 6 stars.▪ Simple design enables these refrigerators to fit into most interiors▪ Flexibility in interior compartments allows each user to configure their own fridge arrangement▪ Manual thermostat control▪ 214 kWh p/a
-----------------------------------------------------------------------------------	----------------------------------------------------------------------------------------------------------------------------------------------------------------------------------------------------------------------------------------------------------------------------------------------------------------------------------------------------------------------------------------------------------

Figure A5. Gram refrigerator. (Eco Innovation, 2006).

FRIDGETECH

	<ul style="list-style-type: none">▪ FRIDGETECH is a New Zealand company specializing in custom-made refrigerators.▪ Plywood outer shell: marine contexts▪ Internal adjustable shelving▪ Foam thickness customized▪ Energy consumption varies depending on size
-----------------------------------------------------------------------------------	------------------------------------------------------------------------------------------------------------------------------------------------------------------------------------------------------------------------------------------------------------------------------------------------------------------

Figure A6. FridgeTech refrigerator. (FridgeTech, 1997).

homes and caravans that are on the move or travelling to remote locations, often gas is more suitable.

The disadvantage of using gas, is that gas stations are required to fill up bottles and these are not always easily accessed. Most refrigerators can run off either electricity or gas. The purpose of the refrigerator comparison is to select the most appropriate fridge for the Port-a-Bach and to decide on the power source.

Safety Considerations:

Most refrigerators are safe and healthy to use. A gas run refrigerator is considered more dangerous than an electrical refrigerator due to running a constant open flame.

State of the Art Refrigeration: see figures A5 & A6.

Product-Scoring Matrix

The product-scoring matrix is a process that enables quick product comparison of relative qualities. The purpose of the matrix is to rank the products using suitable criteria that are relevant to the Port-a-Bach Generation 3 project.

The selection criteria are given weightings relative to their importance and then scored based on each rating and given a ranking. For qualitative criteria a performance based rating applied. Good, Average and Bad are ratings that can be easily awarded and quickly compared to the other products.

Please note when reading product-scoring matrix:

R rating

WS weighted score

n/a not applicable: information requested by not supplied

New Zealand made products:

Local refrigerators from companies such as Fisher and Paykel were taken into consideration as options, however initial comparisons of dimensions and styles were not suitable for product-scoring matrix.

Summary of selected refrigerator: features and benefits

The highest scoring refrigerator was the C501. This refrigerator best fits the criteria prescribed by Atelier Workshop for the Port-a-Bach Generation 3.

The C501 refrigerator has a capacity of 50 litres including a small freezer space. An internal cooling unit means no extra storage space in the Port-a-Bach kitchen will be taken up with the cooling fan unit. The C501 is a conventionally designed refrigerator and therefore most people will be comfortable interacting with it.

Many motor homes and caravans utilise the C501 refrigerator around New Zealand.

Appendix 11.3

Appliance investigation: electric cooktop





		Broadwater 3000-2 Burner w Grill		Broadwater T2H-2 2-Burner		Rinnai RETKRL 2 Burner Hotplate		Induction Hotplate	
									
Selection Criteria	Weight	Specification	R / WS	Specification	R / WS	Specification	R / WS	Specification	R / WS
Energy Use	20								
Power Voltage/Source	10	12/24 or gas	10 100	12/24 or gas	10 100	Gas	5 50	12/24	5 50
Power Use (kW)	10	n/a	0 0	n/a	n/a	8 MJ/hr per burner	9 90	2kW	3 30
Size	15								
Dimensions (w x d x h)	8	440 x 320 x 165	4 32	420 x 325 x 125	4 32	557 x 375 x 132	4 32	350 x 350 x 50	7 56
Economical for bench space	7	Bad	1 7	Bad	1 7	Bad	1 7	Good	7 56
User interaction	25								
Safe to use	10	Average	5 50	Average	5 50	Good	8 80	Good	8 80
High level of User Experience	10	Bad	2 20	Average	5 50	Good	8 80	Good	8 80
Two hobs	5	Yes	5 25	Yes	5 25	Yes	5 25	No	0 0
Aesthetic qualities	25								
Suitable aesthetic	13	Bad	2 26	Average	6 78	Average	8 104	Average	8 104
Quality materials	12	Good	12 144	Good	12 144	Average	10 120	Good	11 132
Manufacturing & Cost	15								
Made in New Zealand	6	No	0 6	No	0 0	Yes	6 36	No	0 0
Price	9	\$670.87	5 45	\$547.36	5 45	\$257	8 72	\$249.99	8 72
Total Score			455		531		696		660
Rank			7		5		2		3

Figure A7. Electric cooktop matrix - Part One (Bowie, 2009)

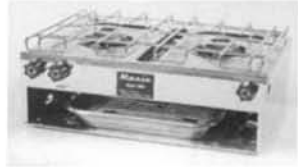

		Smev 2 Burner Hob Drop In SAI600AGA		Gaggenau Vario 21 Induction Hob		Miele CSI2121	
							
Selection Criteria	Weight	Specification	R / WS	Specification	R / WS	Specification	R / WS
Energy Use	20						
Power Voltage/Source	10	Gas	5 25	12/24	5 25	12/24	5 50
Power use (kW)	10	n/a	0 0	3.6	2 20	3.7kW	2 20
Size/Weight	15						
Dimensions (w x d x h)	8	480 x 370 x 90	7 56	380 x 520	8 64	272 x 500	8 64
Economical for bench space	7	Good	7 49	Good	7 49	Good	7 49
User interaction	25						
Safe to use	10	Average	5 50	Good	9 90	Good	9 90
High level of User Experience	10	Average	5 50	Good	9 90	Good	10 100
Two hobs	5	Yes	5 25	Yes	5 25	Yes	5 25
Aesthetic qualities	25						
Suitable aesthetic	13	Bad	4 52	Good	10 130	Good	13 169
Quality materials	12	Good	10 120	Good	11 132	Good	12 144
Manufacturing & Cost	15						
Made in New Zealand	6	No	0 0	No	0 0	No	0 0
Price	9	\$713 + gst	6 54	\$3,199	1 9	\$2,399	2 18
Total Score			481		634		729
Rank			6		4		1

Figure A8. Electric cooktop matrix - Part Two (Bowie, 2009)

Electric Cooktop

Criteria for Port-a-Bach Generation 3 Cooktop:

Energy Use

- Power voltage/Source
- Power use (kW)

Size

- Dimensions: bench allows for a maximum 400mm depth
- Economical for bench space: does it sit flush with bench and can it be used as extra space

User Interaction

- Safe to use: consideration of children
- High level of user experience
- Two hobs

Aesthetic qualities

- Suitable to sit comfortably into the Port-a-Bach interior
- High quality of materials for long life and durability

Manufacturing & Cost

- Made in New Zealand
- Price

Cook-top Comparison:

There are large ranges of cooktops on the market today including electric, ceramic, induction or gas. Each has its own features and benefits and the product comparison is aimed at selecting the most appropriate cooktop for the Port-a-Bach to decide on the power source.

Consideration for a safe cooktop:

Cooktops are designed with safety in mind, and most are childproof and safe to use. Electric, ceramic and induction hobs differ to gas in that they do not display an open flame. However this is usually safe if the user is experienced.

State of the Art Cooktops:

Induction cooktops are the cheapest cooktops to run and the most efficient to run. While gas is also efficient, induction technology is more advanced with regards to efficiency.

Induction has an efficiency rate of 80%, compared with 43% for gas and 44-53% for other electric technologies. Savings of up to 30% can be achieved by using induction heating, however magnetically sensitive cookware must be used.

Product-Scoring Matrix

The product-scoring matrix is a process that enables quick product comparison of relative qualities. The purpose of the matrix is to rank the products using suitable criteria that are relevant to the Port-a-Bach Generation 3 project.

The selection criteria are given weightings relative to their importance and then scored based on each rating and given a ranking.

For qualitative criteria a performance based rating applied. Good, Average and Bad are ratings that can be easily awarded and quickly compared to the other products.

Please note when reading product-scoring matrix:

R rating

WS weighted score

n/a not applicable: information requested by not supplied

GAGGENAU INDUCTION (CERAMIC)

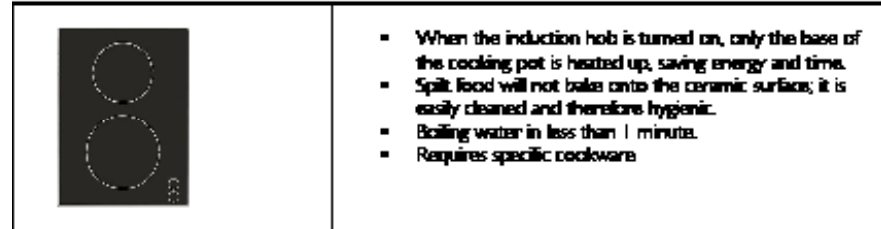

Figure A9. Gaggenuau ceramic cooktop. Retrieved January 20, 2010 from http://www.gaggenuau.com/AP_en/products/modular-cooktops-overview/product-detail.do?contentId=daf1e70a-72b5-4235-9846-306370b99f7d&family=Vario

MIELE : GAS

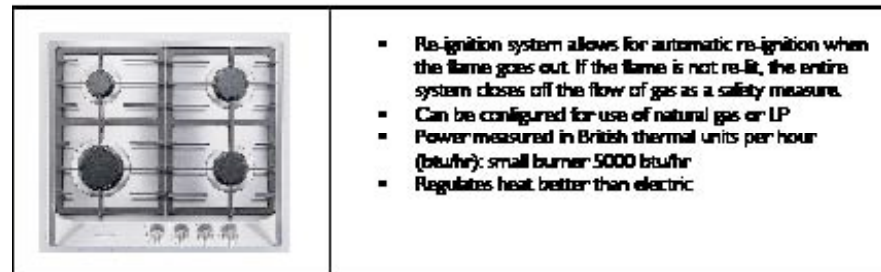

Figure A10. Miele gas cooktop. Retrieved January 20, 2010 from <http://www.mieleusa.com/usa/cooking/cooktops/product.asp?cat=3&subcat=11&model=146&series=34&nav=20&snv=110&tnv=150&T=197>

MIELE : ELECTRIC

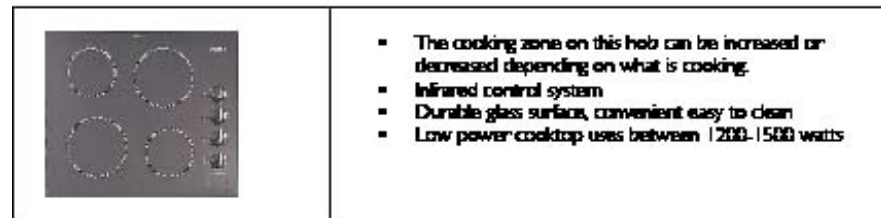

Figure A11. Miele electric cooktop. Retrieved January 20, 2010 from <http://www.mieleusa.com/usa/cooking/cooktops/product.asp?cat=3&subcat=11&model=74&series=12&nav=20&snv=110&tnv=150&T=197>

New Zealand made products:

Local cook-top products from Fisher and Paykel and Rinnai were taken into consideration as options. The Fisher and Paykel models were deemed unsuitable for the Port-a-Bach after being reviewed by initial criteria, specifically due to their dimensions.

Summary of selected cook-top: features and benefits

The highest scoring cook-top was the Miele CSI2121. The New Zealand made Rinnai gas cooker was the second scoring cook-top however the Miele presented a more energy efficient solution. Selecting an induction cook-top to be installed in the Port-a-Bach requires planning and consideration particularly since the Port-a-Bach Gen 3 is off the grid. Therefore the number of batteries must be considered when carrying out a load analysis.

Inclusion of an induction cook-top also requires use of magnetically sensitive cook-ware.

The benefit of using induction is that it is a one time set up and does not require refilling of gas bottles.

The Miele is one of few induction cook-tops that provide two hobs that was a key element in the criteria. With clear knobs for safety and ease of use, and dimensions to suit, the Miele hob also includes a safety switch to prevent overheating.

A power rating of 3.7kW is also a considerable energy input however far less than most options and this is only when running on high on both elements.

The stainless steel plate and flush cooking surface ensures cleaning is easy and that the element fits in with the sleek Port-a-Bach interior without being over the top for a 'bach' context.

Appendix 11.3.1

Appliance investigation: gas cooktop





		Rinnai RETKRL 2 Burner Hotplate		Baumatic FG2SS		Smeg PDXF30R		Gaggenau Vario VG232	
									
Selection Criteria	Weight	Specification	R / WS	Specification	R / WS	Specification	R / WS	Specification	R / WS
Energy Use	20								
Power Voltage/Source	10	Gas	10 100	Gas	10 100	Gas	10 100	Gas	10 100
Power Use (kW)	10	8 MJ/hr per burner	9 90	6.4 MJ/hr	10 100	7.2 MJ/hr	9 90	4.7kW	4 40
Size	15								
Dimensions (w x d x h)	8	557 x 375 x 132	4 32	312 x 580 x 73	7 56	288 x 510 x 50	8 64	288 x 510 x 55	8 64
Economical for bench space	7	Bad	1 7	Good	6 42	Good	7 49	Average	5 35
User interaction	25								
Safe to use	10	Good	8 80	Good	10 100	Good	10 100	Good	10 100
High level of User Experience	10	Good	8 80	Good	10 100	Good	10 100	Good	10 100
Two hobs	5	Yes	5 25	Yes	5 25	Yes	5 25	Yes	5 25
Aesthetic qualities	25								
Suitable aesthetic	13	Average	8 104	Good	11 143	Good	13 169	Good	13 169
Quality materials	12	Average	10 120	Good	12 144	Good	12 144	Good	12 144
Manufacturing & Cost	15								
Made in New Zealand	6	Yes	6 36	No	0 0	No	0 0	No	0 0
Price	9	\$257	8 72	\$1,499	3 27	\$329	8 72	\$1,699	2 18
Total Score			836		837		913		795
Rank			3		2		1		4

Figure A12. Gas cooktop matrix (Bowie, 2009)

Gas cooktop

Criteria for Port-a-Bach Generation 3 Cooktop:

Energy Use

- Power voltage/Source
- Power use (kW)

Size

- Dimensions: bench allows for a maximum 400mm depth
- Economical for bench space: does it sit flush with bench and can it be used as extra space

User Interaction

- Safe to use: consideration of children
- High level of user experience
- Two hobs

Aesthetic qualities

- Suitable to sit comfortably into the Port-a-Bach interior
- High quality of materials for long life and durability

Manufacturing & Cost

- Made in New Zealand
- Price

Revised look at Cooktops:

After calculations were presented for the initial load analysis, it was clear that it was far exceeding what was expected. This was due to the selection of two of the appli-

ances: the heat pump and the induction hobs. To run these appliances the Port-a-Bach Gen 3 would require at least ten solar panels.

After re-evaluating the load analysis and changing the induction hobs for gas and eliminating the heat pump, the Port-a-Bach Gen 3 could run off four solar panels. Not only is this a far cheaper option, but is also considerate of resources.

The Port-a-Bach concept is a simplified living concept, and the overall design aesthetic is one that involves little distraction from the building itself. To install ten or more solar panels would overwhelm such a small building, so with this in mind, Atelier Workshop, and myself decided to use a gas cook-top.

How cost effective is gas?

Utilising gas in the Port-a-Bach Gen 3 requires installation of a gas califont. This is cheap and reliable technology ideal for a small living unit. A family of four, would be able to live off one 9kg bottle of LPG for cooking in a month, the cost of which is approximately \$30.

Consideration for a safe gas cooktop:

Gas cooktops are open-flame appliances and this is often seen as a benefit to users. Open flames are highly visible and so it is easy for a user to recognise whether an element is on or off. Other cooktops such as ceramic and induction, use lights to indicate the level of heat.

Product-Scoring Matrix

The product-scoring matrix is a process that enables quick product comparison of

relative qualities. The purpose of the matrix is to rank the products using suitable criteria that are relevant to the Port-a-Bach Generation 3 project.

The selection criteria are given weightings relative to their importance and then scored based on each rating and given a ranking. For qualitative criteria a performance based rating applied. Good, Average and Bad are ratings that can be easily awarded and quickly compared to the other products.

Please note when reading product-scoring matrix:

- R rating
- WS weighted score
- n/a not applicable: information requested by not supplied

New Zealand made products:

Local cooktop products from company Fisher and Paykel were taken into consideration as options, however did not meet the criteria for the dimensions.

Summary of chosen cooktop: features and benefits

Space saving is vital in the Port-a-Bach Gen 3. The Smeg 2 burner gas cook-top was the most energy and space efficient. It sits flush with the bench which allows for the space to be utilised as continued bench space while cooking.

With clear and easy to handle knobs, the cooktop is safe to use. Stainless steel ensures that the hobs are easy to keep clean and also ties into the modern, sleek interior of the Port-a-Bach Gen 3.

Appendix 11.4

Appliance investigation: composting toilet





		Compact		Kiwibog		Ecojohn Basic Series		Model 9010	
									
Selection Criteria	Weight	Specification	R / WS	Specification	R / WS	Specification	R / WS	Specification	R / WS
Energy Use	20								
Power Voltage	12	12/24	12 144	12 and 230V	12 144	12/24	12 144	12/24 or 120V AC	12 144
Power use (watts)	8	n/a	0 0	1/hr	8 64	0.26 kW/day	8 64	2.5	6 48
Size	5								
Dimensions (w x d x h)	5	n/a	0 0	n/a	0 0	863 x 635 x 635	3 15	465 x 672 x 541	4 20
User interaction	25								
Safe to use	7	Good	7 49	Good	7 49	Good	7 49	Good	7 49
Hygienic to empty	12	Good	10 120	Good	9 108	Good	10 120	Good	10 120
Intuitive to use	6	Good	4 24	Good	3 18	Good	4 24	Good	4 24
Aesthetic qualities	10								
Suitable aesthetic	10	Average	5 50	Bad	2 20	Average	5 50	Average	5 50
Environmental Consideration	25								
Quality materials	7	Good	7 49	Good	7 49	Good	7 49	Good	7 49
Energy use	8	n/a	0 0	Good	8 64	Good	8 64	Good	6 48
Suitable waste consideration	10	Good	8 80	Good	8 80	Good	8 80	Good	9 90
Manufacturing & Cost	15								
Made in New Zealand	6	No	0 0	Yes	6 36	No	0 0	No	0 0
Price	9	\$2,764	3 27	\$1,200	5 45	\$1,982	4 36	n/a	0 0
Total Score			543		637		695		642
Rank			4		3		1		2

Figure A13. Composting toilet matrix (Bowie, 2009)

Composting Toilets

Criteria for Port-a-Bach Generation 3 Composting Toilet:

Energy Use

- Power voltage
- Power use (watts): inclusion of a fan

Size

- Dimensions (w x d x h)

User interaction

- Safe to use
- Hygienic to empty: separation of urine and solid waste
- Intuitive to use

Aesthetic qualities

- Suitable aesthetic

Environmental Consideration

- Quality materials: for long life and durability
- Energy use
- Suitable waste consideration

Manufacturing & Cost

- Made in New Zealand
- Price

State of the Art Composting Toilets:

Based on research into this small market, it seems that there is much scope for development in the area of composting toilet design.

The range of composting toilets is few and far between, especially when looking locally. There are several varieties including waterless, incinerating and self-contained toilets, the most ecologically sound method being a self-contained unit (so long as the waste is disposed/used appropriately).

Consideration for a safe composting toilet:

Safety for composting toilets includes a high level of hygiene when emptying and disposing of the contents. There are a variety of composting toilets that now separate urine and solid waste into two separate compartments so that they can be handled individually. This allows for urine to be utilised on compost if that is the intention of collection as it is a fantastic source of nitrogen. Solid waste on the other hand, can be stored until it dries and decomposes thoroughly and can then be used as a fertilizer.

Product-Scoring Matrix

The product-scoring matrix is a process that enables quick product comparison of relative qualities. The purpose of the matrix is to rank the products using suitable criteria that are relevant to the Port-a-Bach Generation 3 project.

The selection criteria are given weightings relative to their importance and then scored based on each rating and given a ranking.

For qualitative criteria a performance based rating applied. Good, Average and Bad are ratings that can be easily awarded and quickly compared to the other products.

Please note when reading product-scoring matrix:

R rating

WS weighted score

n/a not applicable: information requested by not supplied

New Zealand made products:

Currently the New Zealand made 'Kiwibog' is the only composting toilet made in New Zealand. In terms of product semantics, the 'Kiwibog' most resembles a regular toilet. In conversation with Don Smith from Kiwibog, he mentioned that, "the Kiwibog has been designed to New Zealand and Australian standards however has not yet been tested and confirmed." (Smith, 2009)

Summary of selected composting toilet: features and benefits

The EcoJohn Compacting Toilet excelled in the area of hygiene because the system has been developed to minimize human interaction, which in the case of this product is crucial.

This composting runs a fan to assist with decomposition and odour eradication and is very light on energy intake that is important. The methods of emptying the waste include ways of re-using the waste in an effective and healthy approach.

Although the aesthetics of the product leave a little to be desired, it can be integrated into a built context to conceal the bulky storage compartment at the back of the toilet.

Load analysis

SP Energy[®] Worksheet Copyright 2009 **Elemental energy**

This sheet is for customers who are NOT connected to mains electricity supply

Customer Details

Name: Charlotte Bowle
 Site Address: For every site (mass manufactured small portable building)
 Postal Address: 212 Taranaki Street, Wellington, New Zealand
 Phone: 04 384 6688 Mobile: n/a
 Email: charlottebowle@gmail.com
 Preferred Contact: Email
 Site Images/ Plans Attached: YES

System Details

Desired System Type: Stand Alone
 Preferred Renewable Generation: Solar
 Is there an existing Generator: NO
 Additional existing Generator information: NO
 Mains Power Connection: NO
 Quotation for Mains: \$
 Cooking: Electric
 Hot Water System: Solar
 Would you like a quote on a Solar Water Heating System?: YES
 Existing Water Pump: NO
 Existing Effluent Pump: NO
 Water Supply Source: Roof water collection
 Bore Depth: 0
 Bore Volume Available: 0
 Source Notes: collection depending on vertical lift to tank (m) Bore ID (From council or driller)

Please select this Solar Pumping Request option below if you ONLY wish to pump water from your renewable power solution.
 Solar Pumping Request: NO Volume Required (m3 P/Day): 0

Site Details

Site Type: New build
 Location - Latitude: North facing
 Location - Longitude: <3m away?
 Possible location for mounting PV panels: <3m away?
 Distance from WIND Turbine to Power System (m): <3m away?
 Roof Material: container
 Prevailing Wind (direction): Average Speed (km/hr): collect
 Hydro - Head (m): Flow (l/s): Pressure (psi):
 Distance from HYDRO Turbine to Power System (m): NO
 I would like Remote Monitoring & Diagnosis: NO
 I would like on site service response contract: YES
 Site & Load Audit Desired?: YES
 Notes: Please see pdf document for extra information about the design of the port-a-bach

Load Analysis

House Details
 House Size (m²): container
 Number of Bedrooms: 1
 Number of Showers: 1
 Number of Baths: 0
 Number of People (normally living at home): 4
 Number of Guests: 0
 Hot Water Cylinder (make, model & volume): n/a
 Purpose of Property: Bach

Item Description and Make/Model	Qty(l)	Watts (amps x volts)	Hours per Day	Days per Week
Entry Foyer & Hallways				
Heater(s)				
Lighting(l)				
Laundry				
Washing Machine	Qty(l)	Watts	Hours per Day	Days per Week
Dryer				
Lighting				
Bathrooms				
Heated Towel Rail(v)	Qty(l)	Watts	Hours per Day	Days per Week
Underfloor Heating				
Hairdryer				
Extractor Fan				
Heat Lamps				
Lighting				
Composting toilet	1	0.26kW/day		7
Bedrooms				
Electric Blankets	Qty(l)	Watts	Hours per Day	Days per Week
Waterbed				
Bedside Lights	4 small		4	7
Alarm Clock(y)				
Heater(s)				
Lighting				
Item Description and Make/Model				
Lounges/Family/Living Areas				
TV				
Stereo	1	not specified	2	7
DVD Player				
Game Console				
Sky Decoder				
Video Player				
Laptop/Computer	1	not specified	2	7
Heater				
Lighting	4 strips	not specified	4	7
Kitchens				
Fridge	1	13 WH	24	7
Freezer (chest or upright)				
Electric Oven	1	3.7kW	3	7
Rangehood/Extractor Fan				
Microwave				
Dishwasher				
Kettle				
Toaster				
Blender				
Breadmaker				
Electric Wok				
Coffee/Espresso Machine				
Waffle Iron/Toasted Sandwich Maker				
Lighting				

Figure A14. Load analysis (Elemental Energy, 2009)



Figure A16. What cars end users might drive. (Bowie, 2009)

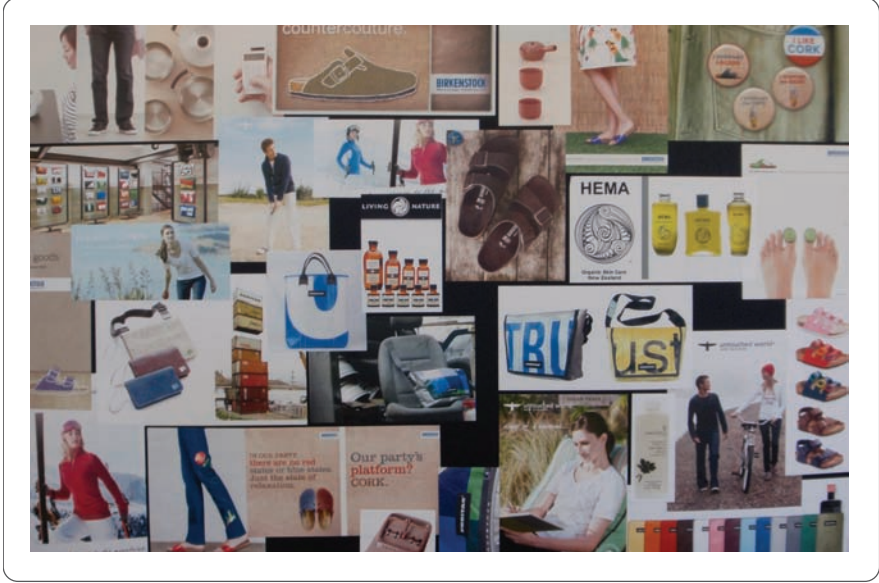

Figure A18. What clothing and products end users might buy. (Bowie, 2009)



Figure A17. What food and alcohol end users might buy. (Bowie, 2009)

Appendix 11.8 Semi-structured interviews: notes & results

Semi-structured interview with Stan Abbott

10.30am: Thursday April 2nd, 2009

Director of the RoofWater Research Centre

Massey University, Room 3C12

Water use per person in:

Wellington: 400L/person/day

Auckland: 150L/persn/day

Issues:

- Steel surface for drinking water
- Use of second hand containers means you don't know where they have been or the condition they will be in; jeopardizes the chance of rain water collection for drinking
- Storage: bladder is good, otherwise elevated tank: Don't want it to be an eyesore
- Work with what you can store
- Toxic paints used on containers?

Design concepts:

- Use of awning to collect water?
- Stand alone water collectio device
- Consider how to deal with overflow...spread the water across the land (as if it were raining) rather than erode the landscape by pouring it all onto one spot

Semi-structured interview with Michael Lawley

1.30pm: Friday April 3rd, 2009

Renewable Energy Engineer

EcolInnovation

671 Kent Road

R.D.1, New Plymouth, NZ

Ph: 06 752 2765

Introduction:

- Masters on a design that architecture company atelier workshop have developed: The Port-a-Bach; working on the development of an 'off the grid' Generation 3 version
- Location: general design with modular consideration for adaptability for individual landscapes
- Most interest has currently been 'bach' buyers but also huge commercial interest particularly from film industry
- East end open with bunks is being revised; end will be permanently closed; still aiming to sleep four
- Stage we are at now; decided on appliances for interior; load analysis; looking at suitable renewable energy component configurations

Design aspects:

- location of components: integrated into port-a-bach or separate system
- assembly of components
- packaging of components (in portable situation; i.e. film sets)
- possible new water storage system

Desired outcomes:

- solar water heating yes/no
- solar water storage tank size for 4 people (150L/2 people?)
- water storage: bladder? raised tank? tank with pump?
- 240V vs 12V: International voltage? International requirements?
- wind turbine yes/no
- diesel generator yes/no
- integrated system into the 20ft port-a-bach possible: yes/no
- separate unit including items that need maintenance: yes/no
- solar panels recommended
- solar laminate (picture) yes/no
- LED lighting (vs T5 dimmerable linear fluorescents: Rexell?)
- renewable energy system that can be set up by the 'purchasers'; elemental energy have a product where basically once the components are assembled all the 'users' need to do is connect a plug...realistic?yes/no?

Appliances:

- Fridge (with tiny freezer space) 13 W/H
- Induction hobs 300kWhrs/day
- Composting Toilet - low 0.26 kWhrs/day: 12V fan; 2W max
- Lighting (4 strips on south wall): 20W max (3 hours/day)=60Whrs/day
- Bedside lighting (4 small bedside)
- Stereo: 30W (1W when off):
- Laptop: 50-75W
- Heat pump/air conditioning: NO, design well, neither required
- Cell phone charger: Low
- Front deck opening (generator?): 12V, run off gen easy
- Water pump?: Look at motor homes; 12V
- LCD TV: 12V or movies on laptop

Questions:

- 1| Do you think solar heating is a viable option for this type of architectural arrangement?
- 1a| Solar hot water system? [Mark recommends flat plate collectors with simple thermosiphon (no phase change material) because of simplicity and long life.]
- 2| (If yes); What is the general size of a solar water tank required for four people?
- 3| What method of water storage does the Port-a-Bach Gen 3 lend itself to?
- 4| The Port-a-Bach is a comfortable living arrangement for people who can afford to live in an architecturally designed shipping container therefore we are thinking of running a 240V system so that all the usual appliances can be used. Do you think a 240V system is suitable for the Port-a-Bach Gen 3?
- 5| Wind turbines obviously need specific landscapes in which to work effectively - is it wise for us to include one on the Port-a-Bach? - would it be more sensible to allow for integration if required/desired by 'users'?
- 6| Diesel generator is a safer option; yes/no?
- 7| Are there any examples you know of that integrate off-the-grid systems into living spaces similar to this? Is it a wise/healthy strategy? Or are we better off having a completely separate system? Location of generator; outside away from house; noisy, vibration etc.
- 8| Is there any effective technology you have seen that advances current solar panel technology that you would recommend?
- 9| How do you see this product working with 'users' manually assembling the system?
- 10| Are there any 'green' building guidelines you know of that if adhered to can be rated accordingly? If so, what are they? Green Star?
- 11| Safety of batteries: location in relation to living areas, food, sealed, plug through to generator....

Load analysis:

- 2 people: Good: 300-500kW
 Bad: 1kW

Outcomes of semi-structured interview with Michael Lawley

April 3rd 1.30-3.30pm

Construction:

- 2 x 10m containers with deck in between: 10m structures do not need permits, can avoid consent
- two single beds: could configure pop-out structure similar to those used in caravans, motor homes, VW Kombi's etc
- Did you know? That off-grid homes do not require insulation: building inspector told Michael Lawley
- Plastic: consider that when buying or designing products that using plastic from the USA will not last the same way in New Zealand

Appliances:

- Have we considered phone and internet? Wireless can be hooked into system however it runs continuously at 30W and runs 24 hours a day; enlarges system (p-a-b would need 5-6 panels)
Michael has it, turns it off in the evening so it only runs 12 hours a day.

Cooking:

- Get rid of induction: 4 panels vs 10 panels.
- Gas for cooking and water heating: califonts are cheap, reliable and most people would use no more than \$20/month of gas.

Refrigerator:

- Refrigerator: Stecca: 12/24V direct. Can be powered off a 180W panel, can even put it on deck (as opens upward which is what makes it more efficient).

Composting Toilet:

- Power usage is nowhere near 10W: more like 2W

Installation:

- Ensure logging device is installed. This requires the users to document their energy usage and is KEY when checking for problems (i.e. the system won't work, we ran out of power....check usage and shows they have been plugging in high power consuming appliances i.e. hairdryers)
Product called efergy: little white product shows your power usage inside home
- Weekly log sheet: measures the charge and helps with warranty issues

System:

- Maintenance over 10 years: \$2,500 every 10 years.
- Approximation of \$500 depreciation/year
- Up to 50V AC power: MUST be set up by an electrician to get code of compliance. P-a-b: get all wired up so that once on site, plugs together to work. Once plugged in on site, and wants to move p-a-b, can unplug and code of compliance carries with the p-a-b. Need an electrician to fix up the wires on site that p-a-b has moved from.
- To avoid prescribed compliance, run at 12V
- Electrician needs to install an earth peg, on site at location

Configuration:

- Trailer concept: if it's on a device that can be driven away for maintenance

it means a serviceman doesn't need to drive all the way out to the middle of nowhere to fix something

Generator:

- Generator size: small, eco-throttle, 1-2kW: Mitre 10 Mega. Can purchase really cheap ones for as little as \$500. These ones produce 'dirtier' fuel but it doesn't matter if the system is linked from the generator: transformer: regulator:
- Do not go for auto-start: It's expensive and unnecessary. Use manual: Once a week, check batteries and if the hydrometer shows the marker below a certain level, top them up. Creates awareness.

Inverter:

- Inverter: Uses energy even when sitting: between 5-10W

Solar:

- Mid-angle sun: 35 degree latitude, summer (New Plymouth) Winter;; steeper; 45%
- To calculate angle: Latitude of location + 10 degrees for summer
- 10 degrees for winter
(These can vary between 3-4%)
- Solar panels are often stolen on remote sites because they are high value, easy to take. Install security fixings, lock tight system.
- Panels cost \$1,000 each for (80W panels)

Windmill:

- Airbreeze would be most suitable: however creates some noise and you wouldn't want it attached to the container itself
Windmill is not recommended as you should only even have one back up

for solar: and in the p-a-b case, it's a generator and this is required for opening and closing the deck and is a much more suitable option

Batteries:

- Require 3 days of battery storage
- 5-10m away from people (this is ideal)
- Must be sealed and have vents
- 12V vs 24V batteries: Depends on appliances you want to use.
- 4 batteries required to run PAB Gen-3 system

Water:

- If rainwater is collected off a surface than means it needs UV treatment, this uses power!!! Design using suitable material...
- Water pump: look at motor home pumps – use little power

Continued research:

- ReNew magazine April-June 2009 Issue: competition for container designs
- Check with atelier workshop as to whether they have got consent for the complete 20ft container design
- Eco Innovation website: Go to: HELP; INFO; ENERGY OPTIMISER

Semi-structured interview with Ross Stevens

7-8.30pm: Tuesday 7th April, 2009

Senior Lecturer, Victoria School of Architecture

Background:

The container house was a Masters project that was aimed at researching how things change through time: Stevens feels this is better explained in architecture than in Industrial Design. i.e What is the site of architecture? Vs the site of an object? Arch always has a site, a location.

Stevens:

- "You build architecture but architecture also builds you".
- Tried not to 'try too hard' when designing the container house – joins have been left exposed as details and details have been made using recycled materials.
- Tries to use the least resources possible for the building, and then tries to limit the resources required to make the house work (ongoing costs and requirements to as little as possible)
- Fractal theory: Whereby from close up there is as much information on an object as there is from far away
i.e. forest: leaf : both complex object/s containing masses of information
gib: gjb : no information
The brain needs information for stimulation, otherwise it shuts down. If it is presented with little information, it assumes it is time to relax/rest etc.
i.e. many office spaces, libraries
- " I'm about sustainable decadence"

Containers:

- Insulated container (Stevens used) cost \$6,000
- Standard reefer container uses one piece of aluminium the length of the container then welded to steel ends
- Stainless interior
- Ceiling is one sheet of white plastic which reflects slightly to give the impression of an enlarged space
- Acoustically terrible
- Thermal mass is great as a ready made shell for housing unit
- Absorbs heat and moves: sometimes up to an inch

Port-a-Bach Gen3:

- Do you want the look of the container to stay? Or do you want to conceal it and give a different look?
- Joints: have been made into details. This is where Stevens believes you are able to show your 'cleverness' and skill.
- All cut outs from structure: windows mainly, have been reused for their structural value on the decks
- Aluminium joinery attached to aluminium container is ideal as it expands and contracts at the same rate
- Mood: think of this before you start designing: what is the mood you want people to feel/get from using the products you design for the port-a-bach. If this is nailed, then you have done your job Why do people respond to the images of the Port-a-Bach? Because of the mood. Work with this mood.
- Design this version in mind of the environment, not off the users saving money
- What can you do with waste? Window cut outs – how can they be used? What kind of fun can you have manipulating them or keeping them as structural elements?

Semi-structured interview with Dave Launder

9-10.30am: Thursday 16th April, 2009

KTL Lighting, 22 Northpoint Rd, Plimmerton

LED's:

- With LED's, heat is the problem; must keep them cool to run properly; done by integration of heat sink; no more than 65 degrees
- Work on amp's not volt's put into them
- LED's output; 120L/W (lumen per Watt) compared with Incandescent; 15L/W
- LED's advantages; lack of toxicity; longevity; control better (quick to turn on), colour

LED's could be used in strips across Port-a-Bach, with aluminium extrusion to slot LED's into and then a 'diffuser' strip of frosted acrylic on top of it (to give similar aesthetic to current design). This however, will not produce enough light for entire building; worth looking into integration of down lights in main areas.

Wind Turbines:

- Small windmill at entrance; \$600 from Jaycar produces 200W
- Large turbine on hill; \$25,000 produces 1800W
- Noisy; would not want it on top of the container itself; vibration etc
- Look at Swift Turbines; \$15,000 ones around Te Papa and Odins building

Look at Marine versions, Jaycar versions. Small surface area as the larger they get, the more they need to be secured to the ground for stability.

Cannot install without some degree of practical knowledge.

Look at Eco Innovation website – they recommend best types. Well regarded.

Semi-structured interview with Jay Davis

Monday 20th April 3pm

NZero Technologies

Phone interview 021 146 0877

Generators:

Brands: Honda and Kawasaki: Easy to get parts for and are reliable

Diesel:

- Usually utilized on larger houses; i.e. 2-3 bedroom, more permanent environment

Petrol:

- Better for use in cold weather than diesel
- Can be run of LPG
- Cheaper
- Entry Level generators are sold at large outlets like Mitre 10 and Placemakers, bringing the price down

Compact Generators:

- Popular for coffee and juice carts as are small and petrol ones are quiet
- Harder to maintain and fix as parts are so tightly compressed, they are harder to get to
- Very quiet

Port-a-Bach Gen 3 generator size required:

- 2.5kW-3kW ample
- Approximate cost is \$1,600

Semi-structured Phone Interview with Paul Villinski

Emergency Response Studio

New York, USA

Thursday 18th June, 2009: 12.00am NZ: 8am NY

Q1. How is it that the solar array mounted once the ERS is on a suitable site? Is it simple enough for a regular person to assemble or does it require more practical knowledge?

- Anyone who is handy can put up solar panels so long as they are watched the first time to ensure the panels are installed correctly.
- The mounting system is a commercially available stock rack system that comes with panels.
- Villinski had to reinforce the structure (roof and walls) to allow for the weight of the panels. He attached a unistrap running lengthways down the roof so that the panels could be mounted to this.
- Panels weigh 45 pounds each. 9 x 180W panels = 500 pounds.
- Packing system is hinged: lift the panels up, hinge, slide bolt into place
- There would be huge benefits in designing more accessible product that could enable consumers to set up part of or their entire own off-grid system.

Q2. Can the panels be adjusted to maximize sun in summer and in winter? Can they rotate if the ERS is not South facing, to gain the best sunlight?

- Panels are at an average angle of 40 degrees which for New York is great.
- No holes to change angle as yet, however holes into the aluminium mounting system can easily be drilled to allow for this.

Q3. How is the wind turbine mounted? Again, is it simple enough for a regular

person to assemble or does it require more practical knowledge?

- The wind turbine needs three people to help mount it.
- It uses an old 28 foot high flagpole which was donated. Aluminium pipe at the top of the flagpole extends the pole from 28 feet to 38 feet high.
- The base is hinged off the front of the trailer.
- When moving the pole sits along the length of the trailer.
- Turbine is raised the same way you raise a mast: manually and clamps into place. Diagonal struts help hold the mounting system in place.
- For wiring: the wires run down the inside of the flagpole, and are connected to the batteries with screw connections, however if it were to be sold commercially, a plug connection would be installed.

Q4. How do the panels pack down for storage and travelling? Can they be dismantled and stored within the home safely?

- The panels fold down on the roof and side walls and are bolted in place
- The idea of keeping the panels set up is because they were difficult to get up and onto the FEMA trailer in the beginning so wanted to keep them attached.

Q5. Is there a covering you put over them? (If they are left on the exterior?)

- They are left exposed and still harness energy whilst on the move

Q6. Have you considered theft of panels?

- Not especially, however when it was exhibited in New Orleans, Villinski did consider the safety of the ERS, however the response was one of respect.
- Overall, the ERS is not a very secure structure. It needs to be looked after.

Q7. How does the wind turbine pack down and store?

- Alongside the trailer

Q8. How much energy does the ERS require to run appliances? [Port-a-Bach requires 3.13 AC kW/week.] What appliances are included in the ERS?

- Kitchen: Stove is gas (propane). Hot water is gas (propane). Fridge is a 2-way fridge so can be run off 110V or propane.
- Energy collected runs the lighting and all the power tools required to build the ERS. Lighting: 13W compact fluorescent bulbs.
- It would take about 100-150W to light the trailer: yet the capacity for storage is 6000W/hrs.

Q9. You have 8 batteries included? What type? (Sealed? Wondering about safety of batteries in a cooking area).

- Batteries weight 160 pounds each. 225 amp hour batteries. Included enough batteries so that if there is no sun/wind for 2-3 days, there is enough electricity stored.
- Electricity to run: lighting, music, power tools, computer and battery chargers.

Q10. Have you found that the wind turbine is really only effective in very barren and flat landscapes?

- It was most effective in Austin, Texas where there was high wind for about a week solid.
- The maximum output of the turbine is 400W. Maximum output for the panels is 1600W, so the turbine only collects a small fraction of the power.

Turbine requires winds of 28mph to collect power, which almost never happens (Villinski says).

- The solar panels contribute the most power however the turbine is a visually important and symbolic component of the ERS. It's almost 40 ft high and is an important visual component of the ERS. The structure has a 21st century spaceship kind of quality to it.
- Villinski has also retained the ability to fly a flag.

Q11. What type of wind turbine is it?

- SouthWest Wind Energy: Air-X.
- Commonly used on sail boats.
- 13/14 pounds.
- \$400 (US)
- Well-made with an integrated charge regulator built into it. Simple to wire. No vibration in trailer; pretty quiet, high pitch whistle.

Q12. How does the crank deck work? Is it manual or do you use a small motor?

- Manual crank with a cable winch. 8:1 gear ratio – takes about 2 mins to wind down. Runs through the winch, then a pulley and back.

Q13. Have you included a back-up generator? If so, what kind? [Petrol or diesel]. What size?

- Doesn't need one. Constantly has power and to date has not run out. However the ERS appliances mostly used are lighting and playing video's at exhibitions.

Q14. Have you used the ERS in a post-emergency setting as yet? Do you intend to?

- Not sure, needs more work. At the moment it's leaking and the floor is coming up. "When I bought it, it wasn't water tight. I had to do extensive repairs just to get it to ground zero."

Q15. Have people expressed interest in getting more of these produced for this purpose? Or for other purposes?

- Built as a thought provoking architectural piece and is being used to exhibit a lot, and has huge positive response from it.
- "The ERS was always intended to be a one-off piece used by me, and the assembly and set up of the energy system wasn't a priority for the project. Therefore there was not a lot of consideration when it came to attachments and the overall user-experience associated with energy system."

Appendix 11.9 Scenarios

Objective: 1) Identify issues of assembly of energy system when families use PAB
2) Identify assembly issues with two adults in good physical condition
3) To identify the number of components that need assembly; and to find out what can be eliminated by good design

Activity: The best way to look at objectives is to create stories to consider characters and any difficulties that may be encountered.

Scenario One

Task:

i.e. The Wilson family, Susie, John and their two children Pat and Jenny live in the suburbs of Christchurch and are off to the coast for their Easter school holidays. Once they load up the Range Rover, they end up leaving Christchurch in peak hour traffic, with a four hour journey to Mapua ahead of them.

Susie and John live a busy city life, and pride themselves on trying to leave as light a footprint as possible in the country they are so proud of, New Zealand. The coastal property is a place they can relax, in a quiet environment and spend some quality family time.

When the Wilson's finally arrive, it is nearing midnight. The children are asleep in the back seat and Susie and John decide the best thing to do is to get everyone off to bed and to set up the PAB power system in the morning.

As John opens up the PAB, he rolls out the solar system safely stored away in their portable unit onto the deck to enable the beds to be set up quickly and qui-

etly so as not to disturb Pat and Jenny.

After breakfast, John sets up the water harvesting tent for Pat and Jenny to go and play in while he and Susie set up the solar array and batteries.

Opt 1:

John adjusts the ladder to the side of the container and climbs up so that Susie can pass him the panels to assemble. Whilst John is assembling the frame for panels, Susie mounts the battery unit on the rear of the container and begins to load in the batteries and hook them together (unrealistic).

Once John has mounted the panels on the frame, he climbs down to feed the cord from the panels into the battery unit, to connect the components.

Once connected, the battery unit is closed and sealed and the inverter, regulator and charger/transformer are switched on so that the panels can begin harnessing energy!

Issues:

- a) 'Packaging of the components has been overlooked
- b) Ladder = weight, more fittings for fixing it securely
- c) Each individual piece for the framing must be passed onto the roof, before assembly can begin including panels themselves
- d) Assembly requires two people minimum
- e) To mount a battery unit requires 4 x 66kg batteries to be lifted and THEN connected = too heavy and too dangerous
- f) Connection between solar panels and batteries requires connection of panels via a wire, down to batteries: not realistic

Opt 2:

Susie and John lay out the solar array frame on the ground, and connect the necessary parts to form a solid structure. The ends are located into the sides of the container before mounting the solar panels.

Once panels are laid flat on top of the frame, they are clipped and secured and the wind up mechanism is ready for use. Susie winds the arm while John ensures the panels are arranged at the correct angle.

Once the panels are in place, the batteries stored under the floor are linked up with the solar array so that the energy can be stored.

Issues:

- a) 'Packaging' of components has been overlooked
- b) Solar array consists of many pieces
- c) Large pieces of metal for raising array would be heavy and cumbersome to lift and put in place
- d) Batteries indoors; possibly not safe
- e) Cord from solar panels to batteries runs down the rear of the container and then requires connection beneath the floor of the interior

Opt 3:

The solar shed is pushed into an appropriate location, secured and the cord plugged into the PAB.

Issues: Client is not interested in doing this.

Scenario Two

- Objective:* 1) To establish issues when PAB energy system requires assembly with one adult who also needs to watch over her two young children
2) To identify difficulties for a middle aged woman in average physical condition

Activity: By visualizing this scenario it will enable me to pinpoint areas that will need to be targeted in the design

Task:

Angela is a single 45 year old mother of two young boys. Angela lives in Auckland and has worked full time as an accountant since she left university when she was 23 years old.

Angela bought a Port-a-Bach Gen 3 for a section her grandmother left her in the Hokianga, as a place she and her two sons can retreat to when the busy life in Auckland gets too much for them. She specifically wants her boys to learn to live in an environment that is not reliant on the modern facilities everyday life provides.

Angela sees her boys every second week and tries to make it to the bach at least one weekend every couple of months.

By the time Angela picks the boys up from school, they usually arrive at the bach around 5pm. What Angela loves about the PAB is how easy it is, to transform from city life, to bush life in literally seconds.

While the boys busy themselves in the bush making a fort, Angela sets about setting up the energy system.

Opt 1a:

Alone; can't push/pull heavy items

Since Angela is a frequent visitor to her bach, she leaves the solar system set up. However when she first set up the independent energy shed, she needed friends of hers to come and help her, as the weight of the shed was substantial.

Her and her friend rolled the shed out of the bach down a ramp, and due to the puggy landscape, had to haul it up to a flatter, drier spot to secure the shed in a safe place.

Issues:

- a) Many people required for heavy work
- b) Shed needs to be on flat ground therefore must be shifted to higher ground = too labour intensive
- c) Long cord to connect shed to container required

Opt 1b:

Barely ever goes to bach;

Since Angela rarely has time to go to her bach, she purchased the independent energy trailer, so that when she does decide to head off there, she can attach the trailer to the car and take off. On arrival, all Angela needs to do is simply plug the shed to the PAB and the panels will begin to charge.

Issues:

- a) Locations inaccessible by car will not be suitable for this method
- b) Lifting trailer onto car alone can be difficult

Opt 2:

To mount the solar panels, Angela uses the locators on the PAB container to slip the adjustable mechanism into place. Each of the two panels slide into place and instantly lock. Once the panels are linked together, a wire from them can be fastened to the battery pack so that charging can begin.

Issues:

- a) Doors will remain closed so not an option for panels on open door
- b) Panels on front of deck is not ideal for safety of panels; damage will be easy

Opt 3:

Angela attaches the vacuum pump to the generator and switches it into reverse, to blow up the inflatable solar array.

She sets the array in front of the deck and locks it to the front of the deck for safety.

The solid structures built into the inflatable array enables Angela to single handedly clip the panels onto the front before securing them with an anti-theft device. Once the panels are linked by the wire through all four panels, Angela is able to plug the wire into the batteries, securely stored under the floor.

Issues:

- a) Inflatable has problems of deflation
- b) Who will have a vacuum?
- c) How would panels secure to soft fabric? In-built structure?

Outcome:

Similarities between people in Scenarios:

- Similar 'class' bracket; middle class, with the means for money for PAB and land for it
- All need to be transported to the PAB; via car/train etc
- All need to set up energy system on arrival, and require the means to put it away aswell

Appendix 11.10 Scale model storyboards for solar panel location

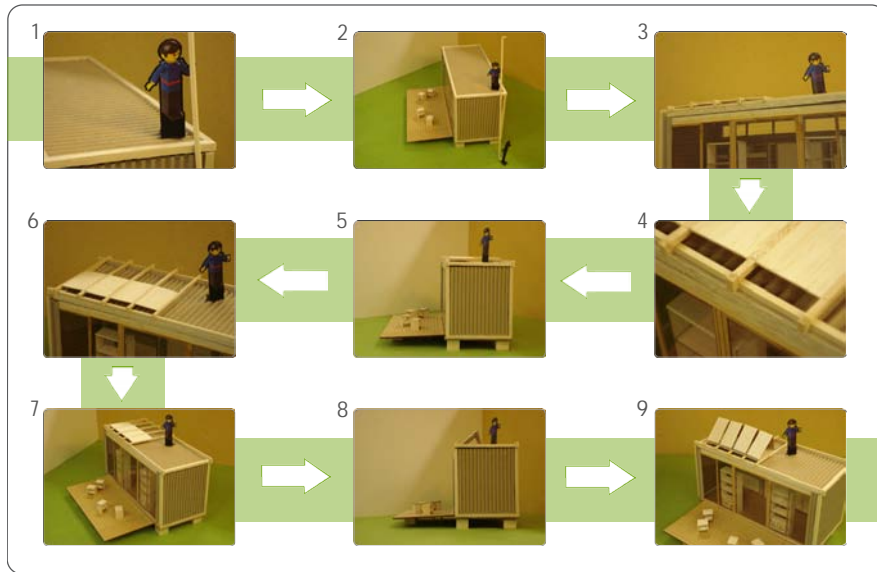

Figure A19. Rooftop solar array location concept. (Bowie, 2009)

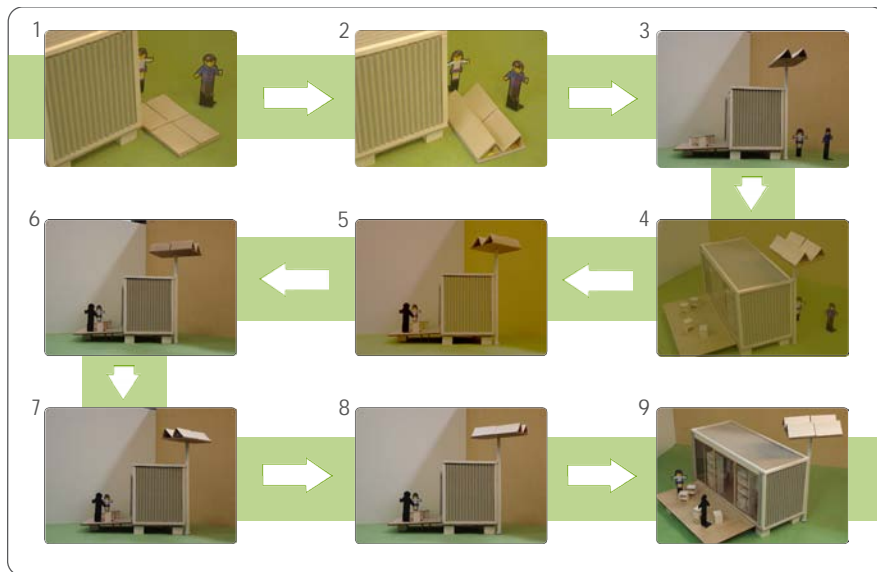

Figure A20. Gas sprung pole location concept. (Bowie, 2009)

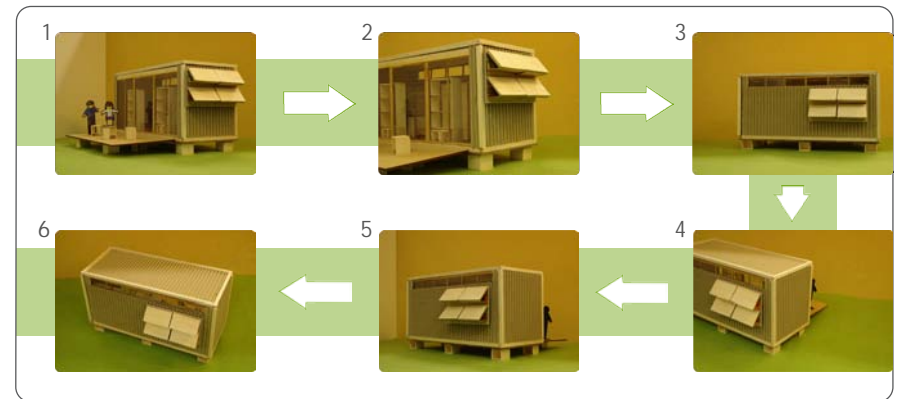

Figure A21. Consatina wall solar array location concept. (Bowie, 2009)

Solar panel location storyboards

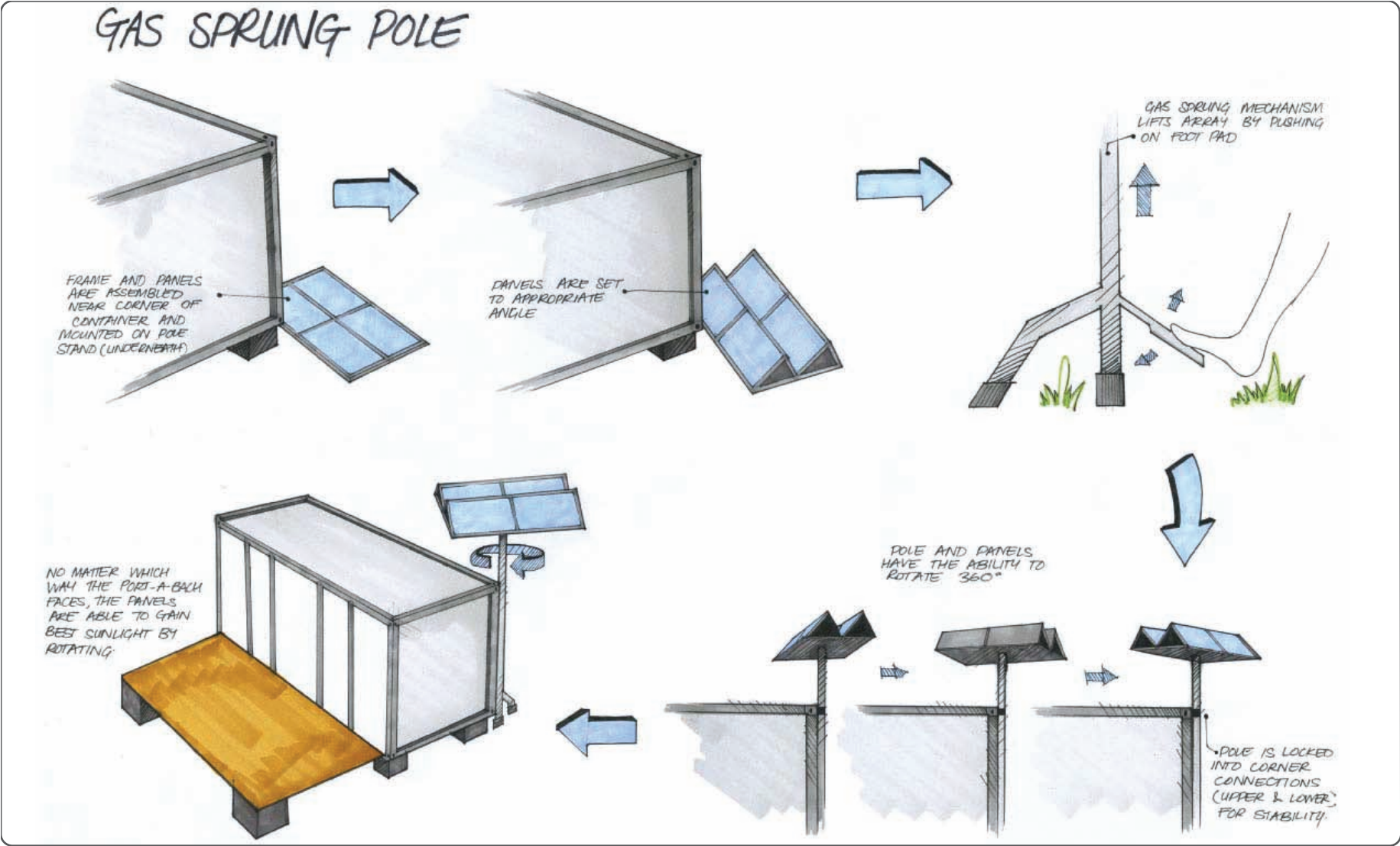

Figure A22. Gas sprung pole storyboard. (Bowie, 2009)

CONSATINA WALLMOUNT

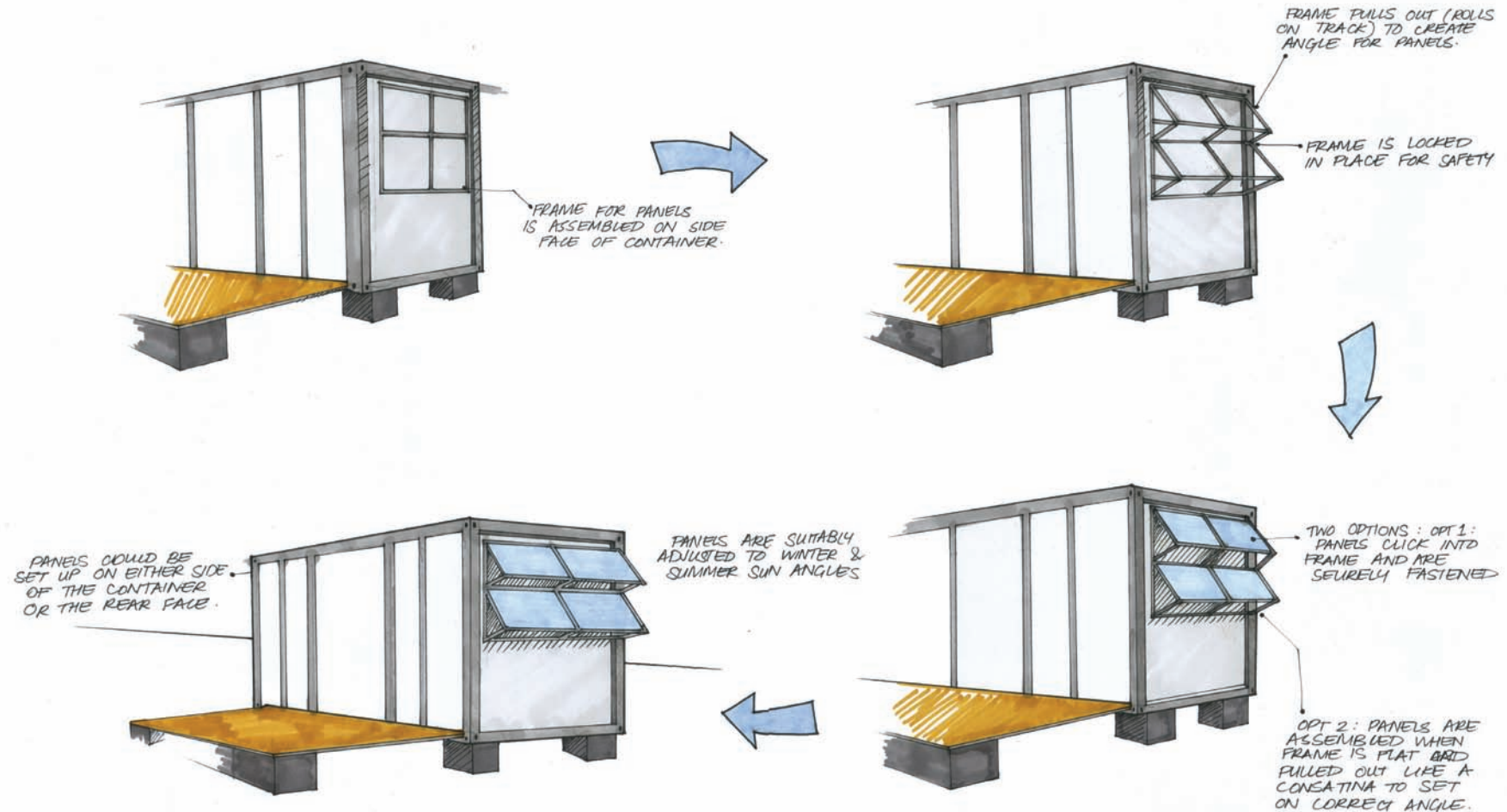

Figure A23. Consatina wallmount storyboard. (Bowie, 2009)

Design issues faced with rooftop solar panel locations

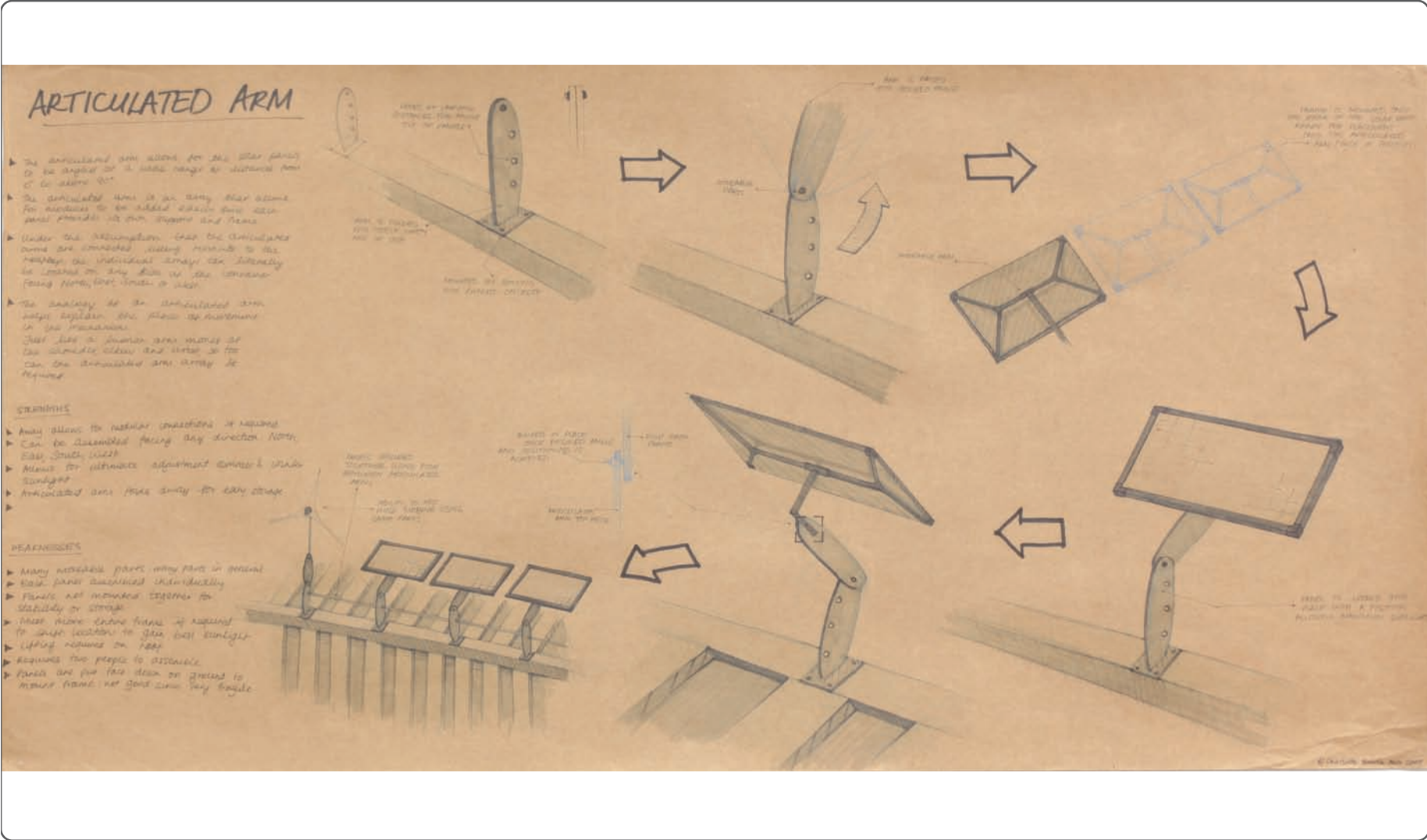

Figure A24. Articulated arm. (Bowie, 2009)

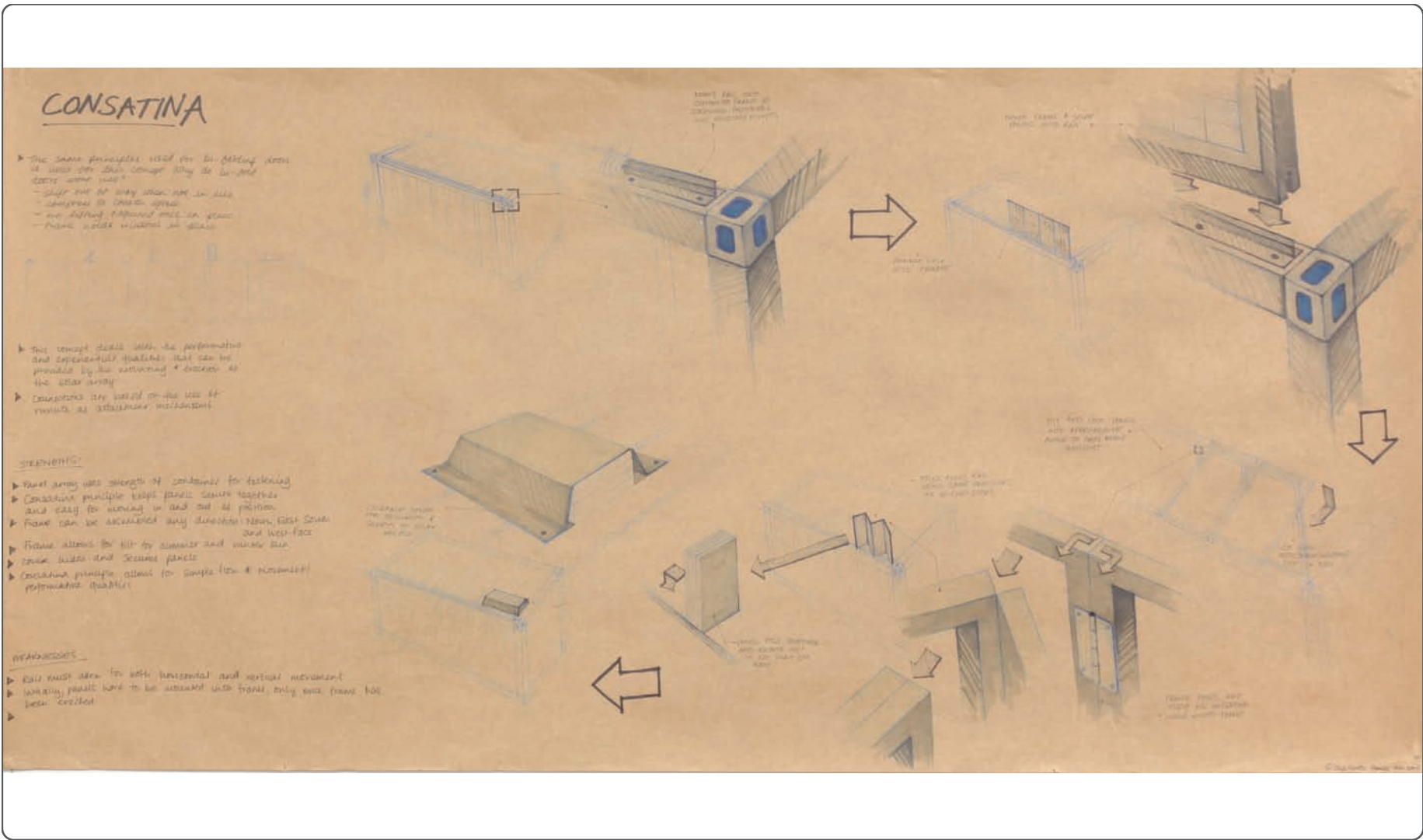

Figure A25. Consatina. (Bowie, 2009)

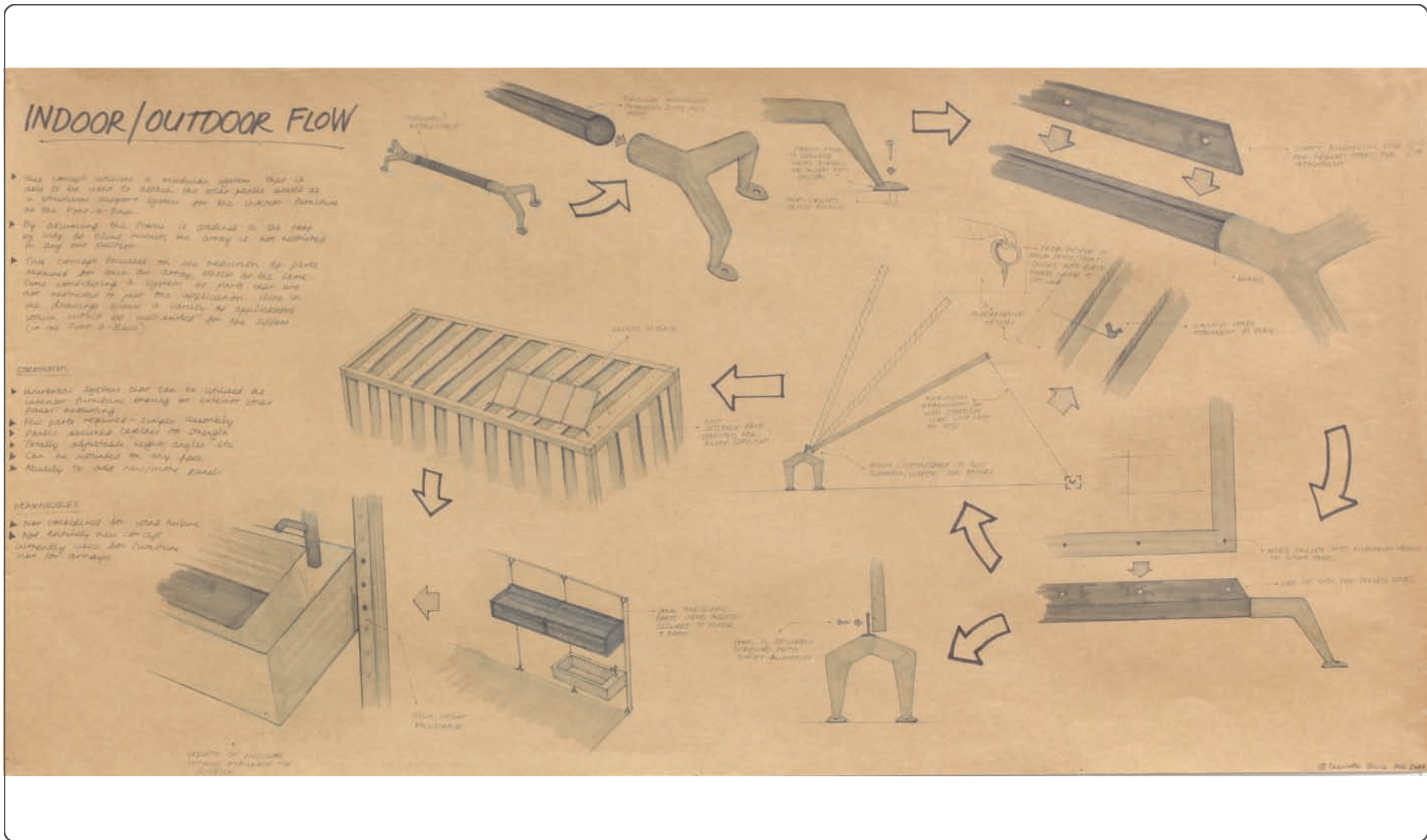

Figure A26. Indoor/outdoor flow. (Bowie, 2009)

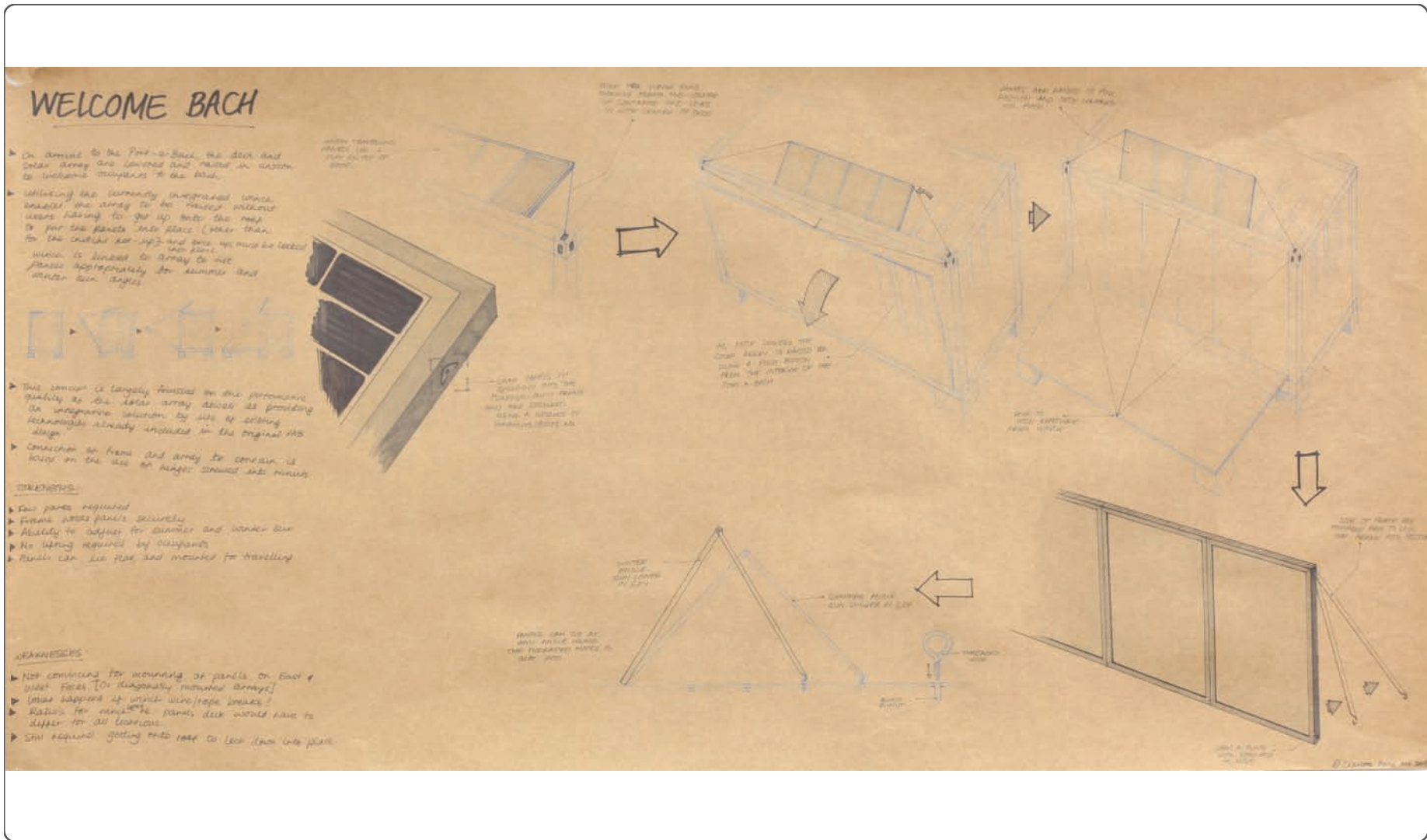
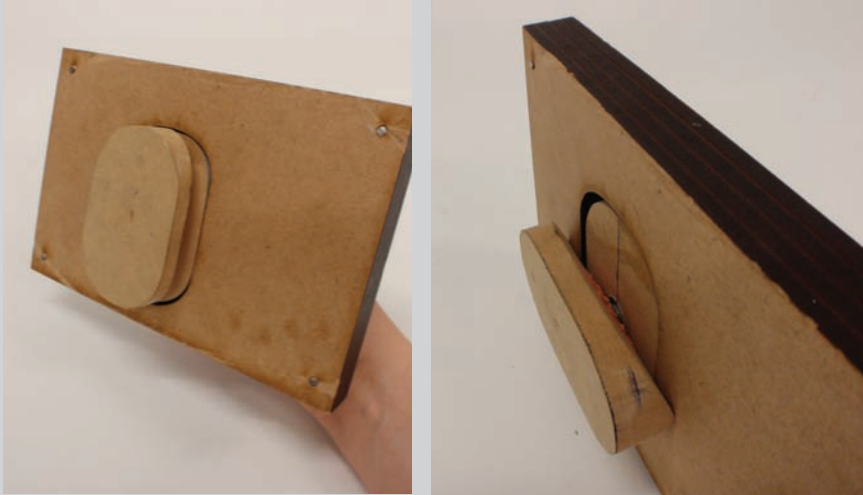

Figure A27. Welcome back. (Bowie, 2009)

Prototype Investigation

Raised rear plate with external spring tolerance:



Male/female rear plate mechanism:

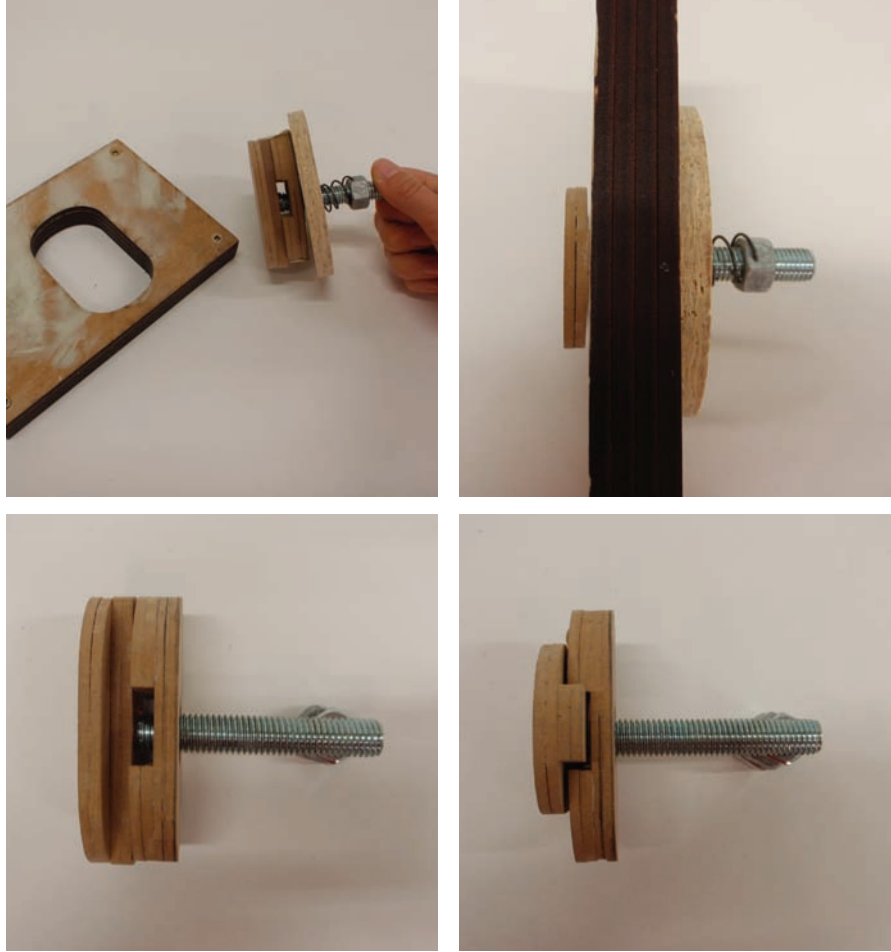

Figure A28. Wooden prototype investigations (Bowie, 2009).