

Copyright is owned by the Author of the thesis. Permission is given for a copy to be downloaded by an individual for the purpose of research and private study only. The thesis may not be reproduced elsewhere without the permission of the Author.

**The effects of on-farm mixing of bulls on beef quality
characteristics**

**A thesis presented in partial fulfilment of the
requirements for the degree of**

Master of Philosophy

**at Massey University, Palmerston North,
New Zealand.**

Julie Louise McDade, VMD

2010

Abstract

Some degree of stress is an inevitable part of the slaughter process for production animals. The degree of stress will vary due to a number of conditions over which there is sometimes no control. Stress levels may depend on such variables as familiarity of the animal to human contact and handling, temperament and even adverse weather conditions. Pre-slaughter handling has been identified as an area that can have adverse effects on both animal welfare and ultimately on meat quality characteristics.

Published information on the association between stress and meat quality, and more specifically, pre-slaughter handling and meat quality is reviewed. The physiological response of an animal to stress is examined, and the effect of the stress response on the resultant final product is presented. A detailed summary of the role of muscle glycogen both pre- and post-slaughter is also provided.

The main objective of the present study was to investigate whether on-farm mixing of bulls potentially plays a role in undermining meat quality characteristics. Thirty-three Friesian bulls between 18 and 24 months of age and weighing between 550 and 600 kilograms (live weight) were commercially slaughtered in January of 2010. These bulls were originally from one of seven finishing groups. The bulls were randomly allocated into one of three treatment conditions 1) control (no mixing), 2) mixing four days prior to slaughter or 3) mixing one day prior to slaughter. Blood was collected at slaughter and analysed for non-esterified fatty acids (NEFA mmol/L), plasma lactate (mmol/L), creatine phosphokinase (CPK IU/L). A sample of the longissimus muscle was collected approximately 20 minutes after slaughter. A portion of the sample was immediately snap frozen for determination of muscle glycogen concentration. Meat pH, shear force and drip loss was measured at 24 hours, 7 days and 28 days post-slaughter. Purge loss was calculated for the 7 and 28 day samples. Colour measurements were taken on bloomed and unbloomed samples.

By varying mixing times it was also hoped that the effect of recovery from mixing on-farm could start to be elucidated. It was a further objective that demonstration of an effect on meat quality could be used to encourage industry to adopt certain handling practices that could be communicated to their suppliers. A best practice model of pre-

slaughter handling on-farm would be the ultimate goal. This project represents only a starting point from which further research would be needed prior to development of best practice guidelines.

In the present study, concentrations of creatine phosphokinase (logCPK) in blood at slaughter for the 1 day mixed group was significantly higher ($p < 0.001$) when comparing the three treatment groups, which indicates that these animals were more physically active in the twenty four hour period prior to slaughter than the 4 day mixed or control animals. Mean CPK values for the 4 day mixed group were not significantly different from the control animals suggesting that by four days, the bulls had re-established a social order and physical activity had returned to a “normal” level. In terms of meat quality, the difference in CPK values is relevant when considering that at 28 days post slaughter, muscle tissue from the 1 day mixed bulls had increased shear force measurements ($p < 0.05$) when compared to the four day mixed and controls. CPK values and shear force data were found to be positively correlated in the present study ($p < 0.001$). CPK values were positively correlated with ultimate pH ($p < 0.001$) and negatively correlated with muscle glycogen concentration ($p < 0.001$).

Although not statistically significant ($p = 0.09$), the pH after 28 days ageing for the meat from the 1 day mixed animals was also increased when compared to the other two treatment groups. Meat from five animals had a pH greater than 5.8 after 28 days ageing. Three of the five were from the one day mixed group while the other two were from the four day mixed group. The highest pH at 28 days was 6.14, and this one day mixed animal also had the highest CPK at 15,756 IU/l. Not surprisingly muscle glycogen concentration from the 1 day mixed animals was lower than for the other two groups, and the significance followed the same trend ($p < 0.073$).

Results of the current study indicate that the chances of high-pH beef and the accompanying decrease in beef quality may be increased if bulls are mixed within 24 hours of slaughter. Based on the results more research into the effects of on-farm mixing is certainly warranted.

Acknowledgements

Firstly, I would like to acknowledge my Massey University advisors, Brian Wilkinson and Roger Purchas. Their advice and contributions have been considerable. I especially note that had Brian not initially recognized my enthusiasm during my first paper, I would never have even thought to embark on this journey. Together they have pushed me to give my very best.

I would also like to thank Eva Wiklund of The National Union of the Swedish Sami People, and Mustafa Farouk, Katja Rosenvold, and Pete Dobbie, of MIRINZ AgResearch, who very generously provided their time to assist with development of the trial protocol, obtain ethical approval as well as providing general support and guidance. Tremendous thanks to the staff at MIRINZ AgResearch for technical assistance with sampling and analysis. The statistical expertise of Dr. John Waller of AgResearch was greatly appreciated.

The project would not have been possible without the involvement of Greenlea Premier Meats. Their support of the project by providing access to the Morrinsville facility as well as the assistance of staff was tremendous!

This research was funded by the New Zealand Food Safety Authority Verification Agency. My thanks to Steve Gilbert, Director, and Chris Mawson, Deputy Director, Verification Agency, for their financial support of the project.

My loving thanks to my partner, Alec Jorgensen, who listened to my grumblings and threats to quit ... and just kept telling me to keep going. He always can see the forest while I'm lost in the trees.

This thesis is dedicated to my father whose sudden death two years ago made me pause to reflect on what is important in life. He would be proud of what I have achieved.

Table of Contents

| | |
|---|-----|
| Title page | i |
| Abstract | ii |
| Acknowledgements | iv |
| Table of contents | v |
| List of tables | vi |
| List of Figures | vii |
| Chapter 1: Introduction | 1 |
| Chapter 2: Review of Literature | 4 |
| Chapter 3: Materials and Methods | 27 |
| Chapter 4: Results & Discussion | 35 |
| Chapter 5: Conclusion & Recommendations | 44 |
| Appendix A | 48 |
| Appendix B | 49 |
| References | 50 |

List of Tables

| | |
|--|----|
| Table 1: Responses of target tissues to catecholamines..... | 7 |
| Table 2: Effects of epinephrine on muscle glycogenolysis..... | 11 |
| Table 3: Summary of muscle glycogen content..... | 16 |
| Table 4: Slaughter blood profile of bulls after mixing..... | 35 |
| Table 5: pH C of sampled striploin after mixing..... | 36 |
| Table 6: Shear force of sampled striploin after mixing..... | 36 |
| Table 7: Muscle glycogen of sampled striploin after mixing..... | 36 |
| Table 8: Colour measurements of sampled striploin after mixing..... | 37 |
| Table 9: Purge loss and drip loss of sampled striploin after mixing..... | 37 |
| Table 10: Correlation data..... | 38 |
| Table 11: Reported muscle glycogen concentrations from published literature..... | 43 |

List of Figures

| | |
|--|----|
| Figure 1: The HPA axis..... | 5 |
| Figure 2: Organization of skeletal muscle..... | 8 |
| Figure 3: Effects of epinephrine on muscle glycogenolysis..... | 12 |
| Figure 4A: The relationship between rank order and age..... | 22 |
| Figure 4B: The relationship between rank order and weight..... | 22 |
| Figure 5: The social interactions of young bulls and steers after re-grouping..... | 23 |
| Figure 6: The social interactions of young bulls and steers after re-grouping..... | 24 |
| Figure 7: Mixing protocol..... | 29 |
| Figure 8: Relationship between shear force and CPK..... | 39 |
| Figure 9: Relationship between muscle glycogen and CPK..... | 40 |
| Figure 10: Relationship between pH and CPK..... | 40 |

The effects of on-farm mixing of bulls on beef quality characteristics

CHAPTER 1 INTRODUCTION

The slaughter and processing of animals for meat and meat products has occurred since mankind's earliest history as a means of procuring necessary dietary protein. The process has dramatically changed during its evolution from a one man-one beast scenario to mass production driven by a need to feed enormous worldwide populations. Not only has the process changed but also the outcomes. The industrial age brought mechanization to the meat processing industry, made refrigeration possible and incorporated transport into the equation. These advances have changed the types of products that may be saved from an animal as well as the time that that product can be kept and the distances that the product can travel. This thesis does not attempt to define and document all the changes that have occurred during the birth and evolution of the meat industry. However, the historical perspective is introduced as it is relevant to desired outcomes that continually fail to be achieved despite knowledge gained.

Another aspect of animal slaughter has gained importance as society has developed. The animal welfare implications of animal production and slaughter have begun to receive considerable attention primarily in developed, "first world" countries. In developed countries, the meat consumer no longer finds himself in a position of hunter/gatherer. The challenges faced by early man in his attempt to keep himself and his family fed simply no longer exist for the average consumer. As man moves further and further from the actual procurement of his food, he has begun to question the moral issues of killing and consuming animals. As Emerson wrote, "You have just dined, and however scrupulously the slaughterhouse is concealed in the grateful distance of miles, there is complicity." In 2004 the World Animal Health Organization (OIE) stated that "animal welfare is a complex multi-faceted public policy issue that includes important scientific, ethical, economic and political dimensions. Because of its growing

importance in society, animal welfare must be addressed in a scientifically credible manner.” The following definition of animal welfare was adopted at the 76th OIE General Session (2008) ...

Animal welfare ... “means how an animal is coping with the conditions in which it lives. An animal is in a good state of welfare if (as indicated by scientific evidence) it is healthy, comfortable, well nourished, safe, able to express innate behaviour and is not suffering from unpleasant states such as pain, fear and distress. Good animal welfare requires disease prevention and veterinary treatment, appropriate shelter, management, nutrition, humane handling and humane slaughter/killing. Animal welfare refers to the state of the animal; the treatment that an animal received is covered by other terms such as animal care, animal husbandry, and humane treatment.”

Many countries have developed welfare guidelines and requirements with regards to how animals are reared and slaughtered. These requirements encompass all aspects of the industry including animal production, transportation to slaughter, pre-slaughter handling and humane slaughter.

New Zealand has had animal welfare laws since the 1870s. The current Animal Welfare Act 1999 is a departure from earlier legislation in that a welfare ethic has replaced a ‘prevention of cruelty’ ethic (O’Hara, 2008). The Animal Welfare Act 1999 includes a provision for codes of animal welfare. These codes are written by the National Animal Welfare Advisory Committee (NAWAC) in consultation with other advisors, scientists, experts and relevant industry groups. The codes contain minimum standards that are not enforceable in their own right; however, non-compliance may be used as evidence in a prosecution for a breach of the Act.

This thesis looks in particular at one aspect of production animal welfare; the mixing of bulls during pre-slaughter handling, and the implications for meat quality. As stated previously, failure to achieve a quality product occurs despite considerable scientific knowledge regarding best practice. Although much the same can be said for sheep, goats and deer, this thesis will focus on aspects related only to cattle, and more

specifically, bulls. The pre-slaughter period can have dire consequences on not only the welfare of the animal but also on the quality of the product that is produced from a stressed animal. An animal that is sufficiently stressed to produce poor quality meat must be considered both from an animal welfare perspective as well as an economic one. Economic losses will ensue from product that must be downgraded or has poor shelf life or display characteristics. Poor handling of an animal prior to slaughter may also result in bruising which must be trimmed off during processing. This trimming represents another economic loss to the supplier as well as the processor (Costa, 2009). While economic losses alone should encourage best practice in pre-slaughter handling, welfare issues are also relevant and increasingly important.

The primary objective of this research is to make an initial determination of whether on-farm mixing of bulls plays a role in undermining meat quality characteristics. The extent of that role will be examined. By varying mixing times it is also hoped that the effect of recovery from mixing on-farm can start to be elucidated. It is a further objective that demonstration of an effect on meat quality can be used to encourage industry to adopt certain handling practices that can be communicated to their suppliers. A best practice model of pre-slaughter handling on-farm would be the ultimate goal. This goal can only be reached through sound research that is then carefully communicated to industry decision-makers. This project represents only a starting point from which further research is likely to be needed prior to development of best practice guidelines.

CHAPTER 2

REVIEW OF LITERATURE

In order to have a complete understanding of the complex processes involved in an animal welfare failure that leads to a poor product, it is necessary to review numerous relevant topics. It is firstly essential to understand the biological components of stress and how the neuroendocrine system ultimately affects muscle physiology and in turn meat from muscle in the live animal. It is necessary to review the normal transformation of muscle tissue to meat as well as the variations that can occur when an animal is under a period of stress. In order to appreciate the importance of these biological changes to the current project, stresses associated with pre-slaughter handling are reviewed. This review includes a description of the establishment of social order or dominance hierarchy in cattle as this issue is of particular relevance to the research. Finally, the review considers the implications of social regrouping or “mixing” of animals during the pre-slaughter period.

THE BIOLOGY OF ANIMAL STRESS

A complete discussion of the complex responses of the body to an actual or perceived stress is beyond the scope of this thesis. General overviews of the neuroendocrine and sympathoadrenal responses to stress are presented as a background for a more detailed description of the metabolic consequences and the resulting effect on muscle.

The relationship between stress and related responses by the body was first described by Hans Selye in 1939 as the general adaptation syndrome (Selye, 1939). In general, Selye’s early work noted changes in the size of endocrine tissues as the result of exposure to stressors. The best known neuroendocrine system is the hypothalamic-pituitary-adrenal (HPA) axis. Activation of this system ultimately results in secretion of steroid hormones from the adrenal cortex (Hedge et al., 1987). Research conducted since Selye’s early work has confirmed the existence of corticotrophin-releasing hormone (CRH) and vasopressin (VP) that are secreted by the hypothalamus which is located in the brain (Greco & Stabenfeldt, 2002). Secretion is stimulated by the activation of the sympathetic division of the nervous system in response to a stressor

(Hedge et al., 1987). CRH and VP further stimulate the anterior lobe of the pituitary gland to release adrenocorticotropic hormone (ACTH) (Tanoue, 2009). Elevation of ACTH levels in the plasma stimulates the steroid-producing adrenocortical cells to synthesize and release glucocorticoids from the adrenal cortex (Greco & Stabenfeldt, 2002). Cortisol is the primary glucocorticoid in humans and most mammals (Greco & Stabenfeldt, 2002). This description of the HPA axis is an extremely simplified version of a complex interaction that remains to be completely understood. Recent research has demonstrated that an ‘all-or-none’ stress response is a gross oversimplification. The brain appears to be able to distinguish between stressors and respond accordingly in the types and levels of hormones that are secreted. For example, during haemorrhage, CRH, VP, oxytocin and catecholamines are all released while during hypotension only CRH is released (Plotsky et al., 1985a, b).

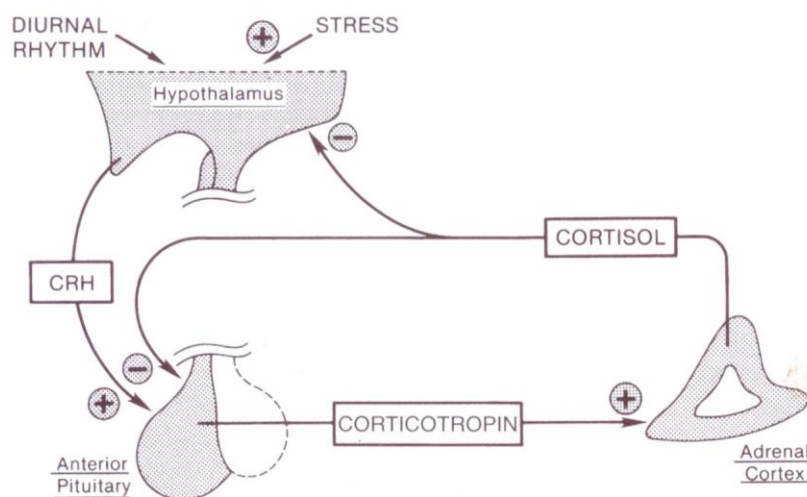

Figure 1
The HPA axis. Plus signs indicate stimulation; minus signs indicate inhibition. (From Hedge, G.A., Colby, H. D., Goodman, R. L. 1987. *Clinical Endocrine Physiology*. p. 143. W. B. Saunders, Philadelphia, USA.)

The sympathetic nervous system (SNS) is also activated by stress, and its actions comprise the “fight-or-flight” response (Cunningham, 2002). The SNS is a branch of the autonomic nervous system, and its neurons are considered part of the peripheral (versus central) nervous system (Cunningham, 2002). In response to stress, splanchnic sympathetic neurons cholinergically activate the release of catecholamines from

chromaffin cells in the adrenal medulla (Park et al., 2008). Binding of these catecholamines, e.g. epinephrine, to peripheral tissues results in the classic fight-or-flight responses which include, pupil dilation, increased heart rate, constriction of blood vessels (increased blood pressure), bronchial dilation, and elevated free fatty acid concentrations (Cunningham, 2002; Shaw & Tume, 1992). These responses prepare the body for action and, as the central nervous system is not involved, the responses occur without conscious thought (Cunningham, 2002). Table 1 shows the response of target tissues as a result of binding by catecholamines to a catecholamine receptor (α , β) .

Historically, the two regions of the adrenal gland, the cortex and the medulla, were considered to function as two independent endocrine systems. Recent evidence indicates that the “adrenal cortex and medulla appear to be interwoven and show multiple contact zones without separation by connective tissue or interstitial membranes” (Schinner & Bornstein, 2005). The two areas interact with each other through their hormones. Adrenal “crosstalk” results in cortisol acting on the adrenal medulla to synthesize catecholamines, most notably epinephrine (adrenaline), norepinephrine (noradrenaline) and dopamine (Schinner & Bornstein, 2005). Like the glucocorticoids, the catecholamines stimulate gluconeogenesis and play a role in maintaining homeostasis.

Table 1
Responses of Target Tissues to Catecholamines

| Target tissue | Receptor type | Response |
|------------------------|---------------|--|
| Liver | β_2 | Glycogenolysis, lipolysis, gluconeogenesis |
| Adipose tissue | β_2 | Lipolysis |
| Skeletal muscle | β_2 | Glycogenolysis |
| Pancreas | α_2 | Decreased insulin secretion |
| Cardiovascular system | β_2 | Increased insulin secretion |
| | β_1 | Increased heart rate, increased contractility, increased conduction velocity |
| | α_2 | Vasoconstriction |
| | β_2 | Vasodilation in skeletal muscle arterioles, coronary arteries, and all veins |
| | | |
| Bronchial muscle | β_2 | Relaxation |
| Gastrointestinal tract | β_2 | Decreased contractility |
| Urinary bladder | α_2 | Sphincter contraction |
| | β_2 | Detrusor relaxation |
| Uterus | α_2 | Contraction |
| | β_2 | Relaxation |
| Male sex organs | α_2 | Ejaculation, detumescence |
| | β_2 | Erection? |
| Eye | α_1 | Radial muscle contraction |
| | β_2 | Ciliary muscle relaxation |
| Central nervous system | α_2 | Stimulation |
| Skin | α_2 | Piloerection, sweat production |
| Renin secretion | β_1 | Stimulation |

From Hedge, G.A., Colby, H. D., Goodman, R. L. 1987 *Clinical Endocrine Physiology*. p.305. W. B. Saunders, Philadelphia.

Nwe et al. (1996) conducted an extensive study of changes in blood metabolites and hormone concentrations, including catecholamines, in goats being transported. Their study indicated that the response to this stress had two phases: a hypothalamic-adrenal cortex phase and a sympathetic-adrenal medulla phase. In their study, the initiation of transportation stress activated the sympathetic nervous system and then the adrenal medulla and cortex were simultaneously activated.

MUSCLE PHYSIOLOGY

In order to understand the effects of stress on muscle, and ultimately meat, it is necessary to have a general understanding of muscle physiology. Huddart in 1975 described the organization of skeletal muscle tissue as follows. All skeletal muscle is

composed of tightly packed bundles of muscle cells, also known as muscle fibres. Regardless of the fibre arrangement within muscles, each individual fibre has a similar ultrastructure. These multinucleated cells contain individual units known as myofibrils. The myofibrils are arranged in parallel bundles. The rod-like myofibril is divided into a series of identical repeated units which are responsible for the characteristic pattern of light and dark bands associated with skeletal or 'striated' muscle. The dark-staining Z discs are at each end of these individual units, and the distance from Z disc to Z disc is known as a sarcomere. The sarcomere is the basic contractile element of the muscle cell (Cunningham, 2002).

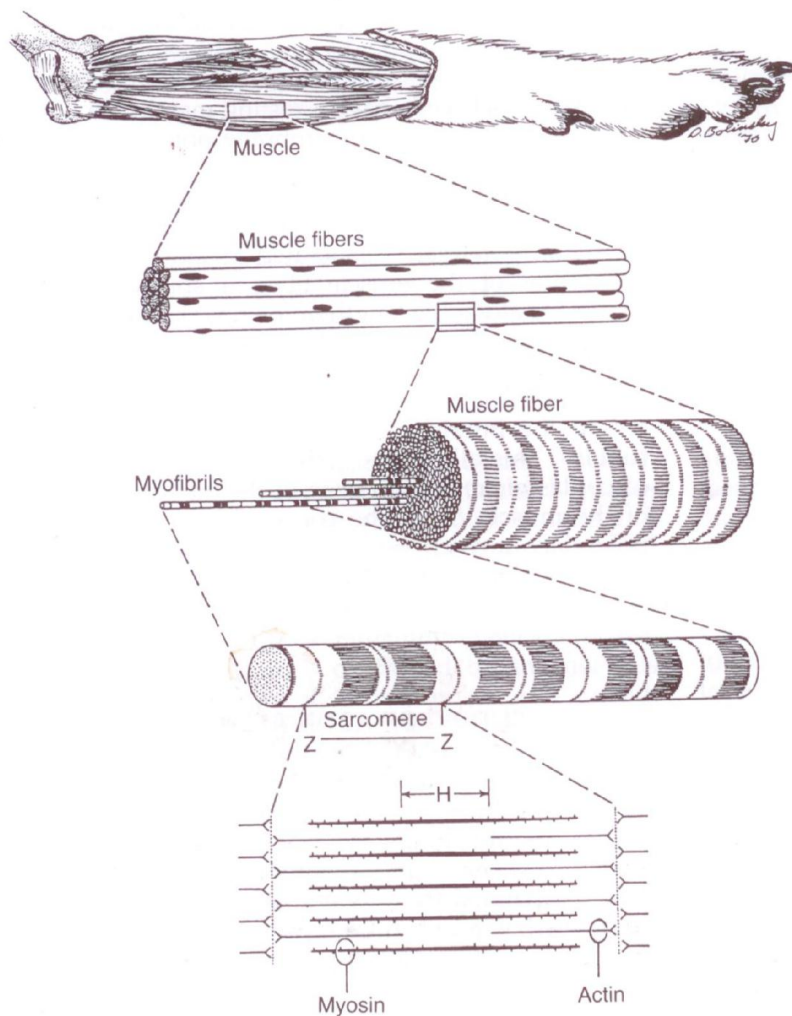

Figure 2
 Organization of typical skeletal muscle.
 (From Cunningham, J. G. (ed.) 2002. *Textbook of Veterinary Physiology*, 3rd edition. p. 46. W. B. Saunders Company, Philadelphia, USA.)

Within each sarcomere are two types of myofilaments which make up the majority of the contractile machinery of the sarcomere (Huddart, 1975). These myofilaments are primarily polymers of the proteins myosin and actin and are commonly known as 'thick' and 'thin' filaments respectively (Huddart, 1975). When viewed under electron microscopy, these thick and thin filaments can be seen to overlap in a regular, repeating pattern. This area of overlap is responsible for the ability of muscle to contract (Cunningham, 2002). Other structural proteins of the sarcomere that have been identified include tropomyosin, troponin and actinin (Hubbart, 1975).

During skeletal muscle contraction, the head regions of a myosin filament bind to the actin filament. Due to changes in the molecular structure of both of these proteins, a shortening occurs which pulls the filaments across each other. Collective bending of numerous myosin heads all in the same direction combine to move the actin filament relative to the myosin filament which results in muscle contraction (Heidemann, 2002).

Muscles are signalled to contract by motor neurons that release acetylcholine into neuromuscular junctions (Cunningham, 2002). The series of signals that are involved in transmitting this message to the individual contractile units are beyond the scope of this thesis; however, one element is important to understand. In order for myosin to release its binding site on actin, a molecule of adenosine triphosphate (ATP) must be available (Heidemann, 2002). ATP is the energy source for most cells in the body. ATP can be produced from glucose either aerobically or anaerobically. Engelking in 2004 described both of these pathways as follows. In the aerobic pathway, pyruvate which has been formed from glucose, is oxidized through the tricarboxylic acid (TCA) cycle to yield 15 ATP. The TCA cycle occurs inside cellular mitochondria. In the absence of oxygen, glucose can be converted to pyruvate and lactate which also releases a small number of ATP. Anaerobic glycolysis occurs in the cellular cytosol. The necessary glucose for these processes can be absorbed directly from the blood but is also stored in the liver and muscle. The storage form of glucose is glycogen (Engelking, 2004). The amount of glycogen in muscle varies not only from species to species but also within the animal from muscle to muscle. The glycogen content of muscle is normally around 1% by weight (Engelking, 2004). In the *longissimus* muscle of cattle the measured concentration of glycogen varies between 60 and 100 mmol/kg (1.08 – 1.80%) of tissue

(Immonen et al., 2000a). The importance of glycogen during the transition of skeletal muscle to meat will be demonstrated later in this review.

Muscle fibres differ in the primary mechanisms that they use to produce ATP, the type of motor neuron innervation, and their type of myosin heavy chain. Proportions of each type of fibre differ from muscle to muscle and from animal to animal (Pösö & Puolanne, 2005). Engelking in 2004 described the muscle fibre types as follows. Type I fibres (also referred to as “red” and “slow-twitch”) produce ATP primarily by aerobic metabolism. This method, also known as oxidative metabolism, requires oxygen and is relatively slow. Type I fibres are recruited for long-term aerobic activity and are resistant to fatigue. Type I fibres are also known as slow, oxidative (SO). Type II fibres (also referred to as “fast-twitch”) are divided into two types. Type IIa fibres can produce ATP by both anaerobic and aerobic mechanisms and are known as fast, oxidative, glycolytic (FOG). Type IIa fibres are utilised for long term (less than 30 minutes) anaerobic activity. Type IIb fibres (also referred to as “white”) are used for short term (less than 5 minutes) anaerobic activity, and produce ATP by anaerobic metabolism. These Type IIb fibres are known as fast, glycolytic (FG).

When an animal “exercises” it initially utilizes readily available ATP in muscle followed by ATP generated from anaerobic glycolysis. According to Engelking, 2004 another source of phosphates for production of ATP in muscle is creatine phosphate (CPO₃). Cytoplasmic creatine phosphokinase (CPK_c) catalyses the reaction that transfers a phosphate group from CPO₃ to ADP to form ATP.

STRESS EFFECTS ON MUSCLE PHYSIOLOGY

Both cortisol and the catecholamines exert an influence on muscle cells (Matteri et al., 2000). In response to stress the body prepares for action by increasing glucose levels in the bloodstream (Cunningham, 2002). One reservoir of glucose is provided by catabolism of glycogen stores in muscle tissue. Catabolism of glycogen is known as glycogenolysis (Engelking, 2004). Catecholamine stimulation of glycogenolysis occurs as a result of binding of the hormone to β-adrenergic receptors in muscle cells (Scheurink & Steffens, 1990). This pathway activates the enzyme glycogen phosphorylase which catalyses the breakdown of glycogen to glucose-1-phosphate units

(Engelking, 2004). An increase in epinephrine concentration has been demonstrated to augment contracting skeletal muscle glycogenolysis in both animals (Issekutz, 1984; Issekutz, 1985; Richter et al., 1982; Richter et al., 1981) and man (Febbraio et al., 1998; Greenhaff, 1991; Jansson et al., 1986; Spriet et al., 1988). Table 2 shows the effects of infusion of epinephrine on plasma lactate, glucose and free fatty acids in human subjects during 40 minutes of exercise. Muscle glycogen and muscle lactate concentration before and after exercise and with and without epinephrine infusion are shown in Figure 3. The data presented in Table 2 and Figure 3 indicate the effect of epinephrine on muscle glycogenolysis; an elevation in circulating epinephrine increases intramuscular glycogen utilization.

Table 2

Plasma lactate, glucose, free fatty acids, and norepinephrine concentrations during 40 min of exercise at 70% $\dot{V}O_{2peak}$ with or without epinephrine infusion

| | Rest | 10 Min | 20 Min | 30 Min | 40 Min |
|------------------------|-------------|-------------|-------------|--------------|--------------|
| Lactate, mmol/l | | | | | |
| Con | 1.0 ± 0.1 | 3.6 ± 0.5 | 3.5 ± 0.5 | 3.4 ± 0.5 | 3.2 ± 0.4 |
| Epi | 1.2 ± 0.1 | 4.9 ± 0.7 | 4.8 ± 0.7* | 4.2 ± 0.6 | 4.6 ± 0.7* |
| Glucose, mmol/l | | | | | |
| Con | 5.0 ± 0.2 | 5.1 ± 0.1 | 5.4 ± 0.1 | 5.5 ± 0.2 | 5.5 ± 0.2 |
| Epi | 4.9 ± 0.3 | 5.5 ± 0.2* | 5.9 ± 0.3 | 6.1 ± 0.5 | 6.2 ± 0.5 |
| FFA, mmol/l | | | | | |
| Con | 0.25 ± 0.03 | 0.24 ± 0.04 | 0.25 ± 0.01 | | 0.33 ± 0.04 |
| Epi | 0.19 ± 0.02 | 0.20 ± 0.04 | 0.26 ± 0.03 | | 0.28 ± 0.01 |
| Norepinephrine, nmol/l | | | | | |
| Con | 1.92 ± 0.31 | 7.18 ± 0.43 | 9.50 ± 1.00 | 11.31 ± 1.23 | 10.89 ± 1.42 |
| Epi | 1.24 ± 0.12 | 6.49 ± 0.43 | 8.19 ± 0.73 | 9.06 ± 0.57 | 9.19 ± 0.65 |

Values are means ± SE for 6 men. FFA, free fatty acids. *Difference compared with Con, $P < 0.05$.

From Febbraio, M. A., Lambert, D. L., Starkie, R. L., Proietto, J., & Hargreaves, M. (1998) Effect of epinephrine on muscle glycogenolysis during exercise in trained men. *Journal of Applied Physiology*, 84 (2), 468.

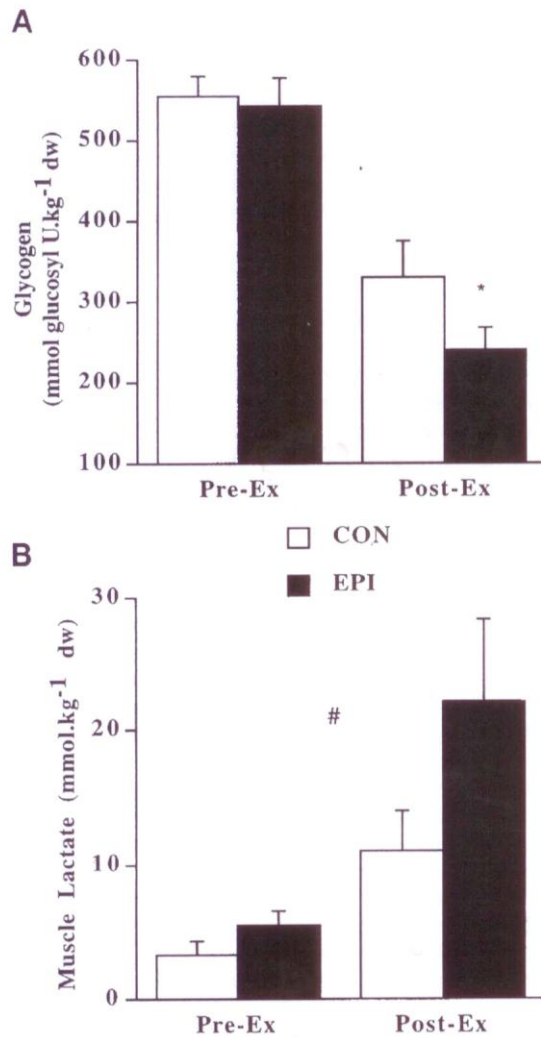

Pre-Ex – before exercise; Post-Ex – after 40 minutes of cycling exercise; EPI – epinephrine infusion; CON – without epinephrine infusion; dw – Dry weight Values are means \pm SE; n = 6 men; * - significant difference compared with CON, $P < 0.05$; # - main treatment effect, $P < 0.05$.

Figure 3

Muscle glycogen and muscle lactate concentration before and after exercise at 70% peak oxygen uptake with or without epinephrine infusion. (From Febbraio, M. A., Lambert, D. L., Starkie, R. L., Proietto, J., & Hargreaves, M. (1998) Effect of epinephrine on muscle glycogenolysis during exercise in trained men. *Journal of Applied Physiology*, 84 (2), 468)

With respect to cellular glycogen content, the muscle fibre types have been shown to respond differently depending on the type of stress imposed. Lacourt & Tarrant (1985) introduced two different forms of stress by either mixing unfamiliar bulls for 5 hours

(physical stress) or administering subcutaneous adrenaline (emotional stress). Mixing stress resulted in increased glycogen depletion from the two fast/glycolytic fibre types (FG & FOG) as compared to the slow oxidative fibres. Adrenaline caused a greater loss of glycogen from the slow fibres than from the two fast fibre types.

MUSCLE TO MEAT – THE ROLE OF MUSCLE GLYCOGEN

The basic principles of muscle physiology continue to apply after an animal has been slaughtered. It is these processes that result in the conversion of muscle to meat. After death the body attempts to continue to supply its systems with energy (ATP).

“Immediately post-mortem ATP is used in muscles for involuntary contractions and maintenance of membrane potential including sequestering of calcium within the sarcoplasmic reticulum” (Pösö & Puolanne, 2005). As available oxygen is rapidly exhausted, supply mechanisms switch from aerobic to anaerobic systems. Muscle glycogen is the main fuel of the anaerobic glycolysis that takes place after slaughter when muscles are no longer supplied with oxygen (Immonen & Puolanne, 2000). Production of ATP via the anaerobic pathway results in accumulation of lactic acid (Pösö & Puolanne, 2005). Lactate is the end product of anaerobic glycogen breakdown. Bendall (1979) showed that ATP content remained at the normal level (8-10 mmol/kg) until half of the ultimate amount of lactate is produced. ATP content then starts to decline. Once ATP concentration reaches 1 mmol/kg, the onset of rigor mortis will follow (Honikel et al., 1983). The post-mortem rate of pH fall is approximately 0.005 pH units per minute in beef and sheep (Pearson & Young, 1989); however, this rate is substantially affected by temperature of the muscle (Pösö & Puolanne, 2005).

Anaerobic glycolysis of bovine muscles ceases when the pH has reached 5.6 to 5.3 (Greaser, 1986; Howard & Lawrie, 1956), even in the presence of large amounts of residual glycogen (Bendall, 1973; Lawrie, 1955). A study by Immonen & Puolanne (2000) showed that meat of normal pH (≤ 5.75) had, on average, high residual carbohydrate and differed significantly ($p < 0.0001$) from meat of higher pH. However, the lower the pH the larger the range of residual carbohydrate concentrations (10 to 83 mmol/kg).

The anaerobic production of lactate post-mortem results in acidification of muscle tissue and is a prerequisite for turning muscles into high quality meat. Normal high quality

beef has an ultimate pH (pH_u) of between approximately 5.4 and 5.6 and a pre-slaughter muscle glycogen content of 1-1.5% (Ferguson et al., 2001). If pre-slaughter glycogen drops below 0.6% (6 mg/g), the resulting pH_u will be above 5.7 (Ferguson et al., 2001). Similarly, Tarrant (1988) reported that to achieve an ultimate pH of 5.5 in the post-slaughter muscle there needs to be at least 57 $\mu\text{mol/g}$ (1.03% of muscle weight) of glycogen in the muscle pre-slaughter to form sufficient lactic acid to lower pH. This calculation was based on the relationship between the meat ultimate pH value and muscle glycogen content at slaughter expressed by the formula $\text{pH}_u = 7.1 - 0.028g$ (McVeigh, 1980). In this equation, g is the glycogen concentration in beef longissimus dorsi muscle expressed in μmoles of glucose equivalents per gram of wet tissue. According to Immonen et al. (2000a) approximately 45 mmol of glycogen (0.81% of muscle weight) is needed to lower the pH of 1 kg of muscle from 7.2 to 5.5. Pethick et al. (1999) reported pre-slaughter muscle glycogen concentrations in the range from 60 to 120 $\mu\text{mol/g}$ (1.08 – 2.16% of muscle weight) for well fed cattle. Other studies have shown resting muscle glycogen concentrations of well-fed bovines to be 80 to 140 mmol/kg (1.44 – 2.52% of muscle weight) (Crouse et al., 1984; Immonen et al., 2000a, c,d; McVeigh & Tarrant, 1982; Pethick et al., 1994). Graafhuis and Devine (1994) measured ultimate pH of beef in a New Zealand-wide survey of abattoirs using a conventional pH probe. For beef (540 steers, 770 bulls) they found that approximately 80% of bulls had a pH above 5.7. Young et al. (2004) reported 62% of bulls at a single abattoir had pH_u above 5.7.

High pH meat is commercially known as 'dark-cutting' or DFD (dark, firm and dry). DFD meat has a dark colour, reduced shelf life, bland flavour and variable tenderness (Ferguson et al., 2001). Carcasses with pH_u values of 6.0 and above in the longissimus muscle are considered to be dark-cutting (Tarrant & Sherington, 1980). The dark, firm and dry appearance is caused by the muscle proteins remaining largely undenatured, because of the low acidity, and the pigment myoglobin remains in the deoxygenated form (Warriss, 1990). Deoxygenated myoglobin is purple rather than the bright-red of the oxygenated form. Consumers associate the dark colour with older, less-tender meat and will discriminate against it (Warriss, 1990). An ultimate pH greater than 5.75 starts to adversely affect tenderness and colour (Purchas et al., 1999) and shelf life (Newton & Gill, 1980). Up to a pH of 6.0, dark cutting meat is tougher (Purchas & Aungsupakorn, 1993). Egan & Shay (1988) reported that vacuum-packaged beef of pH 6.2-6.5 will

spoil within about 6 weeks at 0 ° C, with the rate of spoilage increasing as muscle pH increases. In comparison, vacuum-packaged normal pH meat (5.4-5.8) had a storage life of 10-12 weeks at 0 ° C.

Clearly, any event prior to slaughter that significantly depletes glycogen will have a deleterious effect on meat quality. Stress during the pre-slaughter period can result in the release of cortisol and catecholamines (Tarrant & Grandin, 1993). As summarized earlier, these 'stress hormones' serve to increase glycogenolysis, and as a result, the body's reserves of glycogen can be depleted. Ante mortem glycogen breakdown can also be triggered by strenuous muscle activity such as mounting and is the most closely associated behaviour with glycogen depletion and dark-cutting in beef (Tarrant & Grandin, 1993). This behaviour is stimulated by social regrouping as in mixed penning of young bulls (McVeigh & Tarrant, 1983; Warriss et al., 1984). Mounting associated with oestrus in groups of females can have a similar effect (Kenny & Tarrant, 1988). Without adequate rest and feed this animal may be slaughtered while in a glycogen deficit. "Glycogen reserves at slaughter are a function of the initial levels of glycogen and the losses due to stresses placed on the animal during the immediate pre-slaughter period" (Thompson, 2002). Table 3 summarizes the results of previous research that has looked at the effect of various treatments and conditions on muscle glycogen concentration.

Replenishment of glycogen is of significant importance in ruminants due to their unique carbohydrate metabolism (Tarrant, 1988). The nature of the rumen means that access to glucose is not directly available. Rather glucose must be made from proprionate which can then be converted to glycogen (Lister, 1988). This process results in a delay in replenishing glycogen stores. McVeigh et al. (1979) reported that the recovery of glycogen to resting concentration required 7 days. In fermentative digestion, molecular substrates are broken down by enzymes that are microbial in origin versus glandular digestion where these enzymes are produced by the body (Herdt, 2002). In general, fermentative digestion is much slower than glandular digestion (Herdt, 2002). Microbial enzymatic action liberates glucose which is then absorbed into the cell bodies of the microbes (Herdt, 2002). Ultimately, due to anaerobic conditions, glycolytic pathways lead to the production of volatile fatty acids (VFAs) that are essentially bacterial waste products. The primary VFAs are acetic acid, propanoic acid and butyric

acid (Herdt, 2002). The VFAs are absorbed by the host animal, subjected to aerobic metabolism and produce energy for the host (Herdt, 2002).

Table 3

A summary of muscle glycogen content, especially in regard to bovine longissimus muscle, as a result of various treatments and conditions.

| Reference | Type animal | No. of animals | Treatment imposed | Method of measuring glycogen | Results | Conclusions |
|-------------------------|----------------|------------------------------|---|---|--|--|
| Howard & Lawrie, 1957 | steers | 2 treated; 2 controls | Forcibly exercised for 1.5 hrs after transport by rail. They were not fed while on the train. Controls were fed for 14 days prior to slaughter after arrival at the abattoir. Treated group were not fed. | Extraction and double precipitation procedure* in conjunction with colorimetric sugar estimation** (four different muscles sampled) | Statistically significant ($P < 0.001$) decrease of glycogen in both muscle and liver for treated vs. controls and general increase of pH _μ for treated. | Results confirmed that enforced exercise produced significant effects when applied after prolonged travel. |
| Howard & Lawrie, 1957 | steers | 2 treated; 2 controls | Fasted for 14 days after transport and then forcibly exercised for 1.5 hrs. | Extraction and double precipitation procedure* in conjunction with colorimetric sugar estimation** | Significant increase ($P=0.05$) in mean ultimate pH _μ . Differences in muscle glycogen not significant. | Glycogen reserves for treated were still sufficiently high to bring about the pH _μ normal for well-fed animals. |
| Tarrant & McVeigh, 1979 | bulls | 6 | Ten muscle biopsies taken from each animal over a 24 hour period. | Samples taken from longissimus muscle. Hydrolysed by using amyloglucosidase from <i>Aspergillus niger</i> and determined as free glucose by using glucose oxidase and peroxidase | Mean overall value was 96.7 μmol/g (± 1.79 ; $n = 60$) | Procedure used for sampling did not cause unacceptable degree of stress in cattle. |
| McVeigh et al., 1979 | bulls | 12; 6 treated and 6 controls | Mixed for 6 hours with an established herd of 10 bulls. | Samples taken from longissimus muscle. Glycogen determined as per Tarrant & McVeigh, 1979. Samples taken at termination of stress and during recovery period. | Muscle glycogen content fell to 41% of the value for the control animals ($P < 0.001$). Day 1 of recovery – 45% of control values. Day 2 of recovery – 70% of control values. Significant difference ($P < 0.01$) until Day 7 of recovery. | Slow rate of glycogen repletion unexpected and unexplained. |
| Lister & Spencer, 1983 | sheep | 27 | Infusion of catecholamines with simultaneous blockade of lipolysis. | Samples taken from longissimus muscle. Muscle dissolved in KOH. Glycogen precipitated by addition of ethanol. Precipitate hydrolysed in HCL. Glucose in resulting solution measured using glucose oxidase method. | Concentrations greater than 5 mg/g glycogen in muscle at death allowed an ultimate pH of 6.0 or less to be attained. | Suggested that dark cutting is due to balance of α - β -stimulation resulting from handling and the consequent availability and utilisation of local and peripheral energy stores |
| Immonen et al., 2000d | bulls & steers | 19 & 19 | 2x2 factorial design. Factors were male status and dietary energy density. | Samples taken from longissimus muscle. Muscle was homogenized and then hydrolyzed in HCL. Glucose determined via NADP reduction. | High energy diet superior for increasing muscle glycogen content for both bulls and steers when initial glycogen content depleted. In repleted state, | Neither diet nor male status are major determinants of resting muscle glycogen concentration. |

| | | | | | | |
|-------------------------|---------|-------------------------|---|--|---|---|
| | | | | | glycogen concentration not affected by energy density. | |
| Immonen et al., 2000c | bulls | 60 | Bulls fed either a high energy (HE) diet or a low energy (LE) diet for a short time prior to transportation to slaughter. Identical set up of 30 bulls run in both spring and summer. | Samples taken from gluteus medius and longissimus muscle. Muscle was homogenized and then hydrolyzed in HCl. Glucose determined spectrophotometrically. | Losses of glycogen during transportation (mmol/kg): HE spring - 7 ± 4.0 HE summer - 23 ± 3.9 LE spring - 16 ± 3.8 LE summer - 33 ± 4.1 | High energy diet seemed to protect cattle from potentially glycogen – depleting stressors. Recommended providing a high energy diet for a couple of weeks prior to slaughter to protect against dark-cutting. |
| Kenny & Tarrant, 1988 | heifers | 24 (3 groups of 8 each) | Oestrus versus control (non-oestrus or mid-cycle) | Samples taken from longissimus muscle. Determined as glucose after hydrolysis with amyloglucosidase and α -amylase. | Oestrus associated with loss of glycogen in M. longissimus dorsi ($P < 0.001$). Oestrus versus control yielded 39% versus zero dark-cutting carcasses ($P < 0.05$). | Recommended single penning of oestrus heifers to eliminate mounting activity and reduce incidence of dark-cutting. |
| Lacourt & Tarrant, 1985 | bulls | 16 | Stress induced by either 5 hours of mixing or injection with adrenaline. | Samples taken from longissimus muscle. Determined as glucose after hydrolysis with amyloglucosidase and α -amylase. Examined differences among the three muscle fibre types for glycogen content. | Muscle glycogen declined to 45% of resting value after 5 h of stress ($P < 0.001$) and 37% after adrenaline treatment ($P < 0.001$). During mixing stress glycogen loss from the two fast-twitch fibre types was more rapid and extensive. Glycogen loss was greater in the slow-twitch fibres after adrenaline administration. | Glycogen selectively depleted in muscle fibres in response to stress. Depletion pattern varies according to the type of stressor. Muscles high in glycolytic/fast-twitch fibres may be prone to dark-cutting when stress is predominantly physical in nature (mixing). Muscles high in oxidative/slow-twitch fibres more prone to dark-cutting from emotional stress (adrenaline-mediated). |
| Crouse et al., 1984 | bulls | 12 | Biopsy at 11 days pre-fasting, at the end of fasting (96 hours) and at 3, 7, 10 & 14 days post-fasting. | Samples taken from longissimus muscle. Determined as glucose after homogenizing and hydrolysis with HCl and amyloglucosidase. | Fasting for 96 h reduced muscle glycogen from 77 to 50 $\mu\text{mol/g}$ by day 0. Depressed glycogen levels persisted through day 3. Repletion rate of 3 $\mu\text{mol/g}$ from day 3 to 7. | Recommended management systems designed to prevent muscle glycogen depletion prior to slaughter given low muscle glycogen repletion rates. |
| McVeigh et al., 1982 | bulls | 12 | Mixed for 6 hours with an established herd of 10 bulls. | Samples taken from longissimus muscle. Glycogen determined as per Tarrant & McVeigh, 1979 but with the addition of α -amylase in the hydrolyzing medium. | At the end of the stress period, glycogen content of the longissimus muscle was 41% of the value of the controls ($P < 0.001$). Increased to 70% (day 2), 75% (day 4), 90% (day 7) and 105% (day 10). Glycogen repletion rate of 6.6 $\mu\text{mol/g/d}$. | Suggested that slow glycogen recovery rates may be characteristic of ruminants due to inherently lower blood glucose concentration and insulin activity. |
| Tarrant & Lacourt, 1984 | bulls | 14 | S = mixed for 5 hours with an established herd of | Samples taken from longissimus muscle. Glycogen determined as | S – glycogen fell to 57% of baseline value after 3 h of | Pre-stress hyperglycaemia as induced by |

| | | | | | | |
|----------------------|--------|--------------------------------------|---|--|--|---|
| | | | 10 bulls; T = subcutaneous injection of dexamethasone pre-stress; insulin and glucose administered post-stress Groups: S, TS & T | per McVeigh et al., 1982. | mixing and 49% after 5 h. TS – glycogen fell to 55% after 3 h of mixing and 43% after 5 h. T – no effect on glycogen | dexamethasone administration did not alter the net rate or extent of muscle glycogen breakdown or recovery. |
| Warriss et al., 1984 | bulls | 28 | Mixed with unfamiliar animals overnight and then slaughtered at 0, 1, 2, 4, 7, 9 or 10 days | Samples taken from longissimus and psoas muscles and frozen in liquid nitrogen. Analysis for glycogen as per Sugden et al., 1976. Precipitated glycogen hydrolysed then glucose measured spectrophotometrically. | All animals killed immediately after mixing had pH _u > 6 in the longissimus. By day 2 of recovery all animals had pH _u < 6. Concentrations of muscle glycogen in the longissimus had recovered by day 4. | Young bulls from separate rearing groups mixed before slaughter require resting with food for at least 48 hours before being killed to ensure that no carcasses have high pH _u . |
| Sanz et al., 1996 | bulls | 48 (24 each of two different breeds) | Animals divided into a stress group (S) and a control group (C). Stressed animals were mixed with unfamiliar animals overnight. | Samples taken from the longissimus and the sternomandibularis muscles. Muscle glycogen determined by an enzymatic method (Bermeyer & Bernt, 1974). | In group S, pH _u was between 5.17 and 7.07. In group C, pH _u was between 5.35 and 5.60. All animals in group S showed lower glycogen concentrations than the animals in group C. | Concluded that the main cause of dark cutting was due to physical and emotional stress of mixing unfamiliar animals overnight. No breed effect seen. |
| Lambert et al., 1998 | steers | 48 (Trial 1) 31 (Trial 2) | Trial 1: Animals assigned to 1 of 3 groups. Control, short exercise or long exercise. Short exercise consisted of walking 4km/hr over a 2.5 km course. Long exercise was twice around the short exercise course. Trail 2: control group and exercise group. Exercise was more strenuous than Trial 1. | Biopsy of the longissimus muscle. Glycogen concentration as per Dreiling et al., 1987. | Exercise did not affect glycogen concentration in either trial. | Walking mature, well-fed steers at a moderate speed for 40 minutes is not likely to significantly deplete muscle glycogen content. |
| Lahucky et al., 1998 | bulls | 43 | Divided into 30 control animals and 13 stressed. Stress was created by mixing overnight at the abattoir. | Biopsy of the semitendinosus muscle ante mortem. Sample of the longissimus muscle post mortem. Glycogen concentrations as per Dreiling et al., 1987. | Ante mortem and post mortem (1 hr., 3 hr.) muscle glycogen concentrations were depleted (p < 0.01) in all stressed bulls. | Ante mortem and early post mortem glycogen levels could be a good predictor for the dark cutting condition. |
| Lambert et al., 2000 | steers | 45 | Animals divided into 3 groups of 15. Treatments were control (C), yarded for 24 hours (Y) and yarded and transported (YT). YT groups yarded for 20 hours and transported for 4 hours. Control group grazed pasture adjacent to the yards. Y and | Samples taken from the longissimus muscle by biopsy. Muscle glycogen determined as per Dreiling et al., 1987. | Muscle glycogen level was not influenced by Y or YT treatment. | Concluded that had animals been slaughtered, the treatments would have had little influence on pH _u . Two potential pre-slaughter stressors (yarding/fasting and short-haul transport) do not affect muscle glycogen concentration of well-fed steers. |

| | | | | | | |
|-------------|-------|----|---|--|---|--|
| | | | YT groups had only water available. | | | |
| Onenc, 2010 | bulls | 20 | Treated group ($n = 10$) offered electrolyte-glucose drink while in lairage for 18 h. Control group had access to water only. | Samples taken from longissimus muscle. Glycogen determined as per Immonen et al., 2000c. | Muscle glycogen content significantly higher ($P < 0.01$) in treated group (11.6 mmol/L) compared with controls (8.8 mmol/L). | Electrolyte-glucose treatment in lairage caused a significant improvement in carcass and meat quality. |

*Good, Kramer & Somogyi, 1933

**Kemp & van Heijningen, 1954

In general, the results of the studies summarized in Table 3 indicate that pre-slaughter stress results in a decrease in muscle glycogen concentrations. The stresses imposed in these studies were considerably different in that some were physical (e.g. forced exercise) and some emotional (e.g. oestrus) while others could be considered both (e.g. transport, mixing). In some studies stress was simulated by infusion of catecholamines. Results indicate variation in recovery of muscle glycogen stores after a stressor; however, there is consensus that slaughter prior to 24 hours after a stress results in a decreased muscle glycogen content. The studies do not agree on the absolute glycogen concentration needed to produce normal pH meat; however, methods for measuring glycogen were different.

PRE-SLAUGHTER HANDLING

In 'The Biology of Animal Stress', Moberg & Mench (2000) defined stress as "the biological response elicited when an individual perceives a threat to its homeostasis." The threat is the 'stressor'. When the stress truly threatens the animal's well-being, then the animal experiences 'distress'. Like humans, animals can experience routine 'stress' that does not compromise their animal welfare (Costa, 2009). However, in certain situations that stress may escalate to 'distress'. For example, on a hot day, heat may be perceived by the animal as a stressor. The animal moves to shade to escape the stress. If the animal is unable to move from the heat due to its physical state, restraint, or a lack of shade, stress may cause distress. Clearly an animal that can escape the heat is not a concern from an animal welfare perspective. Numerous similar situations will occur during the animal's life, but it is only those that cause distress that result in a poor animal welfare situation (Amadori et al., 2009). According to McEwen (2002), stress

can be harmful when it is long lasting and the animal is unable to successfully cope with it.

Animals can be stressed by either psychological events such as restraint, handling or novel events as well as physical events such as the above example of heat (Costa, 2009). Other physical stresses include hunger, thirst and fatigue. An animal responds to a novel event with fear. This fear response is fundamental to the “flight” reaction. Fear motivates animals to avoid predators. According to Grandin (1993), for animals in the wild, a novel or strange sight or sound can often be a sign of danger. Even tame animals can have an extreme flight reaction when suddenly confronted with novelty that is perceived as a threat (Grandin, 1997). Ranchers and horse trainers have reported that ordinarily calm animals will become agitated and difficult to handle when confronted with the novelty of a livestock show or auction (Grandin, 1997). Spensley et al. (1995) reported increased heart rate and motor activity in piglets exposed to novel noises for 20 minutes.

Prior to the period immediately preceding slaughter the majority of grass-fed cattle have generally limited experiences. Many will have only been on one property, and they will have had few human interactions and perhaps only limited interactions with other species such as dogs. The majority of these animals will not have experienced transport except perhaps as very young calves. The animals will have established a dominance hierarchy within their grazing groups that are generally well maintained.

Clearly, during the yarding and transport to a meat processing plant these animals will encounter numerous novel situations. Upon arrival at a processing plant, in addition to the numerous differences of the lairage facility, the animals may be mixed with unfamiliar stock, subjected to washing and hosing, encounter novel surfaces such as concrete or gratings, and be subjected to new and/or loud noises and unfamiliar sights and smells.

ESTABLISHMENT OF SOCIAL ORGANIZATION IN CATTLE

Cattle in herds will naturally interact and develop relationships that are of a dominant-subordinate nature. The outcomes of these interactions will ultimately result in the

establishment of a social order or dominance hierarchy (Hafez & Bouissou, 1975). The concept of “pecking order” was first introduced by Schjelderup-Ebbe in 1922 (as cited in Beilharz & Zeeb, 1982). “Pecking order” or dominance hierarchy is established through interactions between any two individuals in a group. In each of these interactions there is a “winner” and a “loser”. As the outcome of each pairing is determined, the overall order is established. Initial establishment of order will inevitably involve aggressive behaviours such as fighting. Once a social structure is established within a stable group, aggression and fighting tend to decrease (Beilharz & Zeeb, 1982). Additionally, development of cohesiveness within a group can diminish fear responses by a process known as social buffering (Boissy & Le Neindre, 1990). Mounier et al. (2006) mixed bulls at the beginning of fattening. When compared to unmixed peers, the mixed bulls were less ready to eat next to each other, displayed more fear-related responses during social separation and were more stressed during pre-slaughter handling.

Schein and Fohrman (1955) described social dominance relationships in herds of dairy cattle. According to their observations, “aggressive” interactions included a sequence of events which included an *approach*, which could be active or passive, a *threat*, and potentially, *physical contact*. An *active approach* indicated purposeful behaviour rather than two animals inadvertently crossing paths within a pasture. In the *threat* phase, one of the two animals involved in the interaction lowers its head to halfway between the normal position and the ground with its forehead perpendicular to the ground and directs its eyes towards the other animal. The authors postulated that this position served to direct the horns (regardless of whether or not the animal had horns) towards its opponent. The threatened animal may either respond in kind or retreat. Direct *physical contact* includes *butting* and *fighting*. Each “contest” results in a winner and a loser. Based on observations and recording of outcomes of individual contests, Schein and Fohrman were able to describe a straight-line peck-order or rank order. Their results indicated a highly significant positive relationship between rank order and age and rank order and weight as illustrated in Figures 4A and 4B.

4A

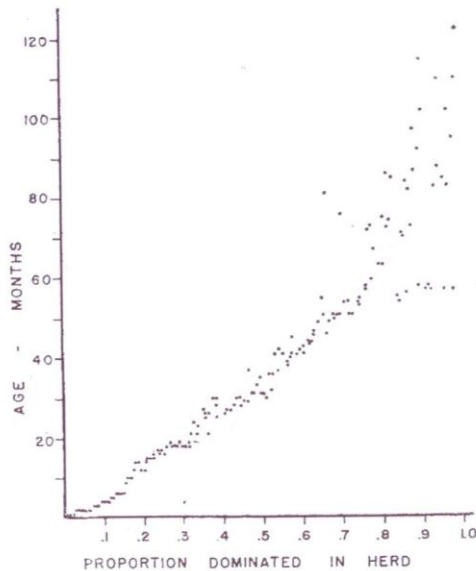

4B

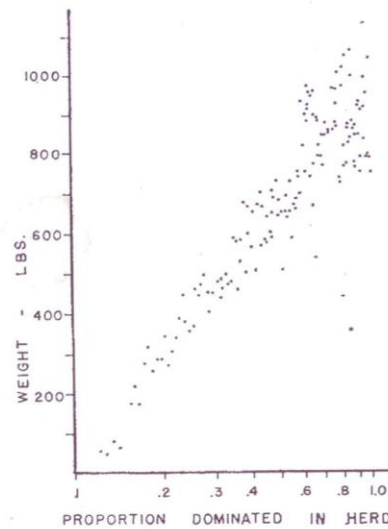

Figure 4A

The relationship between rank order and age. Rank order refers to straight-line peck-order where the most dominant (alpha) animal wins contests from all others down to the omega animal who loses to all others.

Figure 4B

The relationship between rank order and weight. Rank order refers to straight-line peck-order where the most dominant (alpha) animal wins contests from all others down to the omega animal who loses to all others.

(From Schein, M. W. & Fohrman, M. H. (1955). Social dominance relationships in a herd of dairy cattle. *British Journal of Animal Behaviour*, 3, 51.)

Partida et al. (2007) observed four groups of Friesian bulls to determine Social Dominance Indexes (SDI) as described by Lehner (1996). Direct observation was used to record agonistic interactions between pairs of bulls. For each interaction, the type of interaction (action or reaction) is identified as well as the outcome (winner or loser). SDI is calculated as G/T , where G = number of winner interactions, and T = the total number of interactions. SDI values were used to rank individuals from least dominant (0) to most dominant (1). All bulls were then assigned to either the low, medium or high dominance class based on their score. The authors observed that agonistic interactions were more common between animals with similar social rank (up to three rank positions apart) than between animals widely separated by SDI. Average daily growth rates were significantly ($p \leq 0.05$) higher in the medium and high SDI groups. At slaughter there was no difference between social dominance status with respect to

meat quality characteristics. It should be noted that these animals were not regrouped prior to slaughter, and the time between transport and slaughter was one hour and 30 minutes. The authors hypothesized that instability in the social hierarchy may have masked the effects of social status on the variables studied. Because the groups were homogeneous with respect to age, weight and body size, frequent changes in rank may have occurred.

Tennessen et al. (1985) studied the social interactions of young bulls and steers after regrouping. In both bulls and steers, regrouping resulted in high rates of overt aggressive behaviour. This behaviour was much higher in bulls than steers, but in both groups the frequency decreased quickly. By 10 days post-mixing, both bulls and steers showed very little aggressive behaviour (Figure 5). Mounting and other “sexual” behaviour showed a similar pattern to aggressive behaviour with high levels immediately after mixing followed by a decline in activity (Figure 6).

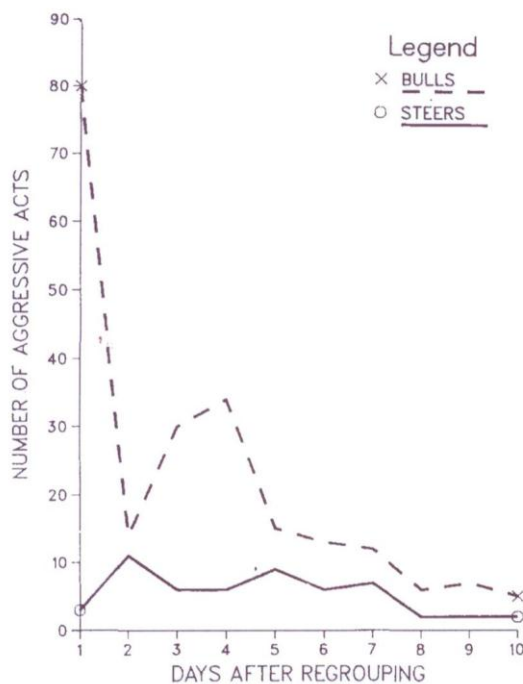

Figure 5
The mean hourly occurrence of aggressive acts (headbunts+bunts+threats) among bulls and steers for 10 days following re-grouping; July (age circa 15 months). Data collected between 09.00 and 21.00 h. (From Tennessen, T., Price, M. A. & Berg, R. T. (1985) The social interactions of young bulls and steers after re-grouping. *Applied Animal Behaviour Science*, 14, 42.)

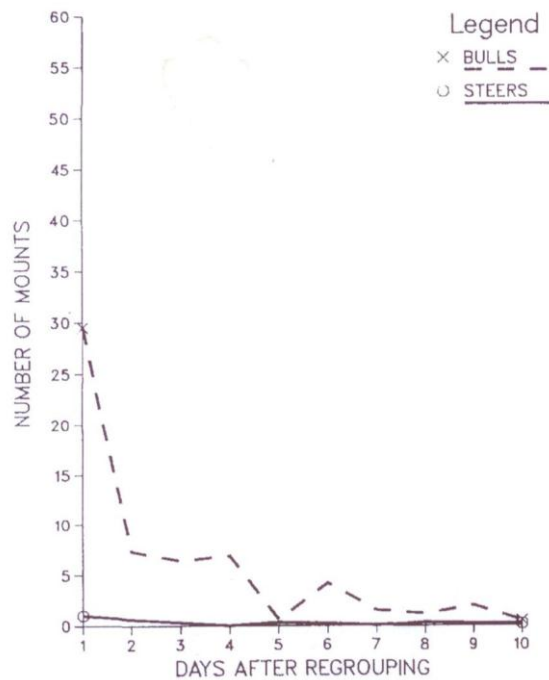

Figure 6
 The mean hourly occurrence of mounting among bulls and steers for 10 days following re-grouping; July (age circa 15 months). Data collected between 09.00 and 21.00 h. (From Tennessen, T., Price, M. A. & Berg, R. T. (1985) The social interactions of young bulls and steers after re-grouping. *Applied Animal Behaviour Science*, 14, 43.)

Establishment of a social order has been found to occur in animals as young as 250 days of age (Stricklin et al., 1980). The authors found evidence that dominance orders were formed soon after weaning. These orders were maintained when the groups were moved to other pens. As found by Schein & Fohrman (1955), weight was positively correlated with dominance position.

STRESS AS THE RESULT OF SOCIAL REGROUPING DURING THE PRE-SLAUGHTER PERIOD

One of the most stressful experiences during the pre-slaughter period appears to be mixing of unfamiliar animals especially in confined spaces such as abattoir lairage pens. Numerous research studies have confirmed the negative effects of social regrouping prior to slaughter of all classes of cattle (Grandin, 1979; McVeigh, 1980; Puolanne & Aalto, 1980; Price & Tennessen, 1981; McVeigh et al., 1982; McVeigh & Tarrant, 1983; Warriss et al., 1984; Lacourt & Tarrant, 1985; Tennessen et al., 1985; Kenny & Tarrant, 1987; Warriss, 1990; Mohan-Raj et al., 1992; Sanz et al., 1996). These effects can be potentially disastrous when combined with additional pre-slaughter stressors

such as transport, fasting, and exposure to novel situations (Bray et al., 1989). According to Warriss (1990), “dark cutting beef is the extreme example of the influence of pre-slaughter stress on meat quality in cattle.”

The major cause of dark, firm and dry beef (DFD), particularly in young bulls, is mixing unfamiliar animals (Warriss, 1990). Pre-slaughter handling practices that encourage mixing therefore increase the incidence of DFD. Mixing bulls results in agonistic behaviour due to their desire to re-establish their dominance hierarchy. These agonistic behaviours include butting, pushing, mounting and fighting. Mounting has been observed to be the most common behaviour during social regrouping, followed by mock fighting and chin resting (Kenny & Tarrant, 1987). This physical stress coupled with the emotional stress of the situation depletes muscle glycogen. The importance of the physical stress in muscle glycogen depletion was demonstrated by Kenny & Tarrant (1987). Mounting was shown to be the most important behaviour in depleting glycogen in the longissimus muscle. Use of an overhead electrified wire grid in abattoir pens prevented mounting behaviour in regrouped bulls in lairage. This intervention reduced the incidence of DFD to zero. This result was replicated by Bartos et al. (1988); however, zero incidence of DFD only occurred when combining two treatments - an overhead electrified grid and darkness.

Prolonged exercise, as occurs with mounting and fighting bulls, requires a significant supply of energy. This energy can be provided by oxidation of fatty acids and glucose. However, should these blood-borne metabolites not provide sufficient supply, muscle glycogen will be mobilised. Mixing stress in cattle results in elevated levels of creatine phosphokinase (CPK), non-esterified free fatty acids (NEFA), β -hydroxybutyrate (BHB), lactate dehydrogenase (LDH), glutamate-oxaloacetate-transaminase (GOT) and cortisol and decreased plasma lactate (Warriss et al., 1984). It is known that epinephrine and norepinephrine raise blood NEFA concentrations (Tsuda, 1994). Sanz et al. (1996) confirmed that the physical and emotional stress of mixing unfamiliar bulls overnight was the main cause of glycogen depletion and the occurrence of the dark cutting condition. Lahucky et al. (1998) compared ante and post mortem muscle glycogen concentrations in control versus stressed bulls. These glycogen values were then compared to selected meat quality traits. Ante and post mortem (1 hour and 3

hours) muscle glycogen was depleted in all stressed bulls ($p < 0.01$). Ultimate pH in the stressed bulls was 6.70 ± 0.24 compared to 5.66 ± 0.23 in the control bulls.

Significant research into best practice regarding pre-slaughter handling has resulted in various recommendations to the meat industry (Thompson, 2002; Tatum et al., 1999). These recommendations take into consideration the stress response of the animal and the effect of that stress on the final product. Most researchers advocate the careful handling of animals from the time they leave the farm until they are slaughtered. Mixing of unfamiliar stock, especially young bulls, is known to be detrimental to meat quality not only within research circles but also by meat processing company employees and decision-makers. One area that has not been well researched and perhaps not even realised by industry is the potential for mixing of unfamiliar stock at the farm prior to transport. In preliminary investigations for this project, it was found that it is not uncommon for a supplier to mix his stock in holding pens prior to pick up by the transport operator. The time of mixing can vary from several hours to overnight. These mixed groups comprise animals from various finishing mobs that have reached market weight. Other animals from these mobs that have not reached target market weight are returned to their original paddock for a further period on feed. Thus, mixed groups of bulls will arrive at the abattoir and will be held for a further period of time in this mixed state. The processing company will consider these animals as an “unmixed” mob based on their origination from the same farm. The dark cutting condition may result despite their best intentions of careful pre-slaughter handling. Due to the potential impact on meat quality, the Meat Standards Australia (MSA) beef quality assurance scheme includes a prohibition on regrouping cattle from different groups or pens on a property within two weeks of transport to slaughter (Anon., 2002). Colditz et al. (2007) designed a project to test the relevance of this specification. Physiological and meat quality variables were measured from steers that were regrouped at a feedlot 4, 2 or 1 week prior to slaughter. While there was no difference in physiological variables, meat from steers regrouped 1 week before feedlot exit had significantly higher compression values than meat from controls. The authors recommended that cattle not be regrouped within 2 weeks of slaughter.

While numerous studies have examined the potential to elevate muscle glycogen concentration in feedlot cattle based on various high energy diets, the predominance of a

pastoral production system in New Zealand makes these recommendations irrelevant. A sudden change to a diet of high-energy concentrate can result in rumenal acidosis (Knee et al., 2007). Additionally, cattle from a totally grass-fed background must be trained to eat supplements (Knee, et al., 2007). This training is necessary to ensure that cattle eat as much as they are offered from the start of the feeding programme. Without training, cattle may take weeks to become accustomed to trough feeding and their new diet (Knee et al., 2007).

Consideration of the MSA recommendations prohibiting regrouping of cattle within two weeks of transport to slaughter while also considering the New Zealand pastoral production system would seem to indicate a significant gap in knowledge that should be addressed. This project is designed to determine if on-farm mixing of bulls in a pasture fed system has a detrimental affect on meat quality factors.

CHAPTER 3

MATERIALS AND METHODS

Thirty-three Friesian bulls between 18 and 24 months of age and weighing between 550 and 600 kilograms (live weight) were commercially slaughtered in January of 2010. These animals were reared on the same farm from weaning until transport to slaughter. The animals were fed solely pasture during the final six months leading up to slaughter. During their lifetime the animals were primarily fed on pasture with the addition of silage/haylage during times of pasture shortage. Ethical permission for this project was issued by the AgResearch Ruakura Animal Ethics Committee on November 20, 2008.

The bulls were maintained on the farm in finishing groups that ranged from 3 to 17 animals. The animals had been maintained in these groups for a minimum of 6 months prior to the mixing required as part of the current investigation. Four days prior to slaughter each of seven finishing groups (Groups A, B, C, D, E, F & G) were separately brought into the yards for final weighing (Figure 7). Groups A & B were randomly chosen as control groups. The animals were weighed, marked with tail paint and their ear tag numbers recorded. They were then returned to their original paddock. From

Group A all 3 of 3 animals were sent to slaughter. From Group B, 3 of 12 animals were sent to slaughter. These 3 animals remained with their entire group until loading. From the remaining five groups, animals were randomly chosen to be assigned to a 4-day mixed group. For example, 2 bulls from Group C and 2 bulls from Group D were mixed to create Group CD₄. The remainder of the bulls in Groups C & D remained with their cohorts. The same procedure was followed for Groups D & E (DE₄) and Groups F & G (FG₄). This process resulted in three 4-day mixed groups. One day prior to slaughter the same procedure was followed to create “one-day mixed” groups (CD₁ & EF₁). The result was seven separate groups – two unmixed groups/controls (A & B); three four-day mixed groups (CD₄, DE₄, FG₄) and two one-day mixed groups (CD₁ & EF₁).

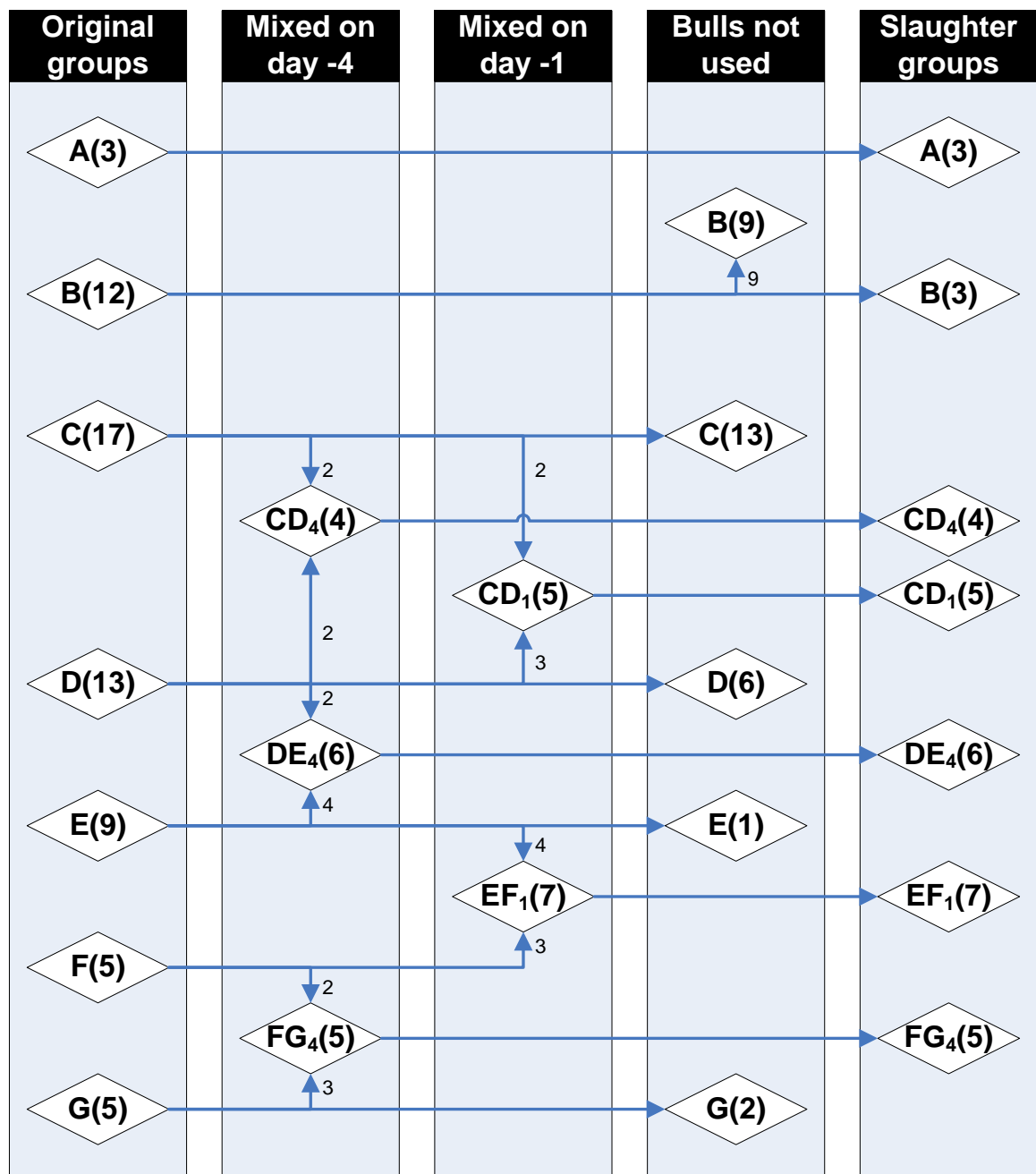

Figure 7

Mixing protocol. A flow diagram showing the number of bulls in the various original groups as well as those in the mixed and non-mixed slaughter groups. The number in brackets in each case is the number of bulls. In terms of pre-slaughter treatments, there were 6 bulls in the unmixed groups (A & B), 12 in the groups mixed 1 day prior to slaughter (day -1; CD & EF), and 15 in the group mixed 4 days prior to slaughter (day -4; CD, DE & FG).

On the morning of slaughter all the bulls were transported at the same time and on the same truck. Each group was brought individually into the yards from their home paddock and loaded immediately. In the case of Group B, the three control animals had to be drafted out of the total mob of 12. For all other groups the entire mob was sent for slaughter, so no drafting was required. Bulls were transported with their respective

groups in different pens. The largest two groups of six and seven bulls had to be split in order to fit into a pen. (Maximum number of bulls per pen that could be accommodated was five.) The distance from the farm to the abattoir was 57 kilometres, and the total travel time was less than one hour. Care was taken to ensure no mixing occurred in lairage at the processing facility. The animals were slaughtered at a commercial export meat processing facility, Greenlea Premier Meats, Morrinsville, New Zealand, in accordance with New Zealand and relevant overseas market access regulatory requirements. Slaughter began approximately 30 minutes after the last bull was unloaded and was completed within approximately two hours of arriving at the facility. Due to halal requirements the bulls were stunned using head-only reversible electrical stunning. Stunning parameters are 2.5-3.5 amps for 2.5-3.5 seconds. Following the opening halal cut, the bull was electrically immobilised for 30 seconds. The immobiliser operates as a stepped wave form for 1 millisecond at 65 millisecond intervals and 330 volts. During this time further bleeding was achieved through severance of the brachiocephalic trunk.

At the time of slaughter, blood samples were collected at sticking into small plastic jars. The blood was then gently drawn into 20 ml syringes without needles to avoid haemolysis and then quickly transferred to one 10 ml plain vacutainer (for serum) and one 5 ml 2% fluoride oxalate vacutainer (for plasma). As samples were collected they were held in a refrigerator at 4°C. At completion of the experiment all samples were transported in a chilly bin to a commercial diagnostic pathology laboratory for analysis using laboratory established protocols. The samples reached the laboratory within 1 hour of the last animal being slaughtered. The blood samples were immediately centrifuged at ambient temperature for 5 minutes at 3,000 rpm (1940g) in a Heraeus Multifuge 3S+. Analysis for non-esterified fatty acids (NEFA mmol/L), plasma lactate (mmol/L), creatine phosphokinase (CPK IU/L) and haemolytic index were run on a Hitachi Modular P800 module. Analysis kits for CPK and lactate were supplied by Roche Diagnostics NZ. A NEFA analysis kit was supplied by WAKO, Japan via MedBio NZ. The analysis kits utilize an in vitro enzymatic colorimetric method for quantitative determination of L-lactate in plasma and NEFA or CPK in serum. Haemolytic index was calculated based on the absorbance measurement of haemoglobin that provides a semi-quantitative representation of the level of haemolysis in the sample. The method is as described by Roche Diagnostics. A high haemolytic index would

have indicated mishandling of a sample during blood collection and resulted in erroneous values of measured variables. Two samples had moderate haemolysis while all others had either zero to mild haemolysis. Of the two samples with moderate haemolysis, all results were in the normal range.

As the processing facility utilizes hot boning of carcasses, muscles samples were collected on the day of slaughter. The sample was taken approximately 20 minutes after slaughter. Approximately 200 mm of longissimus muscle (i.e. striploin) was collected from each animal and tagged with its carcass number. The sample was taken starting at the quarter cut (12th rib) from the caudal end of the muscle. A sub sample was immediately snap frozen and stored in liquid nitrogen for later glycogen analyses. Once all samples were collected they were transported to the meat science laboratory at MIRINZ AgResearch Ruakura and held at 10°C until the pH was below 6.0 then chilled to 4°C. This change occurred at approximately five hours post mortem.

At twenty-four hours post slaughter, the longissimus muscle samples were divided into three portions (“A”, “B” & “C”) by transverse cuts. Each portion was 30 to 40 mm in length. “B” and “C” samples were vacuum-packed in barrier bags and stored at -1.5°C for a further 7 and 28 days, respectively.

All samples were tested for:

- 1) pH at 24 hours post slaughter (pH A) and after 7 (pH B) and 28 days (pH C) of storage
- 2) Shear force at 24 hours post slaughter and after 7 and 28 days of storage
- 3) Meat colour analysis on bloomed and unbloomed “A” samples
- 4) Drip loss at 24 hours post slaughter and after 7 & 28 days of storage
- 5) Purge loss due to storage for samples “B” and “C”
- 6) Muscle glycogen concentration on the “at slaughter” snap frozen sample.

pH measurement

pH was measured by spear insertion at 24 hours post slaughter and again after 7 and 28 days of storage at -1.5 °C. pH was determined as the average of three replicate measures. pH measurements were taken using a calibrated Metler™ pH meter with an

automatic temperature compensation probe. The pH meter was a 'Testo 230' with an NTC food penetration temperature probe with measurement range of -25 to +150 °C (part number 06132411). The pH meter was calibrated using a 2 point calibration at pH 7.00 and 4.01 and operated under auto-temperature compensation protocols.

Shear force

Shear force was measured at 24 hours post slaughter and after 7 and 28 days of storage at -1.5 °C using the MIRINZ tenderometer™ and AgResearch MIRINZ protocol. Meat samples of minimum 30 mm thickness and weighing between 300 to 400 grams were prepared. Samples were weighed prior to cooking in a 99 °C water bath until an internal temperature of 75 °C was reached as determined by a continuous logging thermometer. The sample was then quickly cooled in an ice slurry until below 10 °C, patted dry and re-weighed. Meat was cut along the muscle fibre into 10 mm x 10 mm x 30 mm sections. Shear force measurements using the MIRINZ tenderometer (model #3) were then taken perpendicular to the fibre direction which was at right angles to the long axis.

Colour analysis

Colour measurements were taken on bloomed and unbloomed samples using a Hunterlab colourmeter™. Blooming was defined as a period of 2 hours at a holding temperature of -1 to 0 °C while covered with an oxygen permeable wrap (standard cling film). Colour was determined by measurements on longissimus cross-sections at three random spots. The colour values L (lightness), a (redness) and b (yellowness) were expressed as means of the three measurements (Honikel, 1998).

Drip loss

Drip loss was measured after 24 hours, 7 days or 28 days of aging according to the Honikel bag method (Honikel, 1998). A cube of longissimus muscle was prepared so that two of the surfaces of the cube were perpendicular to the grain of the meat. Cube weights were a minimum of 30 grams up to a maximum of 150 grams. The sample was weighed, the weight recorded, and placed in a single layer of onion bag netting that was twisted closed at the top and suspended inside a sealable, water impermeable container with hooks in the lids. Care was taken to ensure that the sample did not make contact with the side of the container. The sample was then placed in a 4 °C chiller for 48

hours. After 48 hours the sample was removed from the container, blotted dry and reweighed. Drip loss was expressed as a percentage of the initial weight.

Purge loss

The raw sample used for shear force measurements was weighed and vacuum-packed then held at -1.5°C until the appropriate storage time was reached. The sample was then removed from the plastic bag, gently blotted dry with a paper towel and reweighed. Purge loss was expressed as a percentage of the initial weight. The sample was then cooked and used for shear force measurements.

Muscle glycogen concentration

Muscle glycogen concentration from the snap frozen sample (frozen using liquid nitrogen) was determined using the perchloric extraction method (Krisman, 1961; Dreiling et al., 1987). The LL sample was homogenized in 0.6 M perchloric acid followed by centrifugation. An aliquot of the supernatant was treated with iodine reagent and the resulting colour measured spectrophotometrically. The concentration of the sample (in mg) was calculated from the sample absorbance using linear regression.

$$\frac{mg(glycogen)}{g} = \frac{mg(glycogen)}{wg(g)} \times \frac{dilution}{aliquot}$$

Statistical Analyses

The data were analysed using the ANOVA directive of GenStat (11th Edition). There was no evidence of a herd group effect for any variable measured, so the analysis was based on individual animals. The CPK data were log_e transformed. The back-transformed means quoted include bias correction and are obtained from: $\exp \{x + \frac{1}{2}s^2\}$ where s^2 is the residual variance from the ANOVA (Neyman & Scott, 1960). For the NEFA data there was a ‘mob’ effect after treatments were accounted for. For all other variables there was no ‘mob’ effect, and so ‘mobs’ were excluded from the analysis. Evaluation of the statistical significance of differences amongst treatments were carried out using a LSD (least significant difference) provided the overall F test was significant ($p < 0.05$). A repeated measures analysis was carried out for pH, drip loss and shear force, but this did not enhance the understanding of the experimental results. A summary of the repeated measures analysis is included as Appendix A. Appendix B

summarizes the time effects with respect to aging for pH, drip loss and shear force and for colour variables with respect to the time effect of fresh or bloomed.

CHAPTER 4

RESULTS & DISCUSSION

The mean slaughter blood profile of the bulls is shown in Table 4. The CPK data were log_e transformed to satisfy the assumptions of the analysis of variance (normal distribution with a common variance). CPK was elevated in the 1-day mixed group ($p < 0.001$). NEFA and lactate values were not significantly different among the three groups.

Table 4
Slaughter blood profile of bulls after mixing together with average slaughter and carcass weights. (CPK and NEFA measured in blood serum; lactate measured in blood plasma; see Figure 7 for animal group numbers.)

| | 1 day mixed | 4 day mixed | Control | p value | LSD (5%) |
|-----------------------|--------------------|--------------------|--------------------|---------|----------|
| No.of animals | 12 | 15 | 6 | | |
| Live weight (kg) † | 582 | 571 | 565 | | |
| Carcass weight (kg) † | 298.6 | 295.1 | 292.8 | | |
| NEFA ‡ (mmol/l) | 0.302 ^a | 0.187 ^a | 0.142 ^a | 0.275 | 0.2574 |
| CPK*‡ (IU/l) | 2145 ^a | 545 ^b | 351 ^b | 0.001 | 2.31** |
| Lactate ‡ (mmol/l) | 2.41 ^a | 2.13 ^a | 1.92 ^a | 0.711 | 1.228 |

‡ values listed are least squares means; * back- transformed means; ** least significant ratio (LSR) (5%); † average weight. Means within a row with different superscript letters show the treatments as significantly different ($p < 0.05$) using the LSD (5%) or LSR (5%). This was only applied where the overall test of differences amongst treatments was significant.

Meat quality measurements are summarized in Tables 5 to 9. The most significant findings were for shear force at 28 days ($p < 0.05$) and for meat yellowness (b) following blooming ($p < 0.05$). Some other variables were significant at $p < 0.10$.

Table 5

Least-squares means for ultimate pH* of sampled striploin for the three groups after 24 h, 7 d , and 28 d.

| | 1 day mixed | 4 day mixed | Control | p value | LSD (5%) |
|-----------------|--------------------|--------------------|--------------------|---------|----------|
| pH 24 hours (A) | 5.687 ^a | 5.567 ^a | 5.495 ^a | 0.053 | 0.1612 |
| pH 7 days (B) | 5.678 ^a | 5.612 ^a | 5.527 ^a | 0.188 | 0.1610 |
| pH 28 days (C) | 5.731 ^a | 5.655 ^a | 5.562 ^a | 0.09 | 0.1478 |

* values listed are least squares means; different letters show the treatments as significantly different ($p < 0.05$) using the LSD (5%) or LSR (5%). This was only applied where the overall test of differences amongst treatments was significant.

Table 6

Shear force* of sampled striploin after mixing

| | 1 day mixed | 4 day mixed | Control | p value | LSD (5%) |
|-------------------------|--------------------|--------------------|--------------------|---------|----------|
| Shear force 24 hr., kg | 18.98 ^a | 16.12 ^a | 15.44 ^a | 0.092 | 3.707 |
| Shear force 7 days, kg | 11.17 ^a | 9.81 ^a | 9.26 ^a | 0.315 | 2.757 |
| Shear force 28 days, kg | 8.7 ^a | 6.42 ^{ab} | 5.57 ^b | 0.022 | 2.401 |

* values listed are least squares means; different letters show the treatments as significantly different ($p < 0.05$) using the LSD (5%) or LSR (5%). This is only applied where the overall test of differences amongst treatments is significant.

Table 7

Muscle glycogen* of sampled striploin after mixing

| | 1 day mixed | 4 day mixed | Control | p value | LSD (5%) |
|------------------------|-------------------|-------------------|-------------------|---------|----------|
| Muscle glycogen (mg/g) | 2.61 ^a | 4.36 ^a | 4.77 ^a | 0.073 | 2.152 |

* values listed are least squares means; different letters show the treatments as significantly different ($p < 0.05$) using the LSD (5%) or LSR (5%). This is only applied where the overall test of differences amongst treatments is significant.

Table 8

Colour measurements* of fresh and bloomed sampled striploin after mixing Blooming was defined as a period of 2 hours at a holding temperature of -1 to 0 °C while covered with an oxygen permeable wrap (standard cling film).

| | 1 day mixed | 4 day mixed | Control | p value | LSD (5%) |
|-------------|--------------------|--------------------|--------------------|---------|----------|
| Fresh_L | 30.49 ^a | 32.18 ^a | 32.07 ^a | 0.083 | 1.948 |
| Fresh_a | 8.67 ^a | 8.83 ^a | 9.53 ^a | 0.062 | 0.698 |
| Fresh_b | 5.18 ^a | 5.38 ^a | 6.02 ^a | 0.096 | 0.743 |
| Fresh_hue | 30.72 ^a | 31.21 ^a | 32.28 ^a | 0.37 | 2.156 |
| Fresh_sat | 10.11 ^a | 10.35 ^a | 11.27 ^a | 0.062 | 0.945 |
| Bloomed_L | 32.40 ^a | 32.31 ^a | 33.98 ^a | 0.521 | 3.079 |
| Bloomed_a | 9.32 ^a | 10.20 ^a | 10.28 ^a | 0.088 | 1.070 |
| Bloomed_b | 5.91 ^b | 6.59 ^{ab} | 6.96 ^a | 0.046 | 0.870 |
| Bloomed_hue | 32.24 ^a | 32.79 ^a | 34.09 ^a | 0.141 | 1.786 |
| Bloomed_sat | 11.04 ^a | 12.14 ^a | 12.41 ^a | 0.064 | 1.332 |

* values listed are least squares means; L = lightness; a = redness; b = yellowness; different superscripted letters show the treatments as significantly different ($p < 0.05$) using the LSD (5%) or LSR (5%). This was only applied where the overall test of differences amongst treatments was significant.

Table 9

Purge loss and drip loss*[†] of sampled striploin after mixing

| | 1 day mixed | 4 day mixed | Control | p value | LSD (5%) |
|---------------------|--------------------|--------------------|--------------------|---------|----------|
| %Drip loss 24 hours | 1.15 ^a | 1.33 ^a | 1.47 ^a | 0.678 | 0.751 |
| %Drip loss 7 days | 1.65 ^a | 1.40 ^a | 1.65 ^a | 0.560 | 0.659 |
| %Drip loss 28 days | 1.95 ^a | 1.99 ^a | 1.91 ^a | 0.962 | 0.630 |
| %Purge loss 7 days | 2.081 ^a | 2.066 ^a | 2.526 ^a | 0.213 | 0.5497 |
| %Purge loss 28 days | 3.06 ^a | 2.89 ^a | 3.22 ^a | 0.724 | 0.860 |

[†] values listed are least squares means; *purge loss and drip loss are expressed as a percentage of the initial weight. Drip loss measurements were commenced after a period of aging of 24 hours, 7 days or 28 days respectively. Different letters show the treatments as significantly different ($p < 0.05$) using the LSD (5%) or LSR (5%). This is only applied where the overall test of differences amongst treatments is significant.

Table 10
Correlation data

| | <i>Lactate</i> | <i>log(CPK)</i> | <i>pH C</i> | <i>muscle glycogen</i> | <i>Shear force 28 days</i> |
|------------------------|----------------|-----------------------|-----------------------|------------------------|----------------------------|
| Lactate | 1 | | | | |
| Log _e (CPK) | -0.088 | 1 | | | |
| pH C | -0.154 | 0.686 ^{***} | 1 | | |
| muscle glycogen | 0.049 | -0.604 ^{***} | -0.737 ^{***} | 1 | |
| Shear force 28 days | 0.012 | 0.568 ^{***} | 0.570 ^{***} | -0.463 ^{**} | 1 |

** p < 0.01; *** p < 0.001

In the present study, the elevation in the concentration of creatine phosphokinase (logCPK) in serum at slaughter for the 1 day mixed group was highly significant ($p < 0.001$) when comparing the three treatment groups (Table 4). This finding is in agreement with Warriss et al. (1984) and McVeigh et al. (1982) with regards to elevated CPK in stressed animals; however, the decreased plasma lactate (Warriss et al., 1984) and elevated NEFA levels (Warriss et al., 1984; McVeigh et al., 1982) were not replicated in the current experiment. CPK is an enzyme in muscle that catalyses the conversion of ADP to ATP with the phosphate group coming from creatine phosphate, and the presence of elevated CPK in serum indicates strenuous or unaccustomed muscular exercise (Berg & Haralambie, 1978). Circulating creatine kinase is often monitored in transported cattle as a measure of bruising (Tarrant, 1990). The finding of elevated CPK in the 1 day mixed bulls would indicate that these animals were more physically active in the 24 hour period prior to slaughter than the 4 day mixed or control animals. Mean CPK values for the 4 day mixed group were not significantly different from the control animals. This information would seem to indicate that by four days, the bulls had re-established a social order and physical activity had returned to a normal level. McVeigh et al. (1982) found serum NEFA concentration increased immediately after a six hour stress period to almost twice the level of the controls. Eighteen hours after the end of the stress period NEFA concentration had returned to resting values. In this study blood was not collected from the 1 day mixed bulls until approximately 28 hours after the introduction of the stress. Therefore, it is possible that elevated NEFA levels were not detected.

In terms of meat quality, the difference in CPK values is relevant when considering that shear force measurements for the 1 day mixed bulls were also significantly higher ($p < 0.05$). At 28 days post slaughter, muscle tissue from the 1 day mixed bulls had increased shear force measurements when compared to the four day mixed and controls (Table 6). CPK values and shear force data were found to be positively correlated in the present study ($r = 0.568$; $p < 0.001$). CPK values were also positively correlated with pH C ($r = 0.686$; $p < 0.001$) and negatively correlated with muscle glycogen concentration ($r = -0.604$; $p < 0.001$) (Table 10). Graphs of regression for these relationships are illustrated in Figures 8, 9 and 10.

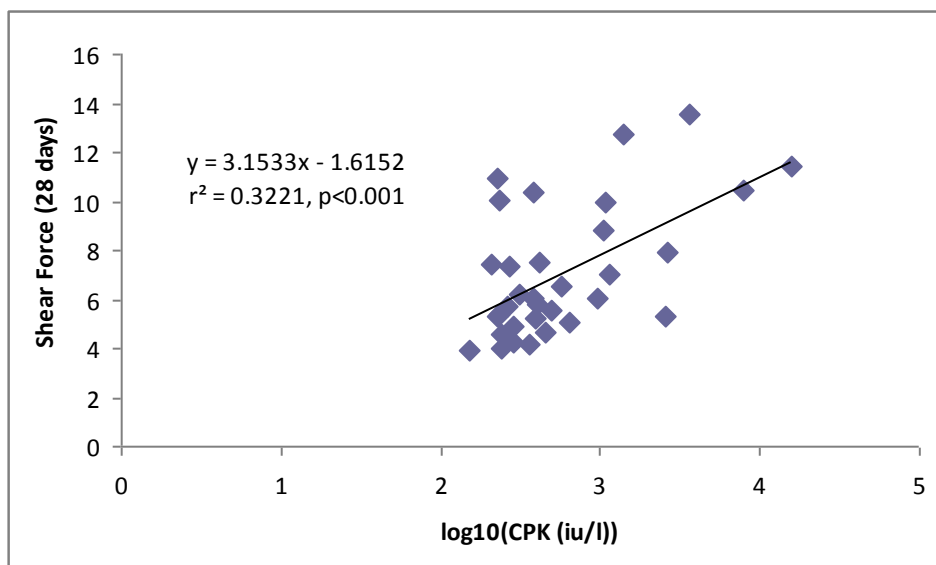

Figure 8. Regression analysis demonstrating the relationship between shear force at 28 days ageing and serum CPK

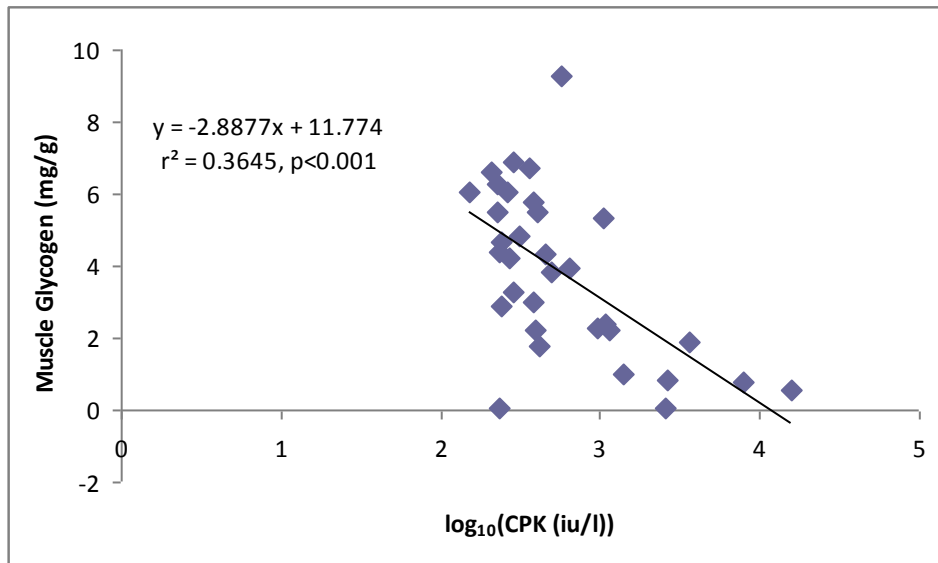

Figure 9. Regression analysis demonstrating the relationship between muscle glycogen in the longissimus muscle and serum CPK.

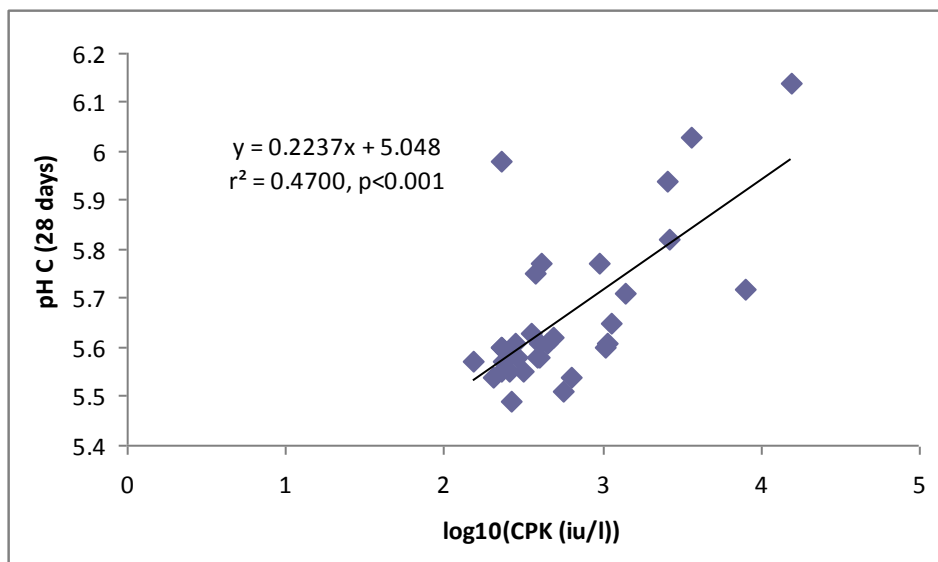

Figure 10. Regression analysis demonstrating the relationship between pH C (pH after 28 days ageing) and serum CPK.

Although not statistically significant ($p = 0.09$), the pH at 28 days (pH C) for the meat from the 1 day mixed animals was also increased when compared to the other two treatment groups. Five animals had a pH greater than 5.8 at 28 days. Three of the five were from the one day mixed group while the other two were from the four day mixed group. The highest pH C was 6.14, and this one day mixed animal also had the highest CPK at 15,756 IU/l. Not surprisingly muscle glycogen concentration from the 1 day mixed animals was lower than for the other two groups, and the significance followed the same trend ($p = 0.073$). A review of colour measurements, purge loss and drip loss

from Tables 8 and 9 indicates a similar pattern for these variables, but the results were not significant. pH C was negatively correlated with muscle glycogen concentration ($r = -0.737$; $p < 0.001$).

Although not significant, the relationship of pH to tenderness followed the trend reported by Purchas and Aungsupakorn (1993). At all three time points the pH for the control animals was lower than either the 1 day mixed group or the four day mixed group. The tenderness measurements mirrored this result. The highest mean pH was for the 1 day mixed group at 28 days, and this group also had the greatest force score at the corresponding time point.

Colour measurements also seemed to be following previously reported trends. Purchas et al., 1999 reported that higher ultimate pH values were associated with lower values for colour parameters (L, a & b). With only two exceptions (fresh L, bloomed L), the control animals with the lowest pH at 24 hours had the highest colour values. The one day mixed animals had the highest pH values at 24 hours and had correspondingly lower values for the measured colour parameters. Hue and saturation measurements followed an identical trend.

The results for purge loss and drip loss are difficult to interpret as the results were not significant, and there is no clear trend. However, drip loss at 24 hours when compared to pH at 24 hours would seem to follow the expected relationship as reported by Purchas et al. (1999). Higher pH_u values are associated with higher water-holding capacity. Muscle tissue from 1 day mixed bulls with mean pH_u of 5.687 had a drip loss of 1.15% as compared to the control bulls with a drip loss of 1.47% and a 24 hour pH of 5.495.

The muscle glycogen concentrations for the bulls in this study appear low when compared to those reported in the literature. Table 11 illustrates the variation of reported muscle glycogen concentration. According to Immonen et al. (2000c), reported resting muscle glycogen concentrations vary from 10.8 to 23.4 mg/g (60 to 130 mmol/kg) depending on different types of diets and rearing conditions. As a biopsy sample was not taken for this study it is impossible to predict resting muscle glycogen concentrations for these animals. Glycogen concentrations for all the bulls in the study

may have been affected by not only the imposed treatment but also the unavoidable physical and emotional stresses of handling and transport. It is also important to consider that the bulls in the current study were only pasture-fed. Based on the season and weather conditions at the time of the experiment (New Zealand summer with moderate drought conditions) it can be assumed that the diet was very low energy. Joyce et al. (1975) described 'ill-thrift' among cattle and sheep in New Zealand due to inadequacy of summer pasture. Concentration of blood glucose, the precursor of muscle glycogen, has been reported to decline in grass-fed cattle during late summer and autumn (Manston et al., 1977). Tarrant and Sherington (1980), suggested that some grass-fed cattle may have inadequate intake of energy at this time of the year and this may have a negative effect on muscle glycogen synthesis. A high energy diet has been shown to protect cattle from potentially glycogen-depleting stressors (Immonen et al., 2000c). Additionally, the seasonal effects of temperature and humidity may have contributed to the low glycogen concentrations. According to Grandin (1989), when cattle are transported in hot and humid conditions the incidence of dark-cutters increases.

Although the post-mortem glycogen concentrations were lower than others published, the correlation between glycogen level and pH is similar to that found by Lahucky et al. (1998). Their mean glycogen concentration at one hour post mortem for stressed animals was 4.05 mg/g which was negatively correlated with pH ($r = -0.73$, $p < 0.01$). However, the mean pH at 48 hours for their stressed bulls was 6.70 while all pHs in the present study were normal ($pH < 6.0$).

Sanz et al. (1996) reported similar trends to those found in the present study; however, muscle glycogen concentrations were higher. For example, Brown Swiss and Pirenaico bulls in the control group had mean muscle glycogen concentrations in the longissimus muscle of 14.68 and 13.90 mg/g respectively. Stressed Brown Swiss bulls with mean muscle glycogen of 2.67 mg/g were dark cutters with $pH \geq 6.00$. Although no "dark cutters" resulted from the current study, mean muscle glycogen for the 1 day mixed bulls was 2.61 mg/g compared with a mean of 4.77 mg/g for the controls ($p < 0.073$).

Table 11
Reported muscle glycogen concentrations from published literature.

| Reference | Species | No. animals | Muscle(s) sampled | Muscle glycogen concentrations reported (range) (mg/g) |
|-------------------------|---------|-------------|---|---|
| Lambert et al., 1998 | bovine | 79 | longissimus | 16.2 – 19.5 |
| Webby et al., 1999 | bovine | 967 | longissimus | 23.6 – 25.8 |
| Lambert et al., 2000 | bovine | 45 | longissimus | 17.3 – 19.1 |
| Warriss et al., 1984 | bovine | 28 | longissimus psoas | 2.7 – 12.6 2.8 – 7.8 |
| Sanz et al., 1996 | bovine | 48 | longissimus sternomandibularis | 2.7 – 14.7 2.5 – 8.7 |
| Howard & Lawrie, 1957 | bovine | 4 | longissimus psoas semitendinosus semimembranosus | 3.0 – 11.8 2.8 – 10.8 2.8 – 10.6 3.5 – 12.8 |
| Tarrant & McVeigh, 1979 | bovine | 6 | longissimus | 17.4* |
| Lahucky et al., 1998 | bovine | 43 | semitendinosus longissimus | 6.0 – 10.9 3.0 – 10.1 |
| Lister & Spencer, 1983 | ovine | 27 | longissimus | 2.7 – 10.4 |
| Immonen et al., 2000a | bovine | 13 | longissimus | 8.1 – 19.5 |
| Kenny & Tarrant, 1988 | bovine | 24 | longissimus | 6.1 – 14.5 |
| Crouse et al., 1984 | bovine | 12 | longissimus | 9.0 – 15.5 |
| McVeigh et al., 1982 | bovine | 12 | longissimus | 7.4 – 18.0 |
| Onenc, 2010 | bovine | 20 | longissimus | 1.6 – 2.1 |
| current study | bovine | 33 | longissimus | 1 day mixed: 2.61 (mean) 4 day mixed: 4.33 controls: 4.77 |

*only an overall mean value was reported

CHAPTER 5

CONCLUSION & RECOMMENDATIONS

More and more frequently bull meat is being used for not only bulk packed meat used for further processing but also for collecting primal cuts more commonly associated with prime steer and heifers. In many Scandinavian countries it is unusual for male cattle to be castrated, and the majority of prime cuts are derived from bulls (Eva Wiklund, personal communication). The primary differences between the New Zealand and European systems for rearing and slaughtering these animals are the modifications that prevent mixing of bulls both on-farm and during the lead up to slaughter. The bulls are reared in individual box stalls and held in lairage at the processing facility individually (Puolanne & Aalto, 1980; Malmfors et al., 1983; Matzke et al., 1985; Mounier et al., 2008). These design features prevent mixing of unfamiliar animals and the associated aggressive behaviour that accompanies development of a hierarchical structure. Matzke et al. (1985) reported that animals maintained in individual pens before slaughter produce 4 to 5 times less dark-cutting carcasses than bulls kept in pairs.

The New Zealand situation is fairly typical of that described for this study. Uncastrated animals are raised outdoors on pasture in groups of varying sizes. Hierarchies are established and maintained. Frequently, during the lifetime of these animals the mobs are reconfigured to ensure that the majority of bulls within the group reach market weight at the same time. If these reconfigurations occur well prior to transport to slaughter, the bulls have adequate opportunity to re-establish a “pecking order”, and stress associated with this process is minimized. Additionally, as the bulls are returned to their “home” paddocks after mixing there is ample space for animals lower in the hierarchy to escape from more aggressive animals. Conflicts can be avoided. However, this scenario is not always the case. In many instances, a group may be brought into the yards only the day before slaughter and smaller animals that have not reached market weight are drafted out. The resulting group can be considered a “mixed” group, because although “new” animals have not been added, there is a high probability of a change to the social order simply by the removal of some of the bulls. This mixed group may be left in the holding yards overnight awaiting transport. Not only do the bulls seek to re-establish a hierarchy, but they must do so in a small area where conflict avoidance is

virtually impossible. This situation is made worse if animals from other mobs that have similarly reached market weight are added to the group.

The above scenario is probably a worst-case event when seeking to avoid stress-induced meat quality issues. Unfamiliar animals are mixed in an environment where there is inadequate space to allow escape or maintain recognized distances. The animals are of similar size and fighting for hierarchical dominance can be extremely aggressive. There will be limited time for social structure to be re-established as transport to slaughter will most likely occur the following morning. During this time and up until slaughter feed will not be available. Calories consumed by physical behaviours associated with establishment of social structure will not be replaced. Added to this situation are the usual slaughter period stressors such as transport, unfamiliar environments, handling (e.g. during loading and unloading), possible temperature extremes and novelty. This study supports these assumptions. The blood profile of bulls mixed twenty four hours prior to slaughter indicated that they had been more physically active during this period than the four day mixed or control bulls. In terms of meat quality, these one day mixed bulls had increased shear force measurements at 28 days post slaughter.

Much research has focused on the effects of mixing unfamiliar cattle prior to slaughter either during transport or at the abattoir. Indeed, there is little doubt that this practice is poor management of beef animals both in terms of animal welfare and meat quality outcomes. The New Zealand Animal Welfare (Sheep & Beef Cattle) Code of Welfare 2010 recommends avoiding mixing of unfamiliar animals with regards to pre-transport management. The Code recognizes that cattle may require up to seven days of “social familiarity” before transport to minimise transport stress. This study focused on a related but perhaps more pertinent aspect of pre-slaughter management. On-farm mixing prior to transport to slaughter would seem to occur with some degree of regularity. Not only is this practice outside the control of those most interested in decreasing stress but also the frequency is somewhat unrecognized by meat industry management (Greenlea livestock buyers, personal communication). In other words, slaughter premises managers may seek to prevent mixing of unfamiliar mobs at their facility, but they do not realize that mobs are arriving in an already mixed state. Their best efforts for producing a quality product may already be in vain. The study by Mounier et al. (2006) led them to conclude that “groups of bulls should be maintained

throughout finishing and for transfer to slaughter.” Warriss et al. (1984) concluded that young bulls mixed before slaughter required resting with food for 48 hours before being killed to ensure that no carcasses are produced with high pH_u. Current commercial practices do not include feeding of animals awaiting slaughter, and it is also important to note that the animals in the Warriss et al. (1984) study were fed a diet high in concentrates. The muscle glycogen concentration of these animals would most likely have been higher at the outset than those fed only pasture. Immonen et al. (2000c) reported that when compared to a low energy diet, a high energy diet seemed to protect cattle from potentially glycogen-depleting stressors. Additionally, the animals in the Warriss study (Warriss et al., 1984) were walked 20 metres from their yards to the Meat Research Institute slaughterhouse and killed immediately. They did not incur the additional commercial stresses of transport and on-plant lairage.

This project did not attempt to evaluate temperament of the bulls used in the study. Previous research has indicated that cattle with more excitable temperaments have more extensive responses to stress (Curley, 2004). Excitable cattle have also been reported to have increased incidence of dark cutting and increased shear force values (Falkenberg et al., 2005; Voisinet et al., 1997). King et al. (2006) found higher circulating concentrations of glucocorticoids in animals identified as “excitable”. Thus, it is not possible to rule out temperament rather than mixing as a cause of the effects noted.

Results of the current study indicate that more research into the effects of on-farm mixing is certainly warranted. Future studies might seek to establish a minimum timeframe during which mixing can occur without causing detrimental effects on meat quality characteristics. In order for such a study to be relevant to the New Zealand meat industry, the animals would need to be only pasture fed and incorporate the reality of additional stresses imposed from slaughter at commercial facilities. Blood profiles and muscle biopsy before, during and after mixing would be essential to determine the process of muscle glycogen depletion and recovery and establish minimum requirements.

Based on the results of the current study it is recommended that bulls not be mixed with unfamiliar animals in the period immediately prior to slaughter. Should animals from separate finishing groups need to be combined to facilitate transfer to the slaughter

premises, the new groups should be given at least four days to re-establish a hierarchy and replenish muscle glycogen reserves. Slaughter establishment operators should advise their suppliers of the adverse effects on meat quality of on-farm mixing of bulls.

APPENDIX A

Summary of repeated measures analysis showing the changes with ageing time for meat pH, drip loss and shear force.

| pH | p |
|-------------------------------|--------|
| treatment | 0.090 |
| time | < .001 |
| Time by treatment interaction | 0.270 |

| drip loss | p |
|----------------|--------|
| treatment | 0.935 |
| time | < .001 |
| time.treatment | 0.337 |

| shear force | p |
|----------------|--------|
| treatment | 0.031 |
| time | < .001 |
| time.treatment | 0.702 |

APPENDIX B

Summary of time effects.

| | 24 hours | 7 days | 28 days | p | LSD (5%) |
|-------------|---------------------|---------------------|---------------------|-----------|----------|
| drip loss | 1.287 ^c | 1.534 ^b | 1.960 ^a | p < 0.001 | 0.21 |
| shear force | 17.04 ^a | 10.21 ^b | 7.09 ^c | p < 0.001 | 1.14 |
| pH | 5.5973 ^c | 5.6204 ^b | 5.6658 ^a | p < 0.001 | 0.022 |
| purge loss | | 2.155 ^b | 3.011 ^a | p < 0.001 | 0.24 |

values listed are least squares means; different superscripted letters show the treatments as significantly different (p < 0.001) using the LSD (5%).

| | fresh | bloomed | p | LSD (5%) |
|------------|--------------------|--------------------|-----------|----------|
| L | 31.55 ^b | 32.65 ^a | p < 0.001 | 0.64 |
| a | 8.90 ^b | 9.89 ^a | p < 0.001 | 0.28 |
| b | 5.43 ^b | 6.41 ^a | p < 0.001 | 0.18 |
| hue | 31.23 ^b | 32.83 ^a | p < 0.001 | 0.34 |
| saturation | 10.43 ^b | 11.79 ^a | p < 0.001 | .032 |

values listed are least squares means; L = lightness; a = redness; b = yellowness; different superscripted letters show the treatments as significantly different (p < 0.001) using the LSD (5%).

REFERENCES

- Amadori, M., Stefanon, B., Sgorlon, S., & Farinacci, M. (2009) Immune system response to stress factors. *Italian Journal of Animal Science*, 8, 287-299.
- Anon. (2002) *Standards manual for MSA grading*, Meat and Livestock Australia Ltd, Sydney, Australia.
- Bartos, L., Franc, C. Albiston, G. & Beber, K. (1988) Prevention of dark-cutting (DFD) beef in penned bulls at the abattoir. *Meat Science*, 22, 213-220.
- Beilharz, R. G. & Zeeb, K. (1982) Social dominance in dairy cattle. *Applied Animal Ethology*, 8, 79-97.
- Bendall, J. R. (1979) Relations between muscle pH and important biochemical parameters during the post-mortem changes in mammalian muscles. *Meat Science*, 3, 143-157.
- Bendall, J. R. (1973) Postmortem changes in muscle. In G. H. Bourne (ed.) *The structure and function of muscle, Vol. II, Structure, part 2*. p. 243-309. Academic Press, New York, USA.
- Berg, A. & Haralambie, G. (1978) Changes in serum creatine kinase and hexose phosphate isomerase activity with exercise duration. *European Journal of Applied Physiology and Occupational Physiology*, 39, 191-201.
- Bermeyer, H. U. & Bernt, E. (1974) In: H. U. Bermeyer (ed.) *Methods of Enzymatic Analysis, Vol. 3*, p. 1127, Academic Press, London, UK.
- Boissy, A. & Le Niendre, P. (1990) Social influences on the reactivity of heifers: implications for learning abilities in operant conditioning. *Applied Animal Behaviour Science*, 25, 149-165.
- Bray, A. R., Graafhuis, A. E., & Chrystall, B. B. (1989) The cumulative effect of nutritional, shearing and pre-slaughter washing stresses on quality of lamb meat. *Meat Science*, 25, 59-67.
- Colditz, I. G., Ferguson, D. M., Greenwood, P. L., Doogan, V. J., Petherick, J. C. & Kilgour, R. J. (2007) Regrouping unfamiliar animals in the weeks prior to slaughter has few effects on physiology and meat quality in *Bos taurus* feedlot steers. *Australian Journal of Experimental Agriculture*, 47, 763-769.
- Costa, L. N. (2009) Short-term stress: the case of transport and slaughter. *Italian Journal of Animal Science*, 8, 241-252.
- Crouse, J. D., Smith, S. B., & Prior, R. L. (1984) Bovine muscle glycogen as affected by fasting and refeeding. *Journal of Animal Science*, 59, 384-387.

- Cunningham, J. G. (2002) Neurophysiology. In: J. G. Cunningham (ed.) *Textbook of Veterinary Physiology 3rd edition* p. 32-107. W. B. Saunders Company, Philadelphia, USA.
- Curley, K. O. (2004) Influence of temperament on bovine hypothalamic-pituitary-adrenal function. M.S. thesis, Texas A&M University, College Station, USA.
- Dreiling, C. E., Brown, D. E., Casale, L., & Kelly, L. (1987) Muscle glycogen: comparison of iodine binding and enzyme digestion. Assays and applications to meat samples. *Meat Science*, 20, 167-177.
- Egan, A. F. & Shay, B. J. (1988) Long term storage of chilled fresh meats. In *Proceedings of the 34th International Congress of Meat Science and Technology*, Brisbane.
- Emerson, R. W. (1836) *Nature*. p. 62. James Munroe and Company, Boston, USA.
- Engelking, L. R. (2004) *Textbook of Veterinary Physiological Chemistry*. Teton New Media, Jackson, WY, USA.
- Falkenberg, S. M., Miller, R. K., Holloway, J. W., Rouquette, F. M., Randel, R. D., & Carstens, G. E. (2005) Exit velocity effects on growth, carcass characteristics, and tenderness in half-blood Bonsmara steers. In *Proceedings 51st international congress of meat science and technology*, p. 29, 7-12 August 2005, Baltimore, USA.
- Febbraio, M. A., Lambert, D. L., Starkie, R. L., Proietto, J., & Hargreaves, M. (1998) Effect of epinephrine on muscle glycogenolysis during exercise in trained men. *Journal of Applied Physiology*, 84 (2), 465-470.
- Ferguson, D. M., Bruce, H. L., Thompson, J. M., Egan, A. F., Perry, D. & Shorthose, W. R. (2001) Factors affecting beef palatability – farm gate to chilled carcass. *Australian Journal of Experimental Agriculture*, 41, 879-891.
- GenStat (11th Edition) 2008. GenStat for Windows, version 11.1.0.1575. VSN International, Oxford, UK.
- Graafhuis, A. E. & Devine, C. E. (1994) Incidence of high pH beef and lamb. II Results of an ultimate pH survey of beef and sheep plants in New Zealand. In *Proceedings of the 28th meat industry research conference* p. 133-141.
- Grandin, T. (1979) The effect of pre-slaughter handling and penning procedures on meat quality. *Journal of Animal Science*, 49, (Suppl. 1), 147 (abstract).
- Grandin, T. (1989) Practical experience of solving the problem of dark-cutting beef carcasses in North America. In S. U. Fabiansson, W. R. Shorthose, & R. D. Warner (eds.), *Dark Cutting in Cattle and Sheep Proceedings of an Australian Workshop*. p. 30-41, Sydney: Australian Meat and Livestock Research and Development Corporation.
- Grandin, T. (1997) Assessment of stress during handling and transport. *Journal of Animal Science*, 75, 249-257.

- Grandin, T. (1993) Handling facilities and restraint of range cattle. In: T. Grandin (ed.) *Livestock Handling and Transport* p.75-94 CAB International, Wallingford, Oxon, UK.
- Greaser, M. L. (1986) Conversion of muscle to meat. In P. J. Bechtel (ed.) *Muscle as food*, p. 37-102. Academic Press, New York, USA.
- Greco, D. & Stabenfeldt, G. H. (2002) Endocrinology. In: J. G. Cunningham (ed.) *Textbook of Veterinary Physiology 3rd edition* p. 324-372. W. B. Saunders Company, Philadelphia, USA.
- Greenhaff, P. L., Ren, J. M., Soderlunch, K. & Hultman, E. (1991) Energy metabolism in single human muscle fibers during contractions with and without epinephrine infusion. *American Journal of Physiology*, 260 (*Endocrinology & Metabolism*, 23), E713-E718.
- Good, C. A., Kramer, H., & Somogyi, M. (1933) The determination of glycogen. *Journal of Biological Chemistry*, 100, 485-491.
- Hafez, E. S. E. & Bouissou, M. E. (1975) The behaviour of cattle. In E. S. E. Hafez (ed.), *The Behaviour of Domestic Animals* p. 247-296. Williams and Wilkins, Baltimore, USA.
- Hedge, G. A., Colby, H. D. & Goodman, R. L. (1987) *Clinical Endocrine Physiology*. p. 143. W. B. Saunders Company, Philadelphia, USA.
- Heidemann, S. R. (2002) The cell. In: J. G. Cunningham (ed.) *Textbook of Veterinary Physiology 3rd edition* p. 2-29. W. B. Saunders Company, Philadelphia, USA.
- Herdt, T. (2002) Gastrointestinal physiology and metabolism. In: J. G. Cunningham (ed.) *Textbook of Veterinary Physiology 3rd edition* p. 280-303. W. B. Saunders Company, Philadelphia, USA.
- Honikel, K. O. (1998). Reference methods for the assessment of physical characteristics of meat. *Meat Science*, 49, 447-457.
- Honikel, K. O., Ronchales, P. & Hamm, R. (1983) The influence of temperature on shortening and rigor onset in beef muscle. *Meat Science*, 8, 221-241.
- Howard, A., & Lawrie, R. A. (1956) *Studies on beef quality, parts I-III*. H.M.S.O., London, UK.
- Howard, A. & Lawrie, R. A. (1957) Studies on beef quality, V, Further observations on biochemical and physiological responses to pre-slaughter treatments. *Division of Food Preservation and Transport, Technical Paper No. 4*, 1-35.
- Huddart, H. (1975) *The Comparative Structure and Function of Muscle*. p. 3-48. Pergamon Press, Oxford, UK.

- Immonen, K. & Puolanne, E. (2000) Variation of residual glycogen-glucose concentration at ultimate pH values below 5.75. *Meat Science*, 55, 279-283.
- Immonen, K., Kauffman, R. G., Schaefer, D. M. & Puolanne, E. (2000a) Glycogen concentrations in bovine longissimus dorsi muscle. *Meat Science*, 54, 163-167.
- Immonen, K., Ruusunen, M., & Puolanne, E. (2000b) Some effects of residual glycogen concentration on the physical and sensory quality of normal pH beef. *Meat Science*, 55, 33-38.
- Immonen, K., Ruusunen, M., Hissa, K., & Puolanne, E. (2000c) Bovine muscle glycogen concentration in relation to finishing diet, slaughter and ultimate pH. *Meat Science*, 55, 25-31.
- Immonen, K., Schafer, D. M., Puolanne, E., Kauffman, R. G., & Nordheim, E. V. (2000d) The relative effect of dietary energy density on repleted and resting glycogen concentrations. *Meat Science*, 54, 155-162.
- Issekutz, B. (1984) Effect of β -adrenergic blockade on lactate turnover in exercising dogs. *Journal of Applied Physiology*, 57, 1754-1759.
- Issekutz, B. (1985) Effect of epinephrine on carbohydrate metabolism in exercising dogs. *Metabolism*, 34, 457-464.
- Jansson, E., Hjemdahl, P. & Kaijser, L. (1986) Epinephrine-induced changes in muscle carbohydrate metabolism during exercise in male subjects. *Journal of Applied Physiology*, 60, 1466-1470.
- Joyce, J. P., Bryant, A. M., Duganzich, D. M., Scott, J. D. J. & Reardon, T. F. (1975) Feed requirements of growing and fattening beef-cattle – New Zealand experimental-data compared with National Research Council (USA) and Agricultural Research Council (UK) feeding standards. *New Zealand Journal of Agricultural Research*, 18, 295-301.
- Kemp, A. & van Heijningen, A. J. M.K. (1954) A colorimetric micro-method for the determination of glycogen in tissues. *Biochemical Journal*, 56, 646-648.
- Kenny, F. J. & Tarrant, P. V. (1988) The effect of oestrus behaviours on muscle glycogen concentration and dark cutting in beef heifers. *Meat Science*, 22, 21-31.
- Kenny, F. J. & Tarrant, P. V. (1987) The behaviour of young bulls during social regrouping at an abattoir. Influence of an overhead electrified wire grid. *Applied Animal Behaviour Science*, 18, 233-246.
- King, D. A., Schuehle Pfeiffer, C. E., Randel, R. D., Welsh, T. H., Oliphint, R. A., Baird, B. E., Curley, K. O., Vann, R. C., Hale, D. S., & Savell, J. W. (2006) Influence of animal temperament and stress responsiveness on the carcass quality and beef tenderness of feedlot cattle. *Meat Science*, 74, 546-556.

- Knee, B. W., Cummins, L. J., Walker, P. J., Kearney, G. A., & Warner, R. D. (2007) Reducing dark-cutting in pasture-fed beef steers by high-energy supplementation. *Australian Journal of Experimental Agriculture*, 47, 1277-1283.
- Krisman, C. R. (1961) A method of colorimetric estimation of glycogen with iodine. *Analytical Biochemistry*, 4, 17-23.
- Lacourt, A. & Tarrant, P. V. (1985) Glycogen depletion patterns in myofibres of cattle during stress. *Meat Science*, 15, 85-100.
- Lahucky, R., Palanska, O., Mojto, J., Zaujec, K. & Huba, J. (1998) Effect of preslaughter handling on muscle glycogen level and selected meat quality traits in beef. *Meat Science*, 50, 389-393.
- Lambert, M. G., Knight, T. W., Cosgrove, G. P., Death, A. F. & Anderson, C. B. (2000) Effects of yarding and transport on muscle glycogen concentration in beef cattle. *Proceedings of the New Zealand Society of Animal Production*, 60, 124-125.
- Lambert, M. G., Knight, T. W., Cosgrove, G. P., Anderson, C. B., Death, A. F. & Fisher, A. D. (1998) Exercise effects on muscle glycogen concentration in beef cattle. *Proceedings of the New Zealand Society of Animal Production*, 58, 243-244.
- Lawrie, R. A. (1955) Residual glycogen at high ultimate pH in horse muscle. *Biochimica et Biophysica Acta*, 17, 282-290.
- Lehner, N. P. (1996) *Handbook of Ethological Methods*. University Press, Cambridge, UK.
- Lister, D. (1988) Muscle metabolism and animal physiology in the dark cutting condition. In S. U. Fabiansson, W. R. Shorthose, & R. D. Warner (eds.), *Dark Cutting in Cattle and Sheep Proceedings of an Australian Workshop*. p. 19-25, Sydney: Australian Meat and Livestock Research and Development Corporation.
- Lister, D. & Spencer, G. S. G. (1983) Energy substrate provision *in vivo* and the changes in muscle pH post mortem. *Meat Science*, 8, 41-51.
- Malmfors, G., Lundstrom, K., & Fabiansson, S. (1983) Influence of handling systems on meat quality of beef. In *Proceedings of the 29th European meeting of meat research workers (Vol. I, 70-75)*, Parma, Italy.
- Manston, R., Kitchenham, B. A. & Baldry, A. F. (1977) Influence of system of husbandry upon blood composition of bulls and steers reared for beef-production. *British Veterinary Journal*, 133, 37-45.
- Matteri, R. L., Carroll, J. A. & Dyer, C. J. (2000) Neuroendocrine responses to stress. In Moberg & Mench (eds.) *The Biology of Animal Stress*. p. 43-76 CABI Publishing, Wallingford, UK.
- Matzke, P., Alps, H., Strasser, H. & Gunter, I. (1985) Bull fattening under controlled management slaughtering conditions. *Fleischwirtschaft*, 65, 389-393.

McEwen, B. (2002) *The end of stress as we know it*. Henry Press/Dana Press, Washington, DC, USA.

McVeigh, J. M. (1980) *In vivo glycogen metabolism in bovine skeletal muscle in relation to dark-cutting in beef*. Ph.D. thesis. National University of Ireland, Dublin.

McVeigh, J. M. & Tarrant, P. V. (1982) Glycogen content and repletion rates in beef muscle, effects of feeding and fasting. *Journal of Nutrition*, 112, 1306-1314.

McVeigh, J. M. & Tarrant, P. V. (1983) Effect of propranolol on muscle glycogen metabolism during social regrouping of young bulls. *Journal of Animal Science*, 56, 71-80.

McVeigh, J. M., Tarrant, P. V. & Harrington, M. G. (1979) Influence of behavioural stress on bovine skeletal muscle glycogen content. *Biochemical Society Transactions*, 7, 539-541.

McVeigh, J. M., Tarrant, P. V. & Harrington, M. G. (1982) Behavioural stress and skeletal muscle glycogen metabolism in young bulls. *Journal of Animal Science*, 54, 790-795.

Moberg, G. P. & Mench, J. A. (2000) *The Biology of Animal Stress: Basic principles and implications for animal welfare*. CABI Publishing, Wallingford, Oxon, UK.

Mohan-Raj, A. B., Moss, B. W., Rice, D. A., Kilpatrick, D. J., McCaughey, W. J., & McLauchlan, W. (1992) Effects of mixing male sex types of cattle on their meat quality and stress-related parameters. *Meat Science*, 32, 367-386.

Mounier, L., Veissier, I., Andanson, S., Delval, E. & Boissy, A. (2006) Mixing at the beginning of fattening moderates social buffering in beef bulls. *Applied Animal Behaviour Science*, 96, 185-200.

Mounier, L., Colson, S., Roux, M., Dubroeuq, H., Boissy, A., & Veissier, I. (2008) Positive attitudes of farmers and pen-group conservation reduce adverse reactions of bulls during transfer for slaughter. *Animal*, 2:6, 894-901.

National Animal Welfare Advisory Committee (2010) *Animal Welfare (Sheep & Beef Cattle) Code of Welfare 2010*. MAF Biosecurity, Wellington, New Zealand.

Newton, K. G. & Gill, C. O. (1980) Control of spoilage in vacuum packaged dark, firm dry DFD meat. *Journal of Food Technology*, 15, 227-234.

Neyman, J. & Scott, E. L. (1960) Correction for bias introduced by a transformation of variables. *Annals of Mathematical Statistics*, 31:3, 643-655.

Nwe, T. M., Hori, E., Manda, M., & Watanabe, S. (1996) Significance of catecholamines and cortisol levels in blood during transportation stress in goats. *Small Ruminant Research*, 20, 129-135.

O'Hara, P. (2008) An overview of NAWAC's Role in Animal Welfare. *Proceedings of NZFSA Verification Authority Technical Workshop*, slide 2.

Onenc, A. (2010) The effect of post-transport electrolyte-glucose solution while in lairage on carcass and meat quality of young bulls. *Journal of Muscle Foods*, 21, 268-279.

Park, Y., Choi, Y. H., Park, C., & Kim, K. (2008) Nongenomic glucocorticoid effects on activity-dependent potentiation of catecholamine release in chromaffin cells. *Endocrinology*, 149 (10), 4921-4927.

Partida, J. A., Olleta, J. L., Campo, M. M., Sanudo, C. & Maria, G. A. (2007) Effects of social dominance on the meat quality of young Friesian bulls. *Meat Science*, 76, 266-273.

Pearson, A. M. & Young, R. B. (1989) *Muscle and meat biochemistry*. Academic Press, San Diego, CA.

Pethick, D. W., Cummins, L., Gardner, G. E., Knee, B. W., McDowell, M., McIntyre, Tudor, G., Walker, P. J., & Warner, R. D. (1999) The regulation by nutrition of glycogen in the muscle of ruminants. *Recent Advances in Animal Nutrition in Australia*, 12, 145-152.

Pethick, D. W., Rowe, J. B., & McIntyre, B. L. (1994) Effect of diet and exercise on glycogen levels in the muscle of cattle. *Proceedings of the Australian Society of Animal Production*, 20, 403.

Plotsky, P., Bruhn, T. & Vale, W. (1985a) Evidence for multifactor regulation of the adrenocorticotropin secretory response to hemodynamic stimuli. *Endocrinology*, 116, 633-639.

Plotsky, P., Bruhn, T. & Vale, W. (1985b) Hypophysiotropic regulation of ACTH secretion in response to insulin-induced hypoglycaemia. *Endocrinology*, 117, 323-329.

Pösö, A. R. & Puolanne, E. (2005) Carbohydrate metabolism in meat animals. *Meat Science*, 70, 423-434.

Price, M. A. & Tennessen, T. (1981) Pre slaughter management and dark cutting in the carcasses of young bulls. *Canadian Journal of Animal Science*, 70, 107-119.

Puolanne, E. & Aalto, H. (1980) Factors bearing on the formation of DFD meat. In *Proceedings of the 26th European meeting of the meat research workers (Vol. I, 117-129)*. Colorado Springs, USA.

Purchas, R. W. & Aungsupakorn, R. (1993) Further investigations into the relationship between ultimate pH and tenderness in beef samples from bulls and steers. *Meat Science*, 34, 163-178.

- Purchas, R. W., Yan, X. & Hartley, D. G. (1999) The influence of a period of aging on the relationship between ultimate pH and shear values of beef *m. longissimus thoracis*. *Meat Science*, *51*, 135-141.
- Richter, E. A., Ruderman, N. B., Gavras, H. Belur, E. R. & Galbo, H. (1982) Muscle glycogenolysis during exercise: dual control by epinephrine and contractions. *American Journal of Physiology*, *242* (*Endocrinology & Metabolism*, *5*), E25-E32.
- Richter, E. A., Sonne, B., Christensen, N. J. & Galbo, H. (1981) Role of epinephrine for muscular glycogenolysis and pancreatic hormone secretion in running rats. *American Journal of Physiology*, *240* (*Endocrinology & Metabolism*, *3*), E526-E532.
- Sanz, M. C., Verde, M. T., Saez, T. & Sanudo, C. (1996) Effect of breed on the muscle glycogen content and dark cutting incidence in stressed young bulls. *Meat Science*, *43*, 37-42.
- Schein, M. W. & Fohrman, M. H. (1955). Social dominance relationships in a herd of dairy cattle. *British Journal of Animal Behaviour*, *3*, 45-55.
- Scheurink, A. J. W. & Steffens, A. B. (1990) Central and peripheral control of sympathoadrenal activity and energy metabolism in rats. *Physiology & Behavior*, *48* (6), 909-920.
- Schinner, S. & Bornstein, S. (2005) Cortical-Chromaffin cell interactions. *Endocrine Pathology*, *16*, 91-98.
- Selye, H. (1939) The effect of adaptation to various damaging agents in the female sex organs in the rat. *Endocrinology*, *25*, 615-624.
- Shaw, F. D. & Tume, R. K. (1992) The assessment of pre-slaughter and slaughter treatments of livestock by measurement of plasma constituents-a review of recent work. *Meat Science*, *32*, 311-329.
- Spensley, J. C., Wathes, C. M., Waran, N. K. & Lines, J. A. (1995) Behavioural and physiological responses of piglets to naturally occurring sounds. *Applied Animal Behaviour Science*, *44*, 277 (Abstr.)
- Spriet, L. L., Ren, J. M. & Hultman, E. (1988) Epinephrine infusion enhances muscle glycogenolysis during prolonged electrical stimulation. *Journal of Applied Physiology*, *64*, 1439-1444.
- Stricklin, W. R., Graves, H. B., Wilson, L. L. & Singh, R. K. (1980) Social organization among young beef cattle in confinement. *Applied Animal Ethology*, *6*, 211-219.
- Sugden, M. C., Sharples, S. C. & Randle, P. J. (1976) Carcass glycogen as a potential source of glucose during short-term starvation. *Biochemical Journal*, *160*, 817-819.
- Tanoue, A. (2009) New topics in vasopressin receptors and approach to novel drugs: Effects of vasopressin receptor on regulations of hormone secretion and metabolisms of glucose, fat, and protein. *Journal of Pharmacological Sciences*, *109*, 50-52.

- Tarrant, P. V. (1990) Transportation of cattle by road. *Applied Animal Behaviour Science*, 28, 153-170.
- Tarrant, P. V. (1988) Animal behaviour and environment in the dark-cutting condition. In S. U. Fabiansson, W. R. Shorthose, & R. D. Warner (eds.), *Dark Cutting in Cattle and Sheep Proceedings of an Australian Workshop*. p. 8-18, Sydney: Australian Meat and Livestock Research and Development Corporation.
- Tarrant, P. V. & Lacourt, A. (1984) Effect of glucocorticoid, insulin and glucose treatment on muscle glycogen content in stressed young bulls. *British Veterinary Journal*, 140, 337-346.
- Tarrant, P. V. & Grandin, T. (1993) Cattle transport. In: T. Grandin (ed.) *Livestock Handling and Transport*. p. 109-126. CAB International, Wallingford, UK.
- Tarrant, P. V. & McVeigh, J. M. (1979) Physiological responses during percutaneous needle biopsy of bovine skeletal muscle. *Biochemical Society Transactions*, 7, 537-539.
- Tarrant, P. V. & Sherington, J. (1980) An investigation of ultimate pH in the muscles of commercial beef carcasses. *Meat Science*, 4, 287-297.
- Tatum, J. D., Belk, K. E., George, M. H., & Smith, G. C. (1999) Identification of quality management practices to reduce the incidence of retail beef tenderness problems: development and evaluation of a prototype quality system to produce tender beef. *Journal of Animal Science*, 77, 2112-2118.
- Tennessen, T., Price, M. A. & Berg, R. T. (1985) The social interactions of young bulls and steers after re-grouping. *Applied Animal Behaviour Science*, 14, 37-47.
- Thompson, J. (2002) Managing meat tenderness. *Meat Science*, 62, 295-308.
- Tsuda, T. (1994) *Livestock Physiology 1st edition*. Yokendo, Tokyo.
- Voisinet, B. D., Grandin, T., O'Connor, S. F., Tatum, J. D., & Deesing, M. J. (1997) *Bos indicus*-cross feedlot cattle with excitable temperaments have tougher meat and a higher incidence of borderline dark cutters. *Meat Science*, 46, 367-377.
- Warriss, P. D. (1990) The handling of cattle pre-slaughter and its effects on carcass and meat quality. *Applied Animal Behaviour Science*, 28, 171-186.
- Warriss, P.D., Kestin, S. C., Brown, S. N. & Wilkins, L. J. (1984) The time required for recovery from mixing stress in young bulls and the prevention of dark cutting beef. *Meat Science*, 10, 53-68.
- Webby, R. W., Fisher, A. D., Lambert, M. G., Daly, C. C., Knight, T. W. & Turner, P. (1999) The relationship between beef ultimate pH, breed of cattle, muscle glycogen and enzyme levels and animal behaviour. *Proceedings of the New Zealand Society of Animal Production*, 59, 287-290.

World Animal Health Organization (OIE), 2008, animal welfare definition adopted at the 76th OIE General Session, *Final Report*, Paris (France).

World Animal Health Organization (OIE), 2004, *Proceedings: Global conference on animal welfare: An OIE Initiative*, Paris (France).

Young, O. A., Thomson, R. D., Merhtens, V. G. & Loeffen, M. P. F. (2004) Industrial application to cattle of a method for the early determination of meat ultimate pH. *Meat Science*, 67, 107-112.