

Copyright is owned by the Author of the thesis. Permission is given for a copy to be downloaded by an individual for the purpose of research and private study only. The thesis may not be reproduced elsewhere without the permission of the Author.

ACETALDEHYDE METABOLISM IN MAMMALS

A thesis presented in partial  
fulfilment of the requirements  
for the degree of

Doctor of Philosophy  
in Biochemistry  
at  
Massey University  
New Zealand

Allan Robert STOWELL

1977

ABSTRACT

To determine the pharmacological importance of acetaldehyde in the actions of ethanol, this study was planned to define the levels of free acetaldehyde occurring in human blood during the oxidation of ethanol in the body.

Peripheral venous blood acetaldehyde levels were determined by direct assay while pulmonary blood levels were estimated from breath acetaldehyde levels by employing the blood:air partition ratio for acetaldehyde at 37°C of  $189 \pm 18$ . Pulmonary blood acetaldehyde levels were determined to obtain values for (a) acetaldehyde output from the liver and (b) acetaldehyde levels in blood likely to be reaching the brain.

Sensitive enzymic methods for the determination of acetaldehyde in human blood and breath samples were developed, allowing levels of acetaldehyde as low as 0.5  $\mu$ moles/l and approximately 0.2 nmoles/100ml to be measured in blood and breath samples respectively, using either yeast or sheep-liver aldehyde dehydrogenases. The methods were developed to be operated in semi- or fully automated modes and involved continuous-flow distillation of samples with fluorometry.

Two methodological problems associated with the direct assay of acetaldehyde in blood were studied. These were (a) the production of acetaldehyde during the deproteinization of ethanol-containing blood with perchloric acid and (b) the rapid disappearance of acetaldehyde in blood samples.

It was found that over 90% of the acetaldehyde produced during the processing of ethanol-containing human blood for assay originates from reactions occurring when red blood cells, as distinct from plasma, are treated with perchloric acid.

The disappearance of acetaldehyde which had been added to human blood samples was found to result from the rapid metabolism of acetaldehyde to acetate by red cells. By contrast, acetaldehyde formed from in vivo ethanol metabolism did not appear to be metabolized significantly in blood samples. It was suggested that acetaldehyde formed in vivo may be bound to blood components.

While human subjects were metabolizing standard 1g/kg doses of ethanol, breath acetaldehyde concentrations were found to range from 0.5 to 10.0

nmoles/100ml while peripheral whole blood acetaldehyde levels ranged from 0 - 12  $\mu$ M and peripheral plasma levels ranged from 0 - 3  $\mu$ M. Estimated pulmonary blood and hepatic venous blood levels of acetaldehyde fell within the ranges 0.9 - 19  $\mu$ M and 4.5 - 95  $\mu$ M respectively. The changes in the acetaldehyde concentrations of blood and breath during the metabolism of ethanol did not follow any identifiable pattern. However, the results obtained suggested that there was no free acetaldehyde present in the peripheral venous blood of humans metabolizing moderate doses of ethanol and the importance of acetaldehyde in the effects of ethanol in peripheral tissues may be negligible. The estimated levels of acetaldehyde in blood passing to the brain may be sufficient to exert significant pharmacological effects on the brain but further study of the binding of acetaldehyde to tissues is required before a fuller understanding of the toxic potential of acetaldehyde can be gained.

A rat-liver perfusion system, set up to study hepatic ethanol metabolism, was used to determine the nature of hepatic acetaldehyde production. Acetaldehyde production by perfused rat livers was characterized by a peak of acetaldehyde, of variable magnitude, appearing in the hepatic venous perfusate in the first 30 min of the perfusion with medium containing ethanol. After the peak in acetaldehyde production, the metabolism of ethanol by the perfused livers gave negligible amounts of acetaldehyde in the perfusates.

ACKNOWLEDGEMENTS

I wish to thank my supervisors, Professor R.D.Batt and Dr R.M. Greenway for the help they have given me throughout the course of this study. I am also pleased to acknowledge the help and advice received from all the members of the alcohol research group, especially Mr K.Couchman and Dr Y.E.Crow. Thanks are also extended to Dr O.Batt for her medical supervision and Mr T.J.Braggins and Mrs K.M.Newland for their expert technical assistance.

CONTENTS

	<u>Page</u>
Abstract	ii
Acknowledgements	iv
List of contents	v
List of figures	x
SECTION 1	
<u>INTRODUCTION</u>	
	1
SECTION 2	
<u>DEVELOPMENT OF AN AUTOMATED ENZYMIC ASSAY FOR</u>	
<u>ACETALDEHYDE IN HUMAN BLOOD SAMPLES</u>	
2-1. Introduction	5
2-2. Reagents	7
2-3. Testing the automated distillation manifold	
2-3-1. Distillation and colorimetric analysis of acetaldehyde	8
2-3-1-1. Optimization of reaction conditions	8
2-3-1-2. Automation of the MBTH method	10
2-3-2. Distillation and spectrophotometric assay of acetaldehyde	10
2-4. Distillation and enzymic assay of acetaldehyde	17
2-4-1. Initial experiments	17
2-4-2. Semiautomated assay of acetaldehyde	17
2-4-2-1. Phasing of sample collection	19
2-4-2-2. Development of fluorescence	19
2-4-2-3. Reproducibility	20
2-4-2-4. Characteristics of the distillation manifold	20
2-4-2-5. Standard curves	23
2-4-2-6. Specificity of the semiautomated assay	23
2-4-2-7. Use of yeast aldehyde dehydrogenase with the semiautomated assay	26
2-4-3. Fully automated acetaldehyde assay	28
2-4-3-1. The manifold	28
2-4-3-2. Operation of the manifold	28
2-4-4. Recovery of acetaldehyde from human blood	30
2-4-4-1. Methods	30
2-4-4-2. Results	32

	<u>Page</u>
2-4-5. Assay of blood samples containing ethanol	34
2-5. Discussion	34

## SECTION 3

FORMATION OF ACETALDEHYDE IN BLOOD SAMPLES CONTAINING  
ETHANOL DURING DEPROTEINIZATION

	36
3-1. Introduction	36
3-2. Methods	37
3-2-1. Sample preparation	37
3-2-2. Controls	38
3-2-3. Blanks	38
3-2-4. Standards	38
3-3. Results	39
3-3-1. Acetaldehyde production in controls	39
3-3-2. Acetaldehyde production in whole blood and plasma using a 50% dilution	39
3-3-3. Effect of thiourea on acetaldehyde production using a 50% dilution of blood	44
3-3-4. Effect of blood dilution on acetaldehyde production	44
3-3-5. Effect of thiourea on acetaldehyde production using a 10% dilution of blood	46
3-3-6. Effect of preincubation of ethanol with whole blood on acetaldehyde formation	46
3-3-7. Acetaldehyde production in supernatants after deproteinization	46
3-3-8. Effect of distillation temperature on acetaldehyde level	49
3-3-9. Acetaldehyde production in ox blood	49
3-4. Discussion	51

## SECTION 4

DISAPPEARANCE OF ACETALDEHYDE IN BLOOD SAMPLES

	55
4-1. Introduction	55
4-2. Materials and methods	56
4-2-1. Reagents	56
4-2-2. Determination of radioactivity	56
4-2-3. Blood samples	56
4-2-4. Sample treatment and assay methods	57
4-2-5. Use of $^{14}\text{C}$ -labelled acetaldehyde	58
4-3. Results	59

	<u>Page</u>
4-3-1. Comparison of the rates of disappearance of acetaldehyde in human whole blood and plasma samples at 4°C and 37°C	59
4-3-2. Individual variations in blood acetaldehyde disappearance rates	59
4-3-3. Effect of haemolysis on acetaldehyde disappearance in human blood	62
4-3-4. Disappearance of acetaldehyde in human blood which has been frozen and thawed	62
4-3-5. Disappearance of endogenous acetaldehyde in blood samples taken from subjects metabolizing ethanol	62
4-3-6. The effect of ethanol and acetate on the disappearance of acetaldehyde added to blood <u>in vitro</u>	66
4-3-7. Disappearance of added acetaldehyde from blood samples taken from subjects metabolizing ethanol	68
4-3-8. Fate of acetaldehyde added to human blood	68
4-3-9. Disappearance of acetaldehyde in washed red blood cell suspensions	71
4-3-10. Disappearance of acetaldehyde in ox blood	71
4-4. Discussion	71
4-4-1. Disappearance of acetaldehyde added to blood samples	71
4-4-2. Stability of acetaldehyde formed <u>in vivo</u> from ethanol	76
SECTION 5	
<u>DEVELOPMENT OF A METHOD FOR THE DETERMINATION OF</u>	
<u>ACETALDEHYDE IN HUMAN BREATH SAMPLES</u>	
5-1. Introduction	79
5-2. Methods and results	80
5-2-1. Assay of acetaldehyde in simulated breath acetaldehyde traps	80
5-2-2. Trapping of acetaldehyde present in simulated breath samples	83
5-2-2-1. Acetaldehyde trapping efficiency	85
5-2-2-2. Reproducibility and linearity of simulated breath samples	86
5-2-3. Determination of the efficiency of trapping acetaldehyde from actual breath samples	86

	<u>Page</u>
5-2-4. Reproducibility of actual breath samples	89
5-2-5. Automation of sample acidification	90
5-2-6. Fully automated breath acetaldehyde assay	90
5-2-7. Stability of samples	91
5-2-8. Determination of the partition ratio of acetaldehyde distributed between blood and air at equilibrium	91
5-2-9. Dependence of the water:air partition ratio for acetaldehyde on equilibration temperature	93
5-2-10. Determination of the variation of breath acetaldehyde concentration with the depth of expired air	96
5-2-11. Level of assayable aldehydes in spirits consumed by human volunteers	99
5-3. Discussion	100

## SECTION 6

### ACETALDEHYDE LEVELS IN THE BREATH, WHOLE VENOUS BLOOD AND PLASMA OF HUMAN SUBJECTS METABOLIZING A STANDARD

#### DOSE OF ETHANOL

	102
6-1. Introduction	102
6-2. Methods	103
6-2-1. Human subjects	103
6-2-2. Administration of ethanol to volunteers	104
6-2-3. Blood samples	104
6-2-4. Whole blood and plasma assays	104
6-2-5. Measurement of acetaldehyde and ethanol in breath samples	105
6-3. Results	106
6-3-1. Breath acetaldehyde concentrations after the ingestion of ethanol in doses of 0.5 and 1.0 g/kg body weight	106
6-3-2. Intra-individual variation in the levels of breath acetaldehyde determined after a standard dose of ethanol	108
6-3-3. Inter-individual variation in the levels of breath acetaldehyde determined after a standard dose of ethanol	108
6-3-4. Breath acetaldehyde levels in alcoholics	110

	<u>Page</u>
6-3-5. Acetaldehyde in plasma, whole venous blood and breath of human subjects metabolizing a standard dose of ethanol	110
6-3-6. Levels of acetaldehyde in peripheral blood immediately after drinking	117
6-4. Discussion	124

## SECTION 7

THE PRODUCTION OF ACETALDEHYDE BY PERFUSED RAT  
LIVERS METABOLIZING ETHANOL

	131
7-1. Introduction	131
7-2. Methods	131
7-2-1. Experimental animals and operative technique	131
7-2-2. Perfusion system	131
7-2-3. Analytical methods	132
7-3. Results and discussion	133
7-3-1. Ethanol oxidation rates	133
7-3-2. Perfusate concentrations of lactate and pyruvate	133
7-3-3. Bile production	136
7-3-4. Acetaldehyde production by the perfused livers	136

## APPENDIX I

PRODUCTION AND STORAGE OF 1-<sup>14</sup>C ACETALDEHYDE

	142
I-1. Introduction	142
I-2. Methods	142
I-2-1. Production of acetaldehyde semicarbazone from ethanol	142
I-2-2. Regeneration of acetaldehyde from its semicarbazone	143
I-3. Results	144
I-3-1. Oxidation of ethanol	144
I-3-2. Regeneration of 1- <sup>14</sup> C acetaldehyde	144

## APPENDIX II

ABBREVIATIONS

## REFERENCES

147

148

LIST OF FIGURES

<u>Figure</u>	<u>Title</u>	<u>Page</u>
2-1.	Acetaldehyde standard curve-MBTH method	9
2-2.	Analytical manifold used to automate the MBTH assay method	9
2-3.	Combined distillation and analytical manifolds used to automate the MBTH assay method	11
2-4.	Analytical manifold for the automated spectrophotometric assay of acetaldehyde	12
2-5.	Reproducibility and linearity of peaks obtained by assaying acetaldehyde standards using the manifold illustrated in figure 2-4.	12
2-6.	Combined distillation and analytical manifolds for the spectrophotometric assay of acetaldehyde	14
2-7.	Reproducibility of peaks obtained from acetaldehyde standards processed by the manifold illustrated in figure 2-6.	15
2-8.	Standard curve obtained using the combined distillation and analytical manifolds shown in figure 2-6.	16
2-9.	Effect of distillation temperature on recovery of acetaldehyde	16
2-10.	Analytical manifold for the automated enzymic assay of acetaldehyde	18
2-11.	Effect of nitrogen flow-rate on recovery of acetaldehyde	22
2-12.	Effect of distillation temperature on recovery of acetaldehyde	22
2-13.	Acetaldehyde standard curve produced using the semiautomated enzymic assay method	24
2-14.	Acetaldehyde standard curve produced using the semiautomated enzymic assay method	25
2-15.	Interference of ethanol with the semi-automated enzymic assay	27
2-16.	Analytical manifold for the fully automated enzymic acetaldehyde assay	29
2-17.	Chart recording of acetaldehyde standards assayed using the fully automated enzymic assay system	31
3-1.	Production of acetaldehyde in control samples	40
3-2.	Production of acetaldehyde in whole blood deproteinized in the presence of ethanol by a 50% dilution with 1M PCA	41

<u>Figure</u>	<u>Title</u>	<u>Page</u>
3-3.	Production of acetaldehyde in plasma deproteinized in the presence of ethanol by a 50% dilution with 1M PCA	43
3-4.	An acetaldehyde correction curve prepared by deproteinizing whole blood containing different amounts of ethanol and employing a 10% dilution of blood	47
3-5.	The effect of preincubation on the production of acetaldehyde in whole blood deproteinized in the presence of ethanol	48
3-6.	Acetaldehyde production in PCA supernatants of whole blood where ethanol has been added after deproteinization	50
4-1.	Disappearance of acetaldehyde added to human whole blood and plasma samples at 4°C and 37°C	60
4-2.	Individual variations in acetaldehyde disappearance in human blood samples at 37°C	61
4-3.	Semilogarithmic plot of the data presented in figure 4-2.	63
4-4.	The effect of haemolysis on the disappearance of acetaldehyde in human blood at 37°C	63
4-5.	Disappearance of acetaldehyde in human blood which has been frozen and thawed	64
4-6.	Disappearance of acetaldehyde in fresh ox blood	64
4-7.	Changes in the concentrations of endogenous acetaldehyde in blood samples taken from subjects metabolizing ethanol	65
4-8.	The effect of ethanol and acetate on the disappearance of acetaldehyde added to whole blood <u>in vitro</u>	67
4-9.	The disappearance of added acetaldehyde from human blood samples taken from a subject metabolizing ethanol	69
4-10.	The metabolism of 1- <sup>14</sup> C acetaldehyde by human blood in vitro	70
4-11.	Graph of haematocrit versus the half-life of acetaldehyde in human erythrocyte suspensions	72
4-12.	The disappearance of acetaldehyde in a human erythrocyte suspension	73
5-1.	Comparison of standard curves obtained by assaying simulated breath acetaldehyde traps and aqueous acetaldehyde standards	82
5-2.	Apparatus used to produce and trap simulated breath acetaldehyde samples	84
5-3.	Reproducibility of simulated breath samples	87
5-4.	Sample pumping unit used for the automatic acidification of breath acetaldehyde samples	87

<u>Figure</u>	<u>Title</u>	<u>Page</u>
5-5.	Dependence of the water:air partition ratio for acetaldehyde on equilibration temperature	95
5-6.	Variation of breath acetaldehyde and ethanol concentrations with the depth of expired air	98
6-1.	Blood ethanol and breath acetaldehyde levels of two male subjects after the consumption of ethanol loads of 0.5 and 1.0 g/kg	107
6-2.	Variation in the breath acetaldehyde concentrations of one individual, after three standard 1.0 g/kg ethanol loads	109
6-3 a to e.	Inter-individual variation in the levels of breath acetaldehyde determined after a standard dose of ethanol	111-115
6-4.	Breath acetaldehyde levels versus blood ethanol concentrations in alcoholic patients	116
6-5 a to i.	Acetaldehyde in plasma, whole venous blood and pulmonary blood of human subjects metabolizing a standard dose of ethanol	118-122
6-6.	Levels of ethanol and acetaldehyde in peripheral venous blood immediately after initiation of ethanol consumption	123
7-1.	Perfusate lactate levels during the perfusion of rat livers	134
7-2.	Perfusate pyruvate levels during the perfusion of rat livers	134
7-3.	Change in the lactate:pyruvate ratio of the perfusion medium during the perfusion of rat livers	135
7-4.	Changes in bile flow-rates during perfusion of rat livers	137
7-5.	The appearance of acetaldehyde in the perfusate leaving rat livers metabolizing ethanol	138
7-6.	Scatter diagram of peak acetaldehyde concentration versus ethanol clearance rate for perfused livers	140

## SECTION 1

INTRODUCTION

The oxidation of ethanol in mammals produces acetaldehyde which has a reactivity and toxicity much greater than that of ethanol itself (Truitt and Duritz, 1967; Truitt and Walsh, 1971; Herdtlass, 1973; Walsh, 1971). Acetaldehyde causes a number of pharmacological effects in tissues of experimental animals both in vitro and in vivo (for reviews see Truitt and Walsh, 1971; Deitrich, 1976) and an accumulation of acetaldehyde in the blood of human subjects is believed to be responsible for the adverse effects produced in the disulfiram-ethanol reaction (for review see Kitson, 1977). The toxicity of acetaldehyde relative to ethanol, and the described pharmacological activities of this compound have led to speculation that acetaldehyde may be important in the development of physical dependence on ethanol and may possibly be involved in the production of adverse side-effects associated with ethanol consumption in man (Rahwan, 1974; Rahwan, 1975; Deitrich and Erwin, 1975; Hasumara et al, 1975; Raskin, 1975; Deitrich, 1976).

The finding that strains of mice and rats having different preferences for ethanol have associated differences in blood levels of acetaldehyde (Sheppard et al, 1970; Eriksson, 1973) has provided evidence for a relationship between a biochemical variable and a behavioural effect which may be related to the development of dependence on ethanol.

Ortiz et al (1974) have recently shown that acetaldehyde alone can induce withdrawal symptoms characteristic of those induced by chronic ethanol administration and suggested, on the basis of this finding, that acetaldehyde may have an important role in the development of addiction to ethanol.

Hasumara et al (1975) have found that chronic ethanol consumption by rats significantly reduces the capacity of rat-liver mitochondria to oxidize acetaldehyde and have suggested that this effect could lead to increased acetaldehyde levels, resulting in liver injury which is known to occur as a result of chronic ethanol consumption in man (Lieber, 1975). The recent findings of Korsten et al (1975) that blood acetaldehyde levels in human alcoholics appeared to be significantly higher than those of normal subjects, when both groups were administered the same intravenous dose of ethanol, have further implicated acetaldehyde in the development of addiction to ethanol.

Although such studies suggest a possible role for acetaldehyde in the actions of ethanol, more information is required on the actual levels of free circulating acetaldehyde present in mammals while ethanol is being metabolized in addition to data on levels of acetaldehyde at potential sites of action. If these in vivo levels are not sufficiently high to produce pharmacological effects, then the significance of acetaldehyde in the effects produced by ethanol might be questioned. The need for additional information has led to much recent work being carried out to precisely define the levels of acetaldehyde present in different organs and in the different areas of the circulatory systems of rats and mice while these animals have been metabolizing different doses of ethanol.

The results of these studies have generally shown that acetaldehyde, unlike ethanol (Kalant, 1971), is not evenly distributed throughout the water phase of the mammalian body and large differences may exist between the levels of acetaldehyde at its main site of production in the liver and sites of its possible action such as the brain. For example, Kesäniemi (1974) has found that no acetaldehyde exists in the milk of lactating women after ethanol administration even though this compound may be measured in the peripheral blood of these subjects. By contrast, ethanol was found to reach concentrations in milk similar to those found in blood. In pregnant rats metabolizing ethanol, no acetaldehyde could be found in foetal tissue and the levels of acetaldehyde in placental tissue was only 25% of the acetaldehyde content of the maternal aortic blood (Kesäniemi and Sippel, 1975).

Interest in the effect of ethanol on the central nervous system has led to determination of acetaldehyde levels in brain tissue of experimental animals metabolizing ethanol and these levels have been found to vary, depending on the area of the brain studied (Kiessling, 1962a,b). More recent studies have indicated that the acetaldehyde level in cerebral blood and brain may differ in mice (Ortiz et al, 1974; Lin, 1975; Tabakoff et al, 1976) and Sippel and Eriksson (1975) have shown that the level of acetaldehyde in the brains of rats metabolizing ethanol is much lower than the level in cerebral blood and does not rise appreciably until the level of acetaldehyde in cerebral blood reaches a relatively high threshold level.

Acetaldehyde levels in liver tissue, hepatic venous blood, arterial blood and peripheral venous blood have been compared in rats and it has been found that the concentration of acetaldehyde in blood drops markedly after the blood leaves the liver (Marchner and Tottmar, 1976; Tottmar and Marchner, 1976; Forsander et al, 1969; Eriksson and Sippel, 1977).

The large differences in acetaldehyde levels found between different tissues, and blood from different areas of the body have been attributed to

the extrahepatic metabolism of acetaldehyde (Eriksson and Sippel, 1977) and the demonstrated presence of aldehyde dehydrogenase activity in numerous extrahepatic tissues of the rat (Deitrich, 1966) supports this suggestion.

If the extrahepatic metabolism of acetaldehyde in humans is similar to that in rats then the measurement of acetaldehyde levels in the blood flowing through peripheral veins may not be useful when trying to determine the levels of acetaldehyde which occur in potentially sensitive organs such as the brain. It is important to obtain estimates of the levels of acetaldehyde in blood (a) leaving the liver, in order to determine the maximum toxic potential of acetaldehyde in the human body, and (b) presented to the brain, since current theories relating to the involvement of acetaldehyde in the development of addiction to ethanol involve interaction of acetaldehyde with components of the central nervous system (Rahwan, 1975; Deitrich, 1976). To date, these have not been determined in humans and the few studies of acetaldehyde blood levels in humans which have been carried out have involved measurement of acetaldehyde in peripheral venous blood only.

Due to the technical and ethical constraints of sampling blood from the hepatic vein or carotid artery in humans, it was decided to measure acetaldehyde in breath and extrapolate to the required blood levels assuming that (a) acetaldehyde in pulmonary blood is in equilibrium with alveolar air so that measurement of the latter and application of Henry's law would predict the former,

(b) pulmonary blood is unchanged in composition in the few seconds it takes to be pumped into the carotid arteries and therefore the brain is exposed to the acetaldehyde levels in the lung, and (c) hepatic vein blood is diluted about five-fold with venous blood from the periphery by the time it reaches the pulmonary artery (Green, 1950). From this it is possible to estimate likely hepatic vein levels from measured levels in the lungs and peripheral veins.

When this study was planned there had been only one published study of acetaldehyde levels in the breath of humans metabolizing ethanol (Freund and O'Hollaren, 1965) and in this study no calculation of pulmonary blood levels were made. For this calculation, it is necessary to know the blood:air partition ratio for acetaldehyde and this constant had not been determined. One of the aims of this study was therefore, to determine this constant and use it to estimate pulmonary blood acetaldehyde concentrations from breath acetaldehyde concentrations.

In order to determine the extent of extrahepatic acetaldehyde metabolism it was decided to measure the level of acetaldehyde in pulmonary and

peripheral blood simultaneously, using a direct blood assay method for the determination of peripheral blood acetaldehyde levels.

Although there appears to be no doubt that acetaldehyde does occur in the blood of humans metabolizing ethanol, because of methodological problems associated with the determination of acetaldehyde in blood, much of the published work on human blood acetaldehyde levels is open to question.

The unreliability of published blood acetaldehyde levels determined by chemical assay methods has been reviewed by Duritz and Truitt (1964) and although currently employed gas chromatographic assay methods have the necessary specificity and sensitivity for the accurate determination of acetaldehyde (Duritz and Truitt, 1964; Eriksson, 1977), the processing of blood samples prior to assay by the gas chromatographic technique has been found to result in the production of 'artefactual' acetaldehyde which is not related to the in vivo metabolism of ethanol (Sippel, 1972; Eriksson, 1975). A study of this and other methodological problems associated with the assay of acetaldehyde, specifically in human blood, was considered essential to obtain reliable estimates of the levels of acetaldehyde derived solely from the in vivo metabolism of ethanol.

SECTION 2

DEVELOPMENT OF AN AUTOMATED ENZYMIC ASSAY FOR ACETALDEHYDE IN HUMAN BLOOD SAMPLES.

2-1. INTRODUCTION.

To carry out the planned study, an accurate, sensitive and specific method for the assay of acetaldehyde in human blood samples was required and since it was expected that large numbers of samples would need to be processed it was considered necessary for the method to be rapid, reliable and simple to use.

The method most commonly used for blood acetaldehyde estimations involves gas chromatography (Duritz and Truitt, 1964; Korsten et al, 1975; Eriksson et al, 1975) and this technique has been used in this laboratory (Couchman, 1974) for the simultaneous determination of ethanol and acetaldehyde in human blood samples. Although sensitive and specific, gas chromatography has not been completely reliable, mainly because of the binding of acetaldehyde to column packings. This, and other problems associated with gas chromatographic estimations of acetaldehyde were summarized by Crow (1975) who decided to develop an alternative enzymic assay for acetaldehyde based on the fluorometric measurement of NADH, following the diffusion of acetaldehyde from deproteinized blood samples into an enzyme-containing assay system (Crow, 1975). The enzyme used was sheep-liver aldehyde dehydrogenase and diffusion was adopted to eliminate interference by non-volatile compounds which might be capable of producing fluorescence in the reagent mixture. When the method was used without modification, in the present study, it was found to be unsatisfactory for the following reasons:-

The procedures were time-consuming, because

- (i) all sample tubes had to be carefully shaken individually at least twice during the period required for diffusion to take place,
- (ii) the blank fluorescence of all sample tubes had to be read before the assay,
- (iii) continued correction for a rising baseline was necessary while reading the samples

and (iv) working at a high sensitivity on the fluorometer resulted in a low signal to noise ratio and it was necessary to monitor the fluorescence of each tube for about thirty seconds using a chart recorder in order to obtain accurate readings.

Because of these procedural difficulties only a relatively small number of samples could be assayed at one time. In addition, fluorometer tubes could be re-used no more than twice, before differences in blank fluorescence readings were of the same order as fluorescence levels due to the samples.

Some of these problems could have been avoided if a larger sample size could have been used, permitting a lower sensitivity setting on the fluorometer, but the diffusion step could not be used reliably with a sample size greater than about 100  $\mu$ l.

It had been suggested by Lundquist (1958) that distillation of biological samples (such as deproteinized blood supernatants) followed by fluorometric determination of enzymically produced NADH might provide a sensitive method for the assay of acetaldehyde. While he favoured distillation only as a means of separating acetaldehyde from non-volatile substances which might interfere with the assay, it was considered that if the diffusion step in the assay developed by Crow was replaced by distillation, a larger sample could be used and a sufficient increase in sensitivity might be achieved to allow for the use of lower fluorometer sensitivity settings. The conventional distillation of large numbers of samples would have been a time-consuming procedure, and it was therefore decided to attempt to set up an automated continuous-flow distillation apparatus capable of processing large numbers of samples. Such a system had been described for the determination of volatile aldehydes and ketones (Duncombe and Shaw, 1966) so this procedure was adapted to replace the diffusion step in the assay described by Crow and the whole assay was completely automated.

The large range of published values for blood acetaldehyde concentrations in humans metabolizing ethanol (Crow, 1975) led to some uncertainty when attempts were made to establish a maximum sensitivity level for the assay. However, when this study began, the lowest measured levels of blood acetaldehyde in the literature were approximately 1 - 3  $\mu$ M and it was decided that the assay should be capable of detecting at least 0.5  $\mu$ M to allow for the dilution of blood samples during deproteinization; found to be essential when assaying acetaldehyde in human blood.

The automated distillation manifold of Duncombe and Shaw (1966) was designed to operate with samples containing relatively large concentrations of acetaldehyde (approximately 100 - 2,000  $\mu\text{M}$ ) and it was anticipated that many modifications could be necessary before it would operate satisfactorily with samples containing acetaldehyde in the range found in human blood. Since the supply of aldehyde dehydrogenase was limited while the development work was proceeding, the use of an alternative, inexpensive analytical method in conjunction with the distillation system was necessary to determine the characteristics of this system while conserving enzyme.

Of the chemical methods available for the assay of aldehydes, an assay based on the reaction of aliphatic aldehydes with 3-methyl-2-benzothiazolone hydrazone to form a blue dye (Hauser and Cummins, 1964) seemed to be the most suitable in terms of sensitivity, simplicity and reagent cost. Accordingly, this method was chosen initially to test the efficiency and practicability of the distillation system before attempting to use the potentially more sensitive enzymic method.

## 2-2. REAGENTS.

All chemicals used were reagent grade except for tetrasodium pyrophosphate (analytical grade) and all solutions were prepared in distilled, deionized water.

Acetaldehyde and  $\text{NAD}^+$  were obtained from BDH Chemicals Ltd. (Poole, United Kingdom). Acetaldehyde was redistilled before use and stored at  $4^\circ\text{C}$  for up to six months. Dilute solutions were freshly prepared when required.

3-methyl-2-benzothiazolone hydrazone (MBTH) and yeast aldehyde dehydrogenase (E.C. 1.2.1.5) grade II were obtained from Sigma Chemical Co., St. Louis, Mo., U.S.A.

Sheep-liver cytoplasmic aldehyde dehydrogenase (E.C. 1.2.1.3) was prepared by the methods described by Crow et al., (1974) and solutions containing 500 - 3,000 enzyme units<sup>1</sup>/ml were stored at  $4^\circ\text{C}$  for up to two months in 0.05M phosphate buffer pH 7.3 and 0.1% v/v 2-mercaptoethanol.

- 
1. 1 unit (defined by Crow (1974)) = 0.001 absorbance units/min. when measured at room temperature and is equivalent to the formation of 0.483 nmoles  $\text{NADH}$ /min. in a total volume of 3ml.

## 2-3. TESTING THE AUTOMATED DISTILLATION MANIFOLD.

### 2-3-1. Distillation and colorimetric analysis of acetaldehyde.

The characteristics of the colorimetric aldehyde assay employing 3-methyl-2-benzothiazolone hydrazone (MBTH) were determined manually before setting up an automated system. The colour development in this assay is dependent on the condensation of MBTH with acetaldehyde and an oxidation step in which the condensation product is oxidized by ferric ions to form a coloured compound which has an absorption maximum at 666 nm.

#### 2-3-1-1. Optimization of reaction conditions.

Aqueous solutions used for the assay were:

MBTH 0.05% w/v.

FeCl<sub>3</sub>/sulphamic acid 1% / 1.6% w/v. (oxidizing reagent)

Acetaldehyde standards (17.7 - 355 μM)

In the reaction, 0.2 ml of the acetaldehyde standard solution was preincubated with 3 ml MBTH followed by a further incubation after the addition of 0.6 ml of the oxidizing reagent. The effects of time and temperature on the two reactions were determined as follows:-

After the reaction of MBTH and acetaldehyde for 1h. at room temperature (Hauser and Cummins, 1964), the temperature dependence of the oxidation reaction was examined by following the absorbance of the complete reaction mixture over a period of 10 min. at both room temperature and 60°C. At room temperature, 9 min. elapsed before a full colour development was obtained while at 60°C colour development took less than 1 min. although some turbidity occurred. Cloudiness appeared at any temperature above 30°C so it was decided to use a 10 min. incubation period at room temperature for the oxidation step. Using these conditions, the condensation reaction was found to be complete in less than 10 min. if an incubation temperature of 95°C was used for this step. Cooling of the reaction mixture to below 30°C was necessary before the addition of the oxidizing reagent so that turbidity in the reagent mixture was avoided. The simplicity of the method and the short reaction times were considered ideal for a simple automated assay.

A standard curve was produced using the optimum incubation conditions described above (Fig. 2-1). The absorbance of all samples was read at 666 nm against a blank containing 0.2 ml of water in place of the acetaldehyde standard.

FIGURE 2-1. ACETALDEHYDE STANDARD CURVE - MBTH METHOD.

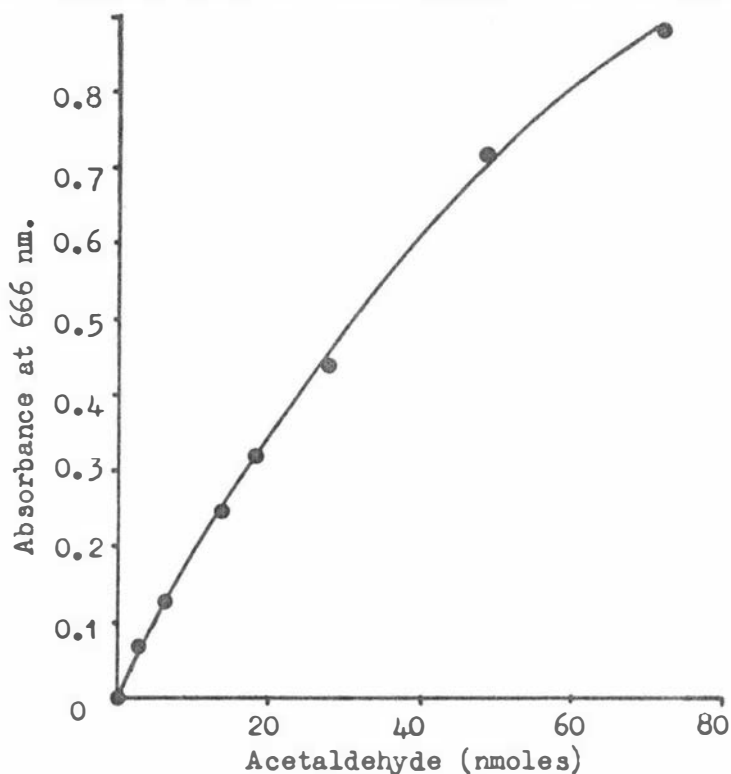
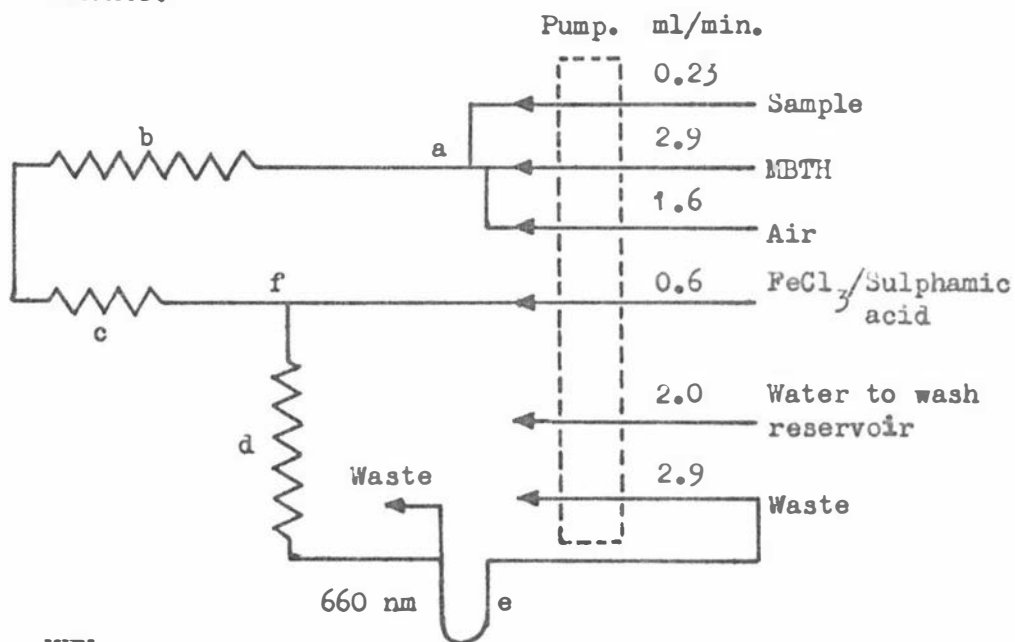

FIGURE 2-2. ANALYTICAL MANIFOLD USED TO AUTOMATE THE MBTH ASSAY METHOD.



KEY

- a. H3 cactus.
- b. Double mixing coil in a heating bath at 95°C.
- c. Single mixing coil in a water bath at 20°C.
- d. Two double mixing coils in a water bath at 20°C.
- e. Colorimeter with debubbler and 1 ml flow cuvette.
- f. D1 cactus.

### 2-3-1-2. Automation of the MBTH method.

The MBTH method described in the previous section was reproduced, approximately, in the autoanalyzer manifold shown in Fig. 2-2. using standard Technicon components.

Separation of peaks from aqueous acetaldehyde standards of 355 and 178  $\mu\text{M}$  was adequate at a sampling rate of 60/h. with a 2:1 sample: wash ratio. The transit time for samples was 5 min.

This manifold was then linked to a modified version of Duncombe and Shaw's distillation manifold, shown diagrammatically in Fig. 2-3 the sample pumping rate being increased to allow for incomplete distillation. Using a distillation temperature of 85°C, a constant N<sub>2</sub> flow-rate of about 200 ml/min., a sampling rate of 40/h. (2:1 sample: wash ratio) and acetaldehyde standards of 355 and 178  $\mu\text{M}$ , a chart recording of discrete peaks was produced, showing that acetaldehyde was being transferred in the distillation apparatus from the sample to the reagent solution. However, the peaks were not well separated and occurred on a rising baseline. Better separation of the peaks was achieved by placing water-filled cups between the sample cups in the sampler tray, and the rising baseline, which appeared to be caused by precipitation of some material in the flow cuvette of the colorimeter, was partially avoided by increasing the sulphamic acid concentration to 2.5% and decreasing the MBTH concentration to 0.02%. Nevertheless, peak reproducibility was poor, the rising baseline could not be avoided entirely and tailing of peaks occurred. Furthermore, these problems were found to occur just as much when the analytical manifold was operating alone as when the distillation and analytical manifolds were combined. After many manifold and reagent changes (including the use of Triton X100 and 'Brij 35'<sup>1</sup> in the reagent line) did not produce a satisfactory solution to the problems described, it was decided to couple the distillation manifold to a simpler though less sensitive analytical method described by Burbridge et al (1950).

### 2-3-2. Distillation and spectrophotometric assay of acetaldehyde.

An analytical manifold based on the manual assay method of Burbridge et al was first constructed and tested (Fig. 2-4).

---

1. Polyoxyethylene lauryl ether. (BDH Chemicals Ltd., Poole, U.K)

FIGURE 2-3. COMBINED DISTILLATION AND ANALYTICAL MANIFOLDS USED TO AUTOMATE THE MBTH ASSAY METHOD.

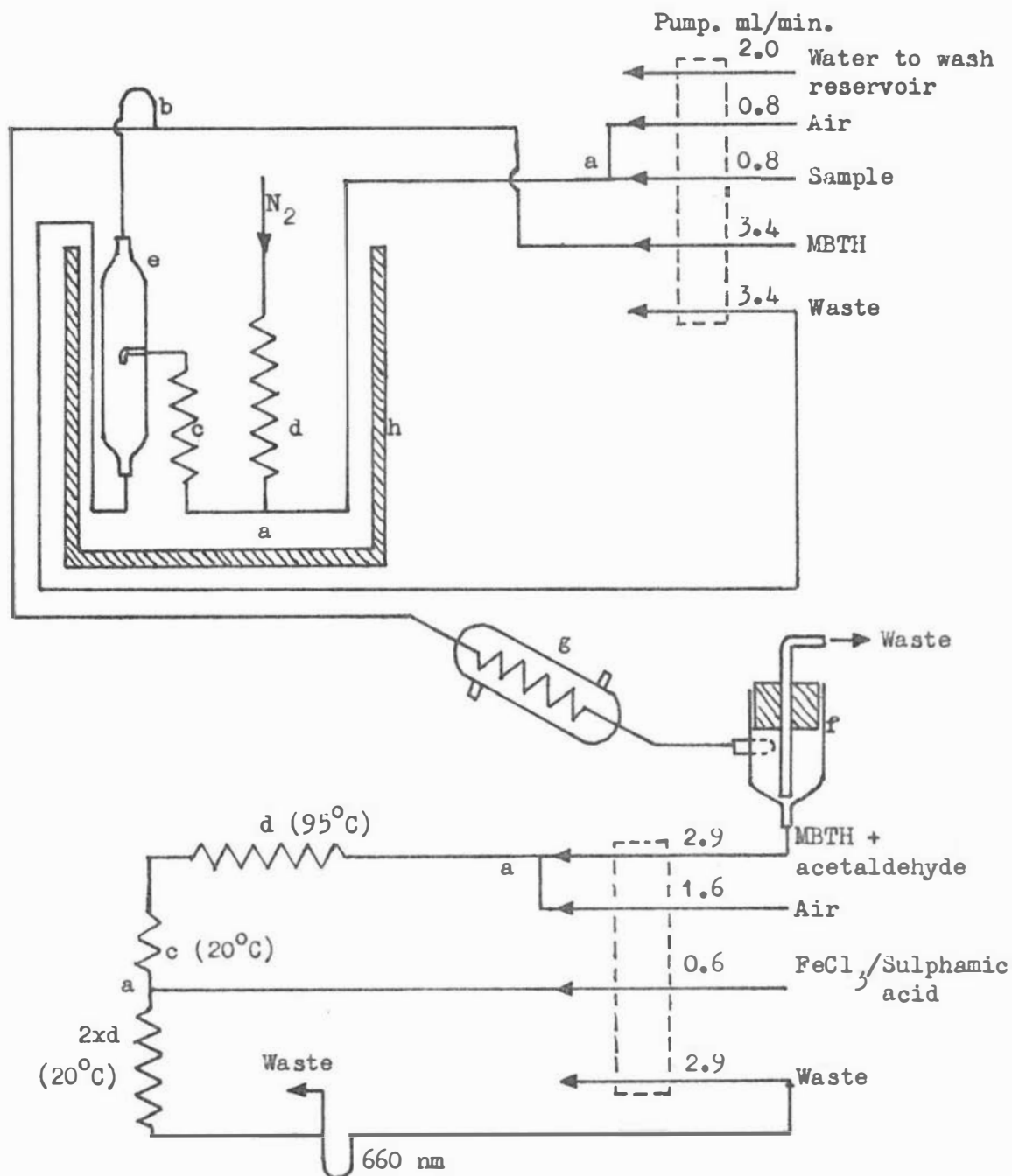

KEY

- |                        |  |
|------------------------|--|
| a. D1 cactus.          | e & f. Gas/liquid separators described by Duncombe and Shaw (1966) |
| b. D0 cactus.          | g. Jacketed single mixing coil; tap-water cooled.                  |
| c. Single mixing coil. | h. Heating bath.   |
| d. Double mixing coil. |  |

FIGURE 2-4. ANALYTICAL MANIFOLD FOR THE AUTOMATED SPECTROPHOTOMETRIC ASSAY OF ACETALDEHYDE.

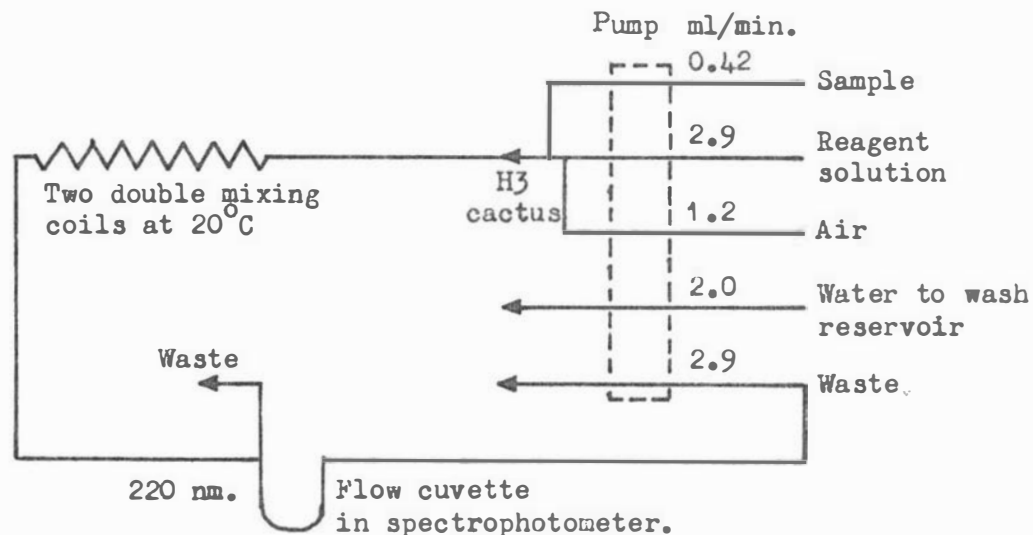
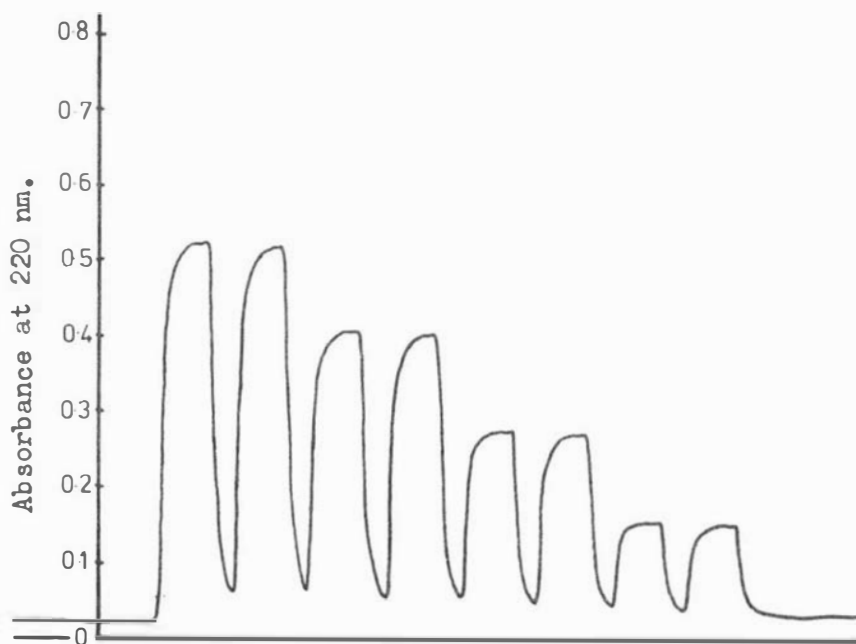

FIGURE 2-5. REPRODUCIBILITY AND LINEARITY OF PEAKS OBTAINED BY ASSAYING ACETALDEHYDE STANDARDS USING THE MANIFOLD ILLUSTRATED IN FIGURE 2-4.



Sampling rate = 30/h., sample:wash ratio = 2:1.  
 The peaks represent aqueous acetaldehyde standards of 355, 266, 178, and 89 μM, sampled in duplicate.

This method involves the measurement of the absorbance at 220 nm of acetaldehyde semicarbazone which is formed rapidly at room temperature from acetaldehyde and semicarbazide in aqueous solution at pH 7.0. A Unicam SP 500 spectrophotometer with a 1ml quartz flow cuvette was employed. One reagent solution only was used for the assay and consisted of a buffered semicarbazide solution containing 6.7 mM semicarbazide hydrochloride, 60 mM  $\text{NaH}_2\text{PO}_4$  and 140 mM  $\text{Na}_2\text{HPO}_4$ . Acetaldehyde standards used were 89 - 355  $\mu\text{M}$ . As shown in Fig. 2-5, this manifold operated satisfactorily within the range of standards used, producing a linear response, good peak reproducibility and stable baselines. Having shown that the analytical manifold alone was satisfactory it was combined with the distillation manifold previously described with minor changes in pumping rates as shown diagrammatically in Fig. 2-6.

Using this system, satisfactory washouts between samples were obtained, without the requirement for water cups between samples, using a sampling rate of 40/h. and a 2:1 sample:wash ratio. Peak reproducibility was good and a linear standard curve was produced (see Figs. 2-7 and 2-8).

The efficiency of distillation at different temperatures was studied by sampling the high standard in duplicate at eight different heating bath temperatures, keeping other assay conditions constant. From Fig. 2-9 it can be deduced that the heating bath needs to be only at 80°C for optimum distillation efficiency.

Compared to an equivalent manual method in which the reagent mixture and acetaldehyde samples were mixed directly without distillation, the relative efficiency of the automated method, including the distillation step, was calculated to be 76% at a heating-bath temperature of 80-90°C.

Although this system was not suited to the assay of acetaldehyde in human blood because it lacked the necessary sensitivity and specificity, the results obtained were very encouraging in showing that the distillation manifold functioned extremely well with sample acetaldehyde concentrations about ten times lower than those for which it was specifically designed. However, in order to produce an assay with the desired sensitivity, the distillation manifold was required to handle samples containing a further ten-fold lower concentration of acetaldehyde. To evaluate the distillation step at lower levels of acetaldehyde, it was decided to develop an autoanalyzer manifold based on an enzymic oxidation of acetaldehyde.

FIGURE 2-6. COMBINED DISTILLATION AND ANALYTICAL MANIFOLDS FOR THE SPECTROPHOTOMETRIC ASSAY OF ACETALDEHYDE.

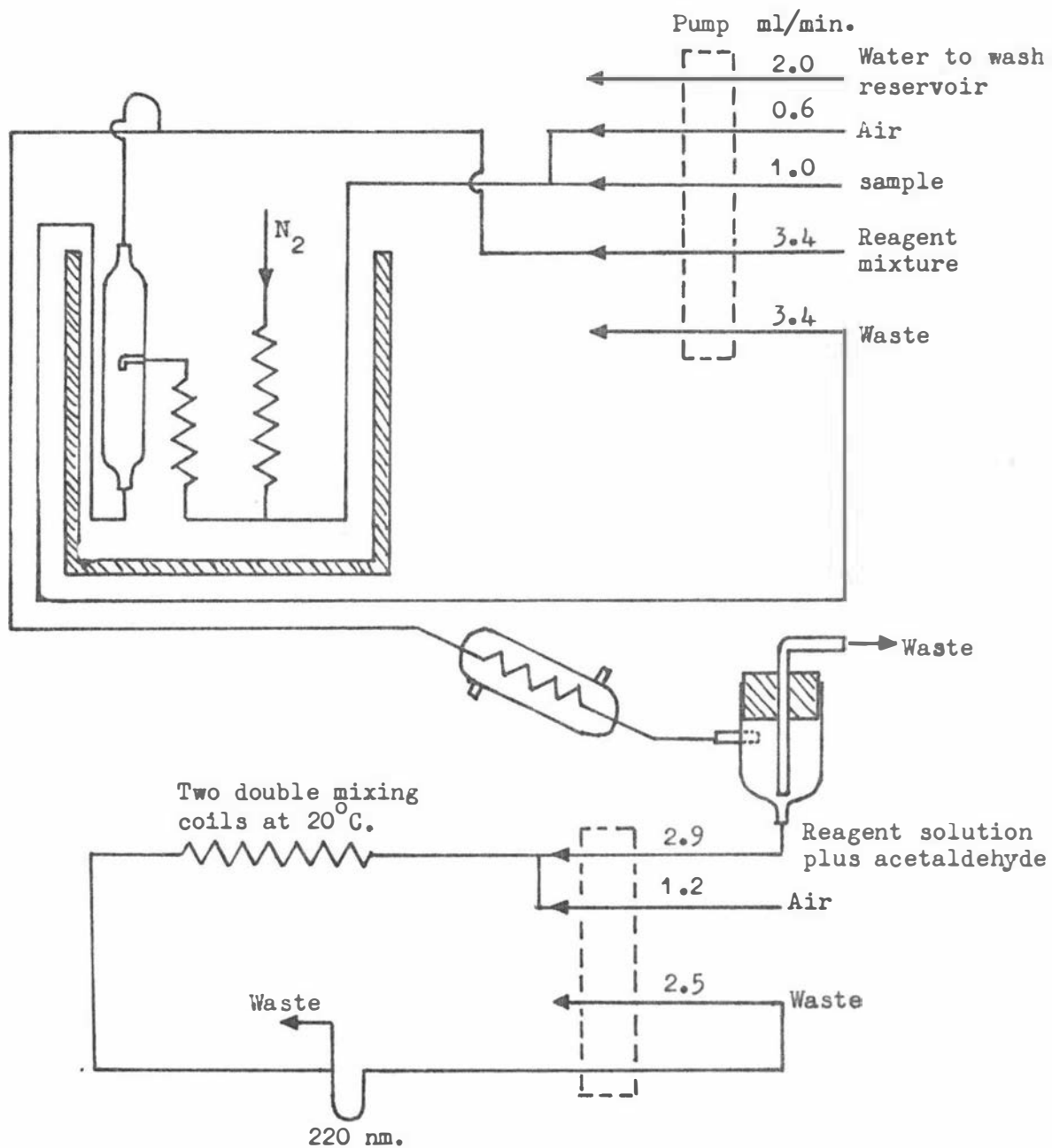
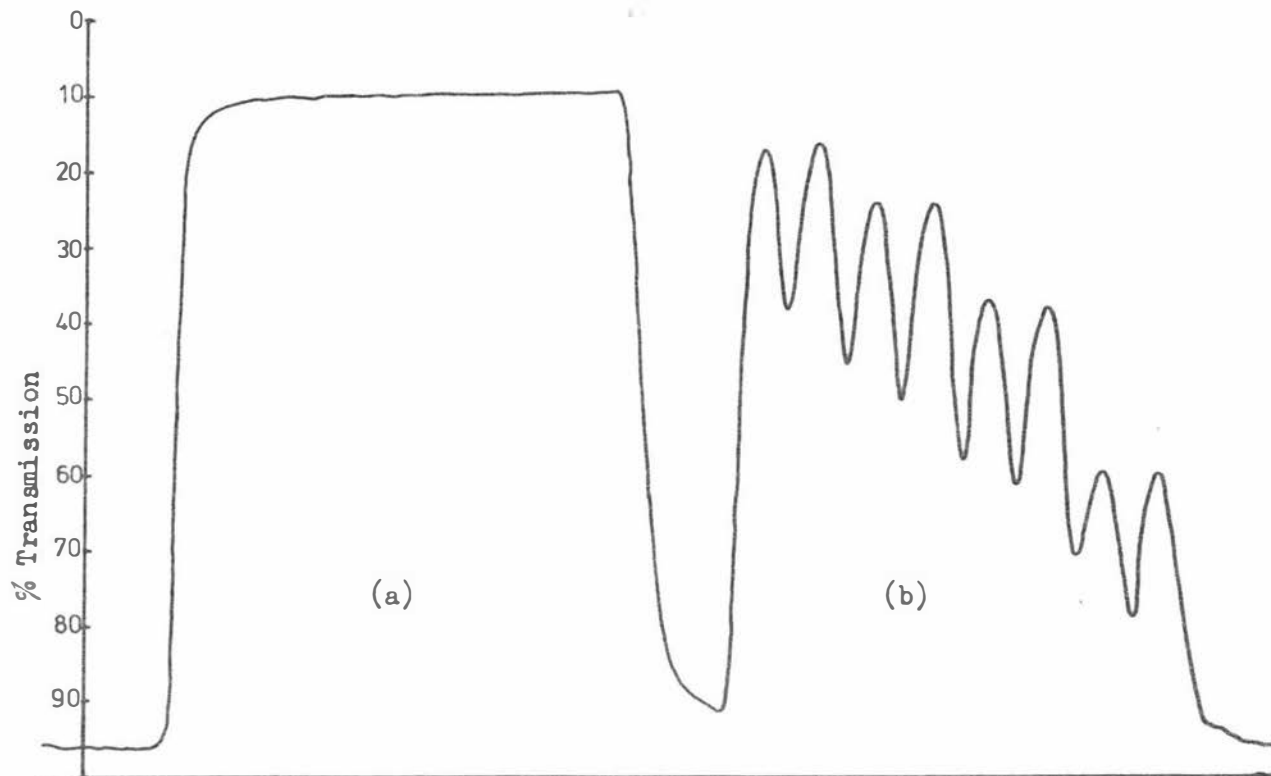

FIGURE 2-7. REPRODUCIBILITY OF PEAKS OBTAINED FROM ACETALDEHYDE STANDARDS PROCESSED BY THE MANIFOLD ILLUSTRATED IN FIGURE 2-6.



- (a) 355  $\mu\text{M}$  aqueous acetaldehyde standard sampled continuously for approximately 12 min.  
(b) Aqueous acetaldehyde standards of 355, 266, 178 and 89  $\mu\text{M}$ , sampled in duplicate.  
Sampling rate = 40/h. and sample:wash ratio = 2:1.

FIGURE 2-8. STANDARD CURVE OBTAINED USING THE COMBINED DISTILLATION AND ANALYTICAL MANIFOLDS SHOWN IN FIGURE 2-6.

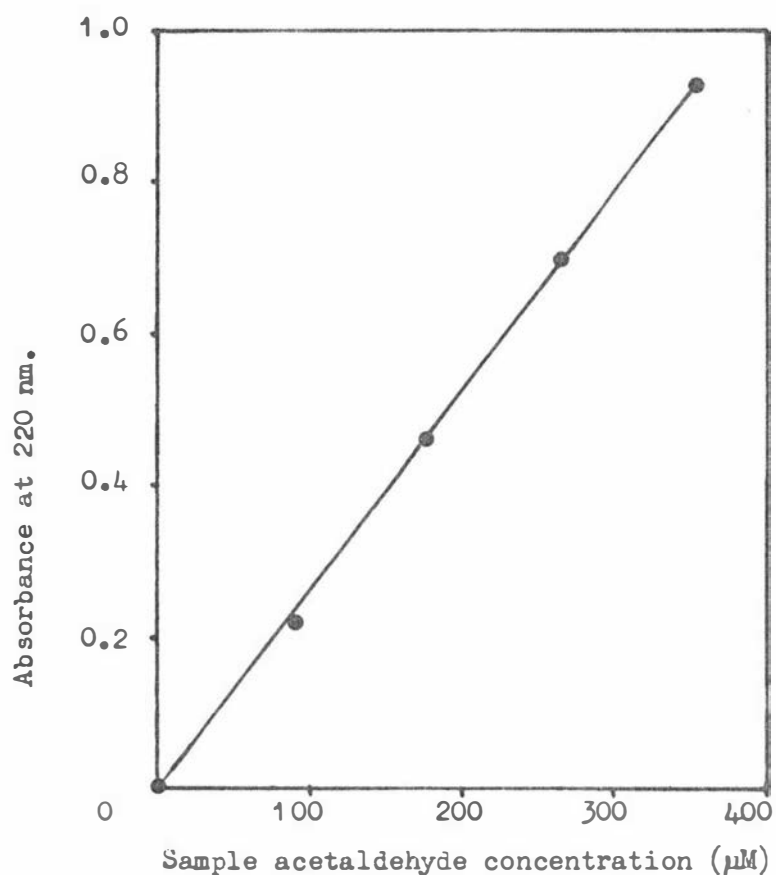
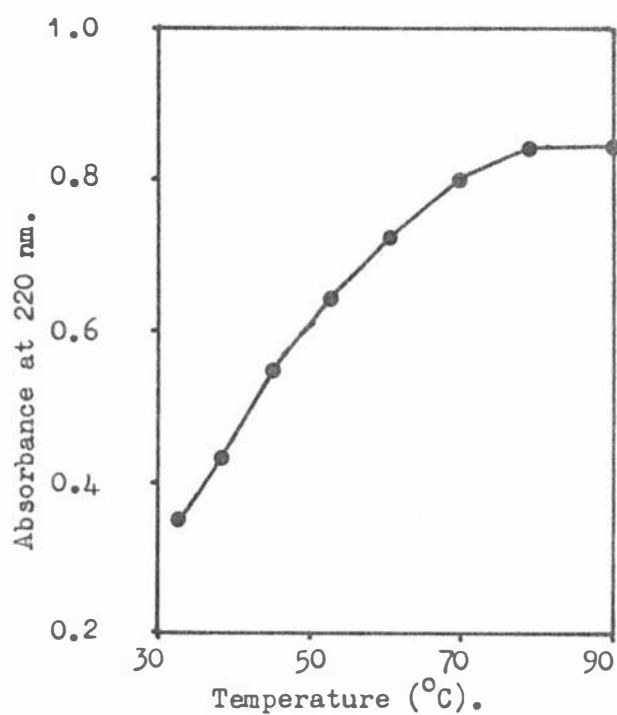

FIGURE 2-9. EFFECT OF DISTILLATION TEMPERATURE ON RECOVERY OF ACETALDEHYDE.



See Section 2-3-2 for experimental details.

## 2-4. DISTILLATION AND ENZYMIC ASSAY OF ACETALDEHYDE.

### 2-4-1. Initial experiments.

An automated analytical manifold, in which the reagents described by Crow (1975) would be used, was constructed to determine whether sensitivity in the range required for blood analysis could be obtained (Fig. 2-10). Using this manifold with acetaldehyde standards in the range of 1 - 10  $\mu\text{M}$ , satisfactory peak heights were obtained over the whole range, indicating that the sensitivity of the method was adequate. Peak height reproducibility however, was very poor, even when 0.1% Triton X100 was included in the buffer (higher concentrations of Triton were found to inhibit the enzyme). Using this manifold, reproducible peak heights could not be obtained, but when it was combined with the distillation manifold, as described for the MBTH and semicarbazone assays, peak shape and height reproducibility were found to be comparable to those from the analytical manifold operated independently. The sensitivity of the combined system was also satisfactory. This suggested that the distillation system was operating satisfactorily at low acetaldehyde concentrations. To improve the operation of this system without an excessive use of enzyme, it was decided to set up a semi-automated assay using the distillation system in conjunction with a manual enzymic assay. It was thought that by collecting the 'distillate' of each sample (combined with buffer) directly from the second gas/liquid separator (f. in Fig. 2-3) into fluorometer cuvettes, completion of the assay might be accomplished by simply adding a mixture of  $\text{NAD}^+$  and aldehyde dehydrogenase to the cuvettes and incubating until the reaction was complete. In this way, large losses of enzyme due to continuous pumping would be avoided.

### 2-4-2. Semiautomated assay of acetaldehyde.

The manifold illustrated in Fig. 2-3 was set up excluding the analytical section and with the following changes in the distillation section: (i) the sample and air pumping rates were 1.6 and 0.6 ml/min. respectively.

- (ii) 15 mM pyrophosphate buffer pH 9.3 was pumped in the reagent line instead of the MBTH reagent.
- (iii) the pumping tube connected to the base of the gas/liquid separator (f) was pumping buffer combined with acetaldehyde from the samples and 12 x 75 mm borosilicate glass fluorometer cuvettes were used to collect samples

FIGURE 2-10. ANALYTICAL MANIFOLD FOR THE AUTOMATED ENZYMIC ASSAY OF ACETALDEHYDE.

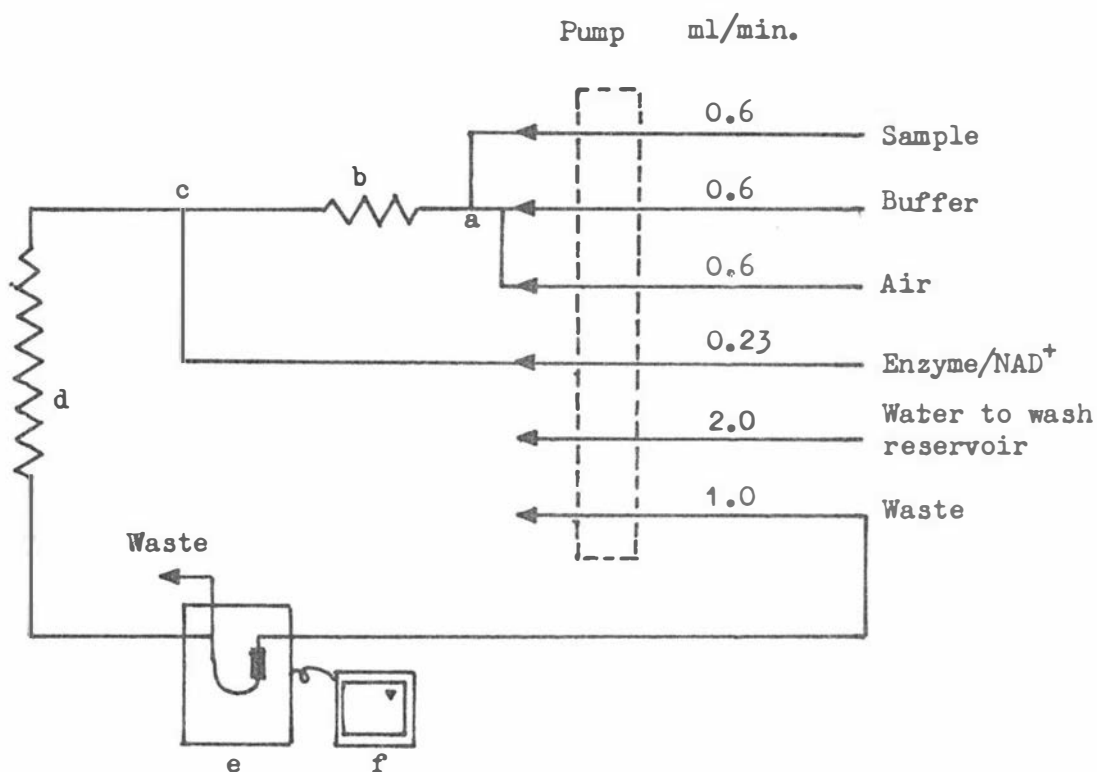

KEY

- a. H3 cactus.
- b. Single mixing coil at room temperature.
- c. D1 cactus.
- d. Two double mixing coils at room temperature.
- e. Turner (110) filter fluorometer. 1<sup>o</sup> filter=7-60, 2<sup>o</sup> filter=2A + 48. Flow cuvette volume = between 1 and 2 ml.
- f. Technicon chart recorder.

of this mixture from the open end of the tube. The pumping rates used were chosen to handle sample volumes of approximately 2 ml using 5 ml fluorometer cuvettes.

#### 2-4-2-1. Phasing of sample collection.

To collect the acetaldehyde samples as they reached the end of the gas/liquid separator outlet pumping tube, it was necessary to determine the length of time required for the sample to pass from a sample cup to this point. The transit time was estimated by timing a bubble from the sampler to coil (c) of Fig. 2-3 and from separator (g) of Fig. 2-3 to the sample outlet, with two seconds being added to allow for the passage time in the nitrogen stream. Sample collection was phased so that collection extended from five seconds before the estimated time of appearance of acetaldehyde in the outlet tube to five seconds after its estimated disappearance at the outlet. A sampling time of 1 min. was used, collection lasted for 70 seconds and the volume of buffer collected was about 4.5 ml. During the operation of the manifold, a stopwatch was used to time sample collection. After collection, each sample was covered to prevent loss of acetaldehyde by evaporation.

#### 2-4-2-2. Development of fluorescence.

Following the completion of sample collection, 0.5 ml of a freshly prepared solution containing  $\text{NAD}^+$  (1.5 mM) and sheep-liver aldehyde dehydrogenase (approximately 84 units<sup>1</sup>/ml) was added to each sample and the two solutions mixed by inversion. The concentrations used were similar to those in the diffusion assay which had been shown to give linear standard curves with acetaldehyde concentration ranges the same as those expected in the buffer-'distillate' solution. The tubes were sealed with parafilm and after incubation at room temperature for varying times the fluorescence of each tube was determined using a Turner (Model 430) spectrofluorometer fitted with a single position sample compartment (#430-011)<sup>2</sup>. Excitation and emission wavelengths used were 350 and 460 nm respectively. In initial experiments using this method, it was found that complete conversion of acetaldehyde in the sample to acetate was obtained within 15 - 20 min. at room

---

1. Units defined in Section 2-2.

2. G.K. Turner and Associates Catalogue No.

temperature with acetaldehyde samples in the range 1 - 10  $\mu\text{M}$ .

#### 2-4-2-3. Reproducibility.

In initial experiments to obtain a standard curve using the semi-automated procedure outlined above, the distillation temperature, gas flow-rate and sampling rate were fixed at 90°C, 440 ml/min. and 40/h. (2:1 sample:wash ratio) respectively and tap-water was used to cool the condenser coil. Using these conditions, sensitivity was satisfactory but reproducibility was poor, especially when standards were run in a random order. Subsequently it was found that using a sampling rate of 20/h. with a 1:2 sample:wash ratio improved reproducibility markedly. Satisfactory results are now always obtained if sampling begins after the temperature of the heating-bath, and nitrogen flow-rate are adjusted to defined values and the buffer is pumped through the system for at least five minutes.

The lowest standard used gave a fluorescence reading sufficiently high to allow use of the X100 range setting of the fluorometer and a sensitivity setting sufficiently low so that the noise level was <0.5% of the fluorescence reading of the high standard (10  $\mu\text{M}$ ). Fluorometer cuvettes always gave identical blank fluorescence readings and they could be re-used many times before giving erratic results due to differences in blank fluorescence.

#### 2-4-2-4. Characteristics of the distillation manifold.

When the distillation manifold was shown to operate satisfactorily in the desired acetaldehyde concentration range under the fixed conditions mentioned above, these conditions were varied in order to determine the optimum operating conditions for the semiautomated assay.

The effect of nitrogen flow-rate on acetaldehyde recovery.

Using a flowmeter capable of measuring the nitrogen flow-rate between 100 and 1,200 ml/min., duplicate 10  $\mu\text{M}$  acetaldehyde standards and blanks were taken through the assay procedure already described at four gas flow-rates. Tap-water was circulated through the jacket of the condenser coil and a constant water-bath temperature of 90°C was employed. From Fig. 2-11 it may be seen that the efficiency of transfer of acetaldehyde from sample to buffer, at constant temperature, increased with decreasing nitrogen flow-rate between 1,200 and 100 ml/min.

To obtain maximum sensitivity, the nitrogen flow-rate for subsequent assays was routinely set at a single value between 100 and 400 ml/min. The possibility of increasing sensitivity further by using even lower flow-rates was considered, but using the gas regulation equipment available, nitrogen flow was very irregular below about 100 ml/min.

#### Determination of optimum distillation temperature.

Duplicate 10  $\mu$ M acetaldehyde standards and blanks were taken through the assay procedure at six different heating-bath temperatures using a fixed nitrogen flow-rate of 130 ml/min. and tap-water to cool the condenser. Fig. 2-12 shows that the maximum efficiency of distillation under these conditions was reached at about 80°C. This result compared well with the results obtained when higher acetaldehyde standard concentrations were used in the spectrophotometric assay (see Fig. 2-9). Subsequent assays were performed with the temperature of the heating-bath set at 90°C so that any possible fluctuation in temperature less than  $\pm 10^\circ\text{C}$  would not affect the distillation efficiency significantly.

#### Condenser temperature.

Duncombe and Shaw (1966) had suggested refrigeration of the water entering the condenser coil water jacket as a means of increasing the recovery of aldehydes in their distillation apparatus. It was found however, that cooling of the condenser coil to 2°C increased the acetaldehyde recovery by only 6% compared with the use of tap-water flowing through the jacket at a temperature of approximately 17°C. Refrigeration was therefore considered unnecessary.

#### Efficiency of distillation.

Using established conditions of temperature and nitrogen flow-rate (90°C and 130 ml/min.) the efficiency of distillation compared to the direct addition of acetaldehyde to the reagent mix was determined. A standard curve was prepared by distillation of acetaldehyde standards using the semiautomated assay procedure and this was compared with a standard curve prepared by direct addition of the same standards to the reagent mix containing buffer,  $\text{NAD}^+$  and enzyme in the same proportions and total volume as used for the semiautomated method. The volume of the acetaldehyde standards used for the direct addition method were identical to the volumes sampled and distilled. The results indicated that the efficiency with which acetaldehyde was transferred from sample to buffer was  $46 \pm 3\%$ . This is considerably lower than that obtained

FIGURE 2-11. EFFECT OF NITROGEN FLOW-RATE ON RECOVERY OF ACETALDEHYDE.

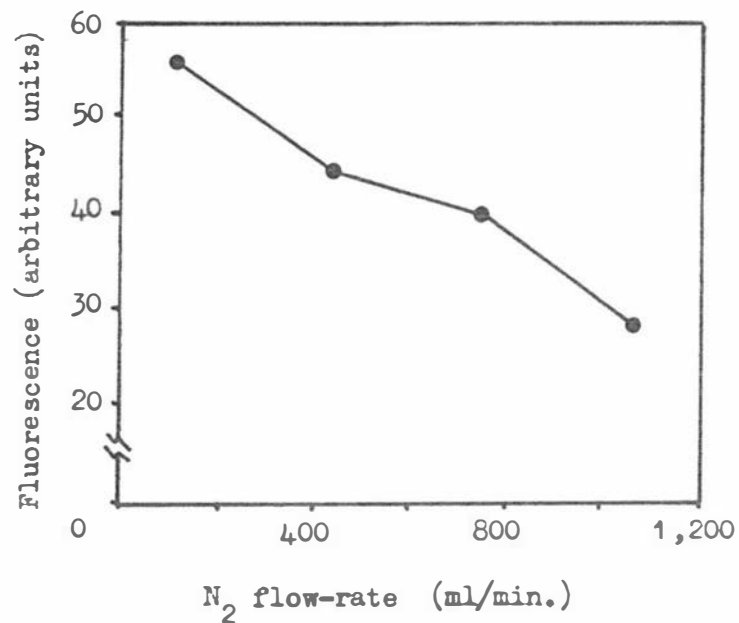
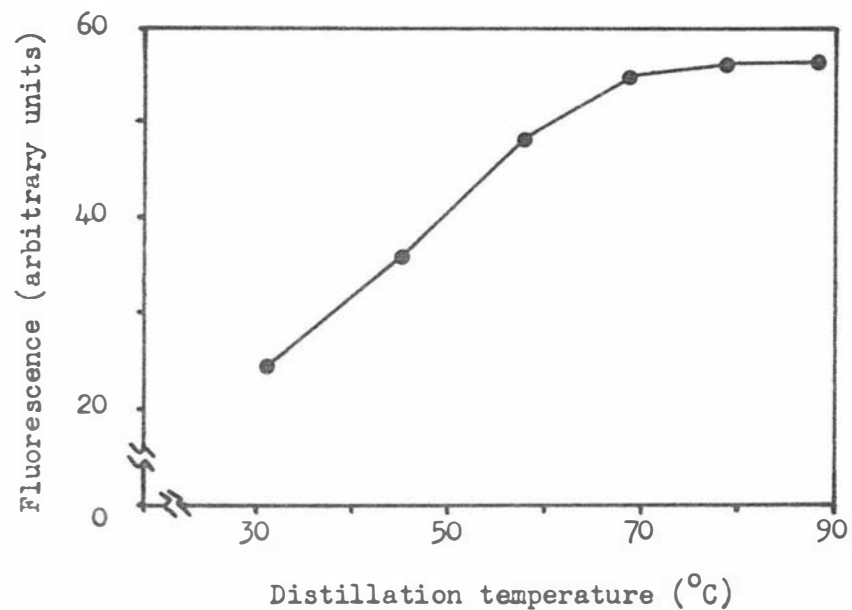

FIGURE 2-12. EFFECT OF DISTILLATION TEMPERATURE ON RECOVERY OF ACETALDEHYDE.



The data illustrated in the above two figures was obtained using the semiautomated enzymic acetaldehyde assay method. See Section 2-4-2-4 for experimental details. The points on both graphs represent the means of duplicate determinations.

using the spectrophotometric assay (see Section 2-3-2.) but may be due to the fact that there is an order of magnitude difference between the ranges of acetaldehyde concentration used for each determination.

#### Sampling rate.

An attempt to increase the sampling rate from 20/h. to 35/h., retaining the 1:2 sample:wash ratio, resulted in a 25% decrease in sensitivity without affecting other aspects of the assay.

#### 2-4-2-5. Standard curves.

The standard curve shown in Fig. 2-13 was produced using the semiautomated assay and by randomly sampling standards and blanks. It was found that the maximum error associated with a single measurement of acetaldehyde in the range 1 - 10  $\mu\text{M}$  is about  $\pm 0.25 \mu\text{M}$  allowing a minimum detectable level of about 0.25  $\mu\text{M}$ . The significance of levels below this could be determined by assaying the samples several times. For undefined reasons, the reproducibility of replicate samples or standards was found to be variable from day to day and Fig. 2-13 shows the maximum variation of replicate standards obtained.

The response of the assay system to concentrations of acetaldehyde up to 100  $\mu\text{M}$  is shown in Fig. 2-14 and illustrates the flexibility of both the distillation system and the analytical procedure.

#### 2-4-2-6. Specificity of the semiautomated assay.

Since sheep-liver cytosolic aldehyde dehydrogenase reacts with a number of aldehydes (Crow *et al.*, 1974) the method described is only specific for volatile aldehydes which will react with this enzyme. However, it is unlikely that human blood would contain any volatile aldehydes other than acetaldehyde which itself is usually found in measurable quantities only during the concurrent metabolism of ethanol.

Aqueous solutions of propionaldehyde could be assayed with the same efficiency as acetaldehyde and butyraldehyde at an 81% efficiency compared with acetaldehyde. Formaldehyde was found to react only very slowly with the enzyme when samples containing 1 - 10  $\mu\text{M}$  formaldehyde were carried through the normal assay procedure and stable fluorescence readings could not be obtained. No reaction was obtained with acetone at concentrations of up to 130  $\mu\text{M}$ .

No interference from ethanol was noted unless stock absolute ethanol from which aqueous solutions were prepared contained

FIGURE 2-13. ACETALDEHYDE STANDARD CURVE PRODUCED USING THE SEMIAUTOMATED ENZYMIC ASSAY METHOD.

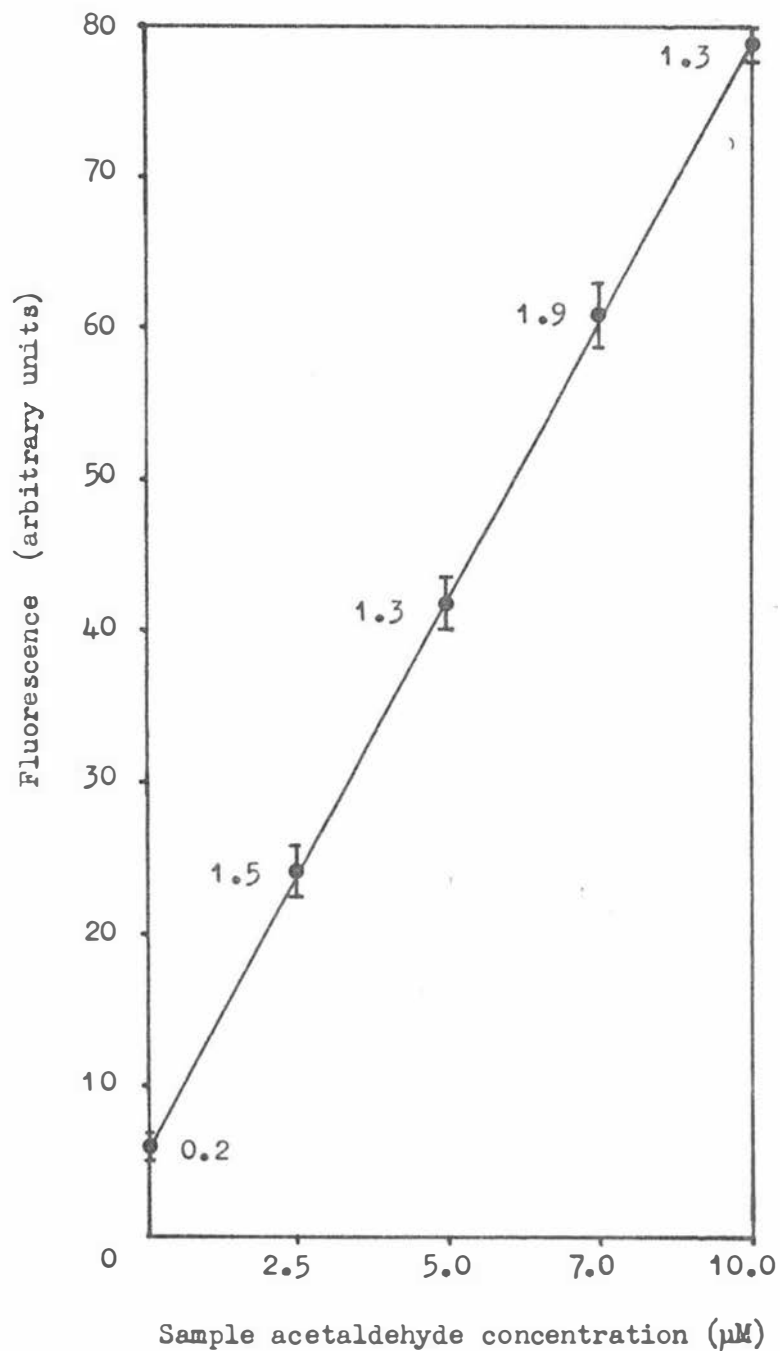

The mean and range of five determinations are represented for each concentration. The figures by each point represent one standard deviation.

FIGURE 2-14. ACETALDEHYDE STANDARD CURVE PRODUCED USING THE SEMIAUTOMATED ENZYMIC ASSAY METHOD.

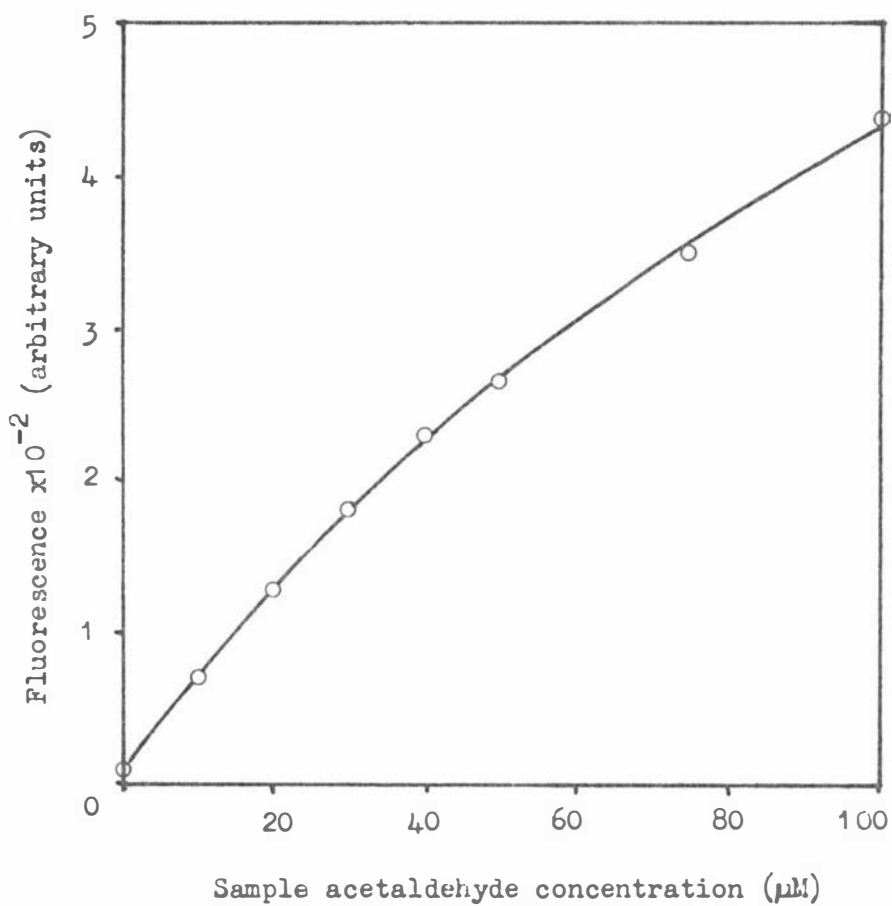

The points on the above curve represent single determinations.

contaminating acetaldehyde. This acetaldehyde level was always found to be extremely low and very high sample concentrations of ethanol had to be used to obtain appreciable interference (see Fig. 2-15). From Fig. 2-15 it is obvious that fluorescence readings of samples containing both ethanol and acetaldehyde may be corrected for the fluorescence due to contaminating acetaldehyde in the ethanol. Since sample ethanol concentrations used in this study were never higher than 40 mM, corrections of more than one or two fluorescence units were not necessary.

#### 2-4-2-7. Use of yeast aldehyde dehydrogenase with the semiautomated assay.

While the sheep-liver aldehyde dehydrogenase gave good results in the semiautomated assay it was not commercially available and considerable time was required to prepare it for use in the assay. Although yeast aldehyde dehydrogenase was commercially available it was initially decided that it would not be suitable because of its low affinity for acetaldehyde and the possibility that it would not quantitatively oxidize acetaldehyde to acetate (Lundquist, 1958). This latter assumption was found to be incorrect and the yeast enzyme was successfully used to replace the sheep-liver enzyme in the diffusion assay (Crow, 1976, personal communication). When this knowledge became available the replacement of the sheep-liver enzyme with the yeast enzyme in the semiautomated assay was considered worthwhile.

The yeast enzyme was found to be suitable for use in this assay if 100 mM pyrophosphate buffer pH 8.0 was used to replace the 15 mM pyrophosphate buffer pH 9.3, and  $K^+$  (700 mM) and 2-mercaptoethanol (0.1% v/v) were added to the enzyme/ $NAD^+$  reagent. The choice of these reagent concentrations was based on the acetaldehyde assay using yeast aldehyde dehydrogenase as described by Lundquist (1974). The original buffer used by Lundquist was Tris. but this has been found to bind aldehydes (Crow, 1976, Personal communication). Potassium ions were necessary since aldehyde dehydrogenase from yeast is a  $K^+$ -activated enzyme.

An enzyme concentration found to give satisfactory standard curves using an incubation time of about 20 min. was 0.05 units<sup>1</sup>/0.5 ml of

---

1. Enzyme units as defined by the Sigma Chemical Co. i.e. 1 unit will oxidize 1.0  $\mu$ mole of acetaldehyde to acetic acid per minute at pH 8.0 and 25°C in the presence of  $NAD^+$ ,  $K^+$  and 2-mercaptoethanol.

FIGURE 2-15. INTERFERENCE OF ETHANOL WITH THE SEMI-AUTOMATED ENZYMIC ASSAY.

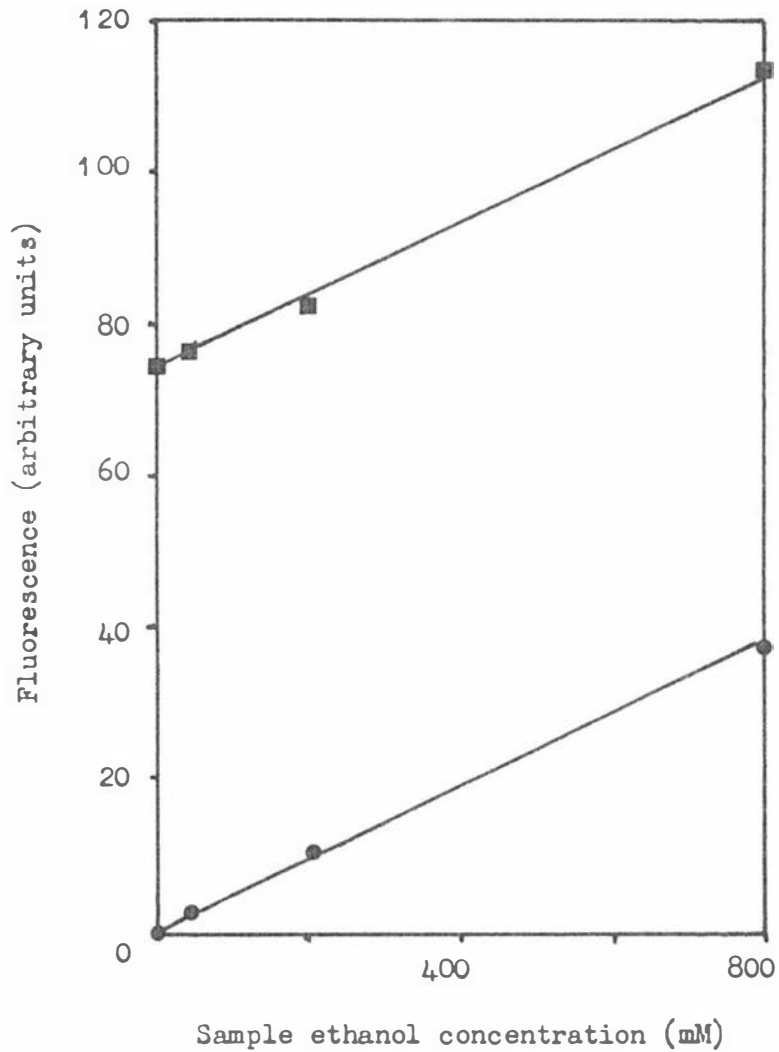

Samples containing ethanol only (●) and ethanol plus 10  $\mu\text{M}$  acetaldehyde (■) were assayed using the semiautomated enzymic acetaldehyde assay method. The points in the above graph represent single determinations.

enzyme/ $\text{NAD}^+$ / $\text{K}^+$  mixture. The effect of ethanol on the assay, using the new enzyme was found to be the same as for the sheep enzyme.

The semiautomated assay method was used a great deal for assay of acetaldehyde in blood samples after blood recovery experiments had been performed (see Section 2-4-4). Performance of the assay was satisfactory at all times but the need for manual sample collection and timing became a logistics problem when large numbers of samples were analyzed per run. Accordingly, with the knowledge that the distillation manifold was working well, another attempt was made to fully automate the assay procedure.

### 2-4-3. Fully automated acetaldehyde assay.

#### 2-4-3-1. The manifold.

The same distillation manifold used for the semiautomated assay was set up in conjunction with an analytical manifold shown in Fig. 2-16. An automated-chemistry adapter (# 30-035)<sup>1</sup> was used in conjunction with a Turner (Model 430) spectrofluorometer and an RDK potentiometric chart recorder was used to monitor fluorescence peaks. Fluorescence was determined using excitation and emission wavelengths of 350 and 460 nm respectively.

With a long wash-cycle, continuous pumping of enzyme would have resulted in two thirds of the enzyme solution being wasted. To avoid this, an extra sampling probe was attached to the existing moving arm of the autoanalyzer sampler by an extension arm. This extra probe dipped into a container of enzyme solution and aspirated it only when the sample was being pumped. A separate wash reservoir was constructed for the enzyme sampler. The transmission tubing carrying the enzyme solution was adjusted in length so that the entry of enzyme into the H3 cactus coincided with the entry of acetaldehyde from the sample. The enzyme solution was kept on ice throughout the operation period of the manifold.

#### 2-4-3-2. Operation of the manifold.

Initial attempts to use the sheep-liver enzyme in the fully automated system were unsuccessful. Although sensitivity was excellent and a good baseline was present, sensitivity dropped markedly with time

---

1. G.K. Turner and Associates Catalogue No.

FIGURE 2-16. ANALYTICAL MANIFOLD FOR THE FULLY AUTOMATED ENZYMIC ACETALDEHYDE ASSAY.

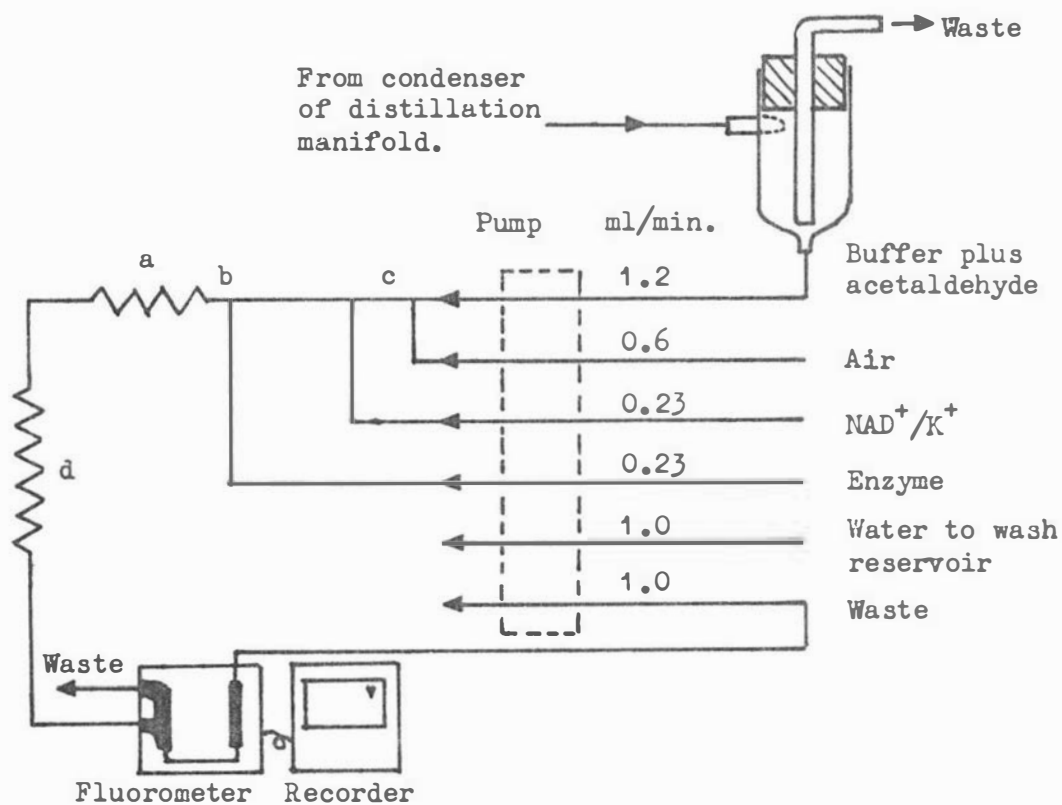

KEY

- a. Single mixing coil.
- b. AO junction.
- c. H3 cactus.
- d. Delay coil (40 feet, 1.6 mm I.D., thermostated at 37°C).

over a 2 - 3h. running period and it was thought that this may be due to loss of enzyme activity in a dilute solution. Using the yeast enzyme overcame this problem.

The final method involved the use of 100 mM pyrophosphate buffer pH 8.0, 1.5 mM  $\text{NAD}^+$  containing 700 mM KCl, and the enzyme solution was prepared by dissolving crystalline yeast aldehyde dehydrogenase in pyrophosphate buffer containing 700 mM KCl plus 0.1% v/v 2-mercaptoethanol. An enzyme concentration of 0.4 units<sup>1</sup>/ml was initially used to produce linear standard curves but it was later found that 0.1 units/ml was sufficient for the successful operation of the assay.

The lag time from initiation of sampling to recorder response was approximately 15 min.

One peculiarity of this system was noted in the production of small peaks above the baseline when blanks were being run. This was due to the intermittent sampling of the enzyme; the enzyme itself fluoresces slightly and a peak of fluorescence will occur for each sample whether acetaldehyde is present or not. These peaks were consistent in height and were used as an artificial baseline.

Standard curves produced with the fully automated method were found to be almost identical to those produced using the semiautomated system with respect to fluorescence level and sample reproducibility. A typical chart tracing of acetaldehyde standards is shown in Fig. 2-17.

Up to 60 samples per run have been assayed using the fully automated procedure and it was found more convenient and just as economical to use with small sample numbers as the semiautomated method; the fully automated method actually requiring less enzyme per sample.

#### 2-4-4. Recovery of acetaldehyde from human blood.

It was envisaged that blood samples would be assayed after treatment with an equal volume of 1M perchloric acid (PCA) and centrifugation to obtain a protein-free supernatant which could be distilled. This method of treatment had been used previously in this laboratory and was used again to determine the recovery of acetaldehyde from blood using the new assay procedure.

##### 2-4-4-1. Methods.

Concentrated acetaldehyde solutions were added to blood samples so that the sample volume was increased by no more than 1%.

---

1. Units as defined by the Sigma Chemical Co.

FIGURE 2-17. CHART RECORDING OF ACETALDEHYDE STANDARDS ASSAYED USING THE FULLY AUTOMATED ENZYMIC ASSAY SYSTEM.

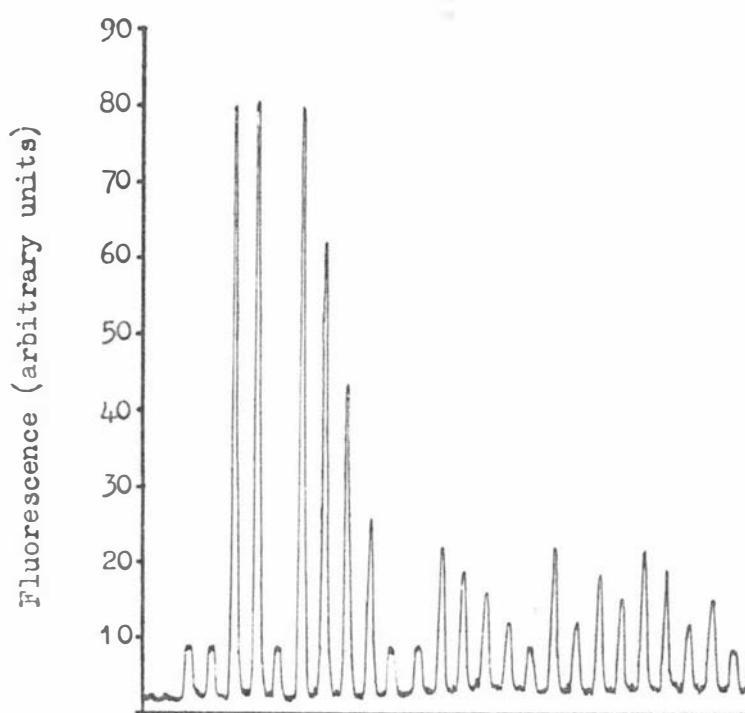

The peaks in this diagram represent (from left to right) aqueous acetaldehyde standards having the following concentrations ( $\mu\text{M}$ ) :- 0.0, 0.0, 10.0, 10.0, 0.0, 10.0, 7.5, 5.0, 2.5, 0.0, 0.0, 2.0, 1.5, 1.0, 0.5, 0.0, 2.0, 0.5, 1.5, 1.0, 2.0, 1.5, 0.5, 1.0, and 0.0.

Sampling rate = 40/h. Sample:wash ratio = 1:2.

Deproteinization was carried out with an equal volume of ice-cold 1M PCA after thorough mixing of the acetaldehyde and blood. Protein-free supernatants obtained by centrifugation were then assayed without further treatment. Aqueous standards were prepared in the same way except that the PCA was replaced by distilled water.

Blood used for these experiments was either fresh heparinized human venous blood or outdated blood bank blood, no difference being found between the two with respect to recovery of acetaldehyde.

#### 2-4-4-2. Results.

Table 2-1 shows that recovery of acetaldehyde added to blood is close to 100%, compared with aqueous standards. Recovery of acetaldehyde from blood at concentrations up to 200  $\mu$ M was never less than 95%. However, good recoveries could be achieved only if the blood was chilled (0 - 4°C) before acetaldehyde addition. It is well known that acetaldehyde added to blood at higher temperatures rapidly disappears and that cooling of the blood samples inhibits this removal (Duritz and Truitt, 1964; Stotz, 1943). A study of this effect is the subject of section 4 of this thesis.

No correction was made for the solid content of blood when calculating recoveries. Since identical recoveries were obtained from plasma samples, and deproteinized whole blood supernatant samples to which acetaldehyde was added after deproteinization, it seemed that no correction was necessary. The excellent recoveries further suggest that the efficiency of acetaldehyde distillation from PCA supernatants is the same as that from aqueous solutions. This was a significant finding since it meant that processing of the blood samples could be kept to a minimum.

Acetaldehyde in concentrations of up to 200  $\mu$ M was found to be stable in deproteinized blood or plasma supernatants for at least 24h. if these were kept in sealed containers at 4°C

With the same methods used to determine acetaldehyde recovery from blood, acetaldehyde concentrations in urine were also determined. The results showed that recovery with respect to aqueous standards was only 43% when the samples were assayed immediately after processing and only 8% when the samples were assayed after storage at 4°C for 24h. For reasons not defined, it was obvious that the method was not suitable for urine acetaldehyde analysis.

TABLE 2-1.

## RECOVERY OF ACETALDEHYDE ADDED TO WHOLE BLOOD

---

Acetaldehyde added to whole blood.  ( $\mu$ moles/l)	Acetaldehyde recovered.  ( $\mu$ moles/l)	
	mean <sup>a</sup>	range
0.0	0.0 <sup>b</sup>	-
4.0	4.0	-
12.0	12.0	11.8 - 12.3
20.0	19.8	19.0 - 20.4

---

a n=4 for each acetaldehyde concentration.

b No significant levels of acetaldehyde were found in the blank blood samples used for this experiment.

The recovery of acetaldehyde from blood was determined as described in Section 2-4-4 using the semiautomated enzymic assay method.

#### 2-4-5. Assay of blood samples containing ethanol.

Truitt (1970) has noted that 'bound' acetaldehyde is released from human red blood cells in the presence of ethanol and a deproteinizing agent, and Sippel (1972,1973) has stated that acetaldehyde may be formed from ethanol in supernatants obtained from rat blood treated with PCA. This assay, being specifically designed for the assay of acetaldehyde in blood which would also contain ethanol, would have been seriously affected if either of these two effects did occur. An experiment was performed in which blood, containing ethanol in the range commonly found in human blood (10 - 40 mM) was deproteinized with PCA in the manner described for the recovery experiments. When the protein-free supernatants were assayed, variable quantities of acetaldehyde, up to about 40  $\mu\text{M}$ , were measured. The variability and level of the interference by ethanol was too large for the assay to be used accurately for ethanol-containing blood samples. This problem has been studied further and the results are presented in Section 3 of this thesis.

#### 2-5. DISCUSSION.

The use of distillation in place of diffusion has overcome all the major problems associated with the operation of a fluorometer at high sensitivity settings. In addition, long incubation times have been eliminated as well as time-consuming mixing procedures. Accordingly, by using either the semi- or fully automated assay systems, large numbers of samples may be processed in each run.

The sensitivity of these methods (minimum detectable level  $< 0.25 \mu\text{M}$ ) is a considerable improvement on previously published enzymic methods for acetaldehyde determinations (Lundquist, 1958; Bernt and Bergmeyer, 1974; Tottmar and Marchner, 1976). The most sensitive published enzymic method (Lundquist, 1958) permits detection of acetaldehyde at a minimum level of 0.1  $\mu\text{g/ml}$  (2.3  $\mu\text{M}$ ) in plasma. The method used by Tottmar and Marchner, based on a fluorometric measurement of NADH produced from the reaction of acetaldehyde with  $\text{NAD}^+$  and the rat-liver mitochondrial aldehyde dehydrogenase, is reported to be capable of detecting a minimum acetaldehyde level of 6  $\mu\text{M}$  in rat blood (Pettersson and Kiessling, 1976).

There is a lack of published data concerning the maximum sensitivity obtained with many of the currently used gas chromatographic procedures for acetaldehyde estimation but the sensitivity of the automated enzymic methods is almost the same as one gas chromatographic method used by

Cohen and MacNamee (1976) which has been reported to be capable of measuring acetaldehyde at levels down to  $0.28 \mu\text{M}$  in undiluted rat blood plasma samples.

The distillation step employed in the automated assays restricts estimations to volatiles only and so the procedures are more specific than methods involving the direct addition of biological extracts to reaction mixtures (Lundquist, 1958; Bernt and Bergmeyer, 1974; Tottmar and Marchner, 1976). The latter methods require that the protein precipitant be neutralized prior to mixing of the sample with the enzyme; this step has been eliminated in the new methods now developed.

While this work was being completed, a new chemical method for the analysis of acetaldehyde based on the reaction of diaminobenzoic acid with acetaldehyde appeared in the literature (Beckmann, 1976). This method appears to overcome the main problems associated with previous chemical methods (Stotz, 1943; Burbridge *et al*, 1950) i.e. lack of specificity and sensitivity. The method is stated to be capable of detecting a minimum blood acetaldehyde concentration of  $2.5 \mu\text{M}$  in only  $20 \mu\text{l}$  of blood and is specific for aldehydes with an alpha-methylene group (Velluz *et al*, 1948). Since acetaldehyde is the only aldehyde likely to be found in human blood that fulfils this criterion it would appear that this assay may be an improvement on all previous methods. If this is not the case, the assay could no doubt be adapted for use in conjunction with the distillation system described in this study to increase the specificity further.

One disadvantage of the automated assays described here is the relatively large sample size required. To obtain enough deproteinized blood supernatant for assay when a 1:1 dilution with the protein precipitant is used, at least 1.5 ml of blood is required or about 3.5 ml of blood if plasma analysis is used. The new chemical method appears to eliminate this need for larger samples and could enable many more determinations to be carried out on blood from one individual.

## SECTION 3

FORMATION OF ACETALDEHYDE IN BLOOD SAMPLES CONTAINING ETHANOL  
DURING DEPROTEINIZATION.

3-1. INTRODUCTION.

The measurement of high levels of acetaldehyde when ethanol-containing blood was deproteinized and assayed (Section 2-4-5) was not unexpected. It has been recognized by various authors that when acetaldehyde-free blood samples containing ethanol are deproteinized, acetaldehyde can be measured in the protein-free extracts (MacLeod, 1950; Truitt, 1970; Korsten et al, 1975; Eriksson et al, 1975). This has been, and remains a major problem associated with studies on acetaldehyde metabolism in human subjects.

The mechanism by which the acetaldehyde production occurs is unknown although different explanations have been put forward to explain its formation. MacLeod (1950) found that large amounts of acetaldehyde were formed in ethanol-containing blood samples deproteinized with tungstic acid. This did not occur with plasma and it was suggested that the acetaldehyde formation might be '...connected with some alteration in the oxyhemoglobin at the time of denaturation...'. Truitt (1970) observed the same phenomenon when either a  $Zn(SO_4) - Ba(OH)_2$  mixture or tungstic acid was used to deproteinize whole blood containing ethanol. Evidence was presented to support the idea that the acetaldehyde was not formed directly from the ethanol but was 'bound' acetaldehyde released from some macromolecule by the presence of ethanol and the deproteinizing agent. Sippel (1972), however, considered that the acetaldehyde was formed directly from ethanol during the incubation of PCA supernatants of whole rat blood and liver, while being prepared for gas chromatographic analysis. Auto-oxidation of ascorbic acid with the formation of a semidehydroascorbate peroxy radical capable of reacting with ethanol to form acetaldehyde was postulated as the reaction mechanism (Sippel, 1973). Thiourea was found to inhibit this reaction completely in deproteinized rat liver supernatants and this compound has been used by various workers in an attempt to inhibit the reaction in both rat (Lindros et al, 1975; Eriksson et al, 1975; Collins et al, 1976) and human blood (Kesäniemi, 1974;

Korsten et al, 1975; Eriksson et al, 1975). Thiourea was used as a free-radical acceptor to break a radical chain reaction believed to be responsible for the acetaldehyde formation (Sippel, 1972).

Because of the need to apply relatively large corrections for the acetaldehyde artefact in deproteinized blood samples it was decided to examine in more detail, quantitative and qualitative aspects of its production specifically in human venous blood. By gaining more information on the mechanisms involved, it was considered that it might be possible to eliminate the artefact altogether or at least decrease it to a low and consistent level to permit accurate corrections to be made.

The only detailed investigations of this problem, with human blood (Truitt, 1970; Eriksson et al, 1975), have relied on gas chromatographic assays of acetaldehyde in head-space gas equilibrated with liquid samples. Such methods involve relatively long incubation periods at high temperatures (60 - 65°C) during which acetaldehyde could potentially be produced from ethanol. It was therefore considered essential that some of the results obtained using these methods be checked with a different analytical method. The enzymic assays described in Section 2 were considered ideal for this purpose.

Barker (1941) and Stotz (1943) have reported that very large amounts of acetaldehyde (up to 2,000  $\mu\text{M}$ ) can be formed from whole human blood treated with a  $\text{CuSO}_4 - \text{Ca}(\text{OH})_2$  reagent. However, this reaction was found to occur when ethanol was not present in the blood. From the present study, no acetaldehyde was produced in blank blood samples when they were deproteinized with PCA and it was considered unnecessary, for the purposes of the present aims, to examine that reaction further.

Production of acetaldehyde from ethanol in blood which has not been deproteinized has also been observed (Truitt, 1970; Machata and Prokop, 1971; Lüben et al, 1972; Eriksson et al, 1975; Crow, 1975) and has been discussed by Crow (1975). Study of this phenomenon was not considered worthwhile either, at least in relation to the assay of acetaldehyde in blood because in this study all samples were immediately deproteinized in order to avoid acetaldehyde losses.

## 3-2. METHODS.

### 3-2-1. Sample preparation.

All human blood samples used were freshly drawn from an antecubital vein and heparinized. Ox blood was obtained fresh from a local freezing works and oxalated. Whole blood or plasma samples containing added

ethanol were deproteinized with either one volume of 1M PCA or with nine volumes of 0.6M PCA to obtain 50% and 10% dilutions respectively. These two dilutions were chosen because the 50% dilution has been routinely used in this laboratory for the preparation of blood samples prior to estimation of ethanol, acetaldehyde, lactate and pyruvate, and the 10% dilution has been used for some recent work on acetaldehyde metabolism involving the assay of acetaldehyde in human blood (Korsten *et al*, 1975).

Concentrated ethanol standards were added to the blood or plasma samples to obtain the desired ethanol concentrations (0 - 40 mM) without increasing the volume by more than 1%.

Unless otherwise stated, deproteinization was carried out with ice-cold PCA solutions immediately after mixing blood with the ethanol.

With one exception which is noted in the Results Section, all experiments were performed with blood kept at room temperature.

Clear, protein-free supernatants were obtained by centrifugation of samples at 4°C and the acetaldehyde present in these supernatants was determined by the semiautomated assay described in Section 2-4-2 using sheep-liver aldehyde dehydrogenase.

Samples were kept sealed at 4°C until the assays were carried out.

In experiments where thiourea was used as a possible inhibitor of acetaldehyde formation, it was mixed with the PCA solution before deproteinization.

### 3-2-2. Controls.

For all assays, aqueous solutions containing ethanol only, and PCA mixed with ethanol, at concentrations equivalent to the deproteinized blood supernatants, were assayed with the other samples.

### 3-2-3. Blanks.

All blood acetaldehyde concentrations were also corrected for acetaldehyde present in blank blood samples to which no ethanol had been added. This level was  $1.0 \pm 0.2 \mu\text{M}$  (mean and S.D.) in blood samples diluted 50% but was undetectable in blood samples diluted to 10%. The minimum detectable level at this latter dilution was about 2  $\mu\text{M}$ .

### 3-2-4. Standards.

Acetaldehyde standards were prepared in aqueous solution from redistilled acetaldehyde and diluted in the same way as the blood samples.

### 3-3. RESULTS.

#### 3-3-1. Acetaldehyde production in controls.

Aqueous ethanol solutions diluted to 10% with PCA contained no detectable acetaldehyde, unless the ethanol concentrations used were greater than 100 mM. However, for controls prepared by a 50% dilution with PCA, very small amounts of acetaldehyde could be assayed, of the order of 0.5  $\mu$ M and 1.0  $\mu$ M acetaldehyde from 20 mM and 40 mM solutions of ethanol respectively. Reproducible values for these acetaldehyde levels were obtained if the same absolute ethanol stock solution was used and these values did not change with storage of the control samples for up to 48h. at 4°C. The same level of acetaldehyde could be produced by replacing PCA with a non-oxidizing acid, e.g. hydrochloric acid (1M), which suggested that the very small amount of acetaldehyde being measured resulted from the hydrolysis of an impurity in the absolute ethanol, such as a vinyl ether.

In controls containing ethanol alone, small amounts of acetaldehyde were also detected, but only if the 50% dilution was used. This interference has been mentioned in Section 2-4-2-6. Since the acetaldehyde produced in control samples was always consistent and directly proportional to the ethanol concentration, an accurate correction was possible. The validity of such a correction can be deduced from Fig. 3-1. All quoted acetaldehyde concentrations in this section have been corrected for control levels of acetaldehyde, if the substance was present.

#### 3-3-2. Acetaldehyde production in whole blood and plasma using a 50% dilution.

Typical curves obtained by deproteinizing blood samples containing varying amounts of ethanol are shown in Fig. 3-2. The results in each curve were obtained using blood from a different individual.

For this experiment, blood samples were incubated with ethanol at 37°C before deproteinization. However, it was found that the same levels of acetaldehyde were produced if the blood was kept at room temperature before deproteinization.

The variations between individuals is probably not significant since similar variations were observed in duplicate experiments on blood from the same individual (see Table 3-1). By repeating assays on samples stored at 4°C for 24h., it was shown that the average level of acetaldehyde in the protein-free supernatants remained constant (Table 3-1).

The corresponding results for plasma are shown in Fig. 3-3 where

FIGURE 3-1. PRODUCTION OF ACETALDEHYDE IN CONTROL SAMPLES.

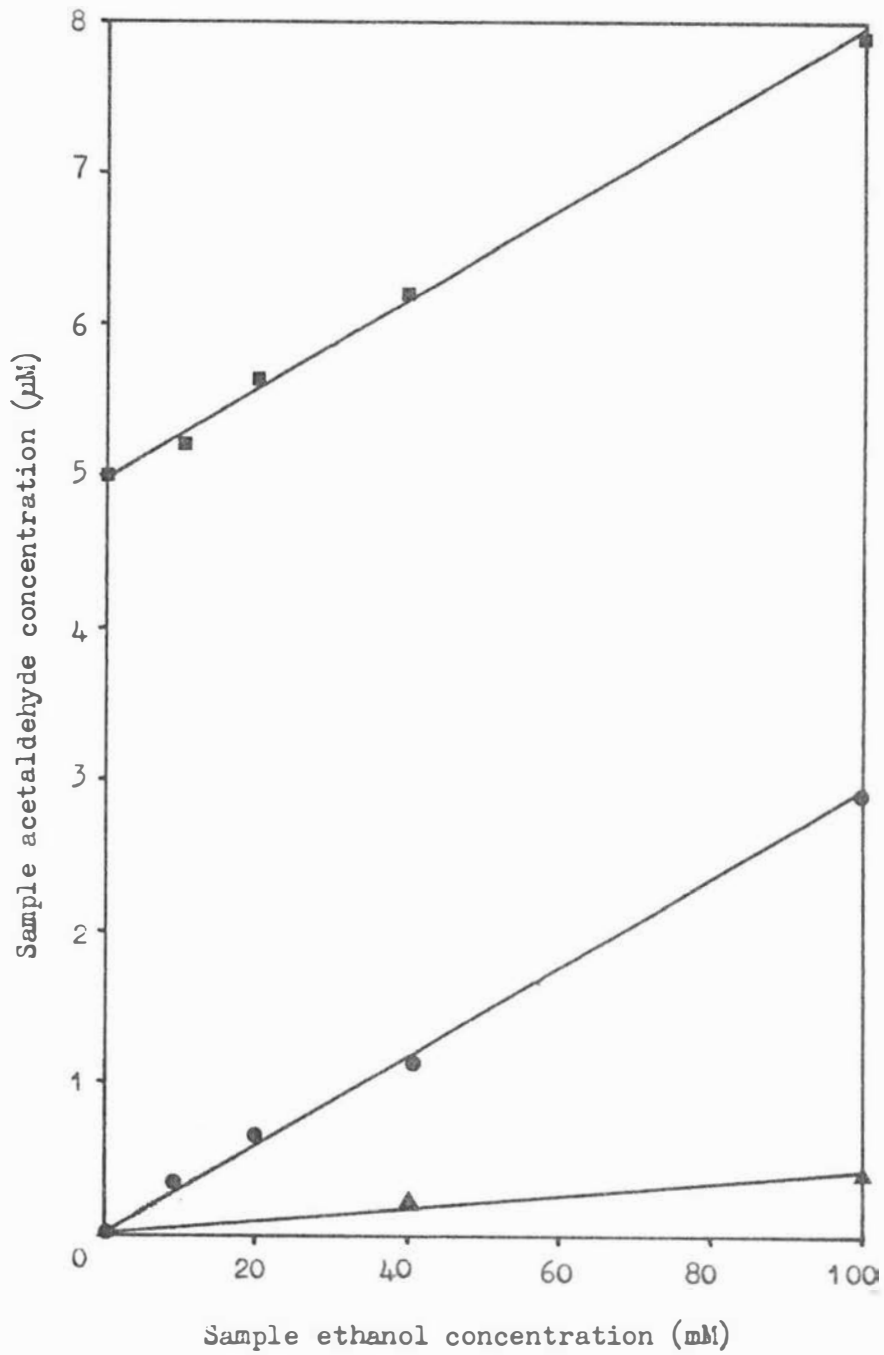

Aqueous solutions containing ethanol only (▲), ethanol in 0.5M PCA (●) and ethanol in 0.5M PCA plus 5 µM acetaldehyde (■) were assayed using the semiautomated enzymic assay method described in Section 2-4-2. The points in the above figure represent single determinations.

FIGURE 3-2. PRODUCTION OF ACETALDEHYDE IN WHOLE BLOOD DEPROTEINIZED IN THE PRESENCE OF ETHANOL BY A 50% DILUTION WITH 1M PCA.

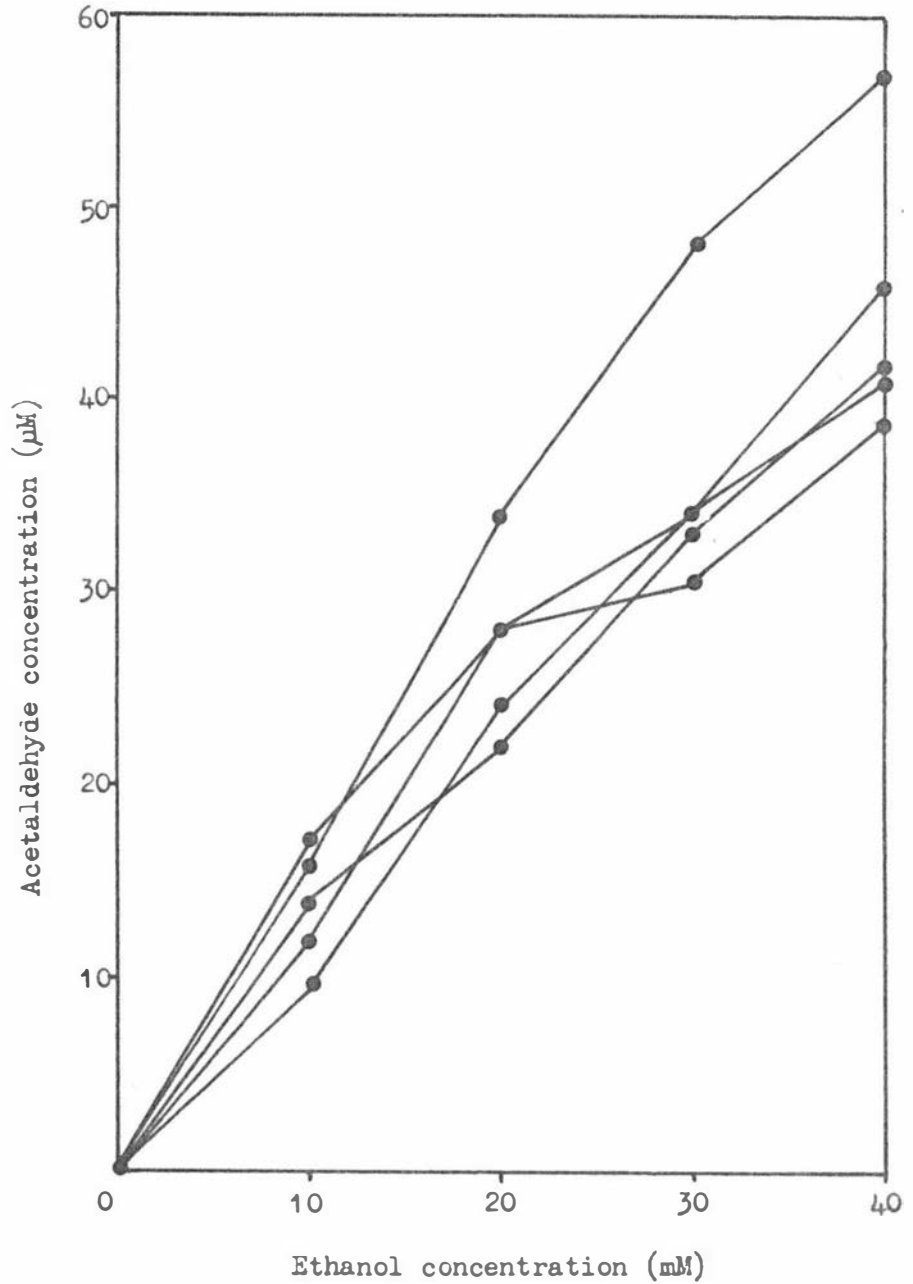

Each point in the above figure represents a single determination and concentrations of ethanol and acetaldehyde refer to undiluted blood.

TABLE 3-1.

ACETALDEHYDE PRODUCTION IN WHOLE BLOOD DEPROTEINIZED IN THE PRESENCE OF ETHANOL USING A 50% DILUTION WITH PCA.

	Blood ethanol concentration (mM)	
	20	40
	Acetaldehyde produced ( $\mu$ moles/l of blood) <sup>a</sup>	
(i) Data from five different individuals.	27 $\pm$ 5	44 $\pm$ 5
(ii) Data from five replicate blood samples from one individual.	27 $\pm$ 2	41 $\pm$ 9
(iii) Samples from (ii) assayed after storage at 4°C for 24h.	27 $\pm$ 3	40 $\pm$ 5

a. Mean  $\pm$  S.D. (n=5).

TABLE 3-2.

THE EFFECT OF THIOUREA ON ACETALDEHYDE PRODUCTION.

Blood ethanol concentration (mM)	Acetaldehyde formed ( $\mu$ moles/ l blood) <sup>a</sup>	
	+ Thiourea	- Thiourea
0	0	0
10	14 $\pm$ 2	14 $\pm$ 3
20	26 $\pm$ 9	27 $\pm$ 5
30	36 $\pm$ 8	35 $\pm$ 7
40	49 $\pm$ 14	44 $\pm$ 5

a. Mean  $\pm$  S.D. (n=5)

The blood used for this experiment was from one individual.

FIGURE 3-3. PRODUCTION OF ACETALDEHYDE IN PLASMA DEPROTEINIZED IN THE PRESENCE OF ETHANOL BY A 50% DILUTION WITH 1M PCA.

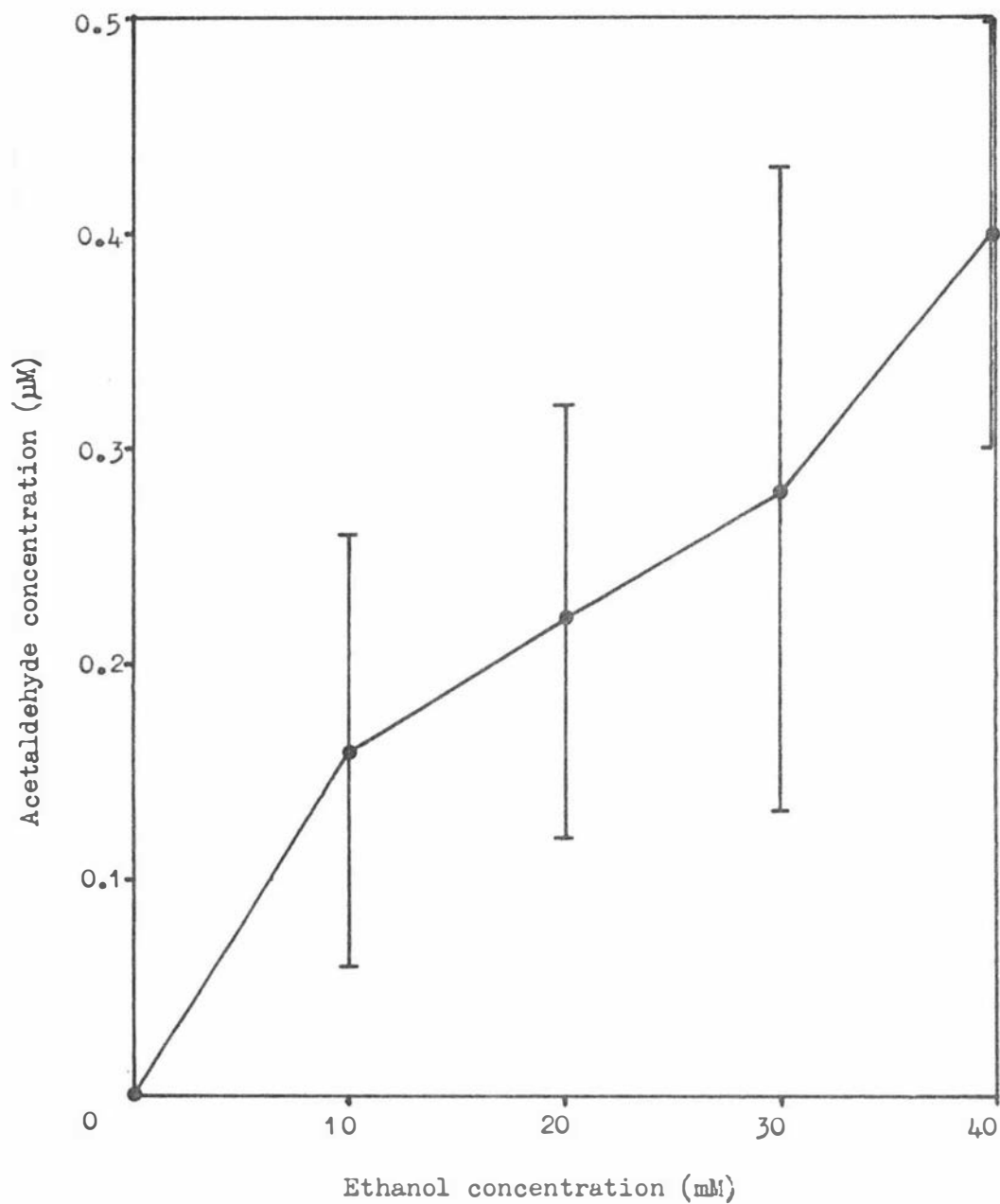

Each point in the above figure represents the mean of five determinations and the bars represent two standard deviations. The ethanol and acetaldehyde concentrations refer to undiluted plasma.

the means of five separate estimations have been plotted for each plasma ethanol concentration. Very low values were obtained after corrections had been made for the control acetaldehyde levels. Plasma samples from five different individuals were used.

The large variations and non-linearity of the acetaldehyde production in whole blood samples show that the use of a correction curve would be impractical. A recent study of blood acetaldehyde levels in humans metabolizing ethanol suggests that at a blood ethanol level of 40 mM, venous blood acetaldehyde levels are about 30 - 45  $\mu\text{M}$  (Korsten et al, 1975). From Fig. 3-2 it is clear that the necessary correction for the presence of artefact acetaldehyde at this ethanol level would be higher than the actual level of acetaldehyde in the blood before deproteinization. Therefore, irreproducibility of the artefact would result in a large percentage error in corrected acetaldehyde values.

The use of plasma analysis could overcome this problem, since acetaldehyde production in plasma is negligible compared to that observed for whole blood. It was found however, that no more than 70% of acetaldehyde added to blood could be recovered when plasma was used for analysis. It was assumed that this was due to the metabolism of acetaldehyde in the blood during the time required to separate the plasma and red cells. These findings were studied further and the results are given in Section 4.

### 3-3-3. Effect of thiourea on acetaldehyde production using a 50% dilution of blood.

Using a 50% dilution of blood with 1M PCA containing 50 mM thiourea (a concentration reported to inhibit the so-called 'non-enzymic' ethanol oxidation in PCA supernatants of rat liver (Sippel, 1972)), it was found that the thiourea had no inhibitory effect on the production of acetaldehyde from ethanol during deproteinization of human blood (Table 3-2). Thiourea did not increase the reproducibility of the acetaldehyde production, and it was decided to test the effect of a higher dilution of the blood since Korsten et al. (1975) had reported lower levels of acetaldehyde production when blood was diluted 1:9 with 0.6N PCA.

### 3-3-4. Effect of blood dilution on acetaldehyde production.

The results in Table 3-3 show that the level of acetaldehyde obtained using a 10% dilution of blood is approximately 25% of that obtained with a 50% dilution of blood. The variation in replicate

TABLE 3-3.

## THE EFFECT OF BLOOD DILUTION ON ACETALDEHYDE PRODUCTION.

Blood ethanol concentration (mM)	Acetaldehyde formed ( $\mu$ moles/l blood) <sup>a</sup>	
	10% dilution	50% dilution
0	0	0
20	6 $\pm$ 1	27 $\pm$ 2
40	10 $\pm$ 1	41 $\pm$ 7

a. Means  $\pm$  S.D. (n=5)

The blood used for this experiment was from one individual.

TABLE 3-4.

## INTERINDIVIDUAL VARIATION IN THE PRODUCTION OF ACETALDEHYDE FROM ETHANOL IN BLOOD WHEN A 10% DILUTION WAS EMPLOYED.

Blood ethanol concentration (mM)	Acetaldehyde produced ( $\mu$ moles/l blood)		
	mean <sup>a</sup>	range	S.D.
10	3.9	2-6	1.7
20	7.3 (6)	5-11 (5-7)	1.9
30	9.7	7-15	2.4
40	11.6 (10)	9-18 (9-11)	2.9

a. n=10.

The figures in brackets are corresponding figures for one individual (n=5).

samples was also lower with the higher dilution. The same results were obtained whether the blood was added to the PCA containing ethanol or the PCA was added to the blood containing ethanol. A typical 'correction curve' constructed using the 10% blood dilution is shown in Fig. 3-4. The inter-individual variations in acetaldehyde production with this dilution are given in Table 3-4 and indicate that these are greater than intra-individual variations, in contrast to the results obtained for 50% blood dilutions.

Although a linear correction curve was still not obtained using this method, it is clear that by subtracting lower and more consistent acetaldehyde levels, a more accurate correction can be made using the correction curve prepared employing the 10% dilution of blood.

#### 3-3-5. Effect of thiourea on acetaldehyde production using a 10% dilution of blood.

Using 25 or 50 mM thiourea in 0.6M PCA to deproteinize blood samples containing added ethanol, it was found that acetaldehyde production was decreased markedly from about 10  $\mu$ moles/l of blood at the 40 mM ethanol level to about 4  $\mu$ moles/l. However, it was also found that the use of the above conditions for deproteinization resulted in a low recovery of acetaldehyde added to blood. Using 25 mM thiourea, acetaldehyde recovery from blood decreased by 49% in relation to recovery from blood deproteinized with PCA only. This occurred even though thiourea in the above concentrations was not found to decrease acetaldehyde recovery from pure aqueous solutions treated with PCA. It was considered, therefore, that thiourea was not useful when the present methods were used to prepare blood samples for acetaldehyde assay.

#### 3-3-6. Effect of preincubation of ethanol with whole blood on acetaldehyde formation.

Blood samples containing different concentrations of ethanol were deproteinized either immediately after ethanol had been added or 30 min. after ethanol addition; the samples being kept at room temperature. Preincubation had little effect on the production of acetaldehyde and typical results are shown in Fig. 3-5. These indicate that the acetaldehyde production must have been occurring during or after deproteinization.

#### 3-3-7. Acetaldehyde production in supernatants after deproteinization.

Acetaldehyde production from ethanol in protein-free blood supernatants was studied by adding ethanol to supernatant samples

FIGURE 3-4. AN ACETALDEHYDE CORRECTION CURVE PREPARED BY DEPROTEINIZING WHOLE BLOOD CONTAINING DIFFERENT AMOUNTS OF ETHANOL AND EMPLOYING A 10% DILUTION OF BLOOD.

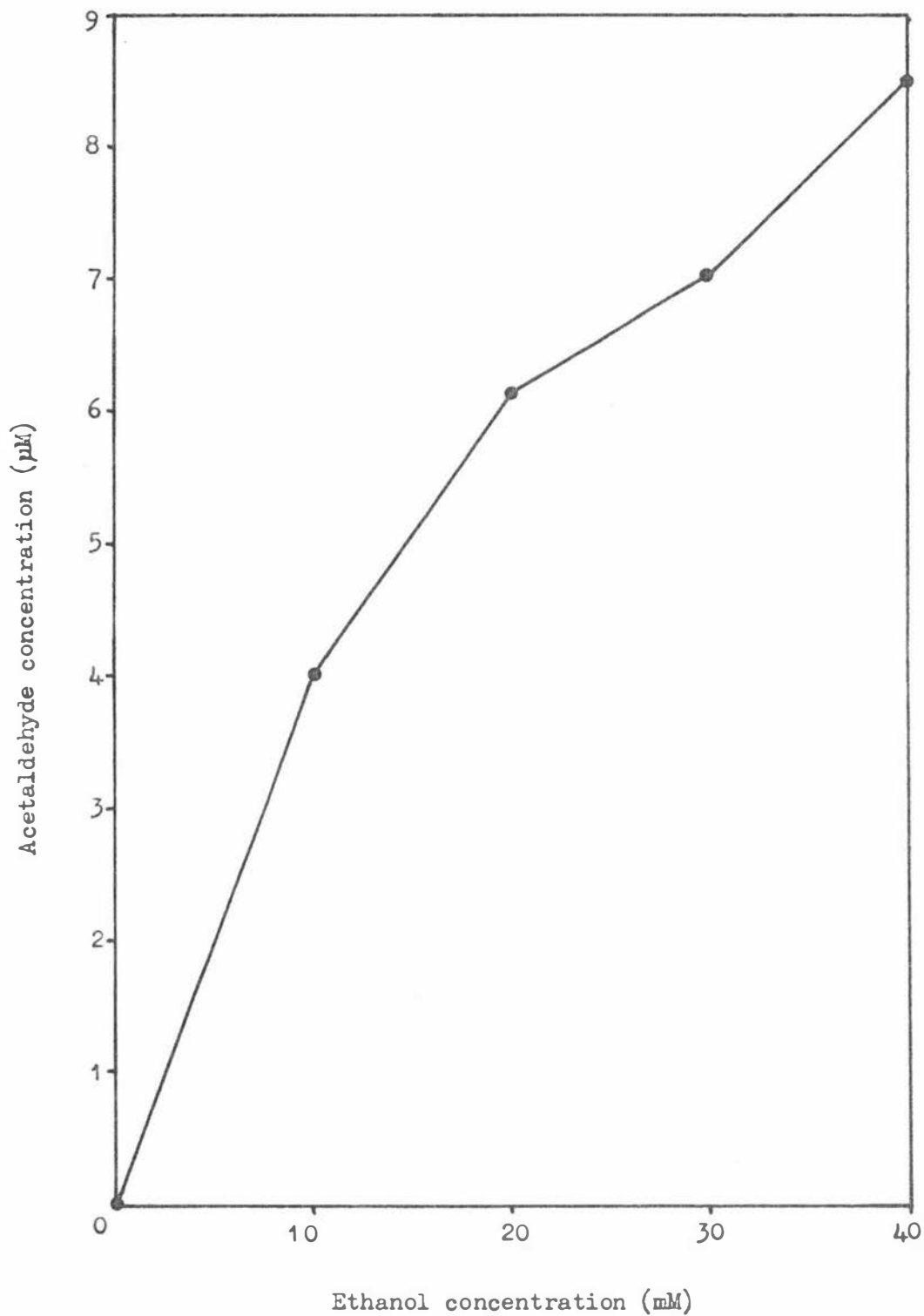

Each point is the mean of two determinations and concentrations refer to undiluted blood.

FIGURE 3-5. THE EFFECT OF PREINCUBATION ON THE PRODUCTION OF ACETALDEHYDE IN WHOLE BLOOD DEPROTEINIZED IN THE PRESENCE OF ETHANOL.

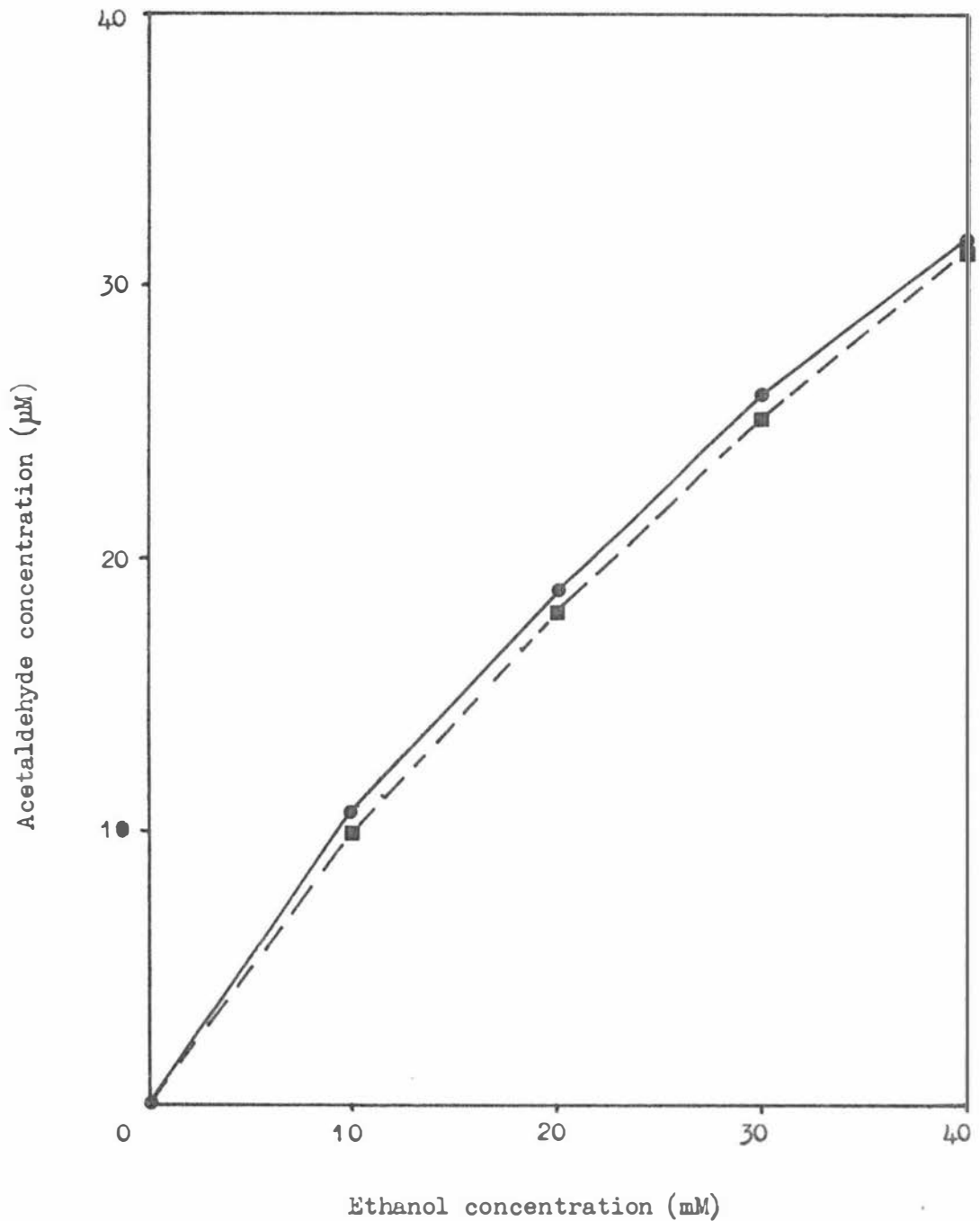

Dilution of the blood was 50% with 1M PCA and samples were deproteinized immediately after the addition of ethanol ( $\bullet$ ) or 30 min. after the addition of ethanol ( $\blacksquare$ ). Concentrations refer to undiluted blood and each point is the mean of two determinations.

at 4°C and then assaying them for acetaldehyde. Supernatant samples used for this experiment were obtained by a 50% dilution with 1M PCA. As shown in Fig. 3-6, production of acetaldehyde under these conditions was significant but very small. The small amounts of acetaldehyde obtained remained unchanged for at least 24h. if samples were stored at 4°C. Thiourea had no significant effect on this type of acetaldehyde production.

### 3-3-8. Effect of distillation temperature on acetaldehyde level.

Acetaldehyde formed by the addition of ethanol to blood followed by deproteinization in the normal way, using a 50% dilution, was assayed using two different distillation temperatures to determine whether any possible production of acetaldehyde during the distillation step was temperature dependent. It was found that the amount of acetaldehyde produced was not reduced by lowering the distillation temperature from 90 to 60°C.

### 3-3-8. Acetaldehyde production in ox blood.

During the course of this study, a rat-liver perfusion system was being developed in the laboratory to study liver ethanol and acetaldehyde metabolism. Ox blood red cells were used as the oxygen carrier in the artificial perfusate and acetaldehyde was measured in the perfusate after a PCA deproteinization. It was of interest to know whether ox blood behaved in a similar way to human blood with respect to the production of the acetaldehyde artefact. By carrying out experiments with ox blood, similar to those carried out on human blood, the following results were obtained.

Using the 50% dilution of blood, the acetaldehyde production in whole ox blood was large and variable but only about half the amount produced in human blood. This quantity appeared to be reduced slightly by adding 50 mM thiourea to the PCA solution.

Production of acetaldehyde in ox blood supernatants to which ethanol had been added after deproteinization was considerably larger than that found in human samples; 10 µM acetaldehyde was formed at the 20 mM ethanol level compared to about 1.5 µM in human samples containing the same ethanol concentration. This higher level was found to be reduced approximately to the human level in the presence of 25 mM thiourea in the protein-free supernatants. Incubation of the samples at 60°C for 15 min. before assay eliminated the effect of thiourea.

The levels of acetaldehyde in both types of supernatants mentioned

FIGURE 3-6. ACETALDEHYDE PRODUCTION IN PCA SUPERNATANTS OF WHOLE BLOOD WHERE ETHANOL HAS BEEN ADDED AFTER DEPROTEINIZATION.

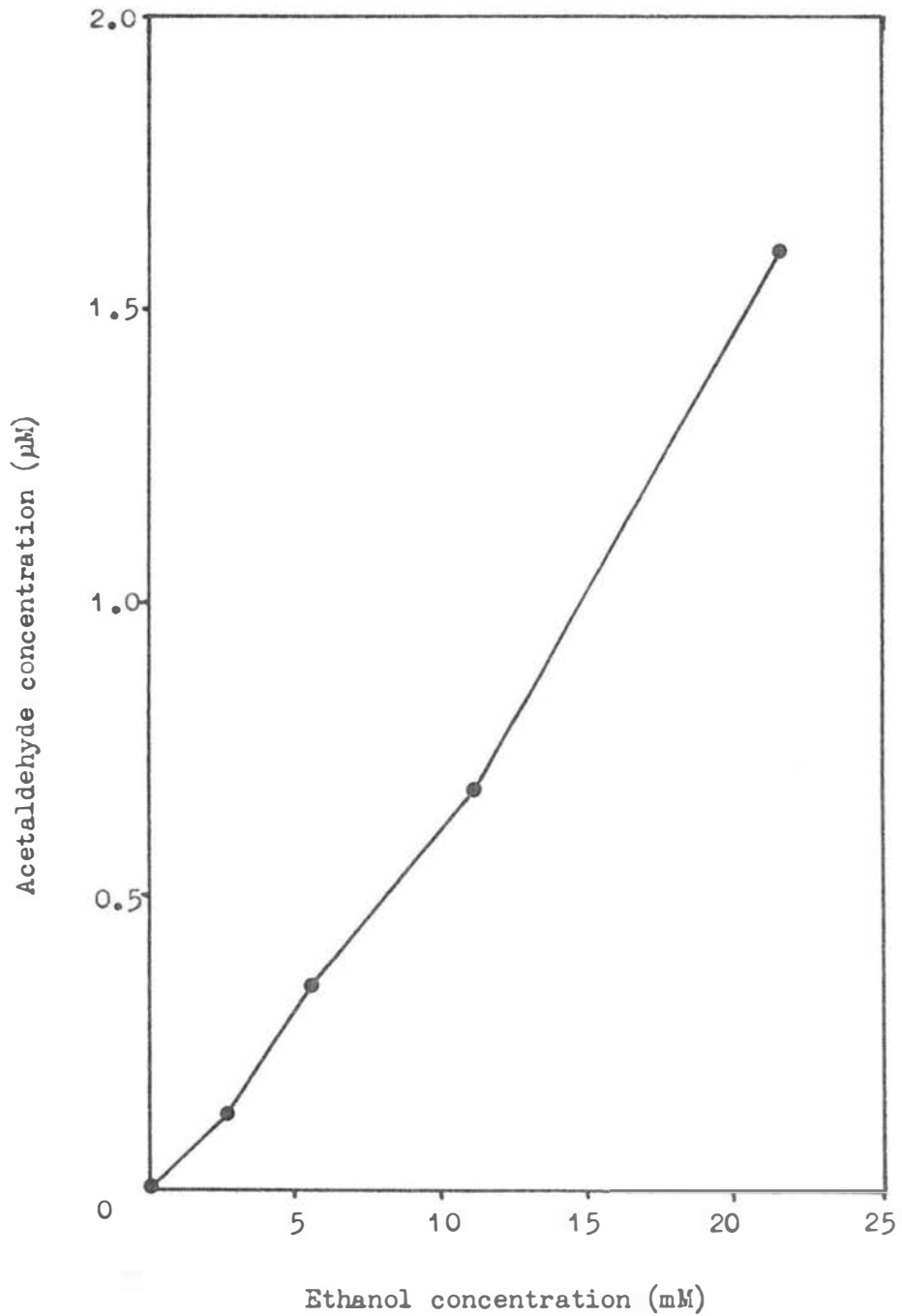

Blood supernatants were prepared by a 50% dilution with 1M PCA as described in the Methods Section and concentrations refer to the amounts of ethanol and acetaldehyde in the diluted blood supernatants. Each point represents the mean of duplicate determinations.

above remained constant when samples were stored at 4°C for 24h.

### 3-4. DISCUSSION.

From the results obtained in this study and others reported in the literature it is clear that there are major species differences in the amounts of acetaldehyde produced from ethanol during deproteinization of blood. Although large amounts are produced in human blood, no production of acetaldehyde has been found in blood of mice when PCA deproteinization has been employed (Ortiz et al, 1974). Truitt (1970) also found no artefact in mouse blood when  $ZnSO_4 - Ba(OH)_2$  was used as the protein precipitant. Negligible levels in rat, dog and rabbit blood were found by Truitt using the same deproteinization method but large and comparable amounts were formed in blood from humans, cows and monkeys. Acetaldehyde formation in rat blood has been found by other authors to be significant (Eriksson et al, 1975), negligible (Forsander et al, 1969; Eriksson, 1973; Sippel, 1973; Collins et al, 1976) or nonexistent (Tottmar and Marchner, 1975; Pettersson and Kiessling, 1976) when PCA deproteinization was used. However, when low levels of acetaldehyde are being measured, the sensitivity of the assay method used, largely determines whether the acetaldehyde can be detected or not. For example, the assays used by Tottmar and Marchner, and Pettersson and Kiessling, had a maximum sensitivity of 20  $\mu M$  and 6  $\mu M$  acetaldehyde respectively so this may account for the fact that the artefact was not observed. As noted in the Results Section, the magnitude of the artefact in human blood appears to be dependent on the extent to which blood samples are diluted and the different dilutions used by different workers could be responsible for the variations in the artefact produced in rat blood as well. For example, when Eriksson(1973) employed a 1:9 dilution of rat blood with 0.6 M PCA it was reported that the level of the artefact produced was negligible. However, when a 1:5 dilution was employed (Eriksson et al, 1975), relatively high levels were obtained ( $12.4 \pm 2.9$   $\mu moles$  of acetaldehyde/l of blood with a blood ethanol level of 10 mM). Variable results have been obtained with human blood and are probably also due to differences in the methods used to deproteinize blood samples.

The observation that the formation of acetaldehyde from ethanol added to rat liver supernatants may be almost completely eliminated with thiourea (Sippel, 1972; Eriksson et al, 1975) suggests that the mechanisms of artefact production in this tissue are different to those

forming acetaldehyde in human blood samples. It may be possible that different mechanisms are involved in blood of different species as well. This possibility was suggested by the fact that a high level of 'thiourea-inhibitable' acetaldehyde production was found to occur when ethanol was added to ox blood protein-free supernatants. This did not occur in human blood. It appears therefore, that any study of the artefact problem in one tissue of one species may not be applicable to other tissues from the same or different species. Because different workers have used different deproteinization procedures and assay techniques it is even difficult to compare all data obtained from studies of the artefact in either human or rat blood alone.

Nevertheless, the results obtained in this study, using the enzymic method of acetaldehyde analysis have confirmed some of those obtained by gas chromatographic (GC) analysis. The magnitude of the acetaldehyde levels produced in human blood, deproteinized using a 10% dilution, compare well with data published by Korsten et al (1975) who found that 4 and 10  $\mu\text{M}$  acetaldehyde was formed from 20 and 40 mM ethanol respectively whereas 6 and 10  $\mu\text{M}$  acetaldehyde was formed from the same ethanol concentrations in the experiments reported in this thesis.

The higher and more variable levels of acetaldehyde produced in human blood deproteinized using a 50% dilution were comparable with the levels reported by Eriksson et al (1975) using a 20% dilution of human blood and a GC assay method similar to that used by Korsten et al (1975). At this dilution, Eriksson et al found that  $16.5 \pm 4.4 \mu\text{M}$  acetaldehyde was produced from blood containing 10 mM ethanol compared to 14.3  $\mu\text{M}$  found in the present study using a 50% dilution. Eriksson performed his experiments by adding the ethanol to the PCA and not to the blood as in this study. However, since it was found that identical results were obtained using either method (see Section 3-3-4) his study and the present one are comparable except for the blood dilutions used and the assay technique. The finding of Truitt (1970) that both ox blood and human blood produced acetaldehyde at levels comparable to those found in this study when deproteinized with  $\text{ZnSO}_4 - \text{Ba}(\text{OH})_2$  in the presence of ethanol, suggests that the important factor in the production of the artefact is the deproteinization process itself and not the deproteinizing agent. MacLeod's (1950) finding that tungstic acid deproteinization of whole human blood results in a large artefact also supports this.

It was originally thought that treatment of blood samples at high temperature ( $60^\circ\text{C}$  for the GC assay and  $90^\circ\text{C}$  for the distillation step

in the enzymic assay) might be responsible for some artefact production. The fact that no significant artefact is produced when human blood supernatants containing ethanol added after deproteinization, were distilled and assayed, rules out this possibility, at least for the method used in this study, and suggests that the GC analysis system probably does not contribute to the artefact formation to any significant extent either. The lack of any effect of changing the distillation temperature from 60 to 90°C also suggests that the heating process is not responsible for the acetaldehyde production. From these findings, it seems that the large quantities of acetaldehyde in human samples which are measured by both methods, are formed during the deproteinization process only. Supporting this interpretation is the observation that preincubation of ethanol with human blood did not increase the artefact level. It can be calculated that if a blood sample containing 40 mM ethanol is deproteinized (50% dilution), about 93% of the acetaldehyde present in the supernatant must have been formed during the deproteinization reactions. Sippel (1972,1973) and Eriksson et al (1975) have assumed that the acetaldehyde production occurs by non-enzymic means in protein-free blood and liver extracts. The GC method used by these authors, however, involves a standard 15 min. incubation of the extracts to be analyzed, during which acetaldehyde in the liquid samples slowly equilibrates with a gas sample which is used for analysis. Using this method, no distinction can be made between acetaldehyde present in the extract before and after the equilibration period. Sippel (1972,1973) added ethanol to protein-free liver supernatants and not to fresh liver tissue and therefore it may be concluded that although some non-enzymatic ethanol oxidation does occur in rat liver supernatants, the process is probably not responsible for most of the acetaldehyde production in human blood. The stability of the artefact acetaldehyde levels with storage, with the finding that production of acetaldehyde in plasma is negligible compared to that in whole blood, further suggests that the artefact is introduced by reactions occurring during denaturation of the red-cell protein.

The effect of dilution on the magnitude of the acetaldehyde produced by deproteinization is unknown but may possibly be related to the speed at which deproteinization takes place. It was found that more effective and rapid mixing of the blood with the deproteinizing agent could be achieved using the 10% dilution. Alternatively, if some intermediate responsible for ethanol oxidation to acetaldehyde, is produced during the deproteinization process, its reaction with ethanol

may be concentration dependent. The possibility that ethanol could be releasing 'bound' acetaldehyde has not been ruled out by the results presented in this section but it is generally agreed in the literature that the acetaldehyde is formed directly from ethanol.

The absence of a thiourea effect on acetaldehyde production when a 50% dilution of blood was used was expected since Eriksson et al (1975) had shown that thiourea has little effect on acetaldehyde production in human blood apart from lowering the acetaldehyde recovery. This study confirms that thiourea does lower acetaldehyde recovery from supernatants of blood obtained by a 10% dilution with PCA but no such effect appears to occur with a 50% dilution (see Table 3-2). Korsten et al (1975) have stated that thiourea (25 mM) completely eliminated acetaldehyde formation from ethanol in blood diluted 1:9 with PCA. Although the use of this procedure in the present study more than halved acetaldehyde production, the decrease could be explained entirely by the lowered recovery; it did not eliminate acetaldehyde formation altogether. The reason for such a discrepancy is not clear but could be related to the relative sensitivity of the two different assay methods used.

Although a full explanation of the acetaldehyde artefact problem, as it occurs in human blood, has not been found, it was considered that satisfactory blood acetaldehyde data could be obtained from human volunteers provided correction curves of the type shown in Fig. 3-4 were used for each individual studied. This procedure has been adopted by Korsten et al (1975). Any previous studies on acetaldehyde levels in human blood which have not employed such a correction (i.e. all except the study carried out by Korsten et al (1975)) must be considered unreliable even though there is a possibility that methods of assay not employing deproteinization may not result in the type of artefact production described here. However, as mentioned in the introduction, acetaldehyde may be produced in large quantities in ethanol-containing blood under certain conditions if the blood is not deproteinized. This production has been found to vary according to the degree of haemolysis of blood (Truitt, 1970) and also to the blood temperature (Smalldon and Brown, 1973). The use of deproteinization at least produces a reproducible artefact which can be quantitated and corrected for if standard deproteinization conditions are used.

## SECTION 4.

DISAPPEARANCE OF ACETALDEHYDE IN BLOOD SAMPLES.4-1. INTRODUCTION.

It was noted in Section 3-3-2 that the problems associated with the measurement of acetaldehyde in human whole blood samples could be overcome by using plasma, the deproteinization of which gave only negligible amounts of acetaldehyde as an artefact. However, as was also noted in Section 3-3-2, acetaldehyde added to whole blood could not be completely recovered if plasma was used for the analysis. This was assumed to be due to the partial metabolism of added acetaldehyde during the time required for separation of the plasma from the whole blood.

The time between the drawing and subsequent deproteinization of the blood samples taken from human subjects was approximately 30 seconds and so, if the disappearance of acetaldehyde in whole blood was fast enough, significant losses of acetaldehyde initially present in blood samples could occur during the sampling procedure and give low assay values. Accordingly, it was considered necessary to determine accurately the rate of acetaldehyde disappearance in human venous blood during times corresponding to those required to take blood and separate the plasma.

It has been known for some time that acetaldehyde is removed when added to whole human blood but the rate of disappearance has been studied only at much higher concentrations than those expected to exist in venous blood samples taken from humans metabolizing ethanol. For example, Duritz and Truitt (1964) measured the decay of acetaldehyde in human venous blood from initial levels between 0.45 and 2.3 mM. These levels may be contrasted with actual levels of acetaldehyde found in human venous blood by Korsten et al (1975) of between 3 and 45  $\mu\text{M}$  at blood ethanol levels up to 54 mM. It was decided, therefore, to determine the rates of disappearance of acetaldehyde in blood at 'physiological' concentrations and to study some of the variables which might affect these rates.

The possibility that the observed acetaldehyde disappearance was due, at least in part, to the binding of acetaldehyde to blood proteins

rather than its conversion to other substances was considered and an experiment was carried out to test this possibility. It was considered important to identify any protein binding since the existence of acetaldehyde in 'free' and 'bound' forms could mean that blood levels of acetaldehyde determined by gas-chromatographic and enzymic assay methods may not represent the total amounts of acetaldehyde present in blood.

#### 4-2. MATERIALS AND METHODS.

##### 4-2-1. Reagents.

Ethanol ( $1-^{14}\text{C}$ ) with a specific activity of  $51.4 \text{ mCi/mmole}$  and a radiochemical purity of  $98\%$  was obtained from the Amersham Radiochemical Centre, Bucks., England.

Scintillation grade (1,4-Di(2-(5-phenyloxazolyl))Benzene) (POPOP), was obtained from Hopkin and Williams, Chadwell Heath, Essex, England.

Reagent grade 2,5-diphenyloxazole (PPO) was obtained from BDH Chemicals Ltd., Poole, England.

The scintillation solvent used for radioactivity determinations was prepared as follows :- one volume of Triton X100 was mixed with two volumes of redistilled toluene; PPO and POPOP were dissolved in this mixture to give final concentrations of  $4\text{g/l}$  and  $0.2\text{g/l}$  respectively.

##### 4-2-2. Determination of radioactivity.

Radioactivity determinations were carried out in a Beckman LS 350 liquid scintillation counter and corrections for quenching were made using an external standard. Counting efficiencies for samples were within the range of  $84 - 87\%$ .

##### 4-2-3. Blood samples.

Samples of fresh human venous blood treated with heparin or EDTA, or fresh oxalated ox blood were used for all experiments. The human blood was obtained in all cases from an antecubital vein and, unless otherwise stated, the additions of acetaldehyde, ethanol and acetate solutions to blood or plasma samples were made in such a way that the required reagent concentrations were obtained in samples without increasing their volumes by more than  $2\%$ . Human blood samples containing endogenous ethanol and acetaldehyde were obtained from healthy volunteers who had previously consumed  $1\text{g/kg}$  of ethanol as vodka,  $1.5 - 2\text{h.}$  before the blood samples were taken.

Some experiments were performed with washed human red blood cells and these were prepared as follows:- fresh heparinized human blood was centrifuged and the plasma and buffy coat removed by aspiration. The red cells were washed three times at 4°C with two volumes of Krebs-Ringer phosphate solution containing 6.7 mM glucose and finally suspended in this solution to give haematocrit values between 8.0 and 15.0%.

Acetaldehyde disappearance in different blood, plasma or red cell samples was determined by assaying aliquots taken at different times after acetaldehyde was mixed with the samples. The incubations of acetaldehyde with blood or blood fractions was carried out in all cases in sealed containers, to minimize acetaldehyde losses from evaporation.

#### 4-2-4. Sample treatment and assay methods.

For all experiments except those involving washed red cells, samples were assayed using either the semi- or fully automated enzymic methods described in Section 2. Samples to be assayed were diluted with either one volume of ice-cold 1M perchloric acid (PCA) or nine volumes of ice-cold 0.6M PCA followed by centrifugation. The PCA stopped the acetaldehyde disappearance, stabilizing remaining acetaldehyde levels. The clear protein-free supernatants obtained were assayed for acetaldehyde. Aqueous acetaldehyde standards were used in all experiments.

Where washed red cell suspensions were used, the assay of acetaldehyde was performed using essentially the same method described by Burbridge et al (1950), the only modification being the treatment of all samples with one volume of ice-cold 1M PCA and centrifugation before assay. The method of Burbridge et al employs tungstic acid deproteinization with no separation of denatured protein from the rest of the sample before the assaying of samples. Assays for acetaldehyde were performed on both PCA- treated cell-free supernatants obtained by centrifugation of the red cell suspensions at 4°C, and protein-free supernatants obtained after treatment of aliquots of the mixed cell suspensions with PCA. In both cases, 2 ml of the PCA supernatants were placed in the outer compartment of the Conway diffusion dishes used for the assay method. The recoveries of acetaldehyde from both types of PCA solution were found to be 100% compared with recoveries from aqueous solutions.

Blood ethanol levels were determined by a gas chromatographic method involving the analysis of head-space gas equilibrated with PCA supernatants of blood samples. Gas samples were chromatographed on a

Porapak Q<sup>1</sup> column at 130°C with a carrier gas flow rate of 40 ml/min. Acetonitrile was used as an internal standard. This method has been described fully by Couchman (1974).

#### 4-2-5. Use of <sup>14</sup>C-labelled acetaldehyde.

In an experiment to determine whether acetaldehyde is metabolized by whole blood to a non-volatile compound or possibly bound to blood protein, the 1-<sup>14</sup>C acetaldehyde used was formed from 1-<sup>14</sup>C ethanol by the methods described in Appendix I. Details for this experiment follow:

Acetaldehyde (1-<sup>14</sup>C) was distilled into a small volume (about 10 ml) of ice-cold water using the regeneration technique described in Appendix I. To the solution obtained, sufficient carrier acetaldehyde, NaCl and water were added to produce 50 ml of a 0.9% NaCl solution containing 46 μM acetaldehyde. This solution (20 ml) and a sample of human blood (20 ml) were brought to 37°C in separate sealed containers, mixed and placed in a sealed flask at 37°C. Aliquots (5 ml) were taken from the reaction vessel at intervals up to 40 min. after the mixing of the blood with the saline solution and added to ice-cold 1M PCA solution (5 ml). A blank sample was prepared by deproteinizing a 1:1 v/v mixture of blood and 0.9% saline solution which did not contain added acetaldehyde.

In a control experiment, one volume of 0.9% saline solution was mixed with one volume of the saline/1-<sup>14</sup>C -acetaldehyde solution described above; the mixture being incubated for 40 min. at 37°C. Two samples were taken from the mixture into one volume of ice-cold 1M PCA (as described previously), one at zero time (i.e. the time of mixing) and one 40 min. later.

All PCA-treated samples were centrifuged and different aliquots of the protein-free supernatants were used for

- (a) acetaldehyde assays
- (b) determination of total radioactivity
- and (c) determination of radioactivity in non-volatile substances.

For (b), two 1 ml samples of each PCA supernatant were added to 10 ml of scintillation solvent. For (c), 2 ml samples of each supernatant were added to 2 ml of 1.2M KHCO<sub>3</sub> to bring the pH to 7.4. Potassium chlorate

---

1. Obtained from Waters Associates Inc., Framingham, Mass., U.S.A.

was allowed to crystallize out and 2 ml of the neutralized solutions were evaporated to half their volumes at 40°C. The solutions were made up to 2 ml again and duplicate 0.9 ml aliquots were added to 10 ml of scintillation solvent with 0.1 ml of water.

#### 4-3. RESULTS.

##### 4-3-1. Comparison of the rates of disappearance of acetaldehyde in human whole blood and plasma samples at 4°C and 37°C.

Acetaldehyde disappearance in blood samples from an initial level of 10  $\mu\text{M}$  is not only dependent on temperature but is also dependent, to a large extent, on the presence of blood cells (Fig. 4-1). The results shown in Fig. 4-1 are single determinations using blood from one individual. As for all subsequent experiments described in this section, the values have been corrected for the very small amounts of acetaldehyde detectable in blood samples to which no acetaldehyde had been added. Blank levels in samples used for this experiment were approximately 1.0  $\mu\text{M}$  in whole blood but near zero in plasma. Blood and plasma aliquots were diluted with one volume of PCA and the maximum error for the values would be  $\pm 0.5 \mu\text{M}$ .

##### 4-3-2. Individual variations in blood acetaldehyde disappearance rates.

The disappearance of acetaldehyde at 37°C from an initial added level of 20  $\mu\text{M}$  was studied in blood samples from seven individuals (two males and five females). Aliquots of the blood samples containing added acetaldehyde were deproteinized with one volume of PCA. The results shown in Figs. 4-2 and 4-3 show that there is little individual variation in the disappearance rate and that the rate is exponential. Some of the blood samples used for this experiment were heparinized and for others, EDTA was used as the anticoagulant. No significant difference was found between the acetaldehyde disappearance rates in blood samples containing different anticoagulants. Experiments were performed separately on each blood sample and they were stored at 4°C until required. The time between the testing of the first and last sample was 5h. and storage at 4°C for this time did not significantly affect the rate of removal of acetaldehyde.

Blank acetaldehyde levels found in the seven different blood samples were; 0.5, 1.1, 4.8, 1.1, 0.7, 1.1 and 1.3  $\mu\text{M}$ . In all cases the added acetaldehyde was found to decay almost to these blank levels in 24 min. From Fig. 4-3 an average half-life for acetaldehyde of about 3 min. can

FIGURE 4-1. DISAPPEARANCE OF ACETALDEHYDE ADDED TO HUMAN WHOLE BLOOD AND PLASMA SAMPLES AT 4°C AND 37°C.

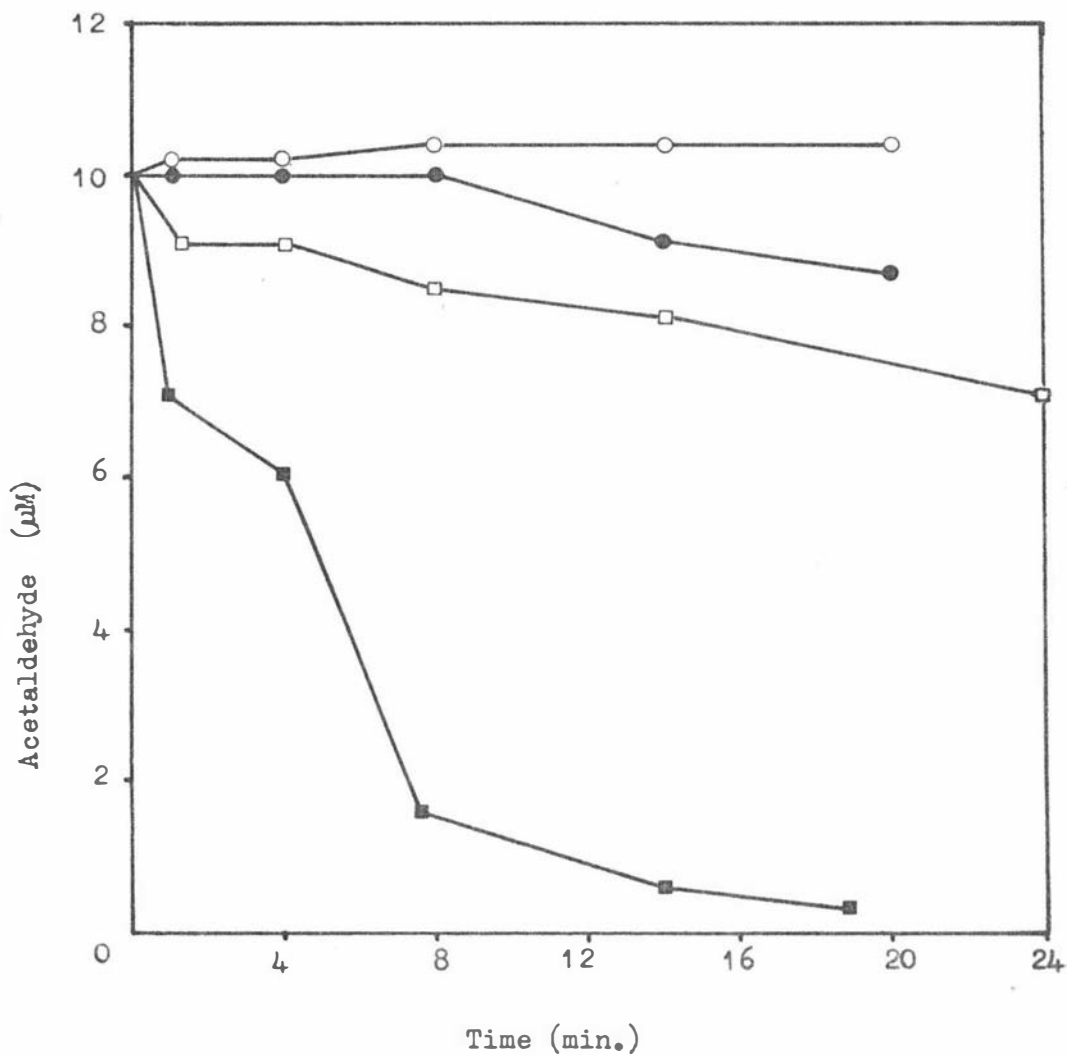

KEY.

- Plasma incubated at 4°C (○)
- Plasma incubated at 37°C (●)
- Whole blood incubated at 4°C (□)
- Whole blood incubated at 37°C (■)

FIGURE 4-2. INDIVIDUAL VARIATIONS IN ACETALDEHYDE DISAPPEARANCE IN HUMAN BLOOD SAMPLES AT 37°C.

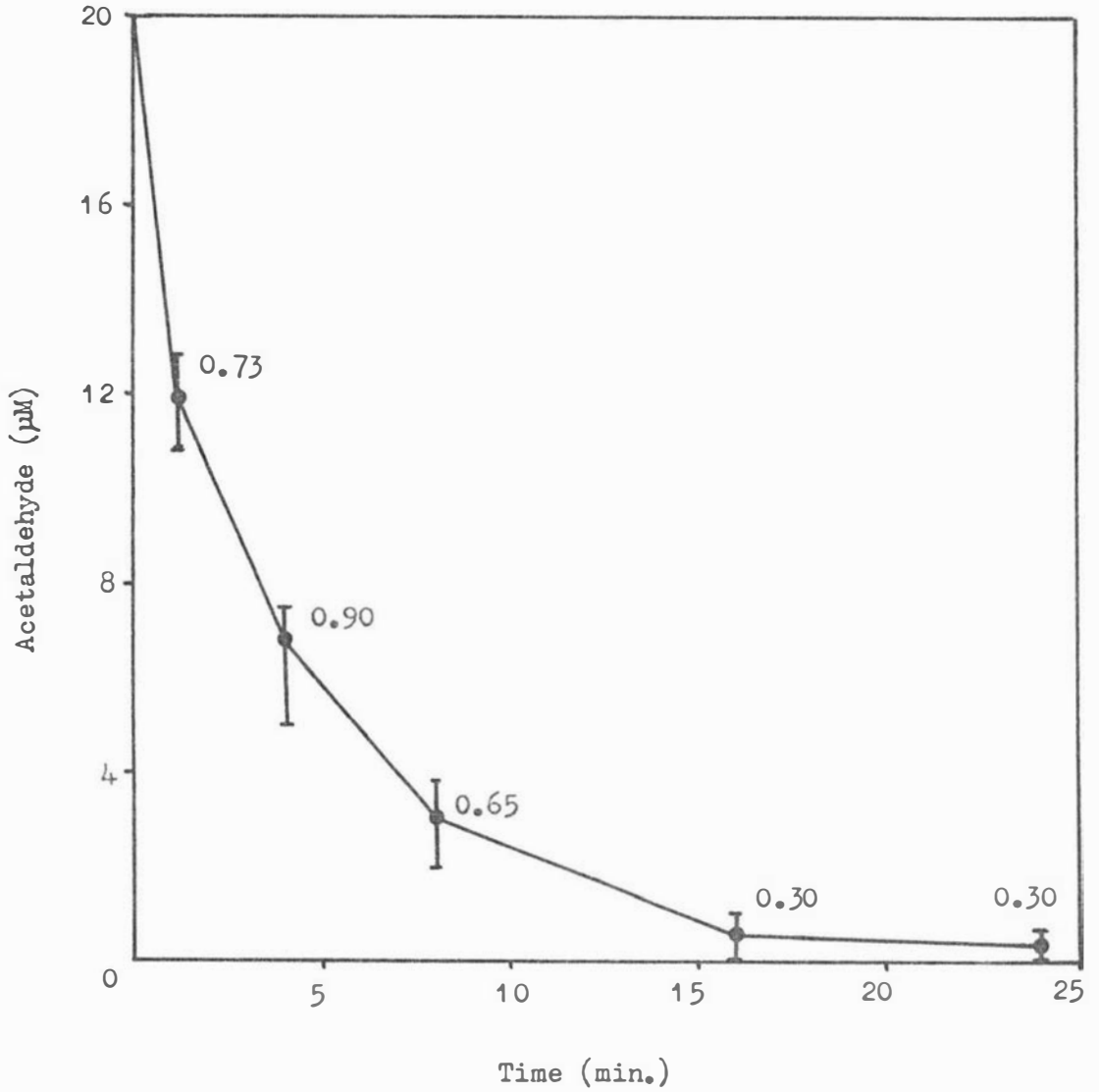

The points in the above figure represent the means of seven determinations, using blood samples obtained from seven individuals. The bar lines represent the range of values obtained and the figures by each point represent one standard deviation.

be calculated and about 22% of the added acetaldehyde disappeared in 30 seconds after mixing acetaldehyde with the blood samples.

#### 4-3-3. Effect of haemolysis on acetaldehyde disappearance in human blood.

Acetaldehyde disappearance at 37°C in haemolyzed and non-haemolyzed blood from one individual was determined. A haemolyzed blood sample was prepared by diluting 5 ml of whole blood to 10 ml with distilled water and the non-haemolyzed control was prepared by diluting 5 ml of blood to 10 ml with 0.9% NaCl. Acetaldehyde was added to both samples at 37°C to increase the acetaldehyde concentration by 20  $\mu$ M and aliquots of the samples taken at different times were treated with one volume of PCA.

Figure 4-4 shows that although haemolysis does significantly lower the rate of disappearance of acetaldehyde, this rate is still rapid in haemolyzed blood.

#### 4-3-4. Disappearance of acetaldehyde in human blood which has been frozen and thawed.

The rate of disappearance of acetaldehyde added to blood which had been frozen for 3 days, thawed and brought to 37°C is shown in Fig. 4-5. Although the rate was significantly lower than that observed with fresh unfrozen blood, rapid loss still occurred. This indicates that if the mechanism responsible for the acetaldehyde loss is enzymic then the enzyme responsible must be stable to freezing and thawing.

#### 4-3-5. Disappearance of endogenous acetaldehyde in blood samples taken from subjects metabolizing ethanol.

Although it was clear that acetaldehyde rapidly disappears when added in vitro to blood containing little or no endogenous acetaldehyde or ethanol, it was considered worthwhile to determine whether the same rate of disappearance occurred in blood samples containing acetaldehyde which had been formed from ethanol, in vivo.

Blood samples were taken from subjects metabolizing ethanol and aliquots were deproteinized at intervals prior to estimating acetaldehyde levels present. The results of such experiments are shown in Fig. 4-7. A 1:9 dilution of blood aliquots with PCA was used to avoid excessive artefact acetaldehyde formation. The levels of artefact production were determined for each blood sample using a correction curve prepared

FIGURE 4-3. SEMILOGARITHMIC PLOT OF THE DATA PRESENTED IN FIGURE 4-2.

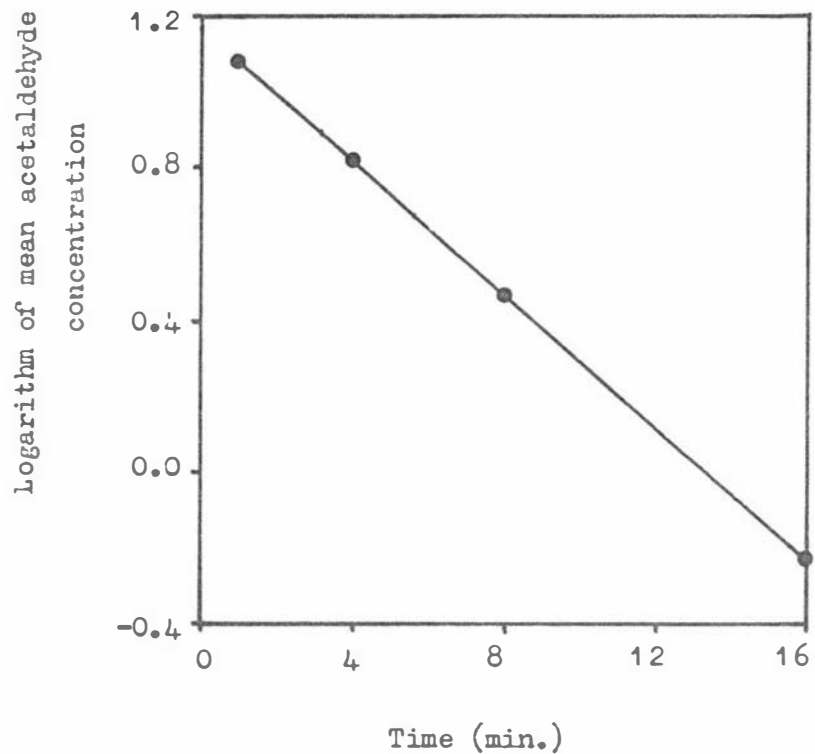
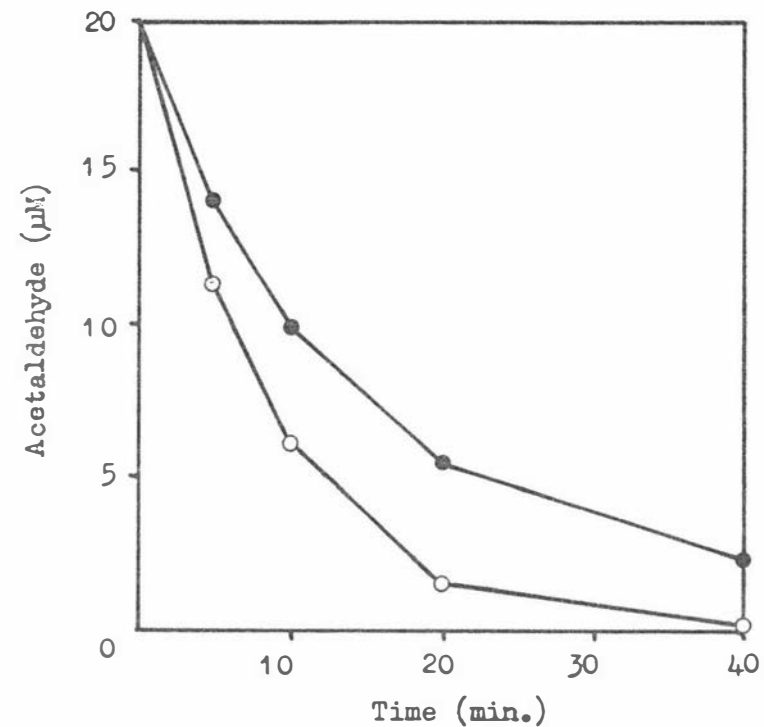

FIGURE 4-4. THE EFFECT OF HAEMOLYSIS ON THE DISAPPEARANCE OF ACETALDEHYDE IN HUMAN BLOOD AT 37°C.



Haemolyzed blood (●)

Non-haemolyzed blood (○)

The points in the above figure represent single determinations.

FIGURE 4-5. DISAPPEARANCE OF ACETALDEHYDE IN HUMAN BLOOD WHICH HAS BEEN FROZEN AND THAWED.

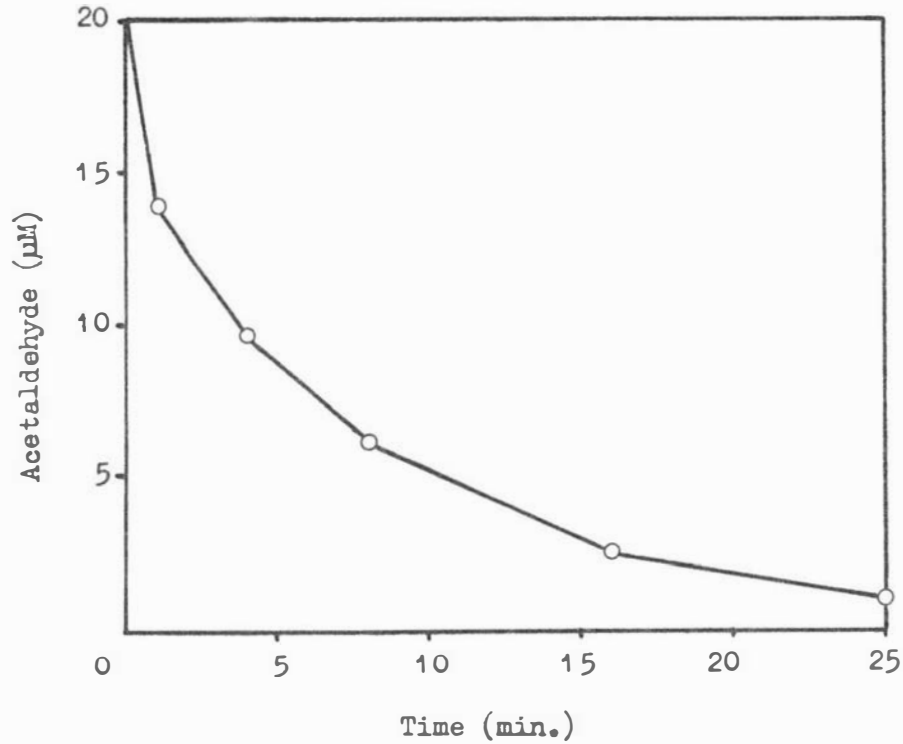
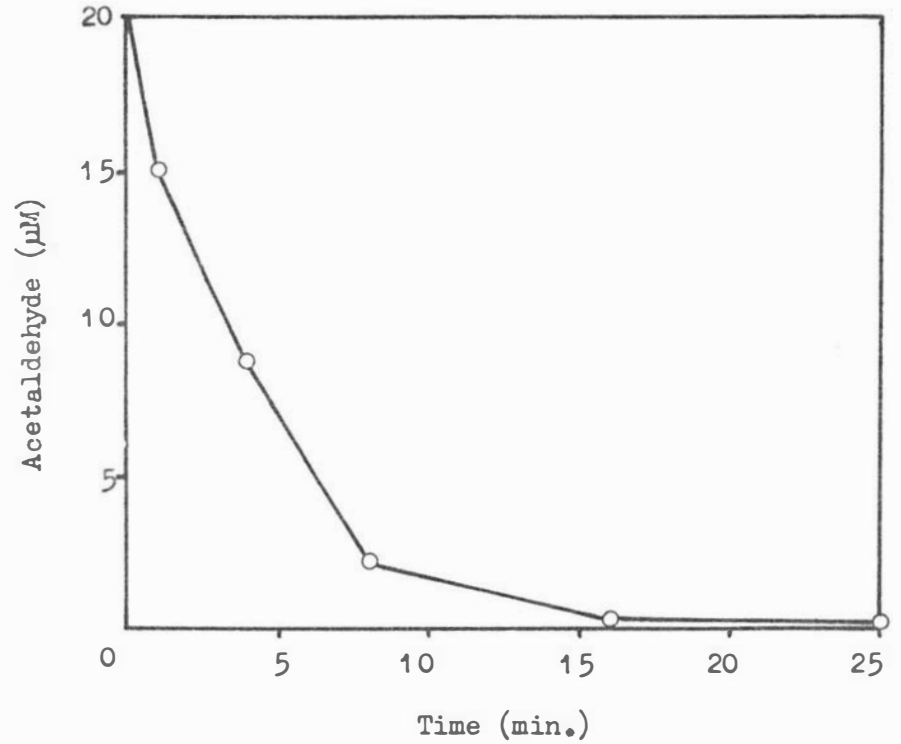
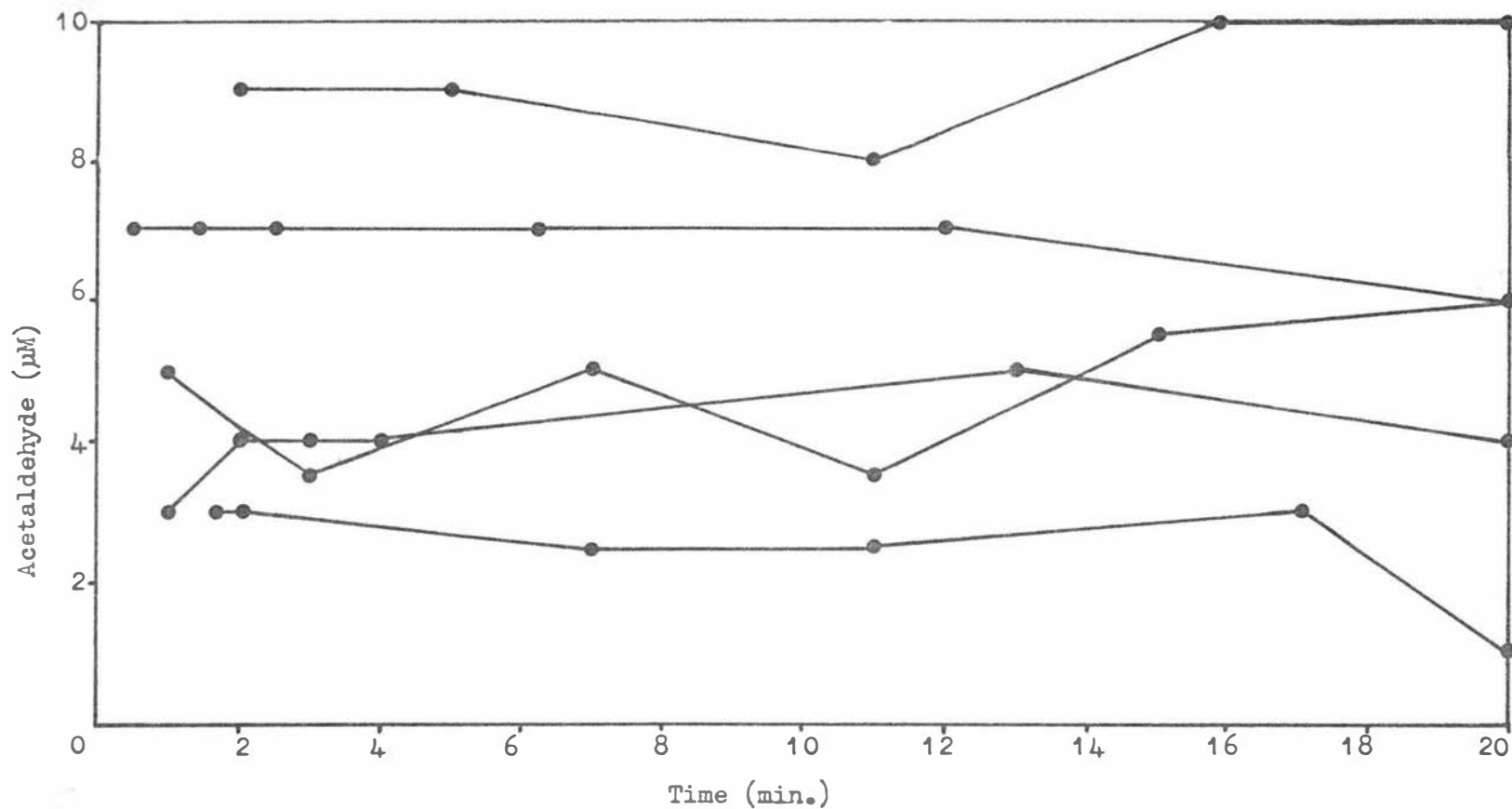

FIGURE 4-6. DISAPPEARANCE OF ACETALDEHYDE IN FRESH OX BLOOD.



The points in the above figures represent the results of single determinations. Acetaldehyde was added to the blood samples to produce an initial concentration of 20 µM and the samples were incubated at 37°C.

FIGURE 4-7. CHANGES IN THE CONCENTRATIONS OF ENDOGENOUS ACETALDEHYDE IN BLOOD SAMPLES TAKEN FROM SUBJECTS METABOLIZING ETHANOL.



The four blood samples were incubated at  $37^{\circ}\text{C}$  and the time refers to the time elapsed after the samples were taken. Acetaldehyde concentrations have been corrected for artefact acetaldehyde production.

by deproteinizing blank blood samples (obtained before alcohol was consumed) containing added ethanol and assaying these, in the manner described in Section 3. The artefact level in each sample from subjects metabolizing alcohol was determined from the correction curve after the ethanol level of the sample had been determined. Incubations of blood samples were carried out at 37°C. The results obtained were in striking contrast to those obtained in the previous experiments. Although the level of acetaldehyde measured above the artefact level appeared to fluctuate throughout the incubation period, no significant disappearance was observed. Since these blood samples contained ethanol and, presumably, acetate formed from ethanol, it was possible that the presence of these two compounds might be responsible, in some way, for the absence of a rapid disappearance rate in endogenous acetaldehyde levels. An experiment was therefore carried out to test this possibility.

4-3-6. The effect of ethanol and acetate on the disappearance of acetaldehyde added to blood in vitro.

Acetate and ethanol were added to blood to give concentrations of 1 mM and 20 mM respectively, to determine if their presence alone or in combination affected the disappearance of acetaldehyde which was also added to blood. Acetate has been shown to reach levels of about 0.5 - 1.0 mM in human venous blood after ethanol intakes of 0.5g/kg body weight (McLean, 1975) and 20 mM ethanol was found to be a normal level after administration of ethanol doses of 1g/kg. The blood used for this experiment was obtained from one individual and incubated at 37°C with the added reagents. To reduce artefact acetaldehyde formation from ethanol, aliquots of the incubated blood were deproteinized with nine volumes of PCA and assayed as described in the Methods section. Because this higher dilution was used, acetaldehyde was added to blood at an initial concentration of 100 µM in order to obtain a large difference between the artefact level and the actual level of added acetaldehyde. A control experiment was also performed to determine whether any acetaldehyde disappearance occurred in an aqueous solution containing only heparin at the same concentration present in blood and under the same incubation conditions employed for blood samples. The results are shown in Fig. 4-8 and indicate that acetate and ethanol alone or in combination do not inhibit acetaldehyde disappearance in blood when these substances are added in amounts commonly found in human blood during ethanol metabolism. The higher elevation of the curves for samples containing ethanol is due entirely to the presence

FIGURE 4-8. THE EFFECT OF ETHANOL AND ACETATE ON THE DISAPPEARANCE OF ACETALDEHYDE ADDED TO WHOLE BLOOD IN VITRO.

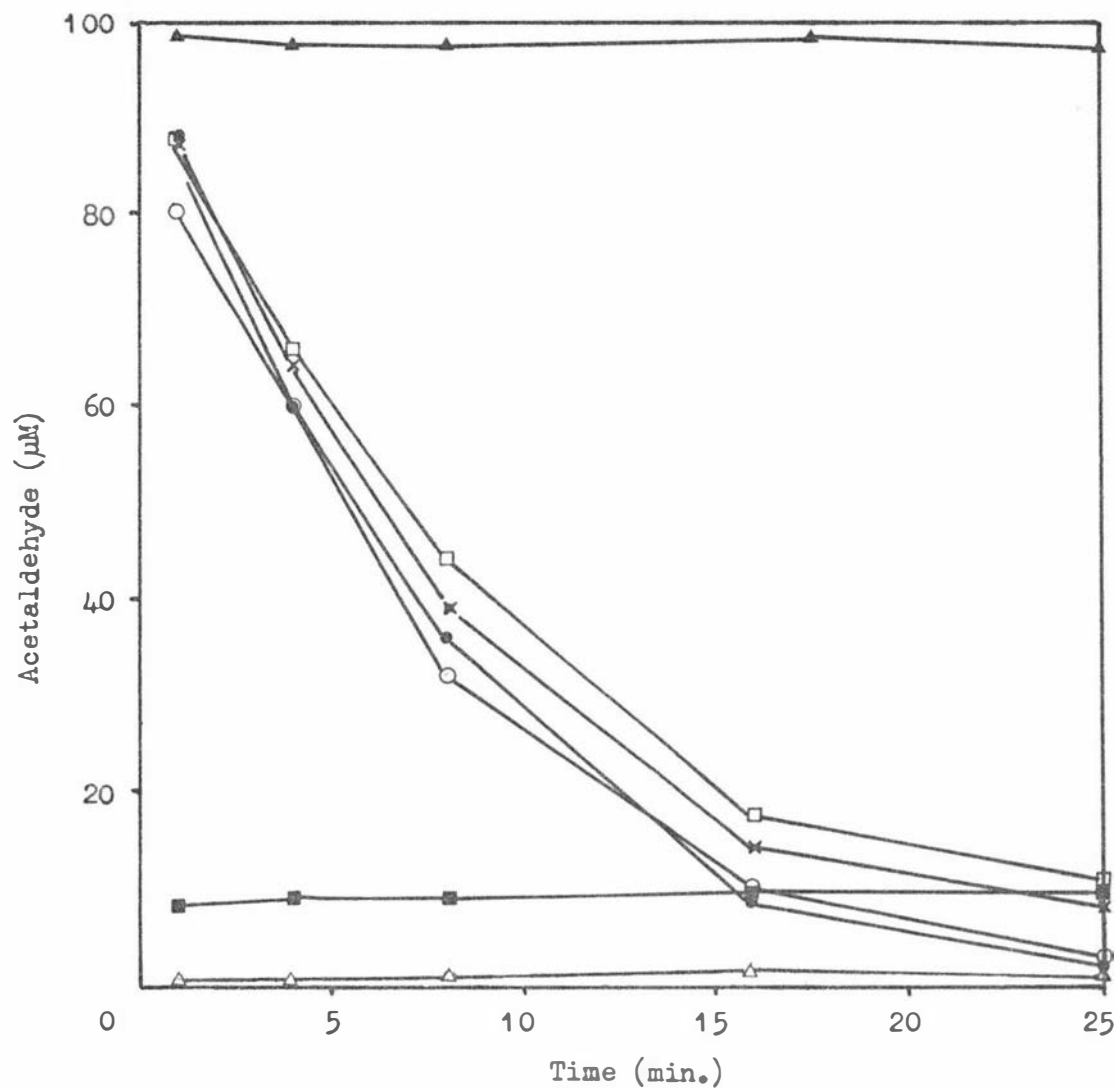

KEY.

- Water + heparin + acetaldehyde (control) (▲)
- Blood + acetaldehyde (●)
- Blood + acetaldehyde + acetate (1mM) (○)
- Blood + acetaldehyde + acetate (1mM) + ethanol (20mM) (□)
- Blood + acetaldehyde + ethanol (20mM) (×)
- Blood + ethanol (20mM) (■)
- Blood + acetate (1mM) (△)

Acetaldehyde was added to samples to produce initial concentrations of 100  $\mu\text{M}$  and all incubations were performed at 37°C. No correction for artefact acetaldehyde production has been made.

of acetaldehyde produced from ethanol as an artefact.

4-3-7. Disappearance of added acetaldehyde from blood samples taken from subjects metabolizing ethanol.

The results of the experiments described in the previous two sections suggested that added acetaldehyde was in some way different to the detected acetaldehyde in blood from subjects metabolizing ethanol. Acetaldehyde added to blood in vitro disappears rapidly while acetaldehyde formed in vivo does not disappear. To examine this situation further, acetaldehyde was added to blood samples containing acetaldehyde formed from ethanol in vivo and its disappearance was measured. At the same time, the levels of acetaldehyde in blood samples containing ethanol were determined in a sample to which no acetaldehyde had been added. This experiment was performed several times at two different temperatures (37°C and room temperature) using blood samples taken from different individuals. In each case a similar result was obtained. A typical result is shown in Fig. 4-9 and indicates that in the same blood sample, acetaldehyde formed from ethanol in vivo does not disappear significantly over a period of 20 min. after the blood sample has been taken from a subject metabolizing ethanol, while added acetaldehyde disappears rapidly. The disappearance of the added acetaldehyde is temperature dependent while the incubation temperature has no effect on the level of acetaldehyde formed from ethanol in vivo.

4-3-8. Fate of acetaldehyde added to human blood.

When  $1-^{14}\text{C}$  acetaldehyde was added to blood samples the radioactivity in volatile compounds declined at essentially the same rate as acetaldehyde disappeared, while the counts in non-volatile compounds increased at this same rate (Fig. 4-10). It was clear that acetaldehyde was not being converted to a volatile product such as ethanol and the results suggested that acetaldehyde was being converted to a non-volatile compound such as acetate. If the decay of acetaldehyde in diluted blood was due to binding to protein then the total counts in PCA supernatants would be expected to decline at the same rate as the acetaldehyde. However, only a slight decrease in total counts was observed in the PCA supernatants. In the control experiment no significant loss of acetaldehyde or radioactivity occurred during the 40 min. incubation period at 37°C.

FIGURE 4-9. THE DISAPPEARANCE OF ADDED ACETALDEHYDE FROM HUMAN BLOOD SAMPLES TAKEN FROM A SUBJECT METABOLIZING ETHANOL.

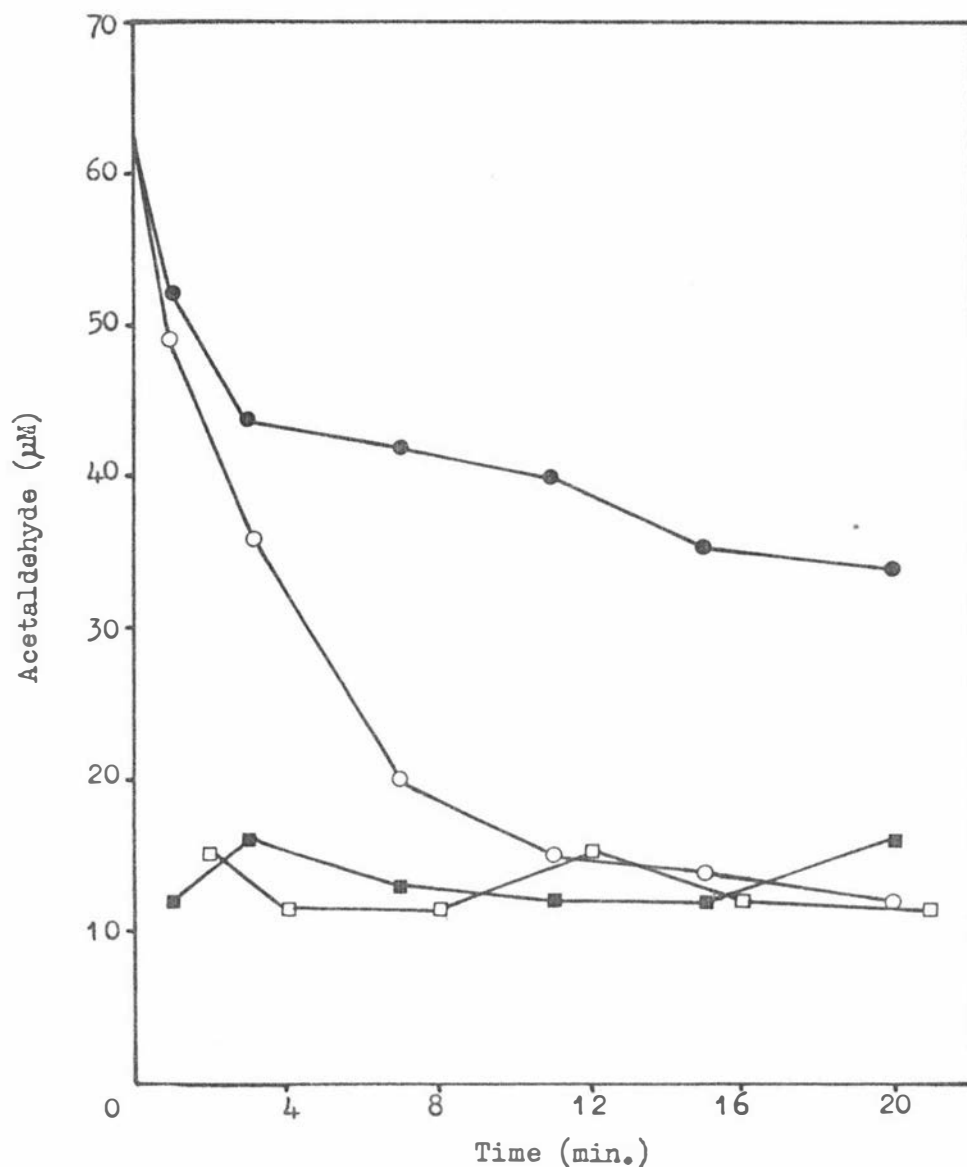

KEY.

Blood incubated at room temperature (■)

Blood incubated at 37°C (□)

Blood incubated at room temp. + 50µM acetaldehyde (●)

Blood incubated at 37°C + 50µM acetaldehyde (○)

Acetaldehyde concentrations have been corrected for artefact acetaldehyde production and the addition of acetaldehyde to samples was carried out directly after the samples were taken.

FIGURE 4-10. THE METABOLISM OF 1-<sup>14</sup>C ACETALDEHYDE BY HUMAN BLOOD IN VITRO.

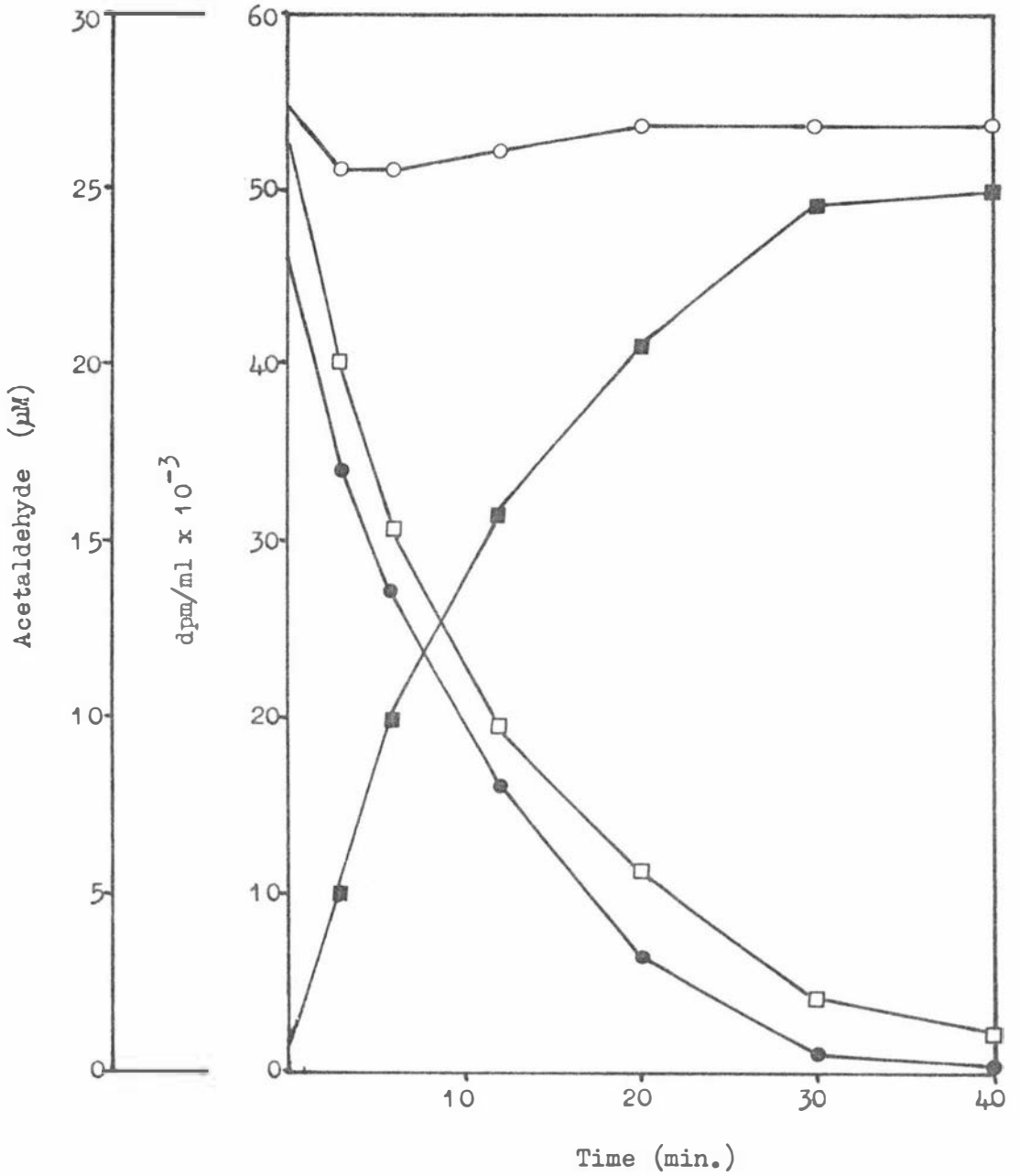

KEY.

- Total radioactivity (○)
- Volatile radioactivity (□)
- Non-volatile radioactivity (■)
- Acetaldehyde (●)

#### 4-3-9. Disappearance of acetaldehyde in washed red blood cell suspensions.

The disappearance of higher levels (250  $\mu\text{M}$ ) of acetaldehyde was studied with human erythrocyte suspensions by the procedures described in the Methods section. The half-life of acetaldehyde in the suspensions was found to be directly proportional to the red cell concentration (Fig. 4-11) and the rate of disappearance of acetaldehyde in the cell-free Krebs-Ringer phosphate medium was the same as that observed with whole cell suspensions (Fig. 4-12). In cases where the concentrations of acetaldehyde in cell-free media were determined, acetaldehyde disappearance was considered to have stopped once the cells were separated from the medium. Accordingly, acetaldehyde concentrations in Fig. 4-12 are plotted against time of separation (or time of deproteinization when acetaldehyde concentrations in the whole cell suspensions were measured). Although these results do not prove that the erythrocyte fraction of blood is entirely responsible for the rapid disappearance of acetaldehyde, they suggest that the red cells contain mechanisms for most of the acetaldehyde removal.

The high level of acetaldehyde used in these experiments was necessary because of the limited sensitivity of the assay system employed. The experiments with washed red cells were carried out before the more sensitive enzymic assays were developed.

#### 4-3-10. Disappearance of acetaldehyde in ox blood.

Ox blood red cells were used in the medium for perfusing rat livers (see Section 7) and it became necessary to determine the disappearance rate for acetaldehyde in this system. It was found that although the decline of acetaldehyde in whole ox blood is very similar to that which occurs in human blood (see Fig. 4-6), the decrease in the amount of acetaldehyde added to the perfusion medium at 37°C in concentrations between 20 and 200  $\mu\text{M}$  was much slower and more variable. This was also true for acetaldehyde produced by the liver from added ethanol. Since sampling and deproteinization of perfusate samples were always completed in less than 1 min. and no significant losses of acetaldehyde in the perfusate occurred within this time, no corrections for acetaldehyde loss were considered necessary for perfusion experiments.

### 4-4. DISCUSSION.

#### 4-4-1. Disappearance of acetaldehyde added to blood samples.

FIGURE 4-11. GRAPH OF HAEMATOCRIT VERSUS THE HALF-LIFE OF ACETALDEHYDE IN HUMAN ERYTHROCYTE SUSPENSIONS.

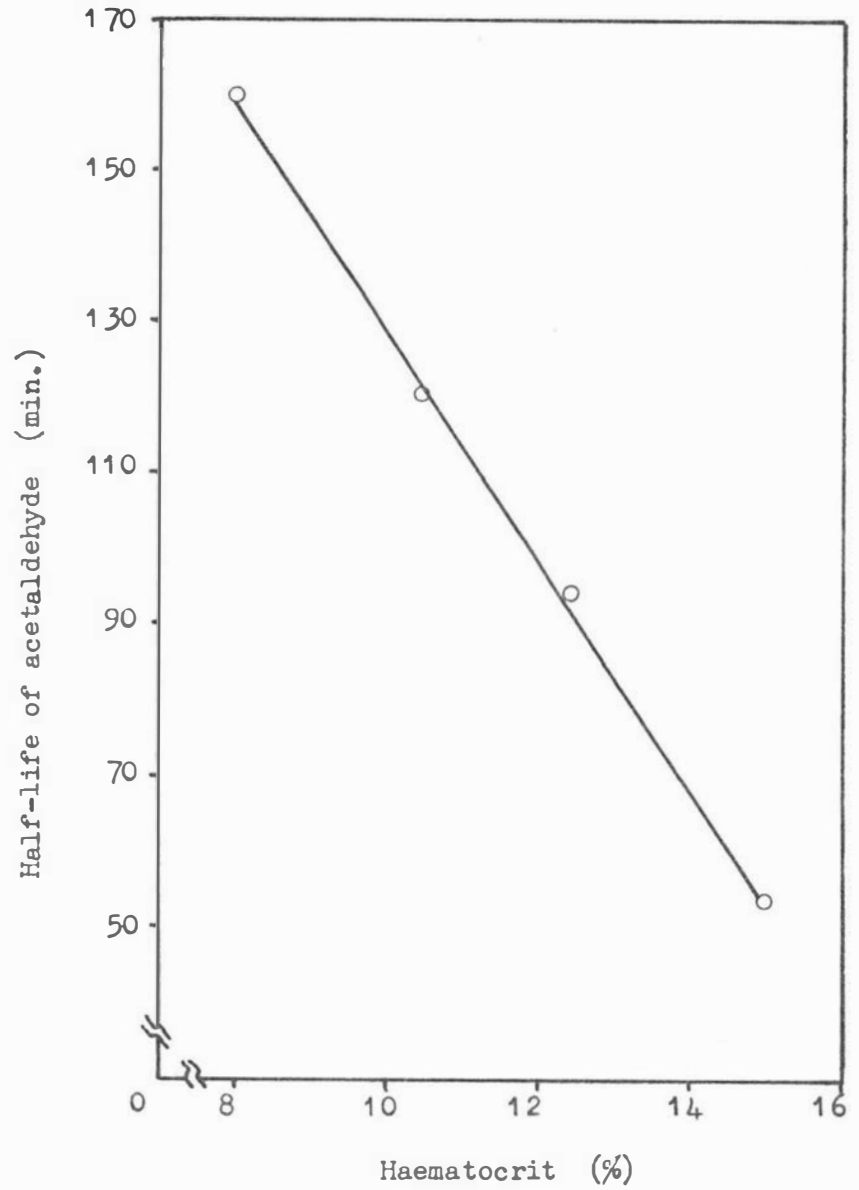

The points in the above figure represent the results of single experiments.

FIGURE 4-12. THE DISAPPEARANCE OF ACETALDEHYDE IN A HUMAN ERYTHROCYTE SUSPENSION.

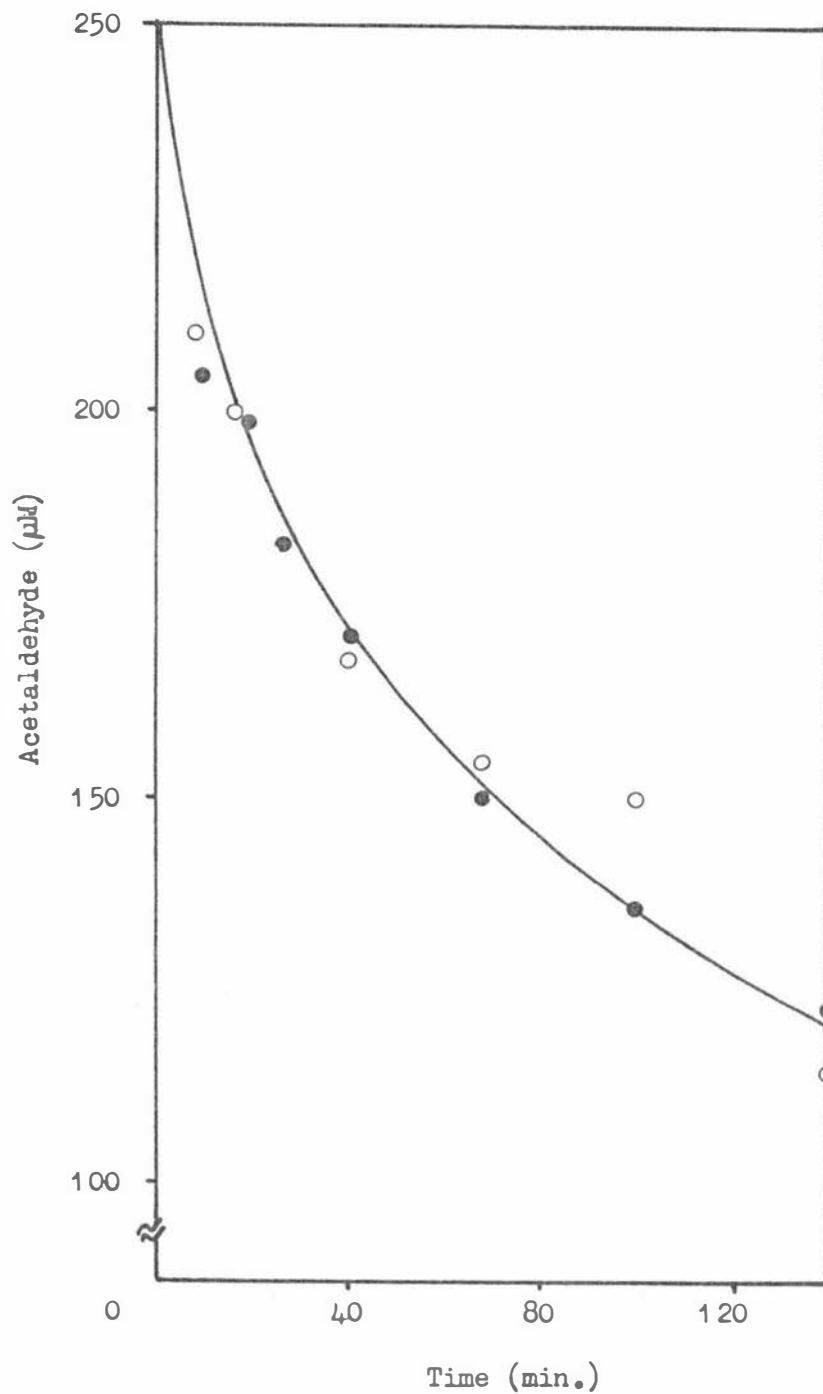

Acetaldehyde in the deproteinized cell suspension (●)  
Acetaldehyde in the cell-free medium (○)

Although the decay mechanisms for acetaldehyde added to whole blood are unknown, it has been suggested by several authors that the removal could be due either to metabolism or the binding of acetaldehyde to blood constituents.

Stotz (1943) observed that acetaldehyde decayed in whole blood and not in plasma. He found that this decay could be inhibited completely for at least 20 min. if blood was kept in an ice-bath and it was suggested that cellular metabolism was responsible. Tungstic acid deproteinization of blood was also found to inhibit the acetaldehyde loss completely. No study of the mechanisms involved was made, however. Acetaldehyde has been found to be produced as a product of deoxynucleoside metabolism in human erythrocyte ghosts (Lionetti *et al*, 1964) in vitro. If this production occurs in vivo it would seem likely that blood cells may have some capacity to metabolize the acetaldehyde, preventing the buildup of this toxic compound. Since the distribution of acetaldehyde metabolizing systems is known to be widespread in other mammalian tissues (Deitrich, 1966), it is possible that such a system could also be present in blood cells.

Matthies (1956, 1957a, 1957b, 1958) has studied the reduction of methaemoglobin by various aldehydes including acetaldehyde and considered that this reaction was catalyzed by a  $\text{NAD}^+$ -dependent aldehyde dehydrogenase present in erythrocytes. The physiological significance of such a reaction is, however, unknown. Matthies carried out all of his experiments with red cells treated with  $\text{NaNO}_2$  to ensure that all of the haemoglobin was converted to methaemoglobin. Presumably this treatment would also cause other changes to erythrocytes. The concentrations of aldehydes used were in the millimolar range. No aldehyde oxidation was observed in methaemoglobin-free cells (Matthies, 1957a) and no aldehyde-linked methaemoglobin reduction was observed in red cell haemolysates (Matthies, 1957b). From the present study it has been shown that haemolysis of blood has little effect on the decay of acetaldehyde at the  $20 \mu\text{M}$  level and it is possible that Matthies may have been observing a reaction, possibly non-physiological, which was different to that investigated in this study.

Duritz and Truitt (1964), using initial blood acetaldehyde levels of  $4.5 \text{ mM}$  found, as in this study, that the disappearance of acetaldehyde was temperature dependent. They assumed that the disappearance was enzyme-catalyzed and attempted, unsuccessfully, to inhibit it with  $\text{HgCl}_2$ . However, deproteinization of blood with  $\text{ZnSO}_4 - \text{Ba}(\text{OH})_2$  was found to completely inhibit the decay. No further study of the reaction

mechanism has been reported by these workers.

Malorny et al (1965) studied the disappearance of formaldehyde in blood obtained from humans and dogs and showed that formaldehyde, in concentrations ranging from about 0.2 - 0.8 mM, disappeared very rapidly with a half-life of about 10 min. It was also shown that formic acid was formed almost quantitatively from the formaldehyde. Because this reaction was found to be only partially  $\text{NAD}^+$ -dependent, it was suggested that oxidation of formaldehyde may be occurring partly in the aldehyde dehydrogenase reaction proposed by Matthies (1957a) and partly through a peroxidative reaction involving catalase. The significance of this study in relation to acetaldehyde decay in blood is undefined since formaldehyde was the only aldehyde studied. However, it seems likely, by analogy, that acetaldehyde would be converted to acetic acid. The results of the experiment described in Section 4-3-8 showed that acetaldehyde was converted, quantitatively, to a soluble non-volatile product which is probably acetate.

Freundt (1970), using initial acetaldehyde concentrations of between 0.45 and 2.3 mM has studied acetaldehyde disappearance in different blood fractions of humans, dogs, rabbits and pigs. The major sites of acetaldehyde removal were found to be the erythrocytes and leucocytes with negligible acetaldehyde decay occurring in plasma. Exponential decay was observed in whole blood and the cellular fractions of blood. These results support those obtained in the present study with much lower acetaldehyde concentrations being used. Freundt (1968) also found that 3-amino-1,2,4-triazole, an effective catalase inhibitor, did not affect the disappearance of acetaldehyde, suggesting that catalase is probably not responsible for the reaction. This is contrary to the views proposed by Malorny et al (1965). Freundt (1970) showed that acetaldehyde disappeared in human blood with a half-life of 59 min. and in rabbit blood with a half-life of about 23 min. These times are much greater than those found in the present study. However, no incubation temperature was reported by Freundt. The high half-life values obtained may have been due at least in part to the use of low incubation temperatures.

The observed quantitative conversion of acetaldehyde to a soluble non-volatile product in blood (see Section 4-3-8) makes unlikely the possibility of acetaldehyde binding irreversibly to protein, at least when acetaldehyde is added to blood in the concentrations used for this study. The results do not rule out the possibility of acetaldehyde binding irreversibly to a soluble compound which is not precipitated by

PCA. However, if such a reaction occurs during the disappearance of acetaldehyde, the unidentified compound would have to exist almost exclusively in the cellular fraction of blood since acetaldehyde disappearance has been shown not to occur to any appreciable extent in plasma. Evidence for the reaction of acetaldehyde in vivo with soluble compounds containing sulphhydryl groups has been reported (Ammon et al, 1971; Sprince et al, 1975; Nagasawa et al, 1975; Nagasawa et al, 1977) and the in vitro acetaldehyde disappearance could be due to such a reaction.

However, this seems unlikely since in the experiment performed with labelled acetaldehyde, it would be necessary to postulate that no reaction of acetaldehyde with the hypothetical reactive compound occurred during heating of PCA supernatants which were treated with  $\text{KHCO}_3$ . The pH of these supernatants was the same as the blood pH and the temperature almost the same as that used for the incubation of the blood samples. It would be expected that a simple chemical reaction would continue under these conditions. However, the reaction involved was completely inhibited by PCA precipitation of proteins and did not continue even when the PCA was neutralized. It seems likely therefore that the acetaldehyde disappearance is due to an enzyme-catalyzed conversion.

Contrary to the results obtained in the present study, Gaines et al, (1977) have presented evidence for the irreversible binding of added acetaldehyde to erythrocyte proteins. Human erythrocyte ghosts were incubated at  $4^\circ\text{C}$  with 5 mM and 10 mM acetaldehyde for 30 min. and newly-formed high molecular weight protein was found after the incubation. The amounts increased with increased acetaldehyde concentrations. Using  $^{14}\text{C}$ -labelled acetaldehyde at a concentration of 1 mM, radioactivity was found to be associated with the newly-formed protein fraction and cross-linking of protein similar to that observed with formaldehyde (Fraenkel-Conrat and Olcott, 1946) was suggested. Incubating washed erythrocyte suspensions with 5 mM acetaldehyde for 30 min. at  $4^\circ\text{C}$  was reported to result in 84% of the acetaldehyde being irreversibly bound to red cell protein and evidence for the occurrence of haemoglobin cross-linking was obtained by polyacrylamide gel electrophoresis. These results are in contrast to those obtained in this study. The difference may be explained in part by the fact that Gaines et al used much higher acetaldehyde concentrations (1 - 10 mM) for their experiments and under their incubation conditions little disappearance of acetaldehyde as observed in this study would have been detected.

#### 4-4-2. Stability of acetaldehyde formed in vivo from ethanol.

The rapid disappearance of added acetaldehyde in blood samples containing stable acetaldehyde levels produced from in vivo ethanol metabolism, and the differential effects of temperature on the two 'types' of acetaldehyde suggest that the acetaldehyde formed in vivo may be reversibly bound in such a way that it is not available to react with the acetaldehyde-metabolizing system but can be released by a PCA treatment of blood. Irreversible binding of acetaldehyde to proteins is known to occur at high acetaldehyde concentrations (Mohammad et al, 1949; Schormuller et al, 1968; Gaines et al, 1977) but there is little evidence for a reversible binding taking place.

Machata and Prokop (1971) and Lüben et al (1972) have suggested that acetaldehyde can be bound to erythrocytes and split off by heating at 60°C. The basis for this suggestion was the finding that acetaldehyde formed in vivo could be detected only in the red cell fraction of blood. A gas chromatographic method for acetaldehyde analysis was used and this involved the heating of blood samples to 60°C to obtain a sample of head-space gas enriched with acetaldehyde. Because no allowance was made in their study for the formation of acetaldehyde from ethanol, the results are difficult to interpret and may be misleading.

Freundt (1975) has suggested that acetaldehyde may bind to blood cell protein by the formation of a Schiff's base. However, no direct evidence for this reaction was presented.

Eriksson et al (1977) have found evidence for the reversible-binding of acetaldehyde to rat red blood cells. Allowance was made for the formation of artefact acetaldehyde and the blood used was taken from animals metabolizing ethanol. The blood specimens used would therefore have been similar to the specimens containing acetaldehyde formed in vivo as used in the present study. Acetaldehyde in rat blood was found to be unevenly distributed in the cells and plasma with the acetaldehyde concentration in the plasma decreasing with time when blood samples were stored at 4°C. The decrease was matched by a simultaneous increase in the erythrocyte fraction. Although these findings could not be demonstrated with human blood, there is a possibility that a fixed amount of acetaldehyde might be bound in human blood before samples are withdrawn.

If endogenous acetaldehyde is bound in some way it would seem likely that acetaldehyde added to blood would be similarly bound. This is obviously not the case, at least at low acetaldehyde concentrations, and it seems to be necessary to postulate that the reaction of

acetaldehyde with blood in vivo is different to in vitro reactions. Alternatively, it might be suggested that what appears to be acetaldehyde, formed in vivo, is not acetaldehyde but some other volatile compound capable of producing NADH in the assay system. Support for this possibility could be claimed from the observation that small amounts of 'apparent' acetaldehyde can be detected in blank blood samples taken from subjects who were not metabolizing ethanol. The blank levels were stable in the same way as the levels found in blood from subjects metabolizing ethanol but were almost always much lower than the 'apparent' acetaldehyde measured during ethanol metabolism.

It may be concluded that although added acetaldehyde appears to be rapidly and quantitatively metabolized to a non-volatile compound in human blood, the fate of acetaldehyde produced from ethanol in vivo may not be the same and it seems that this acetaldehyde as it appears in peripheral venous blood may be reversibly bound, presumably to all proteins. If the results of Gaines et al (1977) result from a reaction which occurs in vivo, there is a possibility that some irreversibly bound acetaldehyde may also exist in human blood, provided sufficiently high levels of acetaldehyde are introduced into the blood from the liver.

The initial assumption that the use of plasma analysis or even whole blood analysis for acetaldehyde might result in low recoveries of this compound is probably wrong because it has been shown that no rapid decay of acetaldehyde produced in vivo occurs in human blood up to 20 min. after sampling. For this reason, it was decided to use both plasma and whole blood analysis for acetaldehyde in the study of human acetaldehyde metabolism presented in Section 6 of this thesis. No corrections for acetaldehyde losses were made but it was realized that the 'apparent' acetaldehyde being measured might not represent either 'free' or total blood acetaldehyde.

## SECTION 5

DEVELOPMENT OF A METHOD FOR THE DETERMINATION OF ACETALDEHYDE IN  
HUMAN BREATH SAMPLES.5-1. INTRODUCTION.

As outlined in Section 1, the work described in this section was carried out in order to obtain estimates of pulmonary blood acetaldehyde levels without direct blood sampling.

Previous methods for the determination of acetaldehyde in breath have involved gas chromatography (Freund and O'Hollaren, 1965; Fukui, 1969; Redmond and Cohen, 1972; Forsander and Sekki, 1974) but because the sensitivity of the enzymic assay methods described in Section 2 of this thesis was found to compare favourably with that of a commonly used gas chromatographic (GC) method (see Section 2-5) it was decided to adapt these methods for the assay of acetaldehyde in breath.

The collection of breath samples for acetaldehyde assay has been carried out either by bubbling breath through ice-cold water traps (Forsander and Sekki, 1974) or by collecting breath in gas-tight containers from which smaller gas samples could be taken for analysis (Freund and O'Hollaren, 1965; Fukui, 1969; Redmond and Cohen, 1972). No concentration of the acetaldehyde in these samples was possible and the sensitivity of the GC methods was therefore restricted either by the size of the sample collected or by the size of the sample injected onto the gas chromatograph.

The rapid reaction of acetaldehyde with semicarbazide at neutral or alkaline pH, the non-volatility and stability of the semicarbazone derivative and the efficiency and ease of regeneration of acetaldehyde from this derivative (see Appendix I) suggested that trapping of breath acetaldehyde with semicarbazide might be an effective way of obtaining a breath sample which could not only be stored without risk of acetaldehyde losses but which could also be concentrated by evaporation of a solution containing the non-volatile acetaldehyde derivative. In this way, sensitivity might be increased without the need to increase the sample size.

After acidifying the acetaldehyde semicarbazone breath samples, regeneration and distillation of the acetaldehyde took place in one step

using the automated continuous-flow distillation system adapted for blood acetaldehyde assays.

No measurement of breath acetaldehyde levels had previously been attempted in this laboratory so the actual levels which might be obtained in the study were unknown. It was therefore assumed, for the purposes of setting up an assay method, that the quantities of acetaldehyde in human breath quoted by Freund and O'Hollaren (1965) would be similar to those obtained in this study. The range of breath acetaldehyde concentrations measured by these workers was about 2 - 20 nmoles/100ml of breath (alveolar air) after subjects had consumed an oral ethanol load of 0.87g/kg body weight. Since it was intended to use similar ethanol loads for the experiments in this study, a range of standards similar to the range measured by Freund and O'Hollaren (1965) was chosen for the initial experiments described in this section.

## 5-2. METHODS AND RESULTS.

### 5-2-1. Assay of acetaldehyde in simulated breath acetaldehyde traps.

It was calculated that if the acetaldehyde present in breath samples of 1 litre, containing 2 - 20 nmoles per 100 ml was trapped as the semicarbazone and concentrated to a total volume of 20 ml, the range of acetaldehyde semicarbazone concentrations in the concentrated samples would be 1 - 10  $\mu$ moles/l. Assuming complete regeneration of the acetaldehyde, this range would be the same as that used for the preparation of the blood acetaldehyde standard curve. It was therefore decided that determination of breath acetaldehyde could be achieved with sufficient sensitivity provided breath samples could be concentrated fifty-fold and a high and constant regeneration efficiency could be obtained over the whole range of standards. In order to determine the efficiency of regeneration, breath acetaldehyde traps were prepared containing acetaldehyde added directly to the traps and samples from these traps were assayed after concentration.

The acetaldehyde trapping solution used for this and all other experiments involved in the determination of breath acetaldehyde concentrations was based on the reagent used by Burbridge *et al* (1950) for the spectrophotometric assay of acetaldehyde, containing the following reagents dissolved in distilled water to a total volume of 500 ml.

$\text{NaH}_2\text{PO}_4 \cdot 2\text{H}_2\text{O}$ , 2.337g;  $\text{Na}_2\text{HPO}_4$ , 4.975g;

Semicarbazide hydrochloride, 0.372g.

Aliquots of standard acetaldehyde solutions were added directly to 50 ml volumes of the above solution in duplicate to give standards in the range 0 - 20 nmoles/100 ml of breath, assuming that all the acetaldehyde in 1 litre of breath would be collected. These samples were then rotary evaporated to a volume of 20 ml at a temperature of between 40 and 50°C.

Aqueous standards containing the same acetaldehyde concentrations as the concentrated traps (i.e. 0 - 10  $\mu$ moles/l) were prepared as well.

For the assay, 1.5 ml aliquots of all simulated samples and standards were mixed in 2 ml Auto Analyzer cups with 0.2 ml of 5M  $H_2SO_4$ . The acid was added to hydrolyze the semicarbazone and release the acetaldehyde. Acid was added to the standards as well so that a correction for the dilution of the samples by the acid would be unnecessary. The acidified samples and standards were then assayed for acetaldehyde in the normal way, using the semi-automated procedure described in Section 2.

The results obtained for this experiment are shown in Fig. 5-1. By using the methods described above, it was found that the recovery of acetaldehyde from the semicarbazone derivative compared with aqueous standards was satisfactory. The variations between duplicates were no greater than those obtained in the blood acetaldehyde assay method and recoveries of acetaldehyde from the samples were constant over the whole range of standards and almost quantitative (96%). The high recovery from simulated samples compared with aqueous standards indicated that acetaldehyde losses in the concentration and hydrolysis steps were negligible. The high blank level of acetaldehyde in the simulated samples indicated some contamination of the reagents used in the trapping solution. However, since this blank level was constant, no correction was needed if the breath samples were collected in the same trapping solution used for the preparation of standards. The use of a standard curve prepared from simulated samples eliminated the need to correct for both the blank level of acetaldehyde in the traps and the regeneration efficiency.

The results of these experiments showed that the low levels of acetaldehyde expected to be present in human breath could be concentrated and assayed with satisfactory sensitivity and reproducibility. However, before the method could be used for the assay of actual breath samples it had to be shown that breath acetaldehyde could be trapped efficiently and reproducibly in the semicarbazide trapping solution.

FIGURE 5-1. COMPARISON OF STANDARD CURVES OBTAINED BY ASSAYING SIMULATED BREATH ACETALDEHYDE TRAPS AND AQUEOUS ACETALDEHYDE STANDARDS.

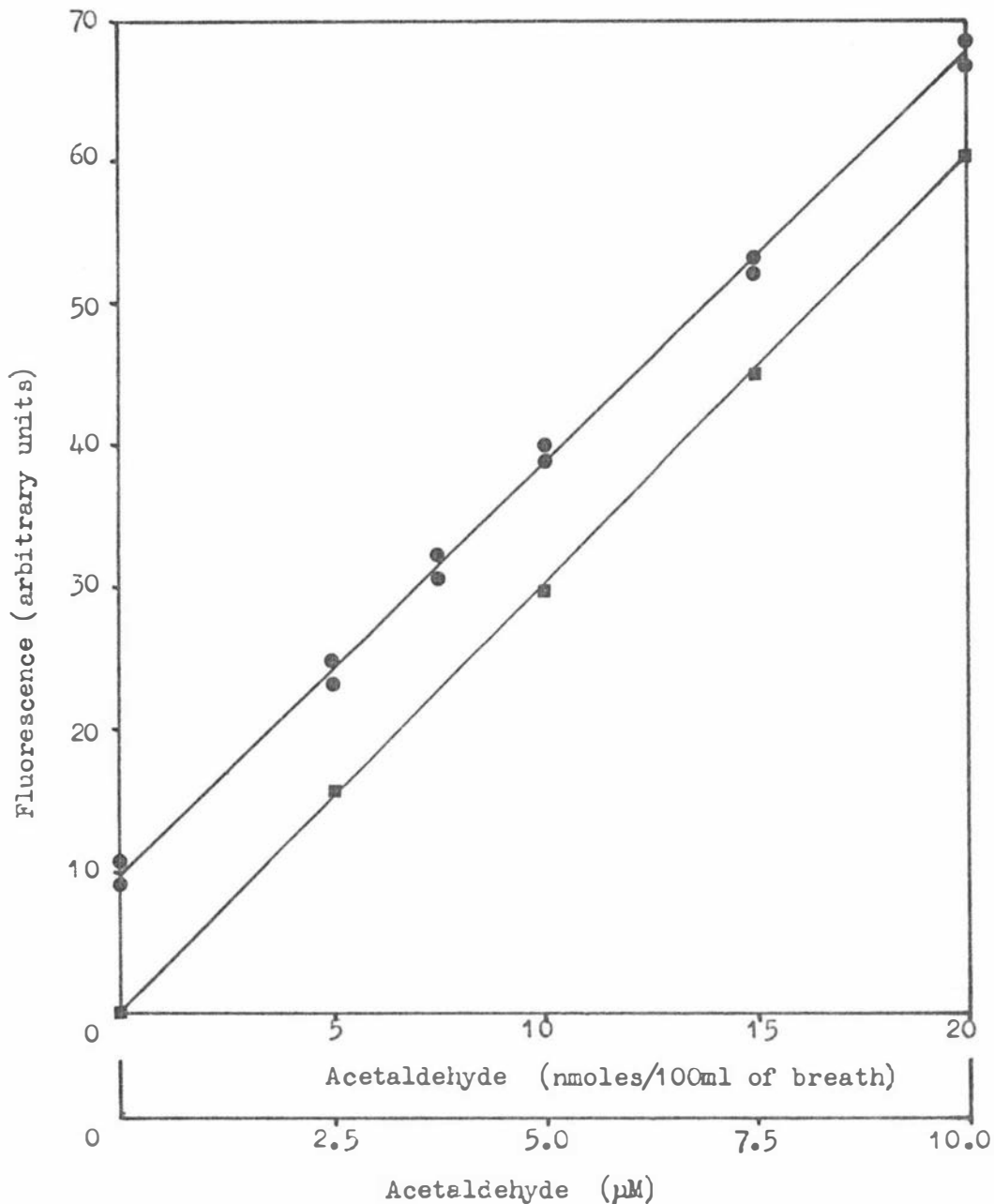

Samples of simulated breath acetaldehyde traps (●), and standard acetaldehyde solutions (■), were prepared and assayed as described in Section 5-2-1. Single determinations of the aqueous standard solutions were made while simulated trap samples were assayed in duplicate.

### 5-2-2. Trapping of acetaldehyde present in simulated breath samples.

As a first step towards measuring the trapping efficiency of the buffered semicarbazide solution with actual breath samples it was decided to measure this efficiency with simulated samples. These were used first to determine reproducibility and efficiency of trapping since it was not known at this stage whether actual breath samples taken over a period of time from a subject metabolizing ethanol would be constant with respect to acetaldehyde concentrations. To determine reproducibility of trapping, a device was required which would produce air samples containing constant amounts of acetaldehyde so that any variations in acetaldehyde assayed in the traps would have been due only to variations in trapping efficiency or distillation efficiency in the assay itself.

A device designed for the production of air samples containing constant amounts of ethanol had been produced commercially for the standardization of breath alcohol testing equipment (The MK IIA Breath Alcohol Simulator<sup>1</sup>. See Fig. 5-2 for illustration) and was available in the laboratory. This device is designed to hold 500 ml of an ethanol solution at a fixed temperature of 34°C. Samples of ethanol vapour which are in equilibrium with the aqueous solution at this temperature are obtained from the simulator through an exit tube by forcing air into the ethanol solution through an inlet tube which is submerged in the ethanol solution. The temperature of 34°C, used for the equilibration of air with the aqueous ethanol sample, has been normally taken as a mean value for the temperature of expired human alveolar air. The blood:breath partition ratio for ethanol is temperature dependent and it is important to maintain the temperature as constant as possible (Harger et al, 1950a). The concentration of ethanol used in the simulator is normally set at an equivalent blood ethanol concentration and the simulated breath samples are used as standards for determining blood ethanol concentrations. To determine the correct ethanol concentration, the partition ratios for ethanol in gas samples equilibrated with both blood and water are required and may be obtained from the literature. However, these partition ratios were not available for acetaldehyde and it was therefore not possible to prepare aqueous acetaldehyde solutions equivalent to blood acetaldehyde solutions. It was assumed that there would be little difference between blood and water with respect to the liquid:air partition ratio of acetaldehyde, and aqueous acetaldehyde solutions covering the maximum concentration range expected in human

---

1. Smith and Wesson Electronics Co., Eatontown, New Jersey, U.S.A.

FIGURE 5-2. APPARATUS USED TO PRODUCE AND TRAP SIMULATED BREATH ACETALDEHYDE SAMPLES.

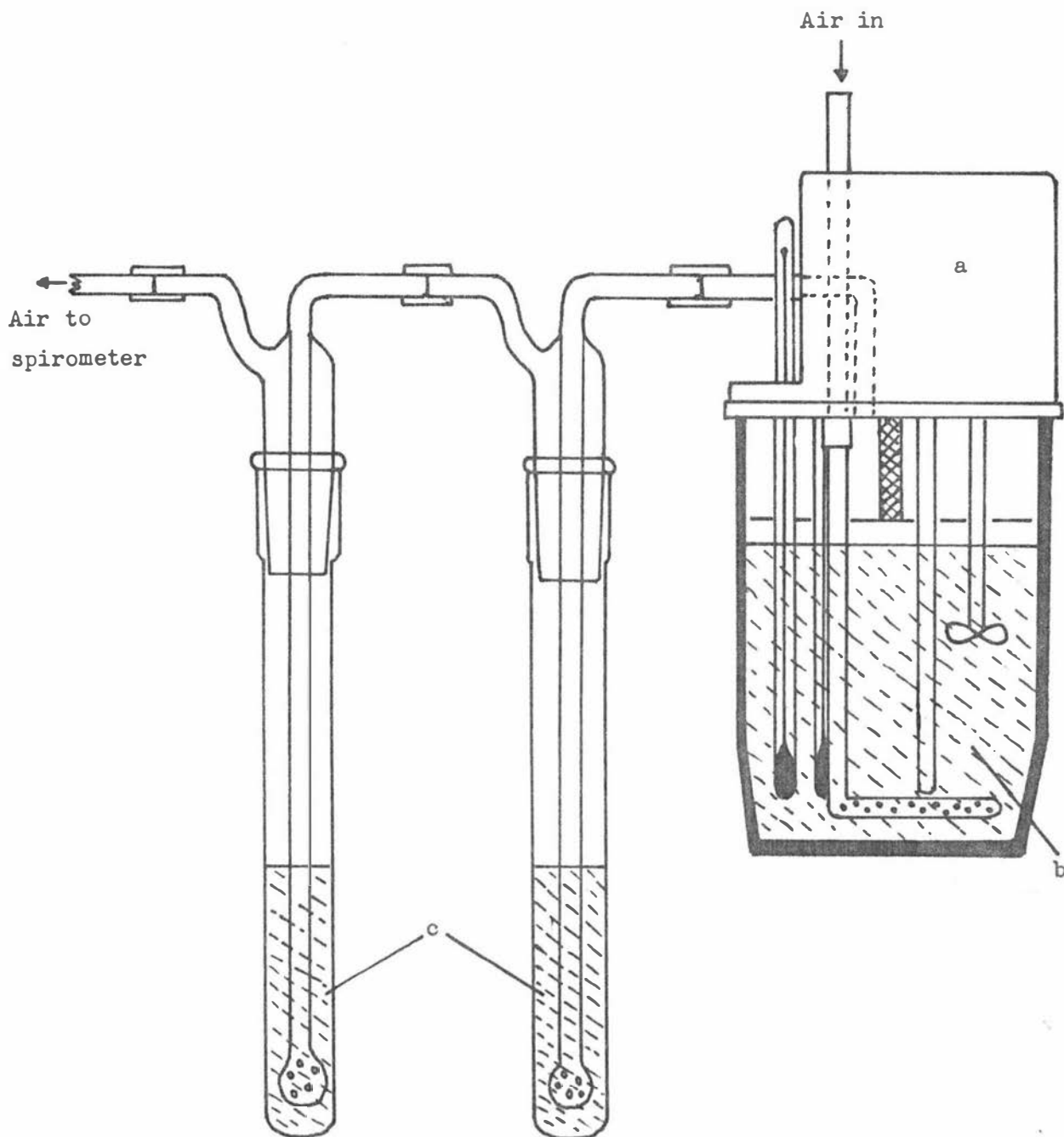

KEY

- a. Smith and Wesson MK IIA breath alcohol simulator.
- b. Standard acetaldehyde solution.
- c. Buffered semicarbazide solution.

The above figure is a half-scale drawing.

blood were used in the simulator for the experiment described below. Since the partition ratio for ethanol distributed at equilibrium between air and blood is only a factor of 1.25 larger than that for ethanol distributed between air and water (Harger et al, 1950a), it was thought that the above assumption would result in the production of simulated breath acetaldehyde samples which would be closely similar to samples equilibrated with blood. Solutions of acetaldehyde in blood could not be used for the simulations because the rapid loss of acetaldehyde shown to occur in human blood would have made production of multiple air samples containing the same amount of acetaldehyde impossible.

For the breath acetaldehyde simulations, the following procedure was followed.

Volumes of aqueous acetaldehyde solutions (500 ml) in the concentration range 10 - 50  $\mu\text{M}$ , plus blank solutions (distilled water only), were placed in the breath alcohol simulator and the temperature raised to 34°C. Air was blown through the acetaldehyde solutions at a rate of about 50 ml/sec. and acetaldehyde in the air was trapped by passing the air through two separate 50 ml aliquots of the buffered semicarbazide solution described in Section 5-2-1. The trapping solution was kept ice-cold in gas bubbler tubes as shown in Fig. 5-2. Two gas bubblers were used in series in order to determine the trapping efficiency of the system. The volume of air passed through the bubblers was  $1.00 \pm 0.05$  litres and was measured by connecting the outlet of the second bubbler tube to a spirometer. Only two simulations were carried out with each 500 ml volume of acetaldehyde solution before it was discarded to avoid significant decreases in the concentrations of the aqueous acetaldehyde solutions which could have occurred as a result of multiple simulations. After the simulations were performed, the 50 ml trap samples were rotary evaporated to 20 ml at 50°C and aliquots of the concentrated samples were assayed after mixing with acid as described in Section 5-2-1. Fluorescence readings obtained by assaying the concentrated trap samples were converted to 'breath' acetaldehyde concentrations using a standard curve prepared by adding known amounts of acetaldehyde to 50 ml aliquots of the trapping solution and treating these samples in the same way as the simulated breath samples.

#### 5-2-2-1. Acetaldehyde trapping efficiency.

Using aqueous acetaldehyde solutions in the simulator containing 10, 30 and 50  $\mu\text{M}$  acetaldehyde, five simulations were performed with

each concentration. The percentage of the total trapped acetaldehyde which was present in the second trap was found to range from 2 - 5%. If only one trap had been used, the mean trapping efficiency for this trap would have been 97%. The high values showed the effectiveness of the semicarbazide traps.

#### 5-2-2-2. Reproducibility and linearity of simulated breath samples.

The results plotted in Fig. 5-3 represent simulated breath acetaldehyde concentrations calculated from the concentration of acetaldehyde in the first trap only with no correction for the trapping efficiency. It was found that as a result of the temperature differential between the air entering the traps from the simulator, and the air in the spirometer (a difference of 9 - 13°C depending on room temperature), the volumes of air measured as 1 litre at room temperature were actually 1.03 - 1.04 litres at 34°C. This may be calculated using Charles's Law. If no corrections are made for the temperature differential or the trapping efficiency, the introduced errors compensate each other to the extent that a maximum error of only  $\pm 2\%$  is introduced at the sample collection stage.

Fig. 5-3 shows that there is a linear relationship between the concentration of acetaldehyde in aqueous solution and air equilibrated with the aqueous solution within the range of concentrations used. This indicated that the breath alcohol simulator was as useful for the simulation of breath acetaldehyde samples as for breath alcohol samples. The variation of replicate samples is only slightly greater than that obtained when aqueous acetaldehyde standards are assayed. With aqueous standards, a maximum range of  $\pm 2$  fluorescence units was obtained when assaying replicate samples, while the assay of replicate simulated breath acetaldehyde samples resulted in a maximum range of  $\pm 3$  fluorescence units, representing a maximum error for a single breath acetaldehyde determination of  $\pm 0.75$  nmoles/100 ml. It is likely however, that the error in the measurement of lower breath acetaldehyde levels (0 - 5 nmoles/100 ml) is not as great as that associated with higher levels (15 - 26 nmoles/100 ml). This possibility is suggested by the much smaller variability in replicate blanks and samples produced using a 10  $\mu\text{M}$  acetaldehyde solution in the simulator.

#### 5-2-3. Determination of the efficiency of trapping acetaldehyde from actual breath samples.

Breath samples of 1 litre were trapped using the double trapping

FIGURE 5-3. REPRODUCIBILITY OF SIMULATED BREATH SAMPLES.

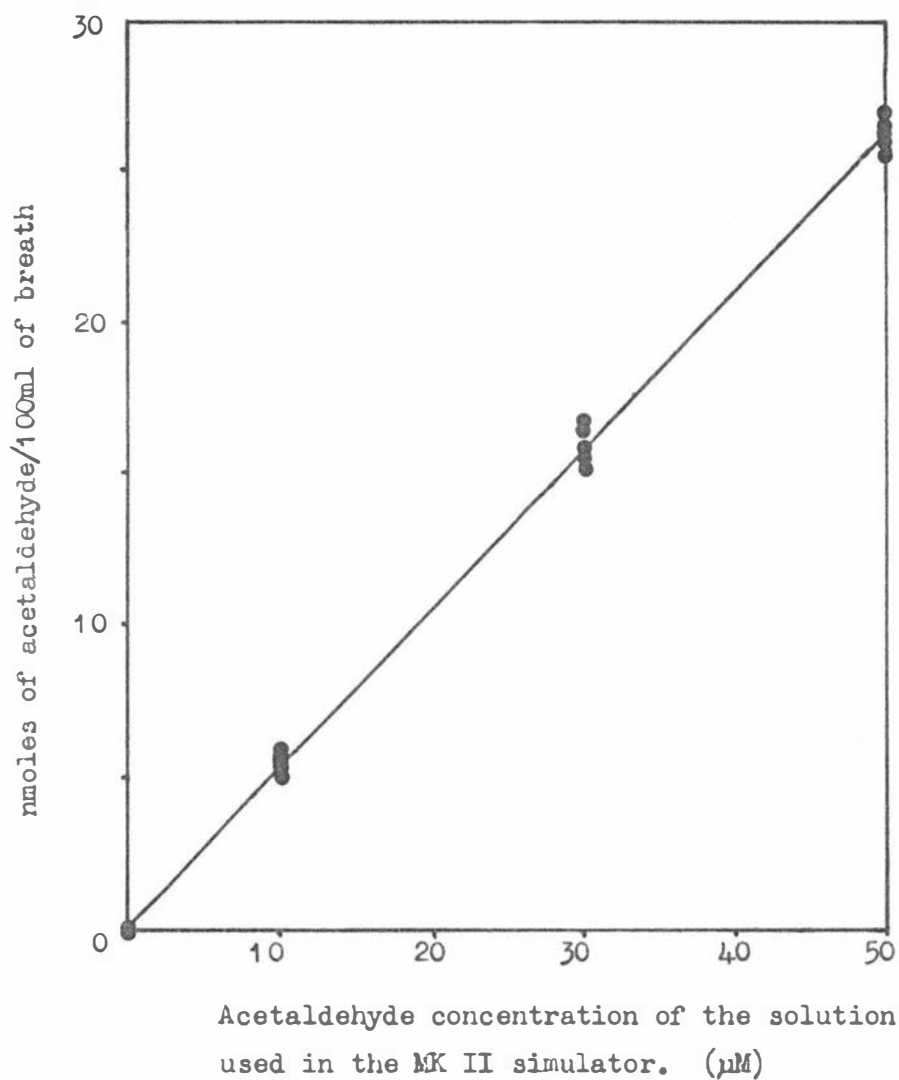

$n = 5$  for each acetaldehyde concentration.

FIGURE 5-4. SAMPLE PUMPING UNIT USED FOR THE AUTOMATIC ACIDIFICATION OF BREATH ACETALDEHYDE SAMPLES.

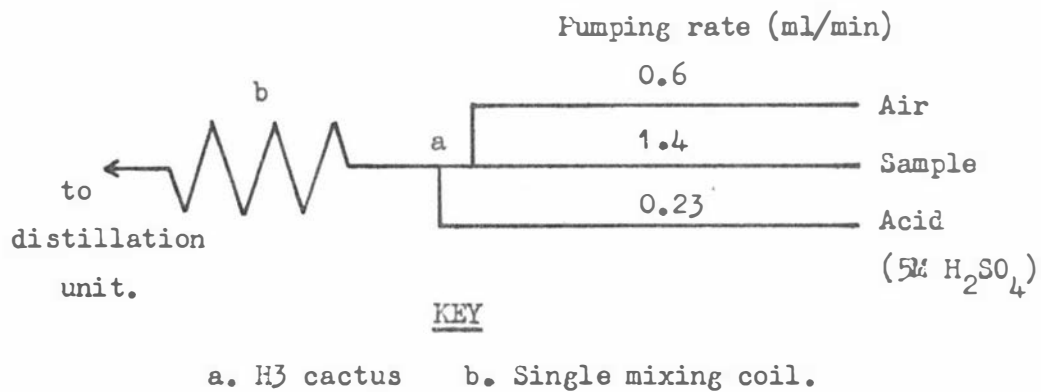

TABLE 5-1.

## EFFICIENCY OF TRAPPING OF BREATH ACETALDEHYDE.

<u>Sample No.</u>	Breath acetaldehyde concentration. (nmoles/100 ml)		% of total trapped acetaldehyde in trap 1.
	<u>Trap 1.</u>	<u>Trap 2.</u>	
1	10.0	0.2	98
2	6.0	0.2	97
3	6.4	0.2	97
4	6.4	0.3	95
5	6.4	0.1	98

Mean trapping efficiency = 97%

See Section 5-2-3 for experimental details.

system employed for the experiment described in Section 5-2-2. and were obtained from an adult male subject who had consumed an ethanol load (as vodka) of 1g/kg body weight. For each sample the subject voided a measured volume of 2 litres and the third litre of expired air was passed through the acetaldehyde traps. The rate at which the expired air was bubbled through the traps varied but was approximately the same as that used for the simulated breath samples i.e. near 50 ml/sec. The acetaldehyde present in each trap was assayed as described in Section 5-2-2. Before the ethanol load was consumed by the subject a blank breath sample was obtained which when assayed, showed no detectable acetaldehyde. The results obtained are presented in Table 5-1 and show that the mean trapping efficiency for real breath samples when a single trap is used is the same as that obtained with simulated breath samples. This meant that a single trap could be used for actual breath samples, allowing measurements of breath acetaldehyde to be made without the need to apply a correction for trapping efficiency; the error in the calculated concentrations being the same as the error associated with measurements of acetaldehyde in simulated breath samples.

#### 5-2-4. Reproducibility of actual breath samples.

Duplicate breath samples were collected from 24 male subjects who had previously consumed varying quantities of ethanol as beer, or spirits (gin or vodka) with no more than 1 min. elapsing between the taking of the two samples. The blood ethanol levels of the subjects varied between 1 and 24 mM when the breath acetaldehyde samples were taken and were estimated from breath levels of alcohol using a MK IV Intoximeter<sup>1</sup> calibrated to give a direct readout of equivalent blood alcohol concentrations. The breath acetaldehyde samples were collected in a single trap and assayed by the procedure described in Section 5-2-4. The fraction of breath sampled was the first litre of expired air taken after a normal inspiration.

The mean difference between the acetaldehyde concentrations of duplicates was found to be 1.1 nmoles/100 ml, with the maximum and minimum differences being 6.4 and 0.1 nmoles/100 ml respectively. In only three cases was the difference between duplicates greater than the maximum difference which would be expected between duplicate simulated breath acetaldehyde samples i.e. 1.5 nmoles/100 ml. For these three cases the differences were 1.8, 3.8 and 6.4 nmoles/100 ml

---

1. Intoximeters Inc. St. Louis, Mo., U.S.A.

and were probably due to actual changes in breath acetaldehyde concentrations. The results suggest that there are no significant differences between replicates of simulated and actual breath acetaldehyde samples.

#### 5-2-5. Automation of sample acidification.

To avoid the manual addition of acid to samples, which involved the accurate measurement and mixing of fixed volumes of sample and acid, it was decided to automate this step in the assay procedure. The sample/air pumping tubes in the manifold used for the semi-automated assay was replaced with the unit shown in Fig. 5-4. The single mixing coil was included in the sample pumping line to facilitate mixing of the sample with the acid before it reached the distillation system. The pumping tube used for the acid was a standard tygon tube and did not deteriorate after many hours of use. When this system was used it was found to give the same results as those obtained when the samples were acidified manually. The only difference between standard curves produced by assaying a range of simulated breath samples by the two different methods was a small difference in sensitivity which could be accounted for entirely by the difference in dilution of the samples with the acid.

#### 5-2-6. Fully automated breath acetaldehyde assay.

When the fully automated method for the assay of acetaldehyde in blood was found to function satisfactorily, the method was also used for the measurement of breath acetaldehyde. The only changes to the system which were required were (a) replacement of the sample/air pumping tubes with the system illustrated in Fig. 5-2 and (b) extension of the tube carrying the enzyme/ $\text{NAD}^+$ / $\text{K}^+$  solution to correct for the alteration in the sample phasing caused by the presence of the single mixing coil in the sample line. Modification of the fully automated assay system for the assay of blood or breath was simplified by making two enzyme phasing tubes and two separate sampling sections of the manifold which could be readily interchanged.

The fluorescence peaks obtained when analyzing breath samples with the fully automated assay system were similar in shape to those obtained when blood supernatants were analyzed and the maximum variation in the measured acetaldehyde level of aliquots taken from a single concentrated breath sample was found to be  $\pm 0.25$  nmoles/100 ml. This variation was the same as that obtained using the semiautomated assay method.

#### 5-2-7. Stability of samples.

When concentrated samples and standards were stored at 0 - 4°C for up to 5 days, no significant change in acetaldehyde concentration occurred in the samples when compared with the standards. However, storage for much longer periods of time gave variable results.

A number of samples and standards were assayed and stored for a period of seven weeks at -20°C before being reassayed after thawing. The results of this experiment are shown in Table 5-2. Because of the inherent variability of the distillation system employed for the assay of the samples, differences between the measured concentrations of samples before and after storage were expected, however these differences were not expected to be greater than 0.5 nmoles/100 ml since the maximum variation in acetaldehyde assayed in replicate aliquots of the same concentrated breath sample was found to be  $\pm$  0.25 nmoles/100 ml.

Of the acetaldehyde concentrations measured after storage at -20°C, 49% were significantly different to those of the corresponding unstored samples, the maximum differences being an apparent increase of 1.5 nmoles/100 ml and a decrease of 1.7 nmoles/100 ml. These differences were approximately three times higher than expected maximum figures. It was concluded therefore, that concentrated breath samples should not be stored frozen for long periods. The reason for the losses and apparent gains of acetaldehyde in samples which were stored for long periods in the frozen state is unknown.

#### 5-2-8. Determination of the partition ratio of acetaldehyde distributed between blood and air at equilibrium.

Although the methods for the assay of acetaldehyde in both breath and blood which have been developed in this study lack the precision required for the determination of a precise value for the blood:air partition ratio for acetaldehyde, it was decided to attempt to determine this value. No reports of previous attempts to obtain this value could be obtained from the literature and without at least an approximate value for the partition ratio, no estimates of acetaldehyde levels in pulmonary blood could be made from breath acetaldehyde levels.

The blood:air acetaldehyde partition ratio was determined by trapping and assaying air samples in equilibrium with blood containing an initial level of 50  $\mu$ M acetaldehyde and simultaneously measuring the blood acetaldehyde levels. Blood and air samples had to be taken simultaneously because of the rapid rate of removal of acetaldehyde which occurs in blood. The removal of acetaldehyde was found to occur

TABLE 5-2.

STABILITY OF CONCENTRATED BREATH ACETALDEHYDE SAMPLES  
DURING STORAGE AT  $-20^{\circ}\text{C}$  FOR SEVEN WEEKS.

Acetaldehyde concentration before storage. (nmoles/100 ml)	Acetaldehyde concentration after storage. (nmoles/100 ml)
0.0	0.0
4.2	5.0
3.7	5.0
4.0	4.2
4.6	6.1
4.8	4.6
4.9	5.6
3.6	3.5
2.9	3.7
5.4	5.9
4.9	5.2
3.5	4.4
3.5	3.7
3.8	4.6
3.7	4.2
3.5	3.3
3.4	3.5
4.4	3.7
2.7	2.6
3.1	2.9
3.1	3.7
2.9	3.1
3.5	3.5
4.3	3.7
4.1	3.5
3.3	4.0
3.5	2.7
2.6	2.4
4.1	2.6
4.1	2.4
2.7	2.7

The breath acetaldehyde concentrations tabulated above were calculated using standards stored for the same time under the same conditions as the samples.

more slowly in outdated blood-bank blood than in fresh blood. Accordingly, outdated blood-bank blood was used after sufficient plasma had been removed to correct for the volume of anticoagulant added to the original whole blood sample.

A 500 ml sample of blood was placed in the MK IIA breath alcohol simulator and the temperature of the blood was raised to 34°C. When the blood temperature was constant, sufficient acetaldehyde was added in 2.5 ml of water to give an initial blood level of 50  $\mu\text{M}$  and the system was allowed to equilibrate with mixing for about 5 min. After this time, three simulations were carried out as described in Section 5-2-2 using only one trap for each simulated breath sample. While each air sample was being produced and trapped, a small sample of the blood was withdrawn from the simulator (2 - 3 ml) and deproteinized with an equal volume of 1M PCA. Acetaldehyde in the protein-free supernatant of the blood sample was assayed using the semi-automated enzymic assay method and acetaldehyde present in the air traps was determined as described in Section 5-2-2. Six values for the blood:air partition ratio for acetaldehyde were obtained by performing three simulations with each of two 500 ml blood samples containing the same initial level of acetaldehyde.

The results obtained are shown in Table 5-3 and the calculated blood:air partition ratios are compared with the water:air partition ratios for acetaldehyde which were calculated from the data produced in the experiment described in Section 5-2-2. The results given in Table 5-3 show that as the blood level of acetaldehyde decreases, the level of acetaldehyde in air equilibrated with the blood decreases at a similar rate and the partition ratio for acetaldehyde distributed between air and blood at equilibrium at 34°C is not significantly different to that for acetaldehyde distributed between air and water under the same conditions. The variations observed in the measured values for the partition ratios could be simply the result of errors associated with the assay methods.

#### 5-2-9. Dependence of the water:air partition ratio for acetaldehyde on equilibration temperature.

In order to determine whether the water:air partition ratio for acetaldehyde is affected by temperature as is the corresponding ratio for ethanol, simulated breath samples were produced at several different equilibration temperatures using the method described in Section 5-2-2, replacing the breath alcohol simulator with a Dreschel Bottle

TABLE 5-3.

COMPARISON OF THE BLOOD:AIR AND WATER:AIR PARTITION  
RATIOS FOR ACETALDEHYDE AT 34°C.

Simulation No.	Blood [Acetaldehyde] (nmoles/100 ml)	Air [Acetaldehyde] (nmoles/100 ml)	Partition Ratio = $\frac{\text{Blood [Acetaldehyde]}}{\text{Air [Acetaldehyde]}}$
1	2,900	14.0	207
2	2,400	14.0	171
3	2,000	10.5	191
4	3,000	16.0	188
5	2,600	13.5	193
6	2,050	11.0	186

Mean Blood:Air partition ratio = 189

Aqueous [Acetaldehyde] (nmoles/100 ml)	Air [Acetaldehyde] (nmoles/100 ml)	Partition Ratio = $\frac{\text{Aqueous [Acetaldehyde]}}{\text{Air [Acetaldehyde]}}$
1,000	5.3 <sup>a</sup>	189 <sup>a</sup>
3,000	15.3 <sup>a</sup>	196 <sup>a</sup>
5,000	26.6 <sup>a</sup>	186 <sup>a</sup>

Mean Water:Air partition ratio = 190

Range = 174-210

a. Mean of five determinations.

FIGURE 5-5. DEPENDENCE OF THE WATER:AIR PARTITION RATIO FOR ACETALDEHYDE ON EQUILIBRATION TEMPERATURE.

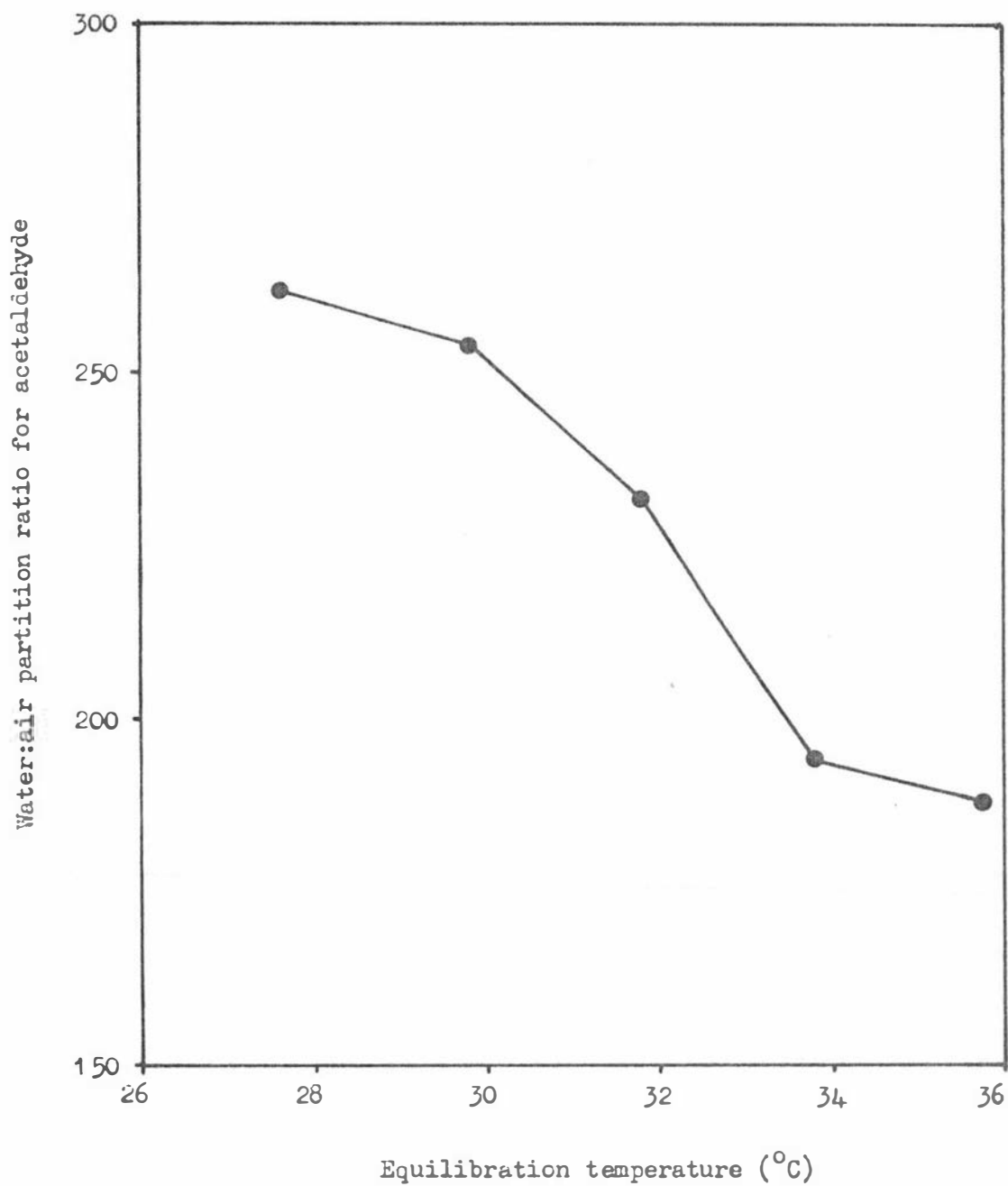

containing 500 ml of a standard 30  $\mu\text{M}$  aqueous acetaldehyde solution and using a single trap. The bottle was placed in a water bath at five different temperatures between 27 and 36°C and when the acetaldehyde solution in the bottle had reached the temperature of the water bath, 1 litre of air was bubbled through the solution. Duplicate simulations were performed in this way at each different temperature and fresh 30  $\mu\text{M}$  acetaldehyde solutions were used for each pair of simulations.

The results of this experiment are shown in Fig. 5-5. The partition ratios shown on the graph were calculated using the means of the measured concentrations of acetaldehyde in the air samples and represent the concentration of acetaldehyde in the aqueous solution divided by the concentration of acetaldehyde in the air equilibrated with it.

#### 5-2-10. Determination of the variation of breath acetaldehyde concentration with the depth of expired air.

The blood:air partition ratio for ethanol varies with temperature (Harger et al, 1950a) and can be used to relate breath ethanol levels to blood levels only if the air has been in equilibrium with the blood. As a result, investigators who wished to determine pulmonary blood ethanol levels from levels of ethanol in breath have placed considerable importance on sampling alveolar air at a fixed temperature in order to obtain breath alcohol samples which have been in equilibrium with pulmonary blood.

At the time this work was proceeding, there had been no published work relating to the effect of breath temperature and/or depth of expiration on the level of acetaldehyde in breath. It was necessary to determine if either of these factors were important in determining breath acetaldehyde levels, before proceeding to measure breath acetaldehyde concentrations in volunteers metabolizing ethanol.

A study was made of the variation in the acetaldehyde concentration between the first, second and third litres of expired air obtained from a subject who had previously consumed an ethanol load of 1g/kg body weight as vodka. The levels of ethanol in the same fractions of breath were also determined so that a comparison could be made between the effect of 'breath depth' on the levels of acetaldehyde and ethanol in expired air.

Beginning 68 min. after ethanol had been consumed, separate breath samples were obtained which were used for the determination of ethanol and acetaldehyde.

After a deep inspiration, the subject held his breath for 2 - 3 sec. then breathed through a tube connected to a valving system used to direct different portions of the expired breath sample either (a) to the atmosphere, (b) to a 1 ml sample loop of a Carle AGC211 gas chromatograph<sup>1</sup> or (c) to a single acetaldehyde trap of the type shown in Fig. 5-2. Breath samples were collected for ethanol analysis immediately after one, two or three litres of air had been expired by the subject and these were passed from the sample loop onto a 150 mm Porapak Q column held at 120°C. Nitrogen flow-rate through the column was 40 ml/min. and the retention time for ethanol was 30 sec. The gas chromatograph was calibrated using the MK IIA breath alcohol simulator containing a standard aqueous solution of ethanol at 34°C. The temperature of the breath as it left the mouth of the subject was measured electronically with a thermistor incorporated into the mouth-piece used by the subject. Breath ethanol levels were corrected to a standard breath temperature of 34°C using the actual recorded breath temperature and the data of Harger *et al* (1950a). The ethanol levels in simulated breath ethanol samples were recorded as peaks by means of a chart recorder and the heights of these peaks were reproducible to  $\pm 0.5\%$ .

Acetaldehyde present in the first, second and third litres of expired air was trapped and assayed using the methods described in Section 5-2-2. Sampling of the different fractions of breath was carried out so that no more than 2 min. separated the collection of each of the three samples. Eight sets of three samples were taken in this way over a period of 73 min. In addition, six 1 litre samples of mainly tidal breath were trapped for acetaldehyde analysis. Such samples were made up of a total of four or five 200 - 250 ml volumes of breath which were delivered after normal inspirations.

The results of this experiment are shown in Fig. 5-6 and indicate that although the levels of breath ethanol are significantly affected by the fraction of expired air sampled, the level of acetaldehyde is not. If all the breath samples were identical, the maximum expected difference between measured acetaldehyde levels in the samples would be 1.5 nmoles/100 ml (see Section 5-2-2). Only the third set of three samples exceed this range. The close similarity between the levels of acetaldehyde measured in tidal air with those measured in the third

---

1. Carle Instruments Inc. Fullerton, California, U.S.A.

FIGURE 5-6. VARIATION OF BREATH ACETALDEHYDE AND ETHANOL CONCENTRATIONS WITH THE DEPTH OF EXPIRED AIR.

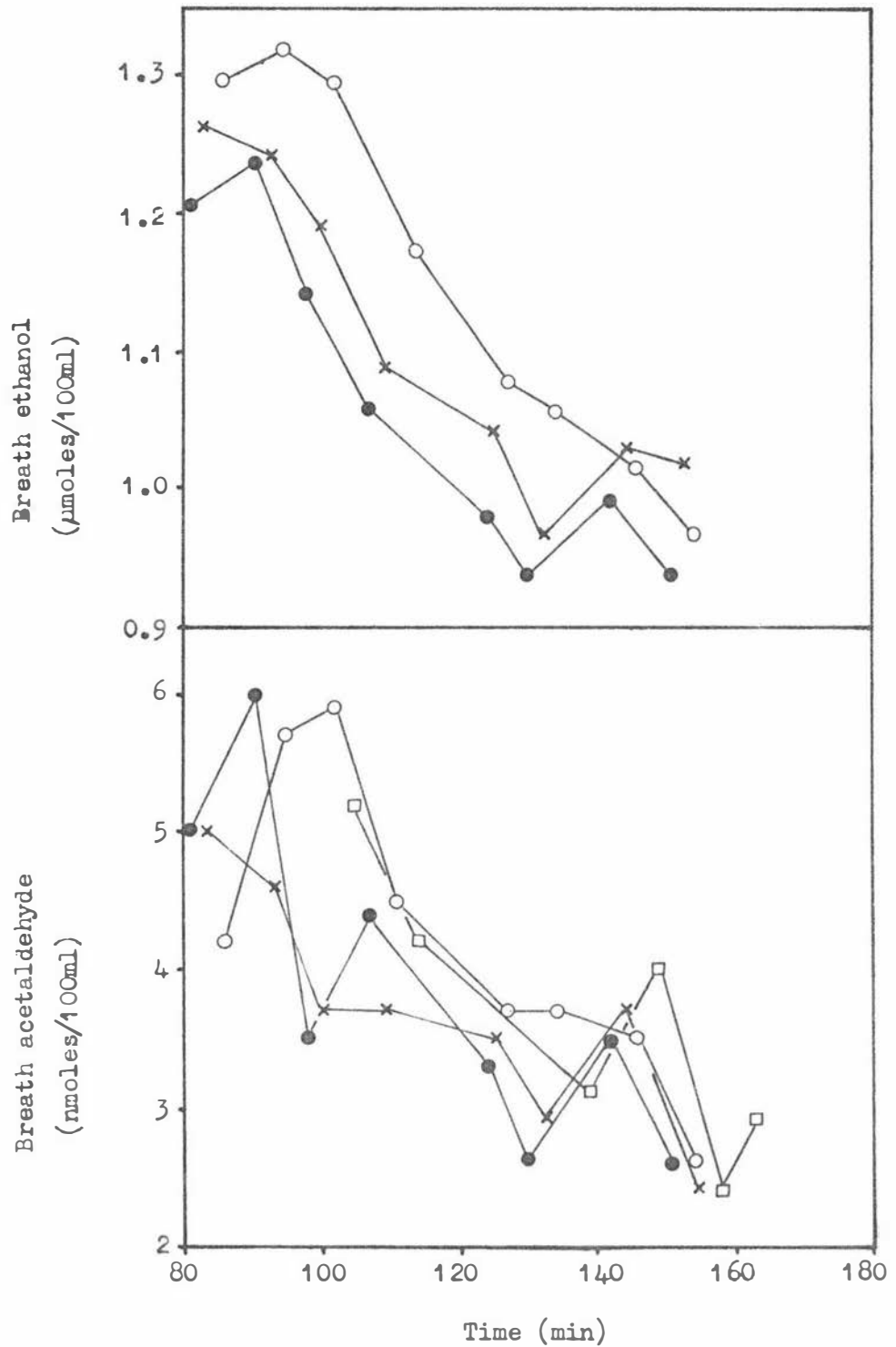

Ethanol and acetaldehyde concentrations in the first (●), second (\*), and third (○) litres of expired air and the concentration of acetaldehyde in tidal air (□) were determined as described in Section 5-2-10. All samples were taken from a single subject during metabolism of a 1g/kg dose of ethanol.

litre of expired air which may be regarded as alveolar, suggests that all fractions of expired air may contain the same level of acetaldehyde and it may therefore be unnecessary to sample alveolar air when assaying breath acetaldehyde. This appears to be true even though the temperature of the expired breath samples varied from a minimum of  $32.0^{\circ}\text{C}$  (tidal air) to a maximum of  $34.5^{\circ}\text{C}$  (alveolar air). The temperatures of the breath samples used for alcohol analysis were  $33.3 \pm 0.3^{\circ}\text{C}$ ,  $33.7 \pm 0.3^{\circ}\text{C}$  and  $34.0 \pm 0.5^{\circ}\text{C}$  for samples taken after expiration of 1, 2 and 3 litres respectively. The above figures represent means and standard deviations for eight determinations.

5-2-11. Level of assayable aldehydes in spirits consumed by human volunteers.

Since the enzymic assay method will detect any volatile aldehydes present in breath which will (a) react with aldehyde dehydrogenase and (b) form a stable semicarbazone derivative which can be readily regenerated in the presence of acid, the method is not specific for acetaldehyde. It was considered necessary therefore, to determine whether the spirits administered to human subjects involved in this study contained any volatile aldehydes as congeners and if the level of these compounds was sufficiently high for them to be detected in breath samples.

By assaying diluted samples of gin and vodka using the method employed for blood samples it was found that the total level of assayable aldehydes in these spirits was too low to produce detectable aldehyde levels in breath after consumption of these spirits in the quantities employed for the experiments described in this section and Section 6. The highest level of assayable aldehydes was found in vodka at  $81 \mu\text{M}$ . Dilution of the vodka (approximately 6.5 M ethanol) in the body when a standard dose of  $1\text{g}/\text{kg}$  was used was shown to result in an initial blood ethanol level of approximately  $22 \text{mM}$  (see Section 6). If it is assumed that the volatile aldehyde level of vodka is diluted to the same extent, and that no metabolism of the aldehyde(s) occurs, then the expected blood level of volatile aldehydes would be about  $0.25 \mu\text{M}$ . Using the calculated blood:air partition ratio for acetaldehyde, this blood level may be calculated to give a maximum breath aldehyde level of no more than about  $0.12 \text{nmoles}/100 \text{ml}$ . Although this level may be detected by the enzymic assay method described in this section it is negligible compared to the levels normally determined (see Section 6).

It may be assumed therefore, that when the enzymic breath acetaldehyde assay method is employed with subjects consuming gin or vodka in doses of up to 1g/kg, the only aldehydes measured in the breath of these subjects must be derived from the metabolism of ethanol. Since the only aldehyde produced in this way is acetaldehyde, for the purposes of this study the assay may be regarded as specific.

### 5-3. DISCUSSION.

The assay of breath acetaldehyde by the methods described in this section is probably not as convenient as GC methods which have been described previously (Frøund and O'Hollaren, 1965; Fukui, 1969; Redmond and Cohen, 1972; Forsander and Sekki, 1974), the evaporation of the acetaldehyde traps being a time-consuming process. However, the enzymic assay eliminates the problems associated with GC estimations of acetaldehyde (see Section 2-1) and the sensitivity of the method described is similar to that of the GC method of Redmond and Cohen (1972) which has been reported to be capable of detecting a minimum breath acetaldehyde concentration of 0.25 nmoles/100 ml. The enzymic assay would thus appear to be ideally suited to the measurement of human breath acetaldehyde levels.

Some of the analytical problems associated with the measurement of acetaldehyde in blood samples are not encountered with breath samples. The most important of these problems, the production of acetaldehyde from ethanol during sample preparation, does not occur and the storage period for breath samples can be longer than that for blood supernatant samples, presumably because the semicarbazone derivative of acetaldehyde is more stable than acetaldehyde itself.

The absence of a significant difference between the blood:air and water:air partition ratio for acetaldehyde was unexpected and suggests that there is an even distribution of acetaldehyde between the liquid and solid phases of blood. The situation is different for ethanol and the blood:air partition ratio for ethanol is correspondingly lower than that for water:air (Harger et al, 1950a). If acetaldehyde is evenly distributed throughout the solid and liquid phases of blood, it may explain why it is unnecessary to apply a correction factor for blood solid content when determining the recovery of acetaldehyde from blood compared to aqueous standards (see Section 2-4-4).

Since the water:air partition ratio for acetaldehyde is dependent on the equilibration temperature it may be assumed that the blood:air ratio varies with temperature in a similar way. It is therefore

important to know the temperature at which the equilibration of acetaldehyde with air and blood occurs, if a partition ratio is to be applied to breath acetaldehyde concentrations to estimate pulmonary blood levels of acetaldehyde. Initially, this temperature would be the temperature of the lungs. However, for ethanol, reequilibration of the substance from alveolar air with water in the upper respiratory tract is believed to occur (Wright et al, 1975) resulting in an equilibration at a lower temperature, i.e. that of expired alveolar air which is normally taken to be  $34^{\circ}\text{C}$ . If tidal air is expired, the breath temperature is lower than  $34^{\circ}\text{C}$  and the reequilibration takes place at a lower temperature resulting in lower concentrations of breath ethanol. If this situation also applies to acetaldehyde then the partition ratio determined at  $34^{\circ}\text{C}$  may be used to calculate pulmonary blood acetaldehyde levels, provided alveolar air is sampled. However, the inability to determine significant differences in acetaldehyde concentration between tidal and alveolar air which were at different temperatures presents some doubt as to whether acetaldehyde in the breath behaves in a similar manner to ethanol. The reason for the apparent lack of effect of depth and temperature of expired air on breath acetaldehyde concentration is unknown but may be partly due to large fluctuations in breath acetaldehyde concentrations obscuring any differences which may result from the temperature or the extent of equilibration of the breath acetaldehyde sample. These fluctuations may be caused by (a) errors associated with the assay method and/or (b) actual fluctuations of the levels of acetaldehyde present in the breath occurring during the time replicate samples were taken.

For the purposes of this study it was decided to measure breath acetaldehyde levels in alveolar air and use the blood:air partition ratio determined at  $34^{\circ}\text{C}$  to calculate pulmonary blood acetaldehyde levels.

## SECTION 6

ACETALDEHYDE LEVELS IN THE BREATH, WHOLE VENOUS BLOOD AND PLASMA  
OF HUMAN SUBJECTS METABOLIZING A STANDARD DOSE OF ETHANOL.6-1. INTRODUCTION.

The main objectives in carrying out the experiments described in this section were outlined in Section 1. Some additional areas which were investigated are discussed in this section.

The work of Crow (1975), on levels of acetaldehyde in peripheral venous blood of human subjects metabolizing ethanol, indicated that plasma levels of acetaldehyde were lower than the levels found in whole blood or red-cell samples. The reason for this finding is not known but may have been related partly to the fact that no correction was made for the production of acetaldehyde in ethanol-containing blood samples during deproteinization. As this occurs to an appreciable extent only in the presence of red-cells (see Section 3), it would be expected that this effect alone might be responsible for the observed differences in plasma and whole blood acetaldehyde levels.

Since no other study on human blood similar to that of Crow (1975) has been carried out, it was decided to repeat this work employing the necessary corrections for the production of acetaldehyde as an artefact to determine if a significant plasma/whole blood difference in acetaldehyde level does exist. A study of this type was originally thought to be impossible because of the rapid disappearance of acetaldehyde which was believed to occur during the processing time required for a plasma sample to be obtained. However, in the study described in Section 4, this rapid disappearance was shown to be confined to added acetaldehyde and the endogenous acetaldehyde levels of whole blood samples taken from subjects metabolizing ethanol were shown to be stable over a period of up to 20 min, allowing time for plasma separation.

In a recent review, Deitrich (1976) has suggested that the production of acetaldehyde in the liver may be more rapid during the first few minutes than in the later, zero-order, phase of ethanol metabolism. Deitrich postulated that in the initial stages of ethanol oxidation, the amount of alcohol dehydrogenase, rather than NADH reoxidation, may be rate limiting for ethanol oxidation. An initial

'spike' of acetaldehyde in the blood was postulated to result from the initial more rapid ethanol oxidation. It was suggested that this has never been observed because all studies carried out so far have examined blood acetaldehyde concentrations no earlier than 30 min. after ethanol intake. In order to test this hypothesis, it was decided to measure acetaldehyde in a number of early blood samples taken within a few minutes from the beginning of ethanol ingestion.

Studies carried out on certain strains of rats and mice have indicated a possible sex difference with respect to levels of acetaldehyde which occur in the blood (Eriksson, 1975; Eriksson and Sippel, 1977) and breath (Redmond and Cohen, 1972). To determine whether such a difference occurs in humans, it was decided to employ similar numbers of both male and female volunteers for the studies outlined in this section. Blood levels of acetaldehyde found in human subjects metabolizing ethanol may be related to the rate of ethanol oxidation (Lester, 1962; Machata and Prokop, 1971) and it was of interest to determine ethanol oxidation rates in the subjects studied to detect possible correlations between these rates and the acetaldehyde levels found in both breath and blood samples.

The recent claim of Korsten et al (1975), that alcoholics have higher levels of circulating acetaldehyde than normal subjects when both groups have similar levels of blood ethanol, suggested that alcoholic subjects might also show higher levels of breath acetaldehyde, if peripheral blood acetaldehyde levels indeed reflect increased hepatic production of acetaldehyde. Since confirmation of the work of Korsten et al (1975) has not yet been reported in the literature it was decided to carry out a preliminary examination of acetaldehyde levels in the breath of alcoholic subjects to be compared with those found in normal volunteers.

## 6-2. METHODS.

### 6-2-1. Human subjects.

Apart from the alcoholic patients involved in this study, all subjects were healthy adult volunteers, working as students or staff at Massey University. The age of the volunteers ranged from 21 to 46 years.

The five alcoholics from whom breath acetaldehyde samples were taken, had been admitted to the Detoxication Unit of the Palmerston North Public Hospital as a result of ethanol intoxication. Breath samples were taken during the period when the patients were metabolizing the alcohol which they had ingested prior to hospital admission. No blood

samples were analyzed from these cases.

The dietary state of the healthy volunteers was known but not controlled; some having fasted for up to twelve hours and others having consumed a light lunch or breakfast before taking part in the experiments described here. The dietary state of the alcoholic subjects was unknown.

#### 6-2-2. Administration of ethanol to volunteers.

Ethanol was given to volunteers in the form of gin or vodka and the time taken to consume the full amount varied between 15 and 75 min. The gin or vodka was always diluted by approximately 50% before consumption, with either water or a carbonated beverage such as a lemonade.

#### 6-2-3. Blood samples.

Blood samples were taken under medical supervision by means of an indwelling cannula inserted in an arm vein and the cannula was kept patent between sampling using heparinized saline. For each blood sample, the first few ml of blood, containing heparin, were discarded and a clean syringe used to take a 10 ml blood sample for the analysis of whole blood and plasma acetaldehyde, and in most cases, whole blood ethanol as well. A blank blood sample was taken from all volunteer subjects before ingestion of ethanol, for the determination of endogenous ethanol and acetaldehyde.

#### 6-2-4. Whole blood and plasma assays.

Determination of whole blood and plasma levels of acetaldehyde was carried out using the fully-automated enzymic assay method described in Section 2-4-3, calibrated with aqueous acetaldehyde standards. Whole blood samples (0.5 ml) were diluted immediately after being drawn, with nine volumes of ice-cold 0.6 M PCA, prior to analysis of the acetaldehyde in the protein-free supernatants of these samples. The large dilution was used to minimize the level of acetaldehyde produced during the deproteinization process. In order to correct for the acetaldehyde which was produced in this way, correction curves of the type illustrated in Fig. 3-6 were constructed for each individual, using the methods described in Section 3. Duplicate determinations of the level of acetaldehyde produced during the deproteinization of blood samples containing five different concentrations of ethanol (0, 10, 20, 30 and 40 mM) were performed and the means of these duplicates were used to construct the correction curves. The blood samples used to produce the correction curves were obtained from each individual before ingestion of ethanol

took place. Correction of the acetaldehyde levels in whole blood samples was carried out after determining the level of ethanol in these samples, either by direct GC assay of ethanol as described by Couchman (1974) or by the method of breath ethanol analysis described in the following section. Once the blood ethanol levels were known, the corresponding levels of artefactually-produced acetaldehyde were read from the correction curves and subtracted from the 'apparent' levels of acetaldehyde measured by the enzymic assay.

Blood plasma samples (1.5 ml) were deproteinized immediately after separation from the cellular fraction was achieved and deproteinization was carried out with one volume of ice-cold 1 M PCA.

All whole blood and plasma protein-free supernatants were stored in sealed containers at 4°C prior to analysis and no samples were stored for longer than 24 h before analysis. No correction for the artefactual production of acetaldehyde in plasma samples was applied as this had previously been shown to be negligible (see Section 3-3-2).

#### 6-2-5. Measurement of acetaldehyde and ethanol in breath samples.

The concentrations of acetaldehyde in the breath samples obtained from healthy volunteers, including a blank sample taken before ethanol ingestion, were determined in the manner described in Section 5-2-10 with the exception that all breath samples (1 litre) were obtained after the expiry of at least 500 ml of air, in order to obtain alveolar air samples. The concentrations of acetaldehyde in the breath samples obtained from the alcoholic patients were determined after collecting the acetaldehyde present in 1 litre of mainly tidal air in a single trap of the type illustrated in Fig. 5-2. A calibrated plastic bag connected to the gas outlet of the bubbler tube containing the acetaldehyde trapping solution was used to determine the volume of breath sampled. The patients expired directly into the inlet tube of the gas bubbler tube and alveolar air was not sampled because some of the patients had difficulty in producing a large volume of air in one expiration. Most of the samples were the sum of 3 - 4 short expirations.

The measurement of ethanol present in breath samples as described in Section 5-2-10 was used to determine blood ethanol levels. Calibration of the gas chromatograph with simulated breath samples produced using the MK IIA breath alcohol simulator facilitated the conversion of breath ethanol levels to blood levels. The blood:air partition ratio which was used for this conversion was that determined by Harger et al (1950b) i.e. 2,100.

Breath samples taken for the estimation of blood alcohol levels were always alveolar and usually at  $34^{\circ}\text{C}$ . If samples were not at this temperature, a correction was made for the temperature difference as described in Section 5-2-10. The blood ethanol concentrations plotted in Figs. 6-1, 6-2 and 6-3 were determined by analysis of breath alcohol.

No breath samples were taken from any subject until at least 10 min after ceasing drinking, in order to avoid falsely high levels of breath alcohol or acetaldehyde which could have resulted from the presence of these compounds in residual vodka or gin remaining in the mouth.

### 6-3. RESULTS.

#### 6-3-1. Breath acetaldehyde concentrations after the ingestion of ethanol in doses of 0.5 and 1.0 g/kg body weight.

Because most of the volunteers involved in this study were not heavy drinkers, it was originally decided to use a standard ethanol dose of 0.5 g/kg for all experiments. This dosage has previously been shown to produce maximum blood ethanol levels between 7.2 and 21 mM and does not result in severe intoxication (Couchman, 1974). In two experiments using the above dose of ethanol with two male volunteers, it was found that breath acetaldehyde concentrations produced during the metabolism of this ethanol load were very low and many approached the limit of detection for the assay method employed. Since Freund and O'Hollaren (1965) found that the level of acetaldehyde in the breath of humans metabolizing ethanol is at least partly dependent on the amount of ethanol ingested, it was decided to double the ethanol load to 1.0 g/kg in an attempt to produce larger amounts of acetaldehyde in the breath samples. The results shown in Fig. 6-1 indicate that breath acetaldehyde concentrations are dependent on blood ethanol concentrations; a doubling of the ethanol load administered to the subjects resulted in a 4 - 5 fold increase in breath acetaldehyde concentrations. The two subjects who took part in these experiments drank vodka and had fasted for 12 h prior to the experiments.

Since the breath acetaldehyde concentrations determined after the ingestion of the higher ethanol dose were readily detectable, it was decided to use this dose of ethanol for all other experiments. Although ingestion of the 1.0 g/kg dose of ethanol resulted in nausea and vomiting in two of the subjects employed in these studies, the other nineteen subjects exhibited no obvious ill effects apart from mild intoxication.

FIGURE 6-1. BLOOD ETHANOL AND BREATH ACETALDEHYDE LEVELS OF TWO MALE SUBJECTS AFTER THE CONSUMPTION OF ETHANOL LOADS OF 0.5 AND 1.0g/kg.

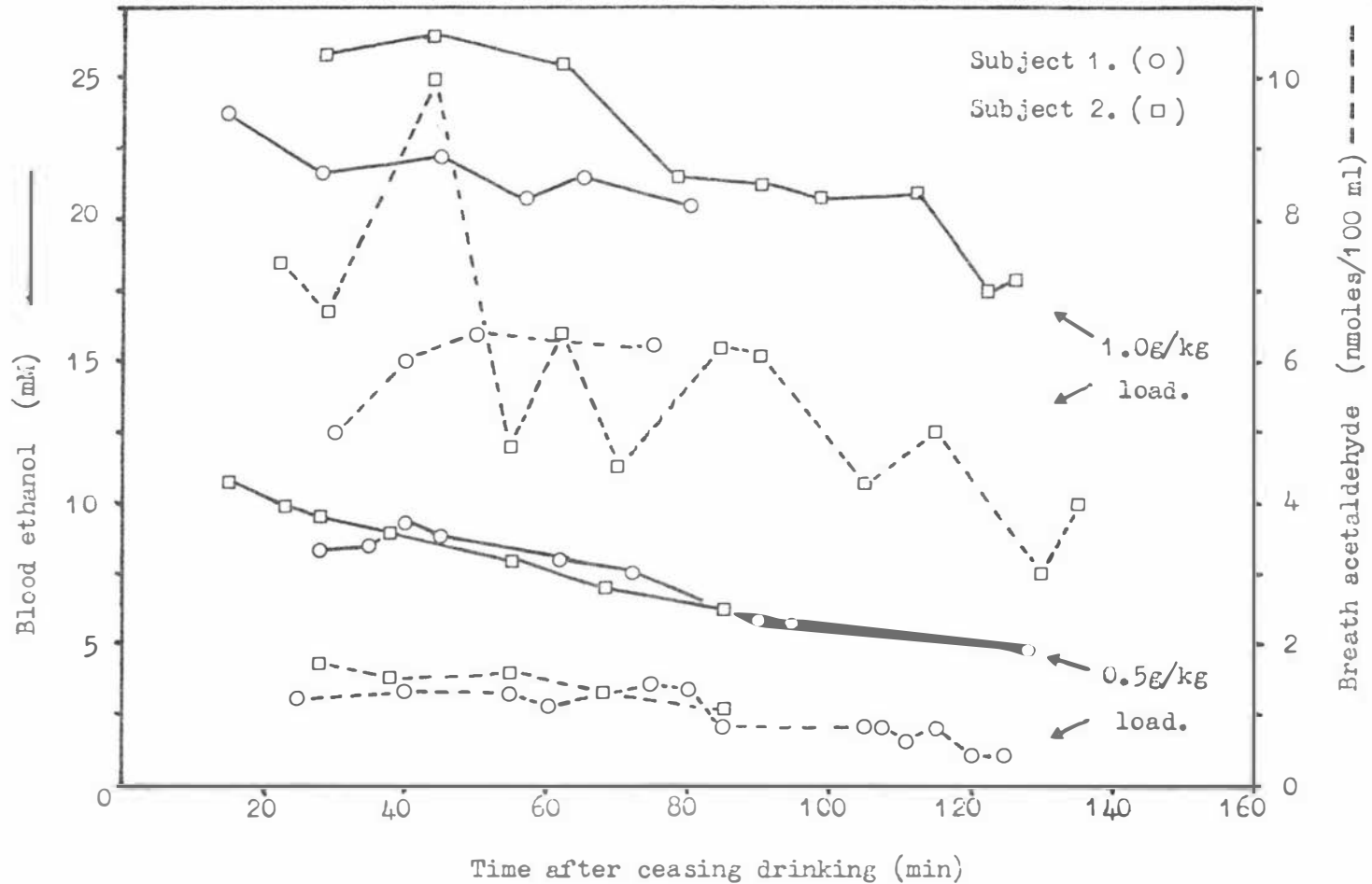

6-3-2. Intra-individual variation in the levels of breath acetaldehyde determined after a standard dose of ethanol.

In order to determine whether variations in breath concentrations of acetaldehyde between different subjects were due to actual individual differences or a normal variation common to all individuals, the levels of acetaldehyde produced in the breath of a single male subject were studied in three separate experiments after the consumption of a standard 1.0 g/kg dose of ethanol, as vodka. The time elapsed between the first and second, and the second and third experiments, was three and four months respectively.

The results of the three experiments are illustrated in Fig. 6-2 and the means of the recorded breath acetaldehyde concentrations for each separate experiment were calculated to be (in chronological order):- 4.7, 4.3 and 4.3; the ranges being 3.1 - 6.0, 2.6 - 5.9, and 3.2 - 6.5 respectively. Interpretation of these results is difficult because of the large fluctuations in the level of breath acetaldehyde determined during the time course of each separate experiment. However, the close similarity of the means and ranges of the acetaldehyde concentrations measured in all three experiments suggested that the level of acetaldehyde produced in the breath during the metabolism of a standard dose of ethanol may be constant within limits for an individual. This conclusion is supported by the work of Freund and O'Hollaren (1965) who found that the levels of acetaldehyde produced in the breath of an individual after standard doses of ethanol given at different times, did not vary significantly.

The dietary state of the subject involved in the above experiments was not controlled. For the first experiment, the subject had fasted for 8 h prior to drinking and for the second two experiments, the subject had eaten a light lunch immediately prior to drinking. The difference in dietary state had no obvious effect on the levels of acetaldehyde produced in the breath in the three separate experiments and therefore the observed differences in breath acetaldehyde concentrations between individuals are probably due to some factor other than food intake.

6-3-3. Inter-individual variation in the levels of breath acetaldehyde determined after a standard dose of ethanol.

Six male and three female volunteers consumed an ethanol dose of 1.0 g/kg after which both breath ethanol and acetaldehyde levels were monitored until a linear rate of ethanol clearance was evident. This was done so that rates of ethanol metabolism could be compared with breath acetaldehyde levels. No comparison of blood and breath acetaldehyde levels could be made because this series of experiments was carried out before the development of a reliable method for the determination of blood

FIGURE 6-2. VARIATION IN THE BREATH ACETALDEHYDE CONCENTRATIONS OF ONE INDIVIDUAL, AFTER THREE STANDARD 1.0g/kg ETHANOL LOADS.

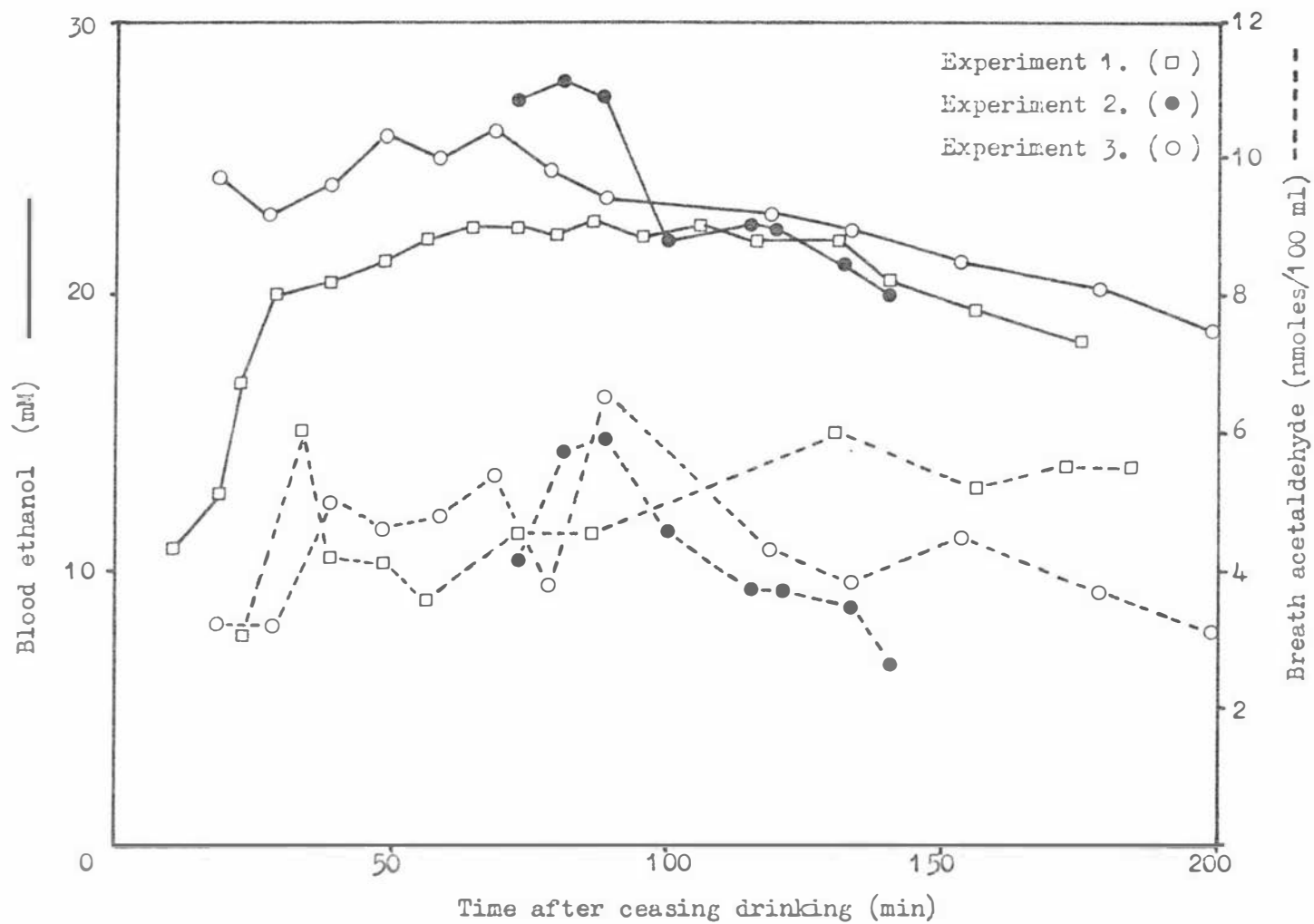

acetaldehyde.

The results obtained are illustrated in Figs. 6-3a to 6-3e and indicate that the inter-individual variation in breath acetaldehyde levels is larger than the intra-individual variation, after a standard dose of ethanol. Although the changes in the concentration of acetaldehyde in the breath with time during ethanol metabolism do not appear to be completely random, they do not conform to any set pattern, and as a result, quantitative evaluation of the apparent inter-individual differences is difficult.

Because the concentrations of acetaldehyde produced in the breath of human subjects were not constant during the linear phase of ethanol decay and because there was no obvious relationship between the rate of ethanol clearance and breath acetaldehyde levels, no attempt was made to correlate these two variables. The only indication that the rate of ethanol metabolism may be related to the level of acetaldehyde in the breath was the observation that the two subjects having the slowest rates of ethanol clearance both showed the lowest levels of breath acetaldehyde (subjects 4 and 8). However, the ethanol clearance rate in one of the alcoholic subjects studied was 8.7 ml/h i.e. approximately twice the rate normally measured in the healthy volunteers. This subject exhibited breath acetaldehyde levels well within the range found in the normal volunteers and is further evidence for the lack of a direct relationship between the rate of ethanol metabolism and the level of acetaldehyde in the breath. The rates of ethanol clearance for each individual were calculated by least-squares analysis of the points on the linear portions of the ethanol clearance curves having negative slopes.

#### 6-3-4. Breath acetaldehyde levels in alcoholics.

Fig. 6-4 illustrates the breath acetaldehyde levels determined in samples of breath taken from alcoholics during the metabolism of varying self-inflicted doses of ethanol.

An ethanol clearance rate was measured for patient 3 only, using breath ethanol analysis, and was found to be 8.7 ml/h.

The breath acetaldehyde levels measured in the alcoholic patients were within the range measured in the normal volunteers (0.5 - 10 nmoles/100 ml) except for patient 1 who was known to be suffering from liver disease.

#### 6-3-5. Acetaldehyde in plasma, whole venous blood and breath of human subjects metabolizing a standard dose of ethanol.

A series of experiments was carried out in which five male and four female volunteers consumed a standard dose of ethanol (1.0 g/kg) after

FIGURES 6-3a to 6-3e. INTER-INDIVIDUAL VARIATION IN THE LEVELS OF BREATH ACETALDEHYDE DETERMINED AFTER A STANDARD DOSE OF ETHANOL.

FIGURE 6-3a.

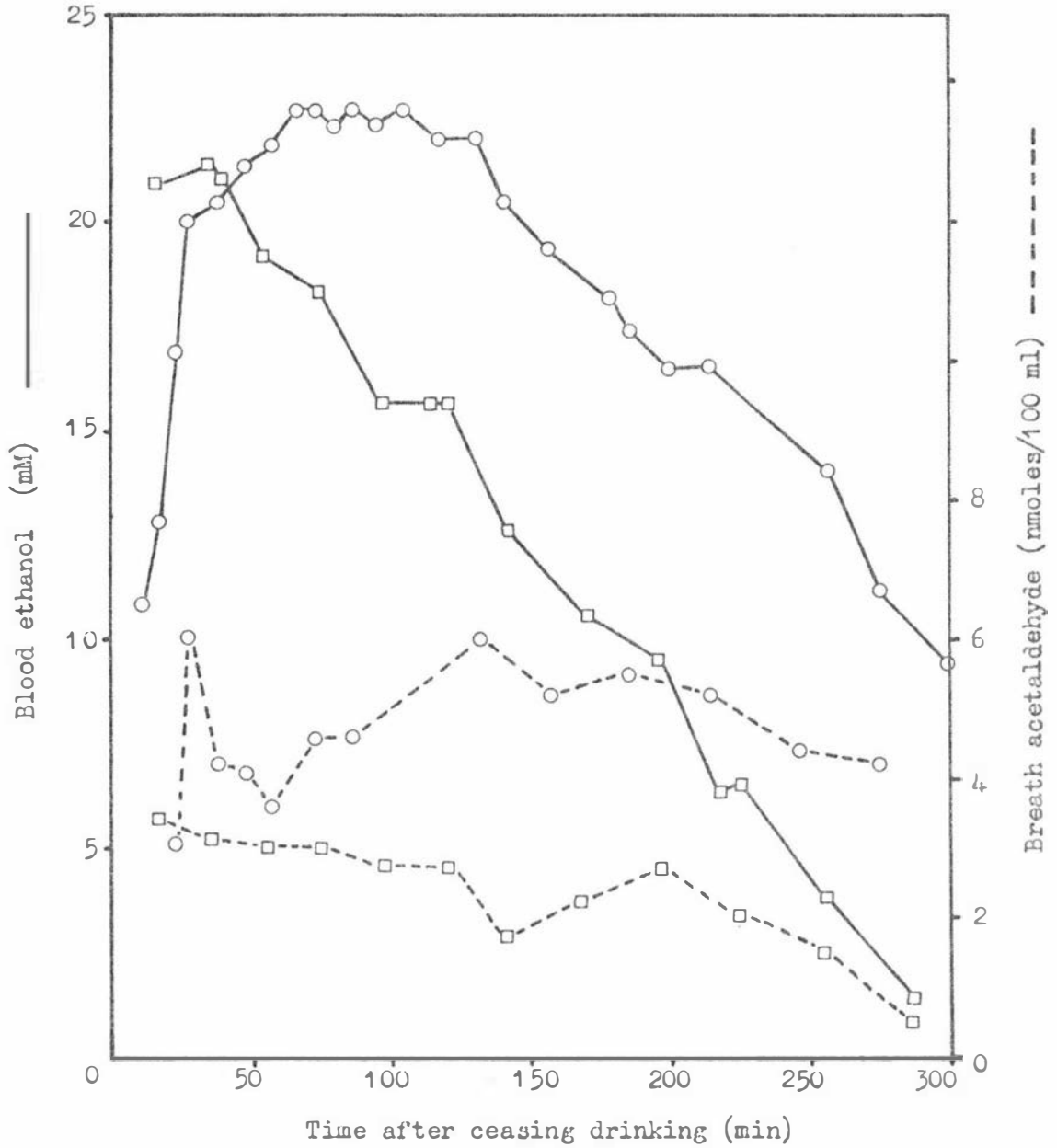

Subject.	Ethanol clearance rate (mM/h)
1 (○) ♂	4.38
2 (□) ♀	4.68

FIGURE 6-3b.

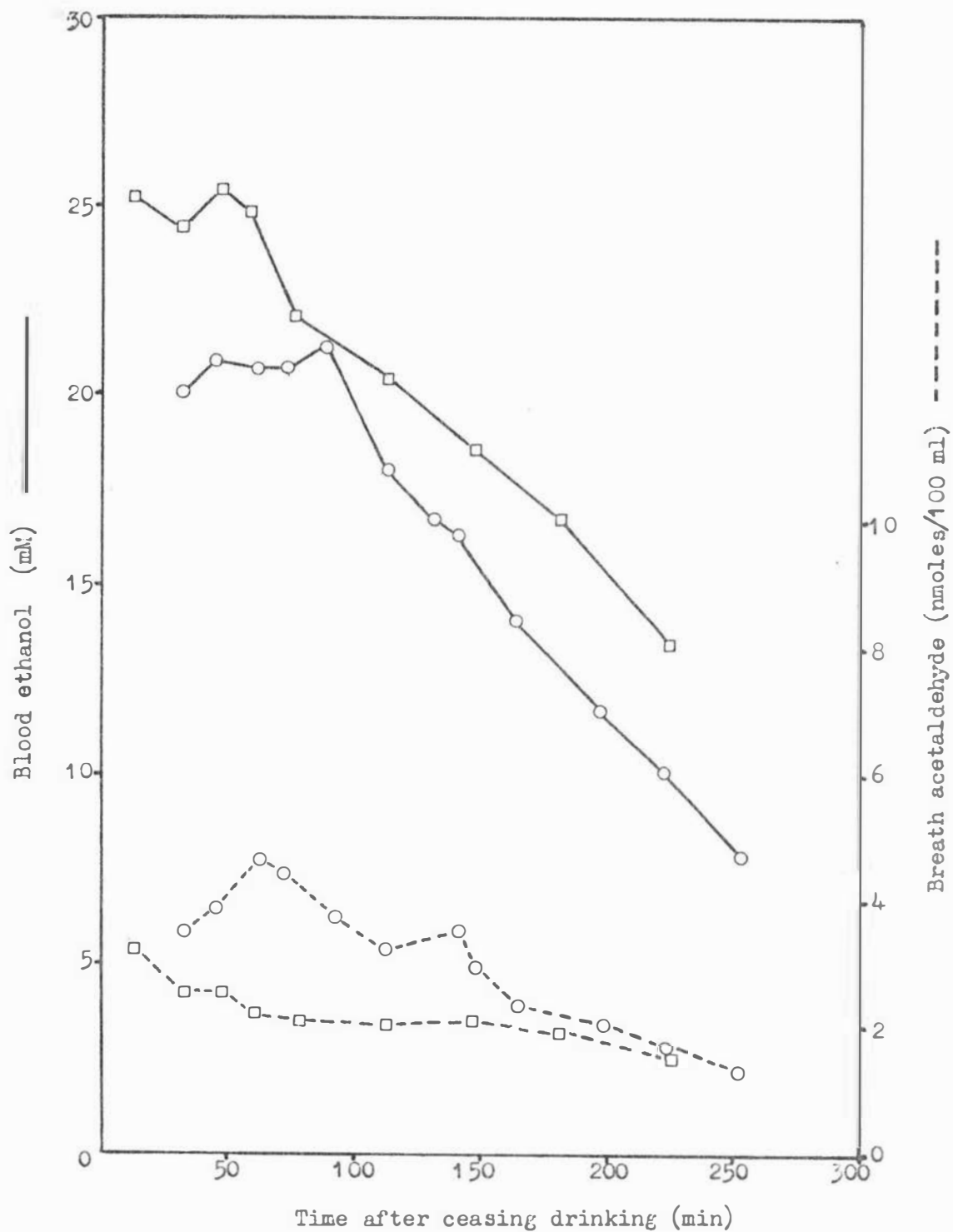

Subject.

Ethanol clearance rate (mM/h)

3 (○) ♂

4.38

4 (□) ♀

3.50

FIGURE 6-3c.

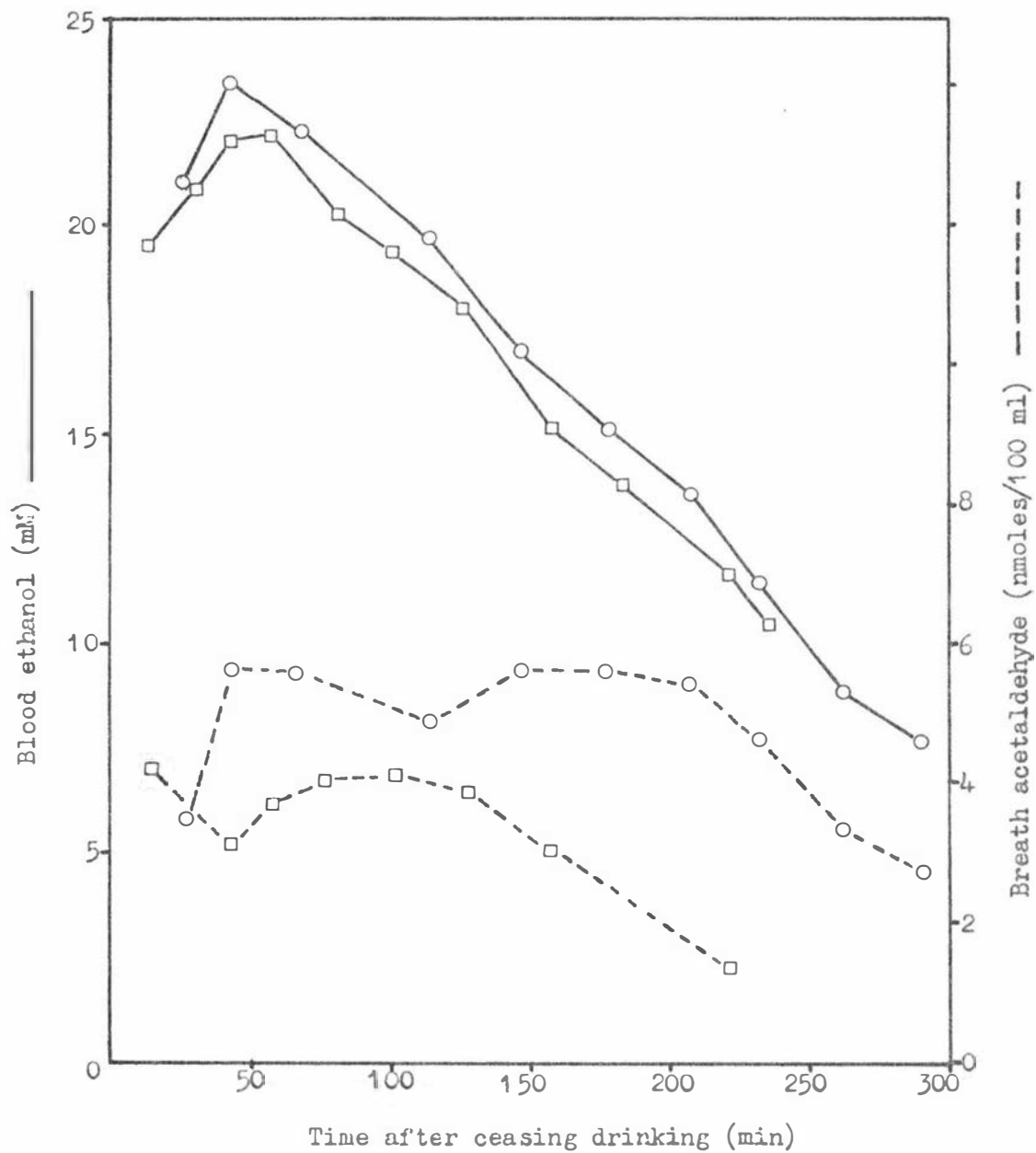

Subject. Ethanol clearance rate (mM/h)

5 (○) ♂ 3.86

6 (□) ♂ 3.92

FIGURE 6-3a.

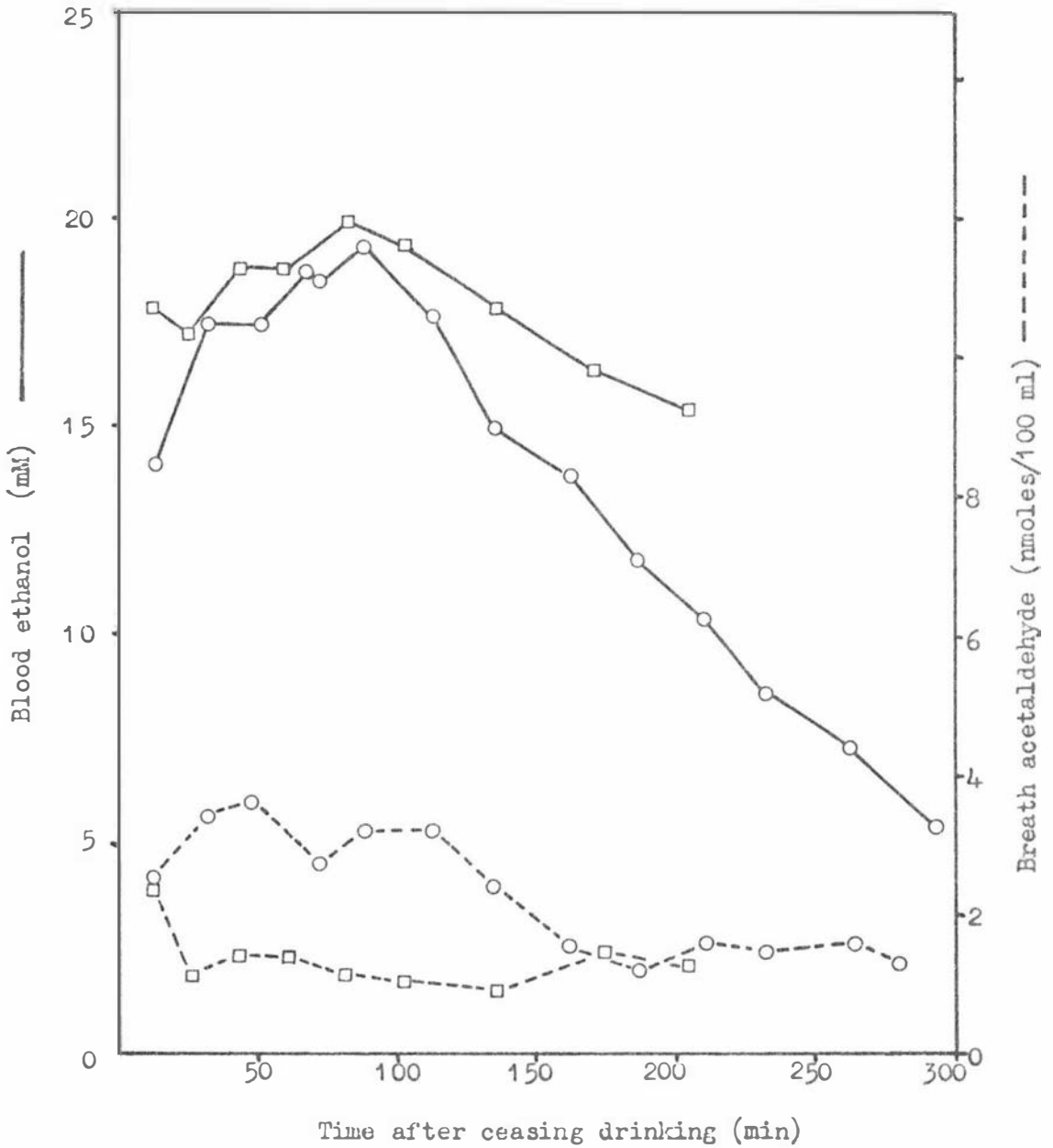

Subject.	Ethanol clearance rate (mL/h)
7 (○) ♂	3.67
8 (□) ♀	2.33

FIGURE 6-3e.

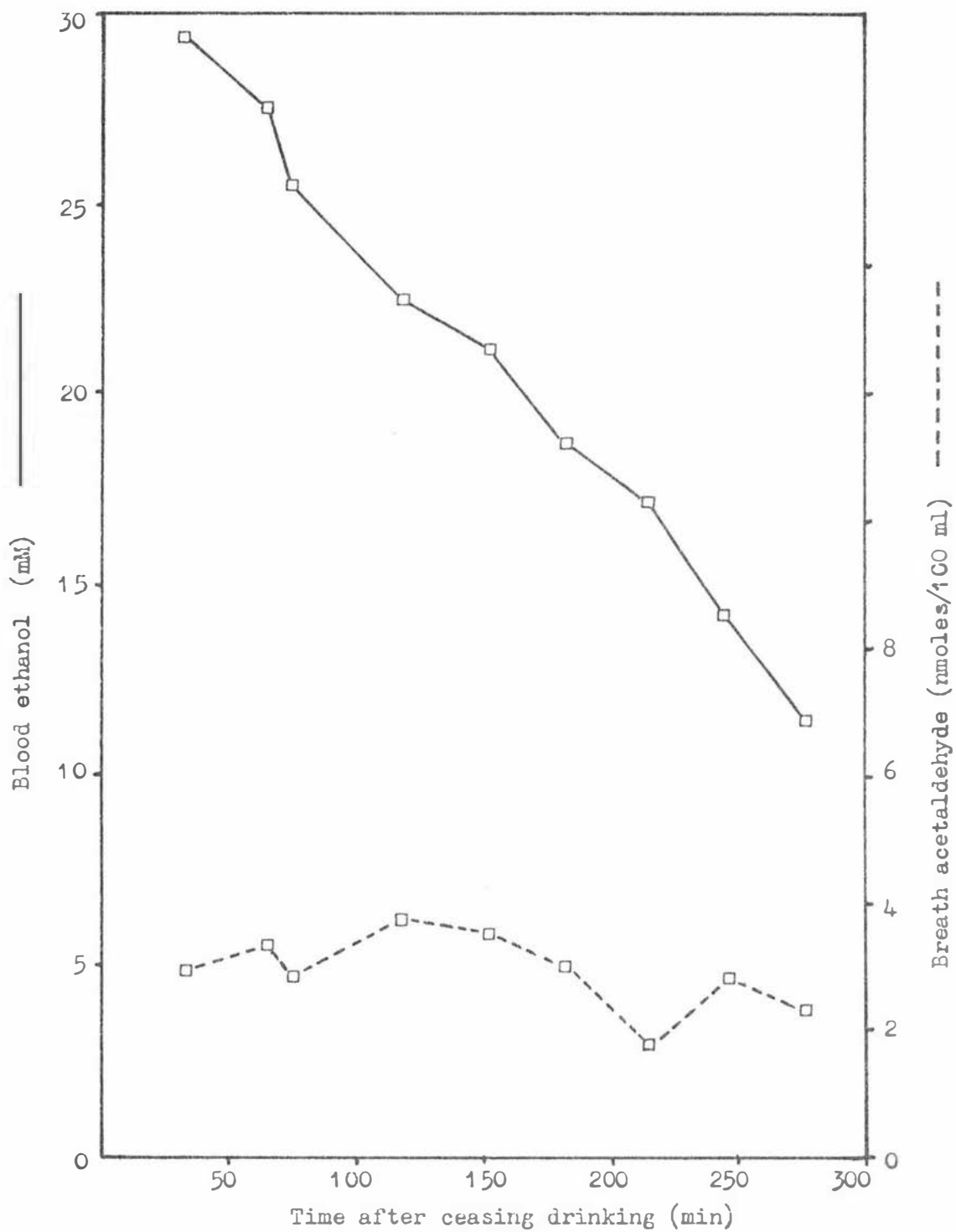

Subject. Ethanol clearance rate (mM/h)

9 (□) ♂

4.38

FIGURE 6-4. BREATH ACETALDEHYDE LEVELS VERSUS BLOOD ETHANOL CONCENTRATIONS IN ALCOHOLIC PATIENTS.

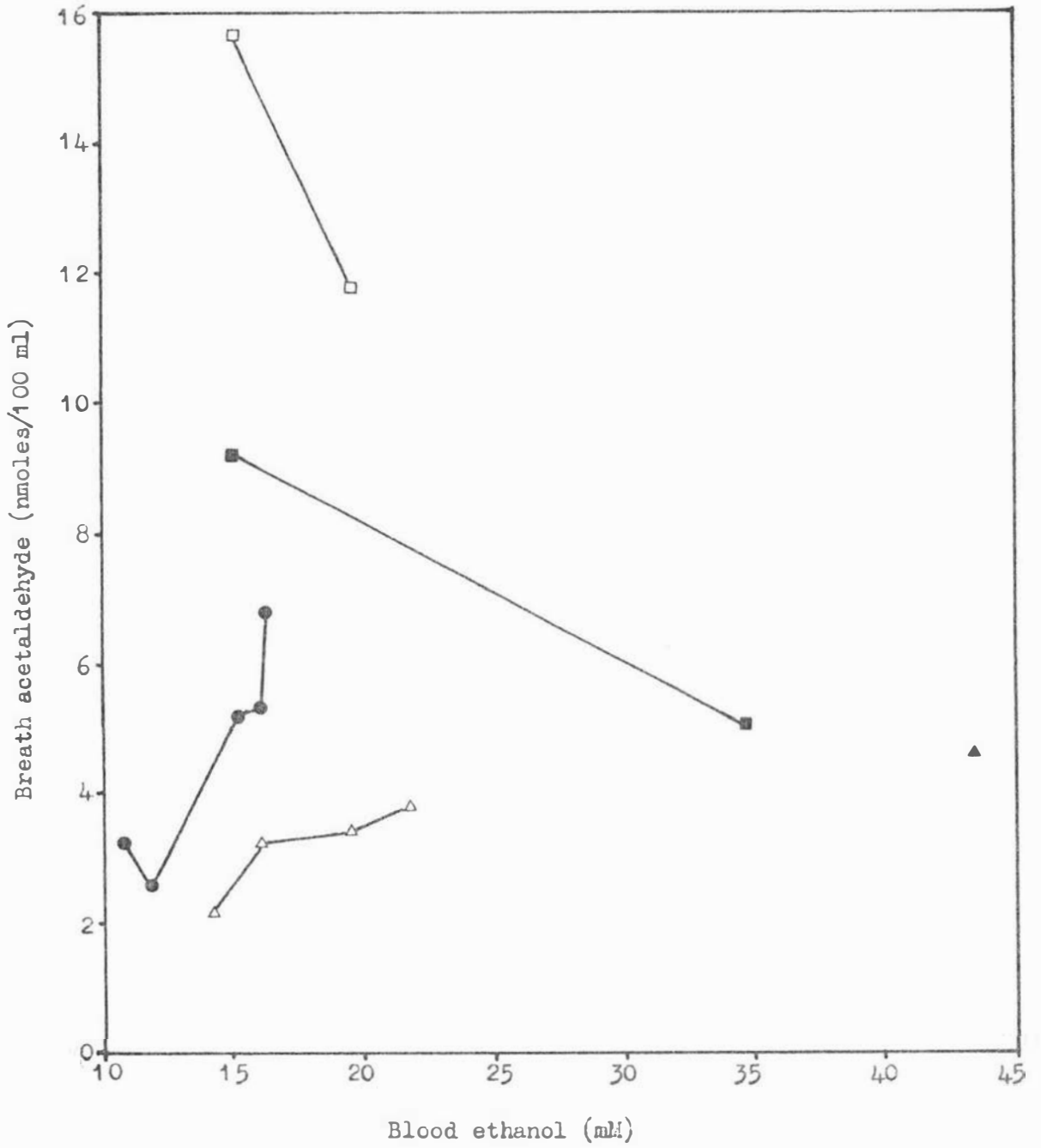

Patient 1 (●)  
Patient 2 (□)  
Patient 3 (△)  
Patient 4 (▲)  
Patient 5 (■)

which breath alcohol and acetaldehyde levels were measured at regular intervals for up to three hours after ceasing drinking. Parallel determinations of plasma and whole blood acetaldehyde, as well as blood ethanol levels were performed so that blood and breath acetaldehyde levels determined at the same time could be compared.

It was intended to take the same number of blood samples from each subject. However, difficulties were encountered in taking blood samples from some individuals and as a result, not all breath acetaldehyde levels could be compared with corresponding blood levels.

The blood ethanol levels used in conjunction with the acetaldehyde corrections curves to correct for the acetaldehyde produced during the deproteinization of whole blood samples, were determined by breath ethanol analysis. The corrected acetaldehyde concentrations were found to be the same (within the limits of experimental error) whether actual peripheral blood ethanol concentrations or pulmonary blood ethanol levels as determined by breath analysis were used.

The results of this series of experiments are presented in Figs. 6-5a to 6-5i. The first point on the abscissa of all graphs represents the time at which all blank samples were taken, i.e. immediately before ethanol was consumed. The breath acetaldehyde and blood ethanol levels measured in this series of experiments have not been presented, however, they were all found to lie within the ranges previously measured. The measured breath acetaldehyde levels have been converted to pulmonary blood acetaldehyde levels using the average blood:air partition ratio for acetaldehyde of 189, determined as described in Section 5-2-8. No statistical comparison was made of the breath acetaldehyde concentrations of male and female volunteers. With the exception of subject 1, who produced the highest levels of breath acetaldehyde of the nine subjects studied, the levels of acetaldehyde produced by males and females lay within similar ranges.

#### 6-3-6. Levels of acetaldehyde in peripheral blood immediately after drinking.

In order to determine whether blood acetaldehyde levels are higher during the early phase of ethanol oxidation and to test the hypothesis of Deitrich (see Introduction), serial blood samples were taken at short intervals (1 - 2 min) from two female subjects immediately after the subjects began to consume an ethanol load. The blood samples were analyzed for both ethanol and acetaldehyde and the results are illustrated in Fig. 6-6.

FIGURES 6-5a to 6-5i. ACETALDEHYDE IN PLASMA, WHOLE VENOUS BLOOD AND PULMONARY BLOOD OF HUMAN SUBJECTS METABOLIZING A STANDARD DOSE OF ETHANOL.

FIGURE 6-5a.

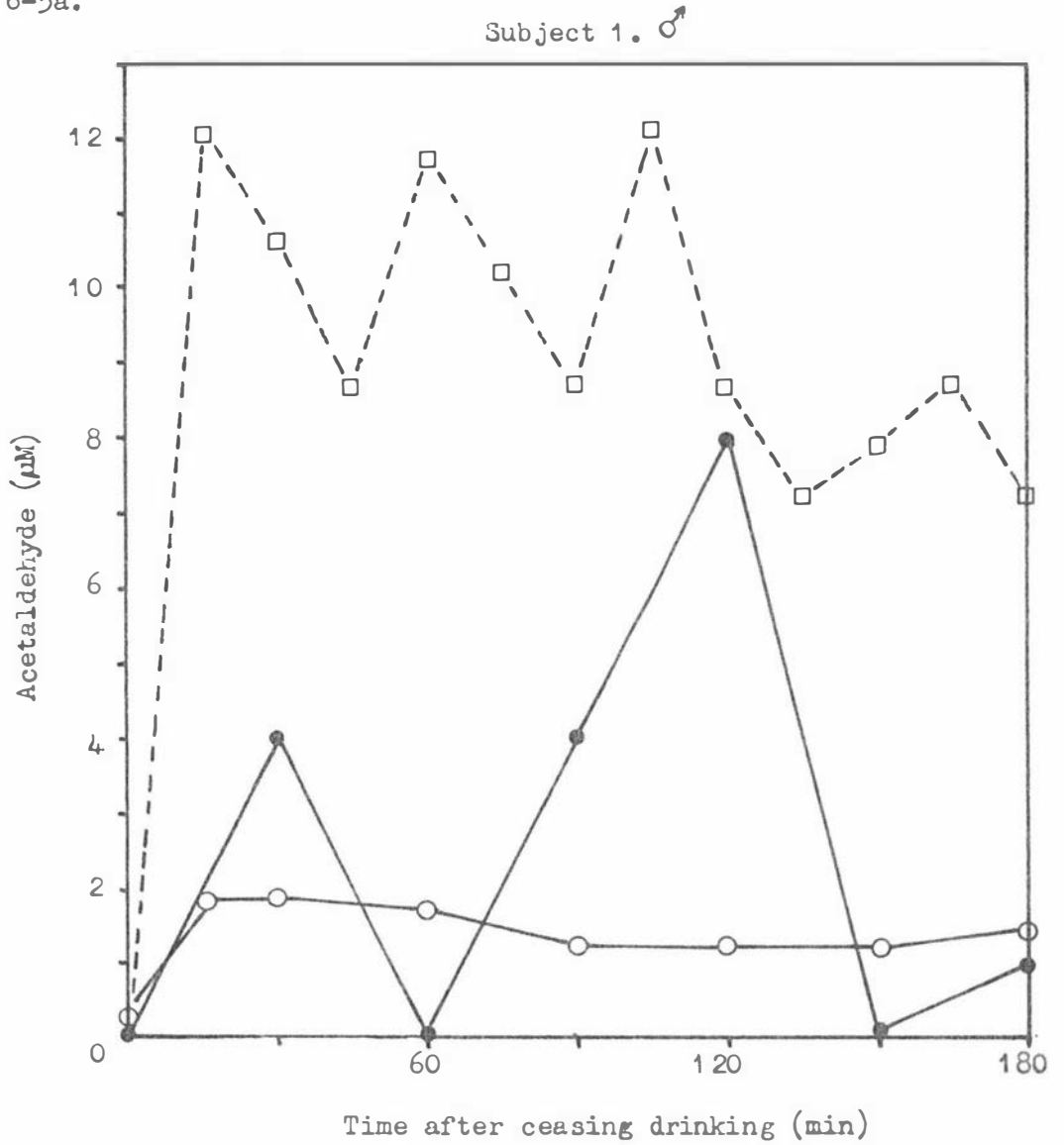

KEY

Plasma	( ○ ——— ○ )
Pulmonary blood	( □ - - - - □ )
Venous blood	( ● ——— ● )

FIGURE 6-5b.

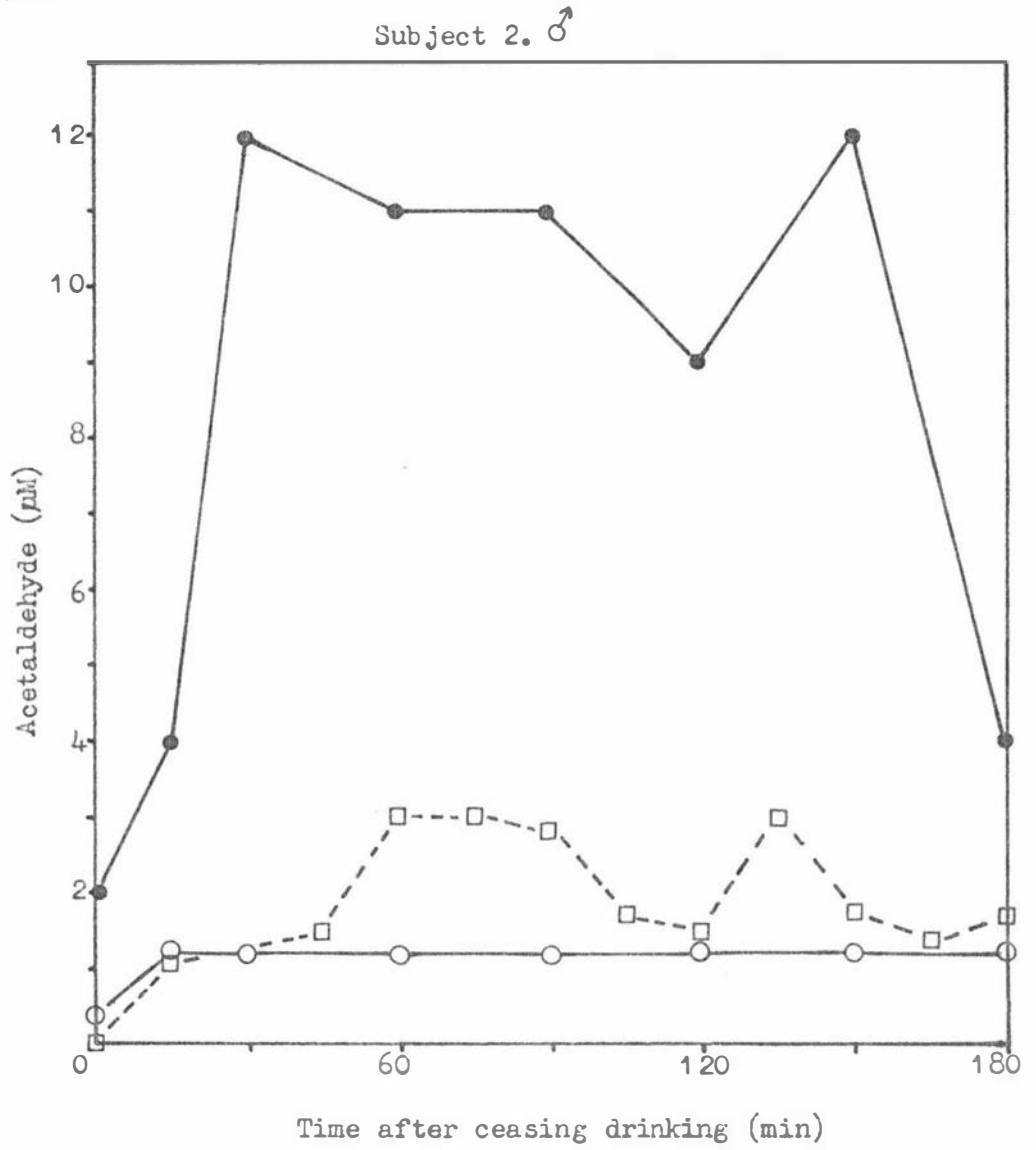

FIGURE 6-5c.

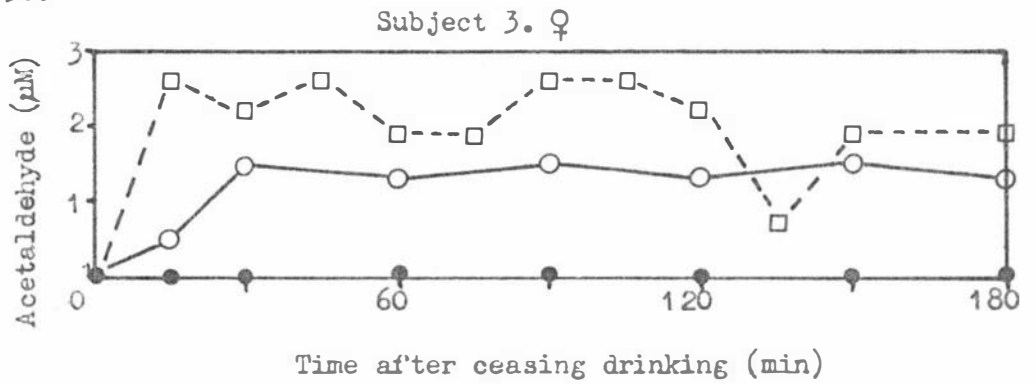

FIGURE 6-5d.

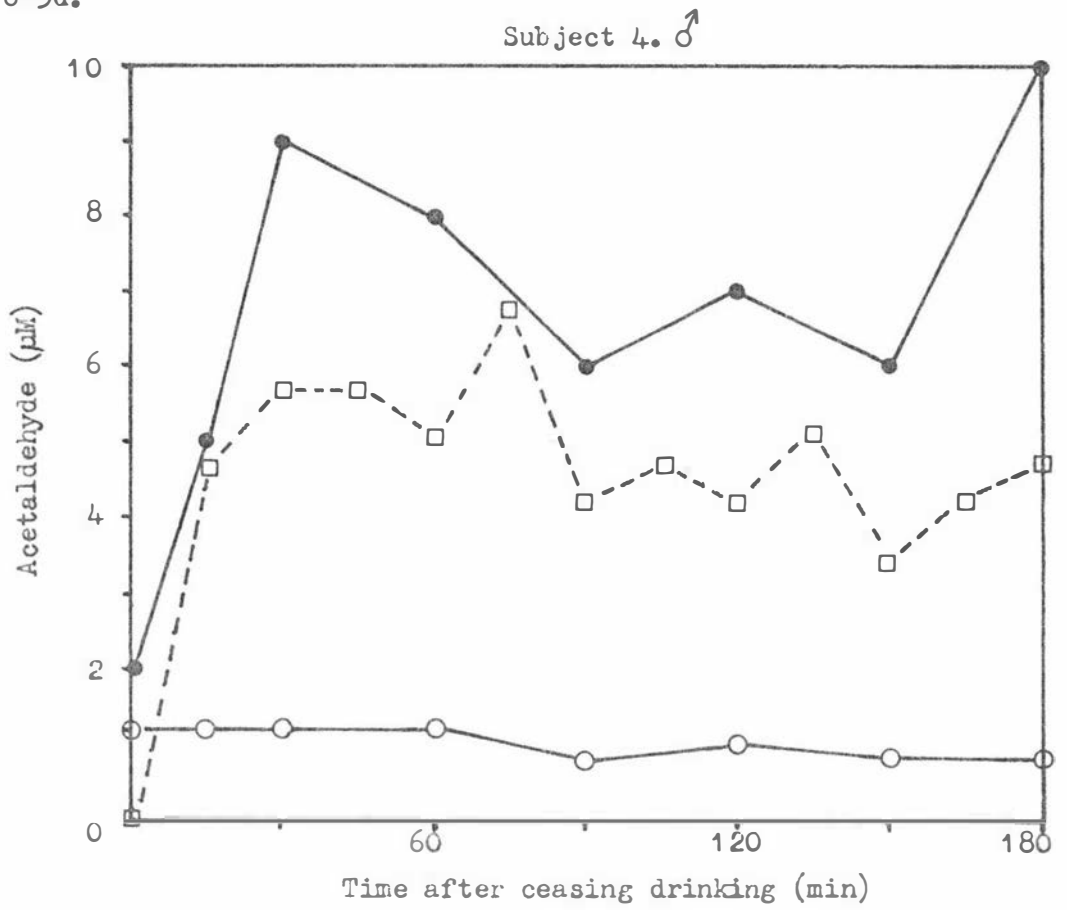

FIGURE 6-5e.

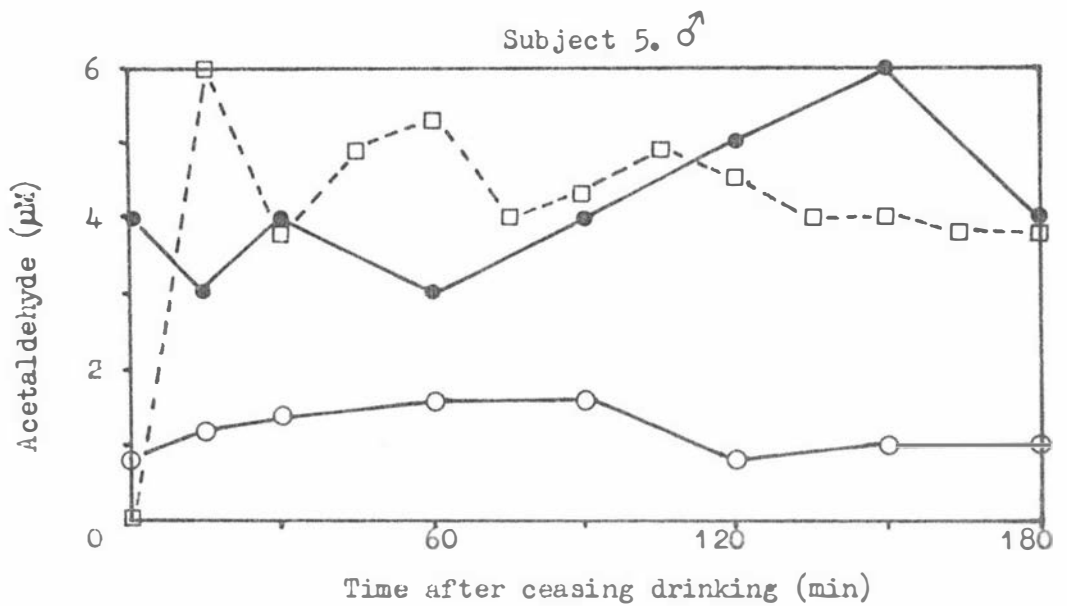

FIGURE 6-5f.

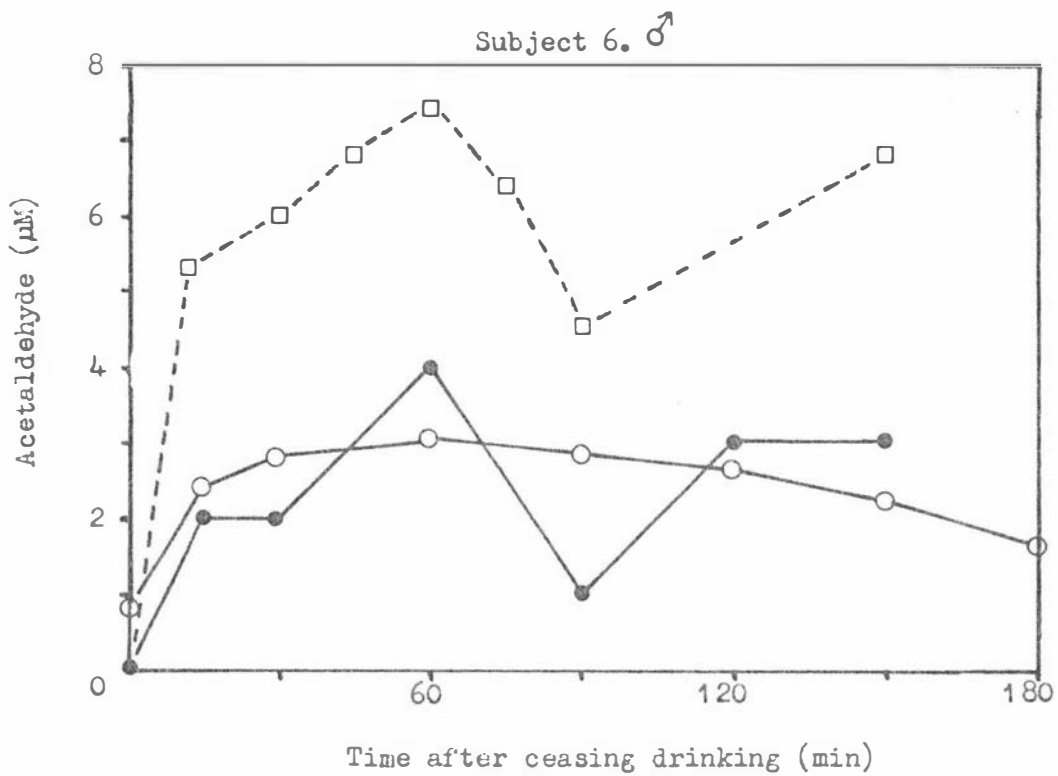

FIGURE 6-5g.

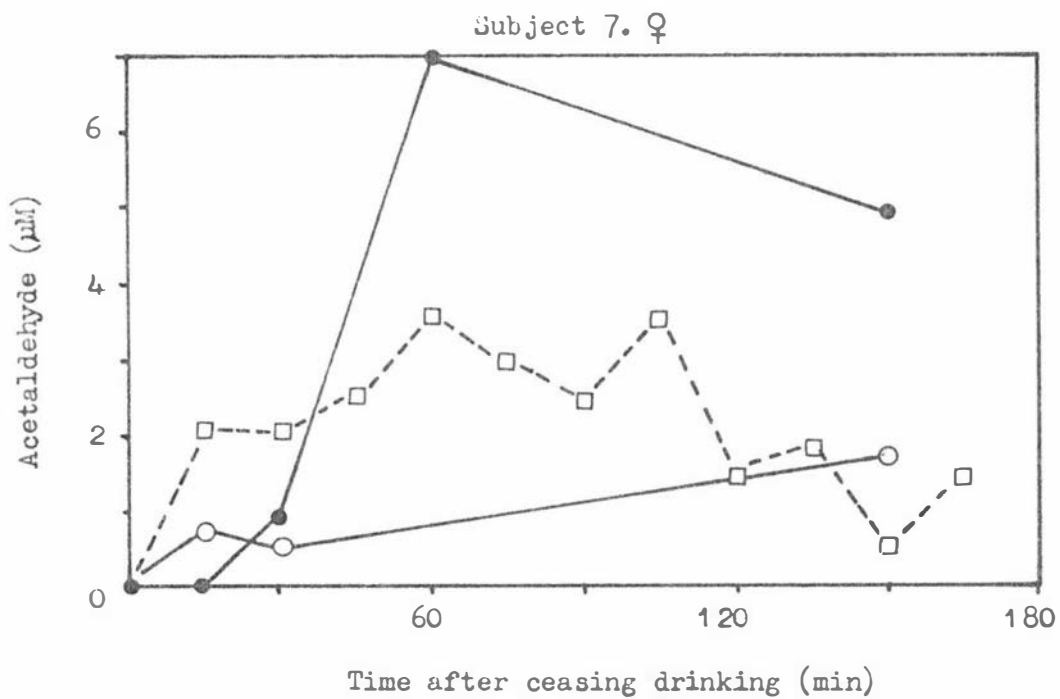

FIGURE 6-5h.

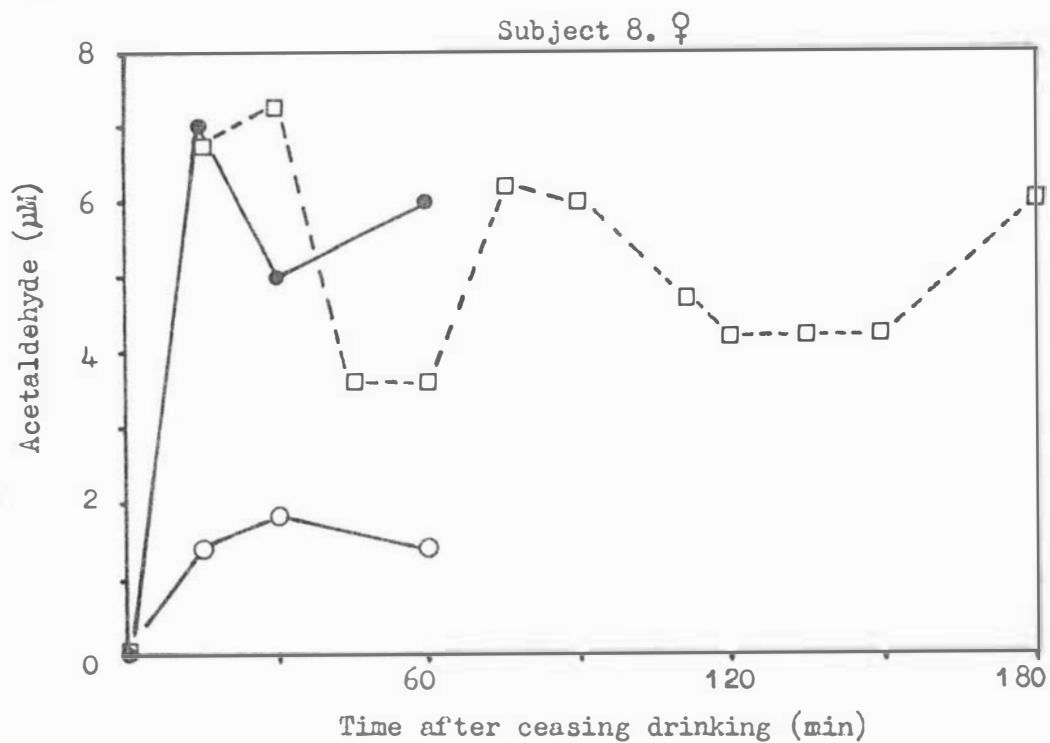

FIGURE 6-5i.

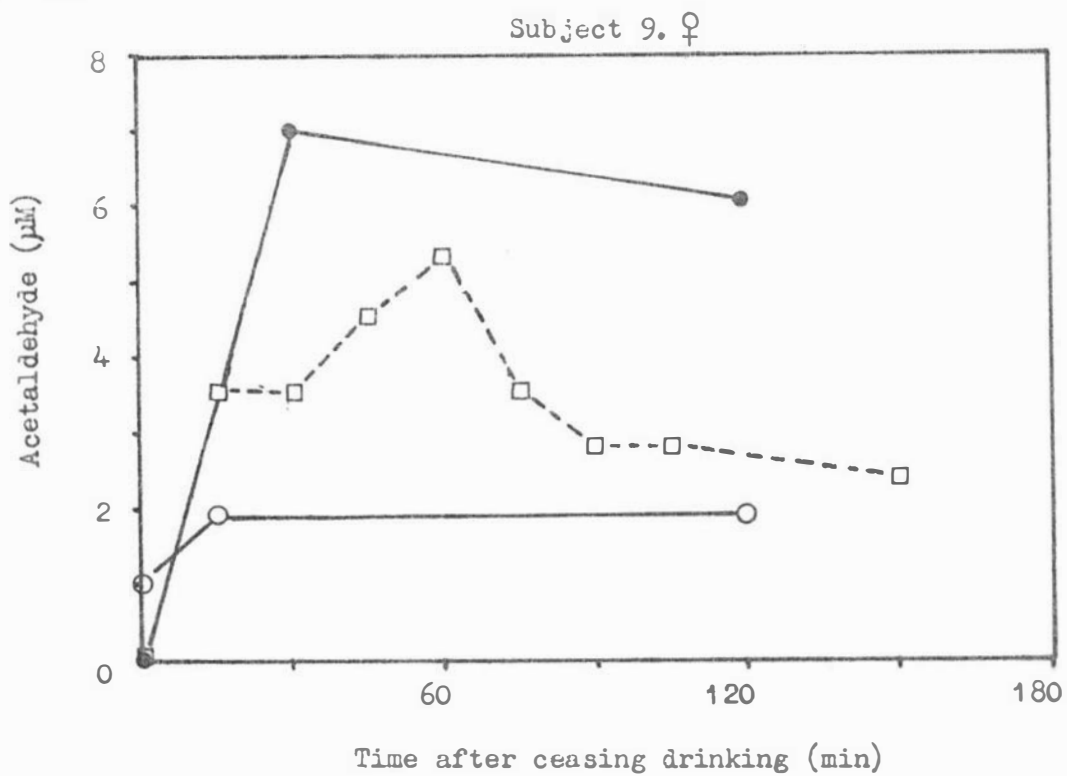
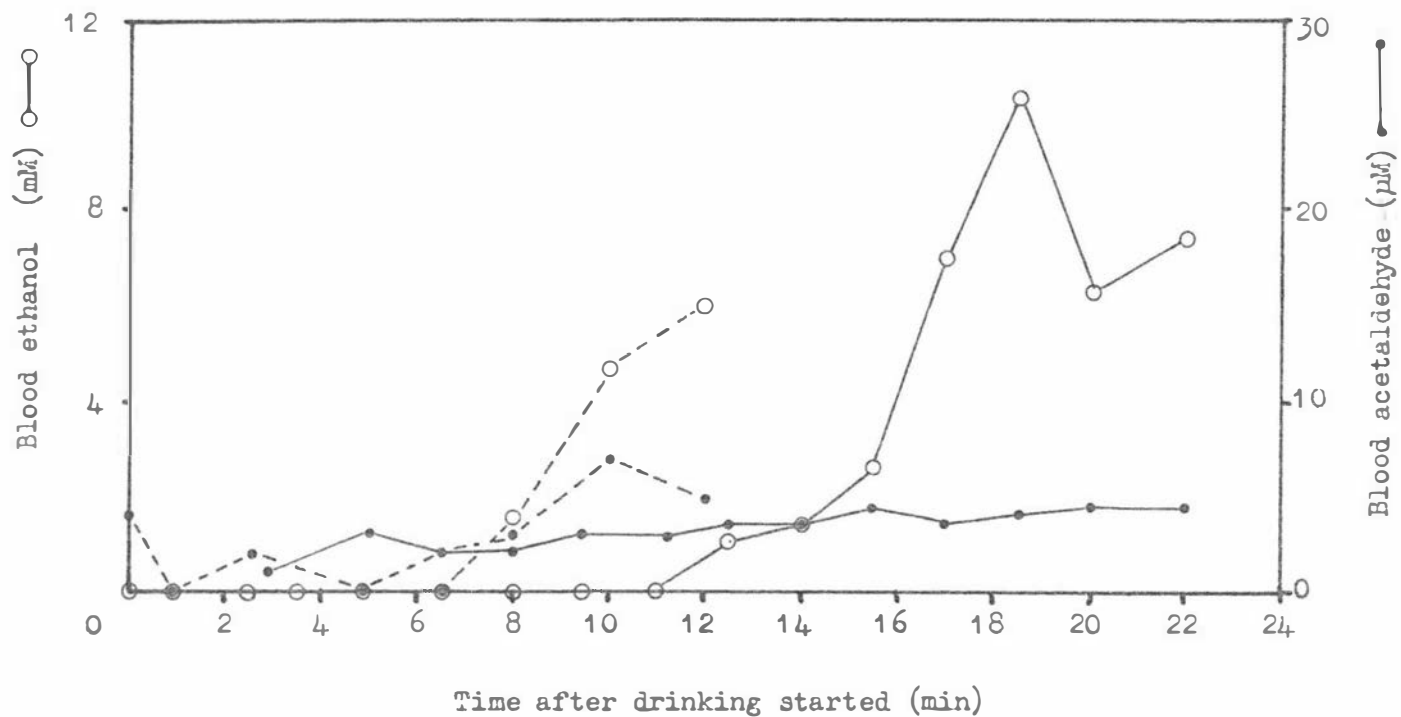

FIGURE 6-6. LEVELS OF ETHANOL AND ACETALDEHYDE IN PERIPHERAL VENOUS BLOOD IMMEDIATELY AFTER INITIATION OF ETHANOL CONSUMPTION.



Subject 1 (-----)

Subject 2 (—————)

Although it can be seen from Fig. 6-6 that the sampling method employed for this experiment enabled the initial rapid rise in blood ethanol levels to be detected, no large change in acetaldehyde concentration was observed in either subject. It may be assumed therefore, that either there is no initial 'spike' of acetaldehyde from the liver during the first few minutes of ethanol oxidation or, if it is produced, it is not observed in peripheral blood.

It might be expected that unless the hypothetical 'spike' of acetaldehyde production was very large, and lasted for several minutes, it would not be observed in peripheral blood due to dilution and the metabolism of acetaldehyde before reaching the venous system. It could possibly be observed in the breath because of the very short time interval required for blood to pass from the liver to the lungs. In order to test this, however, an infusion of ethanol would be necessary so that breath samples could be taken during ethanol administration.

#### 6-4. DISCUSSION.

The simultaneous measurement of acetaldehyde concentrations in plasma and whole blood has shown that, in general, plasma levels of acetaldehyde do not reflect the levels of acetaldehyde measured in whole blood. With few exceptions, whole blood acetaldehyde levels were found to be higher than plasma levels, which were consistently lower than  $3 \mu\text{M}$ . These findings confirm the results of Crow (1975) but are contrary to those obtained by Eriksson et al (1977) who found a significant difference between the concentrations of acetaldehyde in whole blood and plasma fractions of rat blood but not in human blood. The reason for this discrepancy is unknown but is possibly related to differences in the assay methods used.

The uneven distribution of acetaldehyde throughout the two main fractions of human blood found in this study, provides further evidence for the binding of acetaldehyde to erythrocytes and since ethanol-derived acetaldehyde present in peripheral blood does not decay significantly under conditions in which free acetaldehyde added to such blood is removed rapidly (see Section 4-3-6), it appears that the acetaldehyde measured in both the plasma and erythrocytes of peripheral blood may be bound in some way. If this is correct, and free acetaldehyde does not exist in human peripheral blood, then acetaldehyde may not be available to exert toxic effects in peripheral tissues. Acetaldehyde may have some toxic effects on blood cells if binding to this fraction of blood does occur, as suggested by Gaines et al (1977), but its importance in the effects of alcohol on peripheral tissues may be negligible.

The levels of acetaldehyde in whole blood determined in this study are similar to those measured by Korsten et al (1975) at similar blood ethanol concentrations. Comparison with other studies was not considered worthwhile because no corrections for the formation of acetaldehyde during the deproteinization of blood samples have been applied by other workers. As a result, blood acetaldehyde levels much higher than those determined in this study have been measured (see Crow, 1975). Korsten et al (1975) found peripheral blood levels of acetaldehyde to be significantly higher in alcoholic subjects than in non-alcoholic subjects, suggesting that the higher levels were due to decreased catabolism of acetaldehyde, possibly a result of ethanol-induced liver damage. The possibility that the acetaldehyde measured by Korsten et al (1975) was bound to blood components, was not considered by these workers and makes the interpretation of their findings difficult. The results illustrated in Figs. 6-5a to 6-5i suggest that there is no relationship between the estimated pulmonary blood acetaldehyde levels and the levels of acetaldehyde in either plasma or whole blood therefore it must be concluded that peripheral blood acetaldehyde levels do not reflect hepatic output of acetaldehyde.

The breath acetaldehyde levels measured in the five alcoholic patients in this study do not indicate an obvious difference between alcoholic and normal subjects with respect to hepatic acetaldehyde production. To determine whether a significant difference does exist, many more subjects would have to be tested, under controlled experimental conditions.

On the basis of a study of human breath acetaldehyde levels, Freund and O'Hollaren (1965) suggested that alcoholic subjects may have higher blood acetaldehyde levels than normal subjects when both groups are metabolizing the same dose of ethanol. However, these workers studied only five normal and three alcoholic subjects, with only one of the alcoholics showing breath acetaldehyde levels which were significantly higher than those measured in the normal subjects.

Because of the possibility that peripheral blood acetaldehyde levels may have limited relevance to hepatic acetaldehyde output, and the lack of data relating to acetaldehyde levels in the breath of alcoholic, and non-alcoholic subjects, the existence of a difference in hepatic acetaldehyde output between these two groups is questionable. Even if such a difference is eventually demonstrated, the problem of determining whether the increased acetaldehyde production is related to the cause of alcoholism or just the result of liver damage caused by heavy drinking, would still remain.

The levels of acetaldehyde determined in blood plasma samples in this study are lower than those determined by Lundquist and Wolthers (1958) and Crow (1975). These workers measured plasma acetaldehyde concentrations

up to 7.5  $\mu\text{M}$  in human subjects who had consumed exactly half the dose of ethanol employed in this study. This difference is probably due to the fact that the acetaldehyde assays employed by Lundquist and Wolthers (1958) and Crow (1975) were being used at their sensitivity limits.

Pulmonary blood acetaldehyde levels, determined by breath acetaldehyde analysis, showed considerable inter-individual variation but for all the normal volunteers, fell within the range of 0.9 - 19  $\mu\text{M}$ , with a mean level of 4.0  $\mu\text{M}$ , when 1.0 g/kg doses of ethanol were being metabolized. The fluctuations in the breath acetaldehyde levels of single subjects, with time, during the metabolism of ethanol, could be explained partly by the inherent variability of the assay method. However, the inter-individual variations were too large to be accounted for entirely in this way. A large inter-individual variation in maximum breath acetaldehyde concentrations after standard ethanol doses in man has also been reported by Fukui (1969). Since in the present study, there appeared to be no relationship between ethanol clearance rate and breath acetaldehyde levels, the inter-individual differences in acetaldehyde levels were probably not due to differences in the rate of acetaldehyde production in the liver and are presumably due to differences in the rate of disposal of acetaldehyde. Such differences may be related to hepatic levels of aldehyde dehydrogenase as it has been demonstrated in rats, that blood acetaldehyde levels (which have been found to reflect hepatic acetaldehyde levels (Eriksson and Sippel, 1977)) are negatively correlated with hepatic aldehyde dehydrogenase levels (Eriksson, 1977; Koivula and Lindros, 1975; Lindros *et al*, 1975; Tottmar and Marchner, 1975; Lindros, 1975; Eriksson, 1973).

The dependence of breath acetaldehyde levels on the dose of ethanol administered to subjects was clearly demonstrated both in this study and that of Freund and O'Hollaren (1965). The work of Freund and O'Hollaren indicated that the breath level of acetaldehyde in humans is dependent on ethanol dose between 0.1 g/kg and 0.8 g/kg, and their results suggested that a further increase in ethanol dose has little effect on breath acetaldehyde levels. These conclusions are supported by the results of Fukui (1969). Eriksson (1977) has also shown that, in rats, there is a positive correlation between hepatic acetaldehyde and ethanol concentrations when hepatic ethanol concentrations are less than 30 mM. Since the oxidation of ethanol in the liver is zero-order throughout the range of blood ethanol concentrations used in these studies (Kalant, 1971), the differences between breath acetaldehyde concentrations developed during the metabolism of different ethanol loads should not be due to differences in the hepatic production of acetaldehyde. Unknown factors affecting

the disposal of acetaldehyde are presumably responsible for the dependence of hepatic acetaldehyde output on the hepatic ethanol concentration.

Since acetaldehyde can be measured in breath, it must be assumed that at least some of the acetaldehyde present in pulmonary blood is free to diffuse through the capillaries surrounding the alveoli and is therefore present in an unbound form. However, the possibility of some acetaldehyde binding occurring in arterial blood, as well as to other tissues, means that estimations of total hepatic acetaldehyde output, based on measurements of 'free' acetaldehyde present in pulmonary blood may be erroneous. If, however, it is assumed that all the acetaldehyde in pulmonary blood is present in an unbound state, and that no free acetaldehyde is present in non-hepatic venous blood, then the concentration of acetaldehyde in the hepatic venous blood of the volunteers involved in this study may be calculated to be no greater than  $95 \mu\text{M}$ , with the mean level being  $20 \mu\text{M}$ . This calculation is based on a five-fold dilution of hepatic venous blood by the time it reaches the lungs. Levels of acetaldehyde in cerebral blood would be expected to be similar to those present in pulmonary blood, i.e. no greater than  $19 \mu\text{M}$  with a mean level of  $4 \mu\text{M}$ . The level of acetaldehyde present in the liver would be expected to be very similar to that present in hepatic venous blood. Forsander et al (1969) have shown this to be true for rats.

The extent of extrahepatic metabolism of acetaldehyde is difficult to estimate from the results of the present studies, since the exact nature of the acetaldehyde measured in peripheral blood is unknown. It would appear, however, that no free acetaldehyde reaches the peripheral venous system in humans and therefore must be either metabolized or bound during its passage from the liver, through the arterial system.

Although most studies of the toxic effects of acetaldehyde have involved the use of acetaldehyde concentrations much higher than the estimated maximum hepatic venous blood levels occurring in this study, some studies have indicated that acetaldehyde may exert toxic effects at levels lower than this. For example, although Cederbaum et al (1974, 1975, 1976) have demonstrated that acetaldehyde concentrations of 0.6 - 32 mM are necessary for inhibition of mitochondrial function in vitro, Ammon et al (1971) have demonstrated inactivation of coenzyme A by acetaldehyde at levels lower than  $100 \mu\text{M}$  in the liver and brain of mice. Acetaldehyde concentrations similar to those estimated in pulmonary blood of volunteers involved in this study, have also been shown to cause the release of catecholamines from the perfused isolated cow adrenal gland (Schneider, 1973). Therefore, it is possible, that the levels of acetaldehyde produced in the human system during the metabolism of moderate doses of ethanol,

may be sufficient to cause some metabolic disturbances. Although metabolic effects of acetaldehyde such as the release of catecholamines may be important in the effects of ethanol on the human system (Truitt and Walsh, 1971), of primary interest in relation to the addictive properties of ethanol is the possibility of an in vivo formation of addictive alkaloids in the brain when acetaldehyde is present. Such compounds can be formed by the direct condensation of acetaldehyde with endogenous biogenic amines or as a result of the alteration of biogenic amine metabolism by acetaldehyde (Rahwan, 1975). The condensation product of acetaldehyde and adrenaline has been demonstrated to have pharmacological activity, is taken up by adrenergic nerve terminals and may act as a false transmitter (Osswald et al, 1975). Tetrahydropapaveroline, a tetrahydroisoquinoline derived from the condensation of dopamine with dopaldehyde, has a structure which closely resembles that of highly addictive, naturally occurring alkaloids such as morphine, and it was this similarity which led Davis and Walsh (1970) to propose that such a compound might form the basis of ethanol addiction. Davis and Walsh (1970) have suggested that tetrahydropapaveroline could be formed in vivo as a result of the inhibition by acetaldehyde of dopamine catabolism, which is mediated by aldehyde dehydrogenase.

Although the formation of biogenic amine derived alkaloids has been demonstrated in vivo in rats and man, the experimental conditions employed have been such that tissue levels of the alkaloid precursors (acetaldehyde, biogenic amines and biogenic aldehydes) have been artificially elevated either by the use of inhibitors of biogenic amine and acetaldehyde catabolism (McIsaac, 1961; Dajani and Saheb, 1973; Collins and Bigdelli, 1975) or by chronic administration of alkaloid precursors such as l-dopa (Turner et al, 1974; Sandler et al, 1973). In a recent study, O'Neill and Rahwan (1977) have failed to demonstrate the formation of salsolinol (the condensation product of dopamine and acetaldehyde) in the brain tissue of ethanol dependent mice. O'Neill and Rahwan made no attempt to alter the levels of alkaloid precursors by artificial means during the metabolism of ethanol and doubt was expressed concerning the possibility of alkaloid formation under the normal physiological conditions existing during the metabolism of ethanol. Mice have been shown by Redmond and Cohen (1972) to develop breath acetaldehyde levels in the same range during ethanol metabolism, as those developed by the human subjects in this study. If alkaloid formation cannot be demonstrated in rats, it is unlikely to occur in humans, since the mean levels of acetaldehyde in hepatic and cerebral blood estimated in this study are approximately one order of magnitude lower than the levels of acetaldehyde measured in the hepatic

and cerebral blood of rats (Eriksson, 1977) when both the rats and humans had similar blood ethanol levels.

The work of Tabakoff et al (1976) has suggested that brain levels of acetaldehyde may be an order of magnitude lower than cerebral blood acetaldehyde concentrations in mice metabolizing ethanol and Sippel and Eriksson (1975) have shown in rats, that no acetaldehyde is detectable in rat brain until cerebral blood acetaldehyde levels reach a level of approximately 200  $\mu\text{M}$ . These results indicate that the brain may be partially protected from concentrations of acetaldehyde in cerebral blood, by a metabolic barrier. This may be the reason for the lack of alkaloid formation in the brain under normal conditions of ethanol metabolism. If this situation applies in humans as well, the level of acetaldehyde present in the brain of the subjects involved in this study would be expected to be less than 2  $\mu\text{M}$ . Although it remains to be proven that the synthesis of potentially addictive alkaloids occurs when acetaldehyde concentrations are as low as this, Lahti and Majchrowicz (1969) have shown that acetaldehyde competitively inhibits the oxidation of 5-hydroxyindole acetaldehyde by rat-brain mitochondrial aldehyde dehydrogenase and since the  $K_i$  for acetaldehyde is 2.6  $\mu\text{M}$ , levels of acetaldehyde lower than 2  $\mu\text{M}$  might be expected to cause an accumulation of the above biogenic aldehyde in the brain. Such an accumulation could possibly result in the formation of 5-hydroxyindole acetaldehyde-derived alkaloids.

Throughout this discussion it has been assumed that any acetaldehyde present in tissues of the mammalian body will have been derived from hepatic ethanol metabolism and therefore extrahepatic-tissue levels of acetaldehyde cannot be higher than the acetaldehyde concentration in the liver. This assumption is based on the fact that in the rat, extrahepatic alcohol dehydrogenase levels are extremely low compared to hepatic levels (Raskin and Sokoloff, 1972). This is true especially for the brain (Raskin and Sokoloff, 1972). Mukherji et al (1975) have shown that the perfused rat brain does not metabolize ethanol, and Tabakoff et al (1976) have shown that the capacity of acetaldehyde oxidation in brain tissue of mice is greater than the rate at which acetaldehyde is delivered to the brain via the blood. If this is the case for humans as well, it would appear likely that the brain is only exposed to circulating acetaldehyde.

In conclusion, it may be stated that from the present study, the human brain is exposed to very low levels of acetaldehyde during the metabolism of moderate doses of ethanol by the liver but these levels may be sufficient to exert some inhibitory effects on pathways of biogenic amine metabolism in the brain. However, the task of defining, in humans, the

levels of acetaldehyde which might reach organs such as the brain is complicated by the apparent existence of acetaldehyde in a bound form in human blood. If binding of acetaldehyde to blood does occur in vivo then it is important to know whether this binding is reversible. If it is, then brain tissue may be exposed to higher levels of acetaldehyde than those calculated on the basis of acetaldehyde appearing in the breath.

It is clear that the methods currently available for the determination of acetaldehyde in blood and breath samples of human subjects may not be capable of determining all the acetaldehyde present in the human system during ethanol metabolism. Therefore, future studies on the significance of acetaldehyde in the human system should include an investigation of the possible in vivo binding of acetaldehyde.

## SECTION 7

THE PRODUCTION OF ACETALDEHYDE BY PERFUSED RAT LIVERS  
METABOLIZING ETHANOL

7-1. INTRODUCTION.

While the studies, already described, on acetaldehyde and ethanol metabolism in humans were proceeding, a rat-liver perfusion system was being set up for studies on hepatic ethanol metabolism. The system was required because, for obvious ethical reasons, the direct in vivo study of hepatic metabolism in humans is impossible.

One advantage of the rat-liver perfusion system is that it permits the study of early acetaldehyde production during the first few minutes of ethanol oxidation, and so makes it possible to test the hypothesis of Deitrich (1976), outlined in the introduction to Section 6.

7-2. METHODS.7-2-1. Experimental animals and operative technique.

Male Sprague-Dawley rats were used, weighing 150 - 250g and fed on a standard laboratory diet with water ad libitum.

The rats were anaesthetized for the operation by intraperitoneal injection of Nembutal<sup>1</sup> (30 mg/ml of H<sub>2</sub>O; 5 mg/100g). A tracheal cannula was inserted, and respiration during the operation was facilitated by means of a mechanical respirator. Cannulation of the portal vein, inferior vena cava and bile duct was carried out as described by Hems et al (1966) and the liver was then isolated from the rat by the method of Miller (1973). Once isolated, the liver was attached to the perfusion system and the first 20 ml of perfusate was discarded to remove residual rat blood remaining in the liver. The mean wet weight of the livers used in the studies was 9.8 g and the weights ranged from 6.7 - 12.0 g.

7-2-2. Perfusion system.

All perfusions were performed using a recirculation system based on that described by Hems et al (1966).

---

1. Obtained from Abbot Laboratories (New Zealand) Ltd., Lower Hutt.

The perfusion medium contained washed bovine erythrocytes (haemoglobin concentration 10 g/100 ml), bovine serum albumin<sup>1</sup> (3g/100ml) and approximately 2,000 units of heparin. These components were suspended in glucose- supplemented Krebs-Henseleit buffer, pH 7.4, having the following composition: NaCl, 117.78 mM; KCl, 4.69 mM; CaCl<sub>2</sub>, 1.00 mM; KH<sub>2</sub>PO<sub>4</sub>, 1.16 mM; MgSO<sub>4</sub>, 1.18 mM; NaHCO<sub>3</sub>, 24.3 mM; Glucose, 9.94 mM. The perfusion medium was equilibrated with O<sub>2</sub>:CO<sub>2</sub> (95:5) at 37°C and had a total volume of 200 ml. The medium pH was maintained at 7.4 with 0.5 M NaHCO<sub>3</sub> during the course of each perfusion by using an automatic titrator.

The rat livers were perfused at a rate of 10 - 12 ml/min and at a pressure of 12 - 15 cm of water.

All livers were perfused for one hour before ethanol was added to the perfusion medium reservoir to produce an initial concentration of 32 mM. The hour-long 'pre-perfusion' was employed to allow the metabolic state of the liver to stabilize after the short anoxic period (<5 min) occurring during surgical isolation when the organ was not being supplied with blood. Control perfusions were performed by omitting the addition of ethanol to the perfusion medium.

All perfusate samples used for analysis of metabolites were taken directly from the vena cava cannula. Bile production was determined during the perfusion period by measuring the volume of bile produced during each hour of perfusion.

### 7-2-3. Analytical methods.

Lactate, pyruvate and ethanol were determined by the methods described by Couchman (1974), in protein-free supernatants obtained by mixing samples of perfusate (2 ml) with one volume of ice-cold 1M PCA.

Since some ethanol was lost from the perfusion medium as a result of evaporation in the oxygenator, ethanol oxidation rates calculated for each liver were corrected by subtracting the mean rate of ethanol loss which occurred when a liver was not incorporated in the perfusion circuit.

Acetaldehyde was determined in protein-free supernatants obtained by mixing 0.2 ml samples of perfusate with 1.8 ml of ice-cold 0.6 M PCA. The semi- or fully automated acetaldehyde assay methods previously described were used and correction curves similar to those obtained for human blood acetaldehyde determinations were employed to correct for acetaldehyde Produced from ethanol during deproteinization of the perfusate samples.

---

1. Fraction V, Obtained from Sigma Chemical Co. St. Louis, Mo., U.S.A.

This was dialyzed against three changes of distilled water before use.

The total volume of perfusion medium removed for metabolite analysis was never greater than 1.3% of its initial volume and the small changes in the volume of the perfusion fluid were taken into account in the calculations of the metabolite contents of the medium.

### 7-3. RESULTS AND DISCUSSION.

#### 7-3-1. Ethanol oxidation rates.

Ethanol was oxidized linearly by the perfused livers at a mean rate of 1.7  $\mu$ moles/min/g wet weight (S.D.= 0.39, n=14). Although this rate is approximately 50% lower than ethanol oxidation rates observed in vivo (Crow et al, 1977; Eriksson and Sippel, 1977), they compared favourably with rates measured by workers using perfused rat livers where no attempt was made to artificially stimulate ethanol oxidation rates (Papenberg, 1971; Lindros et al, 1972; Eriksson, 1973; Lindros, 1975; Thurman et al, 1976).

#### 7-3-2. Perfusate concentrations of lactate and pyruvate.

Figs. 7-1 and 7-2 show the lactate and pyruvate concentrations in the perfusate during the perfusion of rat livers for three hours with and without the addition of ethanol to the perfusion medium. The results show that the predominant effect of ethanol was to cause a lowering of the pyruvate level of the medium. This effect has been noted previously by Forsander (1966) who found that in rat liver slices, ethanol lowers pyruvate levels without significantly altering lactate concentrations. A similar effect was noted in perfused rat liver by Forsander et al (1965) and Papenberg (1971). Because there was no large accumulation of lactate during the perfusions, it was assumed that the oxygen supply to the livers was adequate (Schimassek, 1963).

Fig. 7-3 shows the change in lactate:pyruvate ratio during ethanol metabolism. The lactate:pyruvate ratios measured in control perfusions were found to be relatively stable over the three hour perfusion period and were always very close to the normal in vivo ratio of 11 (Hohorst, 1959).

Ethanol metabolism in perfused livers results in a large increase in the lactate:pyruvate ratio in the perfusion medium, an increase which is characteristic of hepatic ethanol metabolism and has been demonstrated many times. The magnitude of the increase in the lactate:pyruvate ratio while perfused livers were metabolizing ethanol was variable but the mean increase above the control values was very similar to that reported by Bullock et al (1974) for perfused rat livers metabolizing ethanol at an initial concentration of 27 mM.

FIGURE 7-1. PERFUSATE LACTATE LEVELS DURING THE PERFUSION OF RAT LIVERS

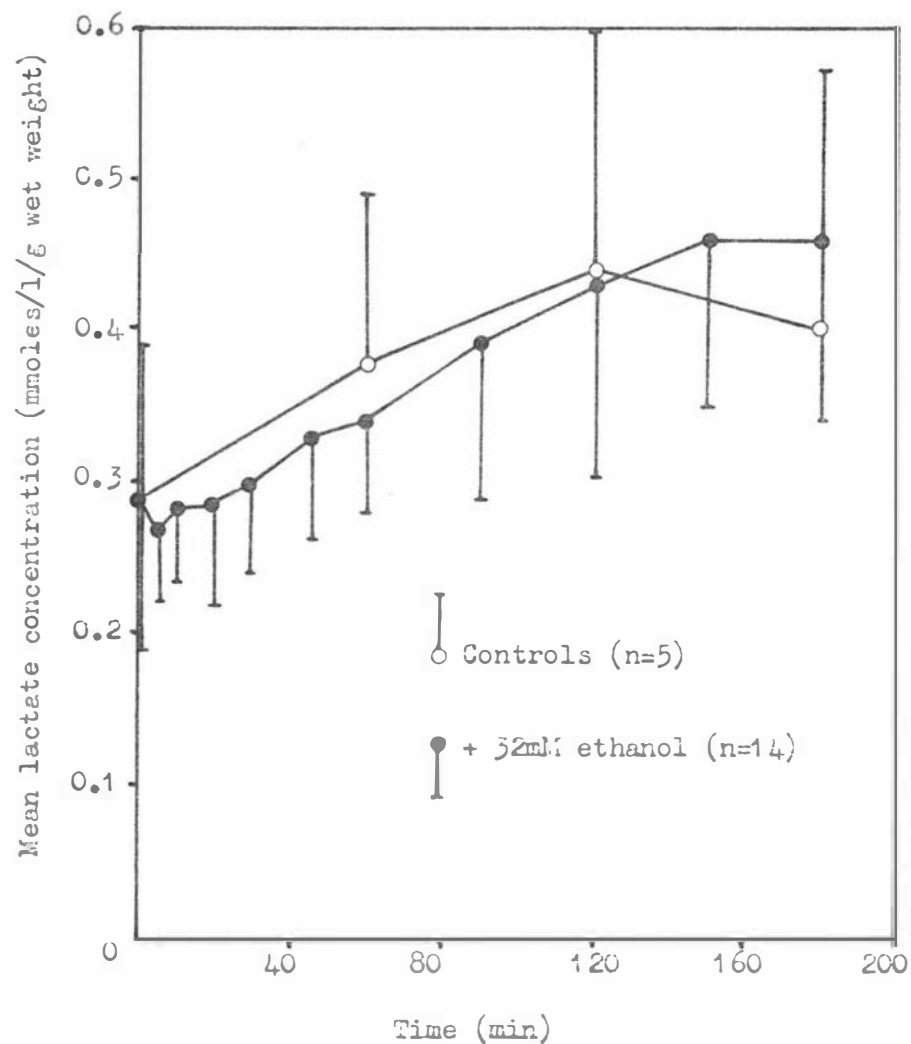
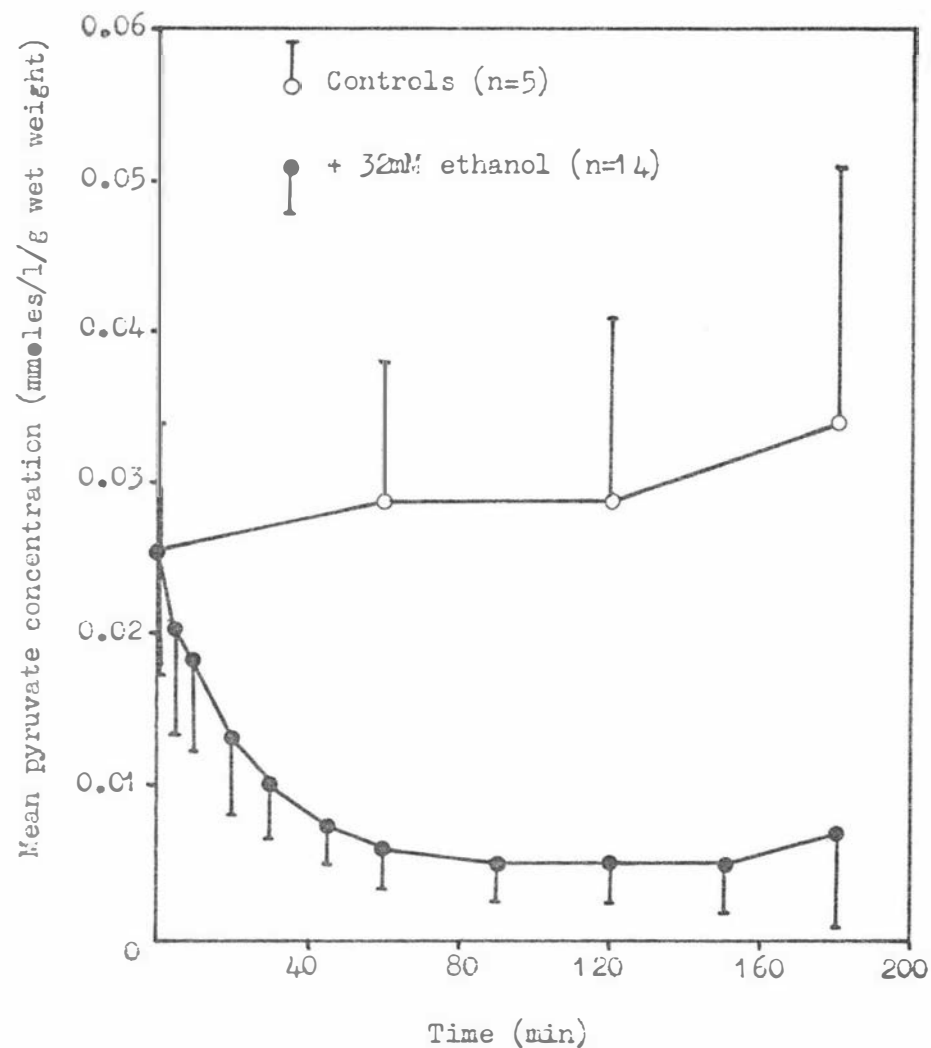
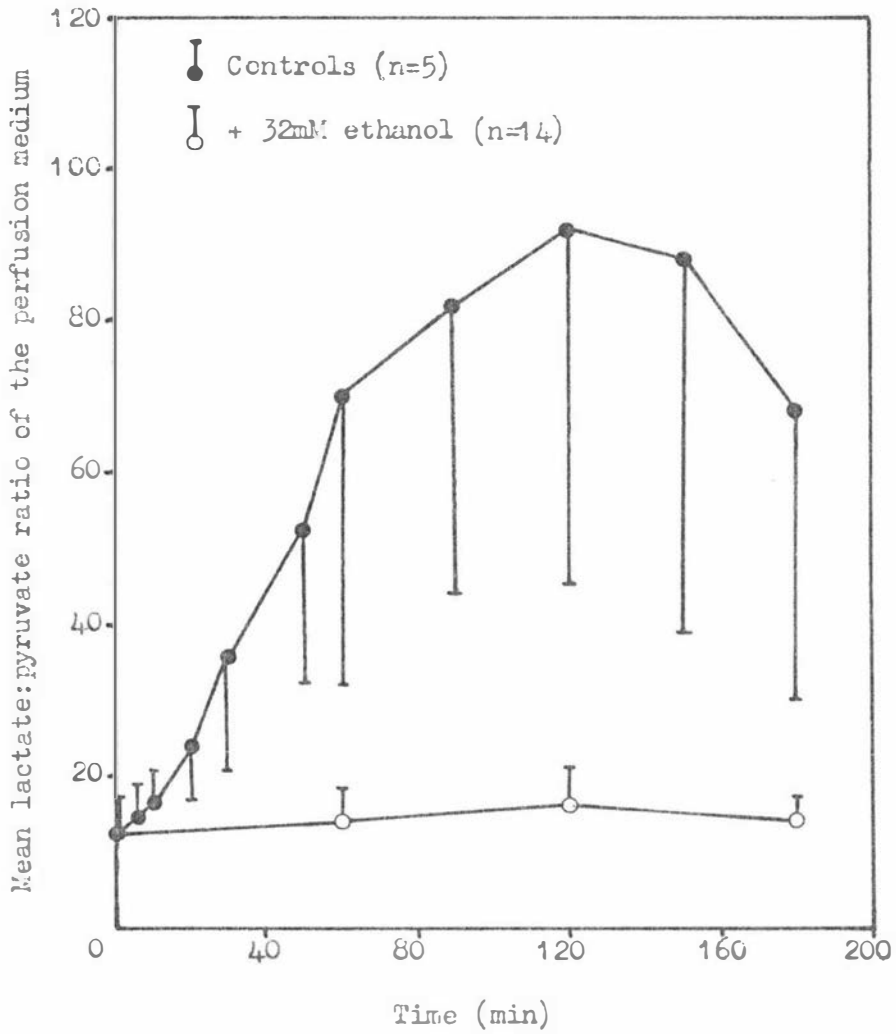

FIGURE 7-2. PERFUSATE PYRUVATE LEVELS DURING THE PERFUSION OF RAT LIVERS



The bar lines represent one standard deviation.

FIGURE 7-3. CHANGE IN THE LACTATE:PYRUVATE RATIO OF THE PERFUSION MEDIUM DURING THE PERFUSION OF RAT LIVERS



The bar lines represent one standard deviation.

### 7-3-3. Bile production.

The production of bile by control livers and those metabolizing ethanol is illustrated in Fig. 7-4. The rates of bile production varied considerably but the mean rates are similar to those which had been measured previously in perfused rat liver systems (Brauer et al, 1951; Graf et al, 1973; Krone et al, 1974; Mørland and Øye, 1974) and the bile production rates measured during the first hour of perfusion (pre-perfusion period) are close to those measured in rats in vivo (Brauer et al, 1951; Graf et al, 1973; Bullock et al, 1974).

The decrease in bile flow which occurred over the four hour perfusion period had been observed by other workers (Krone et al, 1974; Graf et al, 1973) and may result from a reduction in nervous and humoral regulation and/or depletion of various bile precursors (Bartošek et al, 1973).

Although both Mørland and Øye (1974) and Bullock et al (1974) have found that the metabolism of ethanol by perfused rat livers had no significant effect on bile production, the results obtained in this study indicate a difference between the rate of bile production in control livers and those metabolizing ethanol in the third ( $P < 0.05$ , t-test) and fourth ( $P < 0.10$ ) hour of perfusion. This apparent difference is not highly significant, and no conclusion has been drawn concerning the effect of ethanol on bile secretion from this study.

### 7-3-4. Acetaldehyde production by the perfused livers.

The production of acetaldehyde by the livers metabolizing ethanol was variable but characterized in almost all cases by a 'spike' of acetaldehyde appearing in the hepatic venous perfusate at various times after ethanol was added to the perfusion medium. The hepatic acetaldehyde output dropped very rapidly after this initial peak and was often down to very low levels within the first hour of ethanol oxidation. Ethanol was being oxidized at a linear rate throughout the three hour perfusion period and therefore the low levels of acetaldehyde coming from the liver in the second and third hours of perfusion did not result from the absence of ethanol, or its oxidation in the liver. The nature of the production of acetaldehyde from the perfused livers is illustrated by some typical results shown in Fig. 7-5.

No evidence was obtained for the existence of bound acetaldehyde in the perfusate samples. In contrast to the situation with whole human or ox blood, acetaldehyde added to the perfusate decayed very slowly and could be completely recovered using the assay methods described. Acetaldehyde appearing in the perfusate from ethanol metabolism disappeared in perfusate samples at a similar rate to added acetaldehyde and no significant difference was observed between the concentrations of acetaldehyde in whole perfusate

FIGURE 7-4. CHANGES IN BILE FLOW RATES DURING PERFUSION OF RAT LIVERS

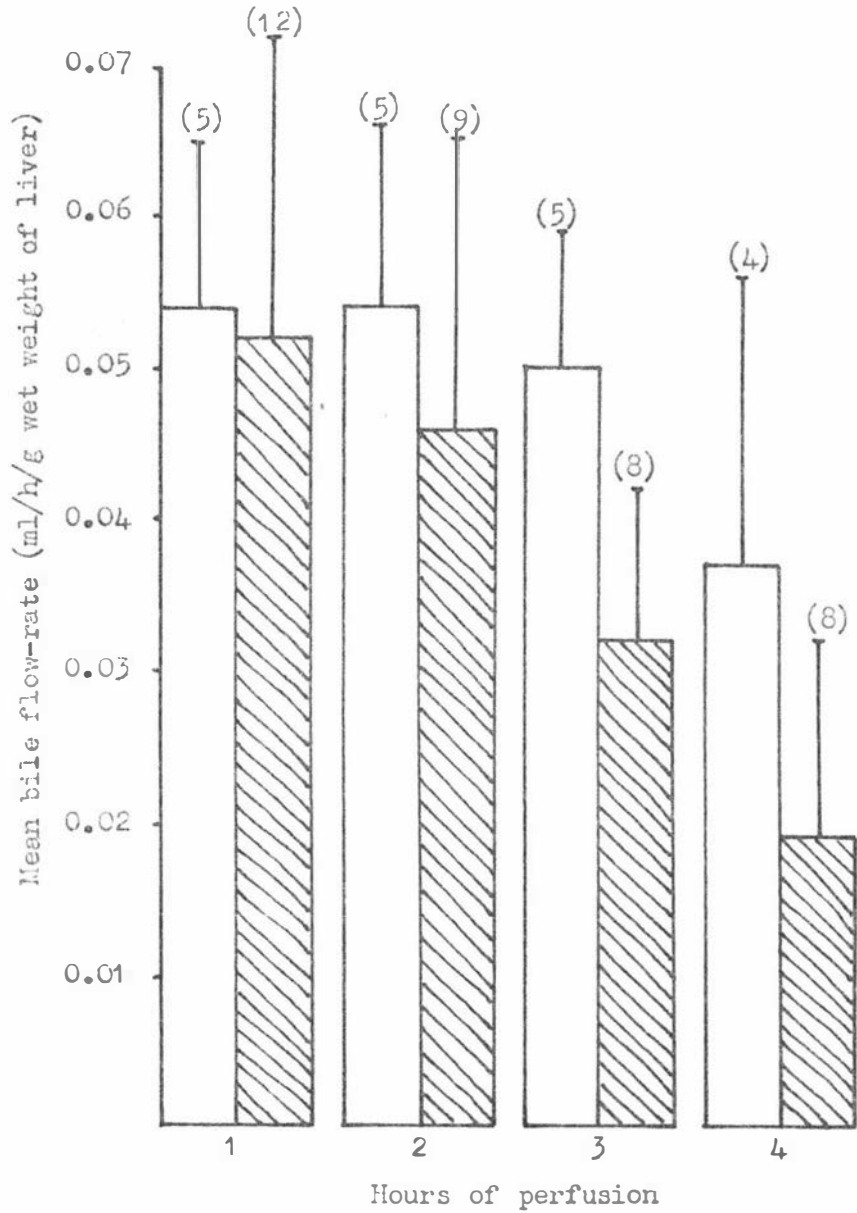

The figures in brackets represent the number of livers for which bile flow was determined and the bar lines represent one standard deviation.

□ Controls

▨ +Ethanol

FIGURE 7-5. THE APPEARANCE OF ACETALDEHYDE IN THE PERFUSATE LEAVING RAT LIVERS METABOLIZING ETHANOL

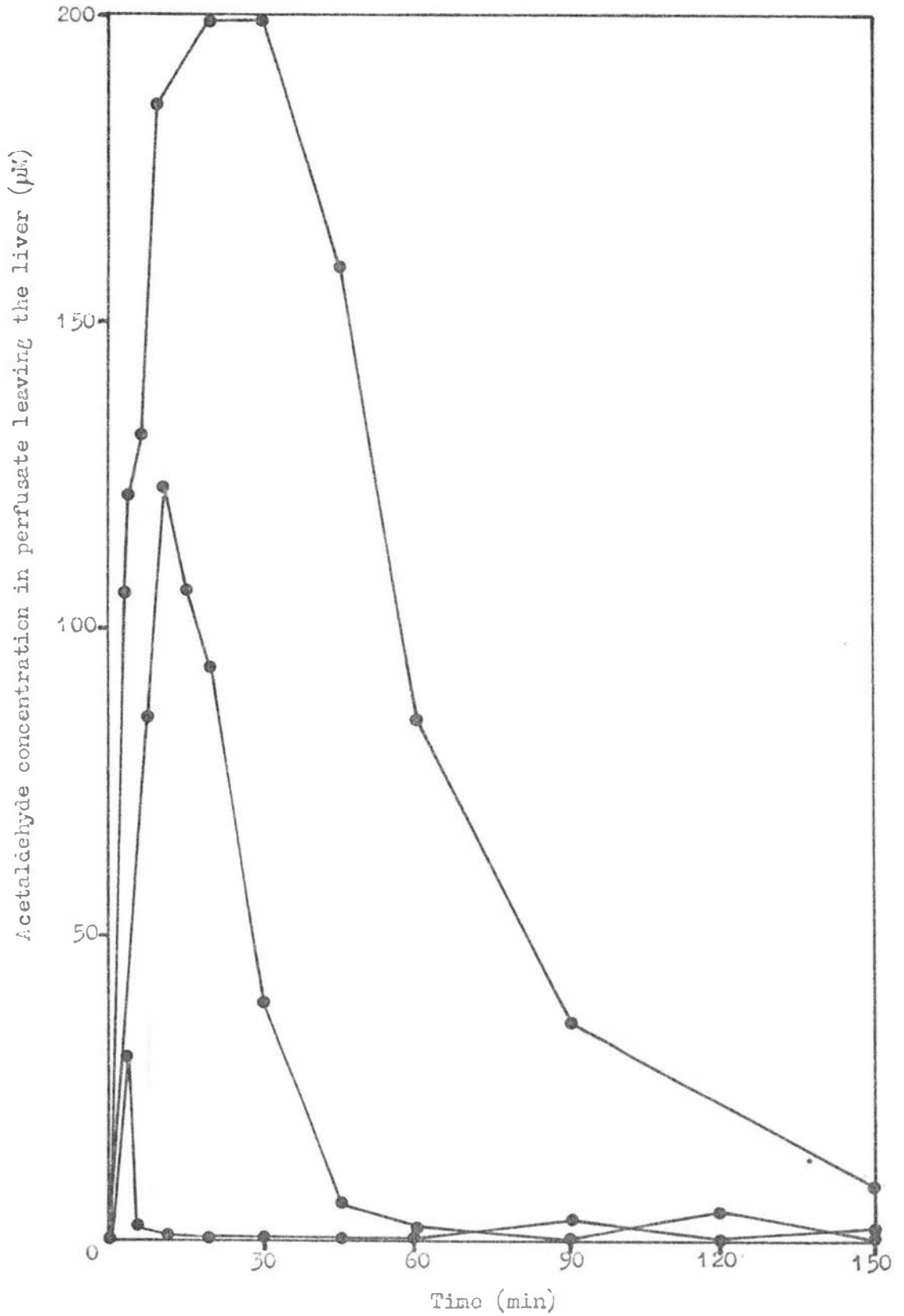

samples and perfusate 'plasma' samples.

Since there is no correlation between ethanol oxidation rates and peak acetaldehyde concentrations (see Fig. 7-6) the variations in hepatic acetaldehyde output do not appear to be related to variations in the steady-state rate of acetaldehyde formation in the liver. A similar lack of correlation existed between the peak acetaldehyde concentrations and rat liver weight and body weight. If the rate of production of acetaldehyde in the liver during the first few minutes of ethanol oxidation is not limited by the NADH reoxidation rate as suggested by Deitrich (1976) then it would be expected to be directly related to the level of alcohol dehydrogenase present in the liver. However, the hepatic output of acetaldehyde is dependent not only on the rate of ethanol oxidation but also on the rate of acetaldehyde oxidation and thus reflects the balance between these two processes. Since this balance may be readily disturbed by small changes in either acetaldehyde production or catabolism in rats (Lindros, 1975) the peaks of acetaldehyde production observed in this study may be caused by an initial rapid rate of ethanol oxidation or by an initial 'lag-phase' during which acetaldehyde oxidation is slightly slower than the rate of acetaldehyde formation.

The large variation in acetaldehyde output by the livers of rats in this study makes the system unsuitable for the study of factors affecting hepatic acetaldehyde output until the reason for this variation is known.

Previous studies of in vitro acetaldehyde production by either isolated rat hepatocytes or perfused livers have given inconsistent results concerning both the magnitude and time course of acetaldehyde release from the whole liver or liver cells. Crow et al (1977) found that negligible levels of acetaldehyde were formed by isolated hepatocytes metabolizing ethanol at an initial level of 8 mM. However, acetaldehyde was not determined until 60 min after ethanol was added to the cell suspensions. Lindros (1975) found that acetaldehyde accumulated to levels of about 500  $\mu$ M in hepatocyte suspensions after a 30 min incubation period, when the ethanol level of the medium was initially 28 mM. Lindros et al (1972) had found that 60% of the acetaldehyde produced in perfused rat livers left the livers unmetabolized, when the livers were metabolizing ethanol at a similar level to that used in this study. It may be calculated from the perfusate flow-rates and ethanol oxidation rates occurring in the present study that no more than 5% of the acetaldehyde formed in the liver appeared in the hepatic venous perfusate. This result is consistent with the results of Eriksson and Sippel (1977) who found that over 95% of the acetaldehyde produced in the rat liver in vivo is oxidized further within

FIGURE 7-6. SCATTER DIAGRAM OF PEAK ACETALDEHYDE CONCENTRATION VERSUS ETHANOL CLEARANCE RATE FOR PERFUSED LIVERS

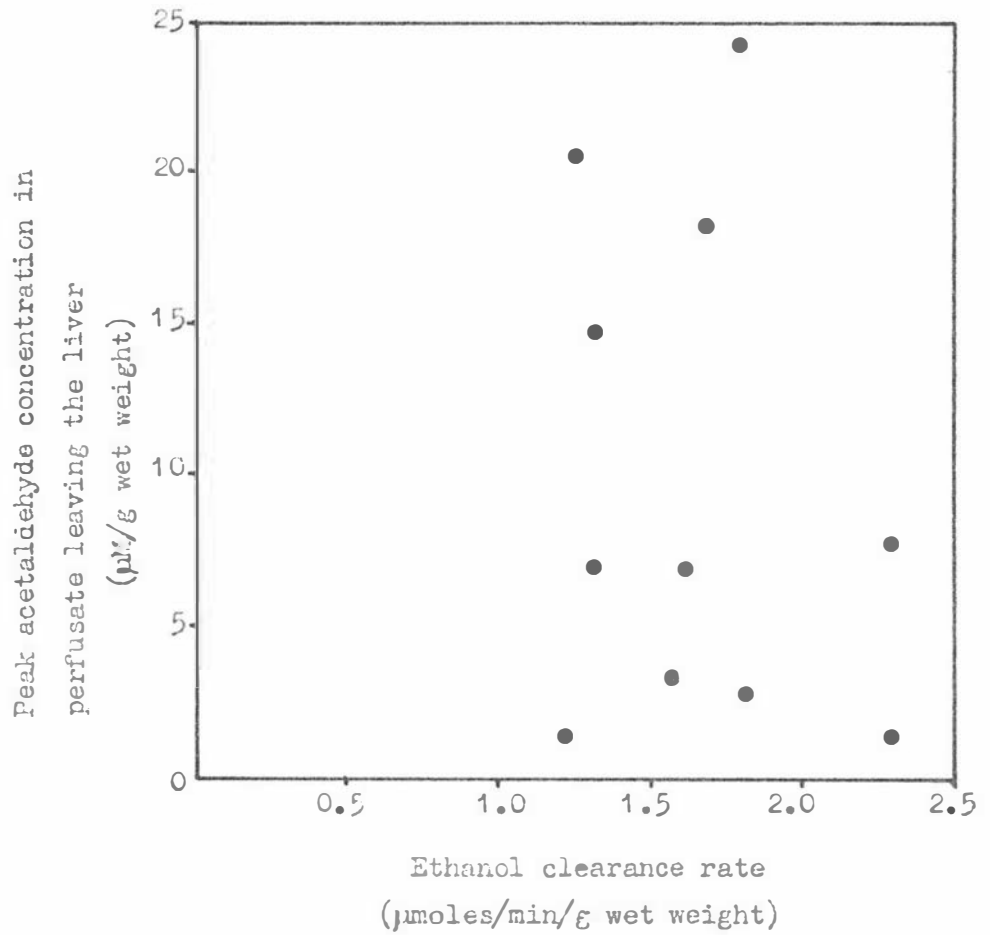

the liver. Using perfused livers, Eriksson (1973) demonstrated that hepatic acetaldehyde output gradually increased during the first hour of perfusion and no sharp peak of acetaldehyde production was observed. The amount of acetaldehyde leaving the liver was as high as 25% of the acetaldehyde produced by metabolism of ethanol in the liver. Eriksson (1973) has also found a large variation in the rates of hepatic acetaldehyde output between livers of different rats.

Few in vivo studies of the variation in hepatic acetaldehyde output throughout the time course of ethanol oxidation in rats have been performed, but Hillbom (1970) and Eriksson and Sippel (1977) have shown that hepatic venous acetaldehyde levels decrease during the oxidation of an acute dose of ethanol and their results do not preclude the possibility of a peak of acetaldehyde occurring in the hepatic venous blood during the first few minutes of ethanol oxidation.

If the results of this study reflect a phenomenon which occurs in vivo then future studies of the toxic potential of acetaldehyde in the mammalian system should include the measurement of acetaldehyde levels directly after ethanol administration in order to determine the maximum hepatic output of acetaldehyde.

## APPENDIX I

PRODUCTION AND STORAGE OF 1-<sup>14</sup>C ACETALDEHYDEI-1. INTRODUCTION.

The high volatility and chemical reactivity of acetaldehyde make it difficult to store very small quantities of this compound unless precautions are taken to eliminate losses due to evaporation, oxidation or polymerization. At the time this study was undertaken, few radiochemical manufacturing companies included <sup>14</sup>C-acetaldehyde in their catalogues and one that did (Commissariat a l'energie atomique, France), stated that up to 30% of the acetaldehyde might be present as paraldehyde. The polymerization of acetaldehyde to paraldehyde occurred even though it was stored under nitrogen.

Since it was known that acetaldehyde reacts readily with semicarbazide to form a non-volatile semicarbazone derivative (Burbridge *et al*, 1950) and the presence of acid favours the formation of acetaldehyde and semicarbazide from this derivative (Conant and Bartlett, 1932), it was thought that small quantities of carrier-free radioactive acetaldehyde could perhaps be stored for long periods as the stable semicarbazone derivative and be regenerated by distillation in the presence of acid, as required.

Ethanol (1-<sup>14</sup>C) was readily available at the time this work was being carried out so it was decided to attempt to produce 1-<sup>14</sup>C acetaldehyde by an enzymic oxidation, trap the acetaldehyde with semicarbazide and regenerate the acetaldehyde from the semicarbazone derivative after various storage times to determine the stability and efficiency of regeneration of acetaldehyde stored in this form.

In carrier-free batches of radioactive compounds, very small amounts of the compounds are usually present. For example, only 200 µg of ethanol was present in the batch of 1-<sup>14</sup>C ethanol used for this work. Enzymic oxidation was considered a simple and appropriate method for converting this quantity of ethanol to acetaldehyde.

I-2. METHODS.I-2-1. Production of acetaldehyde semicarbazone from ethanol.

A reaction mixture designed for the quantitative conversion of up to 200  $\mu\text{g}$  of ethanol to acetaldehyde was prepared, containing the following reagents:-

1 ml of 150 mM pyrophosphate buffer, pH 8.8, containing 150 mM semicarbazide.

0.5 ml of a 14 mM  $\text{NAD}^+$  solution.

0.5 ml of a 1 mg/ml solution of horse liver alcohol dehydrogenase.<sup>1</sup>

The reaction mixture was similar to that used in the alcohol assay method of Lundquist and Wolthers (1958), with  $\text{NAD}^+$  and semicarbazide being present in large excess to ensure the complete conversion of ethanol to acetaldehyde.

After addition of  $^{14}\text{C}$ -labelled ethanol<sup>2</sup> in a total volume of 0.5 ml to the above reagent mixture in amounts between 10 and 40  $\mu\text{g}$ , the reaction was allowed to go to completion. By using unlabelled ethanol and carrying out the reaction in a spectrophotometer cuvette, the time required for the complete reaction could be determined by monitoring light absorbance in the reagent mixture at 340 nm.

After completion of the oxidation, the reagent mixtures were rotary evaporated to dryness at 50°C to remove any residual ethanol, and stored for varying times at -20°C.

#### I-2-2. Regeneration of acetaldehyde from its semicarbazone.

Regeneration of acetaldehyde was carried out by steam distillation in a Markham still using  $\text{H}_2\text{SO}_4$  to hydrolyze the semicarbazone.

The dried reaction mixtures were dissolved in water to make a total volume of about 10 ml and non-radioactive crystalline acetaldehyde semicarbazone was added in amounts from 0.0 to 13.9 mg as carrier. Acid (2M  $\text{H}_2\text{SO}_4$ : 3 ml) was placed in the still followed by the aqueous semicarbazone solution which was injected through a rubber septum placed in the neck of the inlet to the distillation chamber. Steam distillation of the acid/semicarbazone mixture was allowed to proceed for up to 1 min and the distillate was collected in either ice-cold distilled water or 0.1 M phosphate buffer, pH 8.0. The outlet tube of the condenser was always kept beneath the surface of the water or buffer to minimize acetaldehyde losses to the atmosphere. Yields of acetaldehyde were determined by assaying the distillates using either the method of Burbridge *et al* (1950) with the diffusion step in the assay eliminated, or the semiautomated enzymic acetaldehyde assay described in Section 2. Recovery of total counts was

---

1. Obtained from the Sigma Chemical Co.

2. Specific activity = 57 mCi/mnole.

determined by counting aliquots of the semicarbazone solution before distillation as well as aliquots of the distillate and the solution remaining in the still after distillation. Determination of total volatile and non-volatile counts in the distillate at pH 8.0 was performed by counting aliquots of the buffered distillates before and after these distillates were evaporated to dryness and made up again to their original volume with water.

Because the exact concentration of the aqueous 1-<sup>14</sup>C ethanol solution employed for these experiments was not known, no precise determination of chemical recovery of acetaldehyde after distillation could be made when no carrier semicarbazone was used. However, with carrier semicarbazone, the amount of labelled acetaldehyde was negligible compared to the amount of carrier and an accurate estimate of total acetaldehyde recovery could be obtained.

Radioactivity was measured using the scintillation solvent and counting equipment described in Section 4. The error in all counts was  $\pm 2\%$ .

### I-3. RESULTS.

#### I-3-1. Oxidation of ethanol.

In two experiments employing 40  $\mu$ g of unlabelled ethanol, a 91% conversion of the ethanol to acetaldehyde was obtained using the reagent mixture described above and an incubation time of 40 min at room temperature. No further reaction occurred after this time. The acetaldehyde yield was calculated from the absorbance of the solution and the extinction coefficient of NADH, assuming acetaldehyde to be produced in a quantity equal to that of NADH.

#### I-3-2. Regeneration of 1-<sup>14</sup>C acetaldehyde.

Three 1-<sup>14</sup>C acetaldehyde semicarbazone samples formed by enzymic oxidation of ethanol, were regenerated in the presence of different quantities of carrier semicarbazone over a period of 13 months. The results are given in Table I-1.

For the samples regenerated with carrier semicarbazone, the recoveries of volatile counts in the distillate at pH 8.0 are very close to the chemical recoveries of acetaldehyde. This suggests, although it does not prove, that the regenerated acetaldehyde was radiochemically pure. The low level of distilled counts which were non-volatile at pH 8.0 suggested that very little acetate or CO<sub>2</sub> is formed from the acetaldehyde during distillation.

TABLE I-1.

REGENERATION OF 1-<sup>14</sup>C ACETALDEHYDE FROM 1-<sup>14</sup>C ACETALDEHYDE  
SEMICARBAZONE.

Time of storage at -20 C	1 day	5 months	13 months
Weight of acetaldehyde semicarbazone carrier	5.5 mg	2.2 mg	0.0 mg
Acetaldehyde recovered by distillation	4.9 mg	1.9 mg	----
Efficiency of regeneration	89%	86%	----
Total counts in the distillate as a percentage of those distilled	95	87	94
Percentage of counts in the distillate which were volatile at pH 8.0	97	99	98

The sample of 1-<sup>14</sup>C acetaldehyde semicarbazone which was stored for 13 months and regenerated without carrier semicarbazone gave a similar recovery of volatile counts to those samples regenerated with carrier. It would seem, therefore, that the efficiency of the distillation system used is independent of the weight of semicarbazone used within the range of 10 µg - 13.9 mg.

A duplicate sample of the 1-<sup>14</sup>C acetaldehyde which had been stored for 13 months was used for the experiment described in Section 4-2-5. The results of this experiment showed that the volatile counts decayed at the same rate as the acetaldehyde assayed in the diluted blood and the specific activity of the acetaldehyde did not change significantly during the acetaldehyde decay. This is probably the best evidence for the radiochemical purity of the radioactive product obtained by the methods described. Since a storage period of up to 13 months had no significant effect on the purity of the regenerated product compared to storage for one day only, it may be supposed that the semicarbazone derivative of acetaldehyde is a relatively stable compound under the storage conditions used and therefore very useful for the storage of small quantities of radioactive acetaldehyde. The method of production, storage and regeneration of 1-<sup>14</sup>C acetaldehyde described here is very simple with all reagents and equipment readily obtainable and inexpensive. The high yield of acetaldehyde obtained from ethanol and the high recovery of acetaldehyde from the semicarbazone derivative meant that there was only a small loss of acetaldehyde when these methods were used.

## APPENDIX II

ABBREVIATIONS

E.C No.	enzyme commission number
EDTA	ethylene diamine tetra-acetic acid
GC	gas chromatographic
h	hour
I.D.	internal diameter
$K_i$	inhibitor constant
l	litre
MBTH	3-methyl-2-benzothiazolone hydrazone
mCi	millicuries
min	minute
mM	millimoles per litre
n	number of estimations
$NAD^+$	nicotinamide adenine dinucleotide
NADH	reduced nicotinamide adenine dinucleotide
nm	nanometers
nmoles	nanomoles
PCA	perchloric acid
S.D.	standard deviation
sec	second
Tris	2-amino-2-hydroxymethylpropane-1:3-diol
$\mu$ l	microlitre
$\mu$ M	micromoles per litre
v/v	by volume
w/v	weight/volume

REFERENCES

- Ammon, H.P.T., Estler, C.J. and Heim, F. (1971). Effect of alcohol and acetaldehyde on Coenzyme A. In Biological Aspects of Alcohol, Advances in Mental Science III, edited by Roach, M.K., McIsaac, W.M. and Creaven, P.J. University of Texas Press, Austin. pp 185 - 211.
- Barker, S.B. (1941). Acetaldehyde in mammalian red blood cells. J. Biol. Chem. 137, 783 - 784.
- Bartošek, I., Guaitani, A. and Garattini, S. (1975). Prolonged perfusion of isolated rat liver. In Isolated Liver Perfusion and its Applications, edited by Bartošek, I., Guaitani, A. and Miller, L.L. Raven Press, New York. pp 63 - 72.
- Beckmann, J. (1976). A simple micromethod for the determination of acetaldehyde in blood. Naunyn - Schmiedebergs Arch. Pharm. 293, R69.
- Bernt, E. and Bergmeyer, H.U. (1974). Acetaldehyde, Determination with alcohol dehydrogenase from yeast. In Methods of Enzymatic Analysis, Vol. III, edited by Bergmeyer, H.U. Academic Press, New York and London. pp 1506 - 1509.
- Brauer, R.W., Pessotti, R.L. and Pizzolato, P. (1951). Isolated rat liver preparation. Bile production and other basic properties. Proc. Soc. Exp. Biol. Med. 78, 174 - 181.
- Bullock, G., Eakins, M.N., Sawyer, B.C. and Slater, T.F. (1974). Studies on bile secretion with the aid of the isolated perfused rat liver I. Inhibitory action of sporidesmin and icterogenin. Proc. R. Soc Lond. B. 186, 333 - 356.
- Burbridge, T.N., Hine, C.H. and Schick, A.F. (1950). A simple spectrophotometric method for the determination of acetaldehyde in blood. J. Lab. Clin. Med. 35, 983 - 987.

- Cederbaum, A.I., Lieber, C.S. and Rubin, E. (1974). The effect of acetaldehyde on mitochondrial function. Arch. Biochem. Biophys. 161, 26 - 39.
- Cederbaum, A.I., Lieber, C.S. and Rubin, E. (1975). Effect of acetaldehyde on fatty acid oxidation and ketogenesis by hepatic mitochondria. Arch. Biochem. Biophys. 169, 29 - 41.
- Cederbaum, A.I., Lieber, C.S. and Rubin, E. (1976). Effect of chronic ethanol consumption and acetaldehyde on partial reactions of oxidative phosphorylation and CO<sub>2</sub> production from citric acid cycle intermediates. Arch. Biochem. Biophys. 176, 525 - 538.
- Cohen, G. and MacNamee, D. (1976). On the absence of 'endogenous acetaldehyde' in rat and mouse blood. Res. Comm. Chem. Path. Pharm. 14, 489 - 495.
- Collins, M.A. and Bigdeli, M.G. (1975). Tetrahydroisoquinolines in vivo I. Rat brain formation of salsolinol, a condensation product of dopamine and acetaldehyde under certain conditions during ethanol intoxication. Life Sci. 16, 585 - 602.
- Collins, M.A., Custod, J.T., Rubenstein, J.A. and Tabakoff, B. (1976). Studies on the effects of pyrogallol and the structurally related DOPA decarboxylase inhibitor R04-4602 on acetaldehyde metabolism. Ann. N.Y. Acad. Sci. 273, 227 - 233.
- Conant, J.B. and Bartlett, P.D. (1932). A qualitative study of semi-carbazone formation. J. Am. Chem. Soc. 54, 2881 - 2899.
- Couchman, K.G. (1974). Ethanol metabolism in humans. M.Sc. Thesis, Massey University.
- Crow, K.E. (1975). Acetaldehyde metabolism in mammals. Ph.D. Thesis, Massey University.
- Crow, K.E., Cornell, N.W. and Veech, R.L. (1977). The rate of ethanol metabolism in isolated rat hepatocytes. Alcoholism, clinical and experimental research. 1, 43 - 47.

- Crow, K.E., Kitson, T.M., MacGibbon, A.K.H., and Batt, R.D. (1974). Intracellular localisation and properties of aldehyde dehydrogenases from sheep liver. *Biochem. Biophys. Acta.* 350, 121 - 128.
- Dajani, R.M. and Saheb, S.E. (1973). A further insight into the metabolism of certain  $\beta$ -carbolines. *Ann. N.Y. Acad. Sci.* 215, 120 - 123.
- Davis, V.E. and Walsh, M.J. (1970). Alcohol, amines and alkaloids: a possible biochemical basis for alcohol addiction. *Science* 167, 1005 - 1007.
- Deitrich, R.A. (1966). Tissue and subcellular distribution of mammalian aldehyde-oxidizing capacity. *Biochem. Pharmacol.* 15, 1911 - 1922.
- Deitrich, R.A. (1976). Biochemical aspects of alcoholism. *Psychoneuroendocrinology* 1, 325 - 346.
- Deitrich, R.A. and Erwin, V.G. (1975). Involvement of biogenic amine metabolism in ethanol addiction. *Fed. Proc.* 34, 1962 - 1968.
- Duncombe, R.E. and Shaw, W.H.C. (1966). Continuous separation and automatic determination of volatile aldehydes and ketones. In Automation in Analytical Chemistry, Vol. II, edited by Kawaran, E., Jérôme, H. and Stamm, G. Mediad Inc. White Plains, N.Y. pp 15 - 18.
- Duritz, G. and Truitt, E.B. (1964). A rapid method for the simultaneous determination of acetaldehyde and ethanol in blood using gas chromatography. *Quart. J. Stud. Alc.* 25, 498 - 510.
- Eriksson, C.J.P. (1973). Ethanol and acetaldehyde metabolism in rat strains genetically selected for their ethanol preference. *Biochem. Pharm.* 22, 2283 - 2292.
- Eriksson, C.J.P. (1977). The distribution and metabolism of acetaldehyde in rats during ethanol oxidation-II. Regulation of the hepatic acetaldehyde level. *Biochem. Pharm.* 26, 249 - 252.

- Eriksson, C.J.P. and Sippel, H.W. (1977). The distribution and metabolism of acetaldehyde in rats during ethanol oxidation-I. The distribution of acetaldehyde in liver, brain, blood and breath. *Biochem. Pharm.* 26, 241 - 247.
- Eriksson, C.J.P., Sippel, H.W. and Forsander, O.A. (1975). Factors influencing the determination of acetaldehyde in biological samples by head-space gas chromatography. In The Role of Acetaldehyde in the Actions of Ethanol, edited by Lindros, K.O. and Eriksson, C.J.P. Kauppakirjapaino, Helsinki. pp 9 - 18.
- Eriksson, C.J.P., Sippel, H.W. and Forsander, O.A. (1977). The occurrence of acetaldehyde binding in rat blood but not in human blood. *FEBS Lett.* 75, 205 - 208.
- Forsander, O.A. (1966). Influence of the metabolism of ethanol on the lactate:pyruvate ratio of rat-liver slices. *Biochem. J.* 98, 244 - 247.
- Forsander, O.A., Hillbom, M.E. and Lindros, K.O. (1969). Influence of thyroid function on the acetaldehyde level of blood and liver of intact rats during ethanol metabolism. *Acta Pharm. et Tox.* 27, 410 - 416.
- Forsander, O.A., Riih , N., Salasporo, M. and M enp  , P. (1965). Influence of ethanol on the liver metabolism of fed and starved rats. *Biochem. J.* 94, 259 - 265.
- Forsander, O.A. and Sekki, A. (1974). Acetaldehyde and ethanol in the breath of rats after alcohol administration. *Med. Biol.* 52, 276 - 280.
- Fraenkel-Conrat, H. and Olcott, H.S. (1946). Reaction of formaldehyde with proteins-II. Participation of the guanidyl groups and evidence of cross-linking. *J. Amer. Chem. Soc.* 68, 34 - 37.
- Freund, G. and O'Hollaren, P. (1965). Acetaldehyde concentrations in alveolar air following a standard dose of ethanol in man. *J. Lipid Res.* 6, 471 - 477.

- Freundt, K.J. (1968). Turnover of ethanol metabolites in the rabbit and dog. *Arch. Pharmak. Exp. Path.* 260, 114 - 115.
- Freundt, K.J. (1970). Verteilung und stoffwechsel von acetaldehyd im blut. *Beitr. Gerichtl. Med.* 27, 368 - 372.
- Freundt, K.J. (1975). Zum verhalten des alcoholmetaboliten acetaldehyd im Blut. *Blutalkohol.* 12, 389 - 392.
- Fukui, Y. (1969). Gas chromatographic determination of acetaldehyde in the expired air after ingestion of alcohol. *Jap. J. Leg. Med.* 23, 24 - 40.
- Gaines, K.C., Salhany, J.M., Tuma, D.J. and Sorrell, M.F. (1977). Reaction of acetaldehyde with human erythrocyte membrane proteins. *FEBS Lett.* 75, 115 - 119.
- Graf, J., Kaschnitz, R. and Peterlik, H. (1973). Improvement of isolated liver perfusion techniques through use of an 'artificial kidney': Metabolic characteristics as functional criteria. In Isolated Liver Perfusion and its Applications, edited by Bartošek, I., Guaitani, A. and Miller, L.L. Raven Press, N.Y. pp 73 - 78.
- Green, H.D. (1950) Cited in Principles of Human Physiology 13th edition, edited by Davson, H. and Eggleton, M.G. Whitefriars Press Ltd, London and Tonbridge. p 224.
- Harger, R.N., Forney, R.B. and Barnes, H.B. (1950b). Estimation of the level of blood alcohol from analysis of breath. *J. Lab. Clin. Med.* 36, 306 - 318.
- Harger, R.N., Raney, B.B., Bridwell, E.G. and Kitchel, M.K. (1950a). The partition ratio of alcohol between air and water, urine and blood; estimations and identification of alcohol in these liquids from analysis of air equilibrated with them. *J. biol. Chem.* 183, 197 - 213.
- Hasumara, Y., Teschke, R. and Lieber, C.S. (1975). Acetaldehyde oxidation by hepatic mitochondria: decrease after chronic ethanol consumption. *Science* 189, 727 - 728.

- Hauser, T.R. and Cummins, R.L. (1964). Increasing sensitivity of 3-methyl-2-benzothiazolone hydrazone test for analysis of aliphatic aldehydes in air. *Anal. Chem.* 36, 679 - 681.
- Hems, R., Ross, B.D., Berry, M.N. and Krebs, H.A. (1966). Gluconeogenesis in the perfused rat liver. *Biochem. J.* 101, 284 - 292.
- Hendtlass, J. (1973). Ethanol and acetaldehyde metabolism in sheep. Ph.D. Thesis, Massey University.
- Hillbom, M.E. (1970). Influence of sorbitol on the rate of ethanol oxidation and on acetaldehyde accumulation in hypo-, hyper- and euthyroid rats. *Life Sci.* 9, 841 - 846.
- Hohorst, H.J., Kreutz, F.H. and Bücher, T. (1959). Über metabolitgehalte und metabolit-konzentrationen in der leber der ratte. *Biochem. Z.* 332, 18 - 46.
- Kalant, H. (1971). Absorption, diffusion, distribution and elimination of ethanol: effects on biological membranes. In The Biology of Alcoholism Vol I: Biochemistry, edited by Kissin, B. and Begleiter, H. Plenum Press, N.Y. and London. pp 1 - 62.
- Kesäniemi, Y.A. (1974). Ethanol and acetaldehyde in the milk and peripheral blood of lactating women after ethanol administration. *J. Obstet. Gynecol.* 31, 84 - 86.
- Kesäniemi, Y.A. and Sippel, H.W. (1975). Placental and foetal metabolism of acetaldehyde in the rat-I. Contents of ethanol and acetaldehyde in placenta and foetus of the pregnant rat during ethanol oxidation. *Acta Pharm. et Tox.* 37, 43 - 48.
- Kiessling, K.H. (1962a). The effect of acetaldehyde on rat brain mitochondria and its occurrence in brain after alcohol injection. *Exp. Cell Res.* 26, 432 - 434.
- Kiessling, K.H. (1962b). The occurrence of acetaldehyde in various parts of rat brain after alcohol injection and its effect on pyruvate oxidation. *Exp. Cell Res.* 27, 362 - 368.

- Kitson, T.M. (1977). The disulfiram-ethanol reaction. *J. Stud. Alc.* 38, 96 - 113.
- Koivula, T. and Lindros, K.O. (1975). Effects of long-term ethanol treatment on aldehyde and alcohol dehydrogenase activities in rat liver. *Biochem. Pharm.* 24, 1937 - 1942.
- Korsten, M.A., Matsuzaki, S., Feinman, L. and Lieber, C.S. (1975). High blood acetaldehyde levels after ethanol administration. *New Engl. J. Med.* 292, 386 - 389.
- Krebs, H.A. and Perkins, J.R. (1970). The physiological role of liver alcohol dehydrogenase. *Biochem. J.* 118, 635 - 644.
- Krone, W., Huttner, W.B., Kampf, S.C., Rittich, B., Seitz, H.J. and Tarnowski, W. (1974). Long-term perfusion of the isolated rat liver. Maintenance of its functional state by use of a fluorocarbon emulsion. *Biochem. Biophys. Acta.* 372, 55 - 71.
- Lahti, R.A. and Majchrowicz, E. (1969). Acetaldehyde - an inhibitor of the enzymatic oxidation of 5-hydroxyindoleacetaldehyde. *Biochem. Pharm.* 18, 535 - 538.
- Lester, D. (1962). The concentration of apparent endogenous ethanol. *Quart. J. Stud. Alc.* 23, 17 - 25.
- Lieber, C.S. (1975). Alcohol and the liver: Transition from metabolic adaptation to tissue injury and cirrhosis. In Alcoholic Liver Pathology, edited by Khanna, J.M., Israel, Y. and Kalant, H. House of Lind, Canada. pp 171 - 188.
- Lin, D.C. (1975). Brain and blood levels of ethanol and acetaldehyde in strains of mice with different preferences for ethanol. *Res. Comm. Chem. Path. Pharm.* 11, 365 - 371.
- Lindros, K.O. (1975). Regulatory factors in hepatic acetaldehyde metabolism during ethanol oxidation. In The Role of Acetaldehyde in the Actions of Ethanol, edited by Lindros, K.O. and Eriksson, C.J.P. Kauppakirjapaino, Helsinki. pp 67 - 81.

- Lindros, K.O., Koivula, T. and Eriksson, C.J.P. (1975). Acetaldehyde levels during ethanol oxidation: A diet induced change and its relation to liver aldehyde dehydrogenases and redox states. *Life Sci.* 17, 1589 - 1598.
- Lindros, K.O., Vihma, R. and Forsander, O.A. (1972). Utilization and metabolic effects of acetaldehyde and ethanol in the perfused rat liver. *Biochem. J.* 126, 945 - 952.
- Lionetti, F.J., Fortier, N.L. and Jedziniak, J.A. (1964). Acetaldehyde, a product of deoxynucleoside metabolism in human erythrocyte ghosts. *Proc. Soc. Exp. Biol. N.Y.* 116, 1080 - 1082.
- Lüben, V., Post, D. and Grüner, O. (1972). Gaschromatographische untersuchungen zum vorkommen des acetaldehyds in blutproben. *Blutalkohol* 2, 465 - 472.
- Lundquist, F. (1958). Enzymatic determination of acetaldehyde in blood. *Biochem. J.* 68, 172 - 177.
- Lundquist, F. (1974). Acetaldehyde. Determination with aldehyde dehydrogenase. In Methods of Enzymatic Analysis, Vol III, edited by Bergmeyer, H.U. Academic Press, N.Y. and London. pp 1509 - 1513.
- Lundquist, F. and Wolthers, H. (1958). The kinetics of alcohol elimination in man. *Acta Pharm. et Tox.* 14, 265 - 289.
- Machata, G. and Prokop, L. (1971). Alkoholabbau und Acetaldehyd. *Blutalkohol* 34, 231 - 234.
- MacLeod, L.D. (1950). Acetaldehyde in relation to intoxication by ethyl alcohol. *Quart. J. Stud. Alc.* 11, 385 - 390.
- Malorny, G., Reitbrock, N. and Schneider, M. (1965). Die oxydation des formaldehyds zu ameisensäure im blut, ein beitrag zum stoffwechsel des formaldehyds. *Naunyn - Schmiedebergs Arch. Pharm.* 250, 419 - 436.
- Marchner, H. and Tottmar, O. (1976). Influence of diet on the metabolism of acetaldehyde in rats. *Acta Pharm. et Tox.* 38, 58 - 71.

- Matthies, H. (1956). Über eine aldehydoxydase in roten blutkörperchen. Naturwissenschaften 43, 200 - 201.
- Matthies, H. (1957a). Die wirkung von aldehyden auf die methämoglobin-rückbildung in erythrocyten. Biochem. Z. 329, 341 - 345.
- Matthies, H. (1957b). Untersuchungen über eine aldehyde-dehydrogenase in kernlosen erythrocyten. Biochem. Z. 329, 421 - 427.
- Matthies, H. (1958). Vergleichende untersuchungen über die aldehyd-dehydrogenase kernloser erythrocyten. Biochem. Z. 330, 169 - 173.
- McIsaac, W.M. (1961). Formation of 1-methyl-6-methoxy-1,2,3,4,-tetrahydro-2-carboline under physiological conditions. Biochem. Biophys. Acta 52, 607 - 609.
- McLean, J.W. (1975). Acetate metabolism in humans. Dissertation for fulfillment of B.Sc. Hons., Massey University.
- Miller, L.L. (1973). Technique of isolated rat liver perfusion. In Isolated Liver Perfusion and its Applications, edited by Bartošek, I., Guaitani, A. and Miller, L.L. Raven Press, N.Y. pp 11 - 52.
- Mohammed, A., Olcott, H.S. and Fraenkel-Conrat, H. (1949). The reaction of proteins with acetaldehyde. Arch. Biochem. 24, 270 - 280.
- Mørland, J. and Øye, I. (1974). Effect of acute and chronic ethanol treatment on hepatic triglyceride release from the rat perfused liver. Eur. J. Pharm. 27, 238 - 244.
- Mukherji, B., Kashiki, Y., Ohyanagi, H. and Sloviter, H.A. (1975). Metabolism of ethanol and acetaldehyde by the isolated perfused rat brain. J. Neurochem. 24, 841 - 843.
- Nagasawa, H.T., Goon, D.J.W., Constantino, N.V. and Alexander, C.S. (1975). Diversion of ethanol metabolism by sulfhydryl amino acids. D-penicillamine-directed excretion of 2,5,5-trimethyl-D-thiazolidine-4-carboxylic acid in the urine of rats after ethanol administration. Life Sci. 17, 707 - 714.

- Nagasawa, H.T., Goon, D.J.W., Demaster, E.G. and Alexander, C.S. (1977). Lowering of ethanol-derived circulating blood acetaldehyde in rats by D-penicillamine. *Life Sci.* 20, 187 - 194.
- O'Neill, P.J. and Rahwan, R.G. (1977). Absence of formation of brain salsolinol in ethanol-dependent mice. *J. Pharm. Exp. Ther.* 200, 306 - 313.
- Cortiz, A., Griffiths, P.J. and Littleton, J.M. (1974). A comparison of the effects of chronic administration of ethanol and acetaldehyde to mice: evidence for a role of acetaldehyde in ethanol dependence. *J. Pharm. Pharmac.* 26, 249 - 260.
- Osswald, W., Polónia, J. and Polónia, M.A. (1975). Preparation and pharmacological activity of the condensation product of adrenaline with acetaldehyde. *Naunyn - Schmiedebergs Arch. Pharm.* 289, 275 - 290.
- Fapenberg, J. (1971). Ethanol metabolism of the isolated perfused rat liver. 1. Effect of ethanol oxidation on substrate levels. 2. effects of fructose and pyrazole on ethanol oxidation. In Metabolic Changes Induced by Alcohol, edited by Martini, G.A. and Bode, Ch. Springer-Verlag, Berlin, Heidelberg, N.Y. pp 53 - 61.
- Fetttersson, H. and Kiessling, K.H. (1976). Acetaldehyde occurrence in cerebrospinal fluid during ethanol oxidation in rats and its dependence on the blood level and on dietary factors. *Biochem. Pharm.* 26, 237 - 240.
- Rahwan, R.G. (1974). Speculations on the biochemical pharmacology of ethanol. *Life Sci.* 15, 617 - 633.
- Rahwan, R.G. (1975). Toxic effects of ethanol: Possible role of acetaldehyde, tetrahydroisoquinolines, and tetrahydro- $\beta$ -carbolines. *Toxicol. Appl. Pharm.* 34, 3 - 27.
- Raskin, H.H. (1975). Alcoholism or acetaldehydism? *New Engl. J. Med.* 293, 422 - 423.

- Raskin, N.H. and Sokoloff, L. (1972). Enzymes catalysing ethanol metabolism in neural and somatic tissues of the rat. *J. Neurochem.* 19, 273 - 282.
- Redmond, G.P. and Cohen, G. (1972). Sex difference in acetaldehyde exhalation following ethanol administration in C57BL mice. *Nature* 236, 117 - 119.
- Sandler, M., Bonham-Carter, S., Hunter, K.R. and Stern, G.M. (1973). Tetrahydroisoquinoline alkaloids, in vivo metabolites of L-dopa in man. *Nature* 241, 439 - 443.
- Schimassek, H. (1963). Metabolite des Kohlenhydratstoffwechsels der isoliert perfundierten rattenleber. *Biochem. Z.* 336, 460 - 467.
- Schneider, F.H. (1973). Effects of length of exposure to and concentration of acetaldehyde on the release of catecholamines. *Biochem. Pharmacol.* 23, 223 - 229.
- Schormüller, J., Grampp, E. and Belitz, H.D. (1968). Veränderungen von milchproteinen durch einwirkung von carbonylverbindungen I. Mitteilung. Reaktion von casein mit äthanal. *Z. Lebensmittel. Unters. Forsch.* 136, 271 - 278.
- Sheppard, J.R., Albersheim, P. and McClearn, G. (1970). Aldehyde dehydrogenase and ethanol preference in mice. *J. Biol. Chem.* 245, 2876 - 2882.
- Sippel, H.W. (1972). Thiourea, an effective inhibitor of the non-enzymatic ethanol oxidation in biological extracts. *Acta Chem. Scand.* 26, 3398 - 3400.
- Sippel, H.W. (1973). Non-enzymatic ethanol oxidation in biological extracts. *Acta Chem. Scand.* 27, 541 - 550.
- Sippel, H.W. and Eriksson, C.J.P. (1975). The acetaldehyde content in rat brain during ethanol metabolism. In The Role of Acetaldehyde in the Actions of Ethanol, edited by Lindros, K.O. and Eriksson, C.J.P. Kauppakirjapaino, Helsinki. pp 149 - 157.

- Smalldon, K.W. and Brown, G.A. (1973). The stability of ethanol in stored blood. Part II. The mechanism of ethanol oxidation. *Anal. Chim. Acta* 66, 285 - 290.
- Sprince, H., Parker, C.M., Smith, G.C. and Gonzales, L.J. (1975). Protective action of ascorbic acid and sulfur compounds against acetaldehyde toxicity: Implications in alcoholism and smoking. *Agents and Actions* 5, 164 - 173.
- Stotz, E. (1943). A colorimetric determination of acetaldehyde in blood. *J. biol. Chem.* 148, 585 - 591.
- Tabakoff, B., Anderson, R.A. and Ritzmann, R.F. (1976). Brain acetaldehyde after ethanol administration. *Biochem. Pharm.* 25, 1305 - 1309.
- Thurman, R.G., McKenna, W.R. and McCaffrey, T.B. (1976). Pathways responsible for the adaptive increase in ethanol utilization following chronic treatment with ethanol: Inhibitor studies with hemoglobin-free perfused rat liver. *Mol. Pharm.* 12, 156 - 166.
- Tottmar, O. and Marchner, H. (1975). Characteristics of the acetaldehyde oxidation in rat liver, and the effects of antabuse, 4-methylpyrazole and unknown dietary factors on the hepatic output of acetaldehyde. In The Role of Acetaldehyde in the Actions of Ethanol, edited by Lindros, K.O. and Eriksson, C.J.P. Kauppakirjapaino, Helsinki. pp 47 - 66.
- Tottmar, O. and Marchner, H. (1976). Disulfiram as a tool in the studies on the metabolism of acetaldehyde in rats. *Acta Pharm. et Tox.* 38, 366 - 375.
- Truitt, E.B. (1970). Ethanol-induced release of acetaldehyde from blood and its effect on the determination of acetaldehyde. *Quart. J. Stud. Alc.* 31, 1 - 12.
- Truitt, E.B. (1971). Blood acetaldehyde levels after alcohol consumption by alcoholic and non-alcoholic subjects. In Biological Aspects of Alcohol, Advances in Mental Science III, edited by Roach, M.K., McIsaac, W.M. and Creaven, P.J. University of Texas Press. pp 212 - 232.

- Truitt, E.B. and Duritz, G. (1967). The role of acetaldehyde in the actions of ethanol. In Biochemical Factors in Alcoholism, edited by Maickel, R.P. Pergamon Press. Oxford, London, Edinburgh, N.Y. Toronto, etc. pp 61 - 69.
- Truitt, E.B. and Walsh, M.J. (1971). The role of acetaldehyde in the actions of ethanol. In The Biology of Alcoholism, Vol I, Biochemistry, edited by Kissin, B. and Begleiter, H. Plenum Press. N.Y. and London. pp 161 - 195.
- Turner, A.J., Baker, K.M., Algeri, S., Frigerio, A. and Carrattini, S. (1974). Tetrahydropapaveroline: formation in vivo and in vitro in rat brain. *Life Sci.* 14, 2247 - 2257.
- Velluz, L., Amiard, G. and Pesez, M. (1948). Aldehydes and the Doebner-Miller reaction. I. 2-methyl-5-carboxy-7-aminoquinoline. *Bull. Soc. Chim. France.* 1948, 678 - 679.
- Walsh, M.J. (1971). Role of acetaldehyde in the interactions of ethanol with neuroamines. In Biological Aspects of Alcohol, Advances in Mental Science III, edited by Roach, M.K., McIsaac, W.M. and Creaven, P.J. University of Texas Press. pp 233 - 254.
- Wright, B.M., Jones, T.P. and Jones, A.W. (1975). Breath alcohol analysis and the blood:breath ratio. *Med. Sci. Law.* 15, 205 - 210.